



ATLANTIS

8060



1

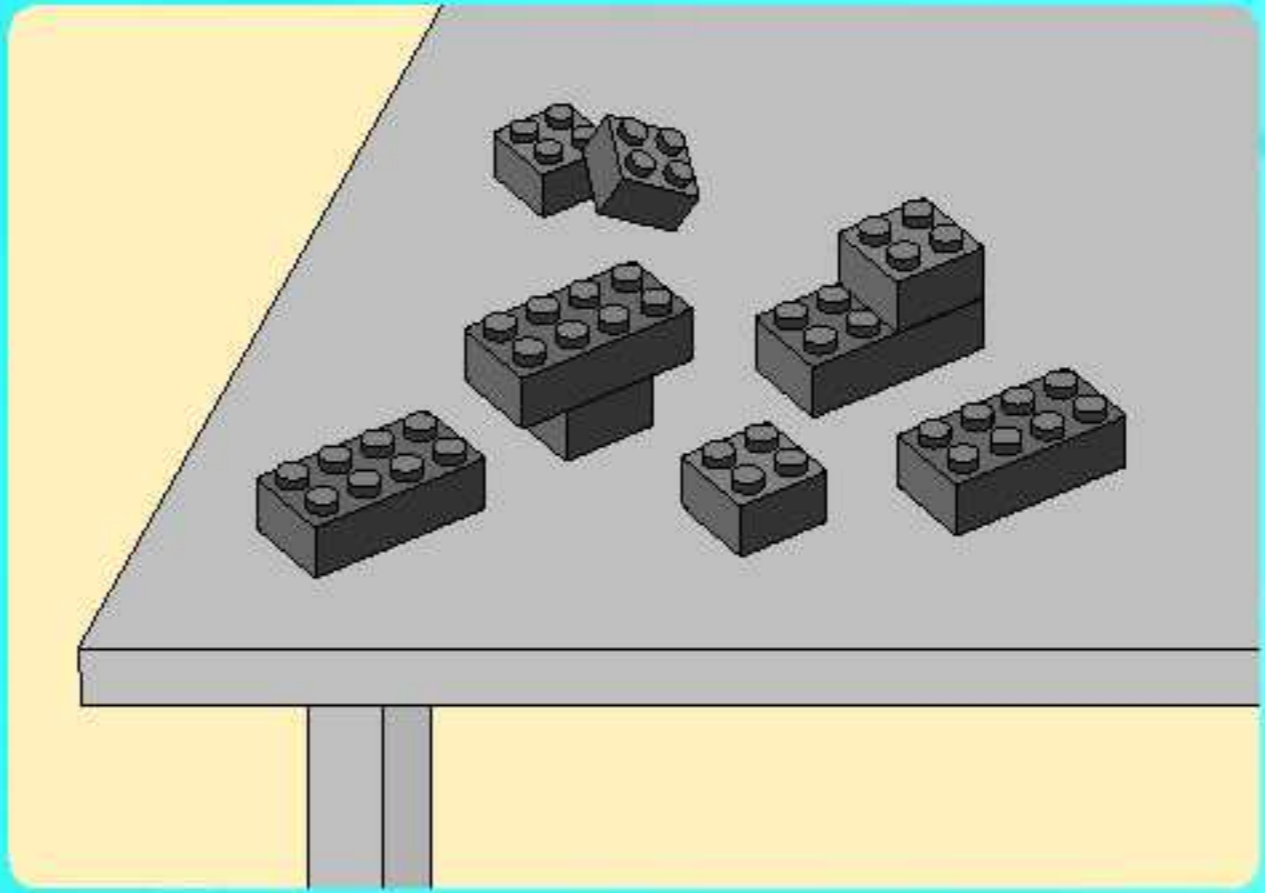
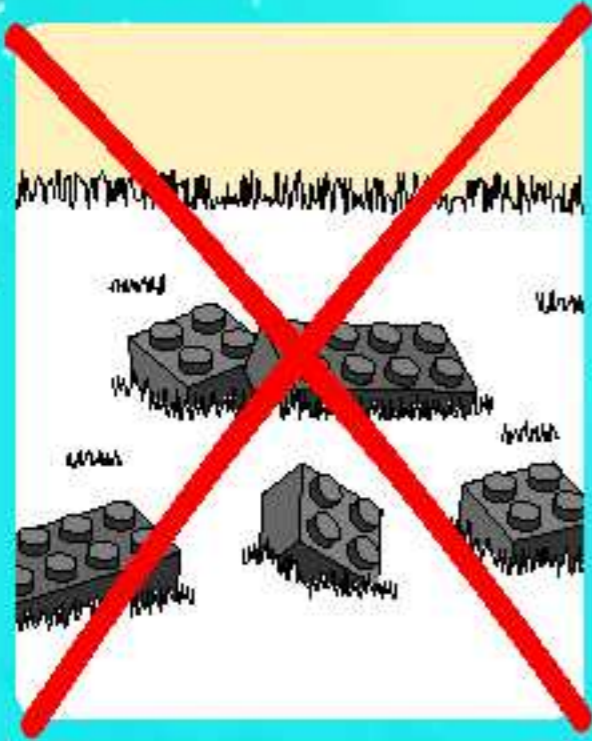

2

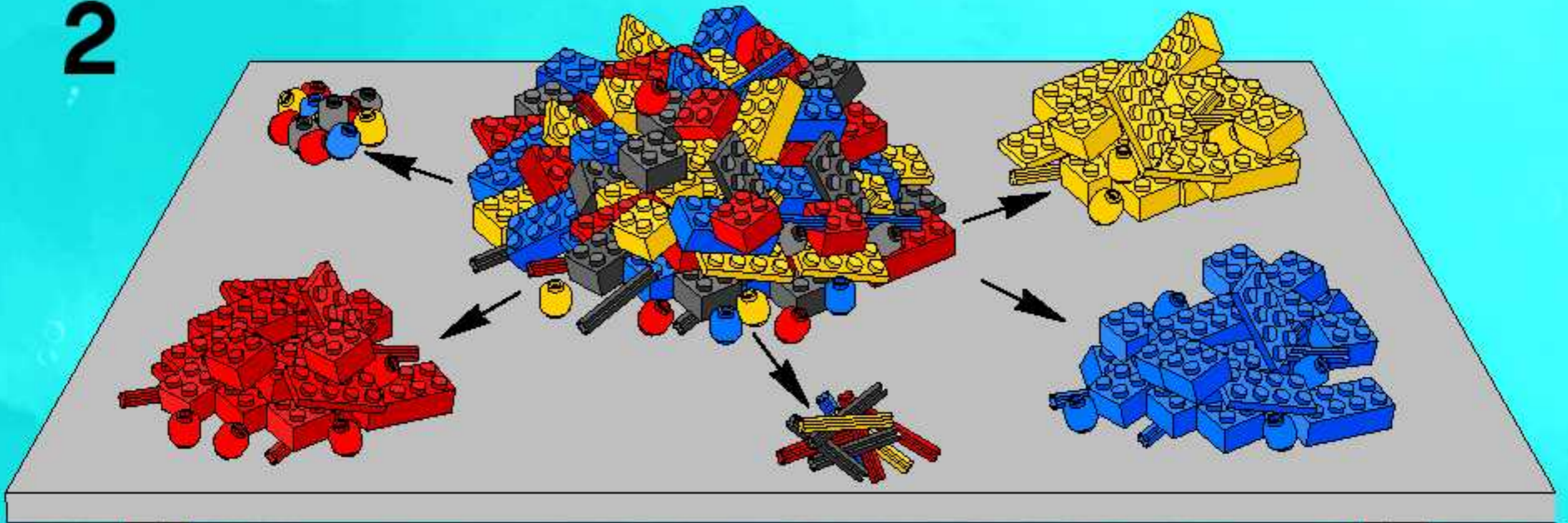

3

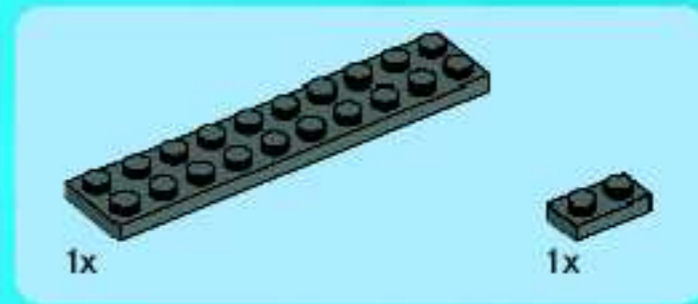
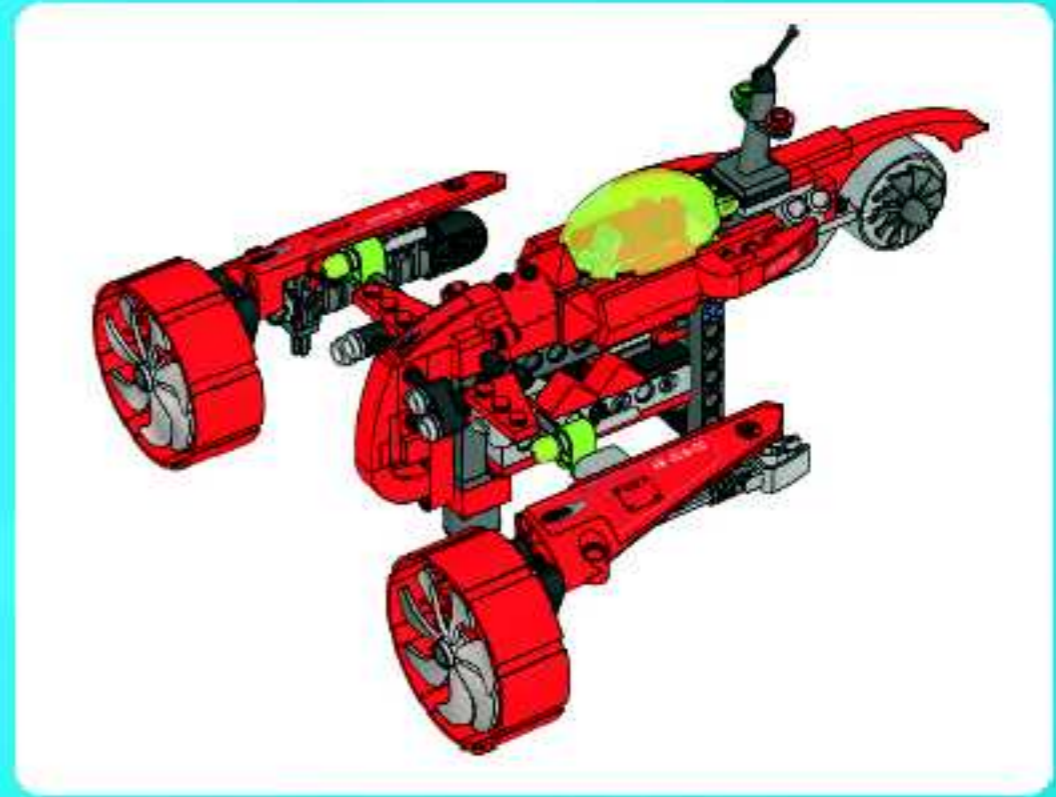
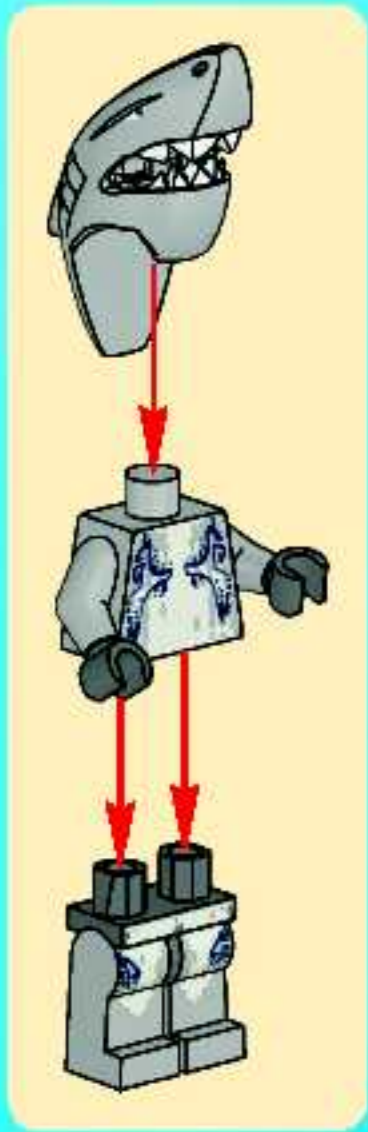

1

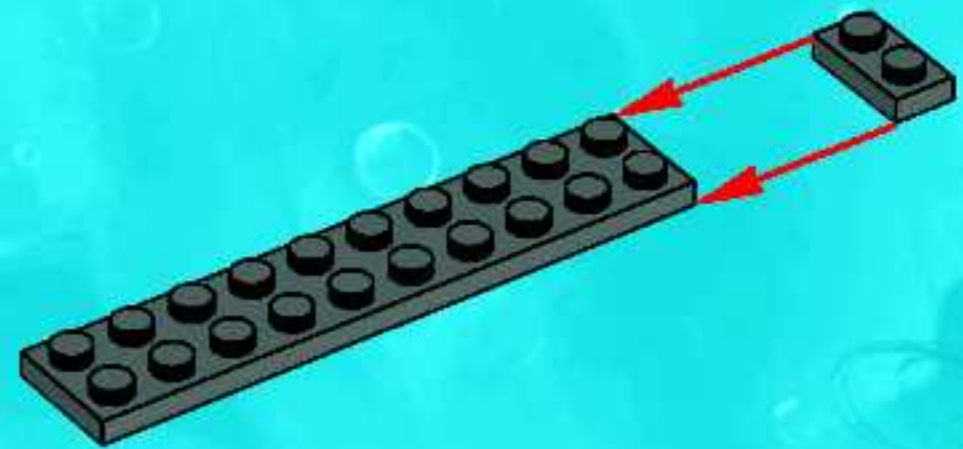

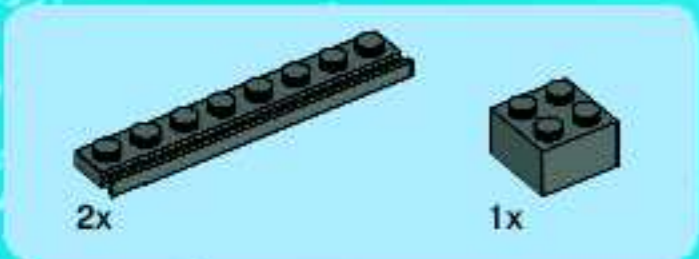

2

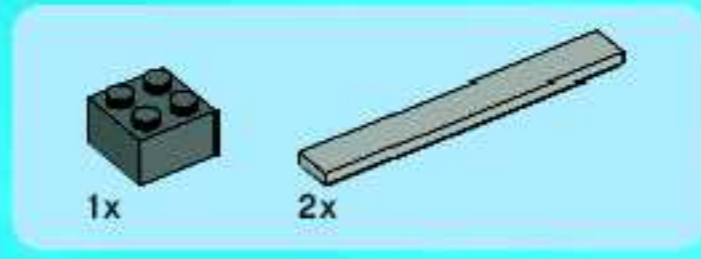
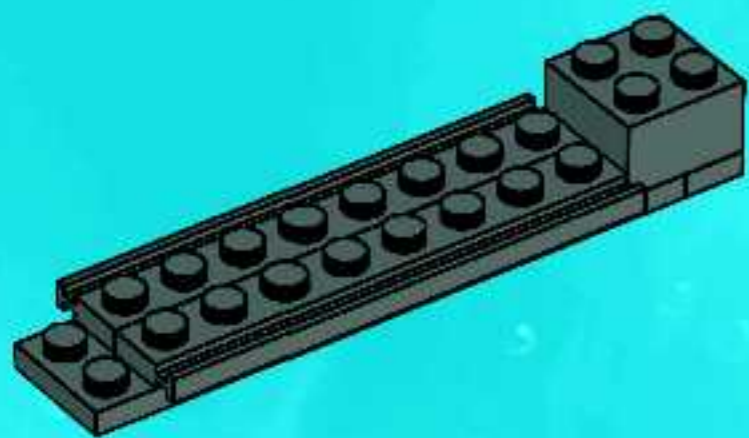

3

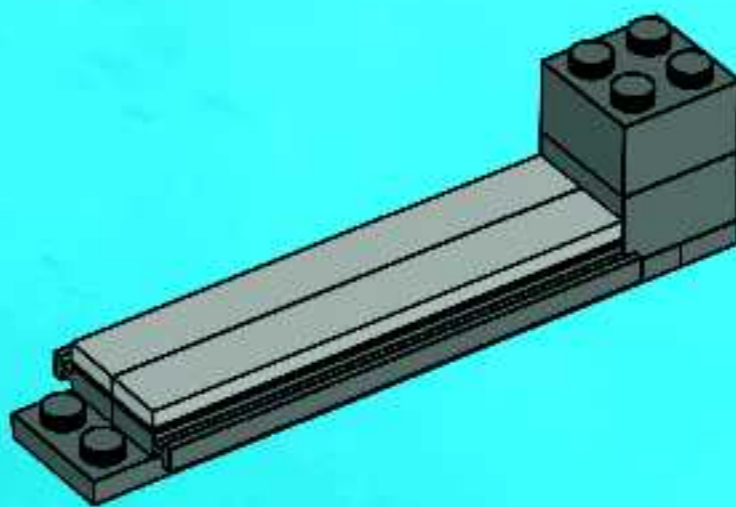



1x



1x

4

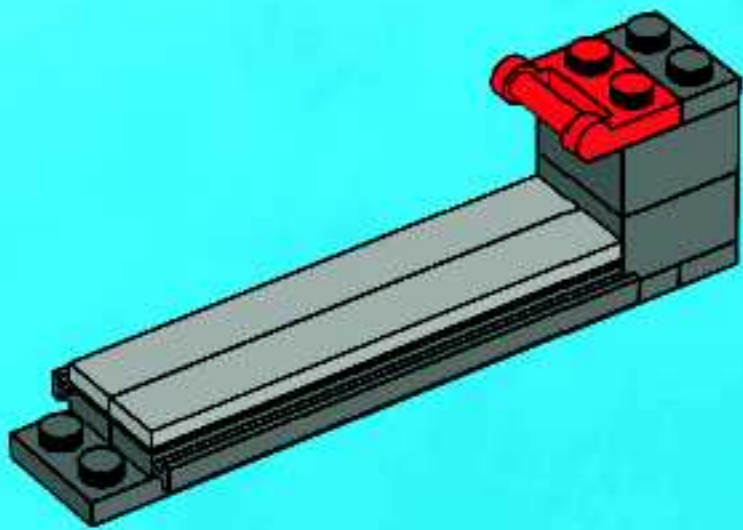

1x

5

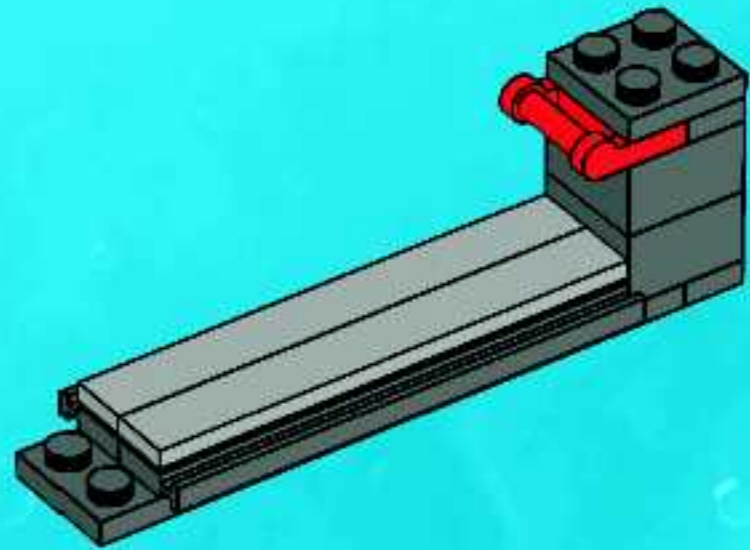

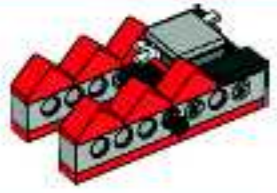

5x

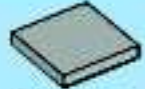

1x



2x



2x



1x



1x

1

1

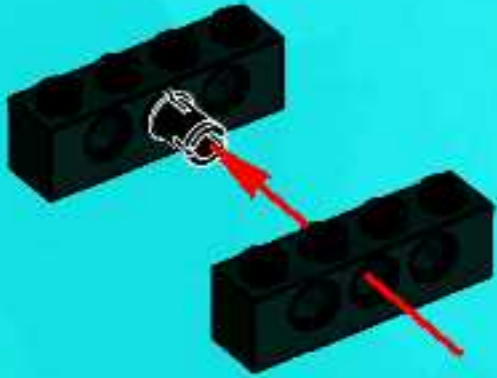

2



3



4



5

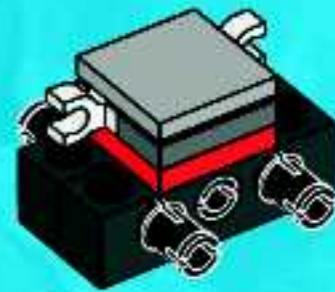

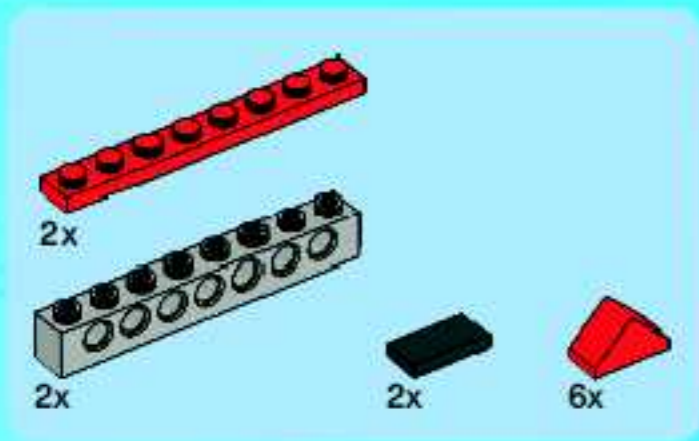

2

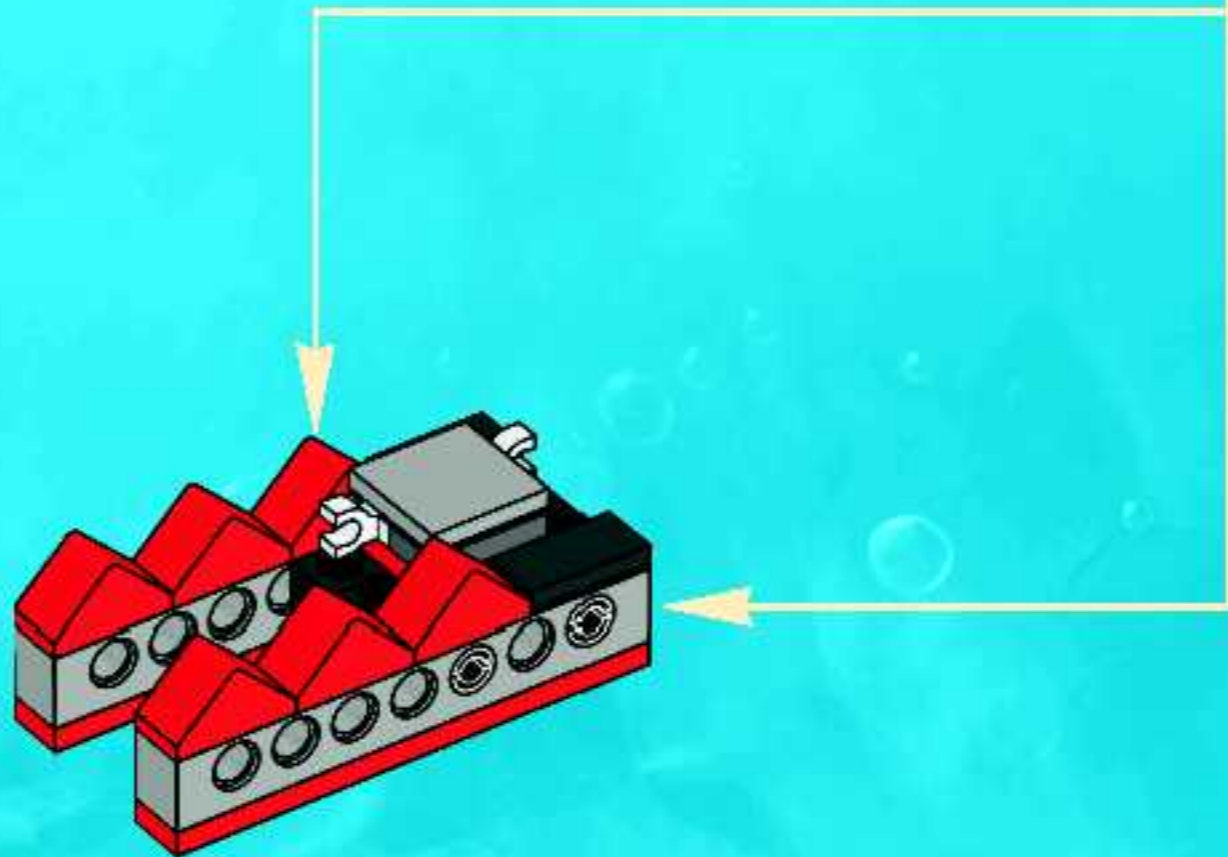
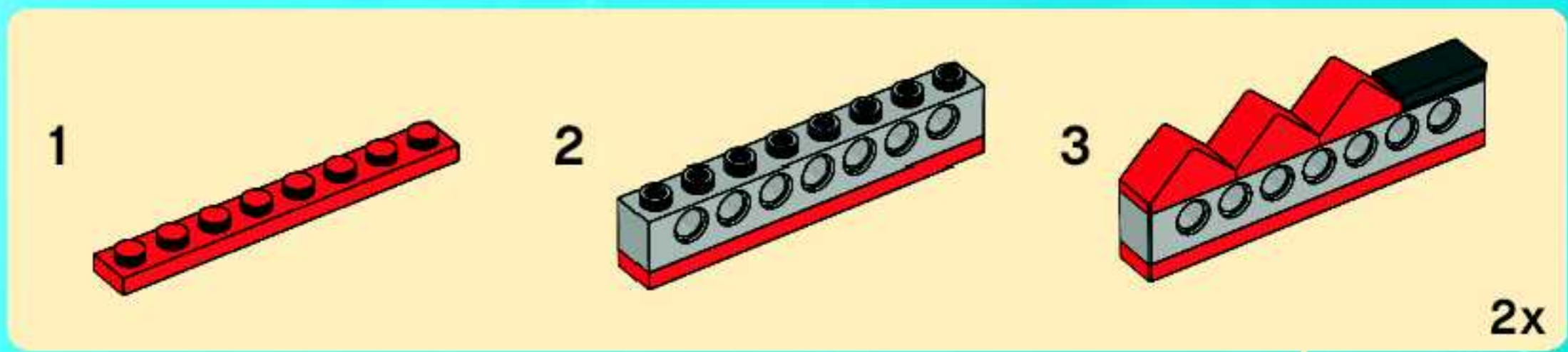



3

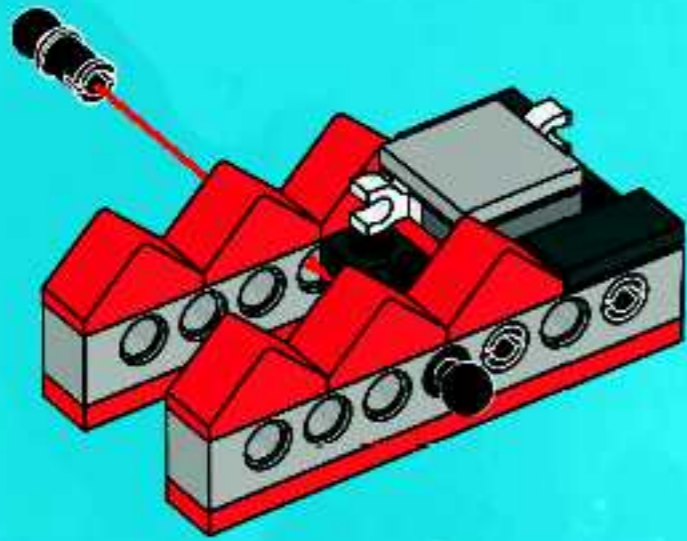

6

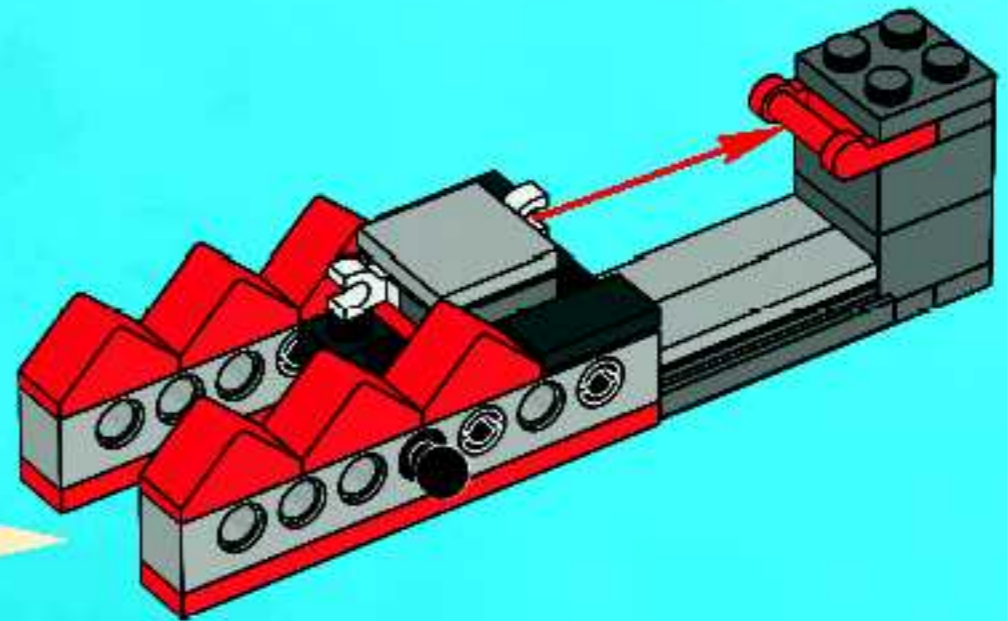



7

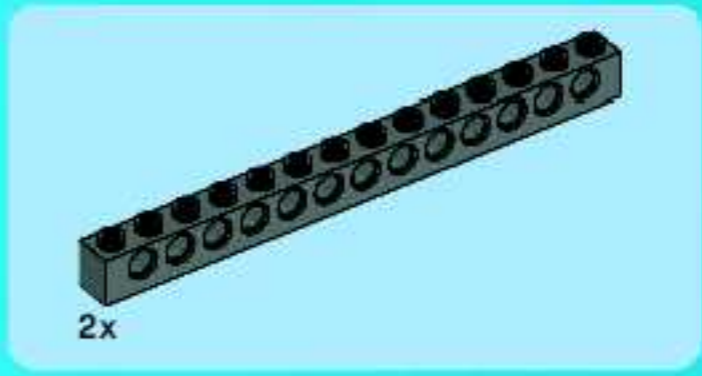
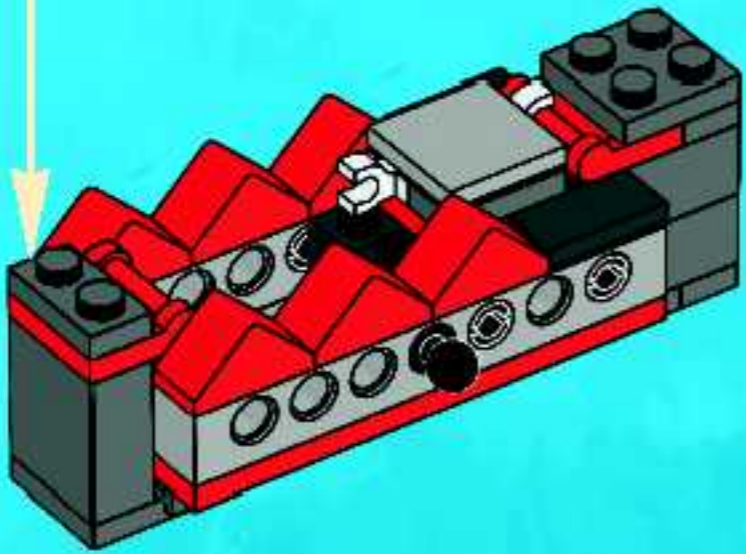
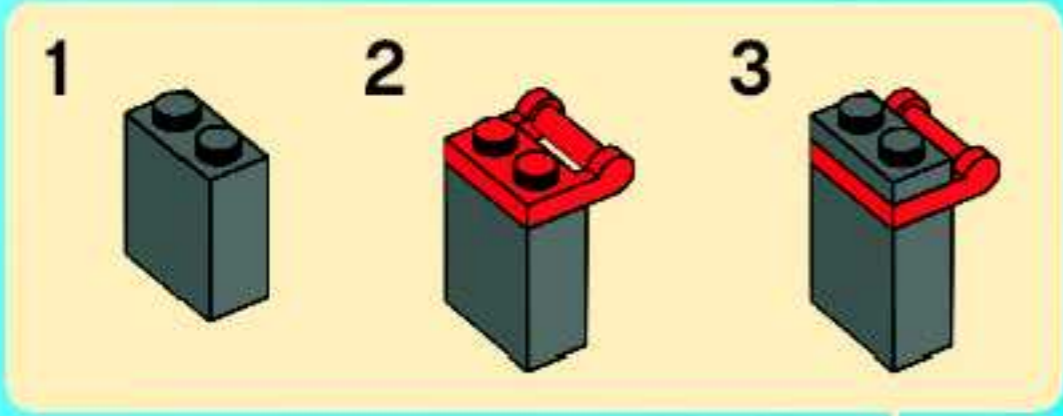

8

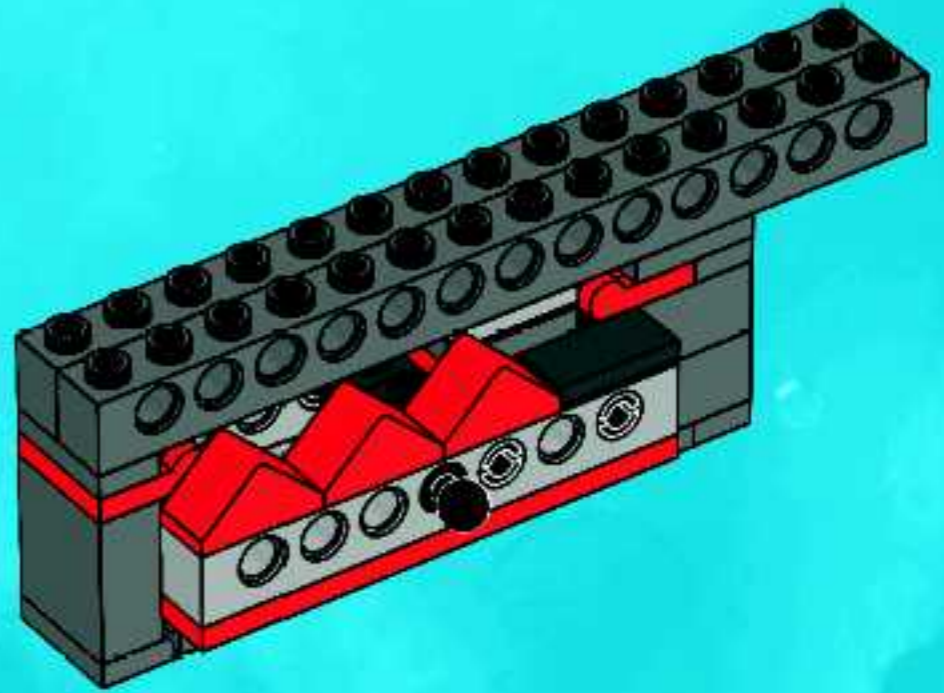



1x



2x

9

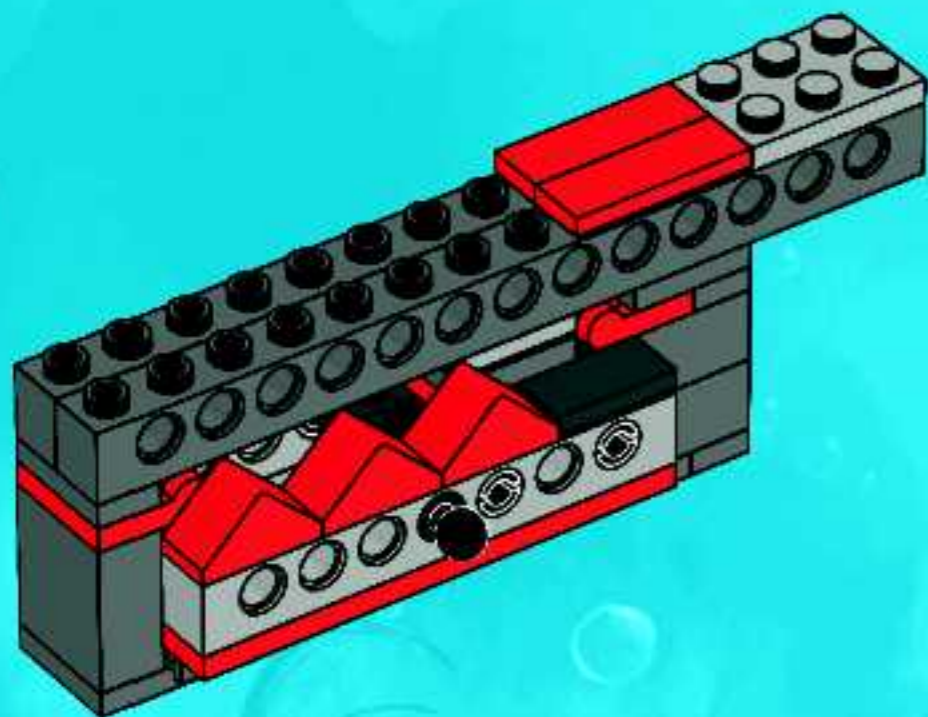

1x



1x



2x

10

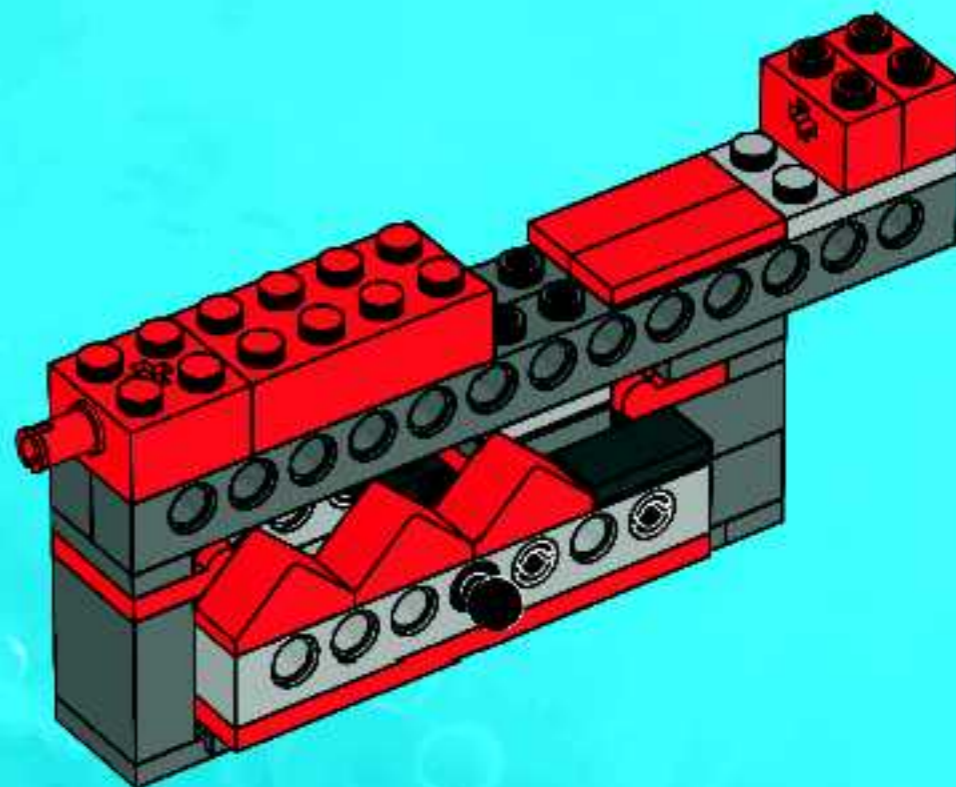



1x



1x

11

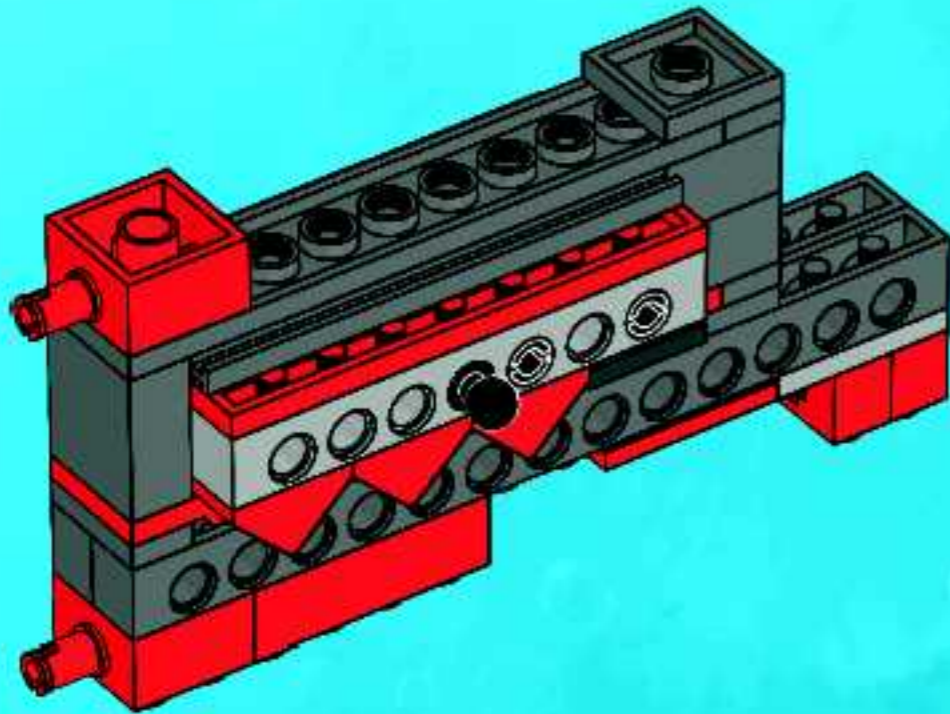

2x



1x



1x

12

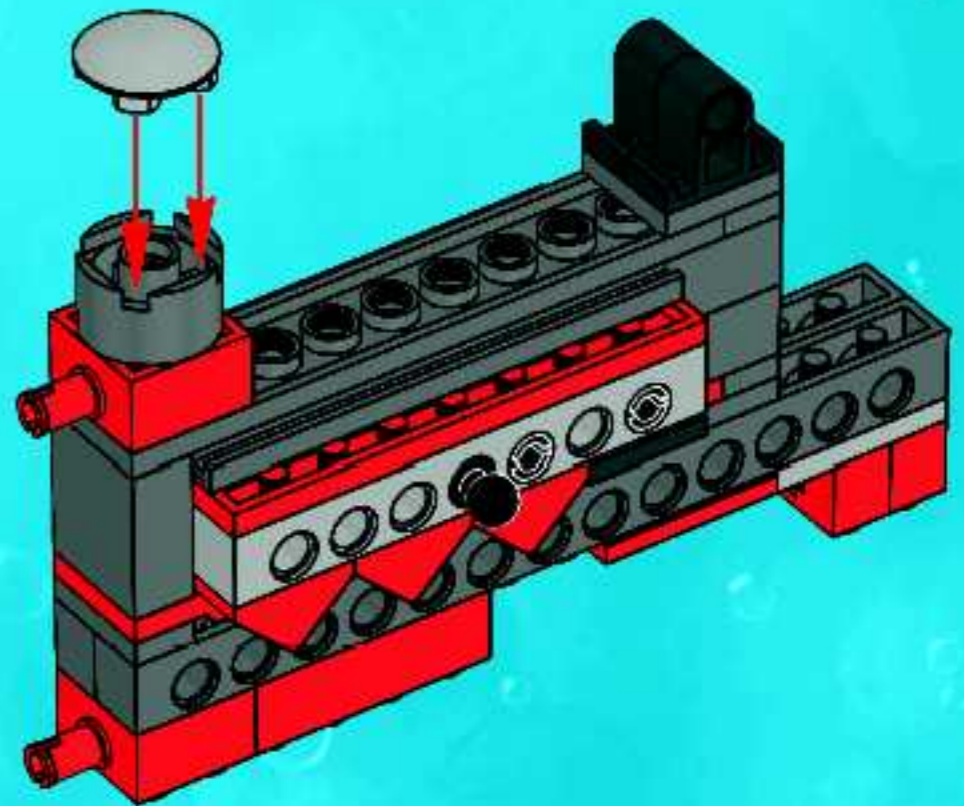

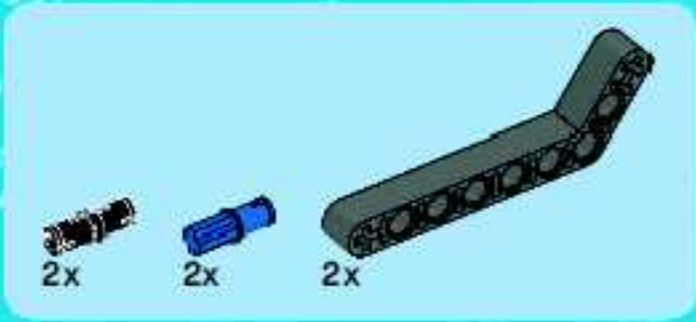

13

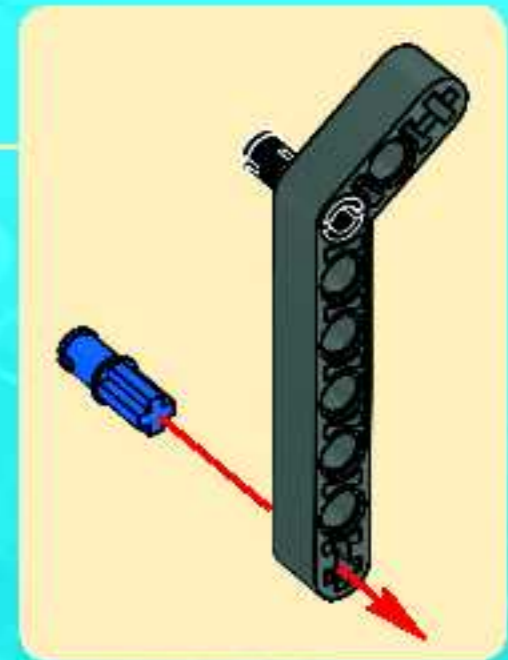
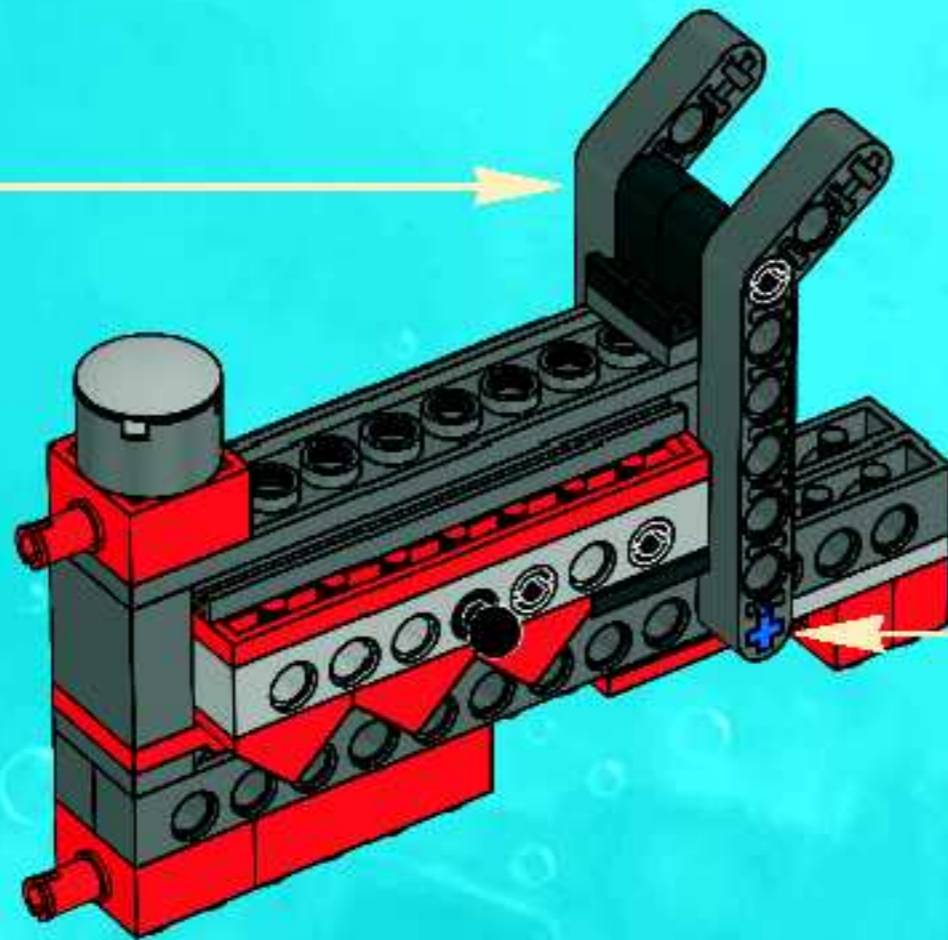
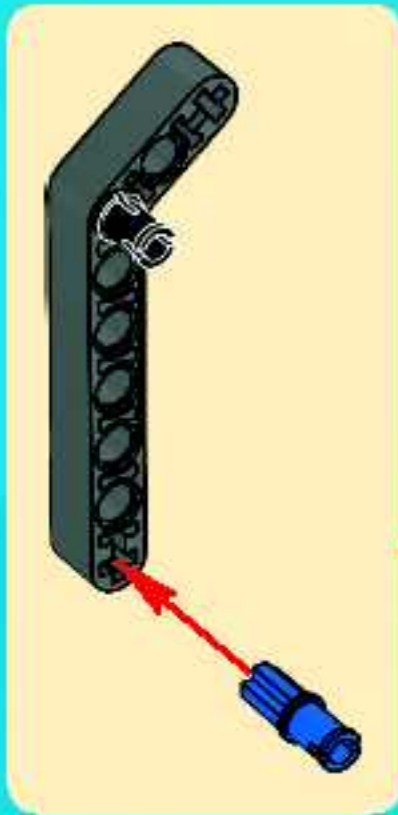



1x



1x



1x

14

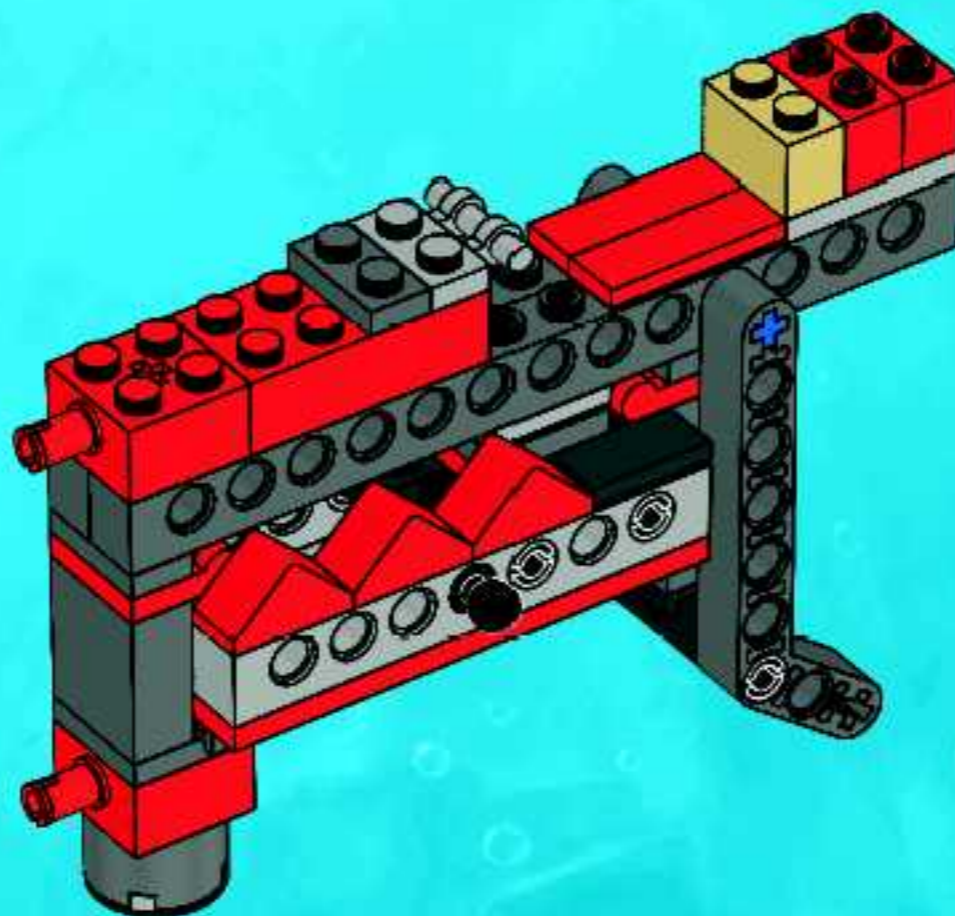

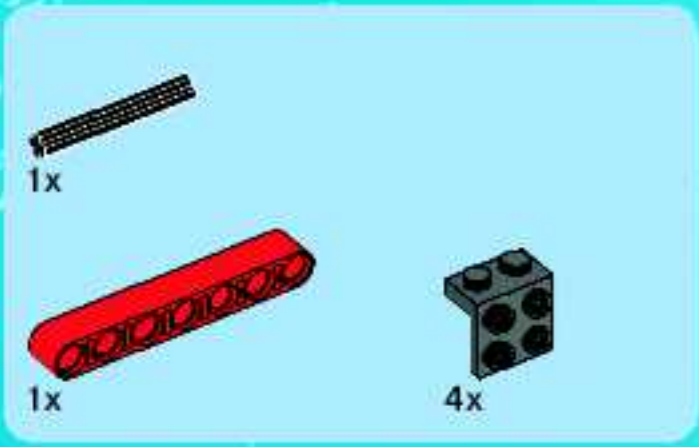

15

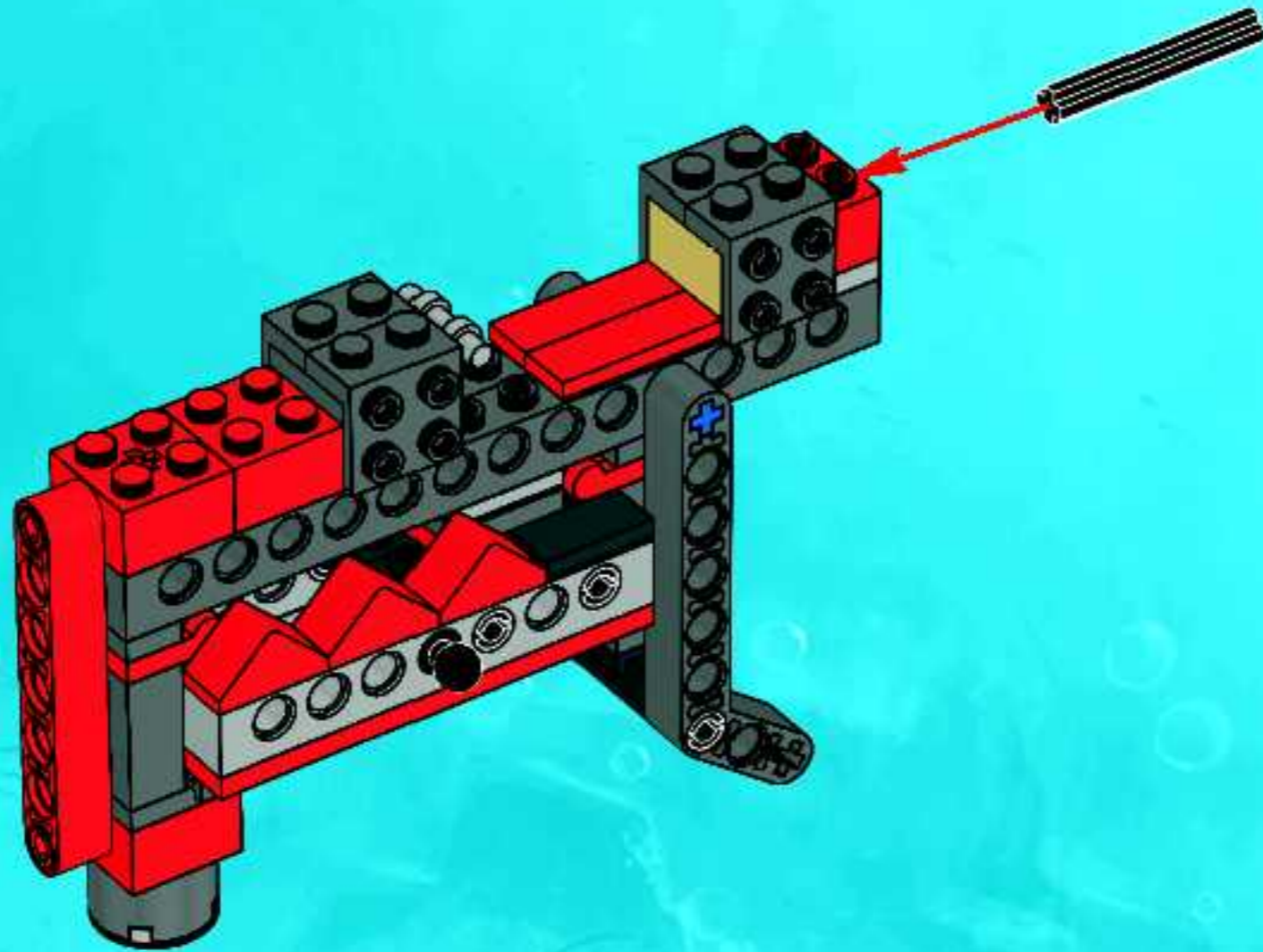



16

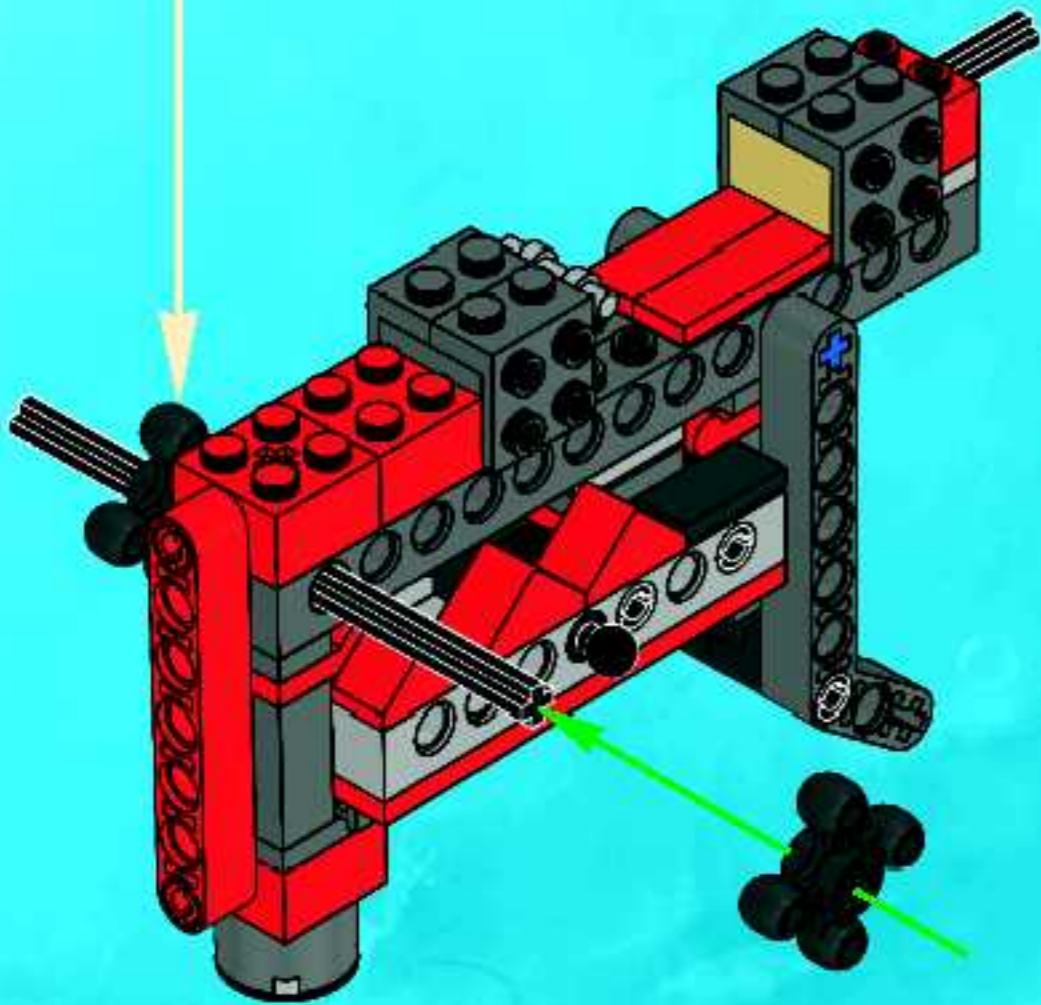
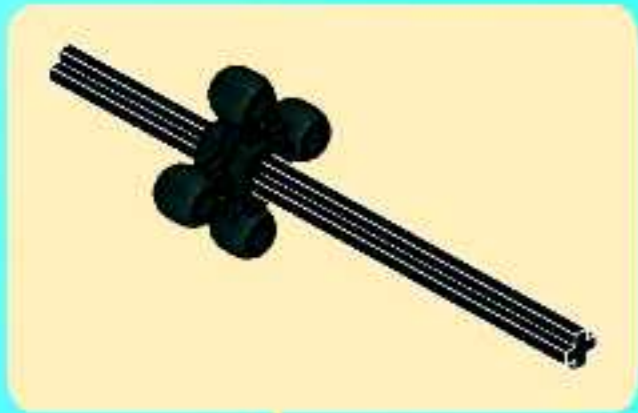

17

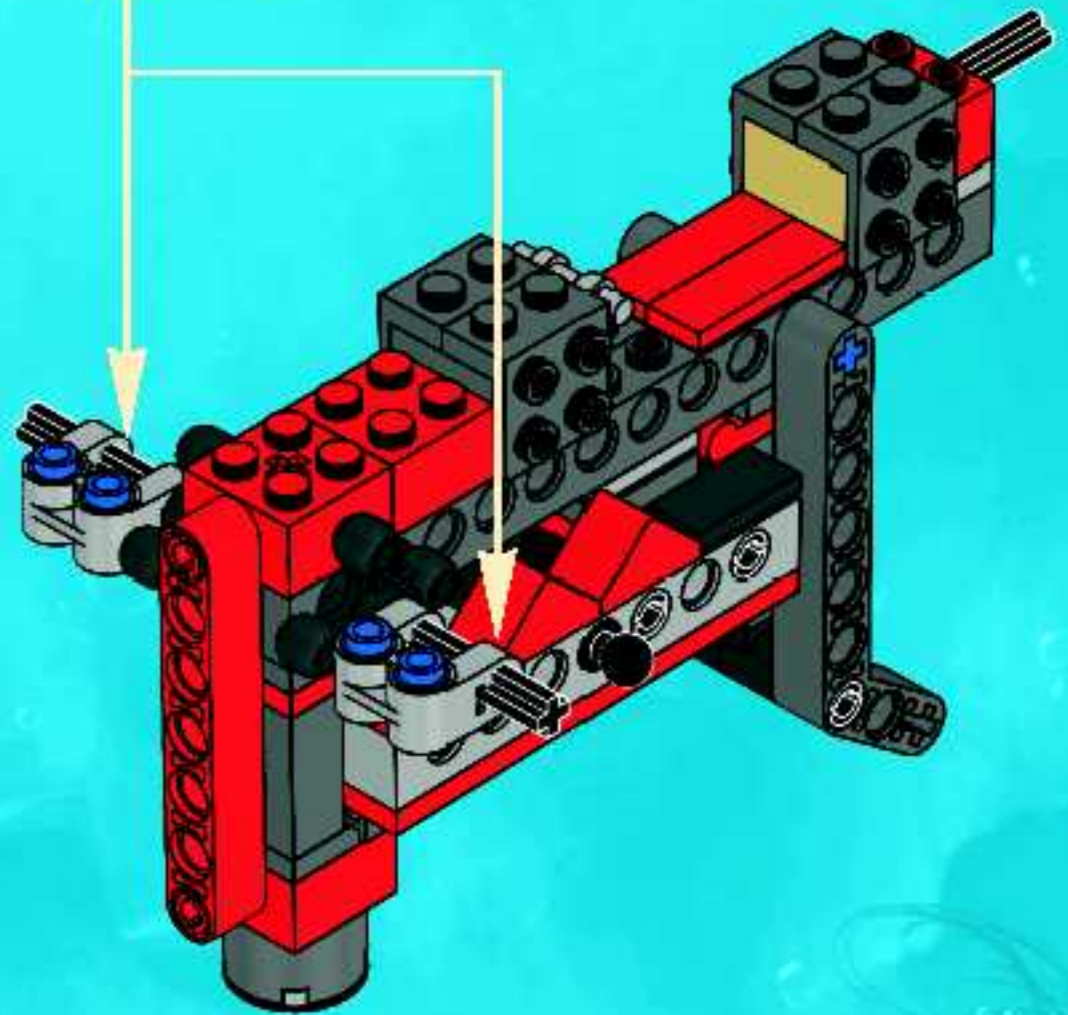
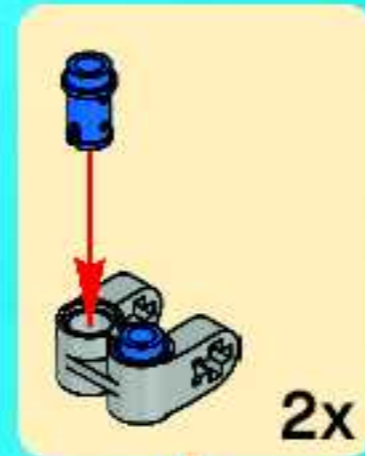



2x

18

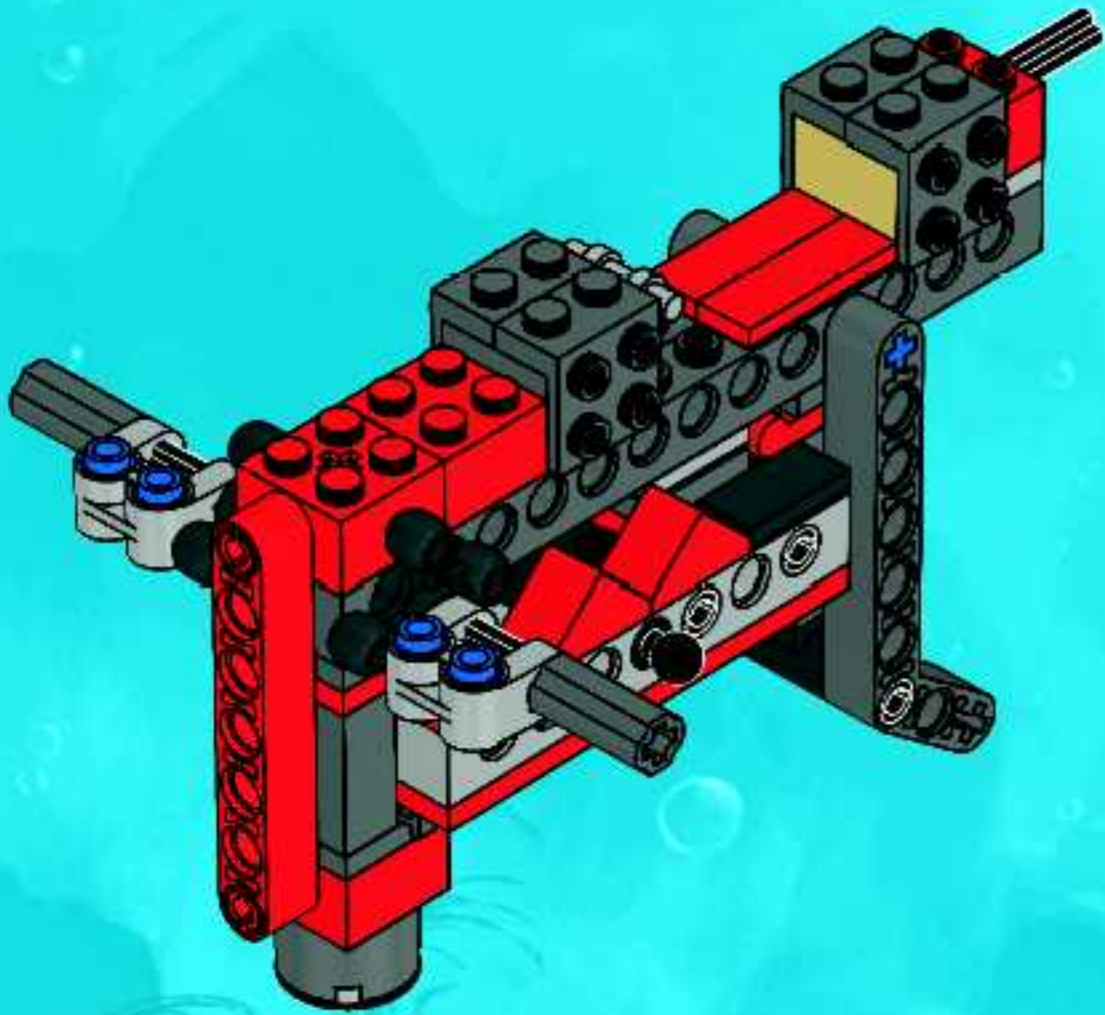

3x

1x

1x

19

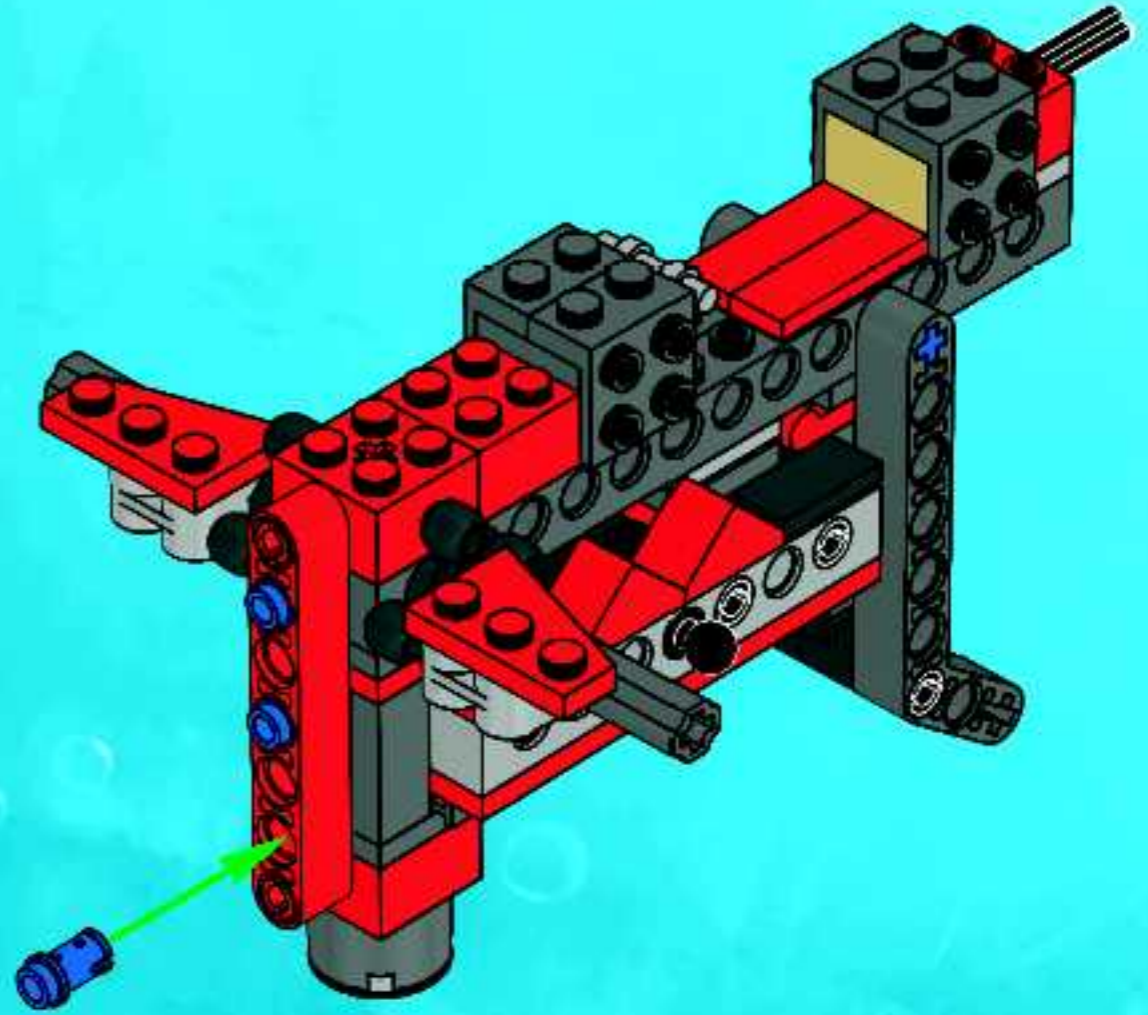

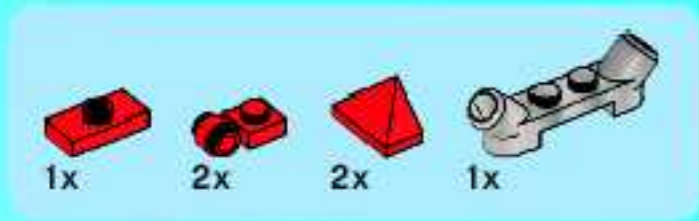

20

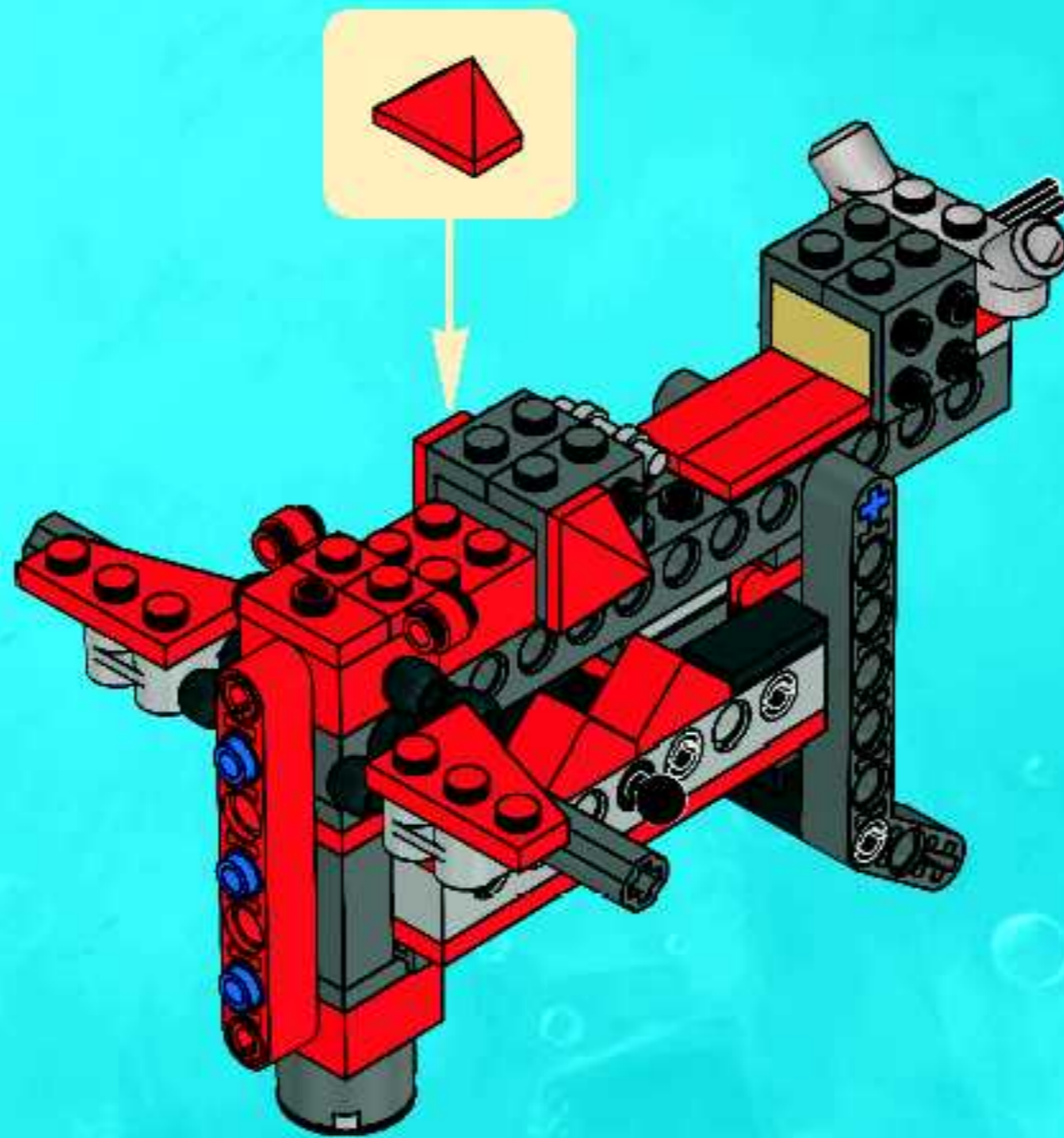

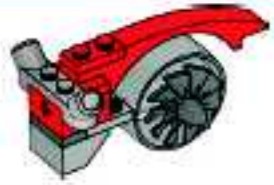

1x

1



1x



1x

2



1x



2x

3

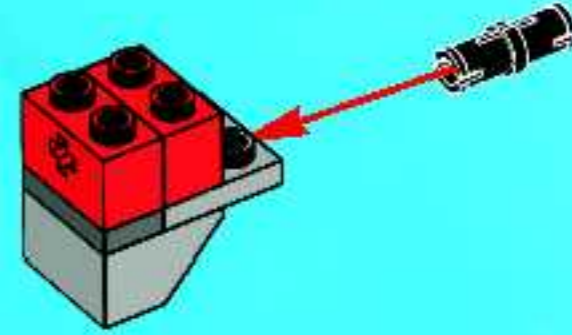

1x



1x



1x

4

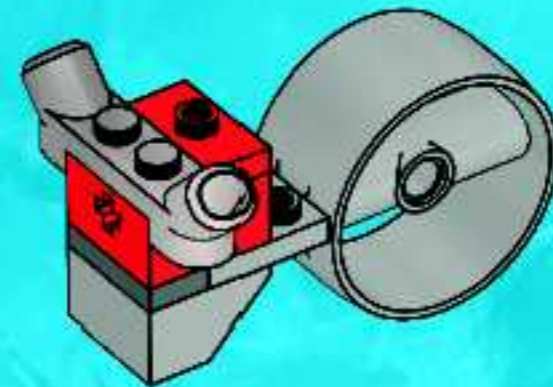

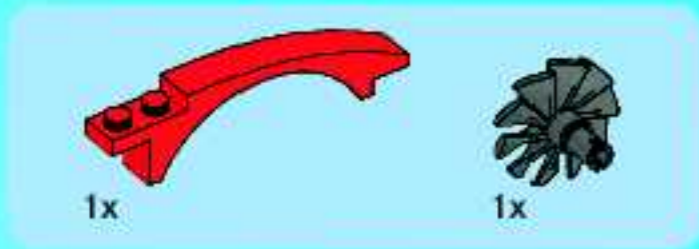

5

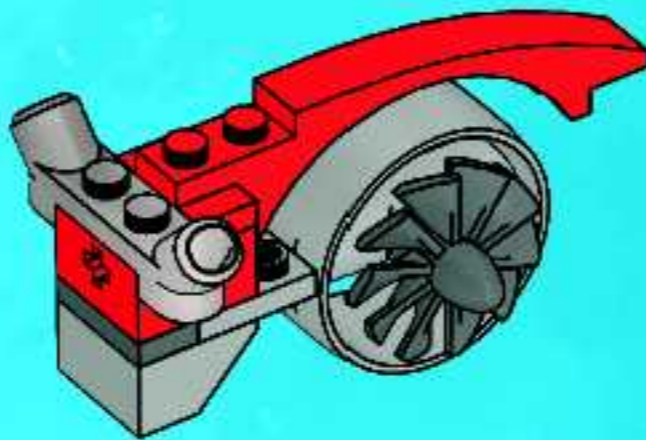

6

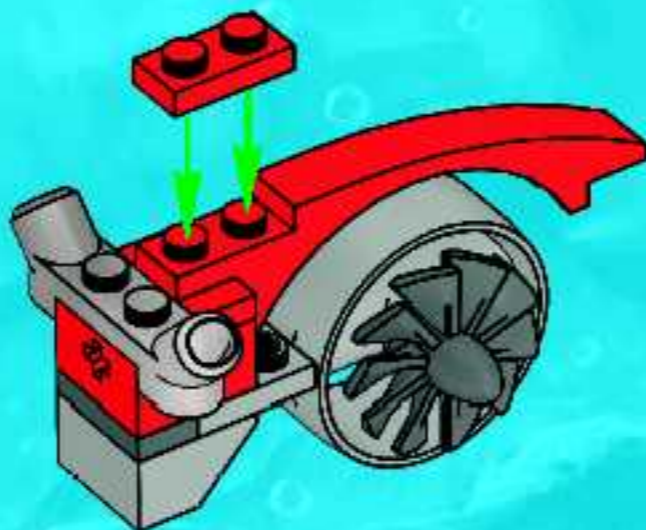

21

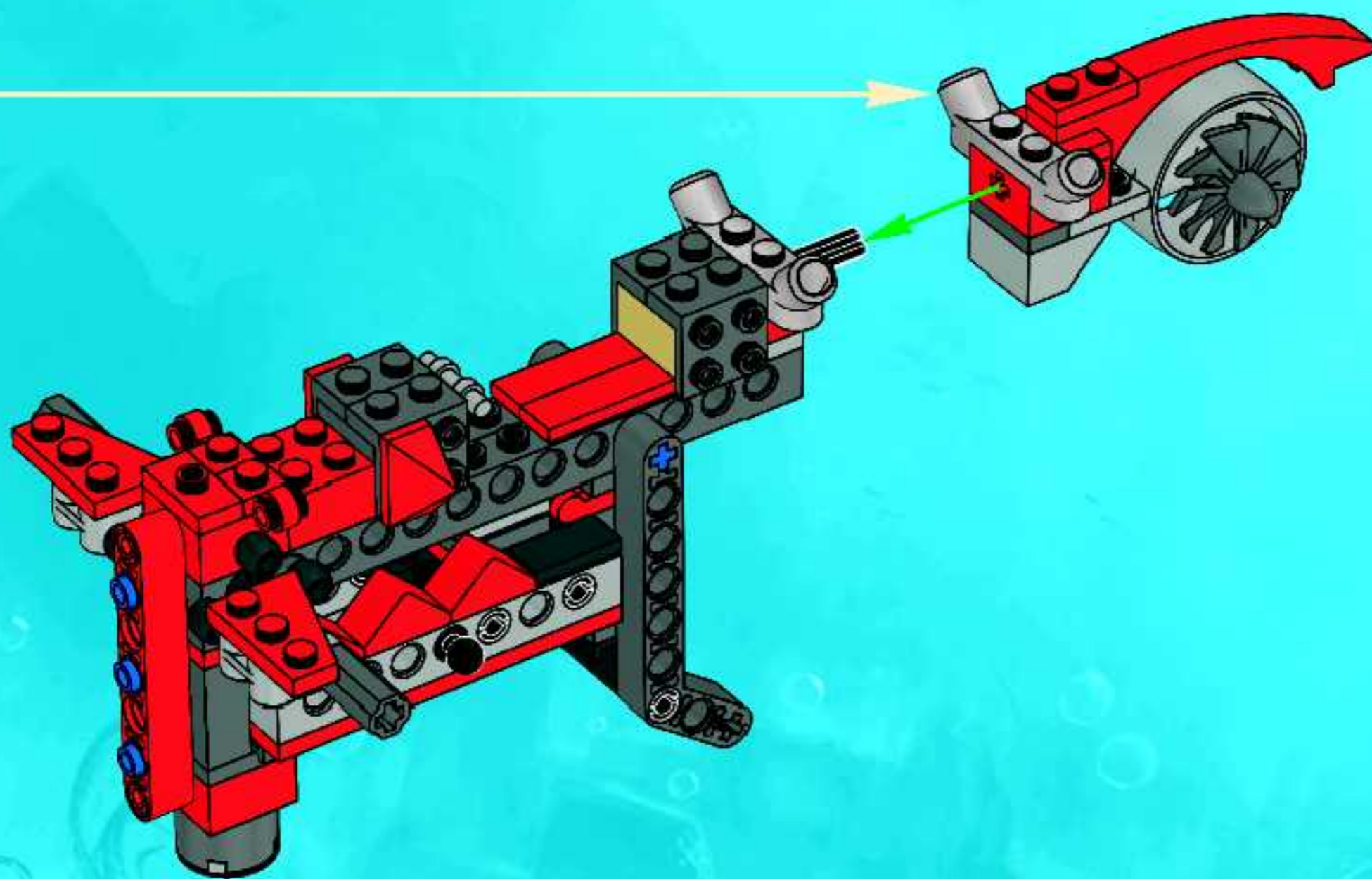



1x



1x



1x

22

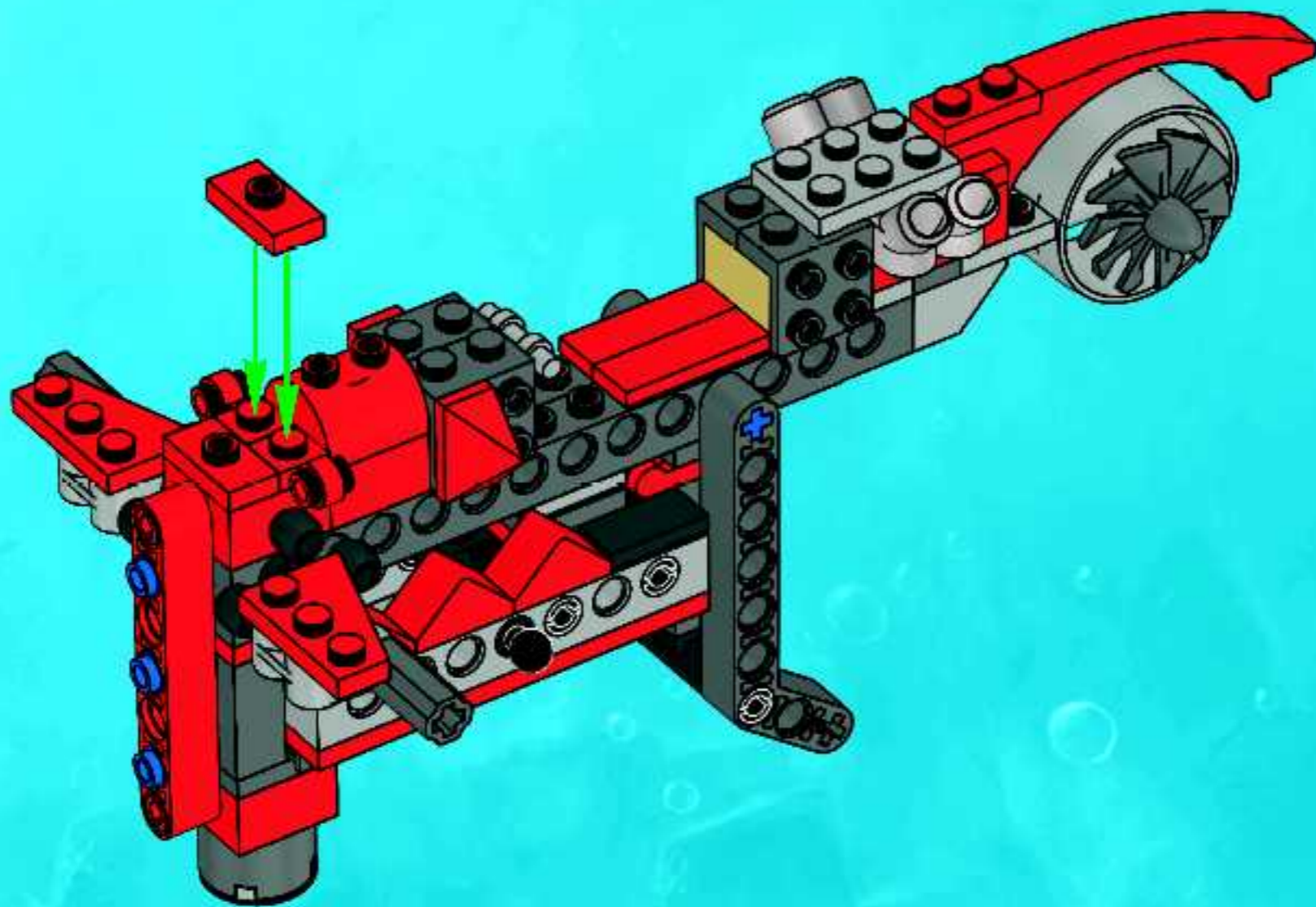

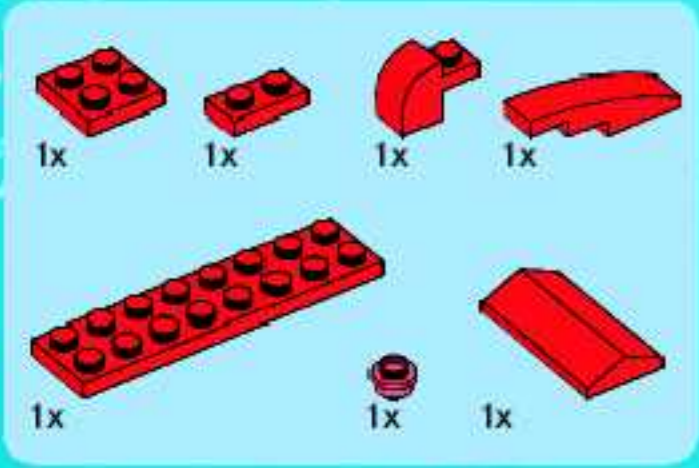

23

1



2

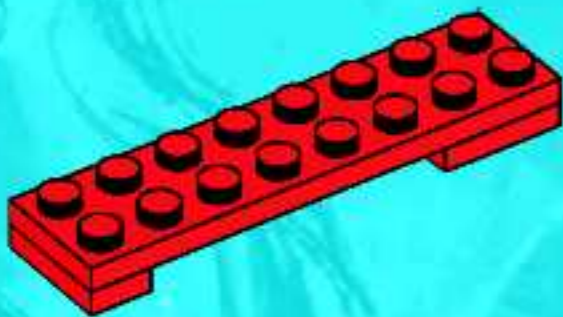

3

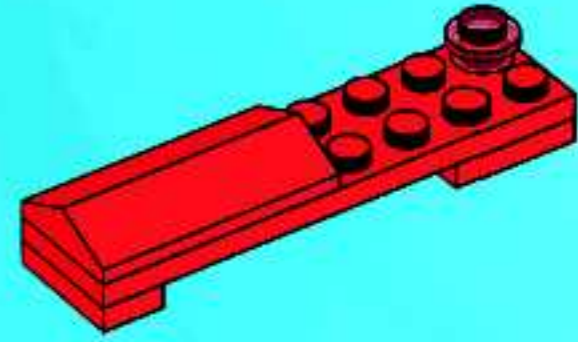

4

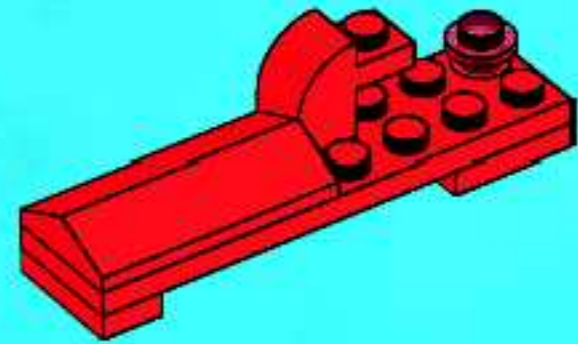

5

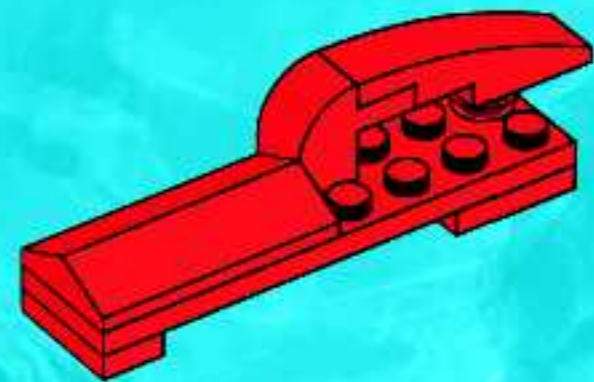

6

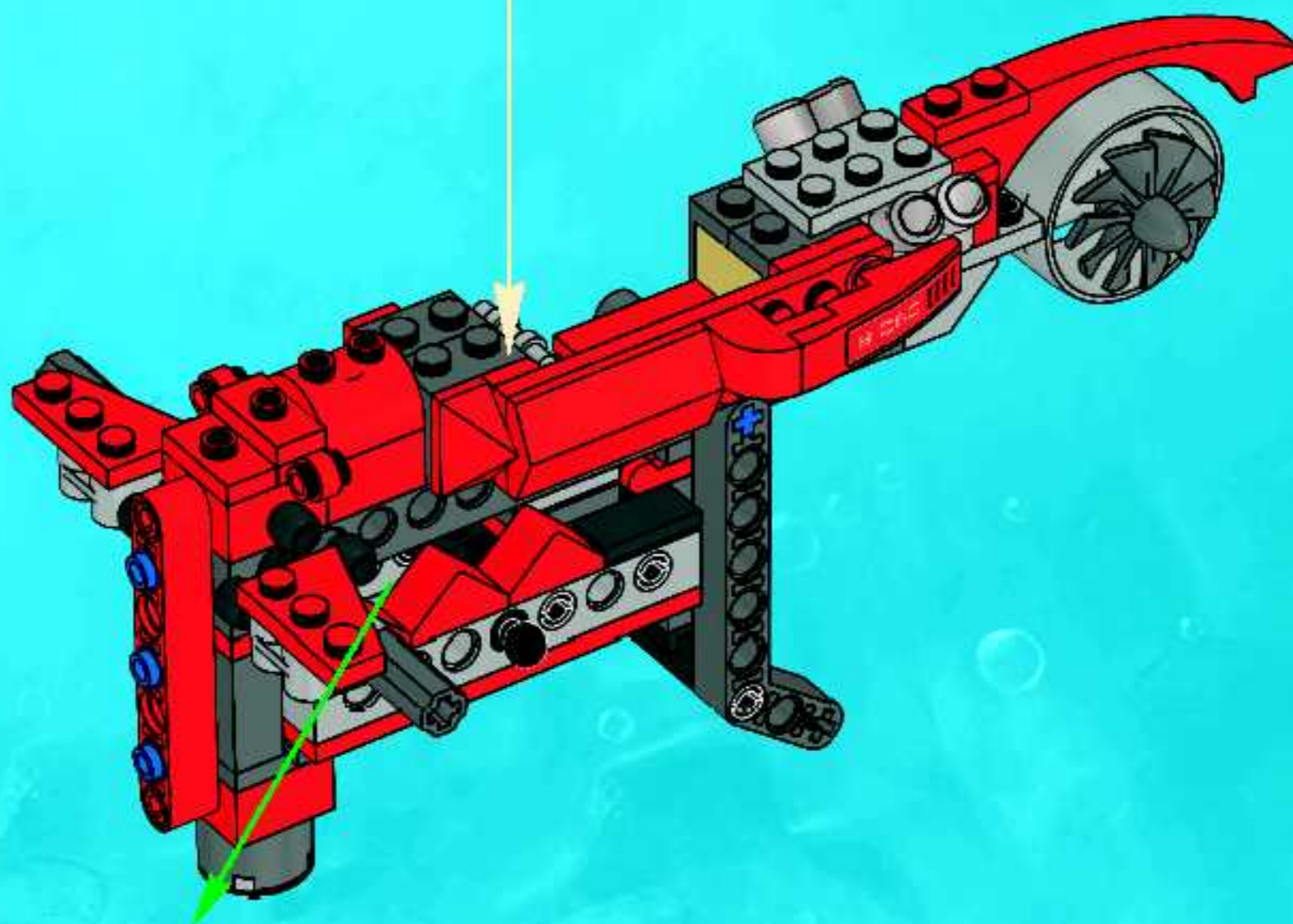
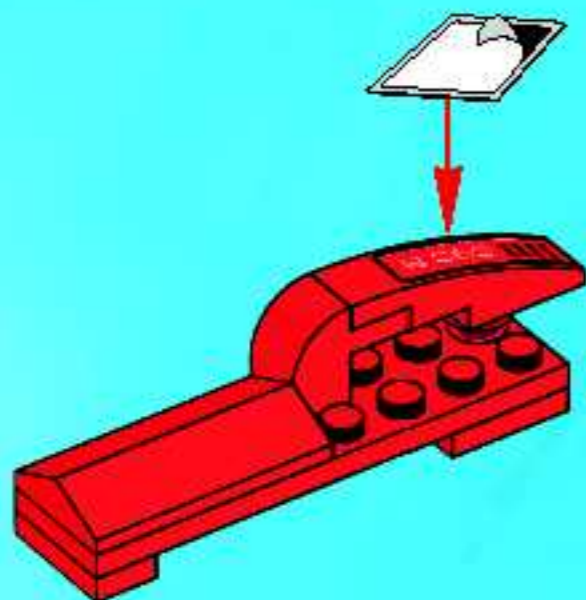

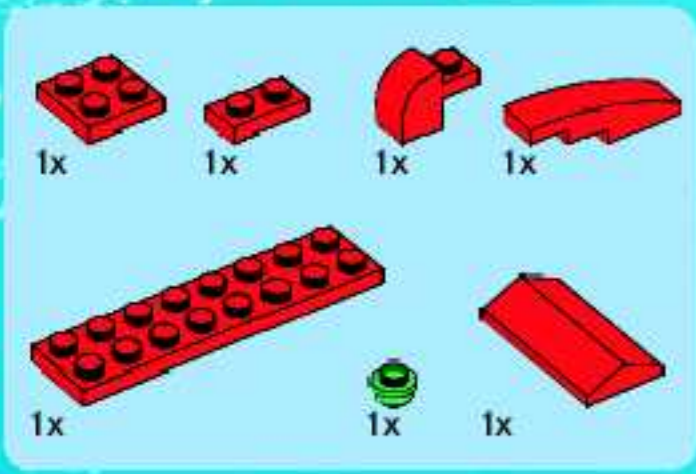

24

1

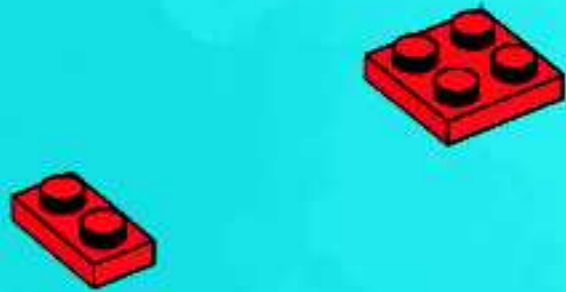

2

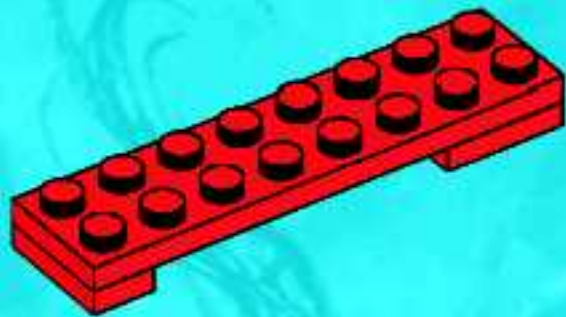

3

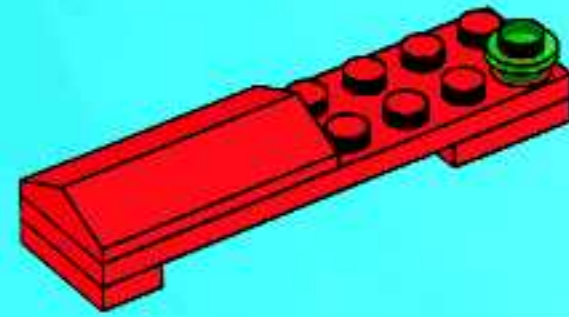

4

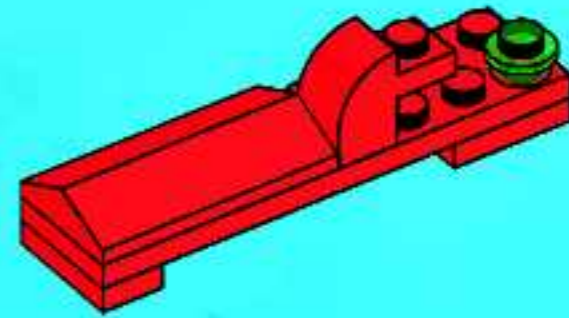

5

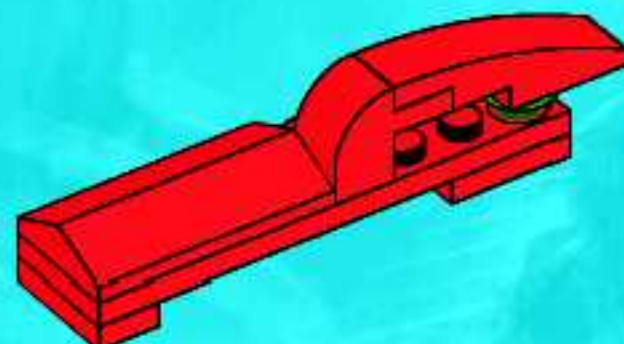

6

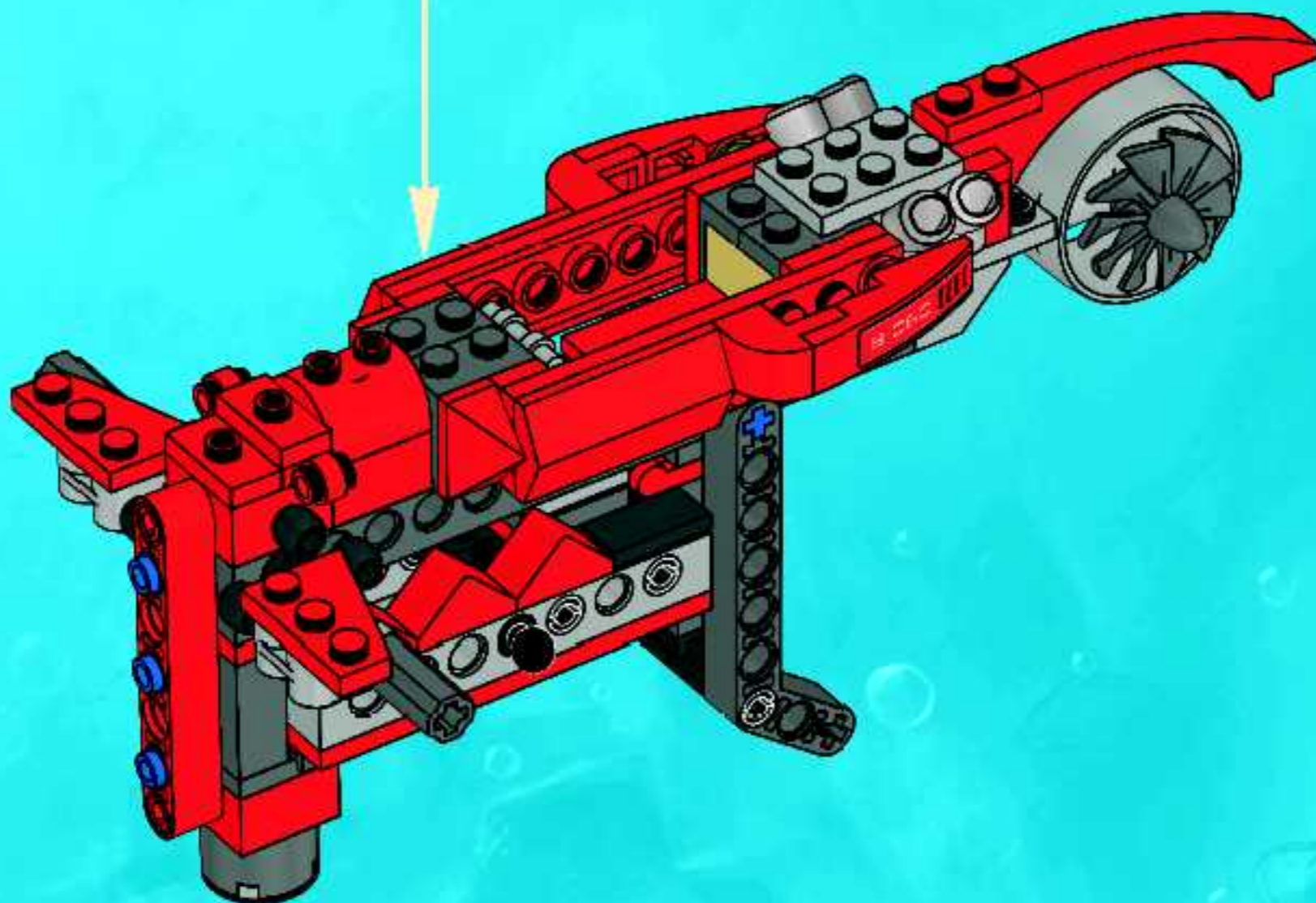
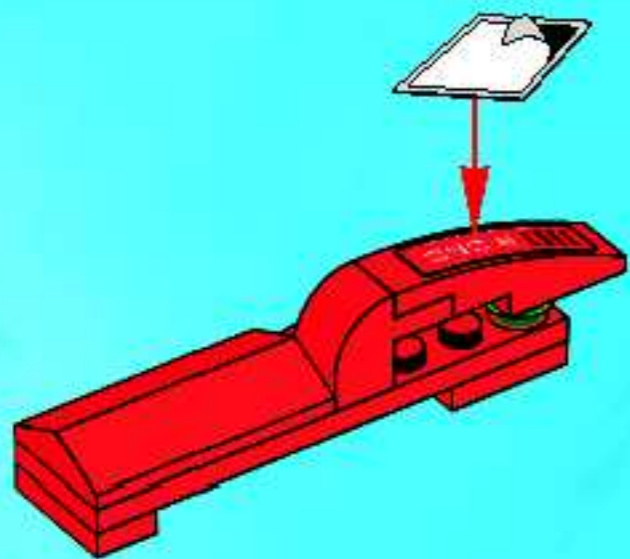

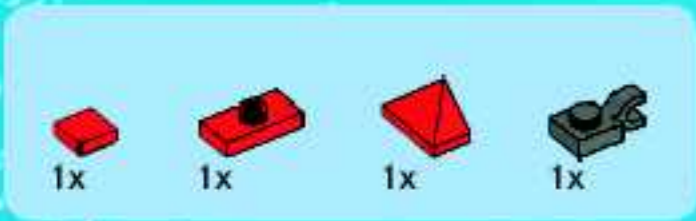

25

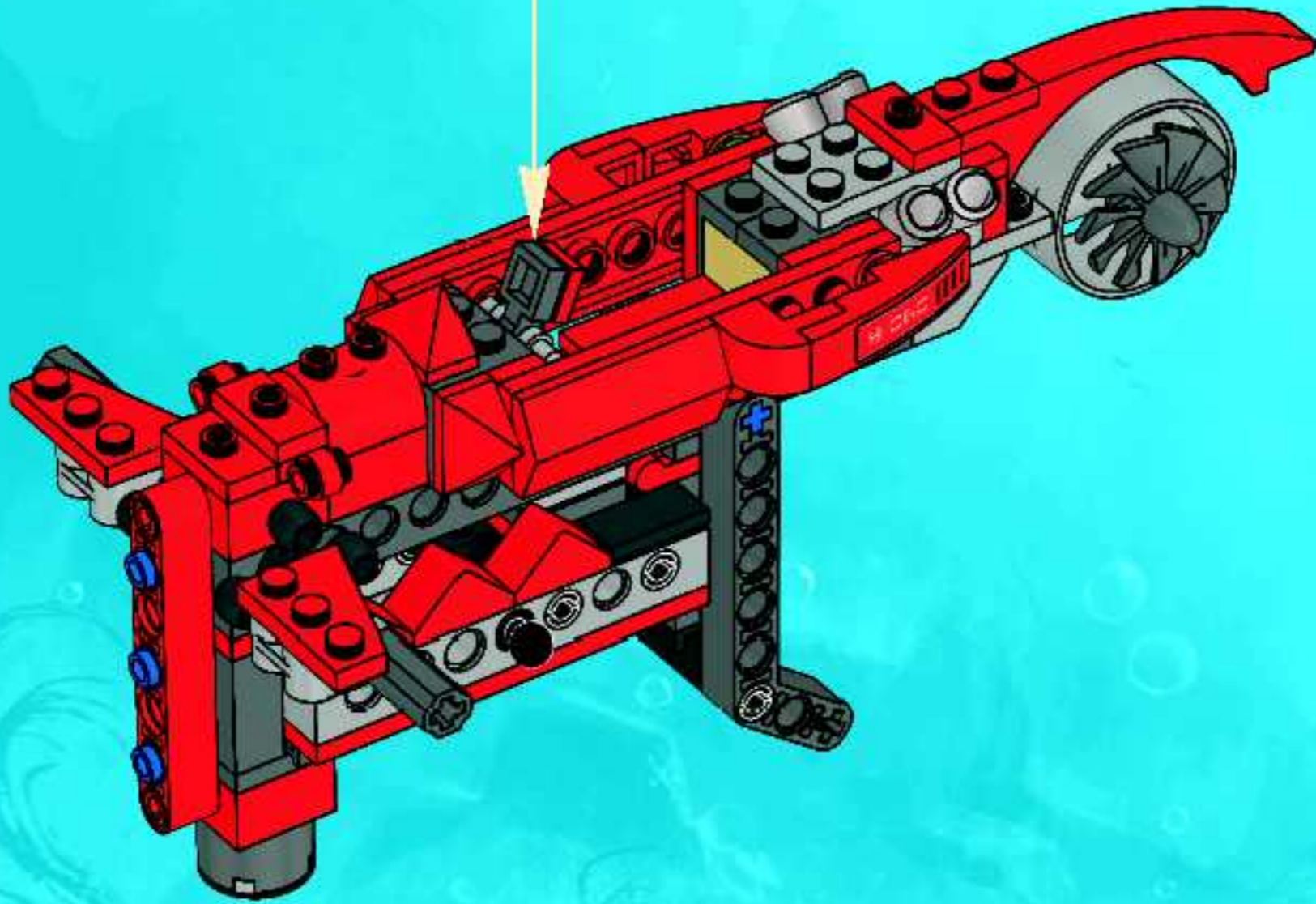
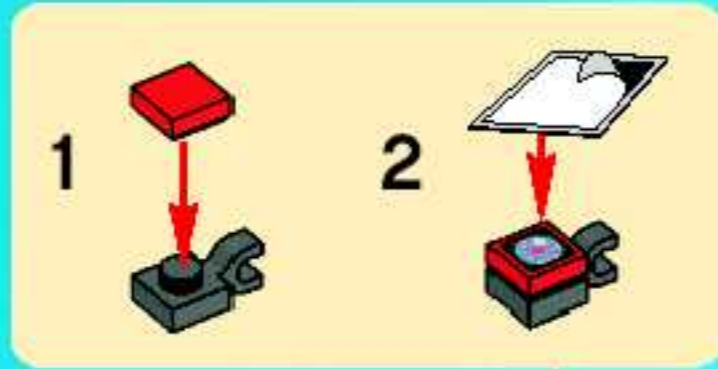

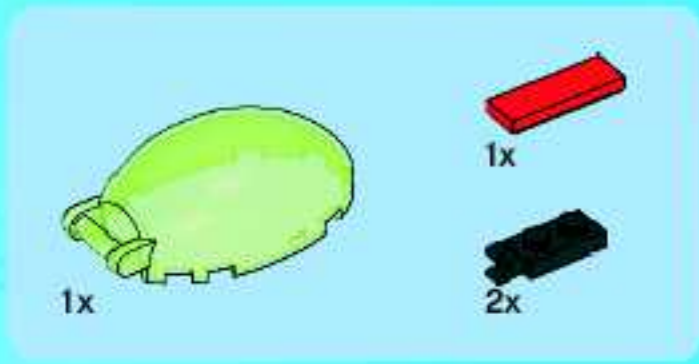

26

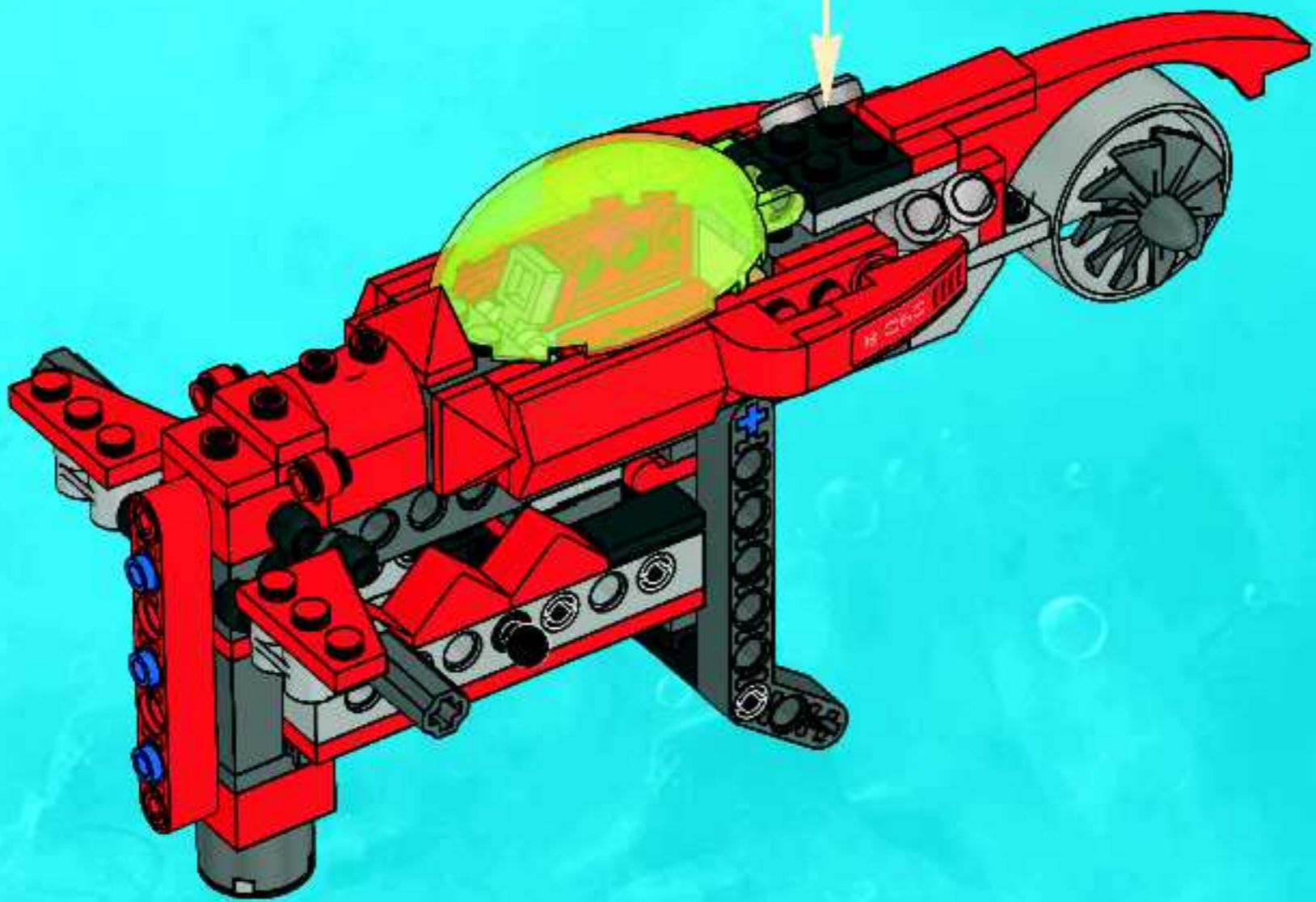
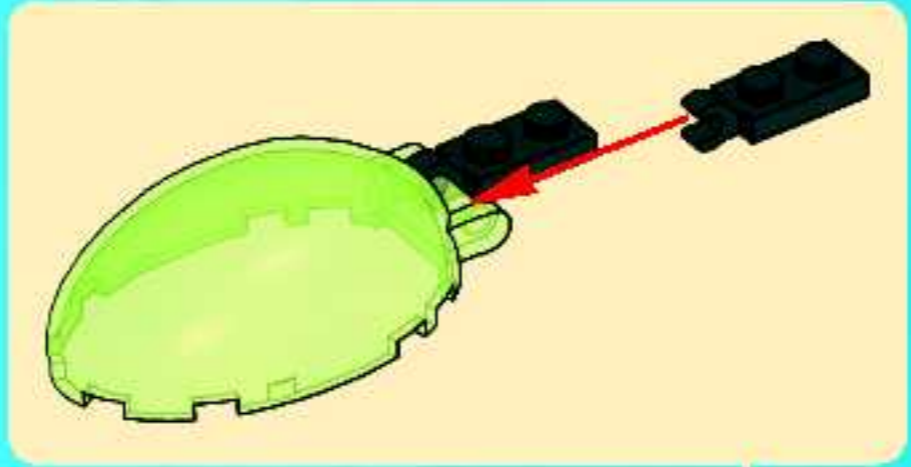

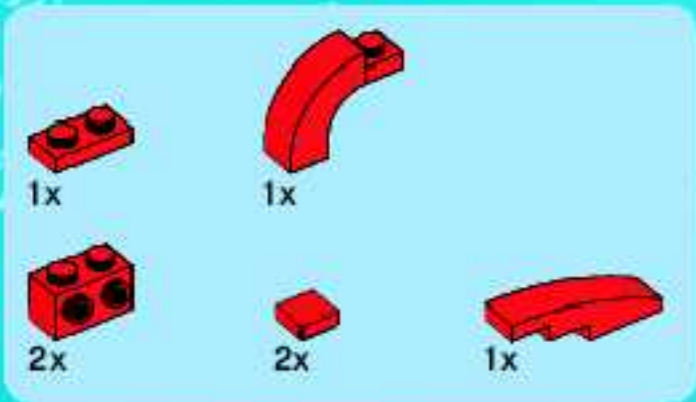

27

1



2



3

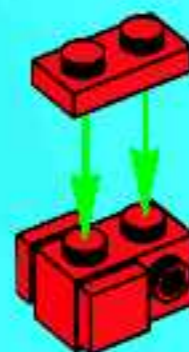

4

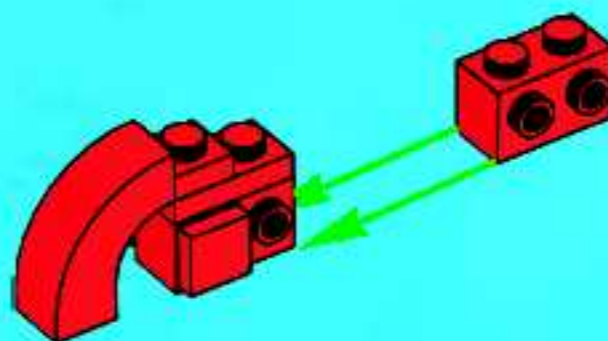

5

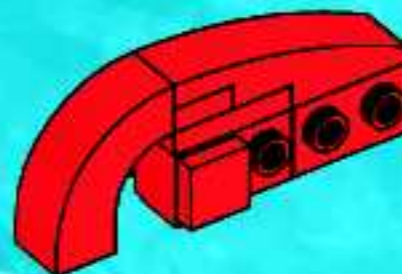

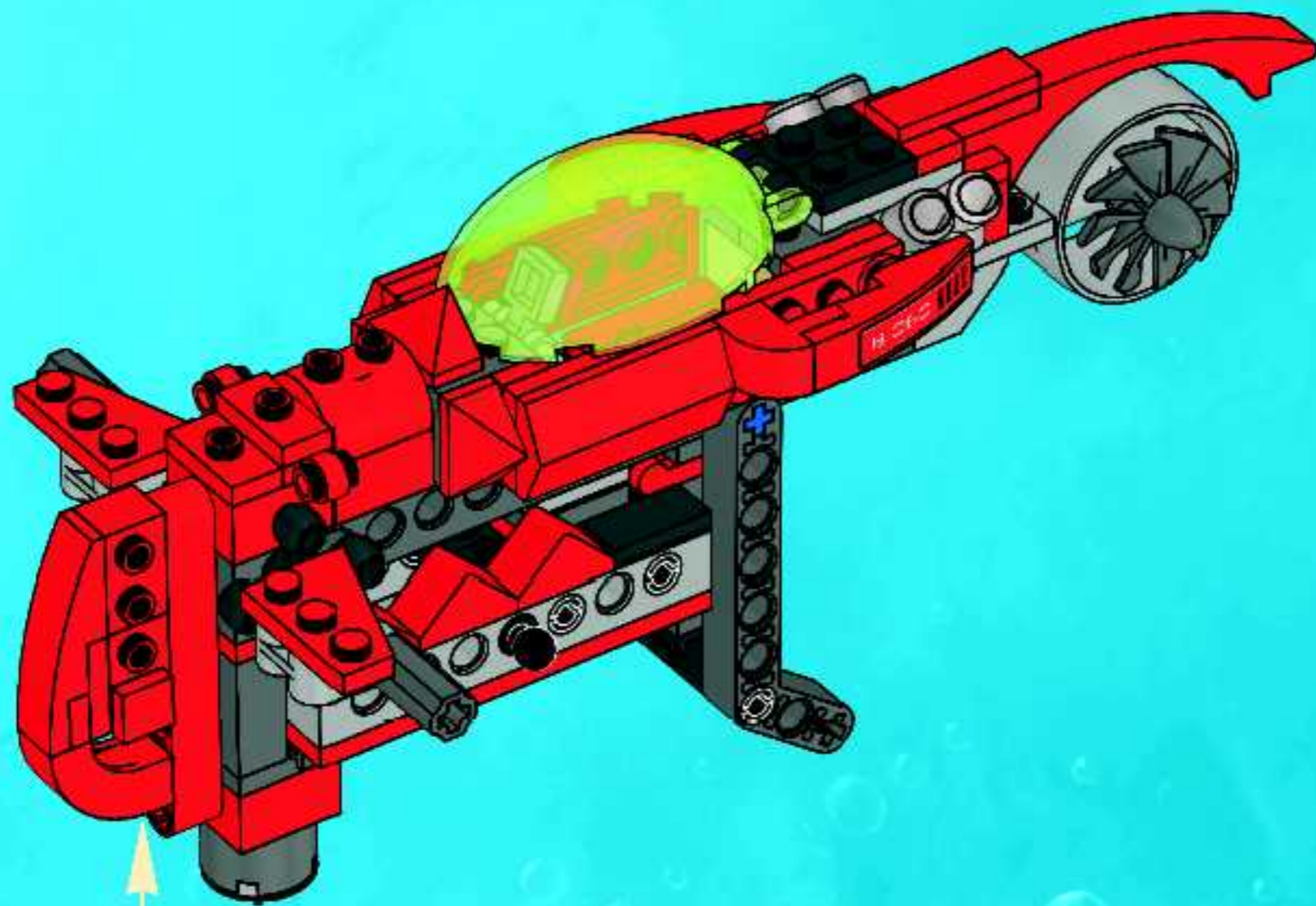



1x



1x

28

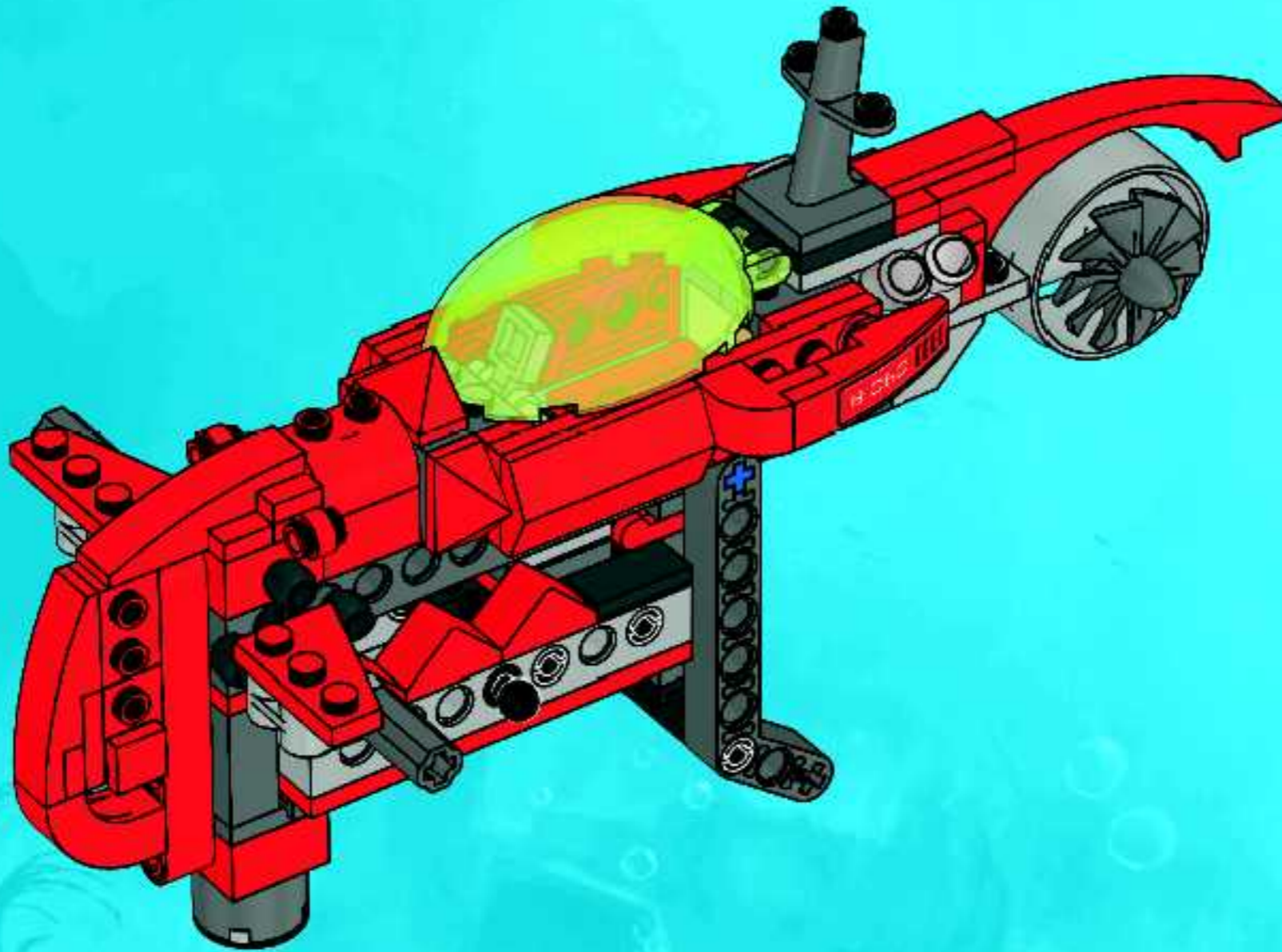

- 1x 
- 4x 
- 1x 
- 1x 
- 2x 

29

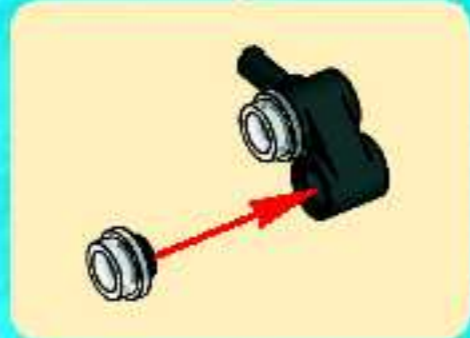
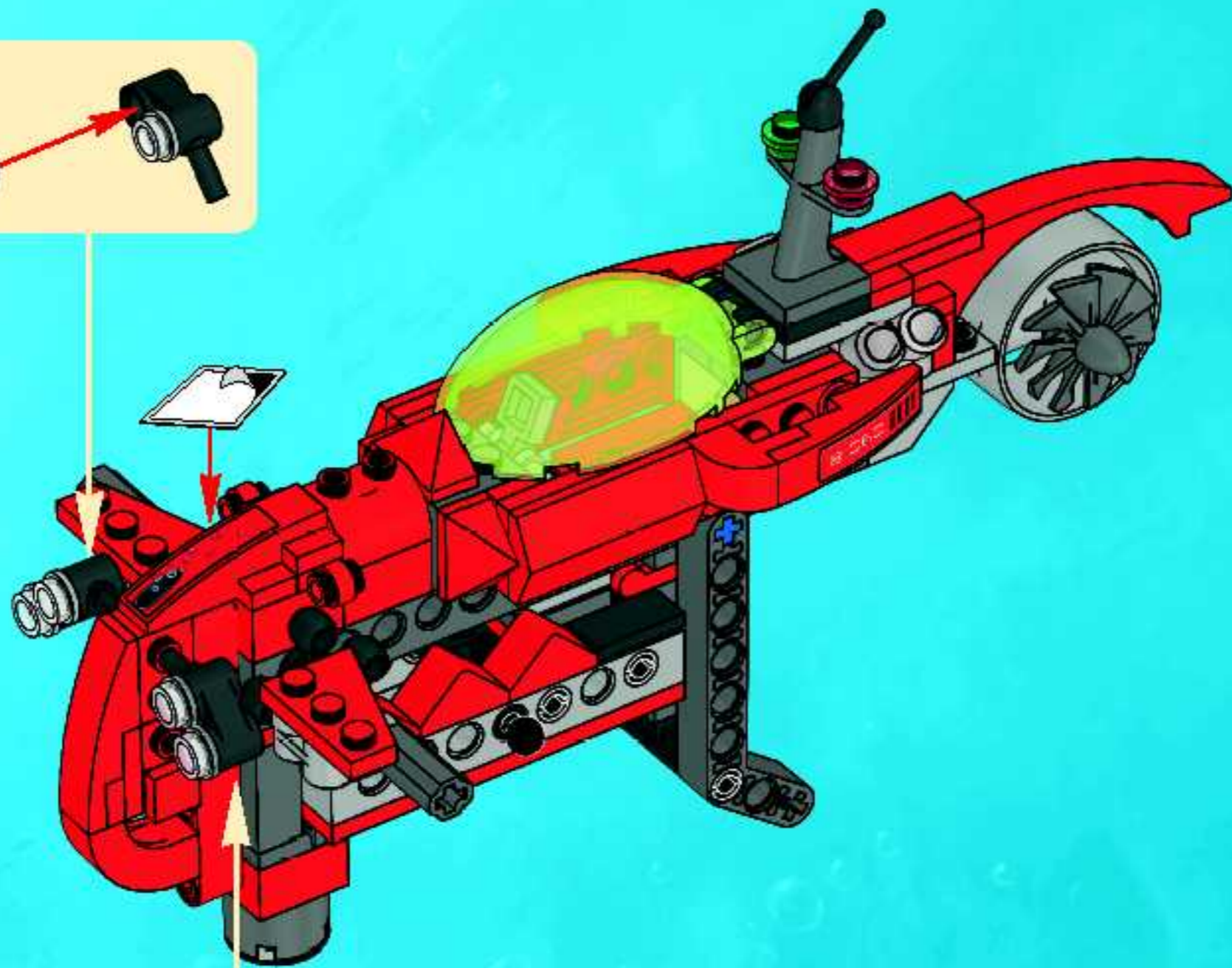
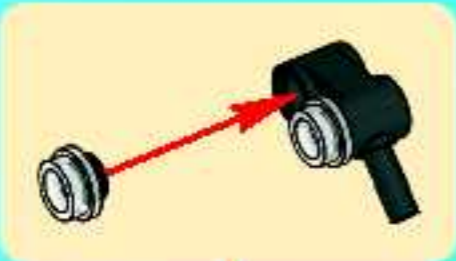

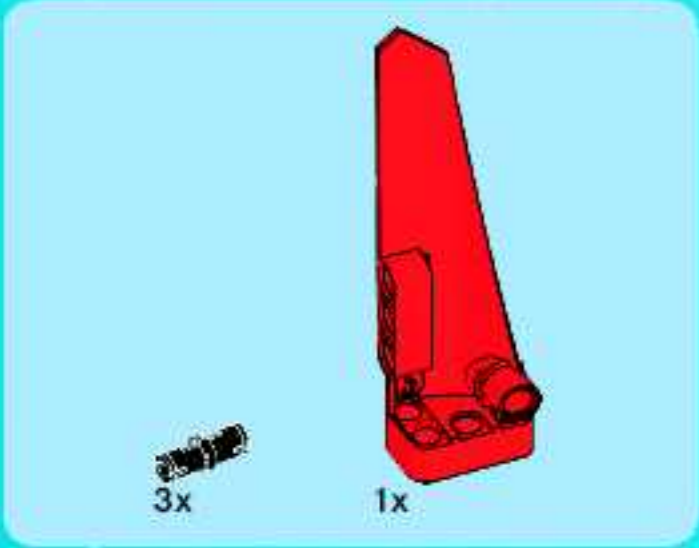
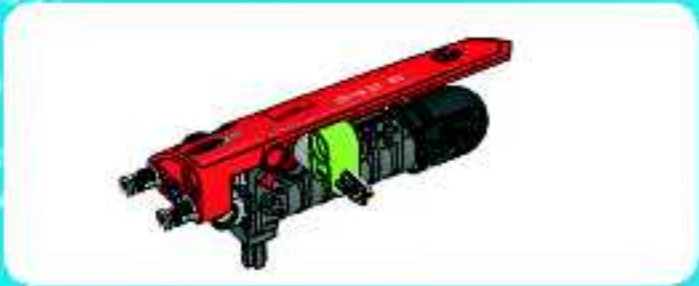

1

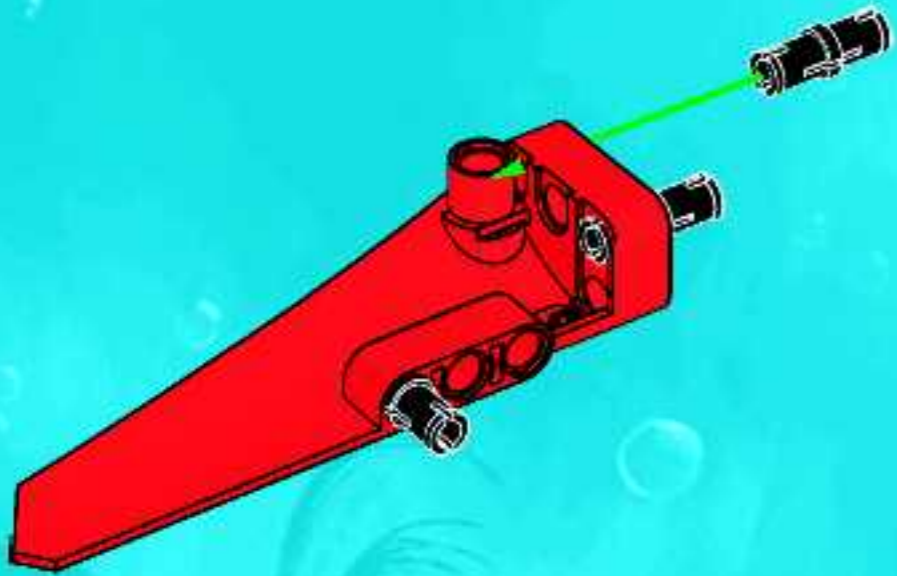

2

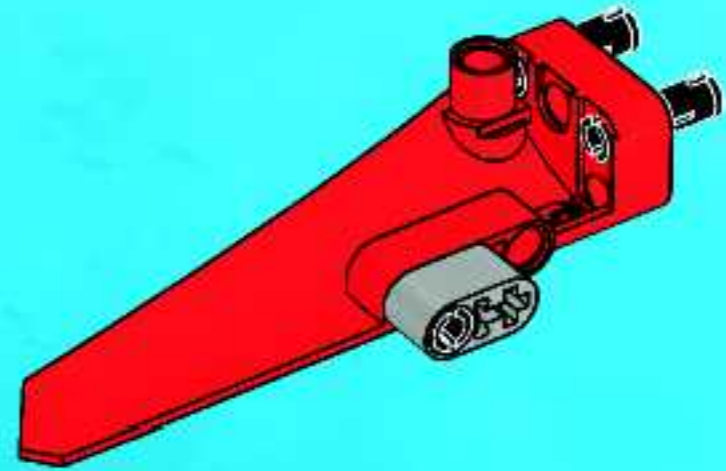



1x

3

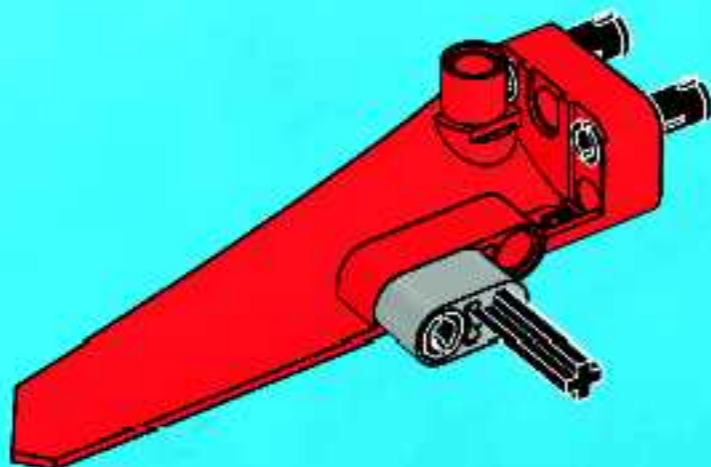

1x

4

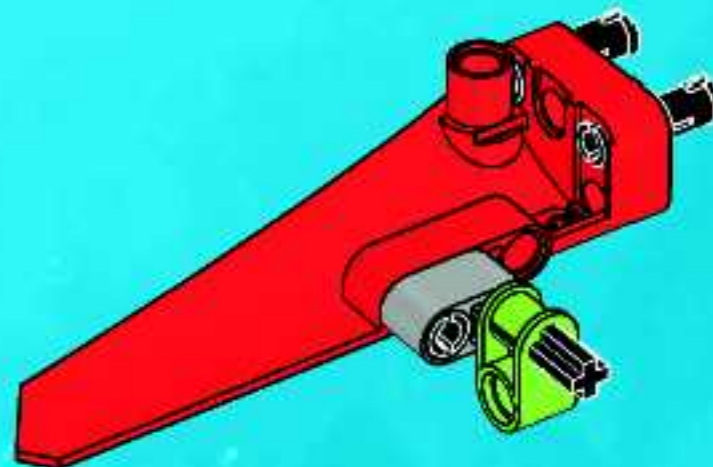

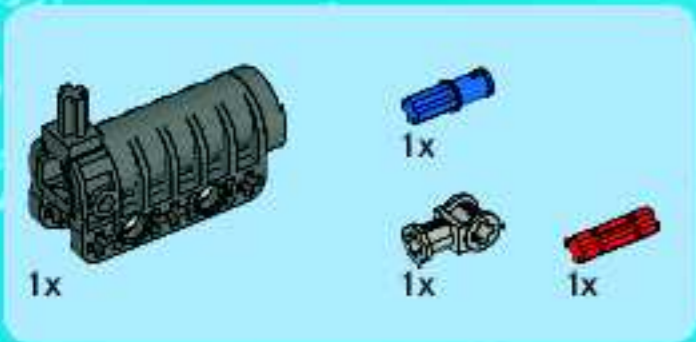

5

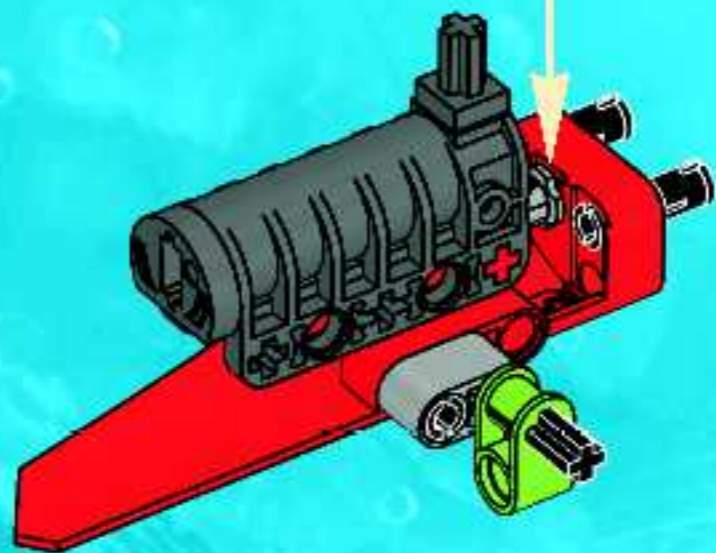
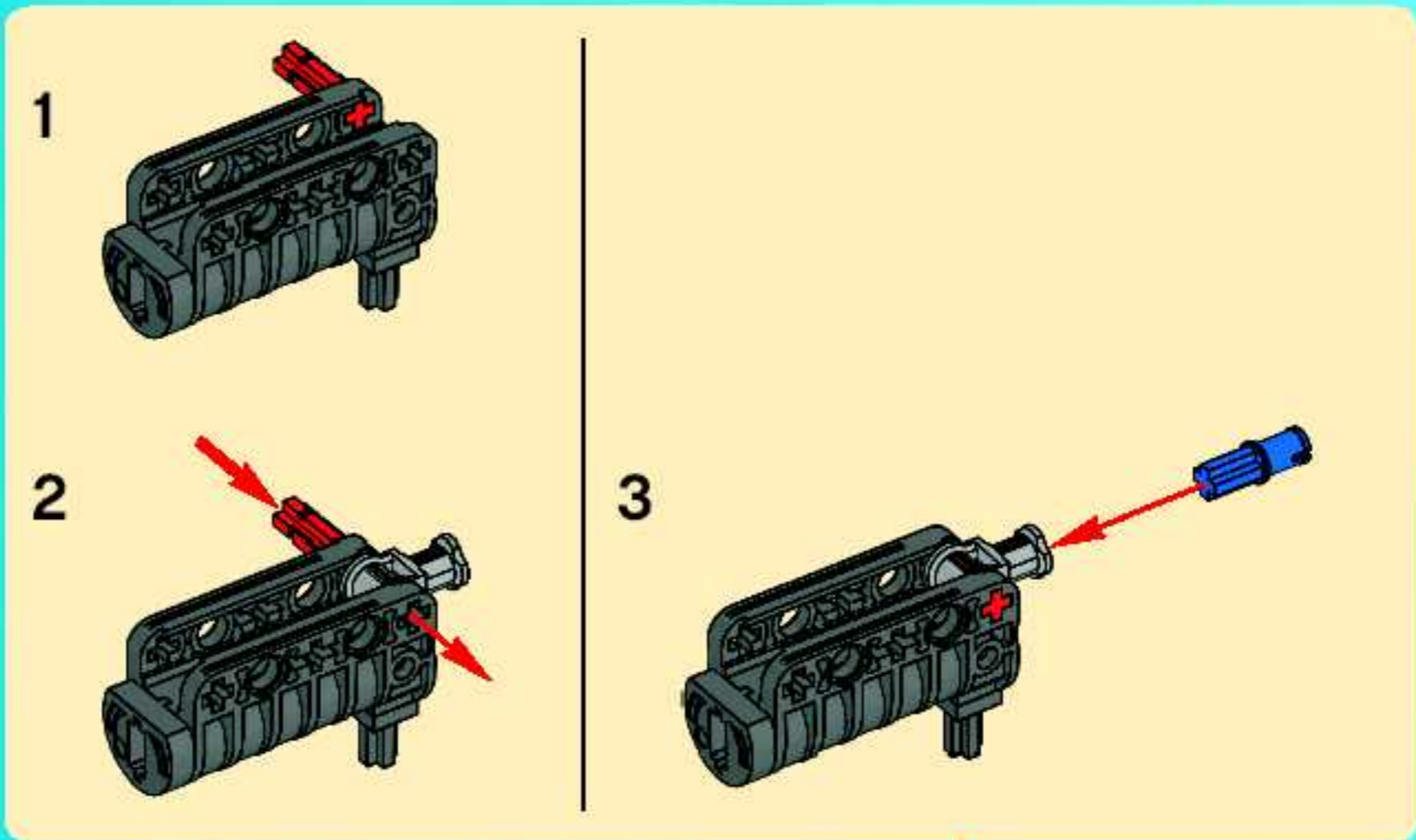

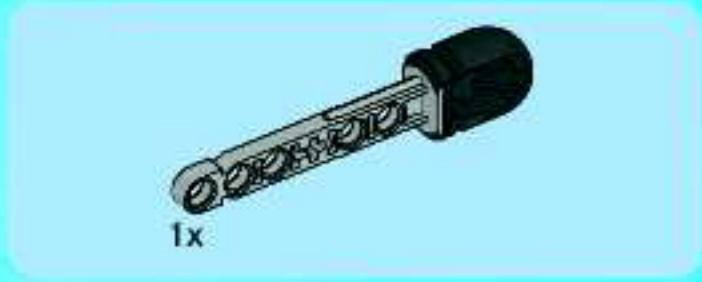

6

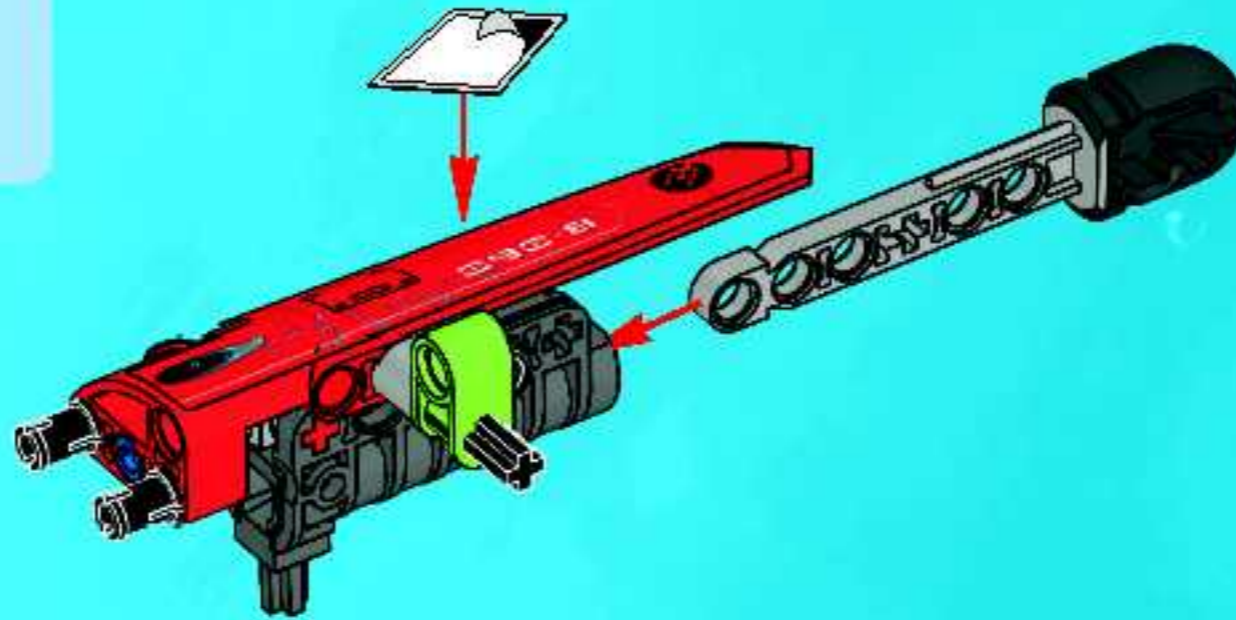

30

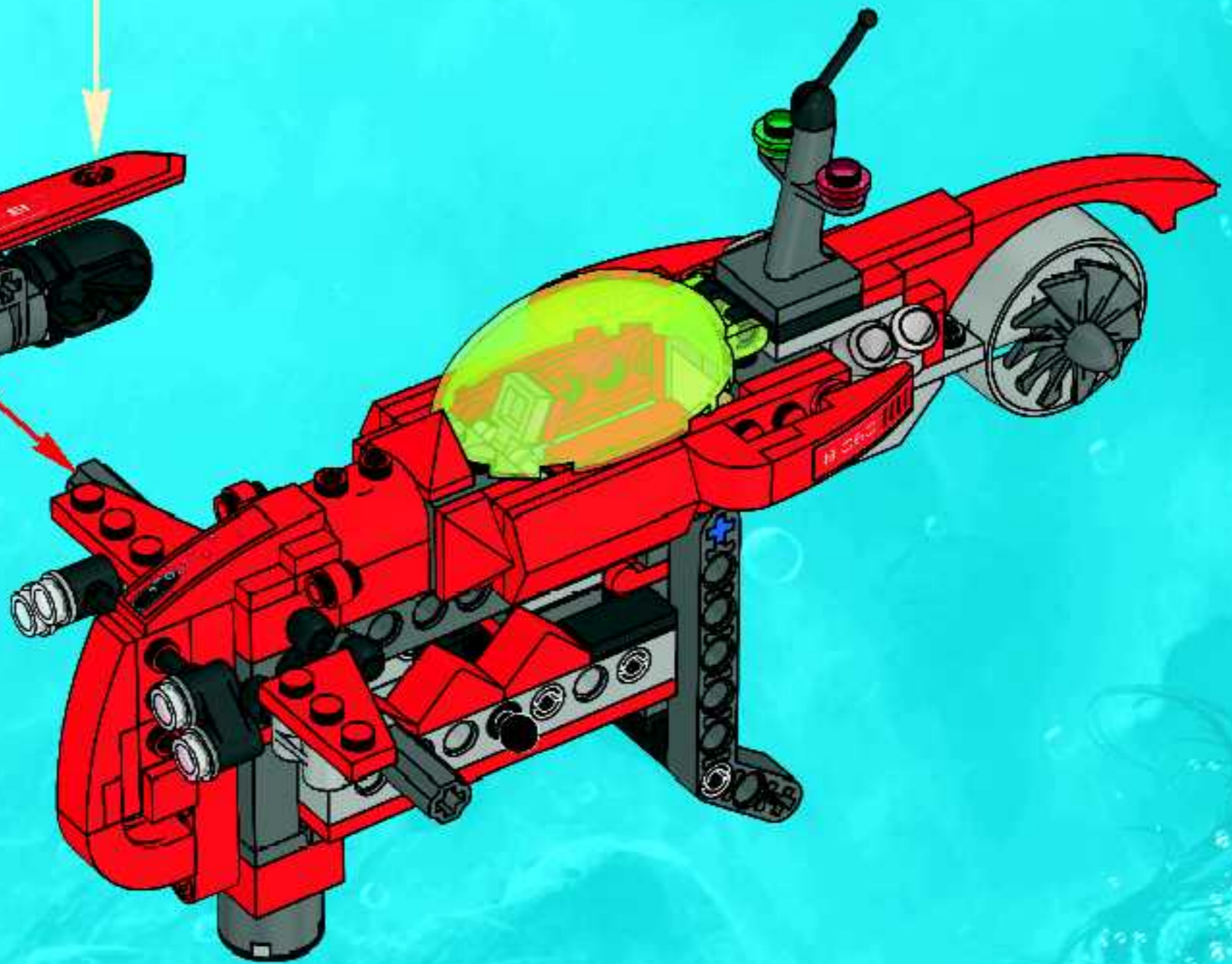
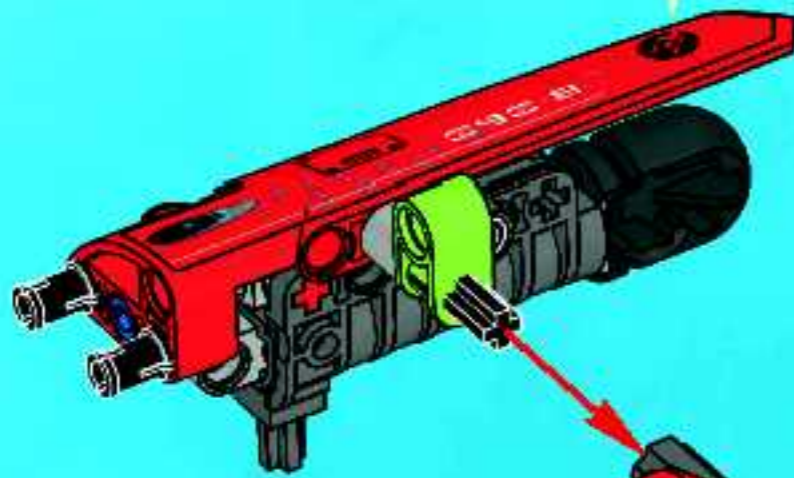



3x

1x

1

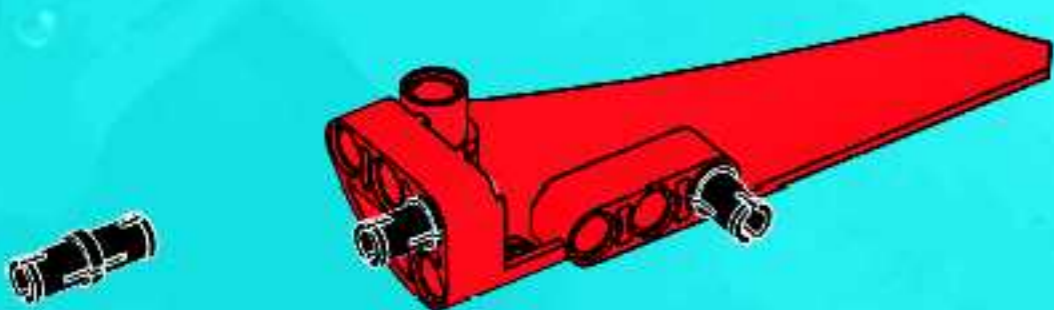

1x

2

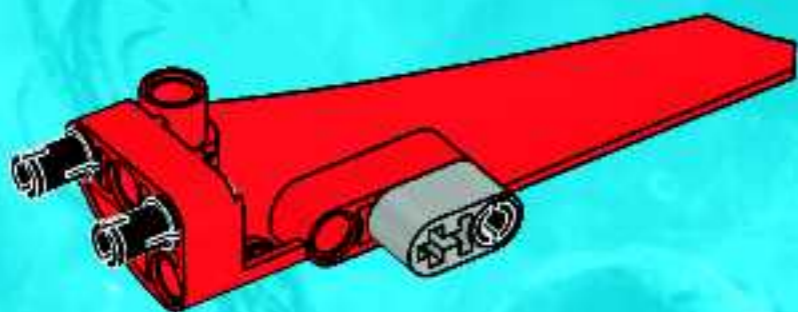

1x

3

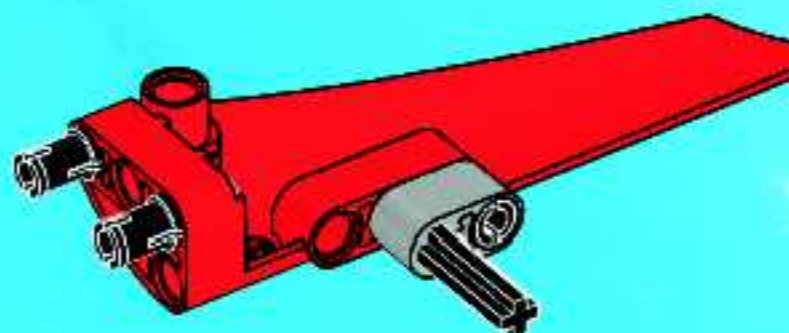

1x

4

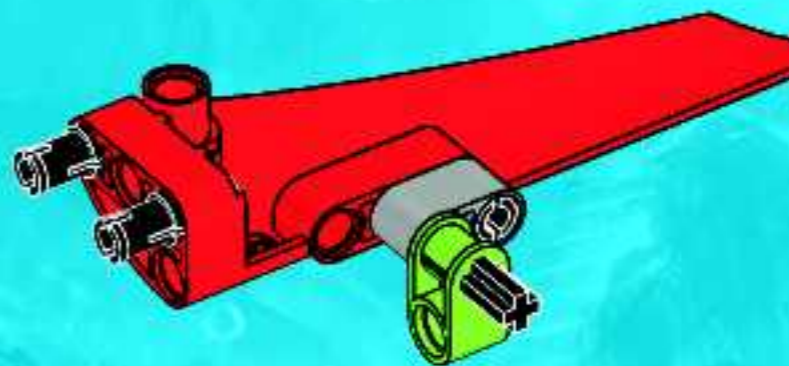

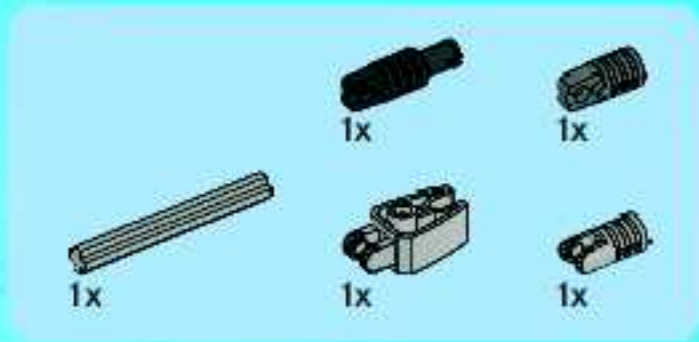

5

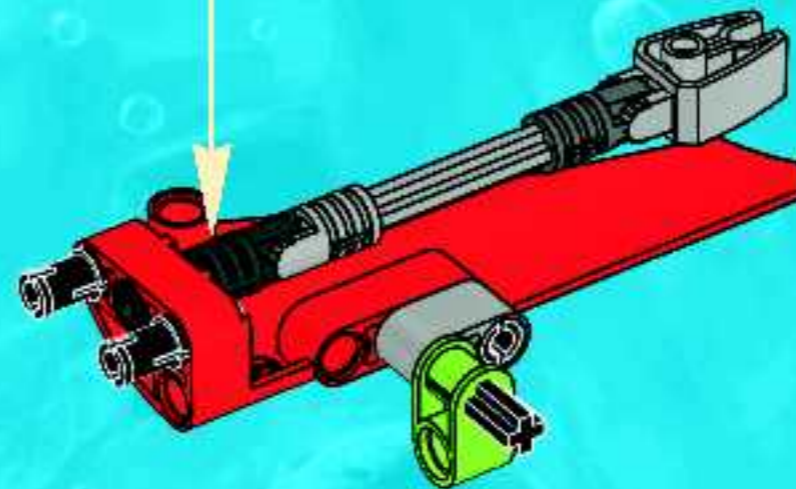
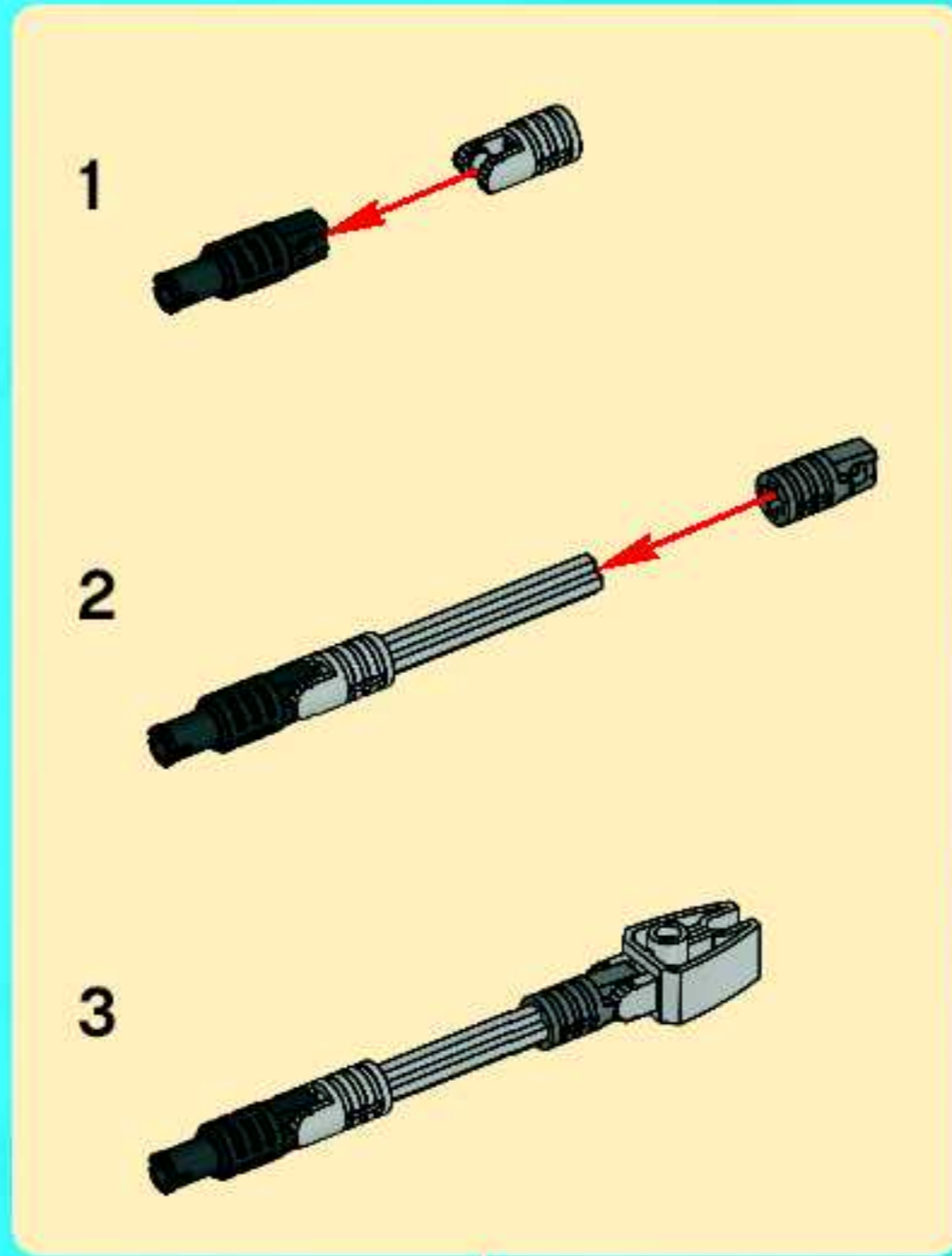

6

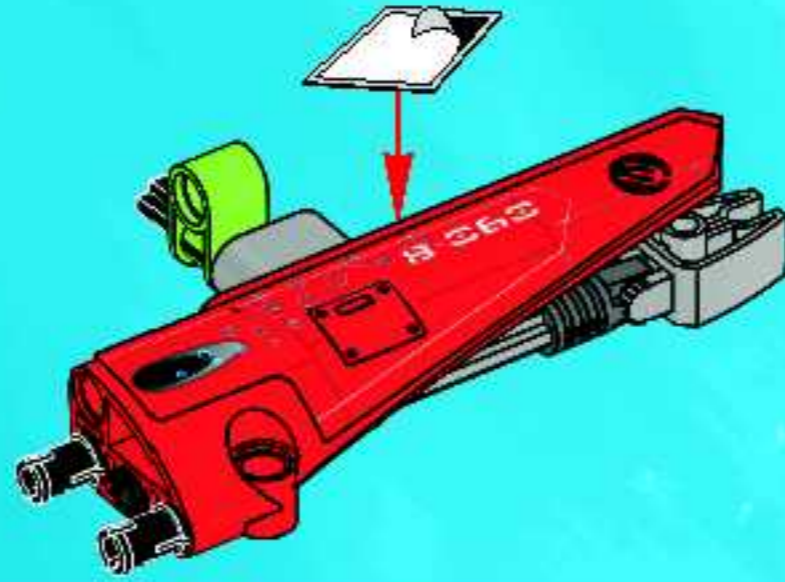

31

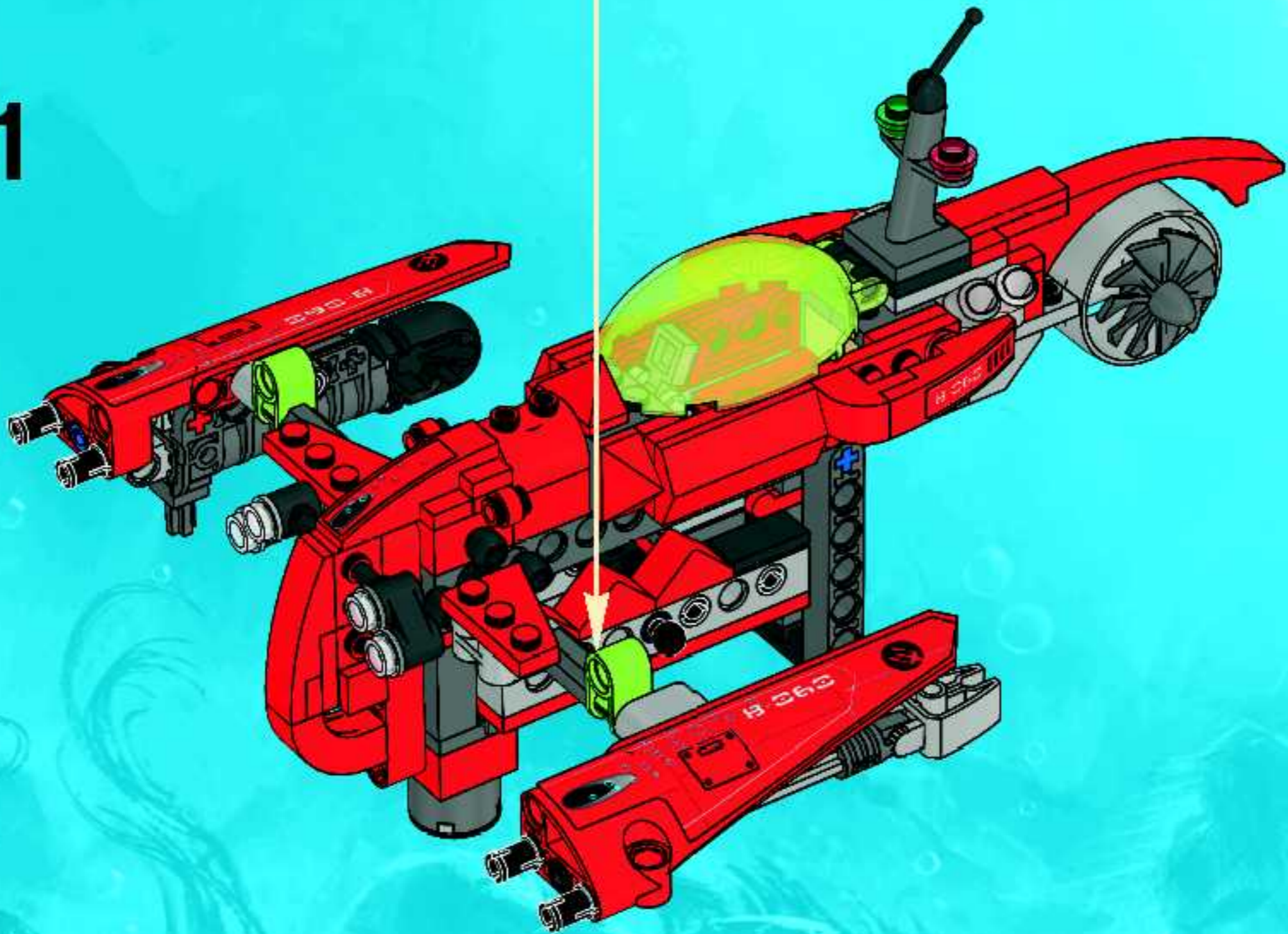

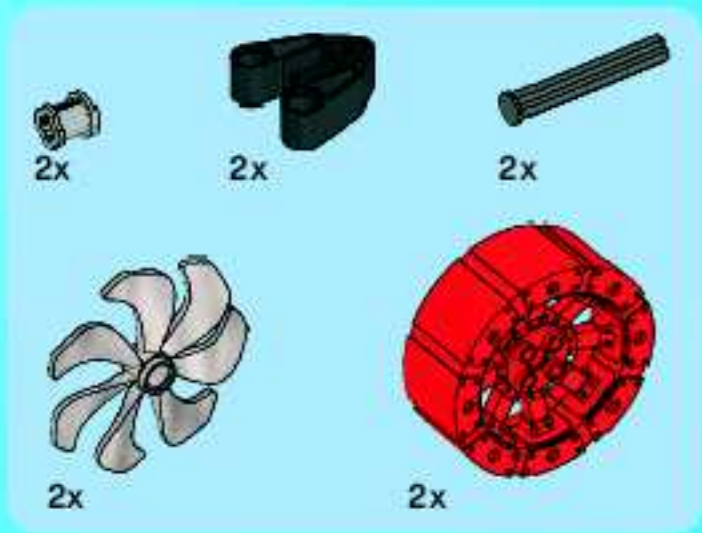

32

1



2



3

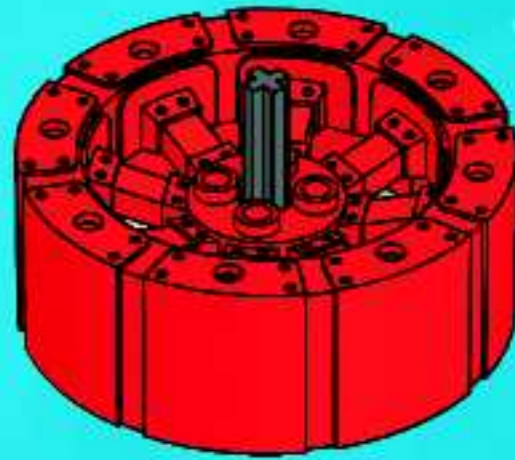

4

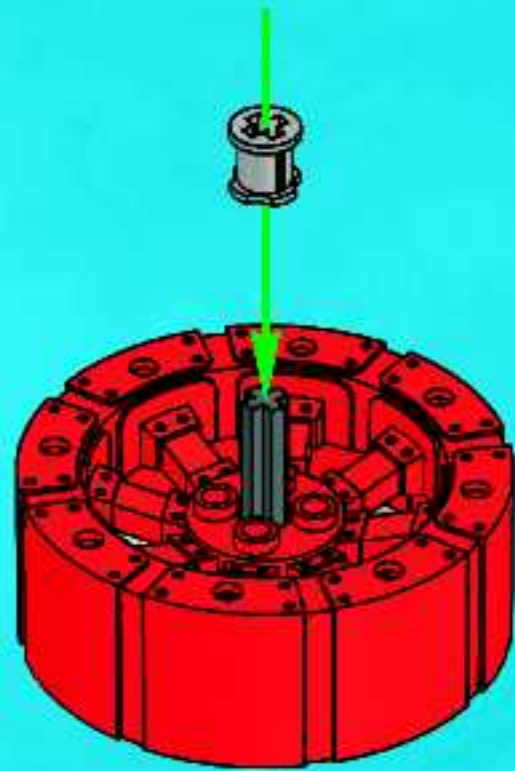

5

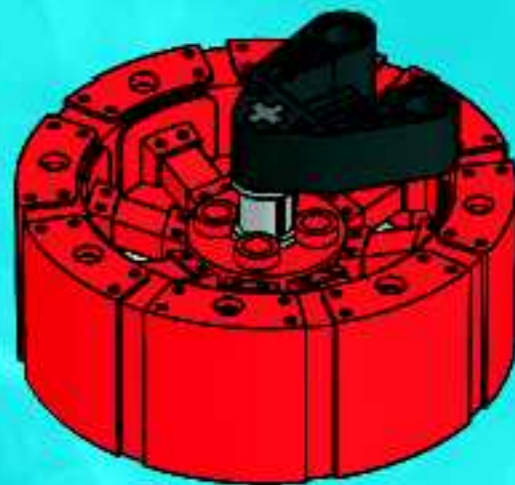

2x

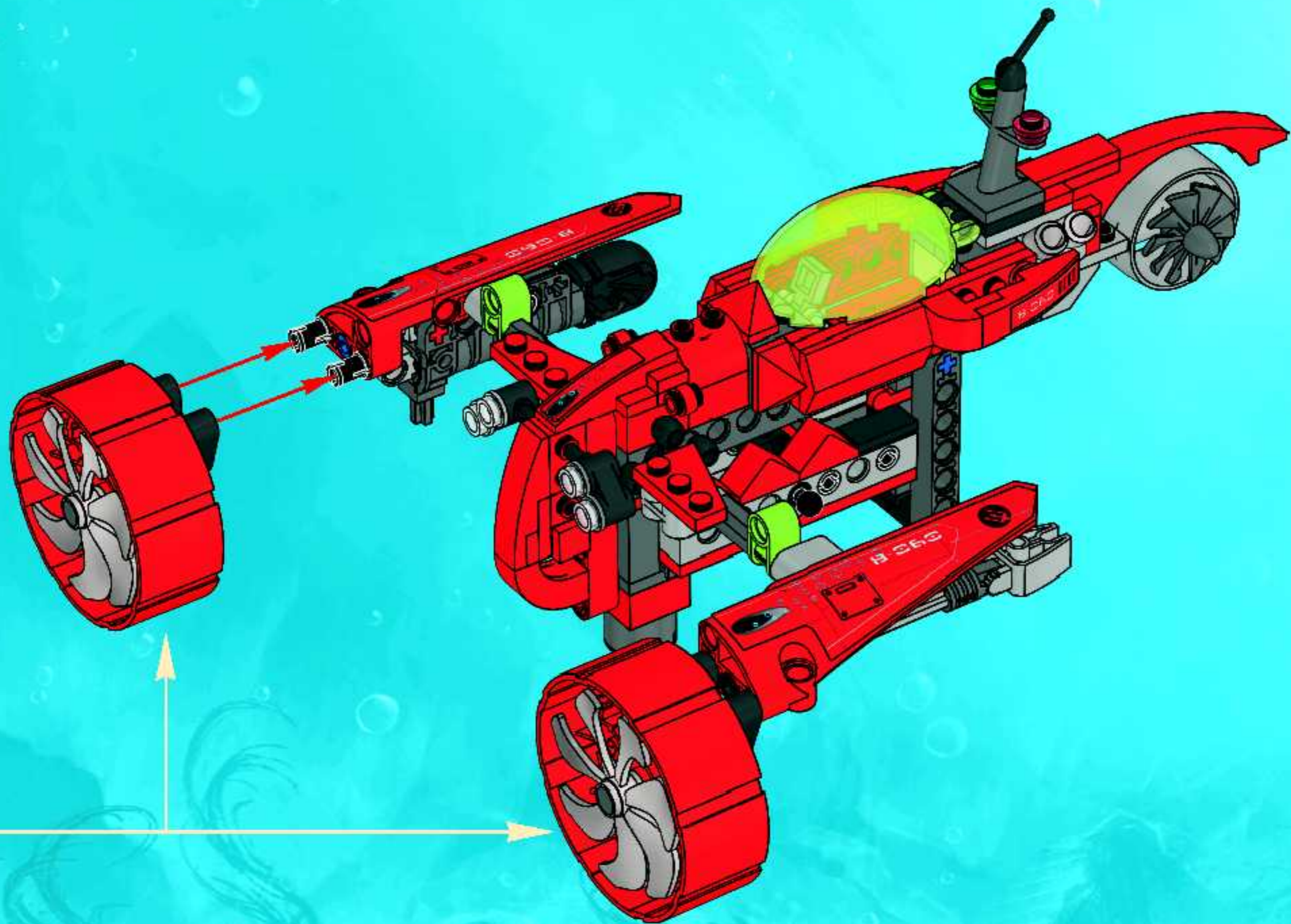



2x



2x

33

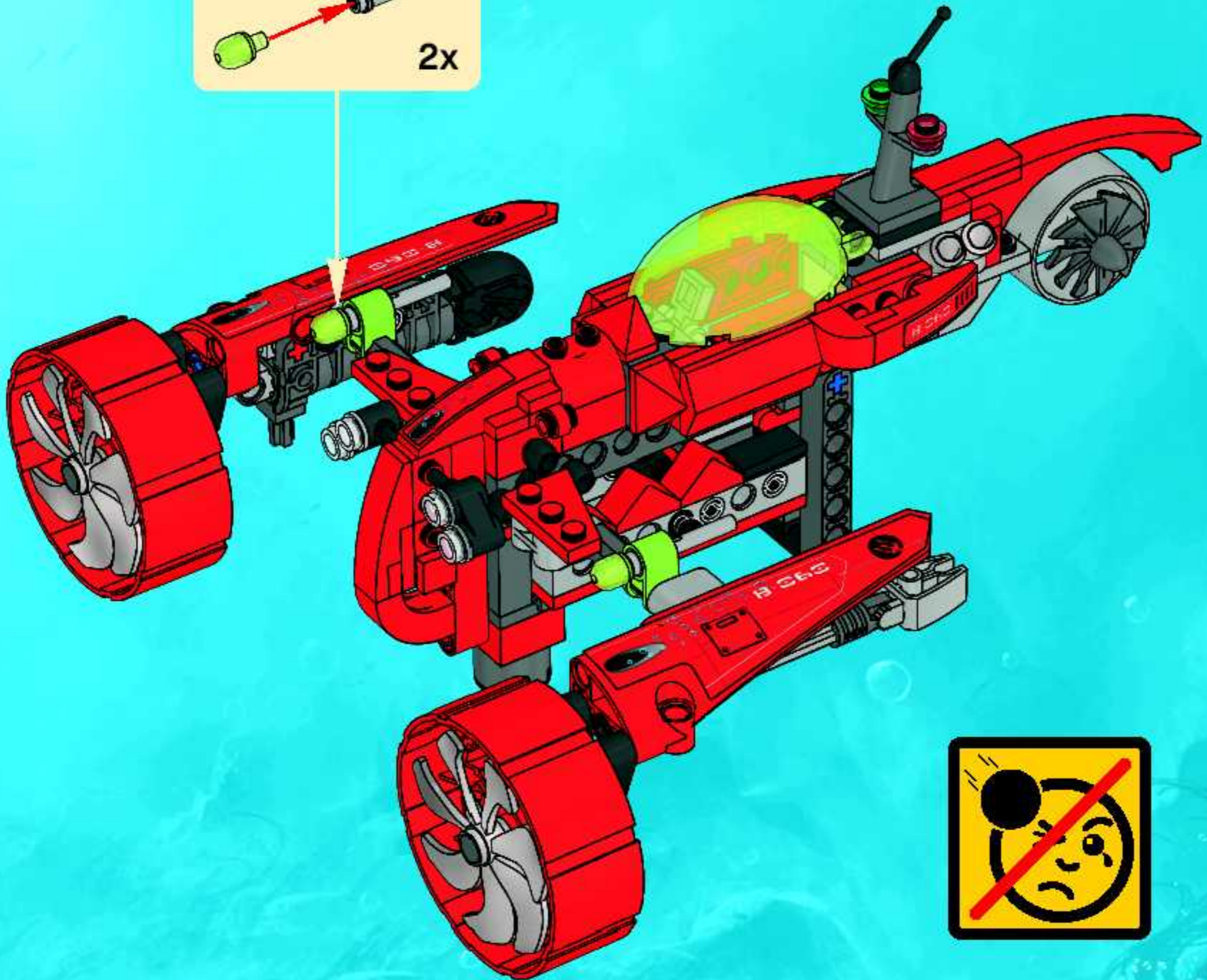
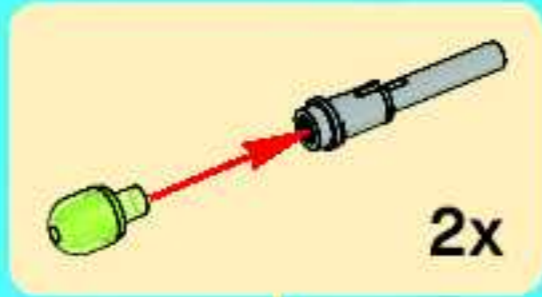

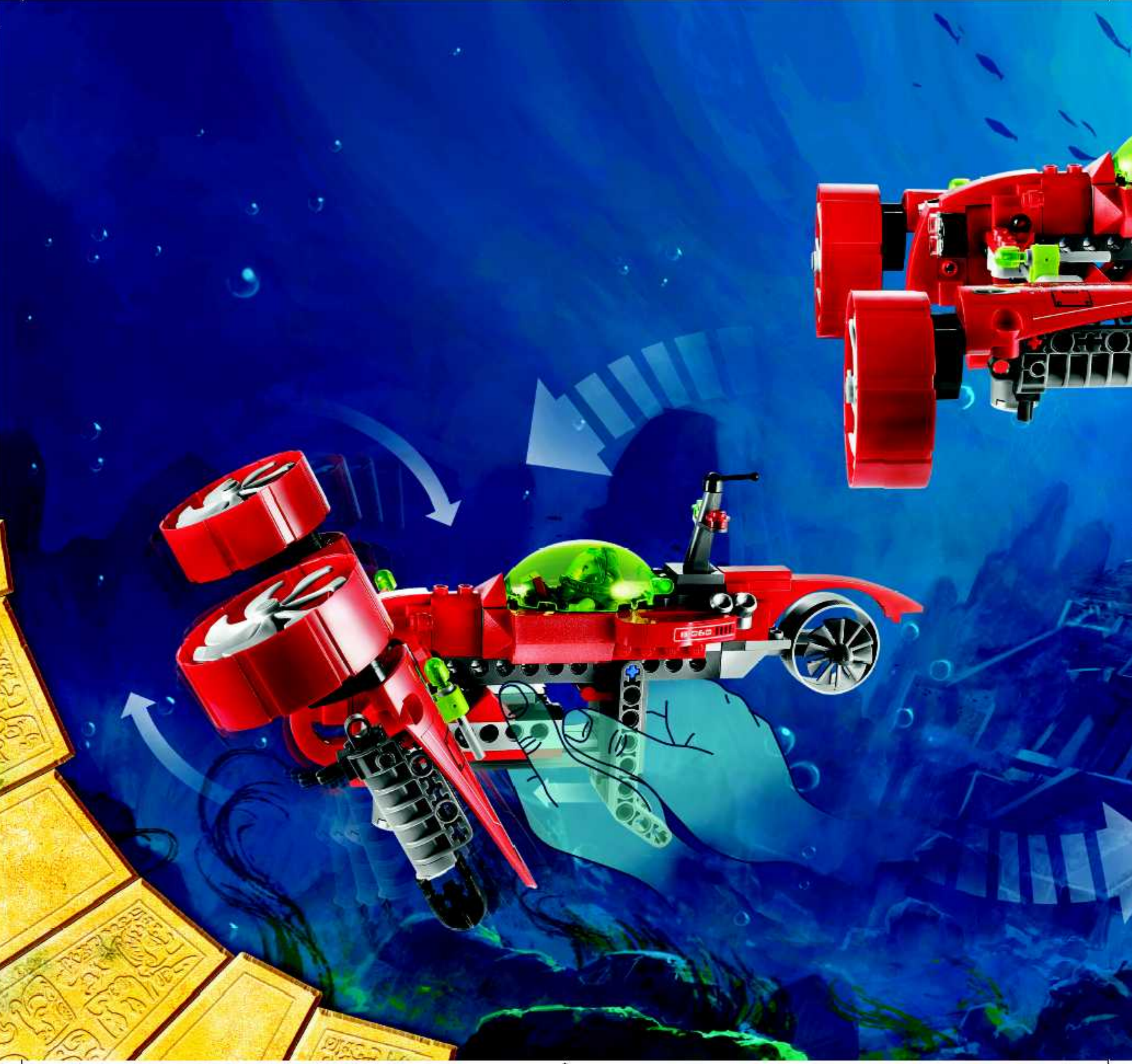



8060



8061



8075





8056



8057



8058



8059





ATLANTIS

8056



8058

8057



8059



8061



8075





ATLANTIS

MAP OF ATLANTIS

LO 230:23.5
LA 40:22.7
ETA 02:43:00

SIM 440:00.5
IN 10:11.1
OUT 30:33.33



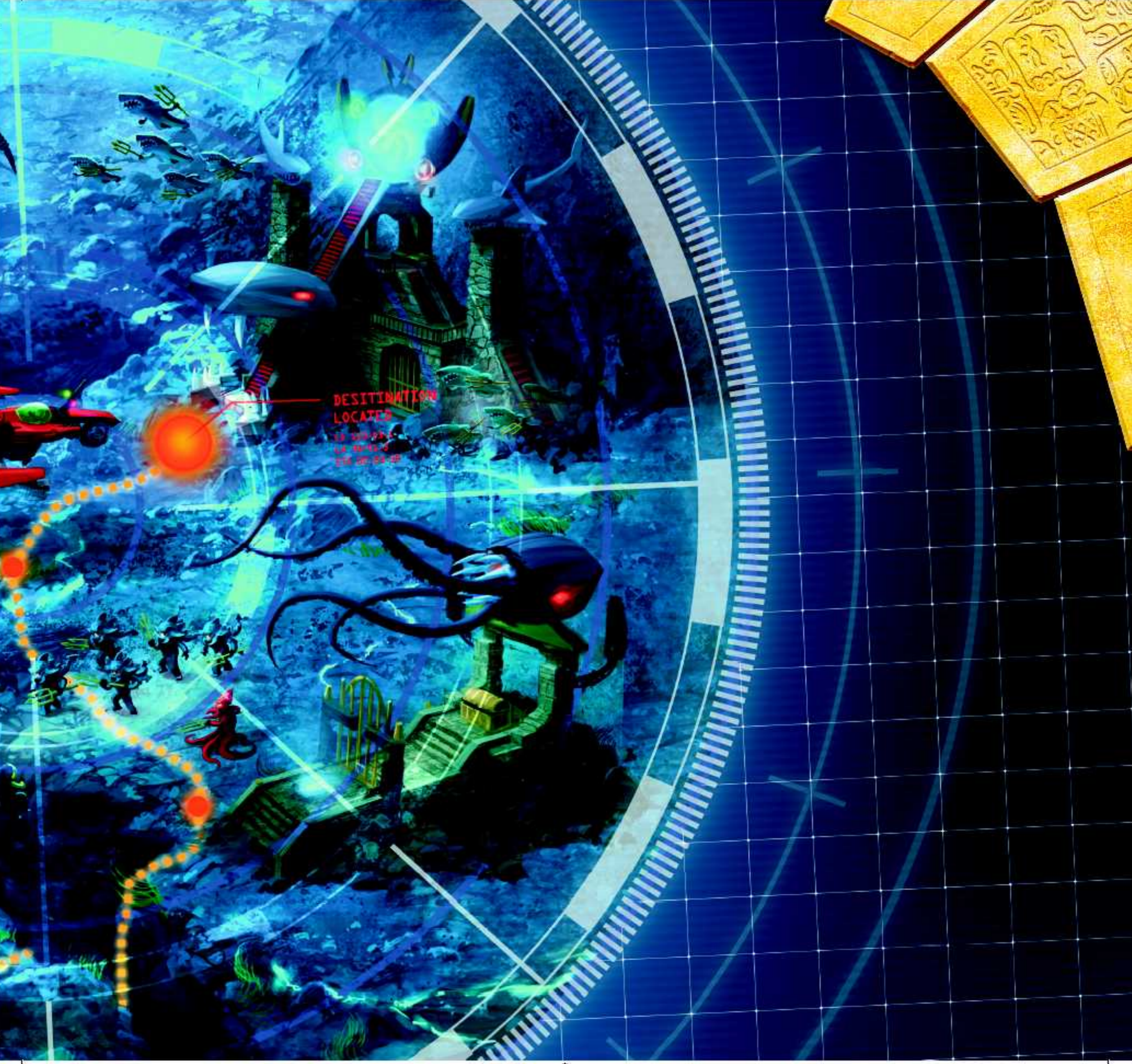



ATLANTIS.LEGO.COM



ATLANTIS



1

atlantis.lego.com/products/8058.aspx



FREE! GRATIS! GRATUIT!



www.LEGOclub.com



00800 5346 5555*        

  1-866-534-6258 • 1-877-518-5346

US & Canada only

Canada seulement



VISIT THE WORLD'S
BIGGEST LEGO® SHOP!

www.LEGOshop.com

* Freephone. Mobile charges may apply. * Numéro sans frais. Les frais peuvent s'appliquer avec les téléphones cellulaires. * Gebührenfrei. Kosten für Anrufe aus Mobilfunknetzen können anfallen.
* gratis telefoonsnummer via vaste lijn. * Teleszifra gratis numere, nar iz ringer Pro Postbeta Pot. * De lije gratis, nar du ringer från en Postbeta Pot.

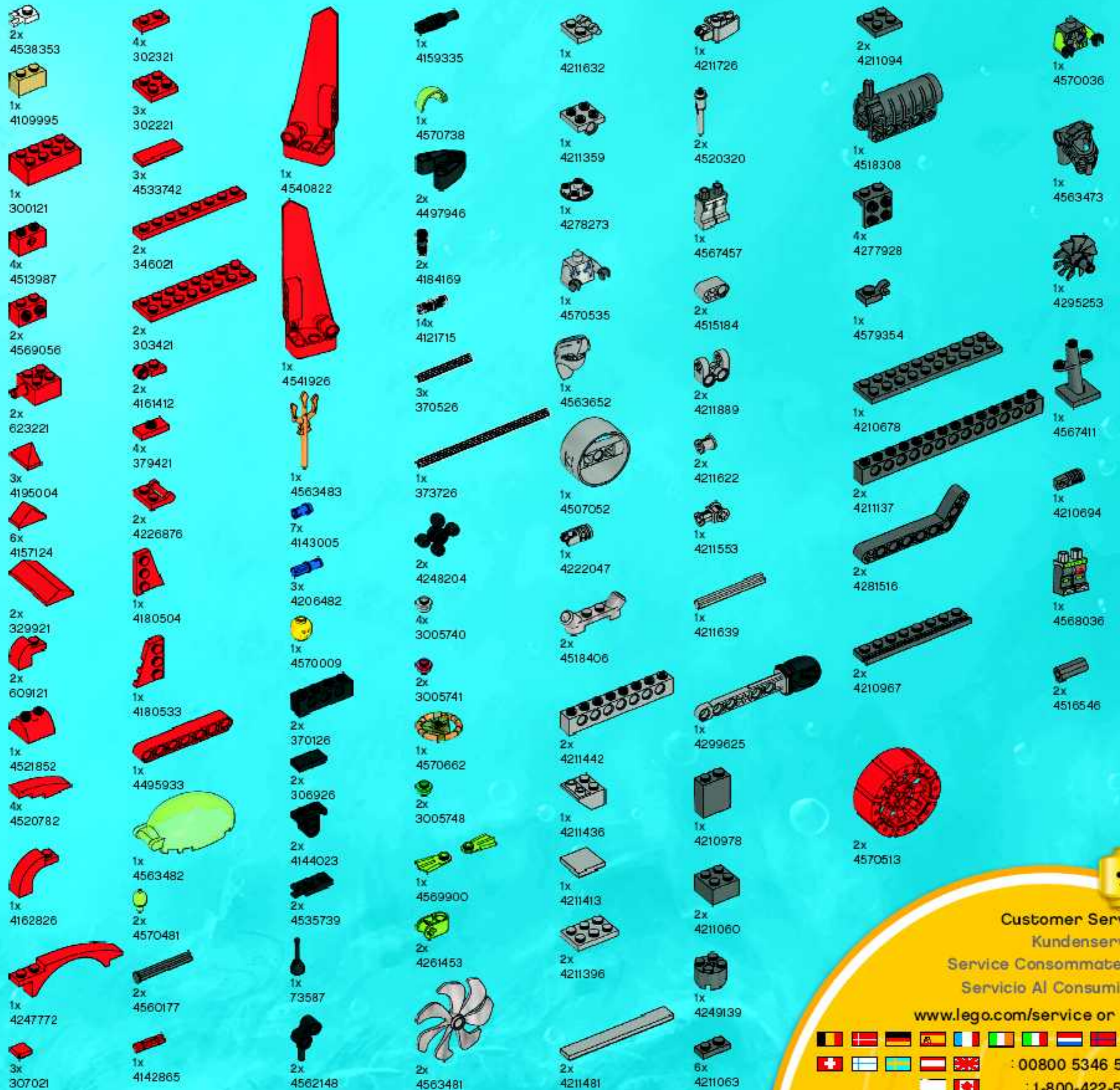

Customer Service
 Kundenservice
 Service Consommateurs
 Servicio Al Consumidor

www.lego.com/service or dial



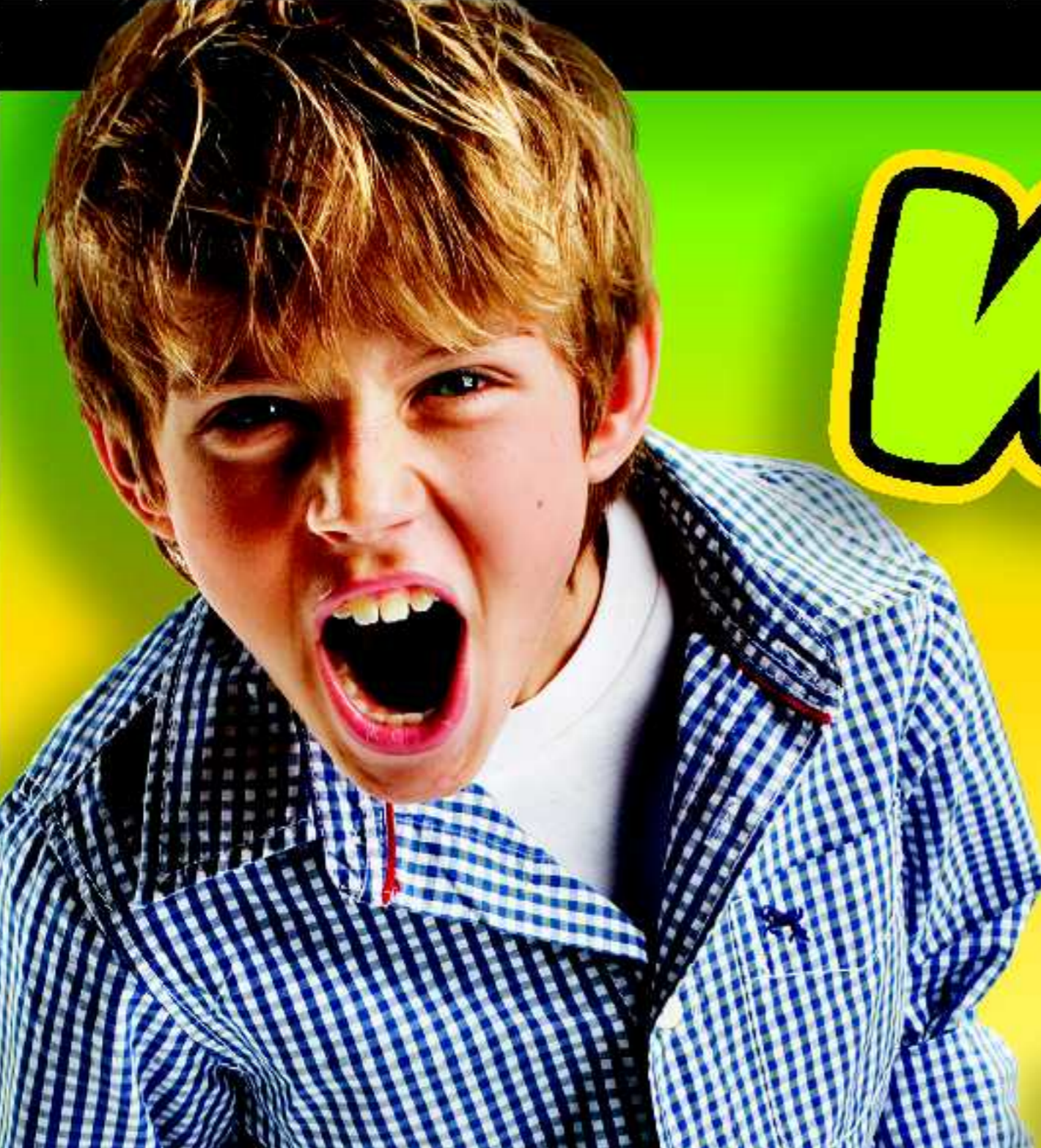

WIN!

Go to www.nielsen.com/LEGO
to fill out a survey for a chance
to win a cool LEGO® Product.
No purchase necessary.
Open to all residents where not prohibited.

 www.LEGO.com



www.nielsen.com/LEGO

GEWINNE! WIN!

Nimm an der Umfrage auf
www.nielsen.com/
LEGO teil und hab die Chance ein cooles
LEGO® Produkt zu gewinnen!

Die Teilnahme am Gewinnspiel führt zu keinerlei
Kaufverpflichtungen. Teilnahme in allen nicht
ausgeschlossenen Ländern möglich.

Ga naar www.nielsen.com/LEGO,
vul een enquêteformulier in en
maak kans op een
cool LEGO® product.

Geen aankoopverplichting.
Iedereen mag deelnemen, uitgezonderd
ingezonden
van landen waar een enquêteverbod geldt.

GAGNE! 当てよう!

Visite www.nielsen.com/LEGO
pour répondre à un questionnaire
et avoir une chance de gagner
un produit LEGO® très cool!

Aucune obligation d'achat.
Ouvert à tous les résidents des pays
autorisés.

www.nielsen.com/LEGOにアクセスして、アンケ
ートにご記入ください。当選者にはレゴ製品を
差し上げます。

お買い上げの必要はありません。
禁止されていない限り、すべての店舗にご利用いただけます。