



# CITY

4433



1

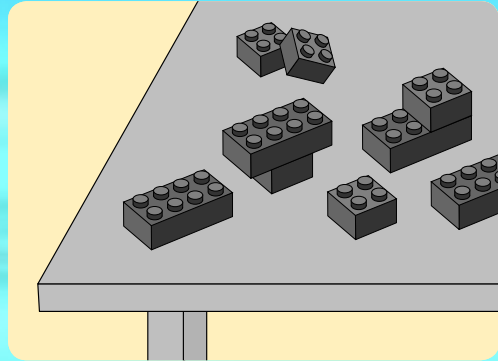
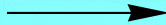
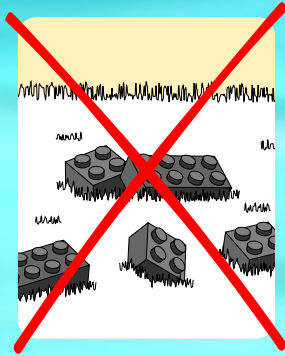

2

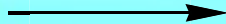

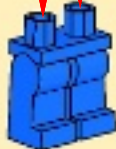
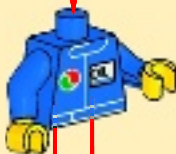



1

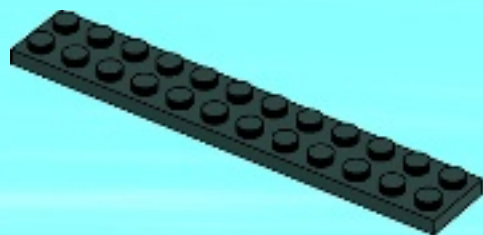

2

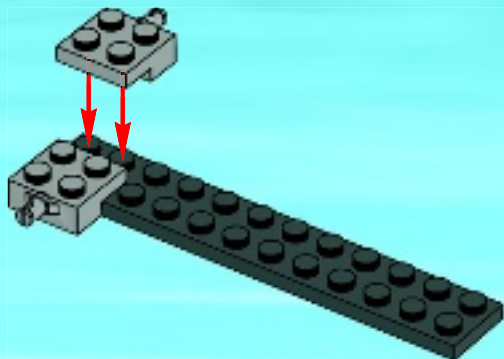

3

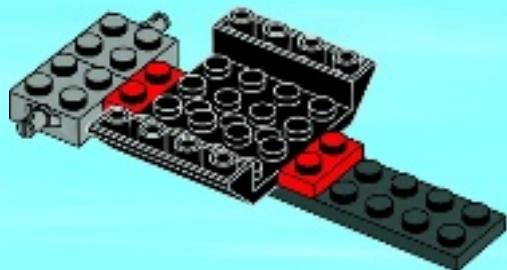

4



5

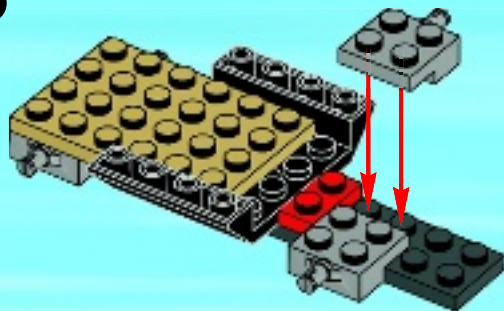

6

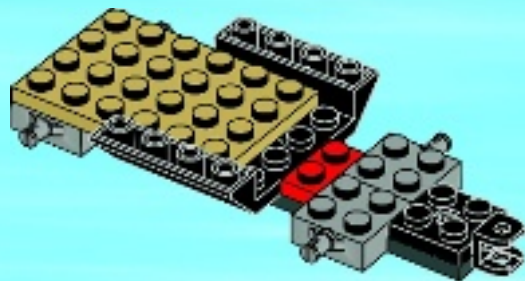

7

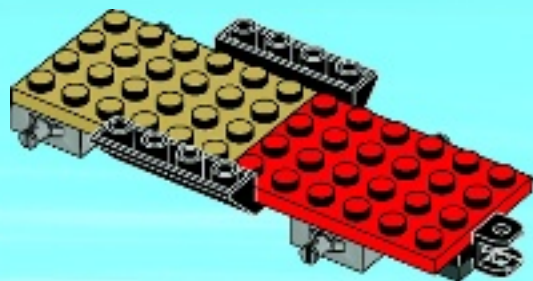



8

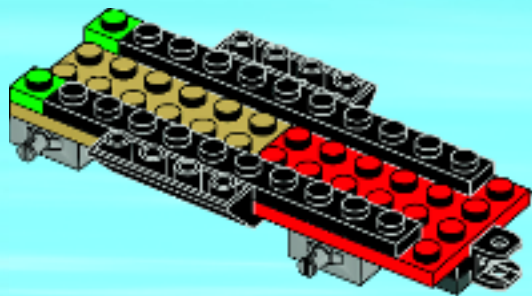

9

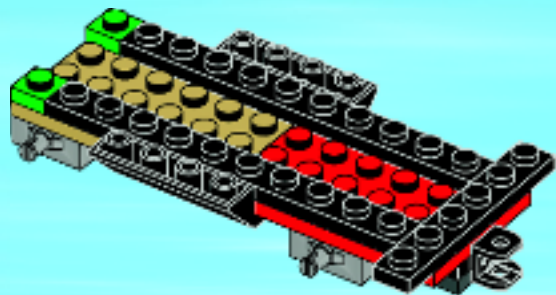

10

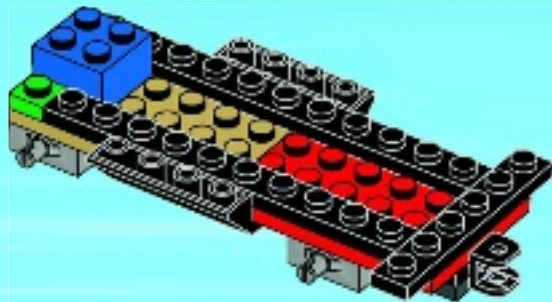

11

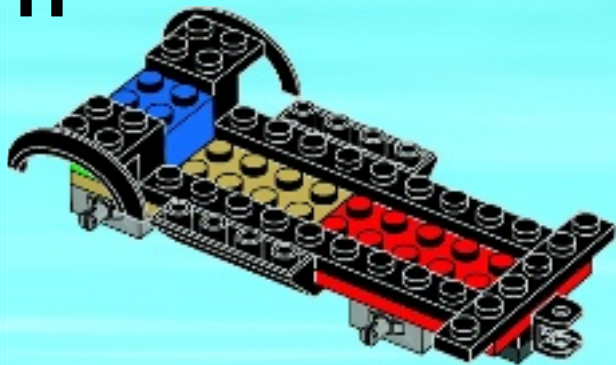

12

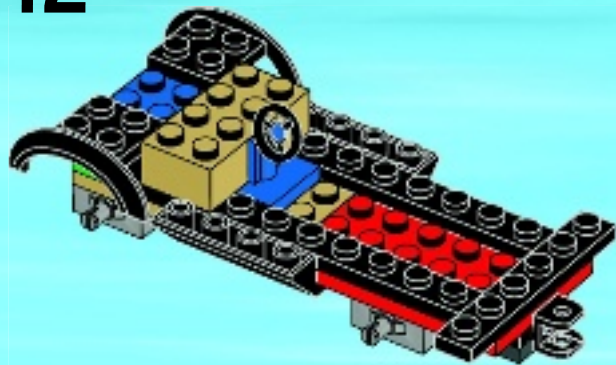

13

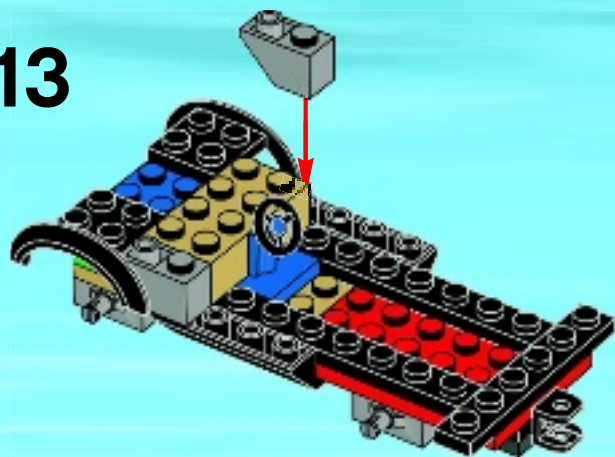

14

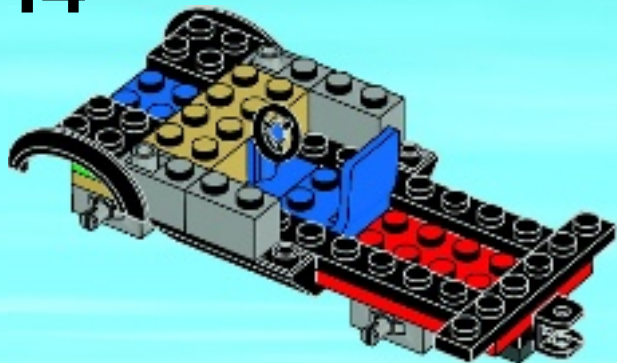

15

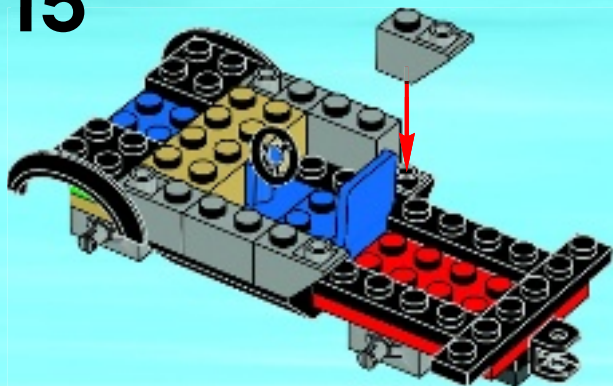

16

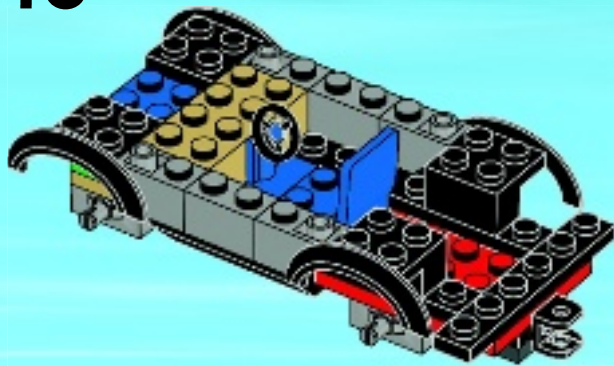

17

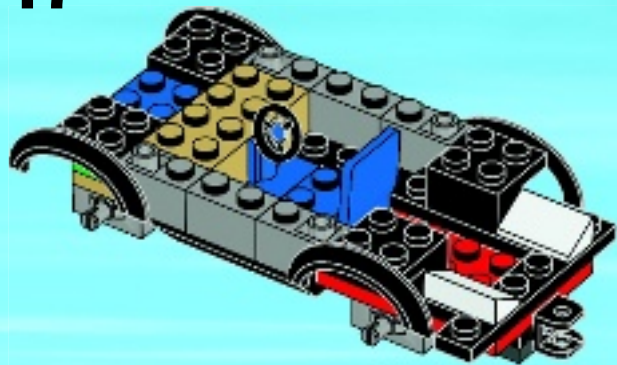

18

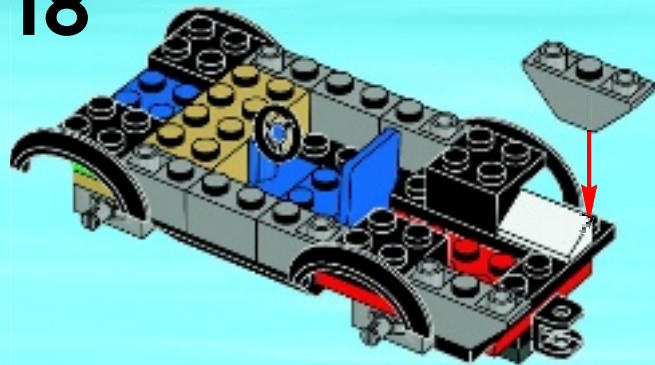

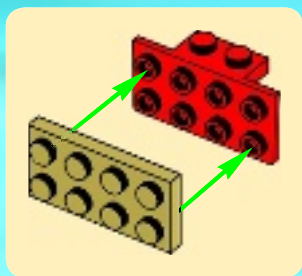

19

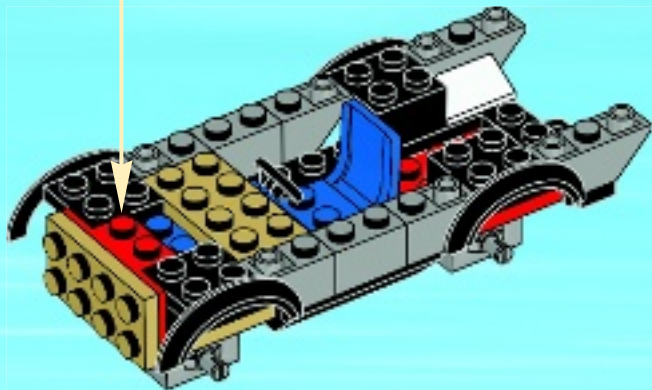



20

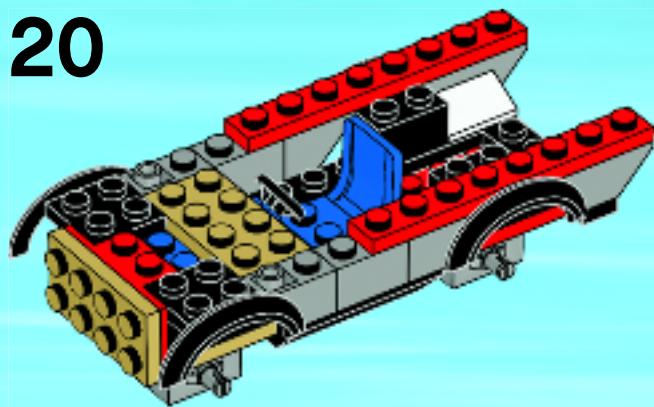

21

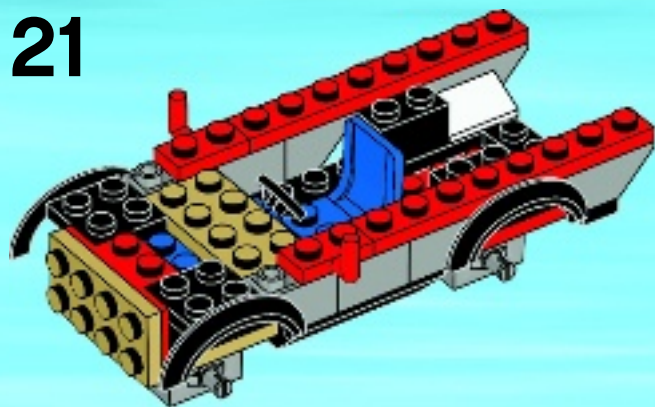

22

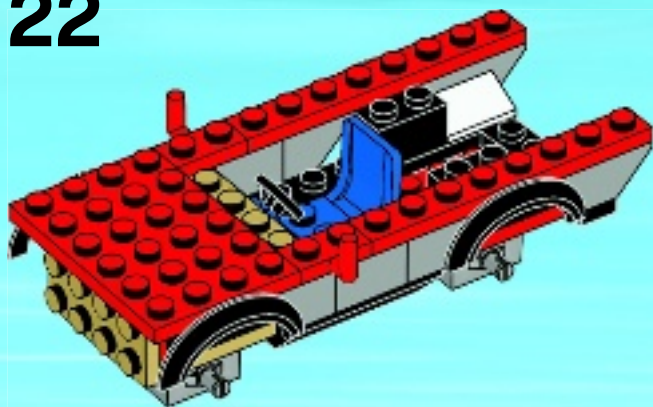



1

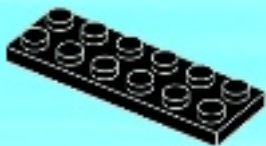

2

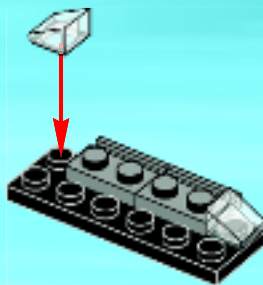

3

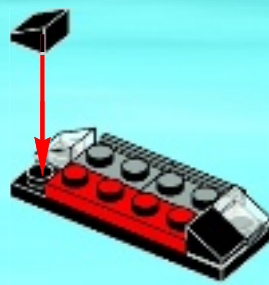

4

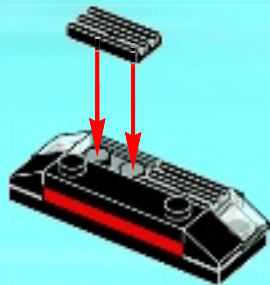

5



6

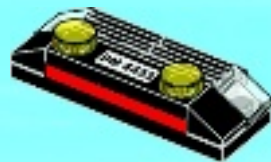

23

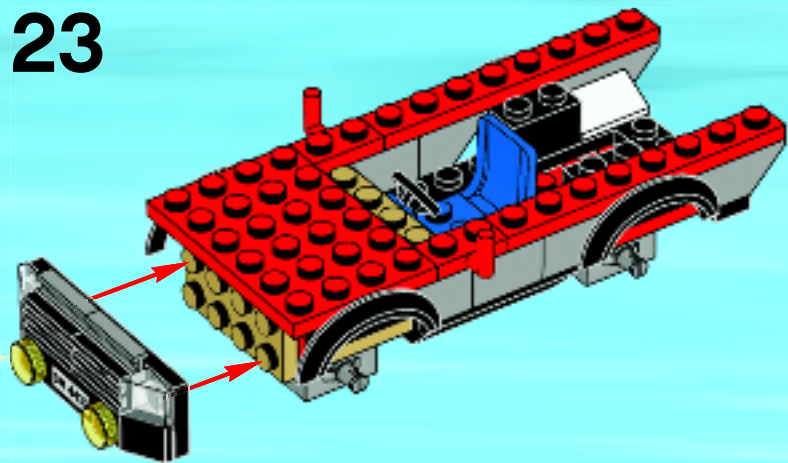

24

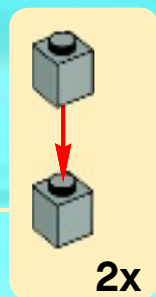
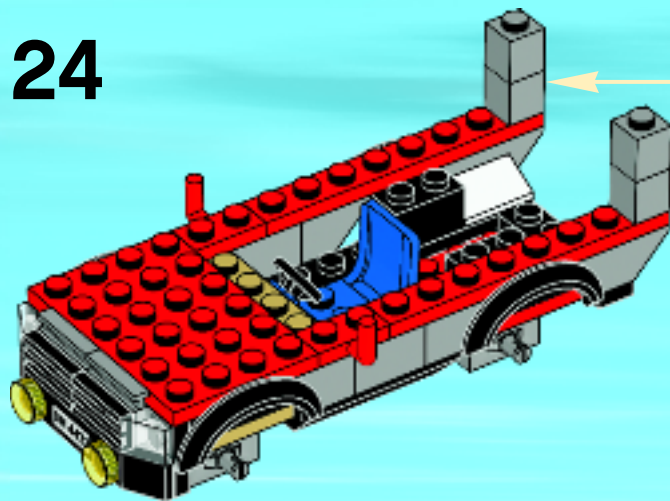

25

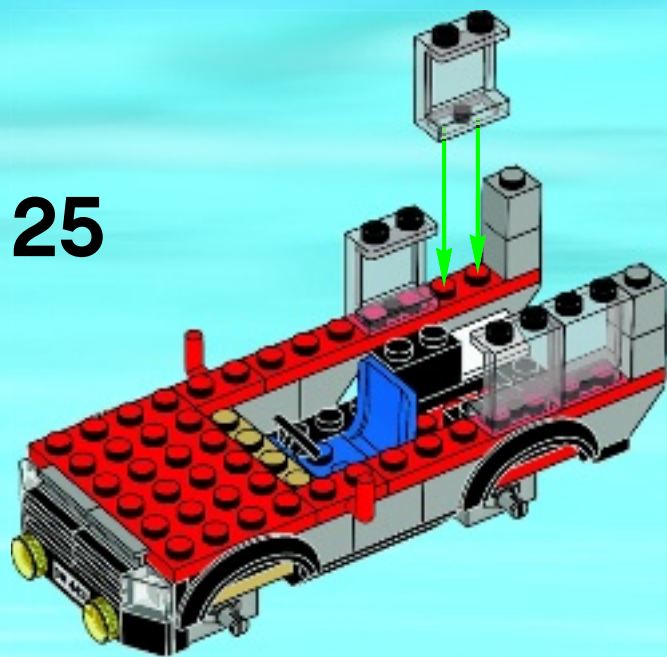

26

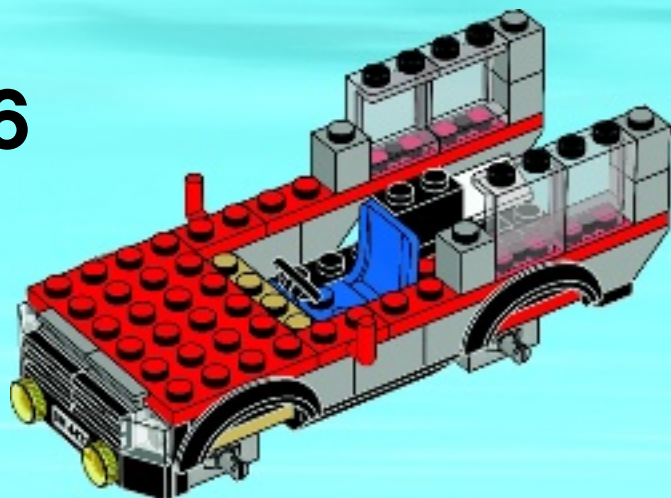



27

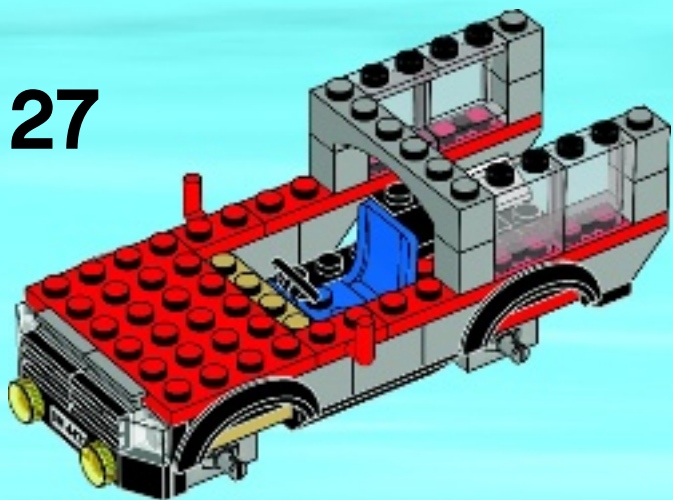

28

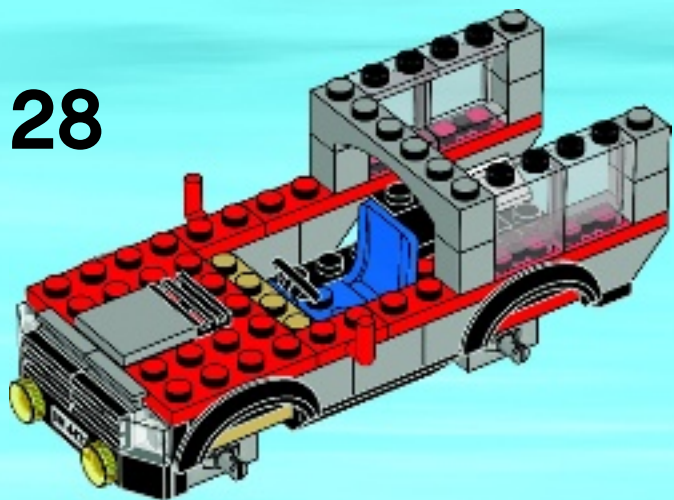

29

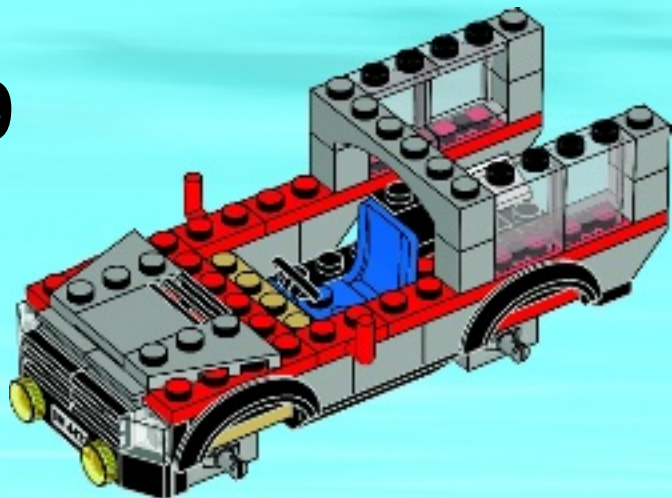

30

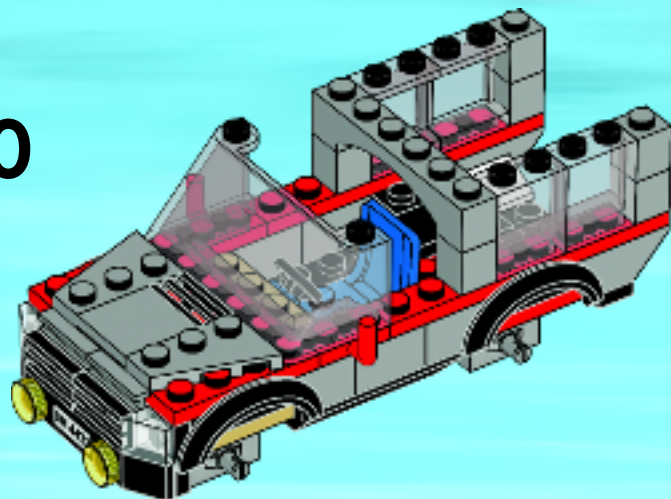

31

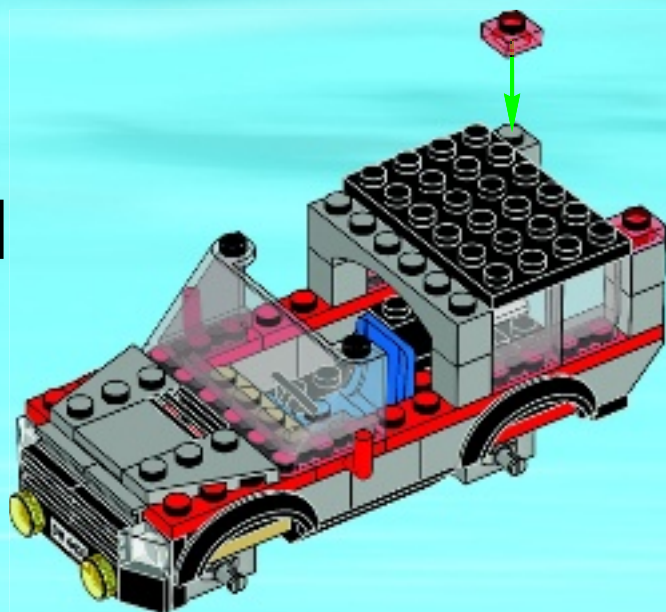

32

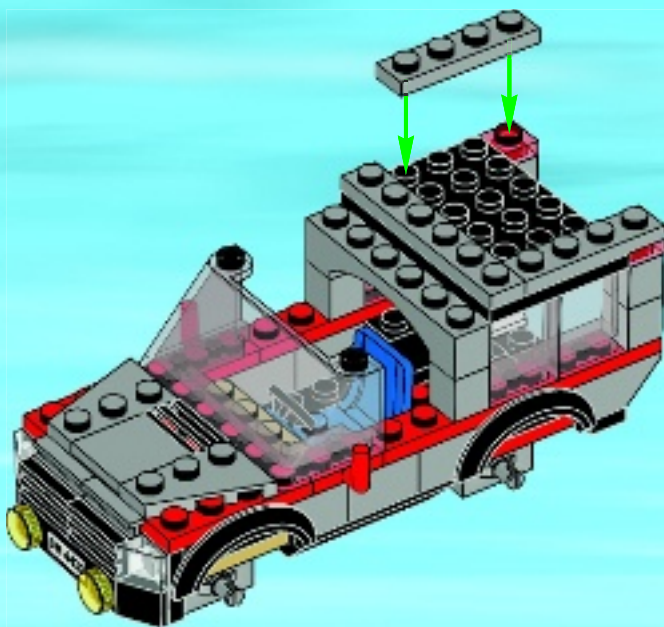

33

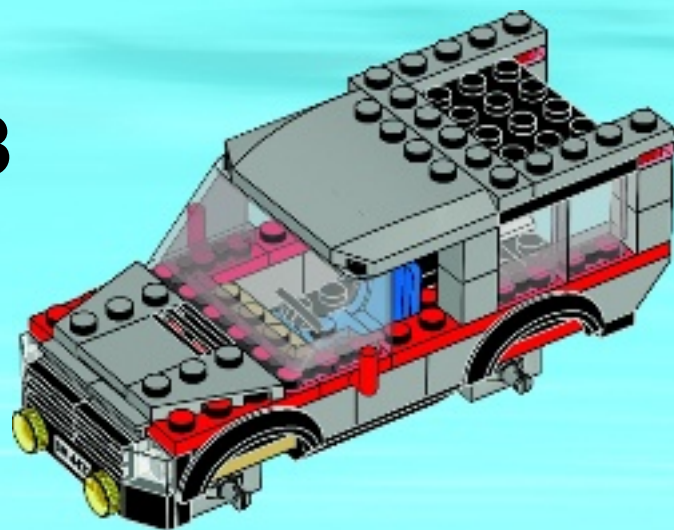

34

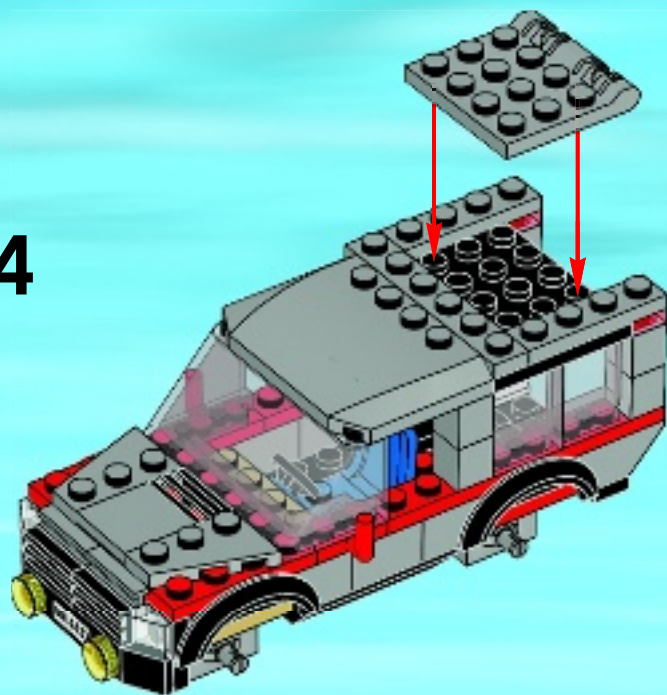

35

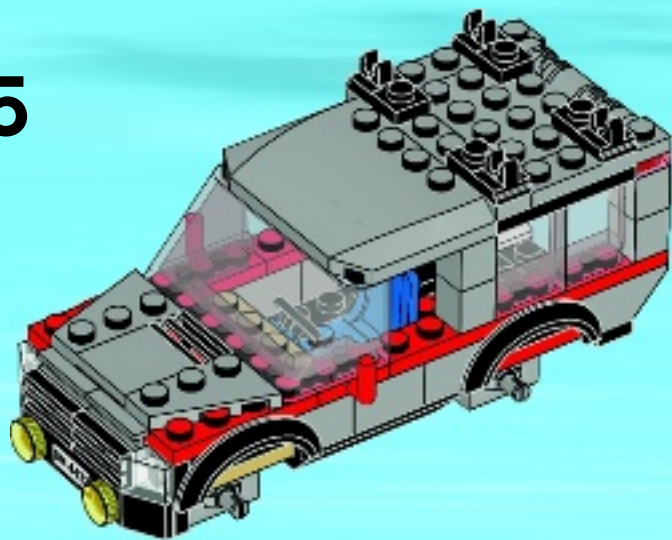



36

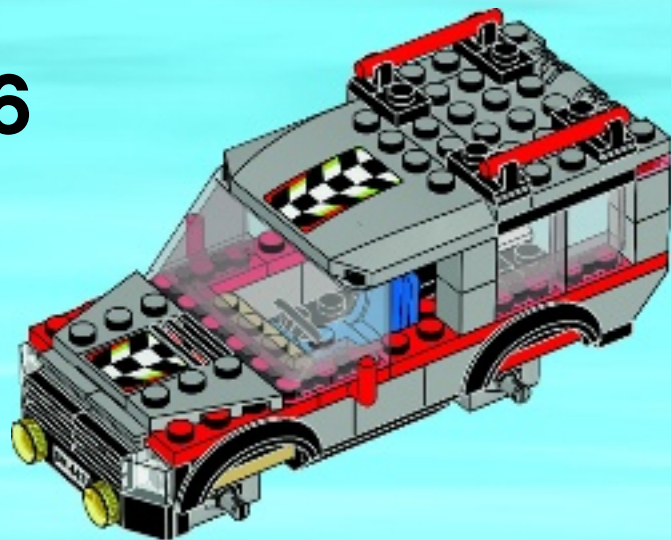

37

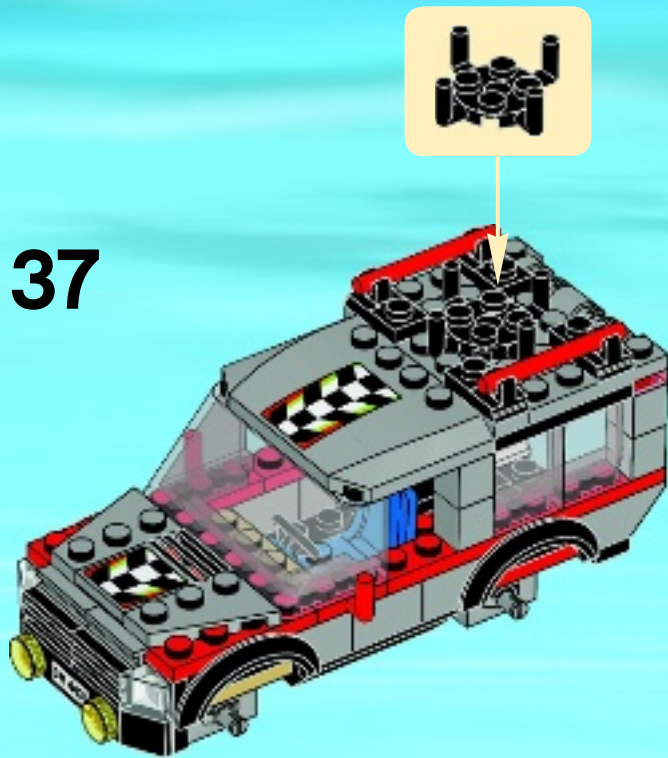

38

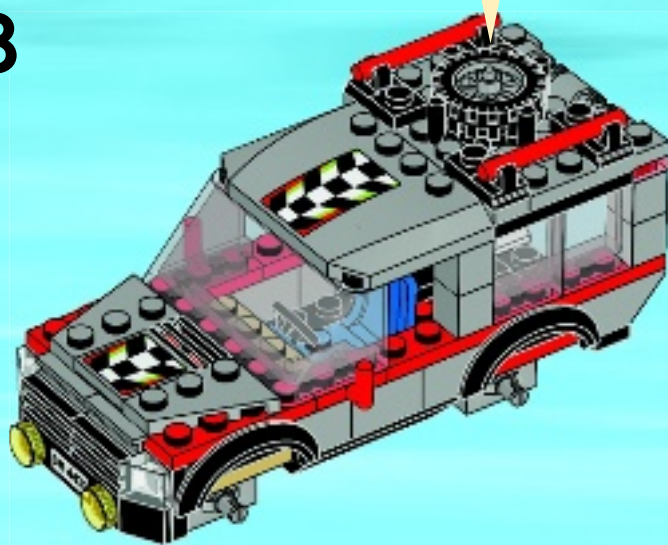

1



2



39

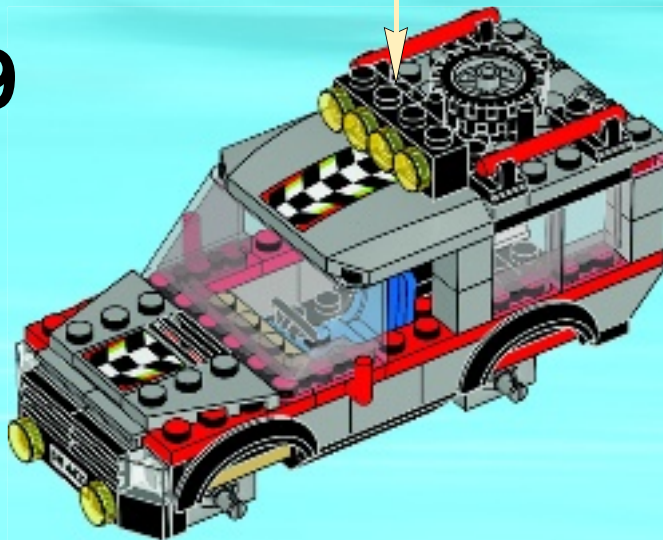



**1**

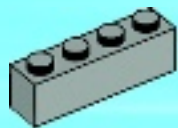

**2**



**3**



40

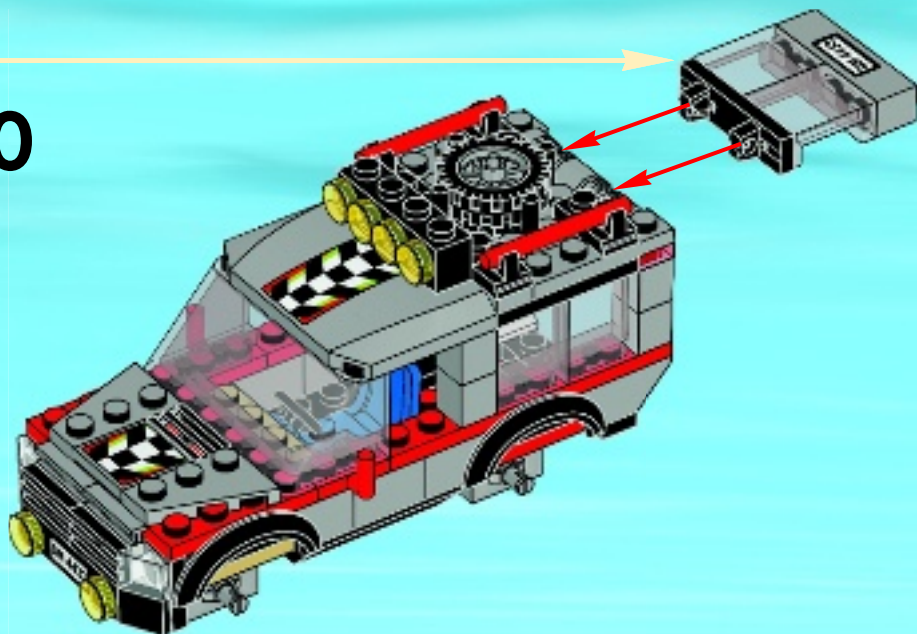

41

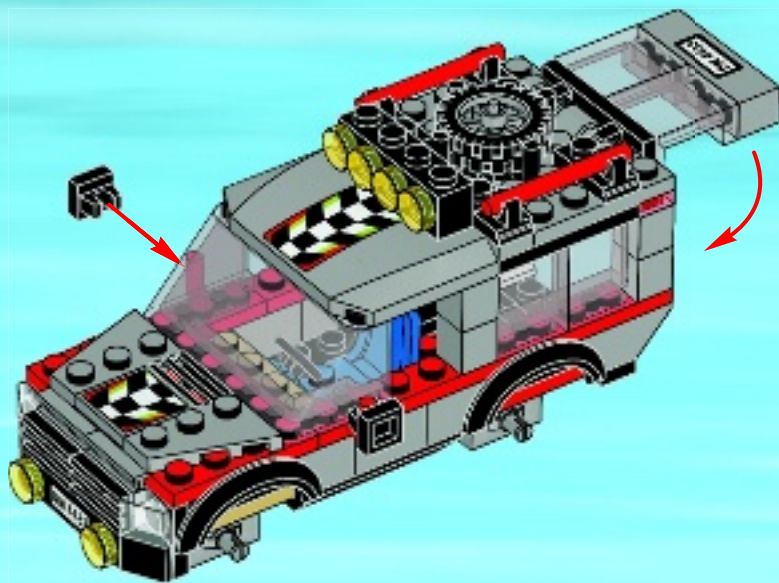

42

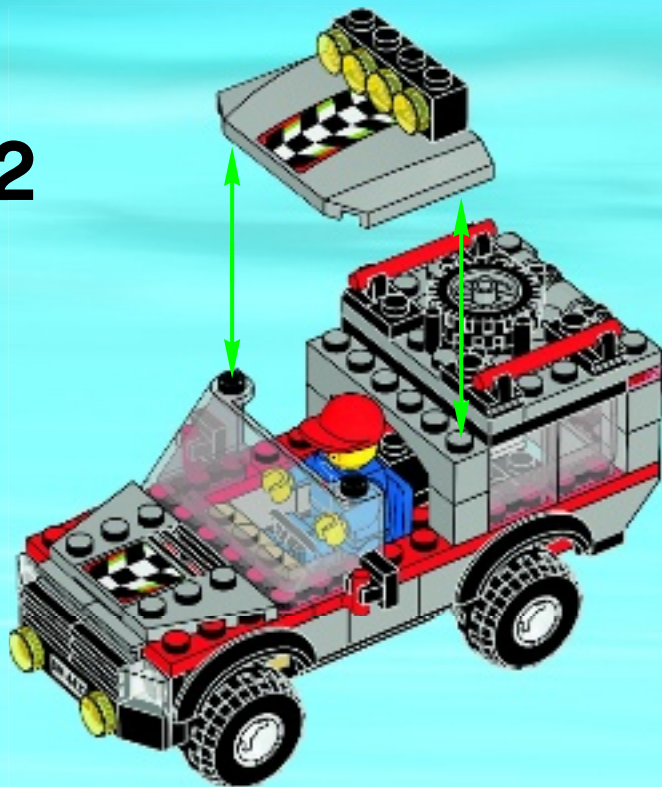





# CITY

4433



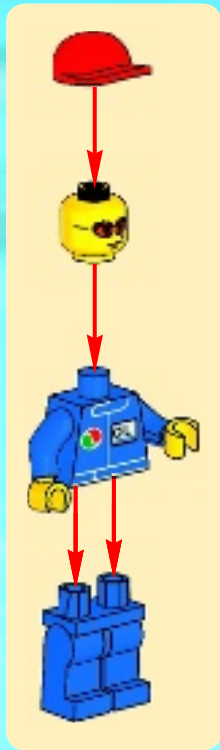
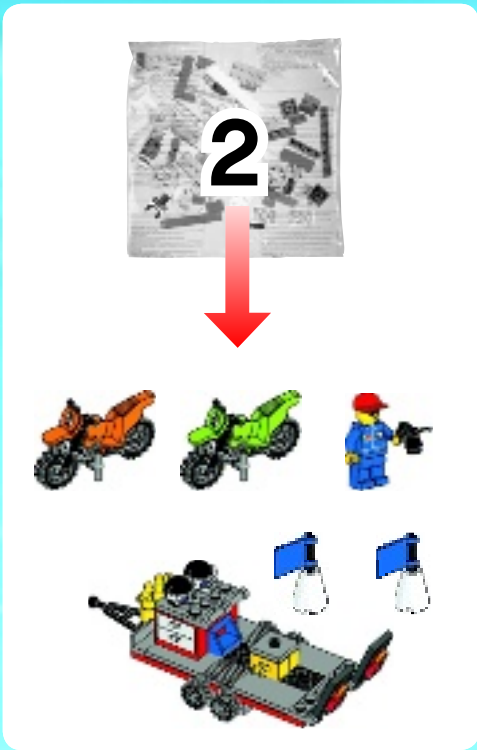

1

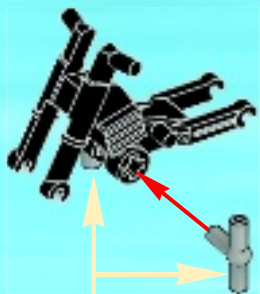

2



3



1

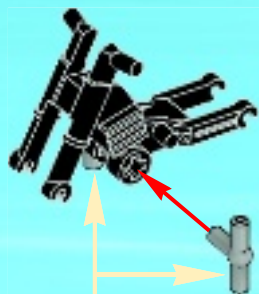

2x

2



3





1



2

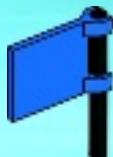

3



2x

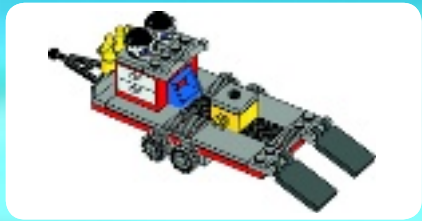

1

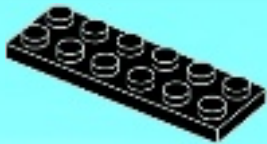

2

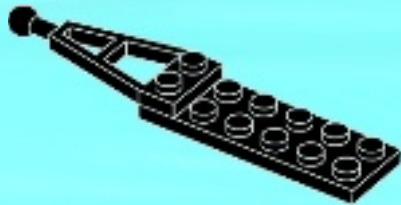

3

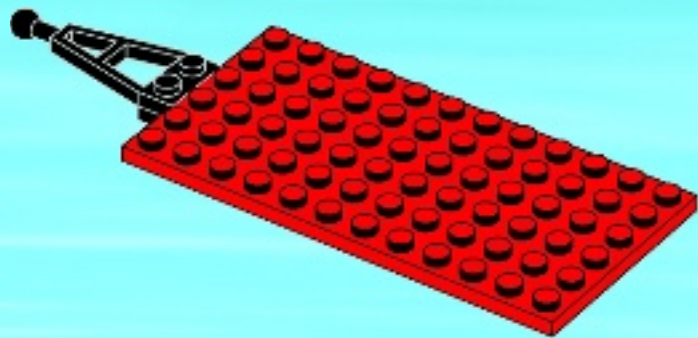

4

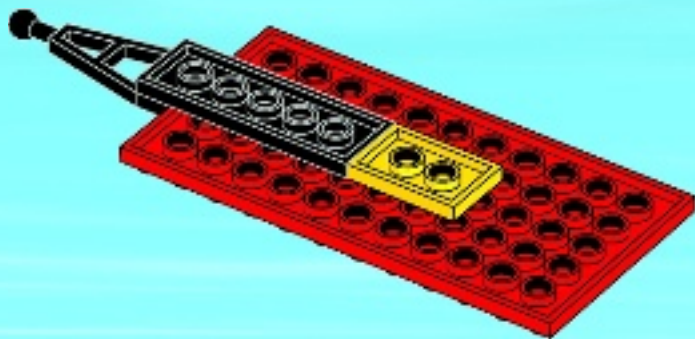



5

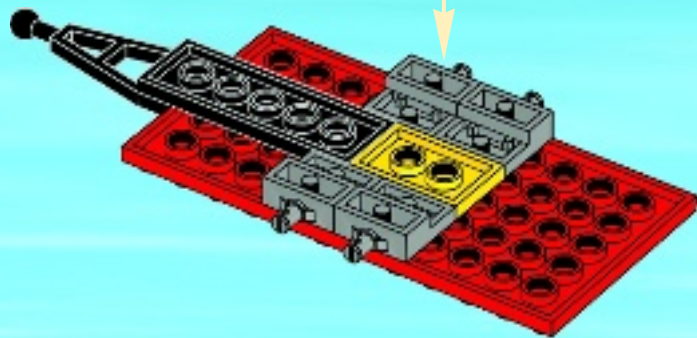

4x

6

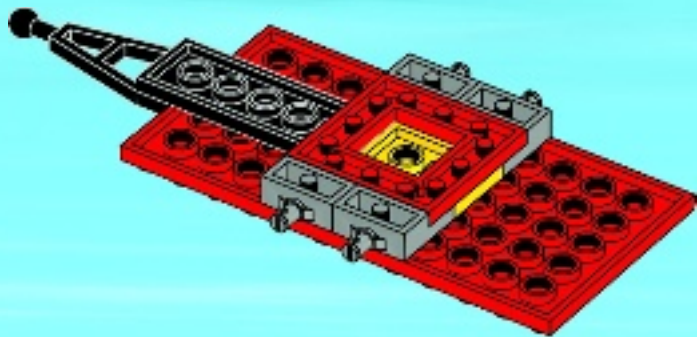

7



8

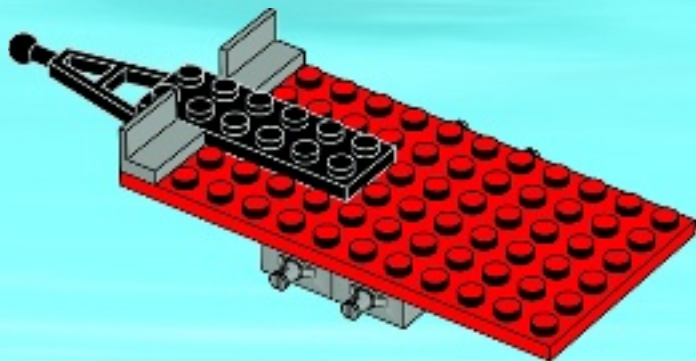

9

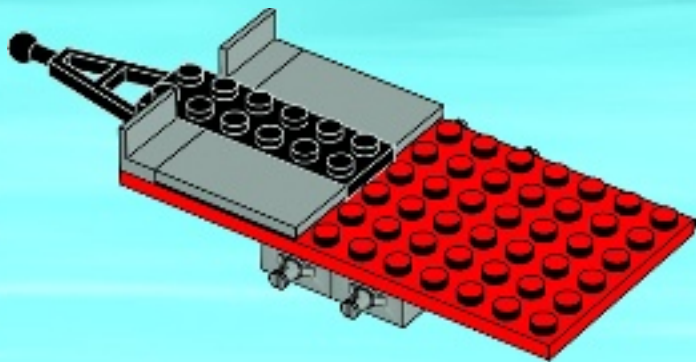

10

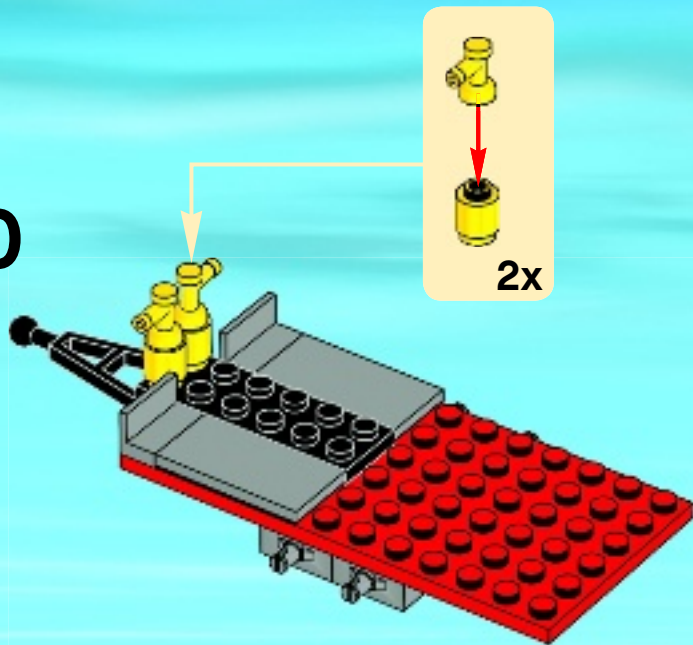

11

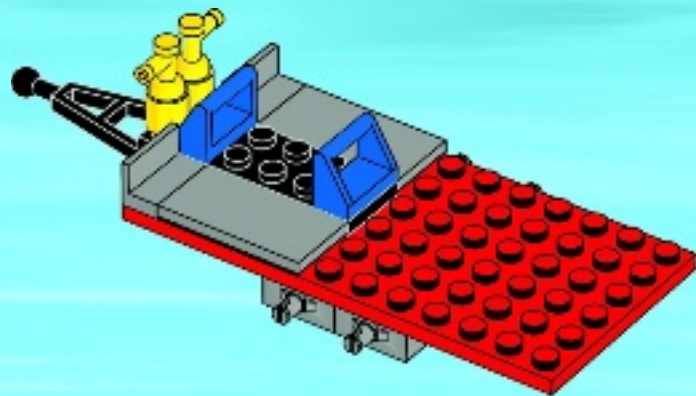

12

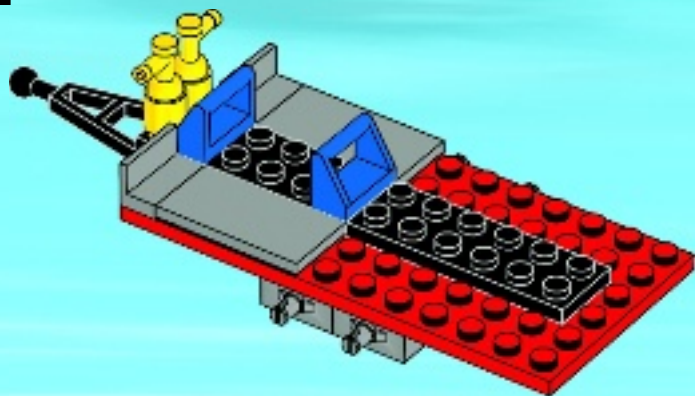



13

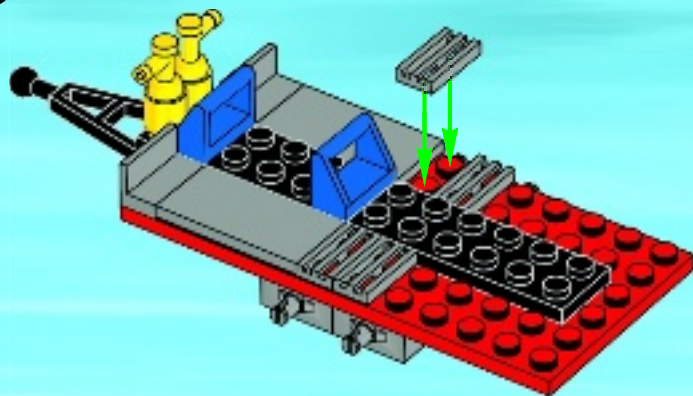

14

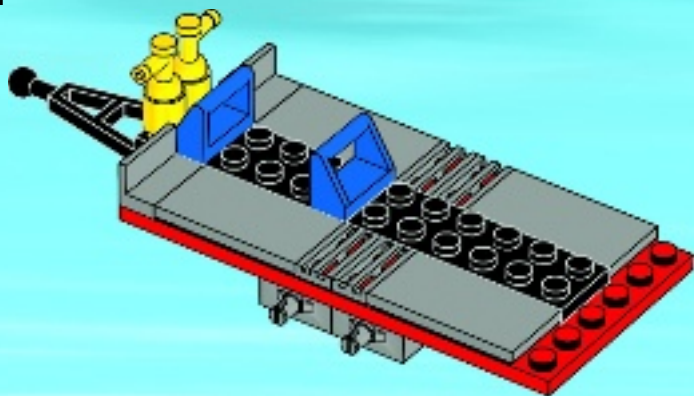

15

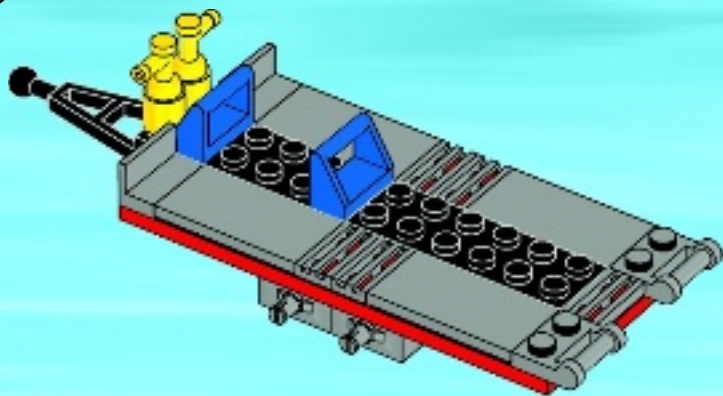

16

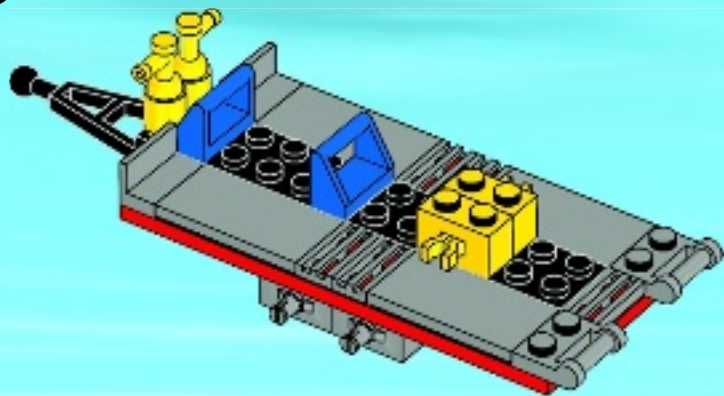

17

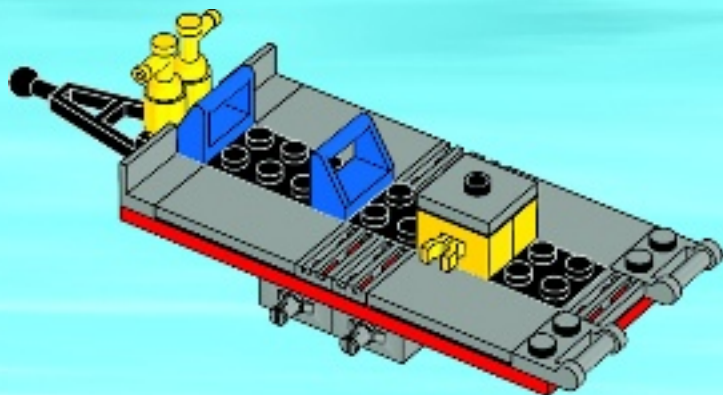



18

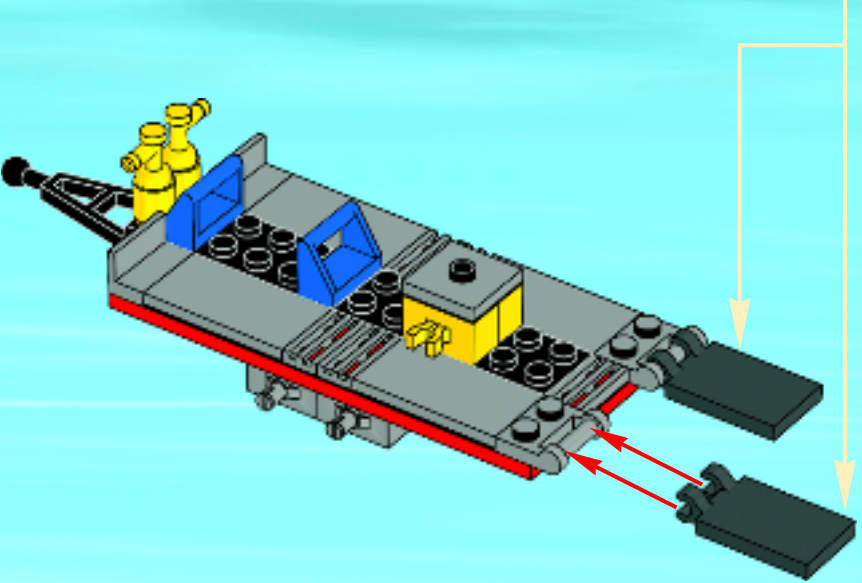



1



2



3



4



5



6





19

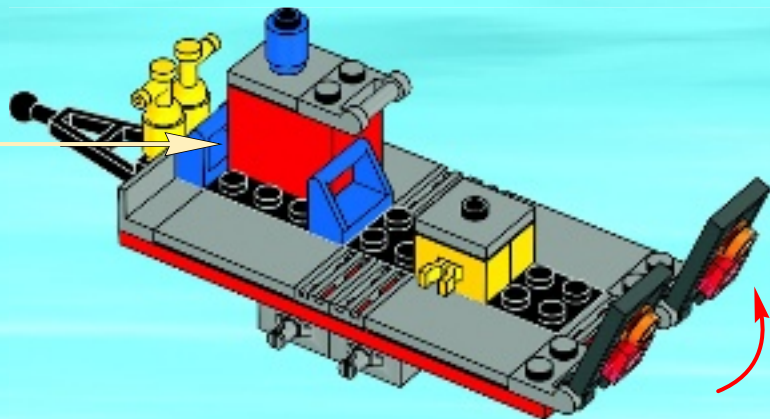



1



2



3



4



5



20

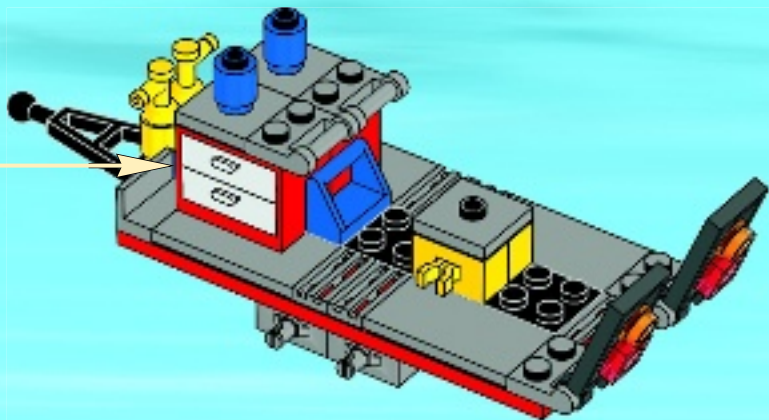

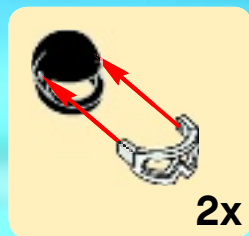

21

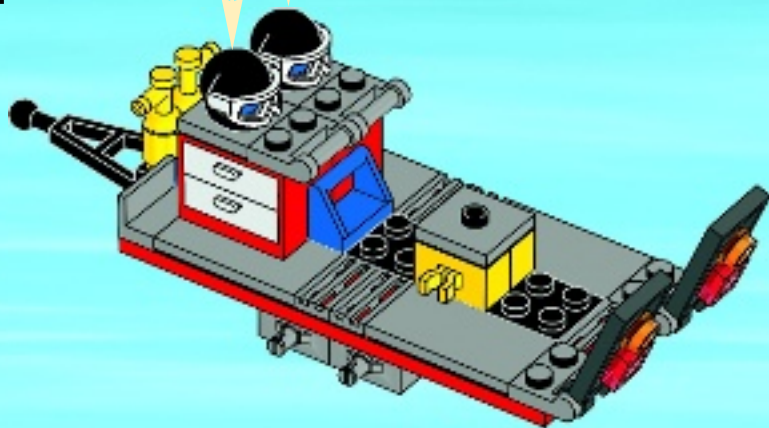

22

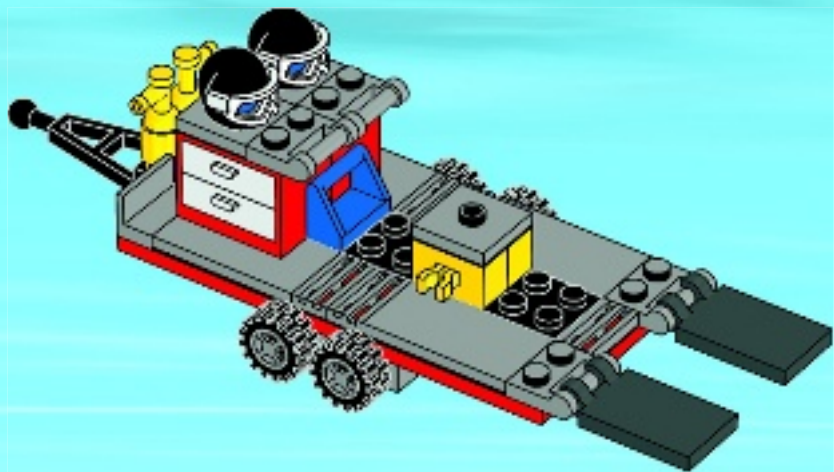

23





CITY



4431



4432



4433



4434



4435





CITY



4440



4439



4441



4437



4436



2x  
394201



2x  
4547489



4x  
4520636



2x  
4549059



4x  
4170457



1x  
4114319



1x  
4114309



1x  
4114001

**34**



2x  
346021



2x  
303221



1x  
4580871



2x  
4619543



1x  
4616800



1x  
371021



2x  
4648251



2x  
302321



2x  
4611701



2x  
4562544



1x  
4617409



1x  
4143199



2x  
447726



1x  
303226



2x  
4530673



1x  
4541984



1x  
366626



4x  
379526



1x  
4274405



1x  
4599499



2x  
4140303



1x  
4622570



1x  
4162443



4x  
4648117



1x  
4650145



2x  
4504382



2x  
255526



4x  
4598528



3x  
241226



1x  
4529064



2x  
4298619



4x  
4578677



5x  
4244953



4x  
4498340

2x  
4227517

1x  
4211067

1x  
407923

2x  
243223

2x  
4523407

1x  
9566

1x  
300323

2x  
306223

2x  
4275827

2x  
9341

1x  
4521107

1x  
4582183

6x  
4638658

1x  
4599456

2x  
4113206

1x  
302124

2x  
306224

2x  
4256320

1x  
4610938

1x  
4194395

2x  
4222960

2x  
302428

2x  
4244362

4x  
3000841

6x  
4650500

6x  
4211389

5x  
4590443

2x  
4251563

2x  
4211388

2x  
4211515

8x  
4211496

3x  
4565393

4x  
4211437

2x  
4211568

5x  
4211350

4x  
4211508

4x  
4211506

1x  
4211791

1x  
4211794

4x  
4244627

1x  
4211413

2x  
4211445

1x  
4211394

1x  
4648250

1x  
4618874

1x  
4211438

1x  
4211841

4x  
4560183



Customer Service

Kundenservice

Service Consommateurs

Servicio Al Consumidor

[www.lego.com/service](http://www.lego.com/service) or dial



: 00800 5346 5555

: 1-800-422-5346



# WIN!

Go to [www.LEGOsurvey.com/product](http://www.LEGOsurvey.com/product) to fill out a survey for a chance to win a cool LEGO® Product.

No purchase necessary.

Open to all residents where not prohibited.



## [www.LEGOsurvey.com/product](http://www.LEGOsurvey.com/product)

### GEWINNE!

Nimm an der Umfrage auf [www.LEGOsurvey.com/product](http://www.LEGOsurvey.com/product) teil und hab die Chance ein cooles LEGO® Produkt zu gewinnen!

Die Teilnahme am Gewinnspiel führt zu keinerlei Kaufverpflichtungen. Teilnahme in allen nicht ausgeschlossenen Ländern möglich.

### WIN!

Ga naar [www.LEGOsurvey.com/product](http://www.LEGOsurvey.com/product), vul een enquêteformulier in en maak kans op een cool LEGO® product.

Geen aankoopverplichting. Iedereen mag deelnemen, uitgezonderd ingezetenden van landen waar een enquêteverbod geldt.

### GAGNE!

Visite [www.LEGOsurvey.com/product](http://www.LEGOsurvey.com/product) pour répondre à un questionnaire et avoir une chance de gagner un produit LEGO® très cool!

Aucune obligation d'achat. Ouvert à tous les résidents des pays autorisés.

### 当てよう!

[www.LEGOsurvey.com/product](http://www.LEGOsurvey.com/product) にアクセスして、アンケートにご記入ください。当選者にはレゴ®製品を差し上げます。

お買い上げの必要はありません。禁止されていない限り、すべての皆様にご利用いただけます。



[www.LEGO.com](http://www.LEGO.com)

4667215

LEGO and the LEGO logo are trademarks of the LEGO Group. ©2012 The LEGO Group.