

LEGO MINDSTORMS™

STAR
WARS™

635

DROID™ DEVELOPER KIT

CONSTRUCTUCTION PROJECTS

9748

Welkom!

De Droid™ Developer Kit van LEGO MINDSTORMS™ brengt het universum van Star Wars tot leven. Met deze set kun je je eigen droiden bouwen en zo programmeren dat ze doen wat jij wilt.

Begin met het bouwen van een droid in deze Constructopedia, of sla de CD-ROM er op na voor andere mogelijkheden. En je kunt natuurlijk ook je eigen verbeelding laten spreken.

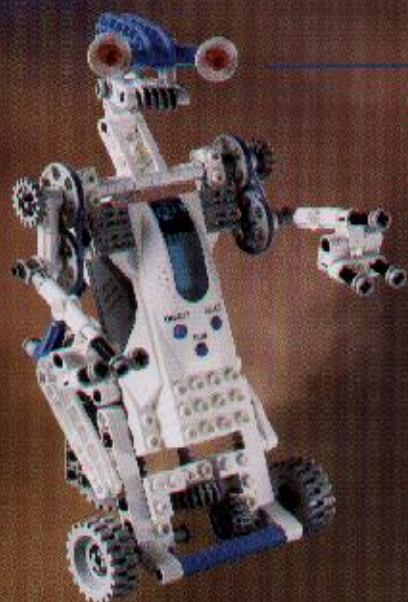

L-3GO Trainer droid™

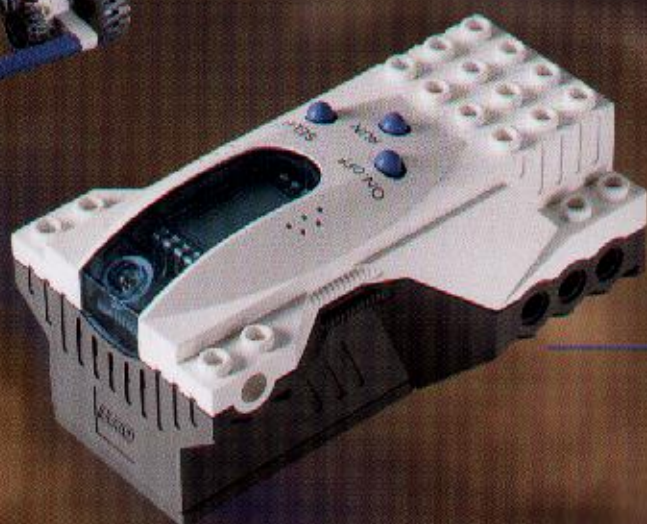

R2-D2™ Astromech droid™

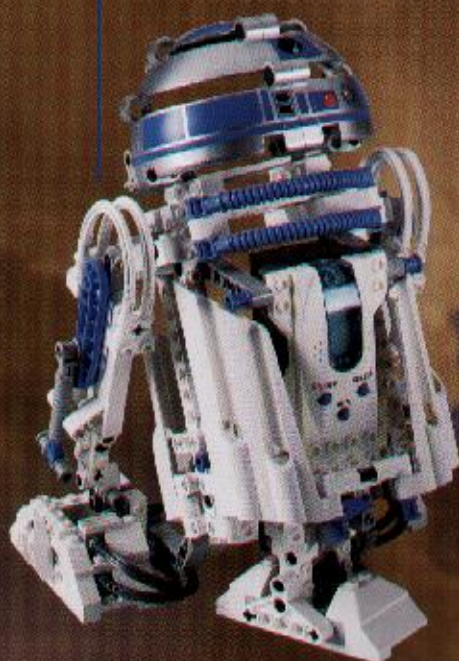

Jedi-ridder droid™

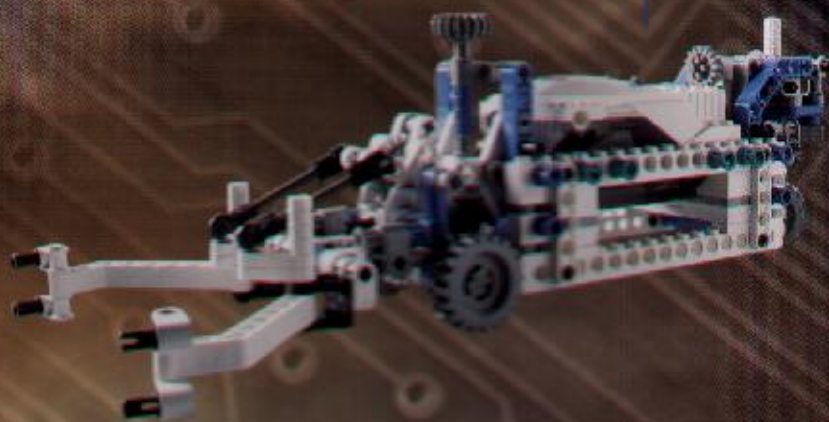

INHOUD

Inleiding	<i>pag.</i> 4
Beginnen Batterijen plaatsen, het gebruik van de lichtsensor, het gebruik van de knoppen en de display.	<i>pag.</i> 6
Bouwaanwijzingen	<i>pag.</i> 11
<i>L-3GO Trainer droïde™</i>	<i>pag.</i> 12
<i>R2-D2™ Astromech droïde™</i>	<i>pag.</i> 38
<i>Jedi-ridder droïde™</i>	<i>pag.</i> 82
Speciale toepassingen Uitbreidingen voor je droïden.	<i>pag.</i> 111
Technische toestanden	<i>pag.</i> 117
<i>Droid™ Developer Kit CD-ROM</i>	<i>pag.</i> 118
<i>Tips en hints</i>	<i>pag.</i> 120

Maak kennis met de Micro Scout

De Micro Scout is een slim LEGO element met een ingebouwde microcomputer. Met de Micro Scout kun je je eigen droïden bouwen en ze zo programmeren als jij dat wilt.

- De Micro Scout heeft ook een ingebouwd motortje waarmee je de droïden kunt laten bewegen.
- Hij heeft een lichtsensor waarmee je droïden op licht kunnen reageren.
- Daarnaast zit er een display op en zijn er knoppen waarmee je kunt bepalen wat je droïde doet.



De Micro Scout heeft verschillende programma's waarmee je het gedrag van de droïde kunt bepalen.

Hoe werkt het?

De *Micro Scout* werkt net als de droïden die je uit het universum van Star Wars kent... nou ja, bijna dan.

1. De *Micro Scout* gebruikt zijn lichtsensor om lichtverschillen te kunnen detecteren.
2. Als de sensor een lichtverandering 'ziet', zendt hij een signaal naar het brein van de *Micro Scout* (een computerchip).
3. Het brein bepaalt dan wat er gedaan wordt, bijvoorbeeld de motor aanzetten of een geluidje afspelen.

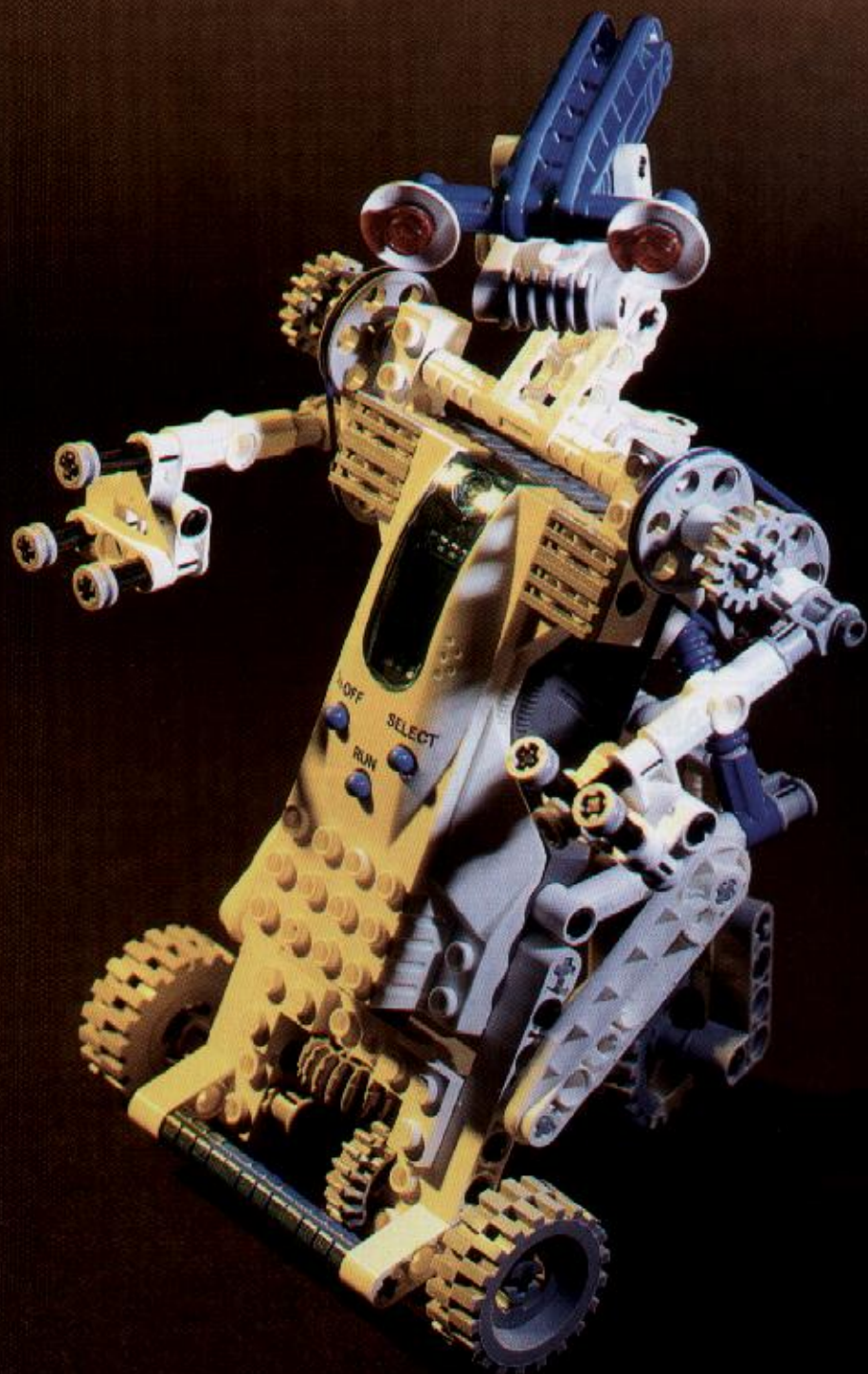

BATTERIJEN PLAATSEN

De Micro Scout heeft twee AA/LR6 batterijen nodig (niet bij de set inbegrepen). Het is raadzaam alkaline batterijen te gebruiken.

1. Open de Micro Scout door het batterijdeksel in de richting van de twee pijltjes te duwen.
2. Plaats de twee batterijen.
3. Schuif het batterijdeksel weer dicht.

Belangrijk:

Als de batterijen in de Micro Scout bijna leeg zijn, verschijnt er een symbooltje van een batterij  op de display.

Aanwijzingen bij het gebruik van het batterijvak

Gebruik nooit verschillende types batterijen of zowel oude als nieuwe batterijen in één batterijvak. Haal de batterijen altijd uit het batterijvak als je ze langere tijd niet gebruikt of als ze bijna leeg zijn. De vloeistof die uit lege batterijen kan lekken, kan het batterijvak beschadigen.

FCC verklaring

Dit product voldoet aan deel 15 van de regels van de FCC. Aan de volgende twee voorwaarden wordt tijdens de werking voldaan: (1) Het apparaat mag geen schadelijke storingen veroorzaken, en (2) dit apparaat moet stoorsignalen die onjuiste werking kunnen veroorzaken accepteren.

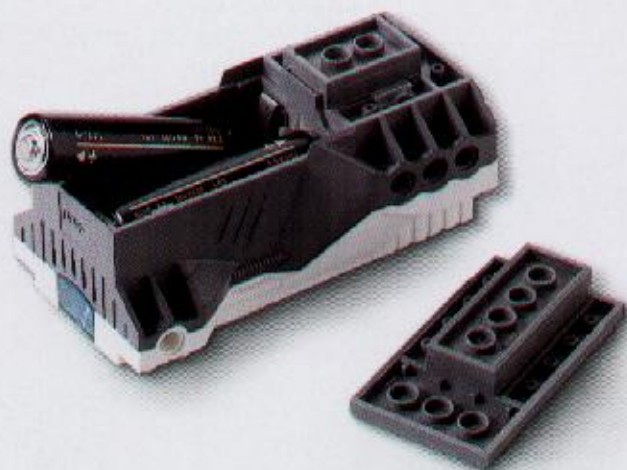

HET GEBRUIK VAN DE KNOPPEN

ON-OFF (AAN-UIT)

Met de ON-OFF knop wordt de Micro Scout aan- en uitgezet.

Als de Micro Scout aan staat, is hij klaar om opdrachten te ontvangen

RUN (UITVOEREN)

Met de RUN knop wordt de Micro Scout gestart en gestopt.

Als een programma wordt uitgevoerd, wordt het nummer daarvan knipperend op de display weergegeven.



SELECT

(PROGRAMMAKEUZE)

Met de SELECT knop kun je de 7 ingebouwde programma's en het P programma langs lopen.*

** Neem een kijkje op www.legomindstorms.com/jddk voor meer informatie over het P programma*

LICHTSENSOR

Aan de voorkant van de Micro Scout is een lichtsensor ingebouwd. Hiermee kan de Micro Scout lichtverandering 'zien'.

De lichtsensor is onder een hoek van 45 graden geplaatst.

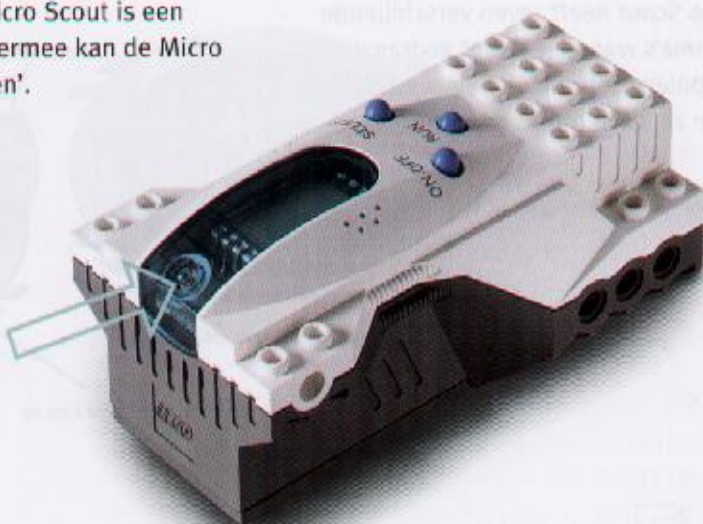

Als je de draide met lichtsignalen bestuurt, richt den de lichtstraal altijd rechtstreeks op de lichtsensor.



Checkpoint: lichtsensor

1. Zorg ervoor dat de Micro Scout aan staat.
2. Druk op **Select** totdat programma 6 op de display wordt weergegeven.
Dit is het 'Alarm' programma
3. Druk op **Run**.
De Micro Scout geeft een geluidssignaal terwijl hij het lichtniveau meet.
4. Dek de lichtsensor af met je hand of richt er een lichtflits op om het alarm te activeren.
Het alarm is nu hoorbaar en de motor draait.



PROGRAMMA'S

De Micro Scout heeft zeven verschillende programma's waarmee je het gedrag ervan kunt bepalen. Gebruik de Select en de Run knop om ze uit te proberen.

- *Andere droïden kunnen ander rijgedrag vertonen dan L-3Go, afhankelijk van de overbrenging en het mechanisme.*

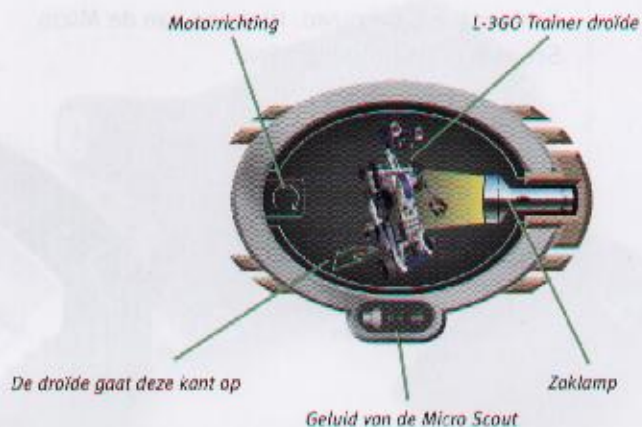

EEN RICHTING



L-3GO rijdt terug

TWEE RICHTINGEN



L-3GO rijdt eerst naar achteren.

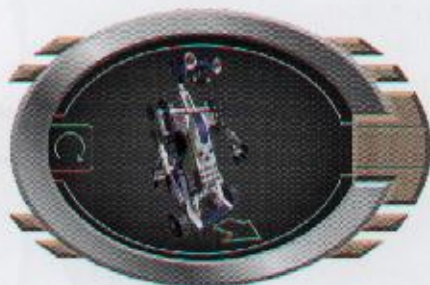

En dan rijdt L-3GO naar voren.

3

ZOEK HET LICHT OP

BOUWAANWIJZINGEN



L-3GO rijdt terug.

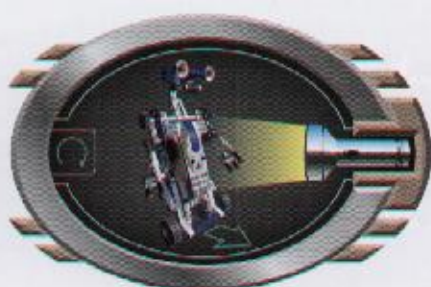

Als L-3GO licht ziet, rijdt hij naar voren.

4

LICHTBESTURING



L-3GO staat stil.

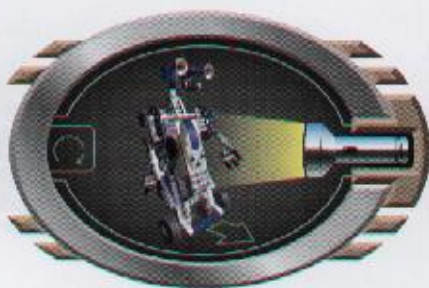

Als L-3GO licht ziet, begint hij te bewegen.

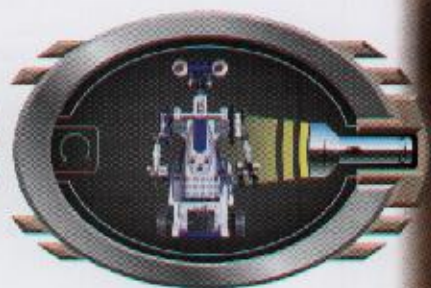

Als L-3GO twee lichtflitsen detecteert, verandert de droid van richting.

5

OVERLEVING



L-3GO staat stil.



Als er een lichtflits wordt gegeven, begint L-3GO naar voren te rijden en maakt hij snelheid.

6

ALARM

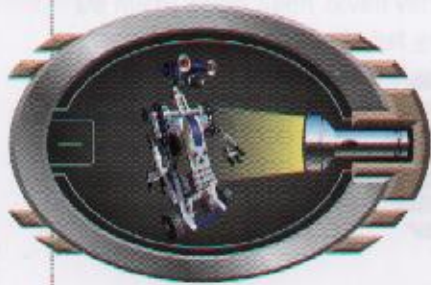

L-3GO wacht op een lichtverandering.



Als L-3GO een lichtverandering 'ziet', gaat er een alarm af en begint de droïde heen en weer te bewegen.

7

CODE



L-3GO speelt een reeks korte en lange pieptonen af.



Herhaal deze reeks met je zaklamp.



Als de code correct is, rijdt L-3GO heel even naar voren.



Als de code correct is, rijdt L-3GO heel even naar achteren.

P

CONTROL

Het P programma is ontworpen om te worden gebruikt met toekomstige MINDSTORMS producten. Zie www.legomindstorms.com/dak voor meer informatie.

BOUWAANWIJZINGEN

Deel 1 - L-3GO Trainer droïde™

Deel 2 - R2-D2™ Astromech droïde™

Deel 3 - Jedi-ridder droïde™



BOUWAAFWIJZINGEN

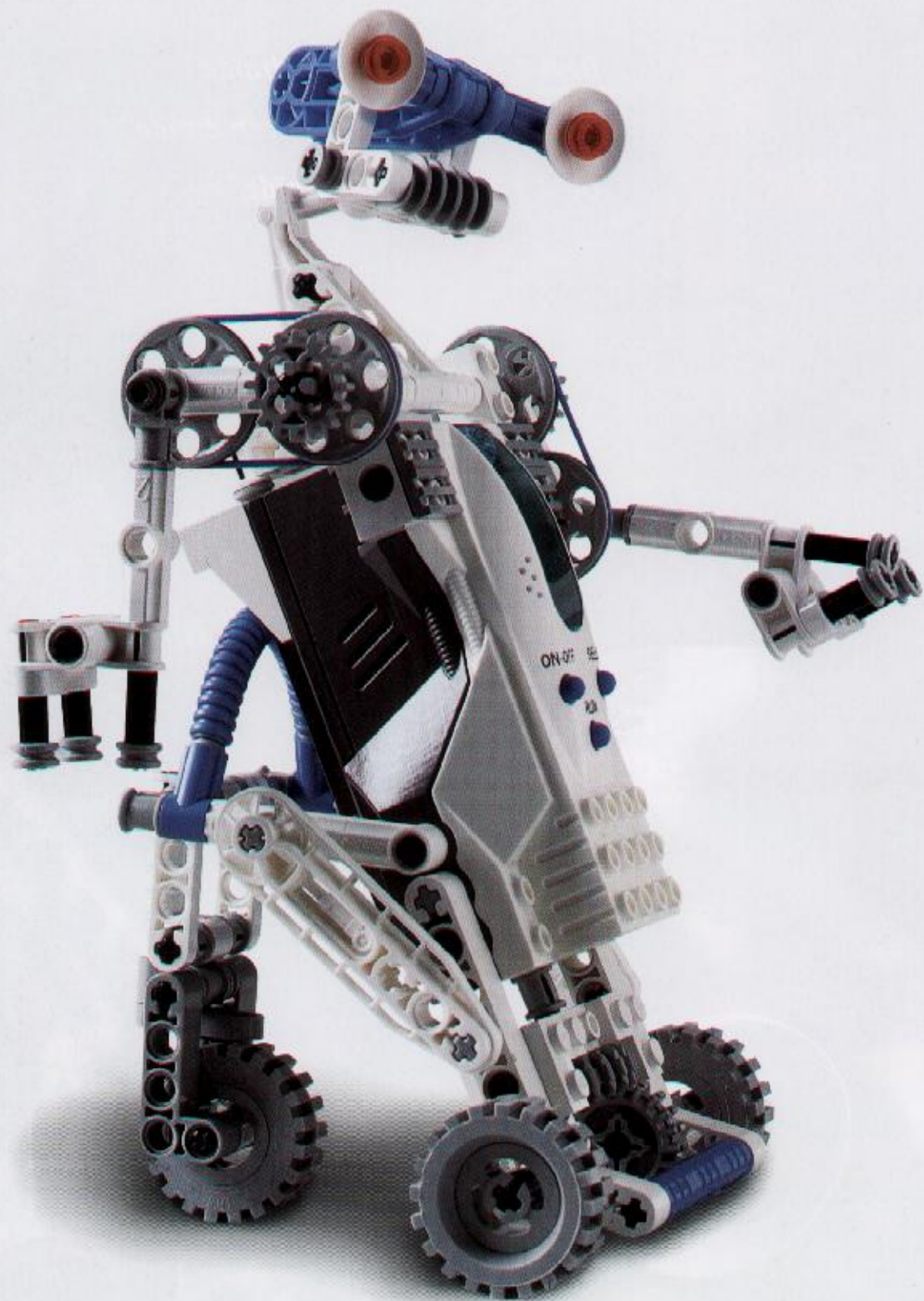



1

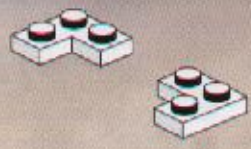

2

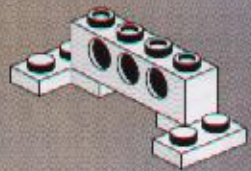

3

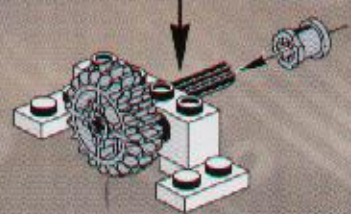
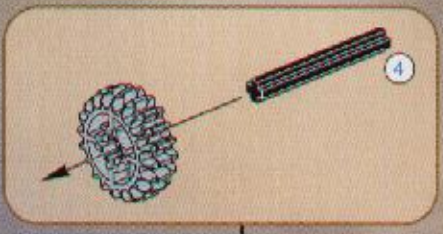



4

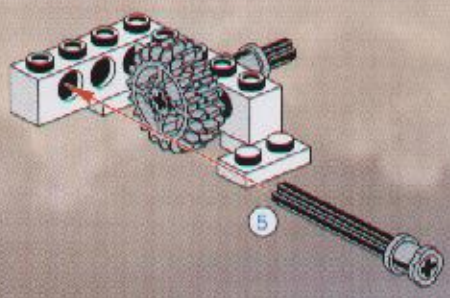
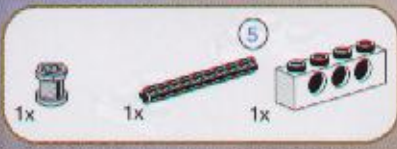

5

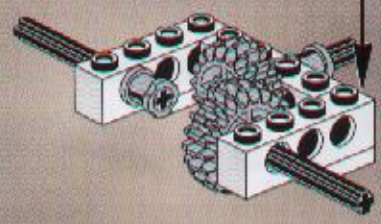
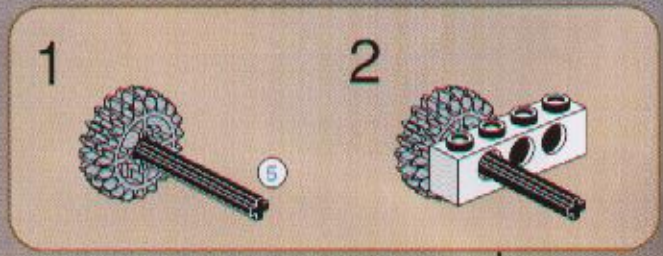

6

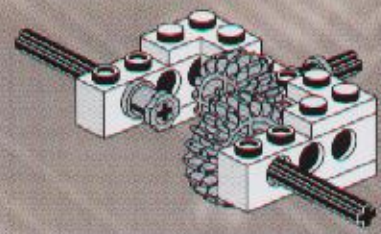

LEGO® is a trademark of the LEGO Group of companies.

7

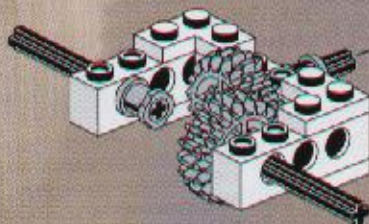
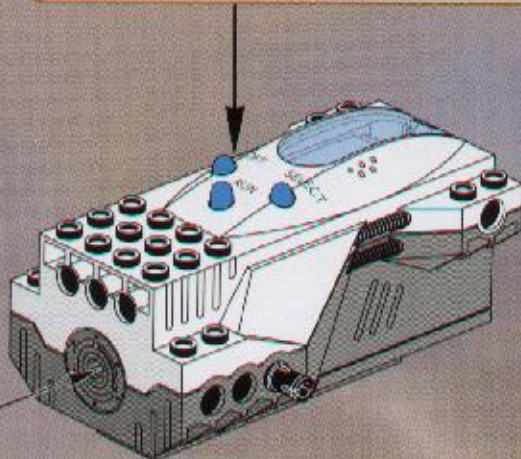
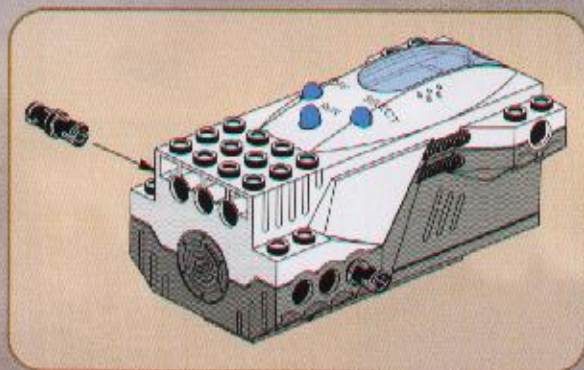
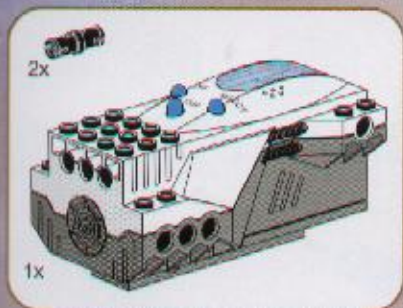

8

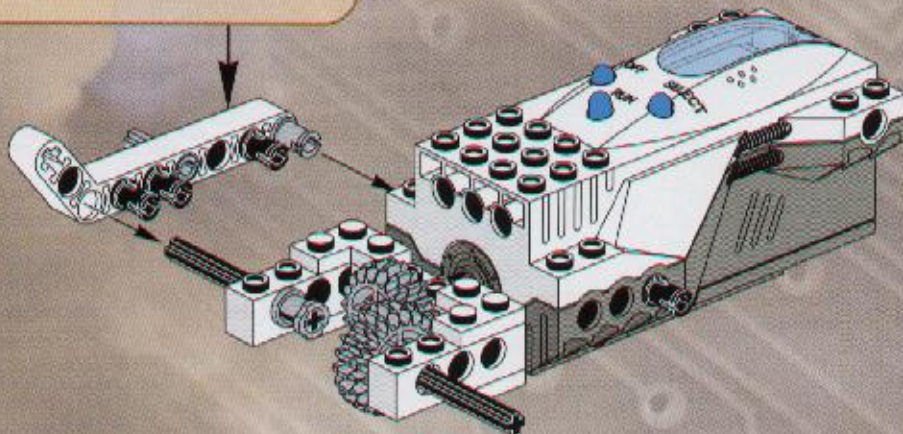
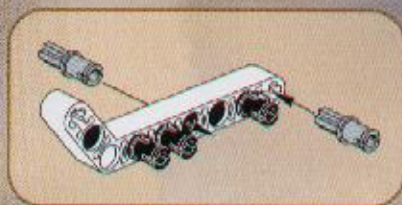
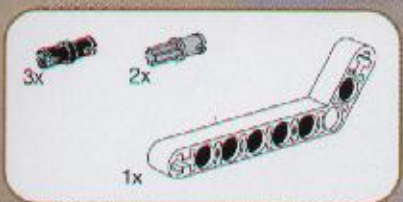



9

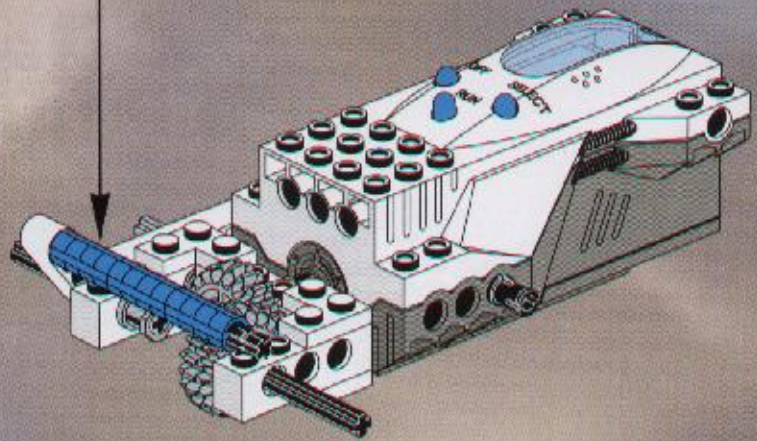
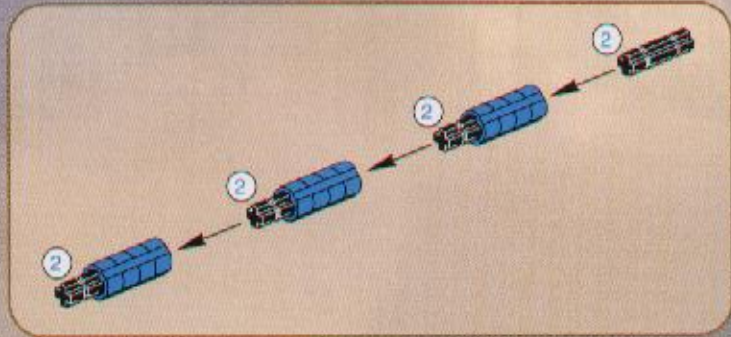
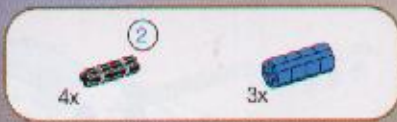

10

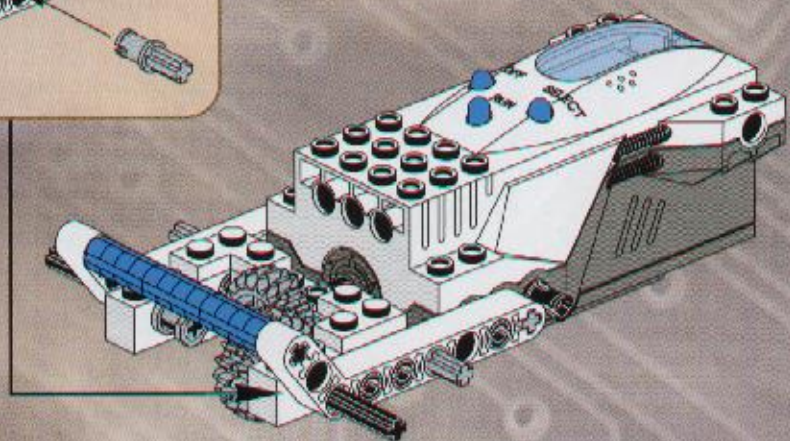
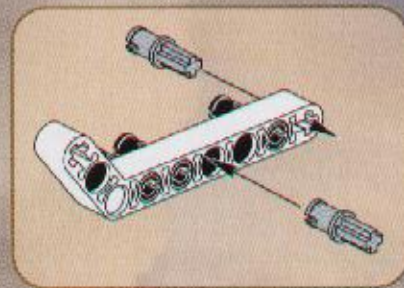
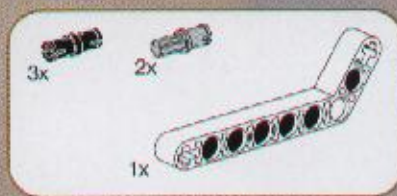

11

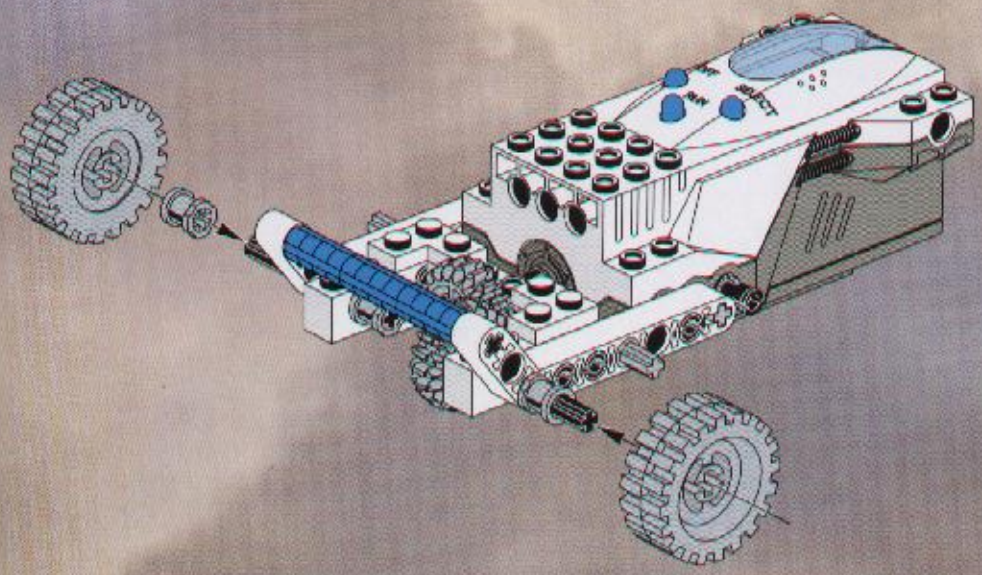

12

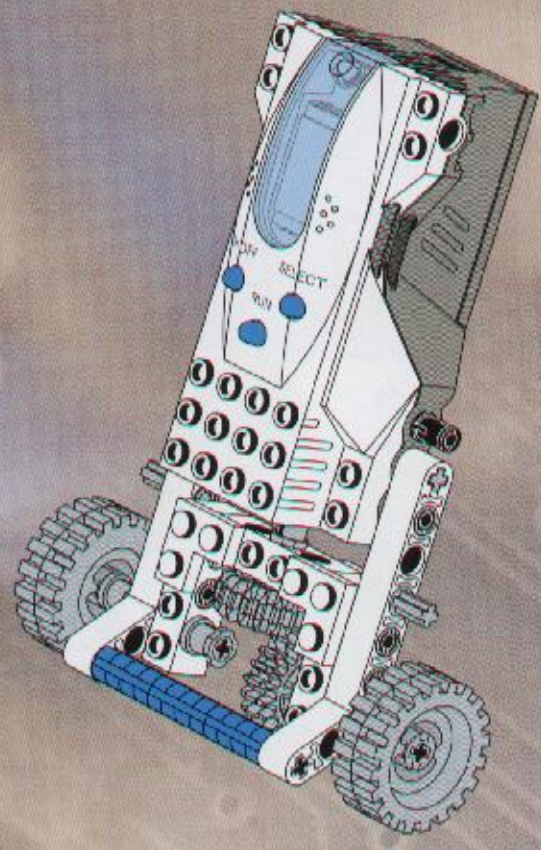



1

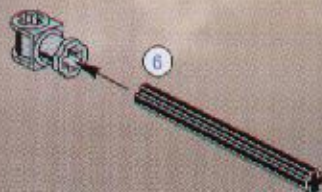

2

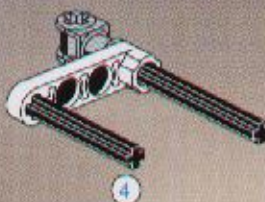

3

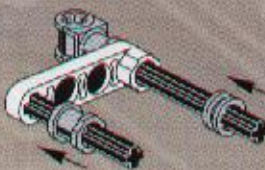

4

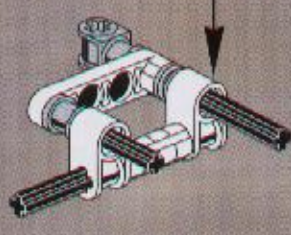
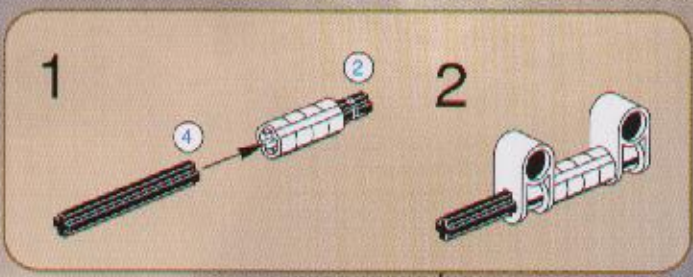
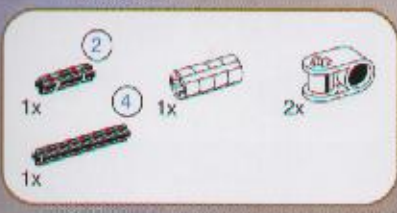

5

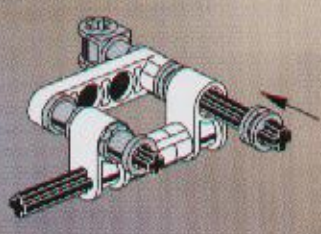
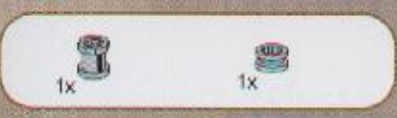

6

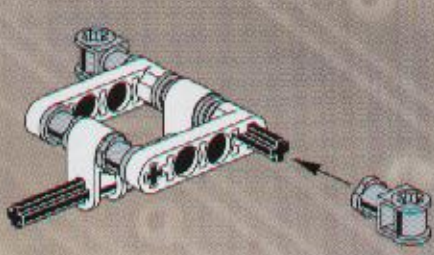
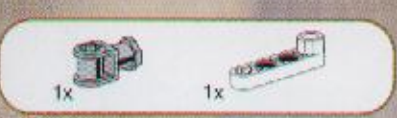



7

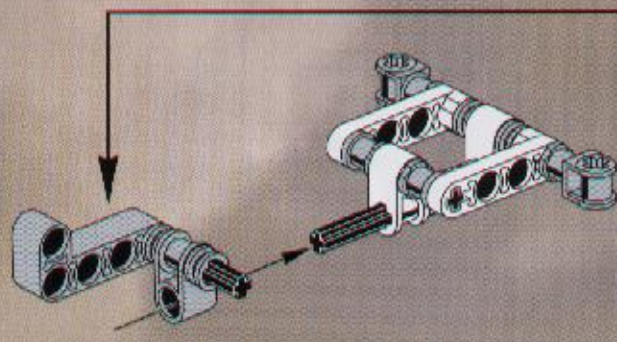
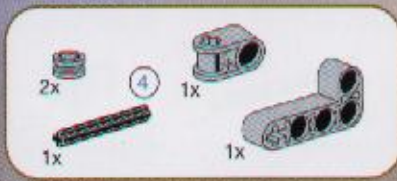

8

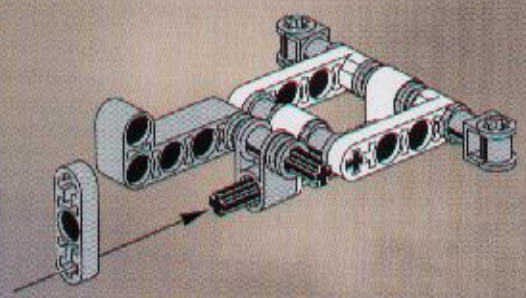

9

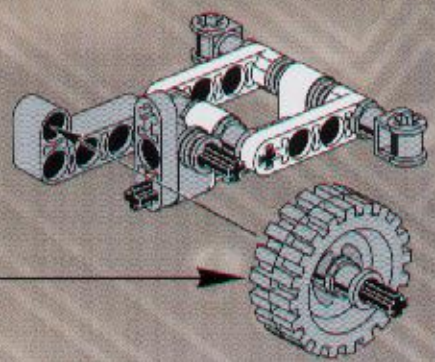
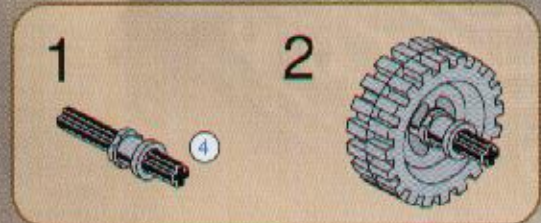
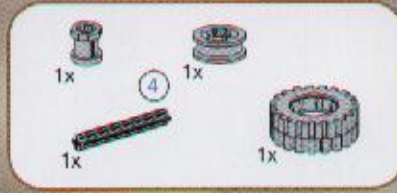

10

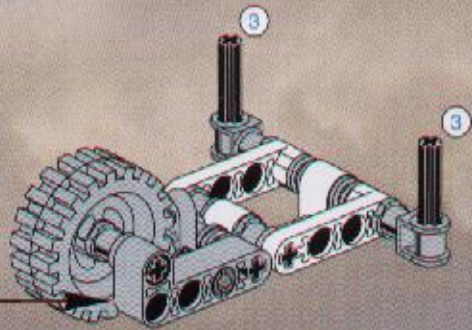
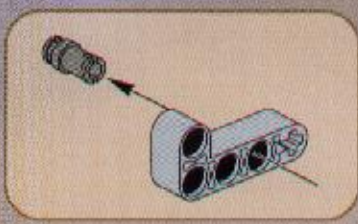

11

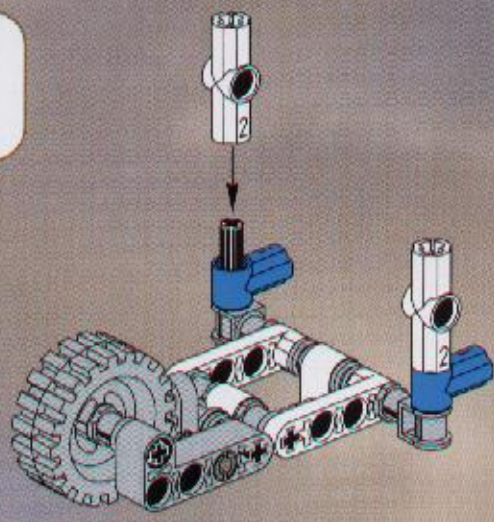

12

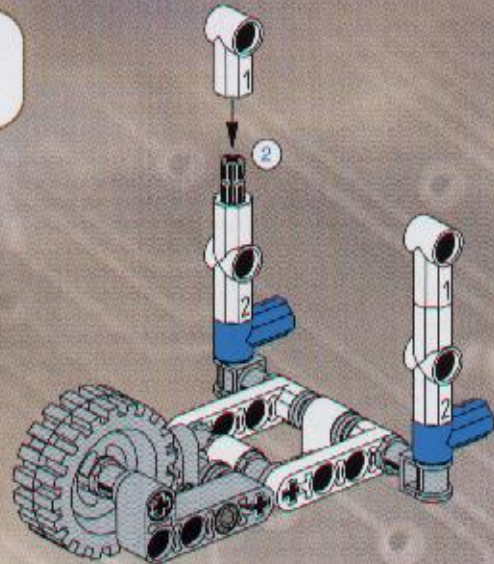
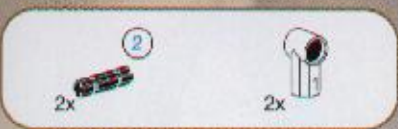



13

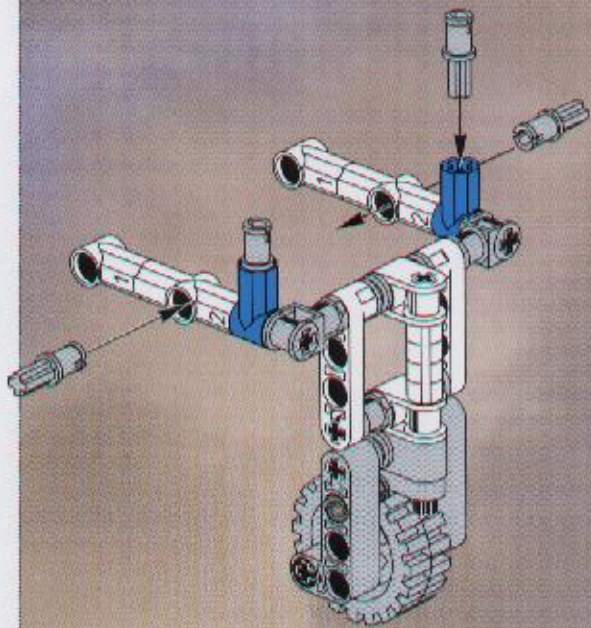

14

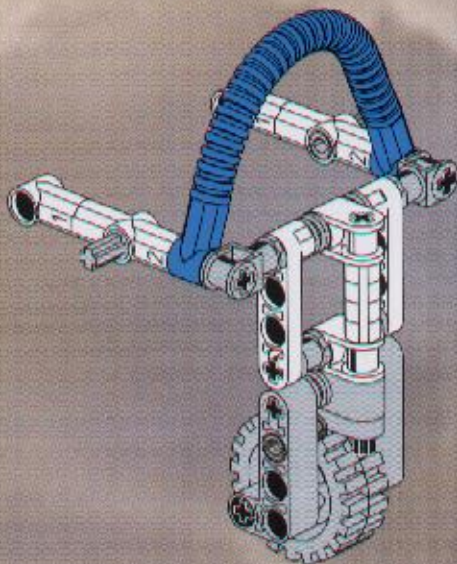

13

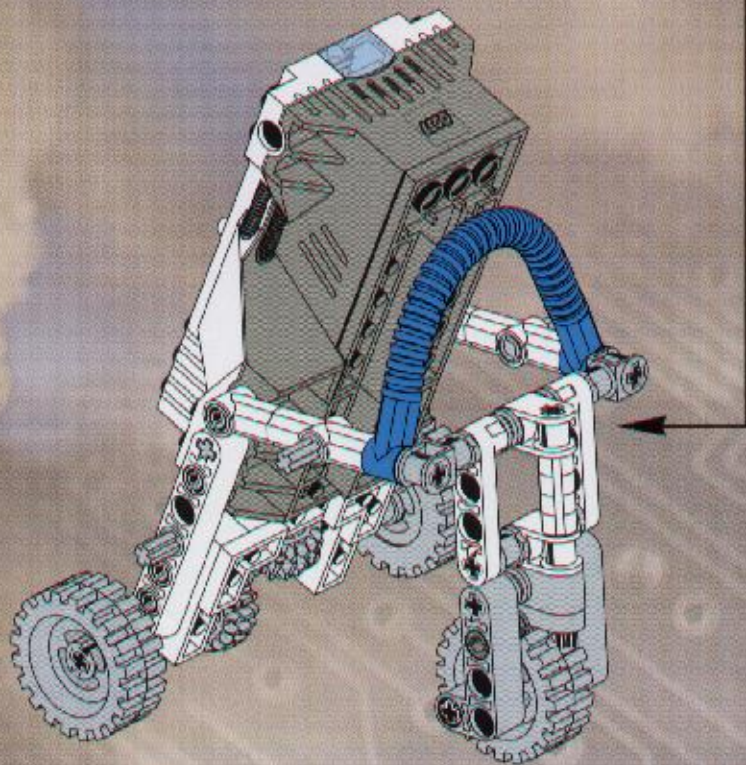

14



2x

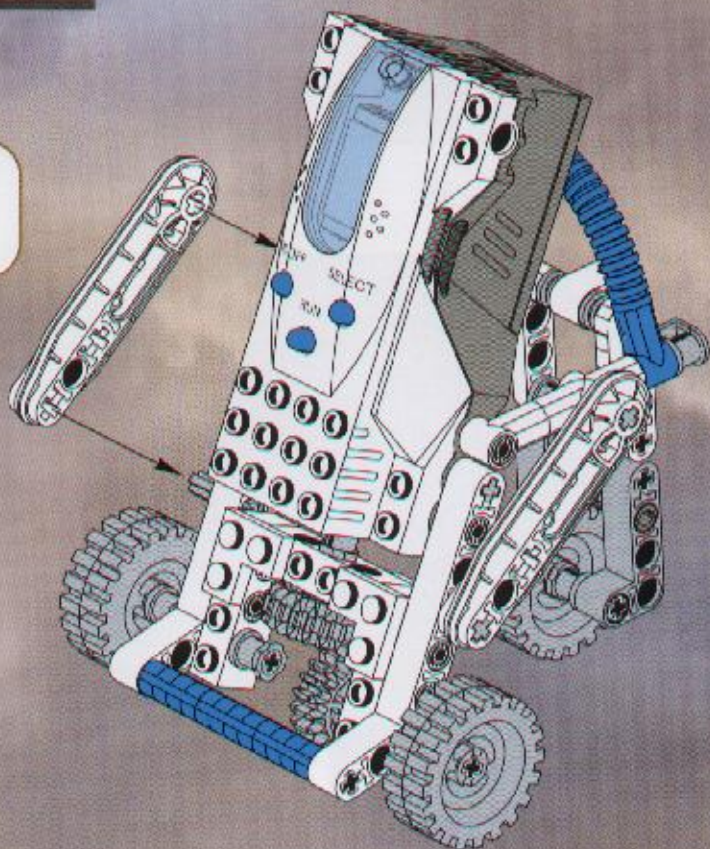

15

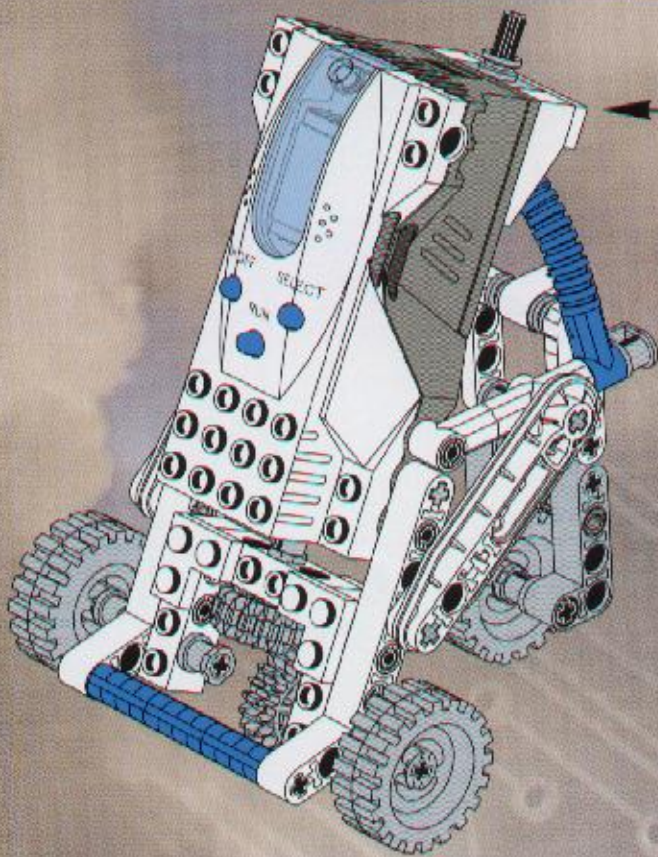
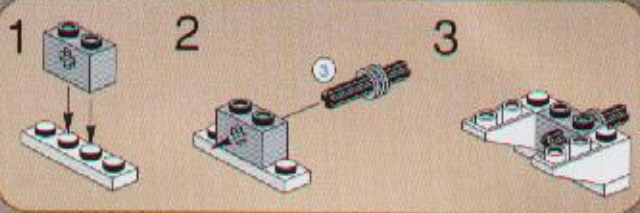
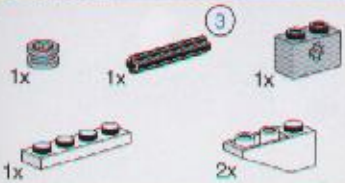



1



2

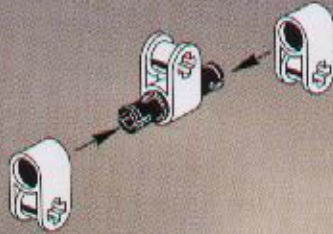

3

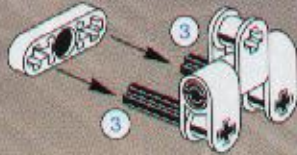

4

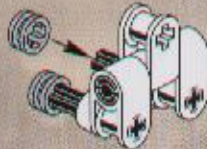

5



6

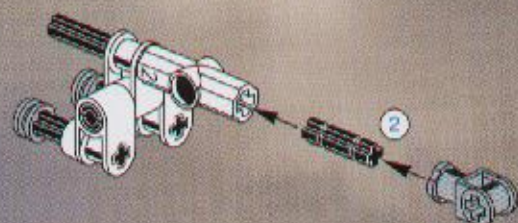
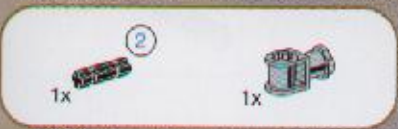

7

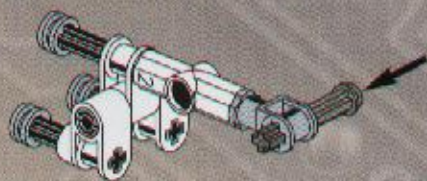
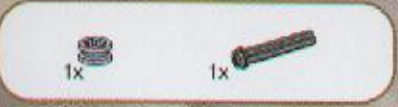



8

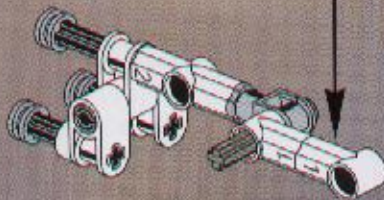
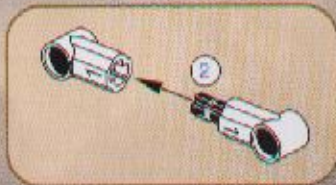

9

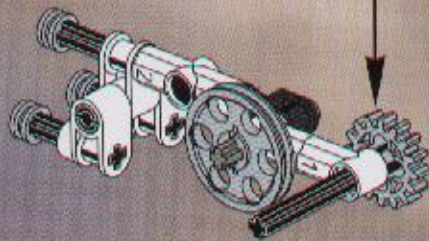
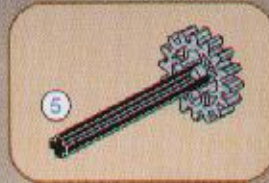

10

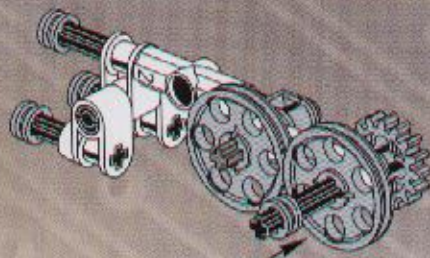
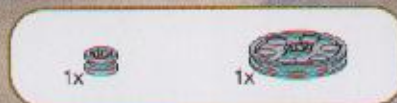



11

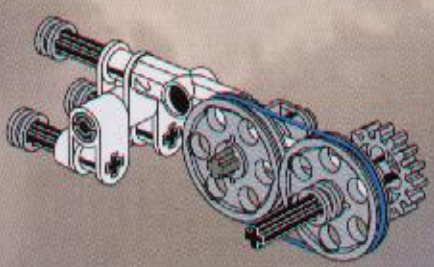

12

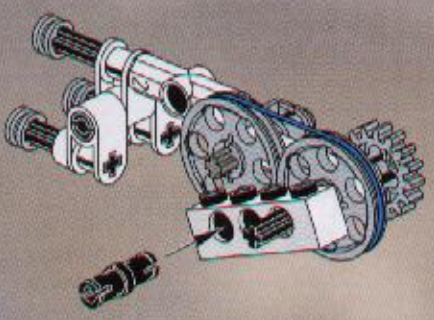

13

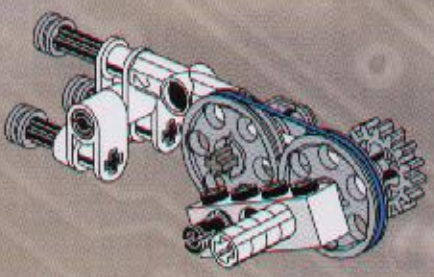



16

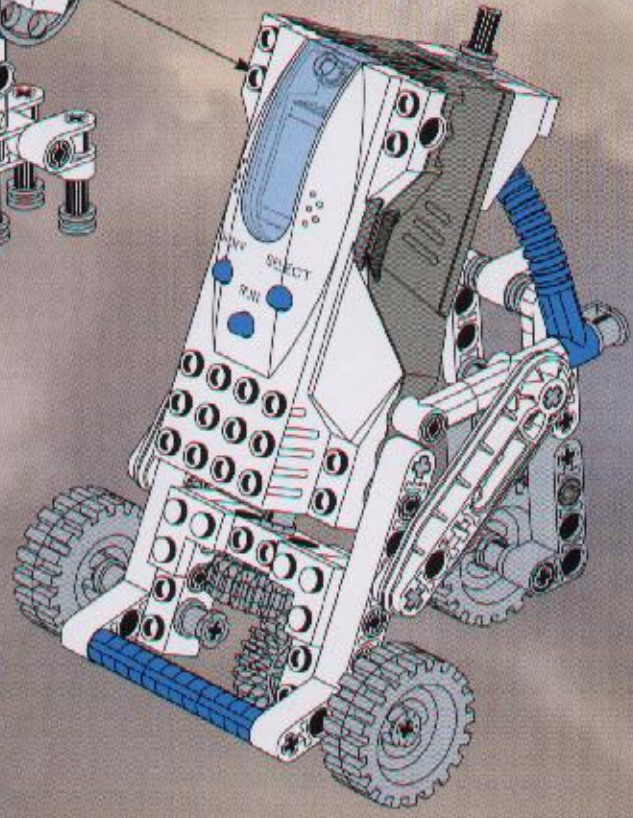
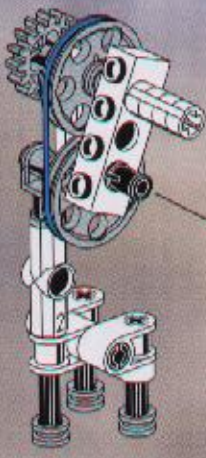

17

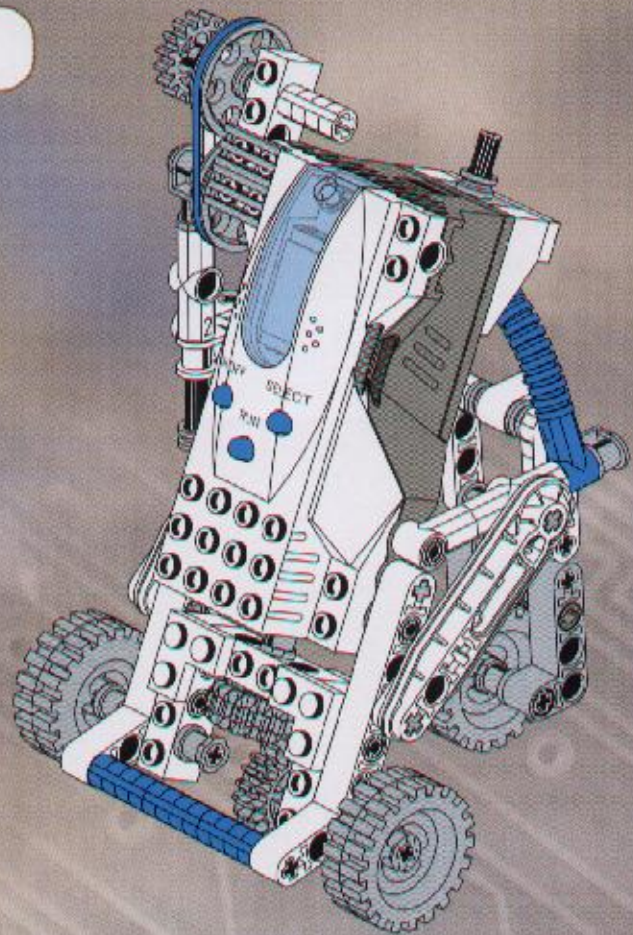

1

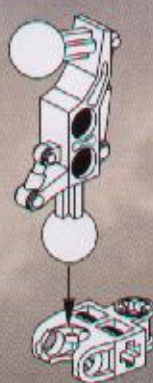

2

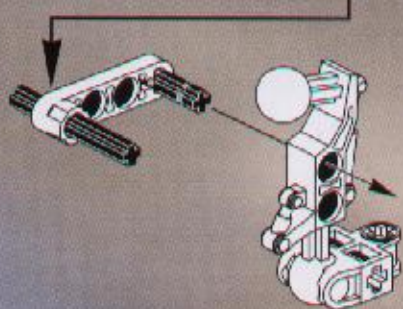
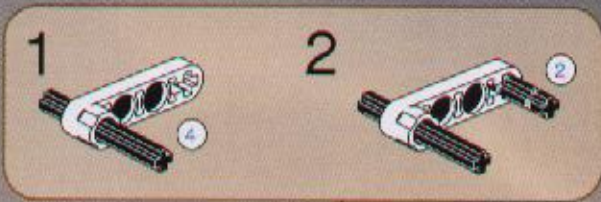
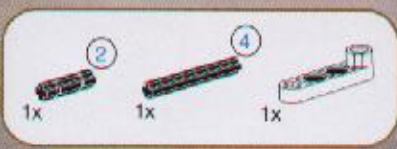

3

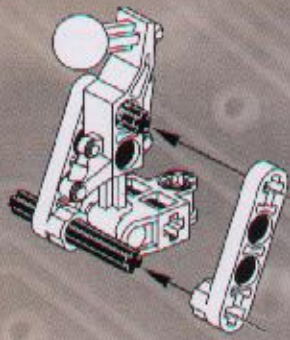



4

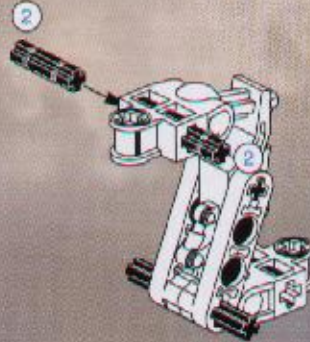

5

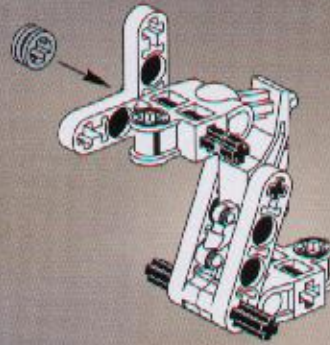

6

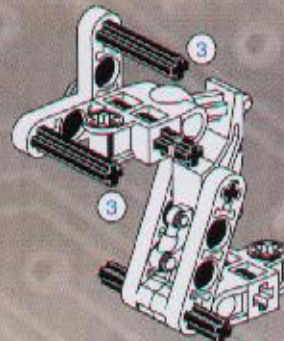

7

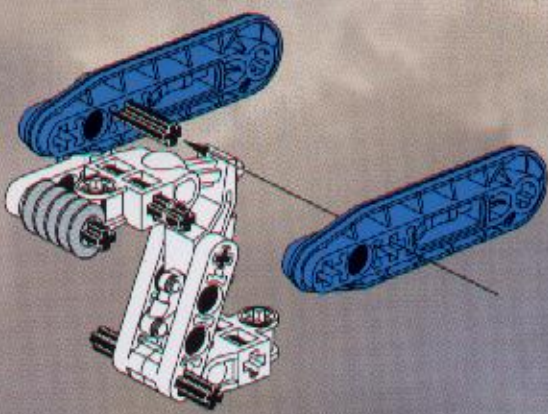

8

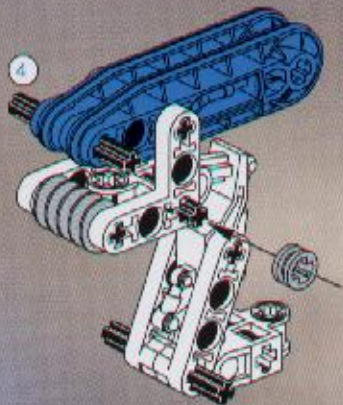

9

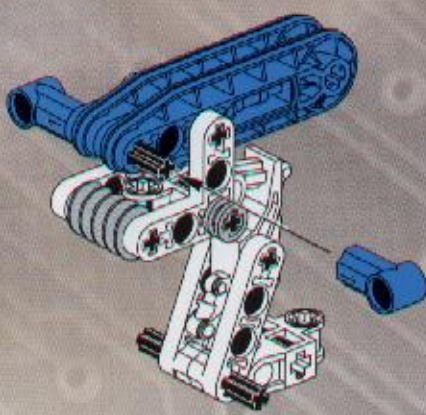



10

- 2x
- 2x

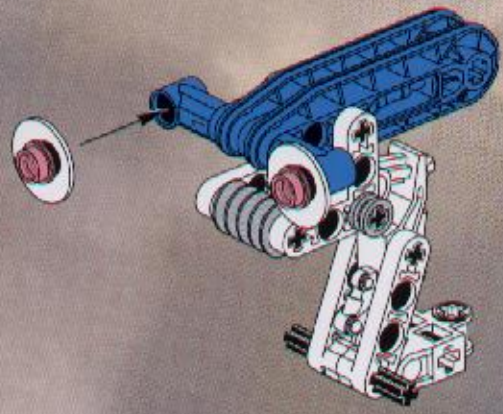

18

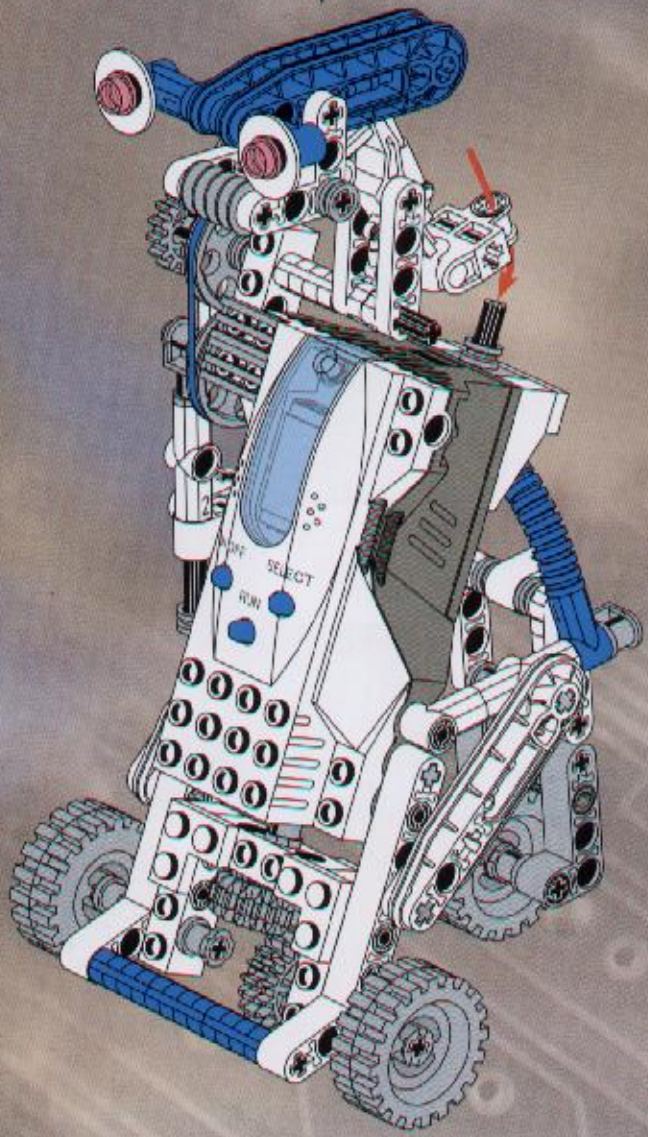

1



2

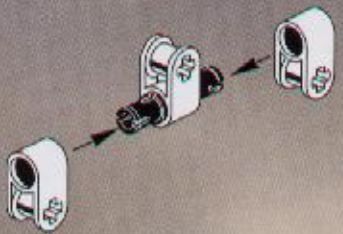

3

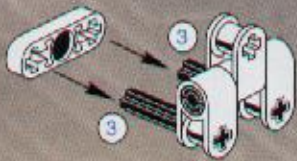

4

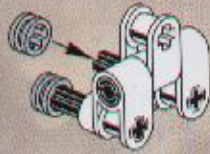

5

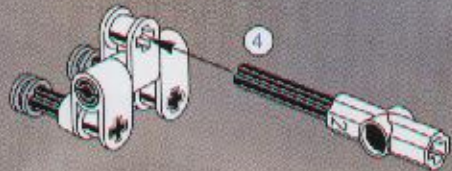

6

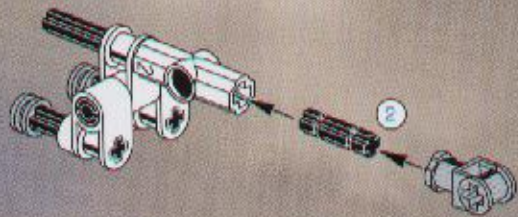
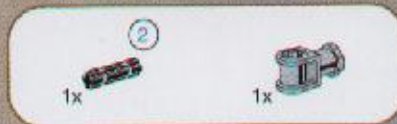

7

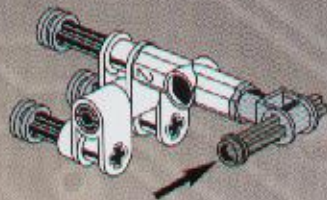
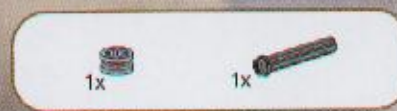

8

- 1x  2
- 2x 

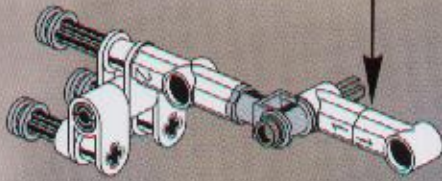
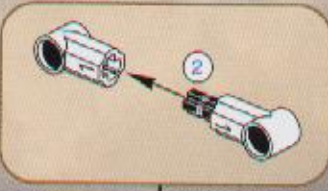

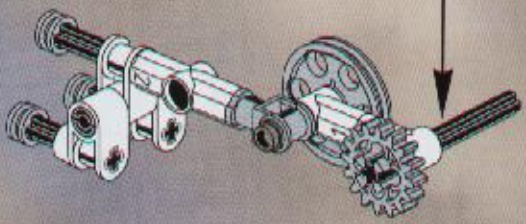
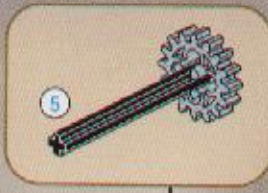

9

- 1x  6
- 1x 
- 1x 



10

- 1x 
- 1x 

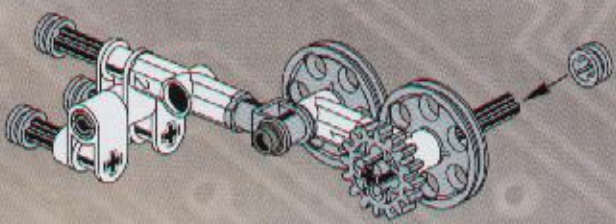



11

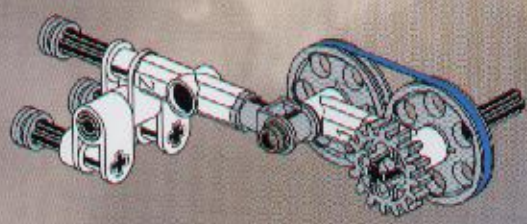

12

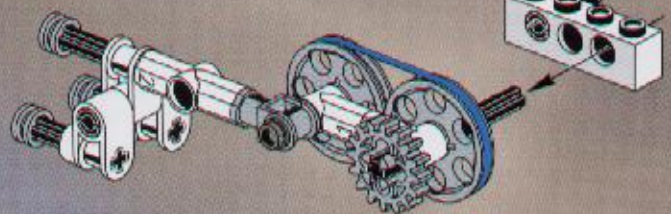
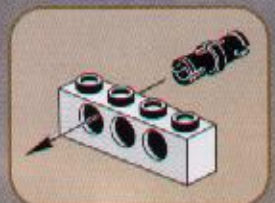

13

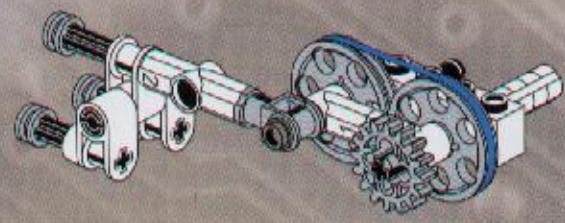

19

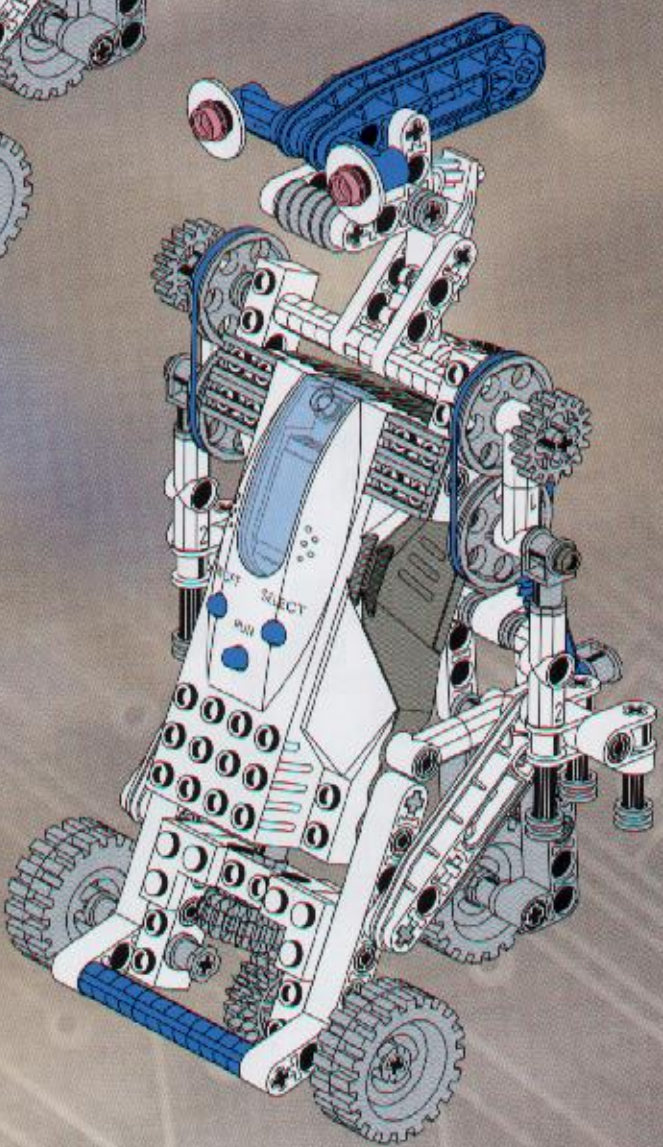
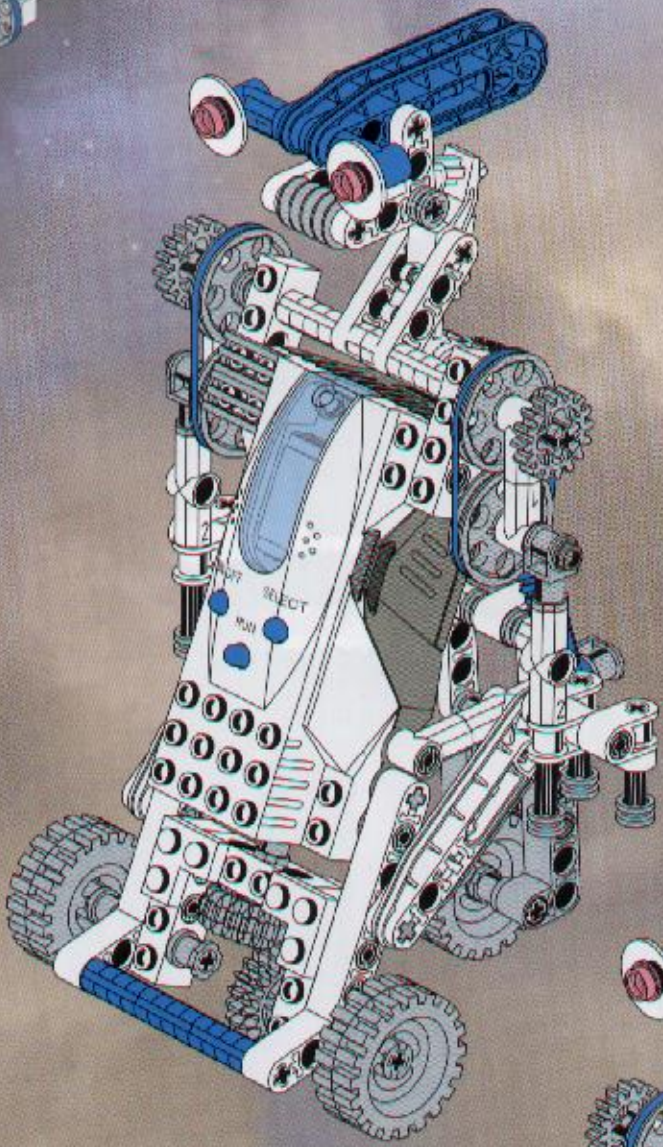

20

BOUNCEWAVE/STINGEN

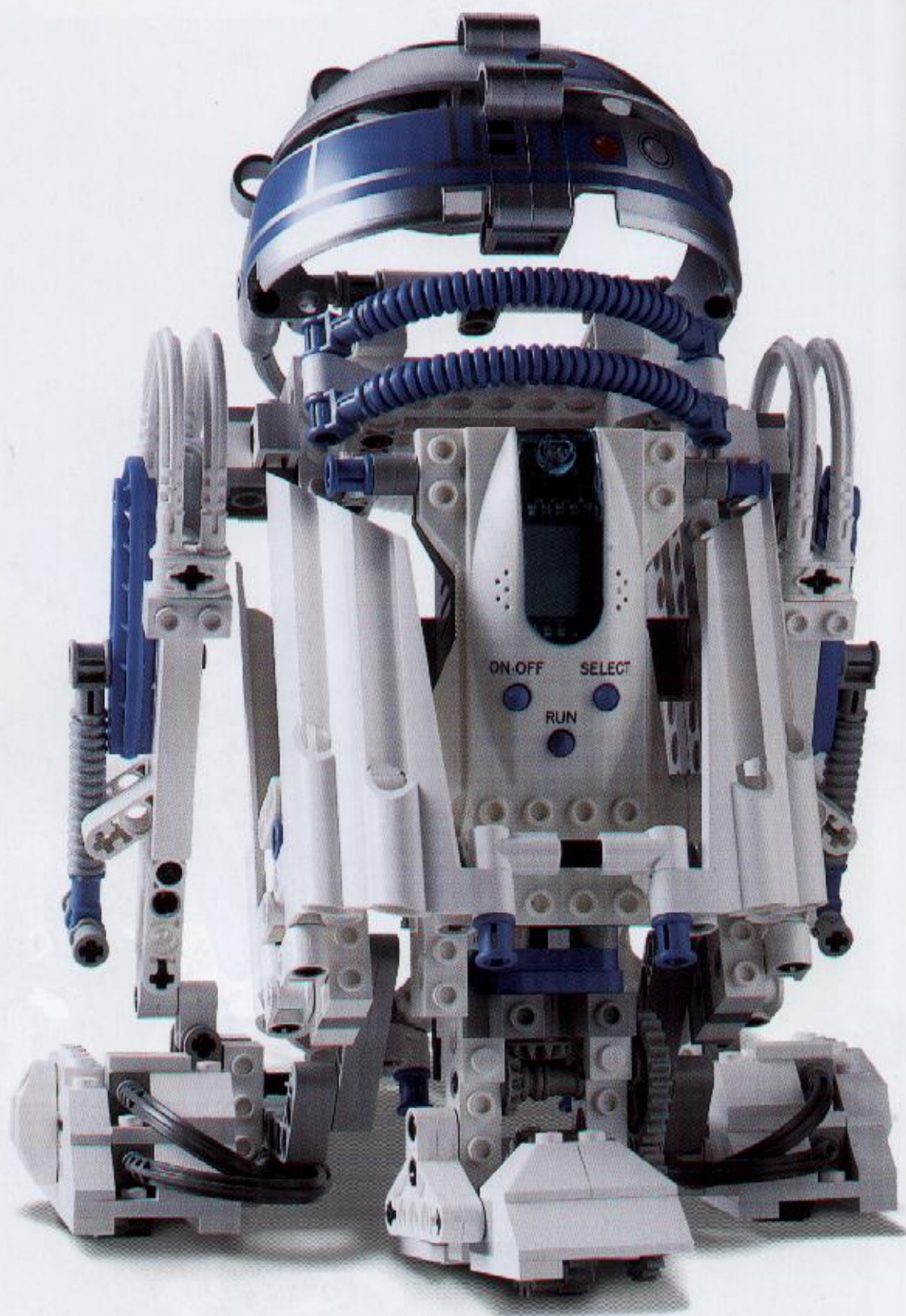

1

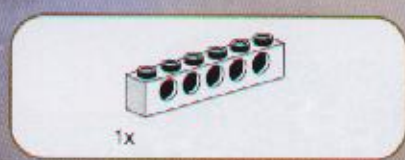

2

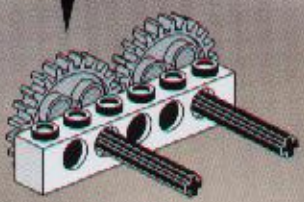
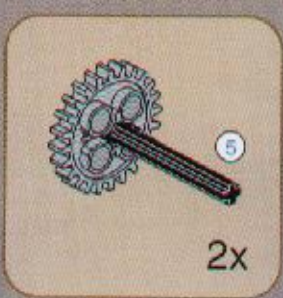
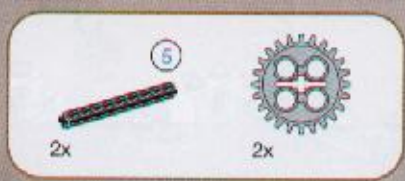

3

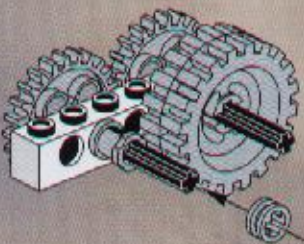

4

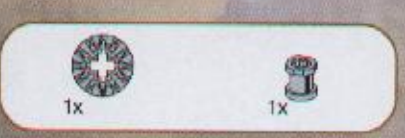



5

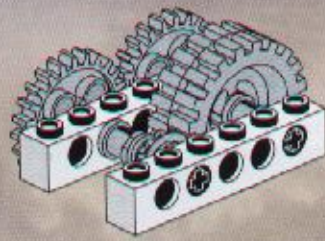
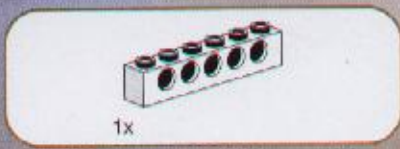

6

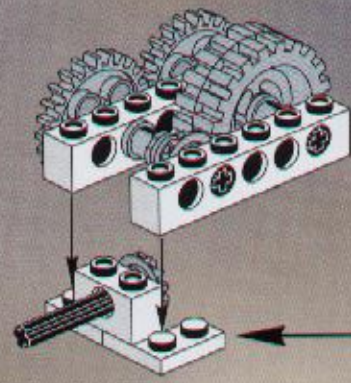
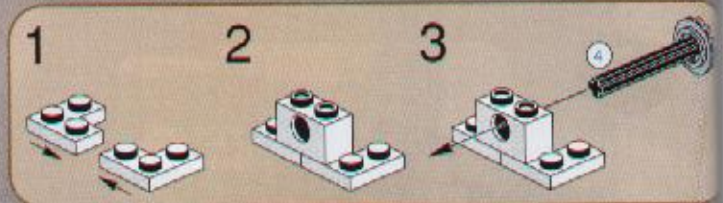
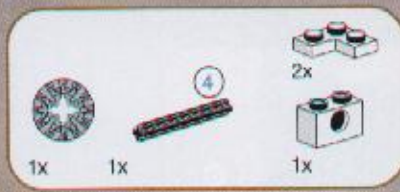

7

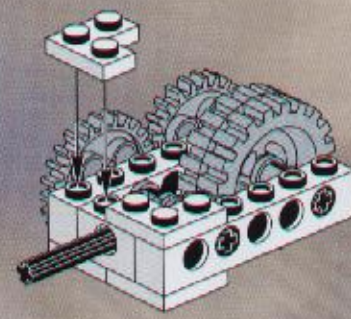

8

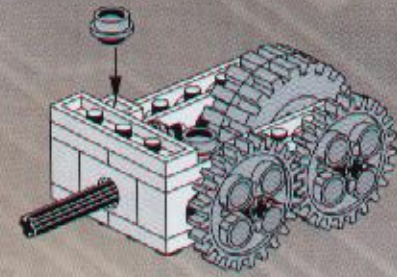
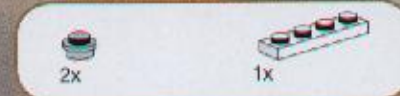

LEGO.com/ideas

9

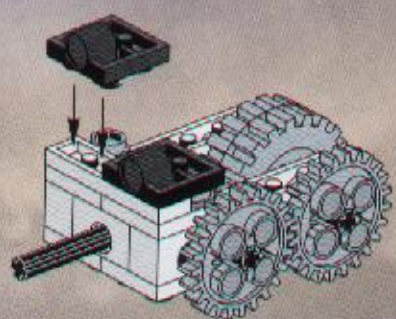

10

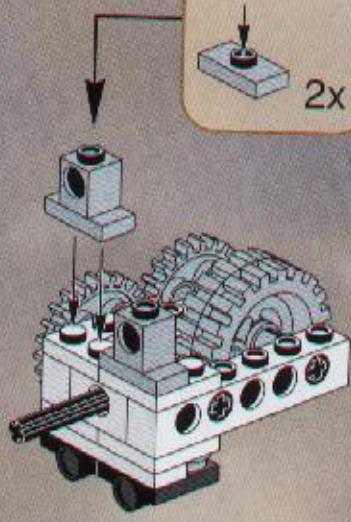
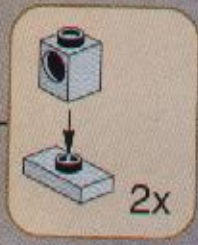
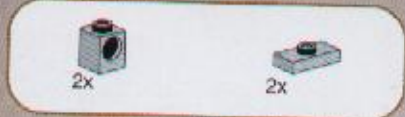

11

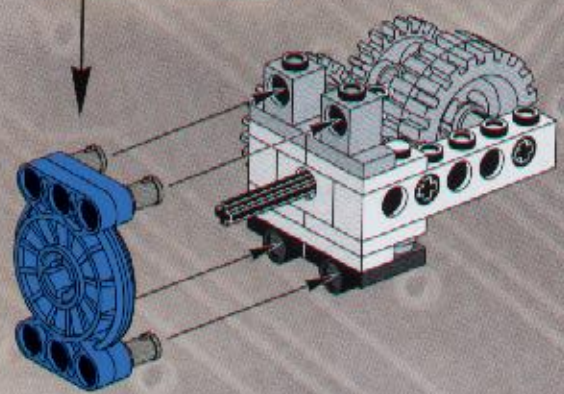
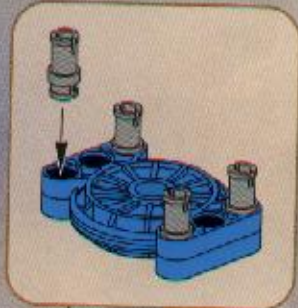
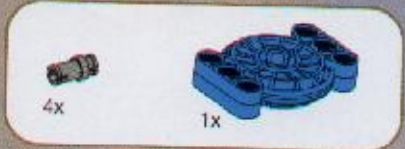



12



4x



2x

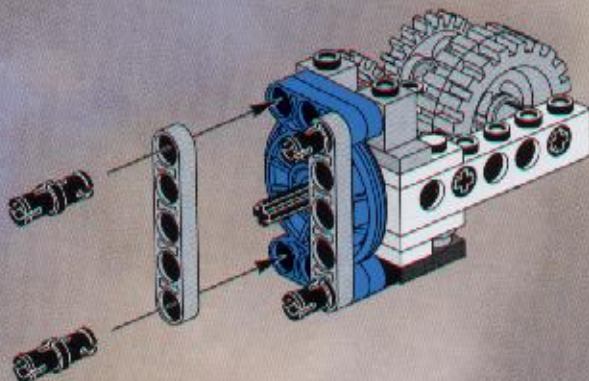

3



2x



2x



2x

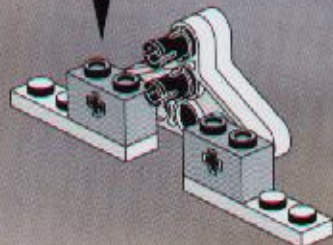

1



2x



2x

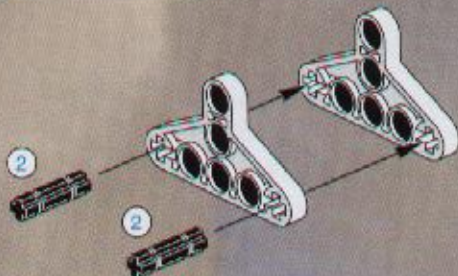

4



2x

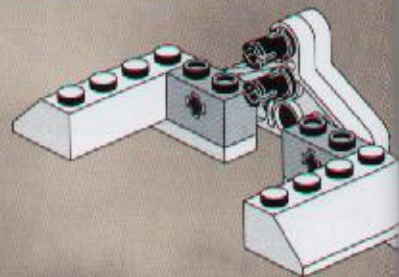

2



2x

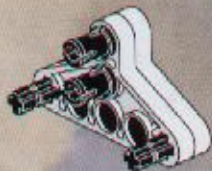

5



2x



1x

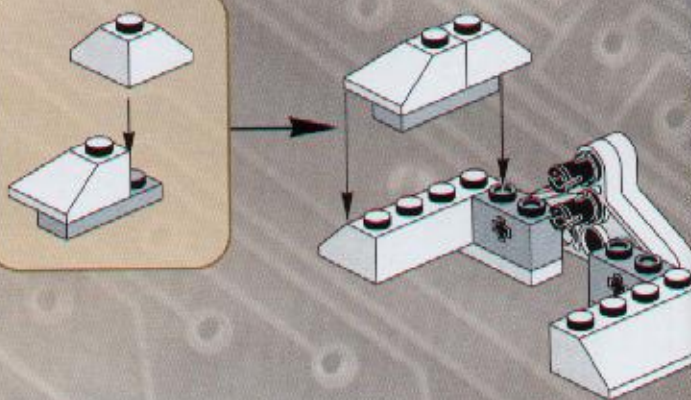
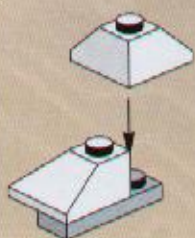

6

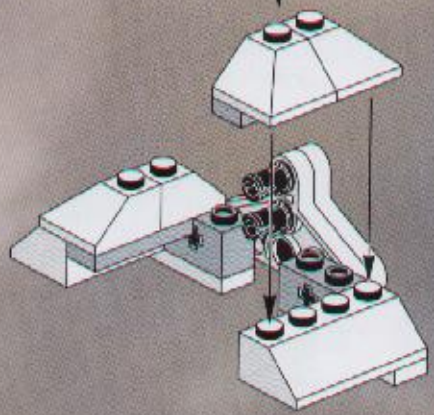
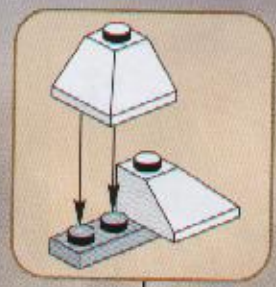
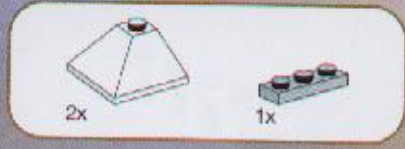

9

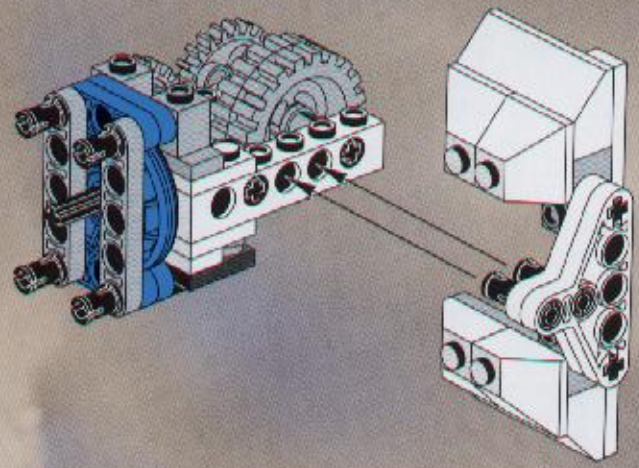

11

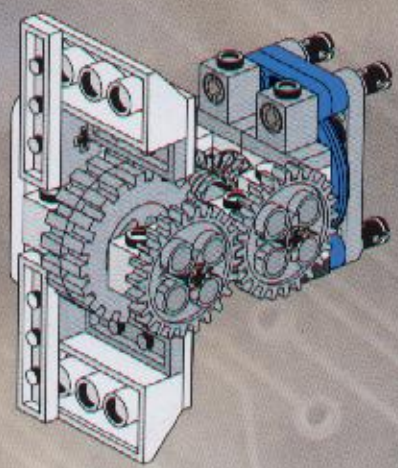



1

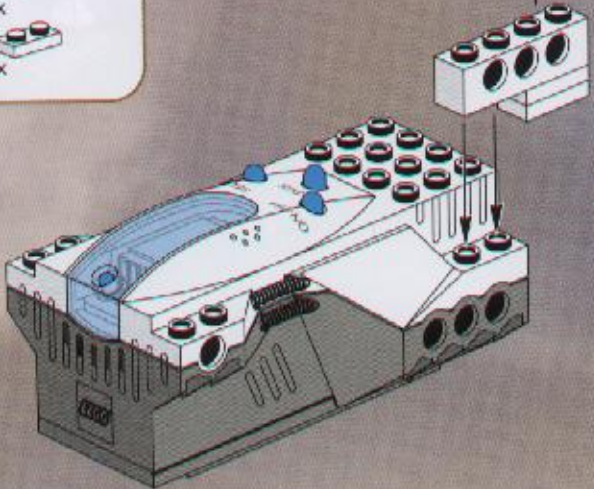
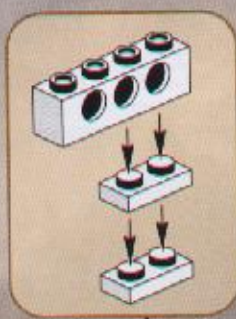
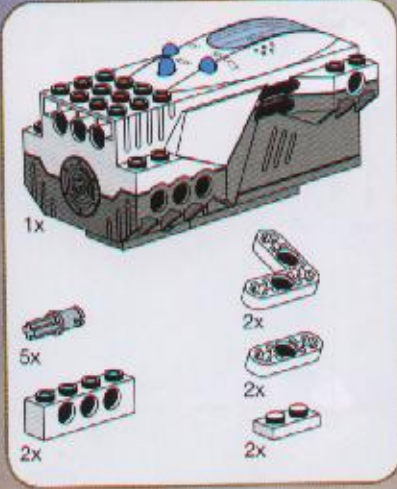

2

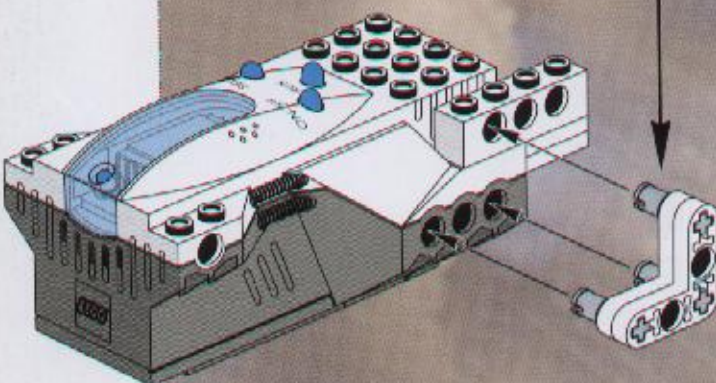
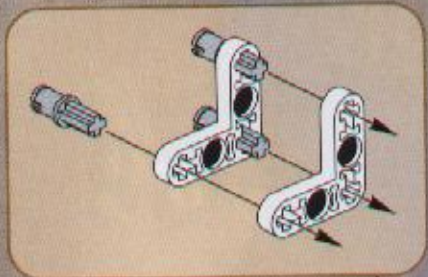

3

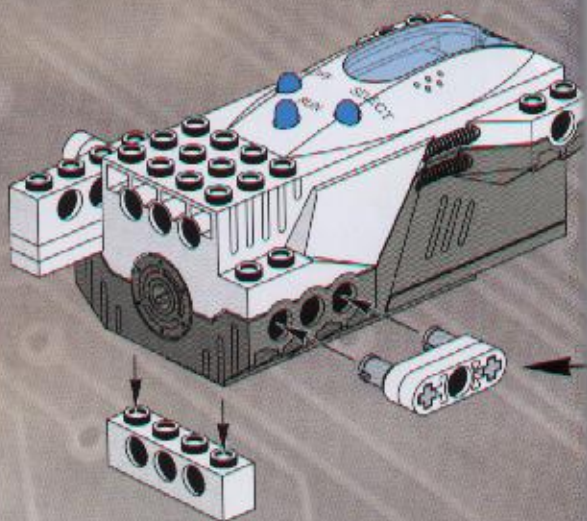
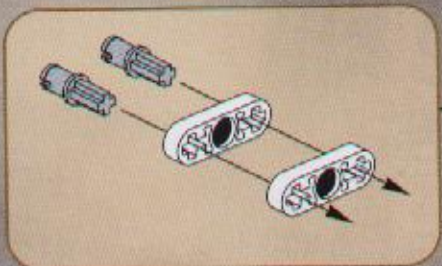

BRUNNEN/LEGO/LEGO



15

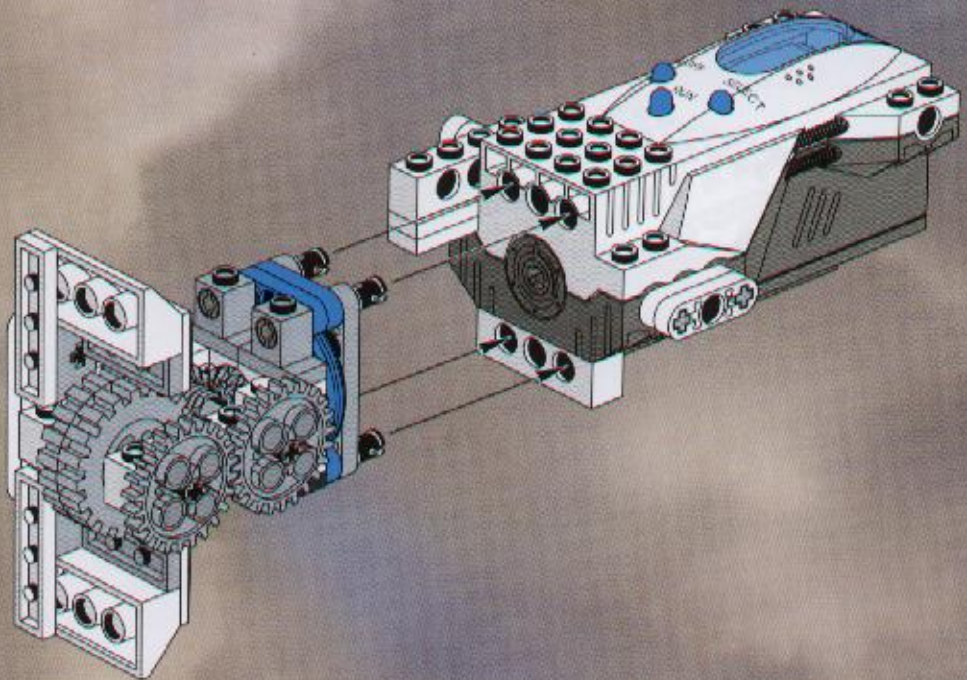

LEGO and the LEGO logo are trademarks of the LEGO Group. © 2008 LEGO Group. All rights reserved.



1

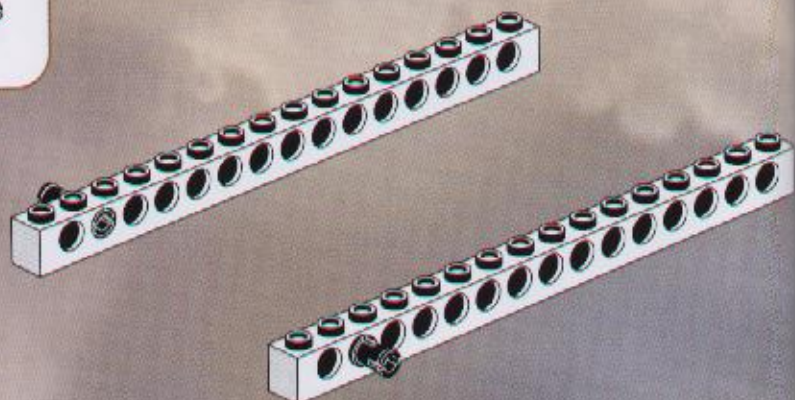
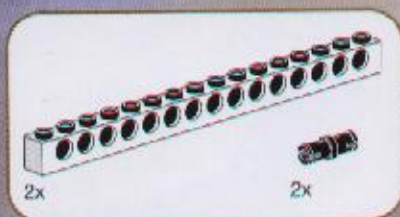

2

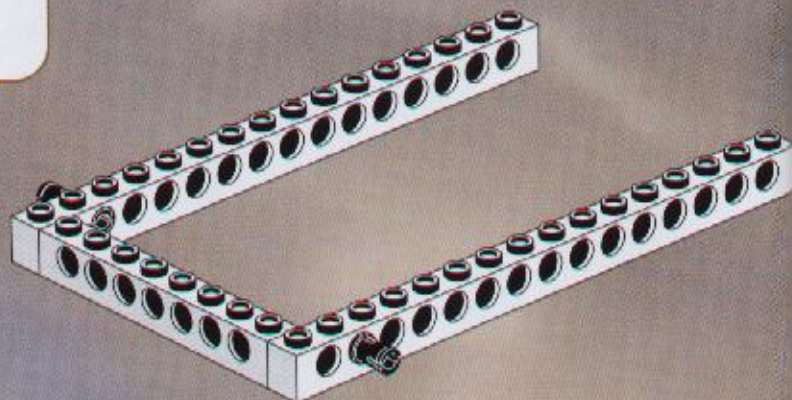
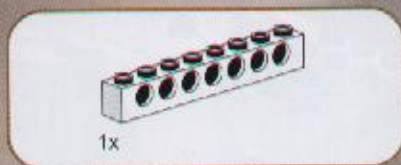

3

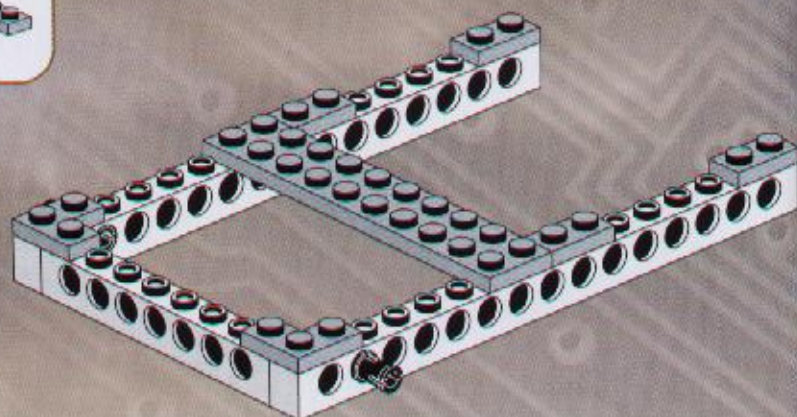
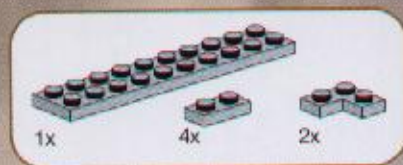

4

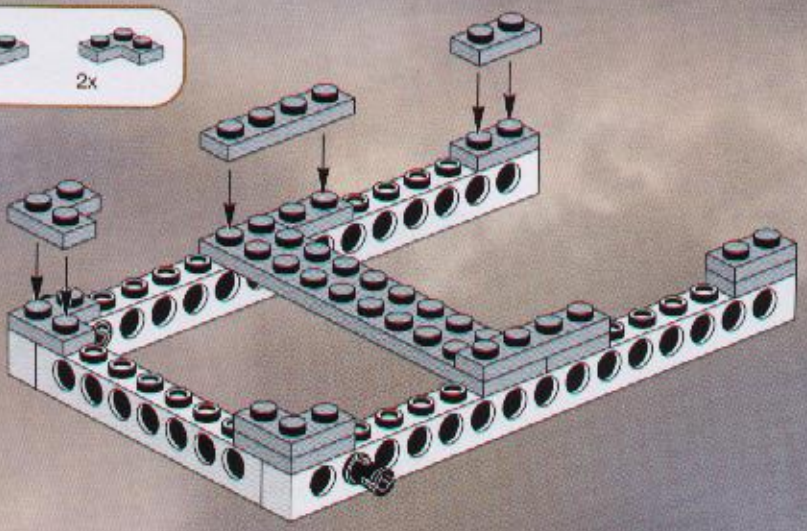

5

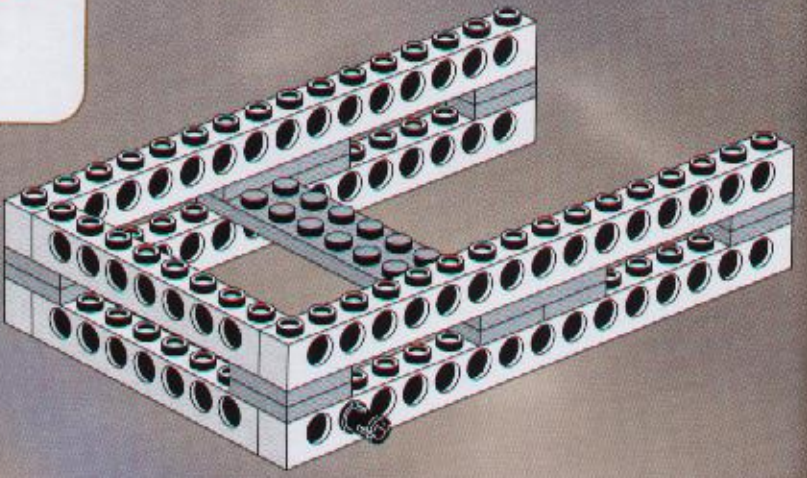
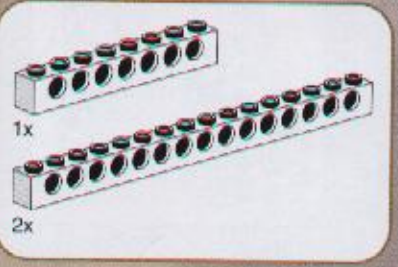

6

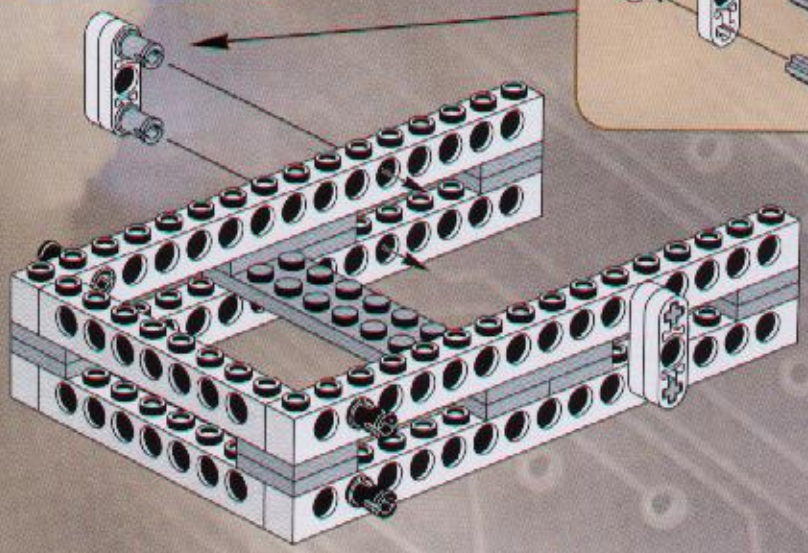
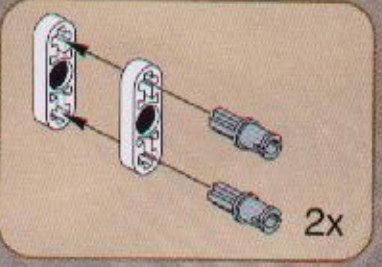



7

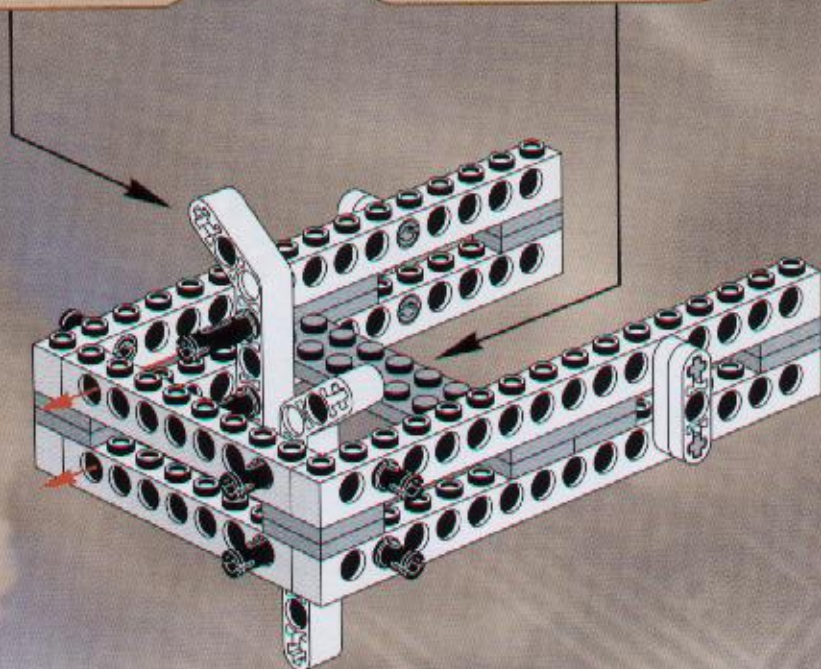
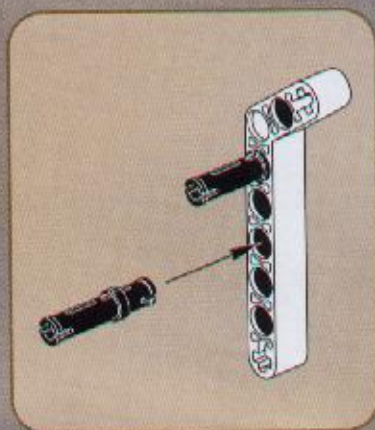
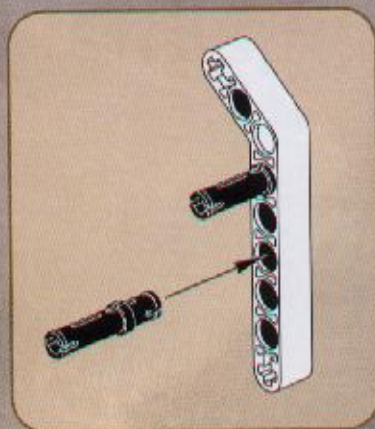
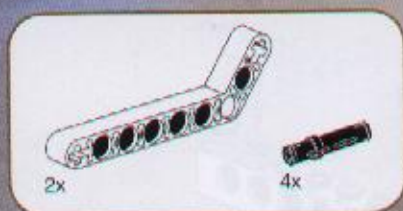

8

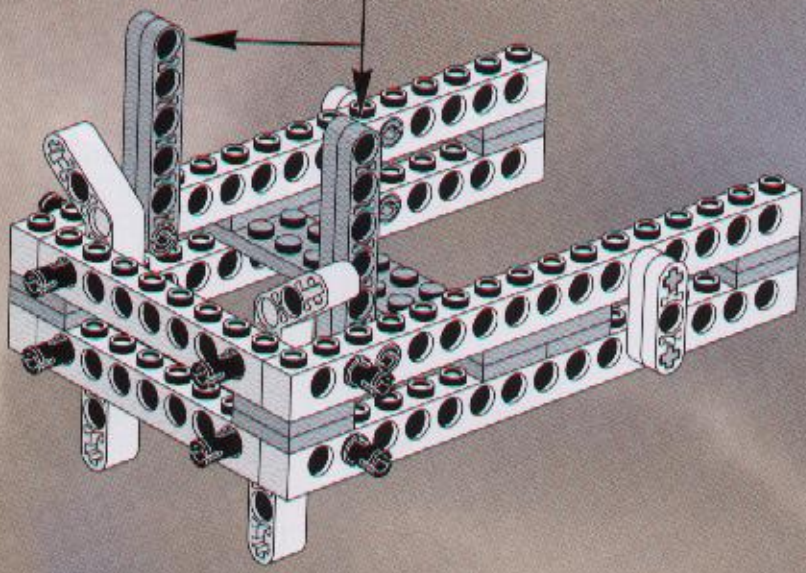
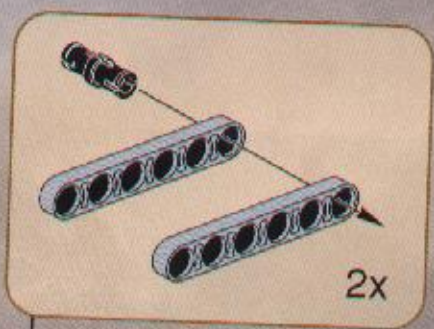

9

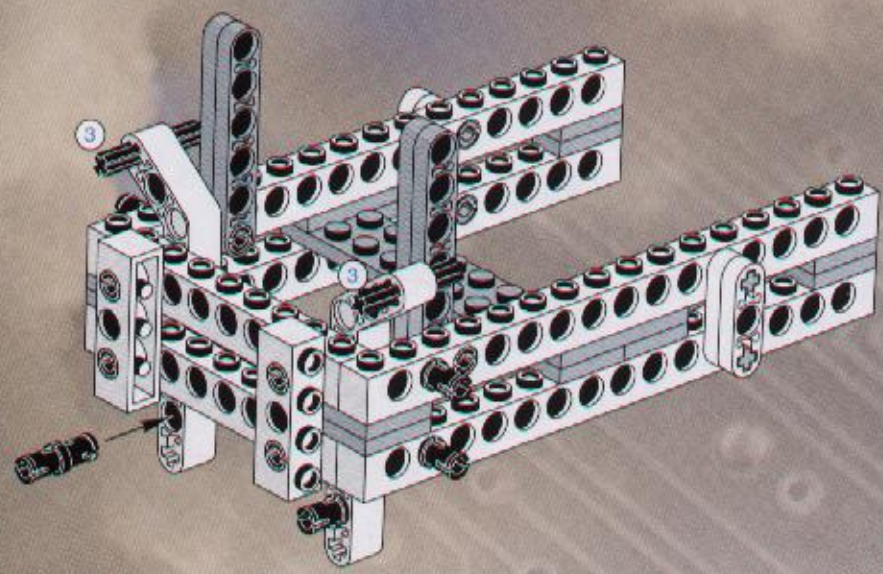
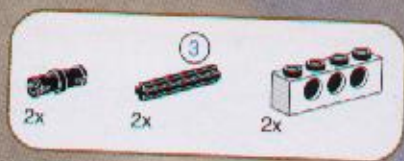



10

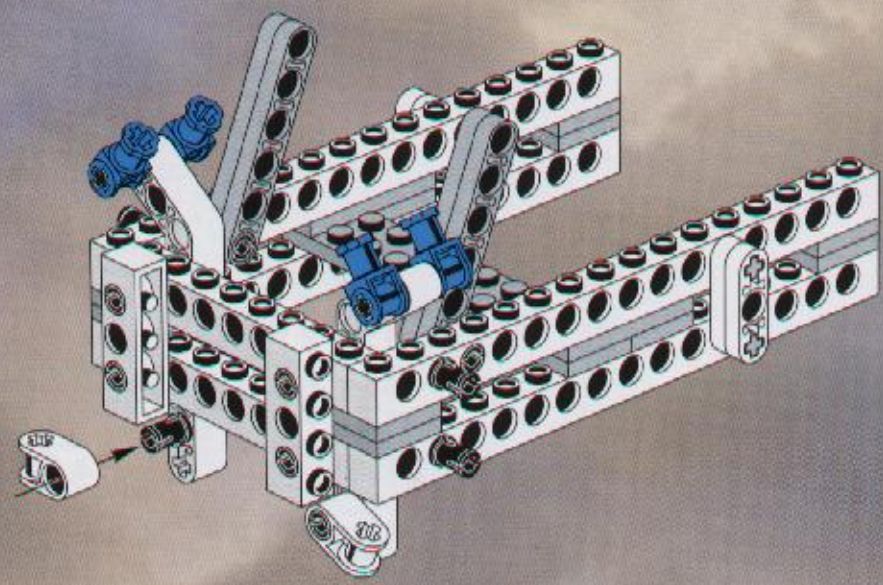

11

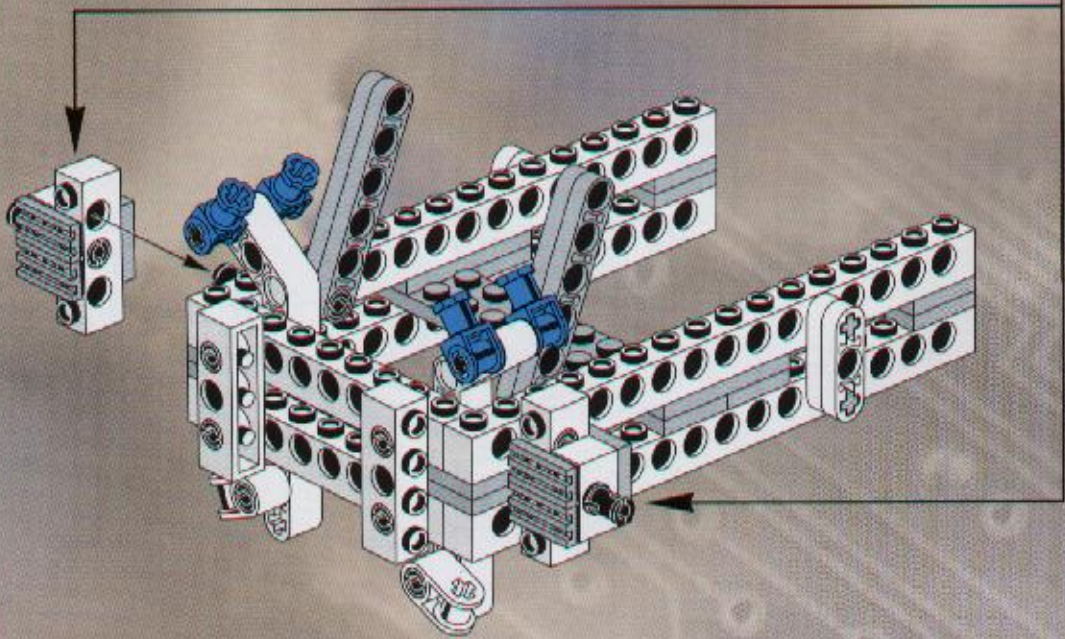
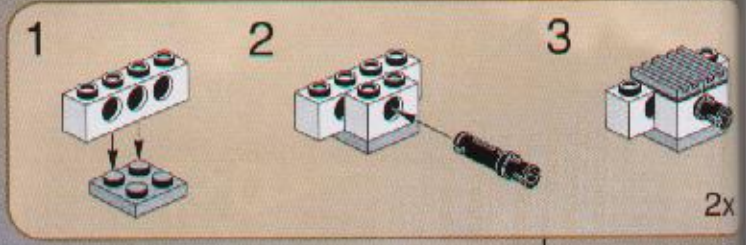
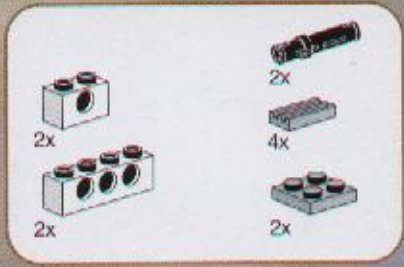

LEGO.com/Manuals/108

12



4x

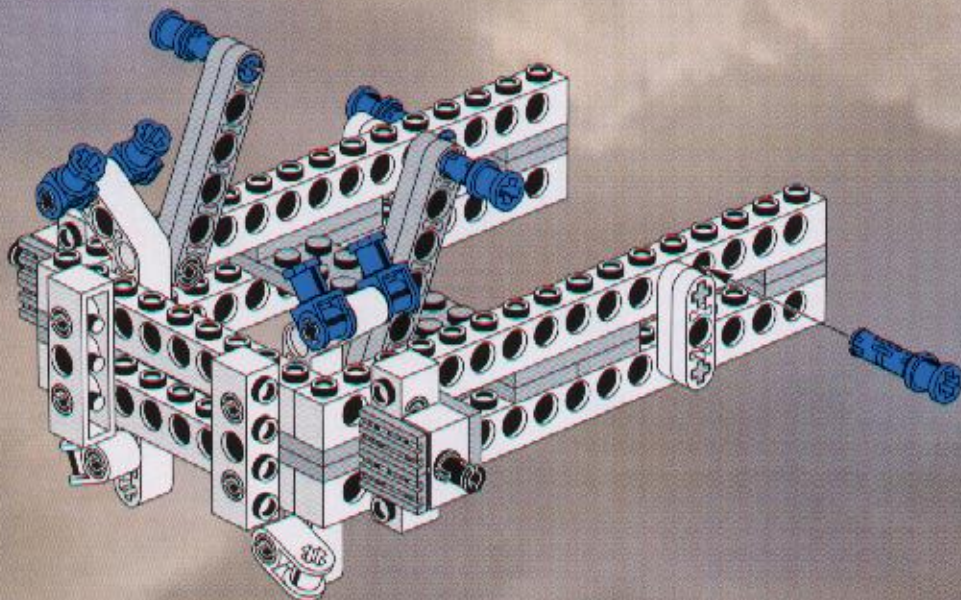

13



1x



2x



6x



2x

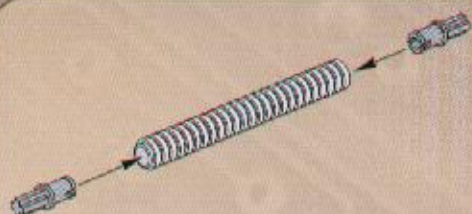
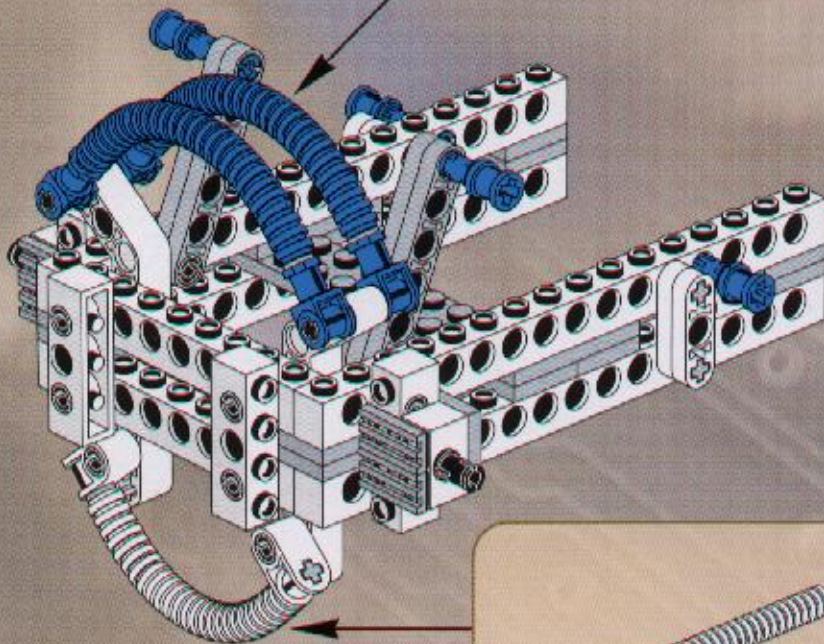



14

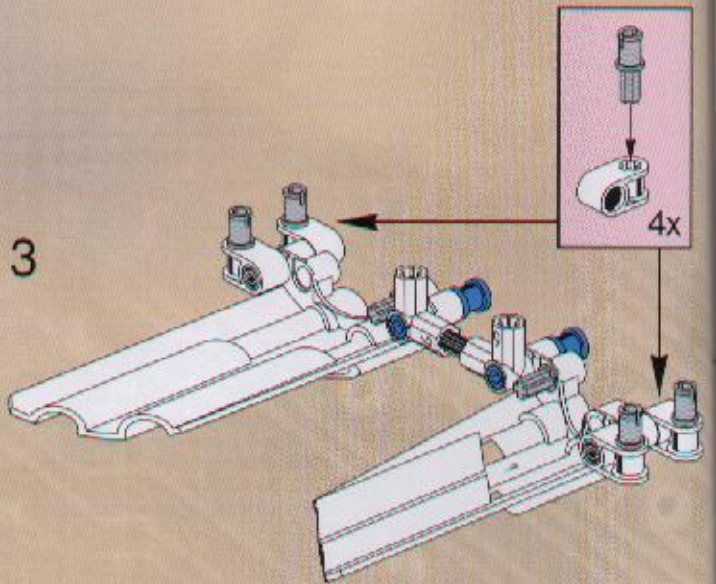
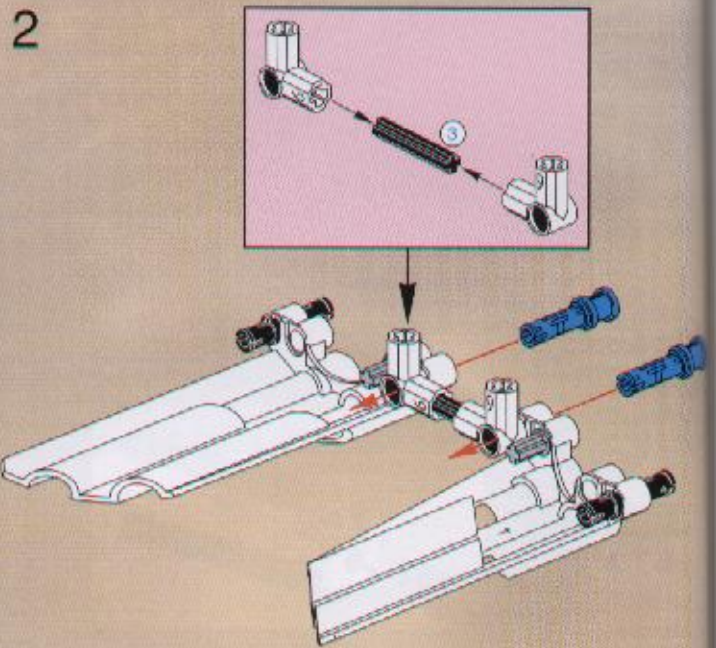
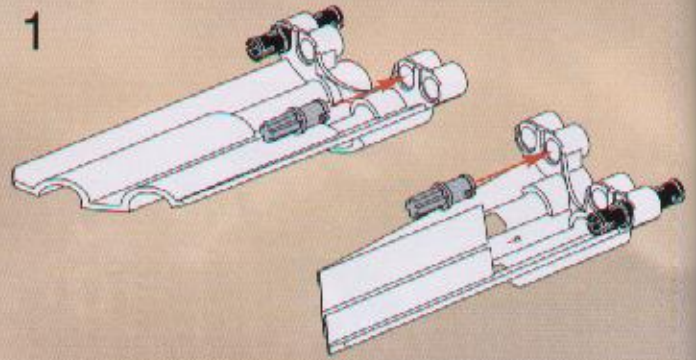
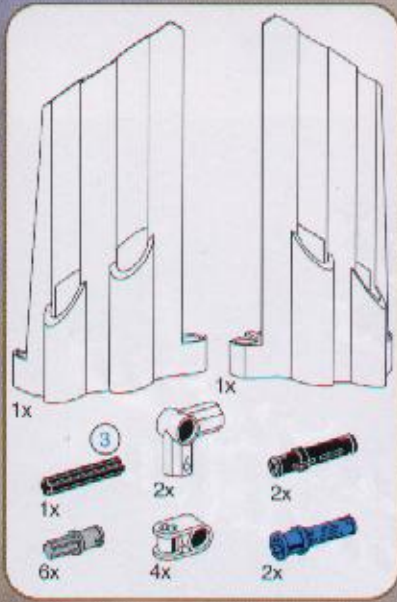

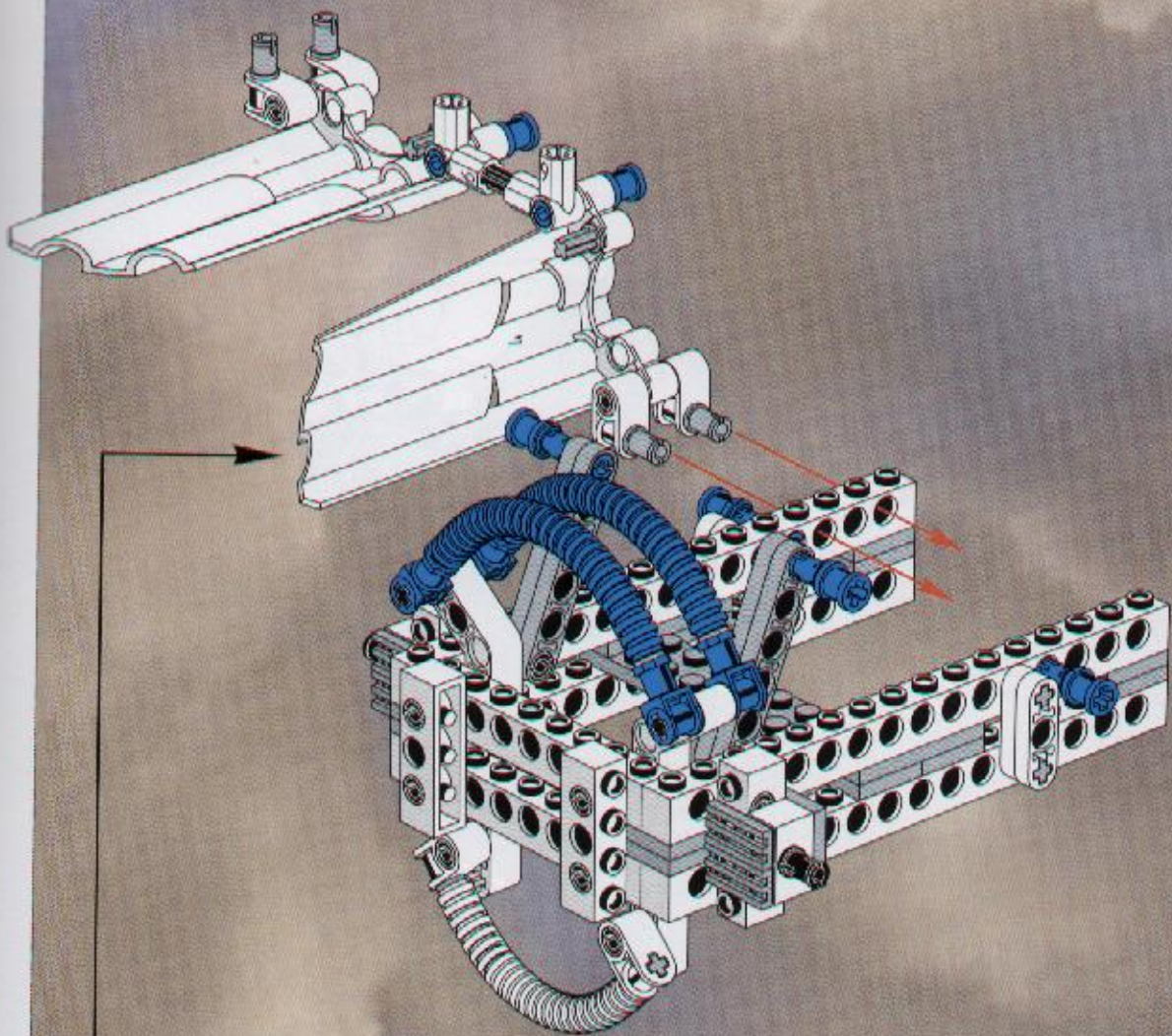



15

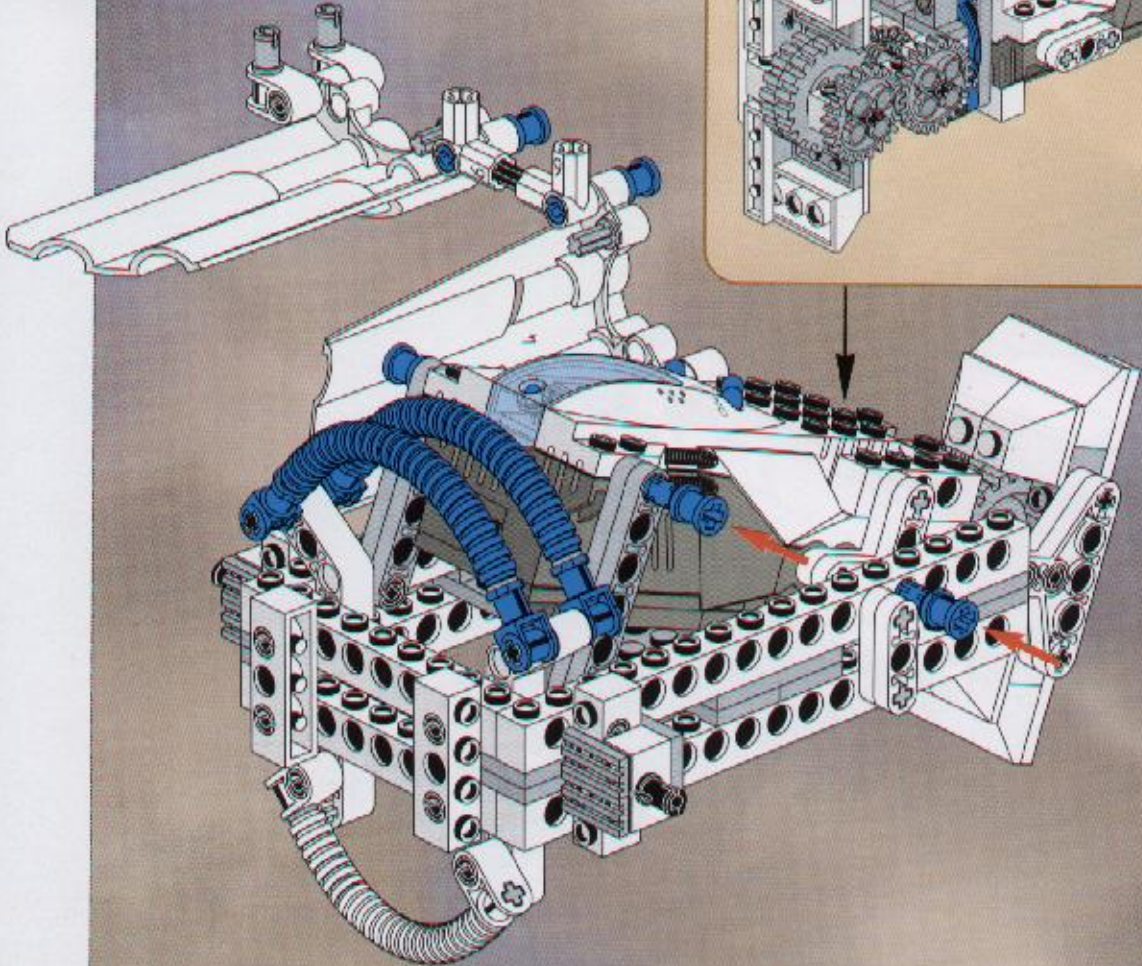
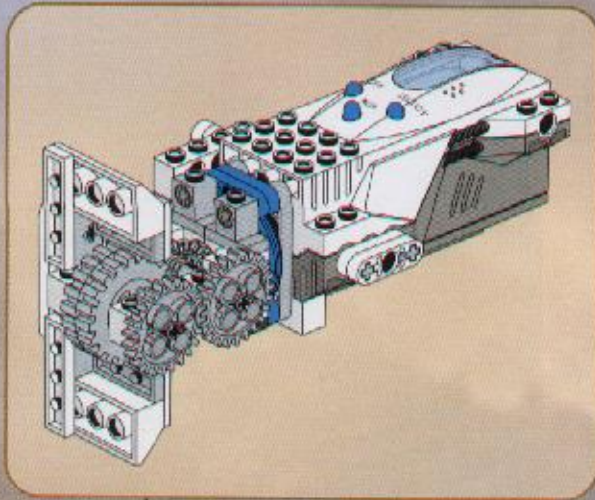

16

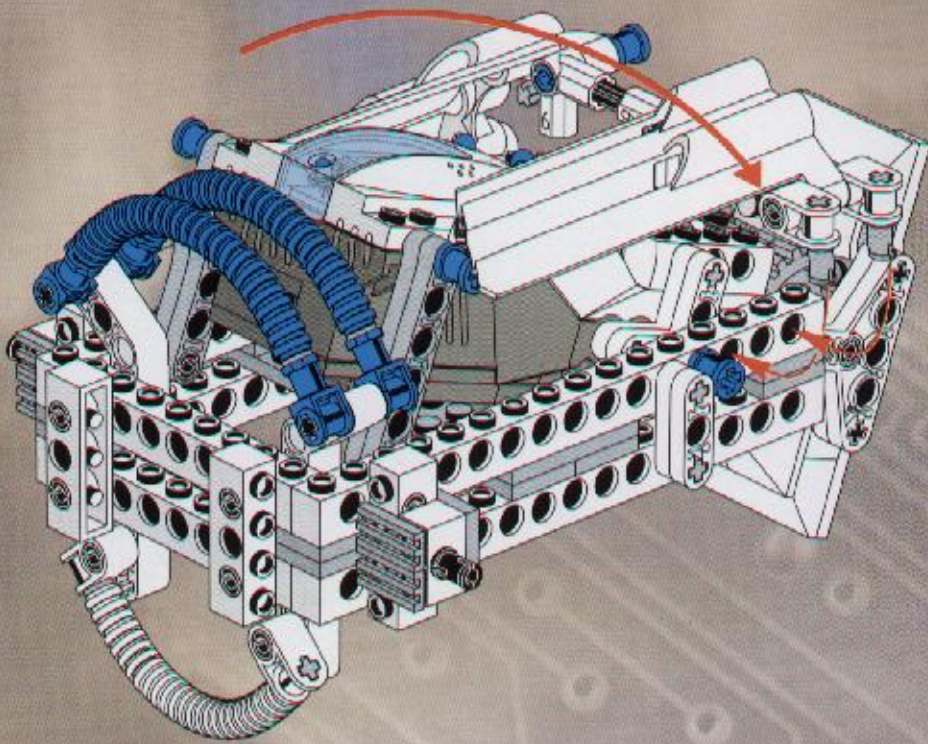

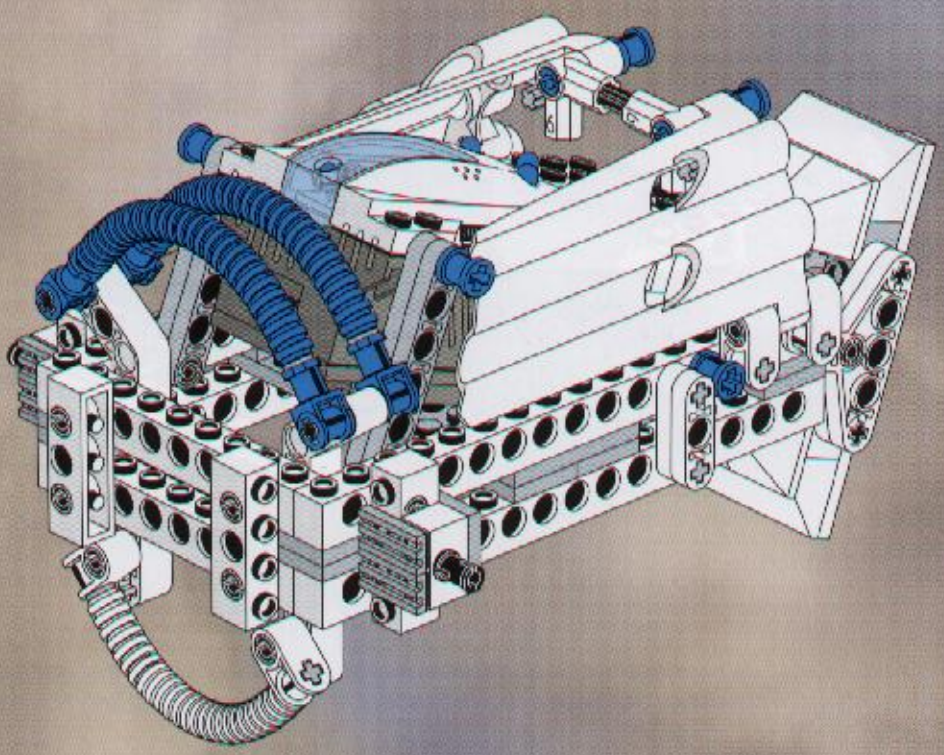



1

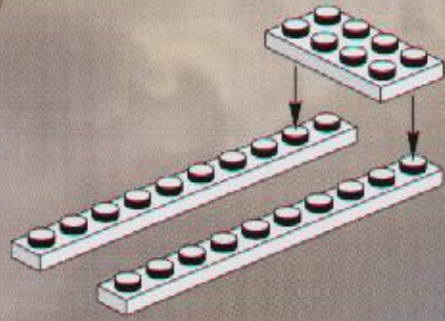
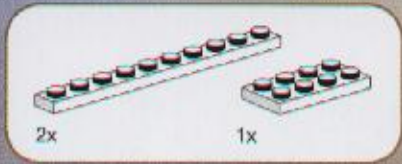

2

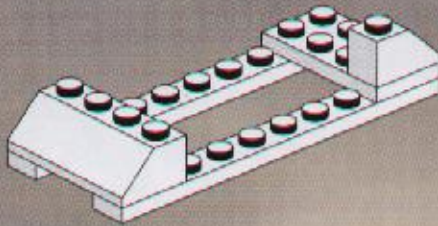
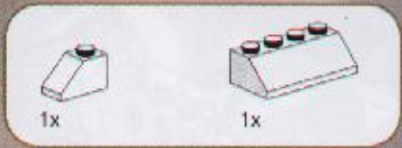

3

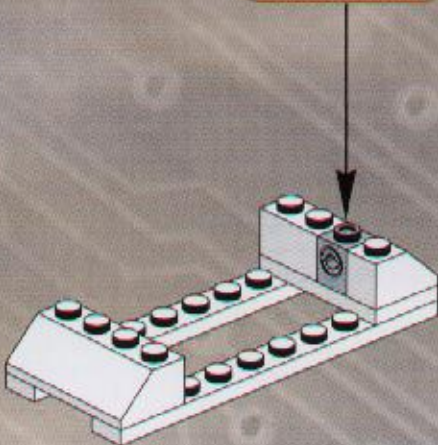
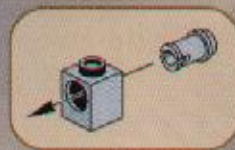

LEGO MINDSPRINGS

4

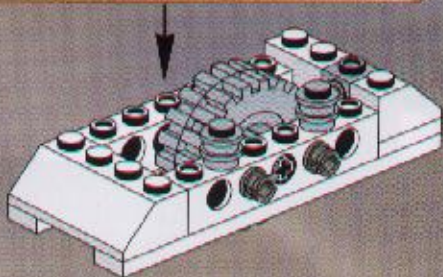
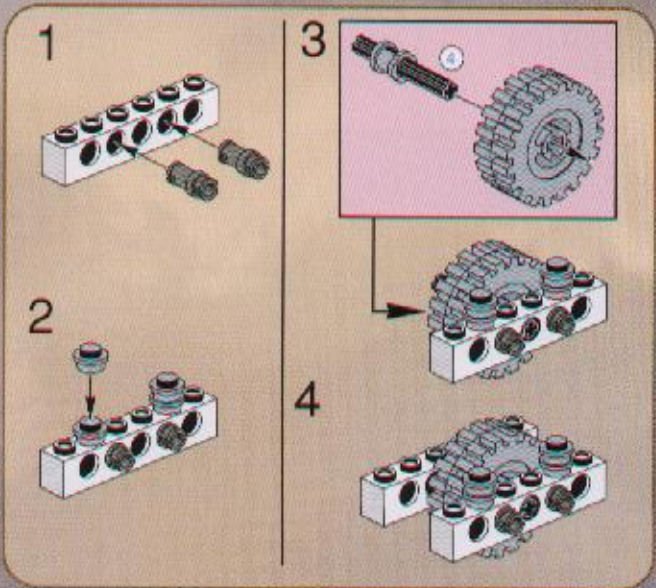
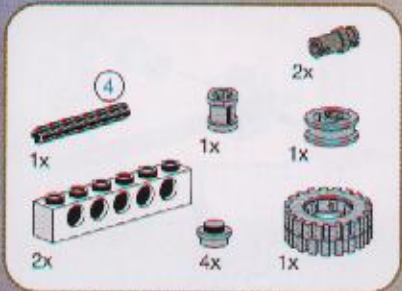

5

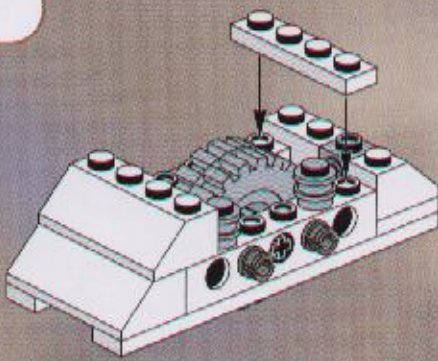
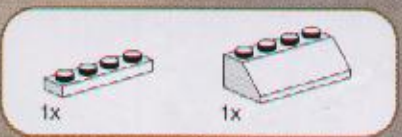

6

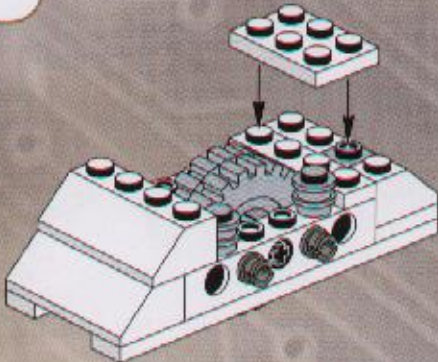

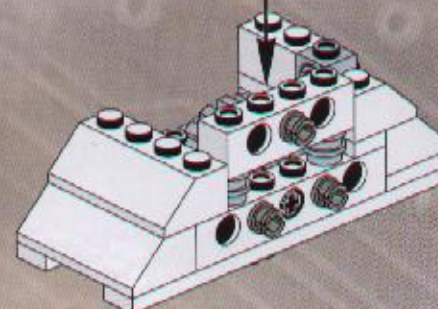
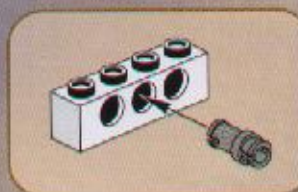
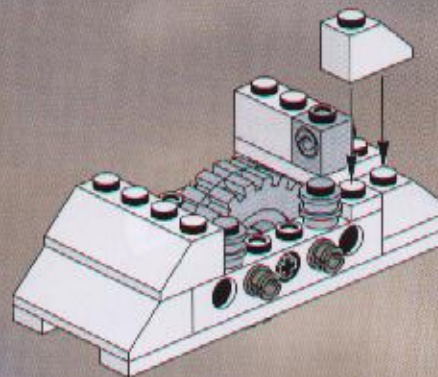
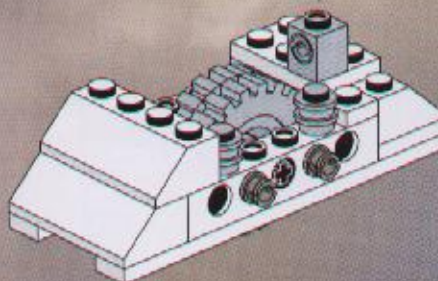
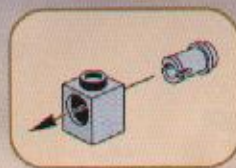

BOHNAVAHATCSUETI

10

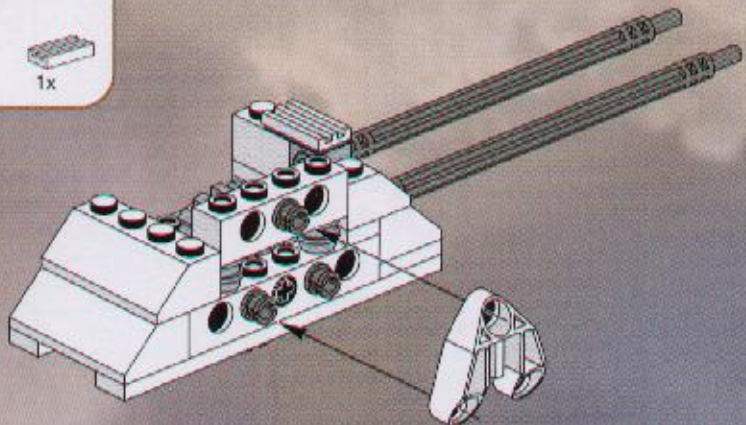
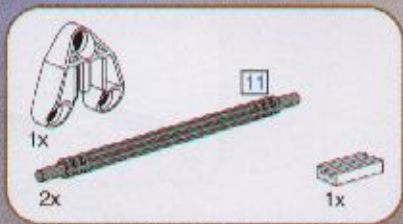

1



4

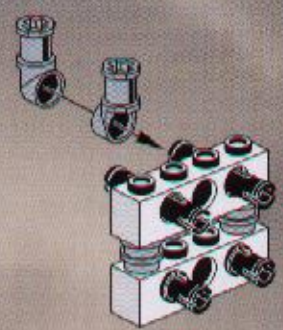

2



5

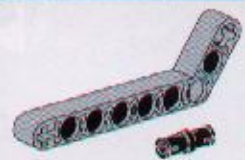
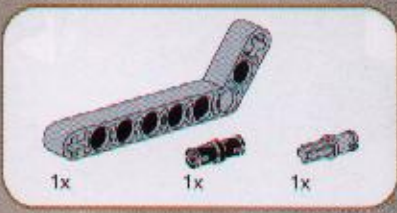

3

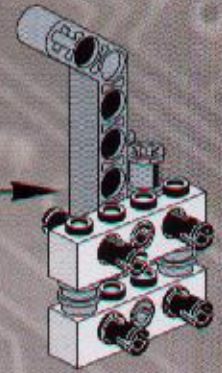
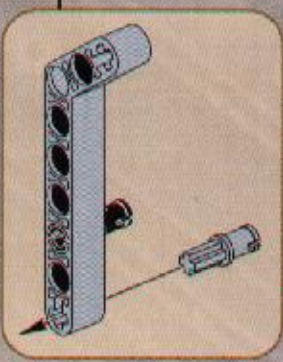
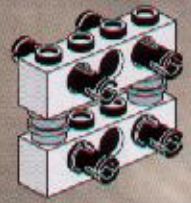
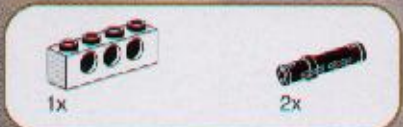



6

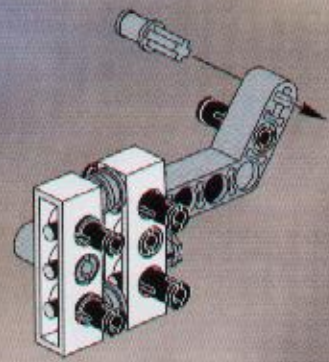

7

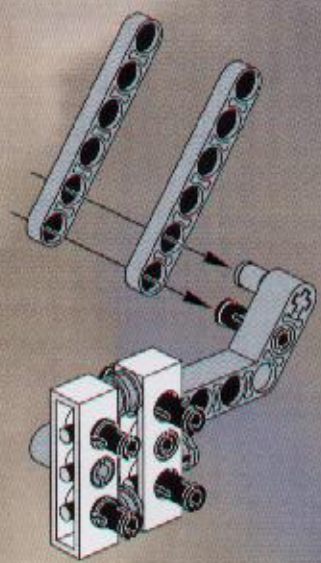

8

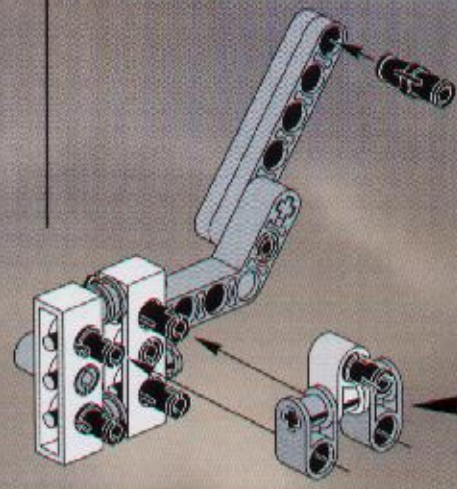
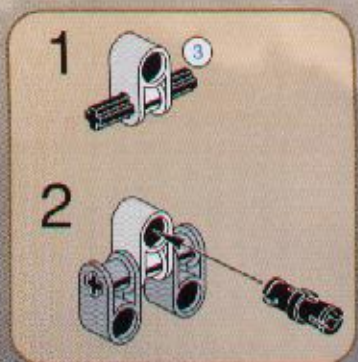

9

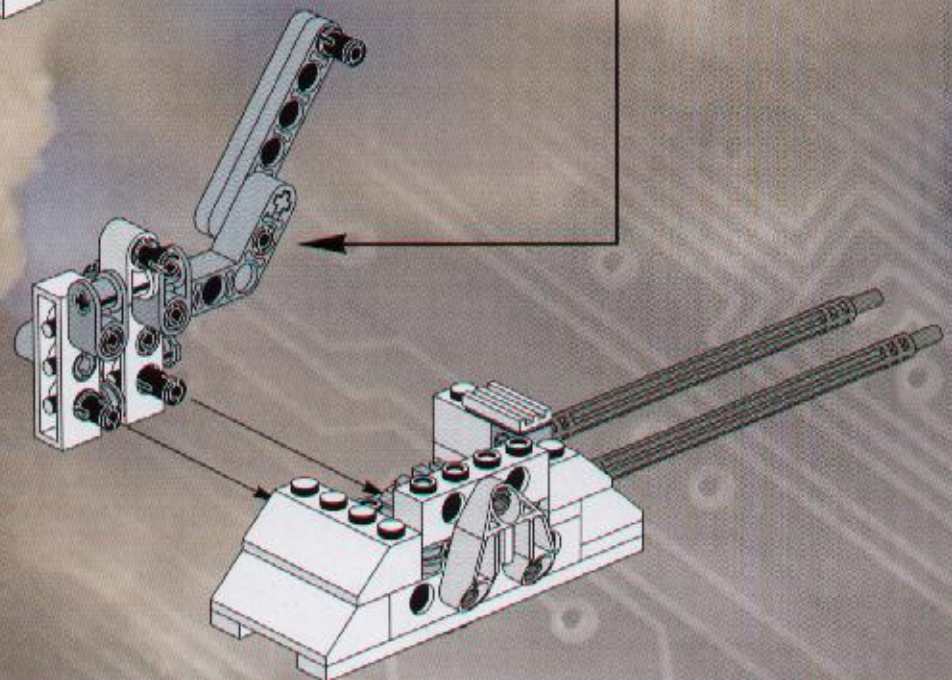

12

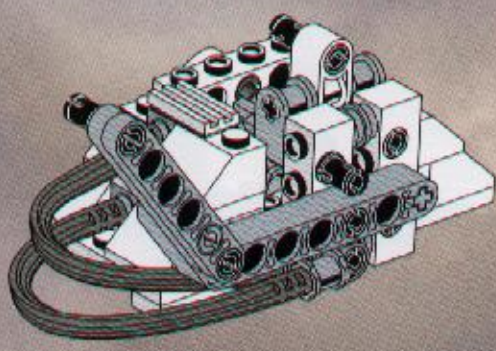

1

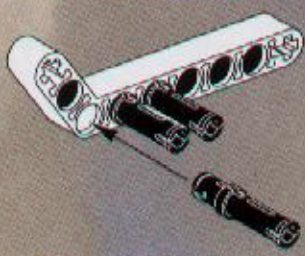
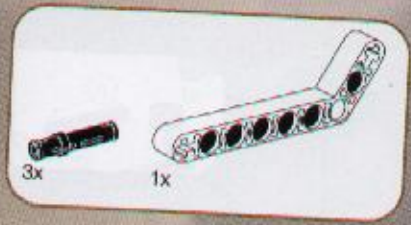

4

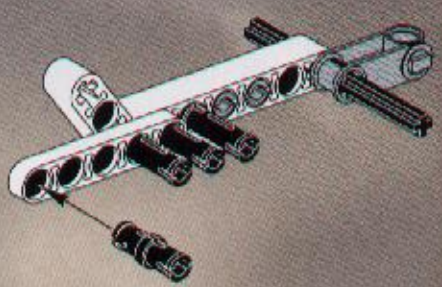

2

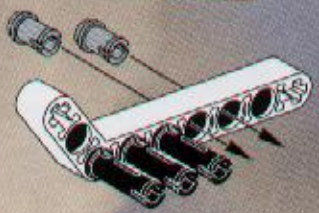

5

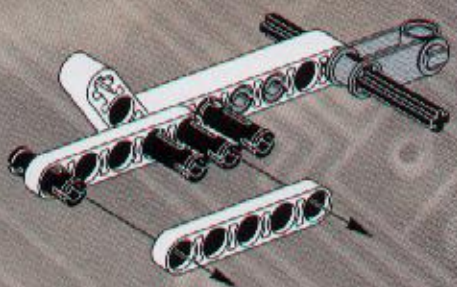

3

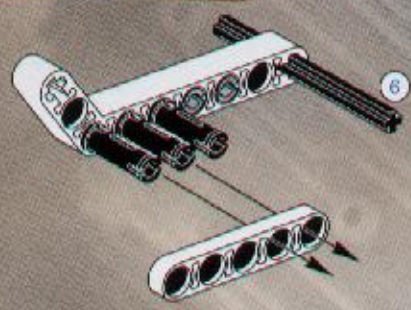



6

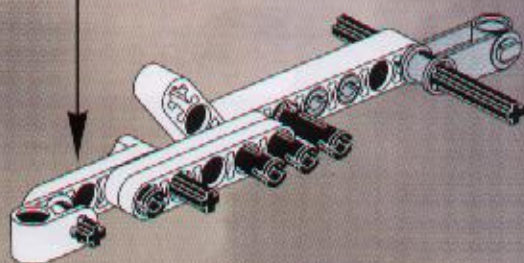
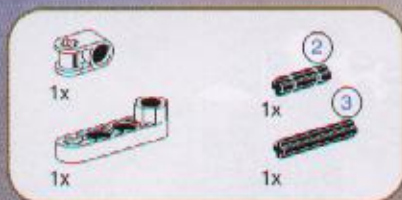

7

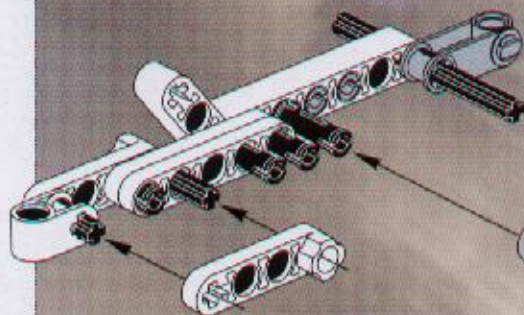
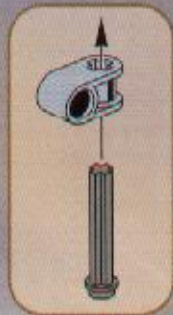
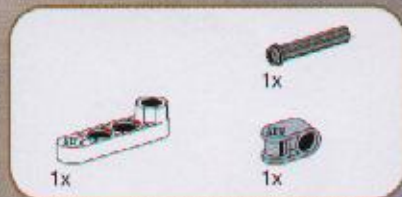

8

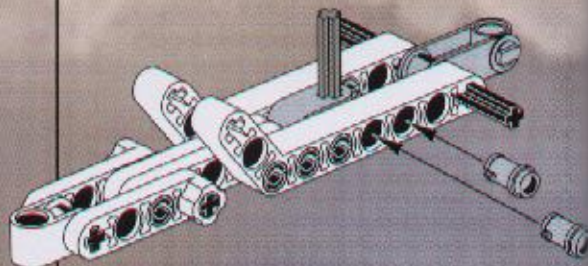
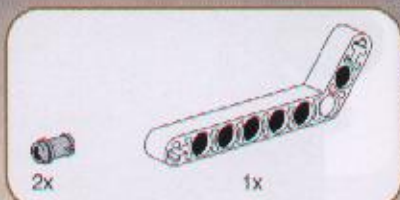

9

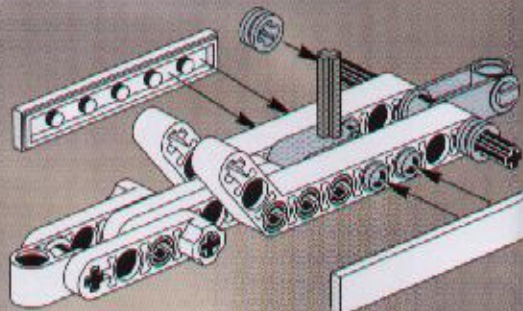
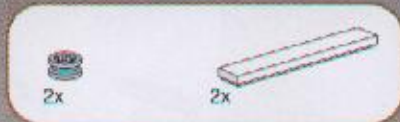

10

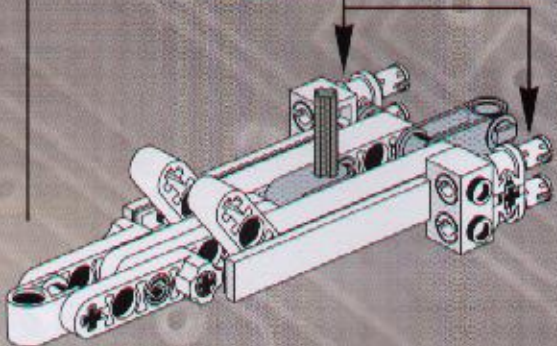
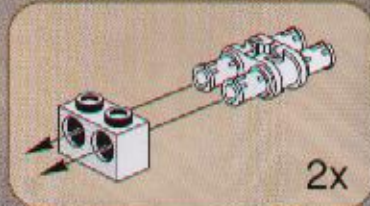
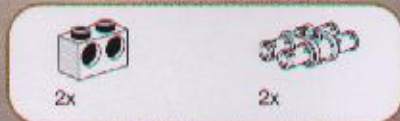

http://www.lego.com

11

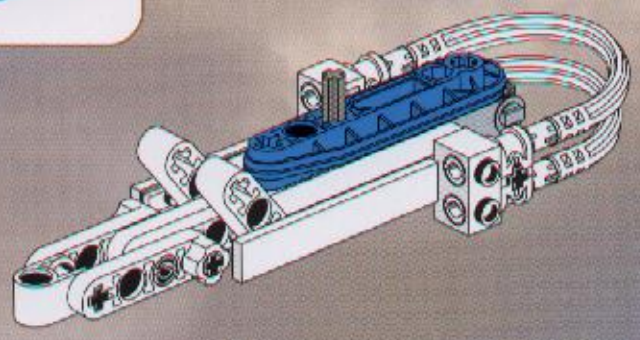

12

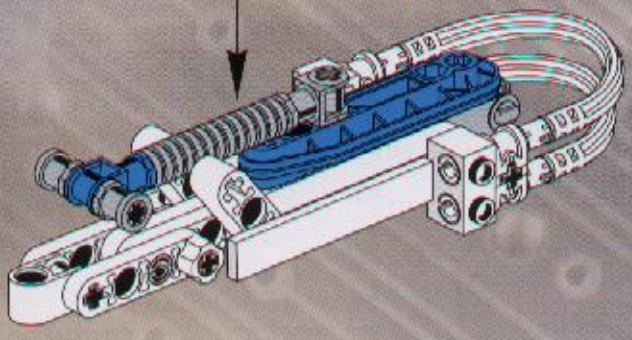
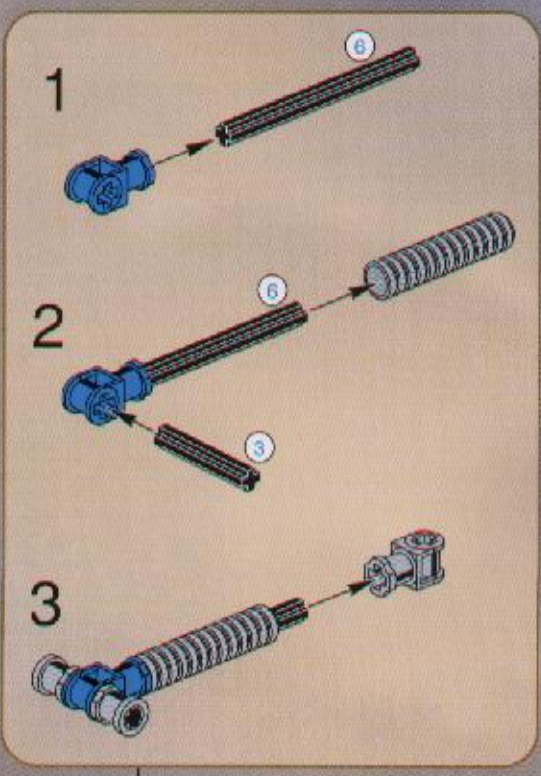
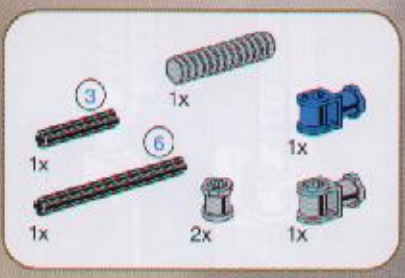



13

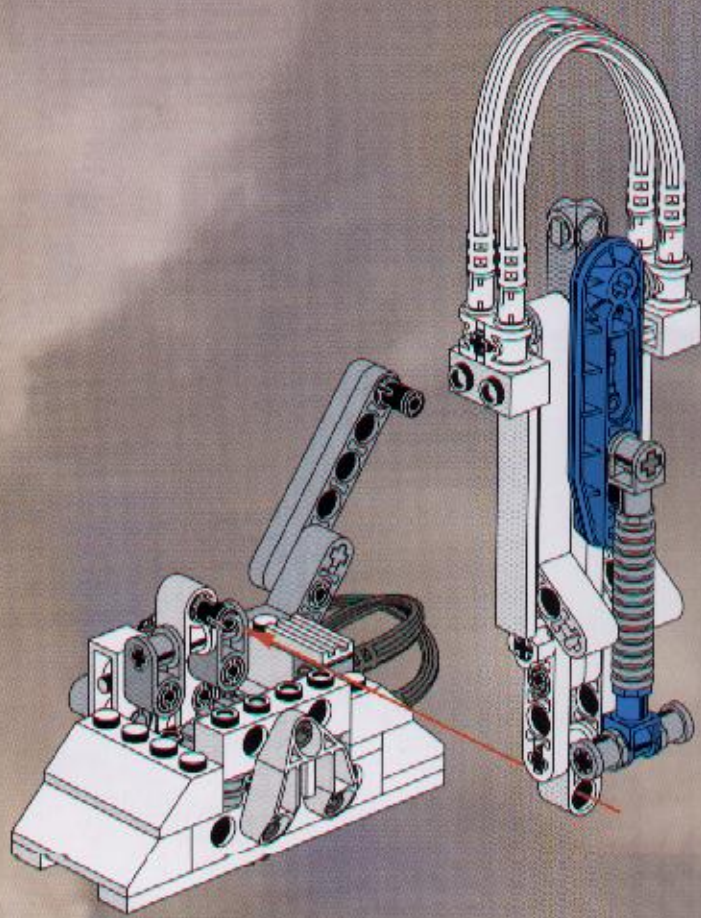

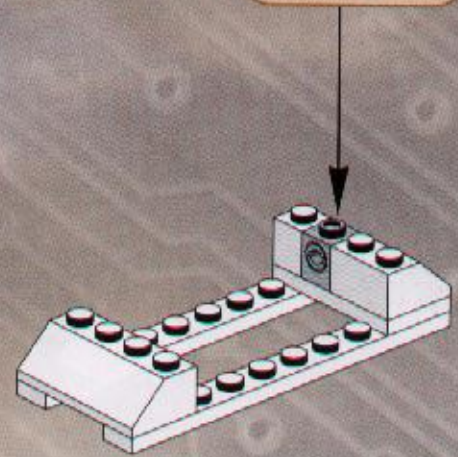
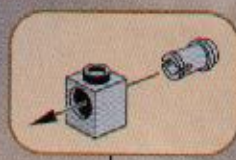
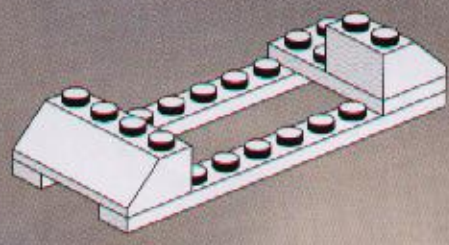
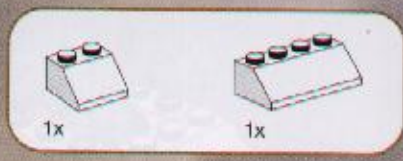
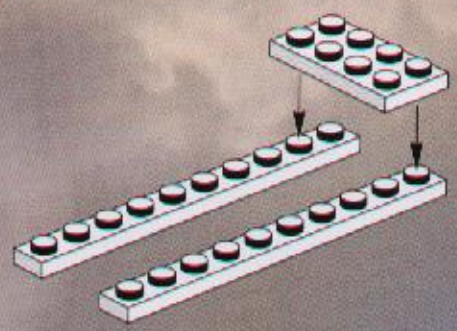
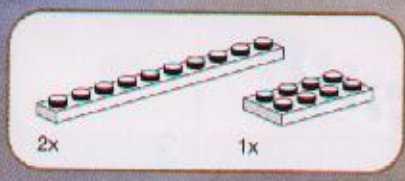



4

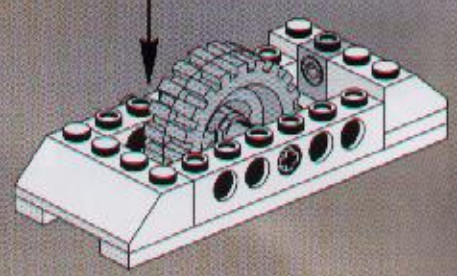
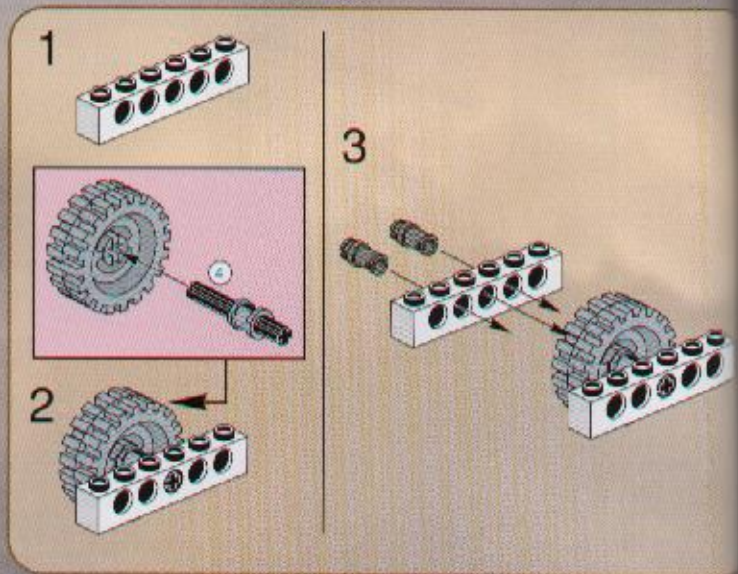
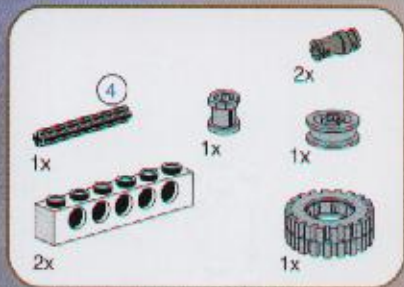

5

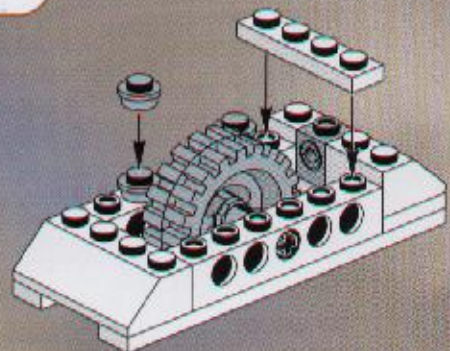

6

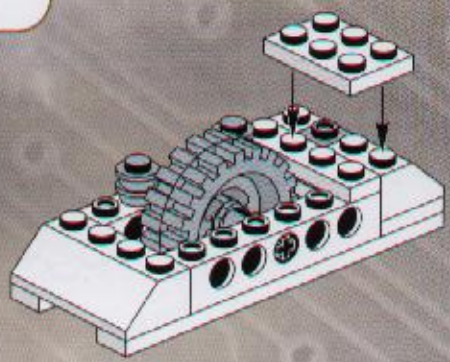

LEGO MINDSTORMS

7

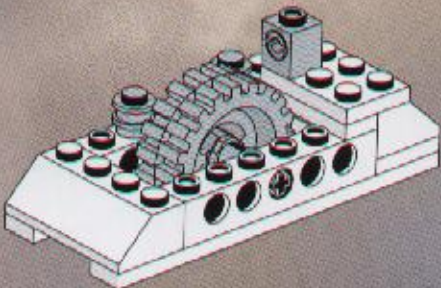
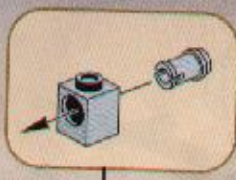

8

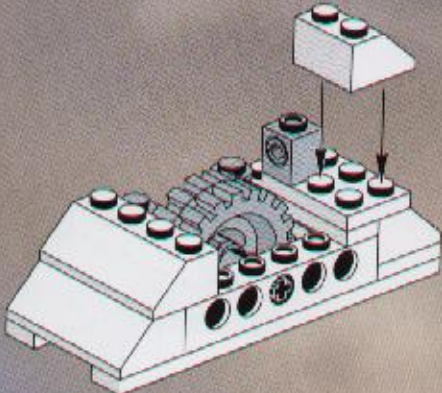
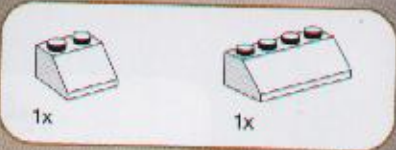

9

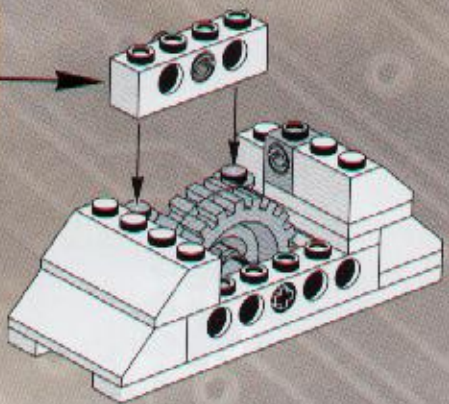
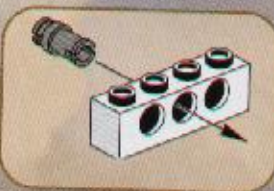



10

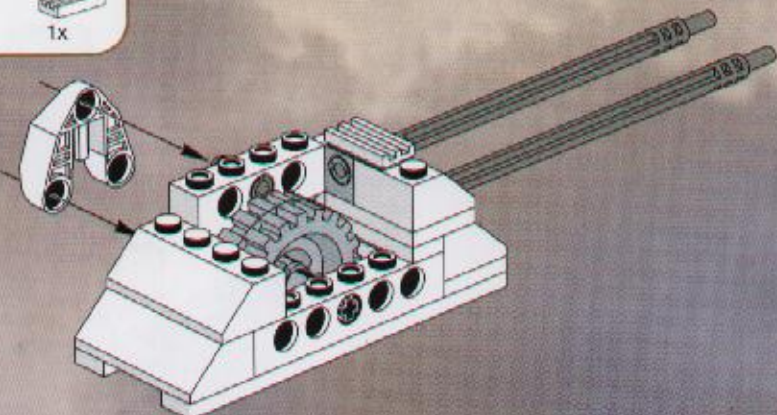
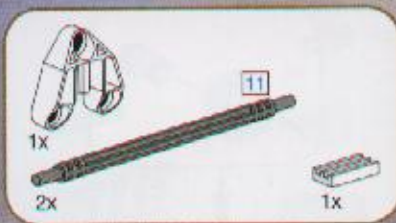

1

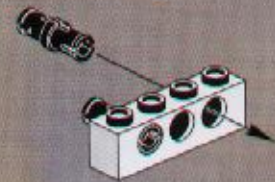

2



3



4

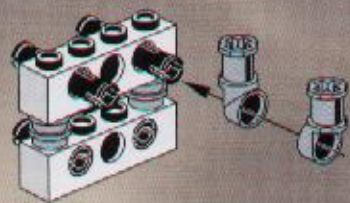

5

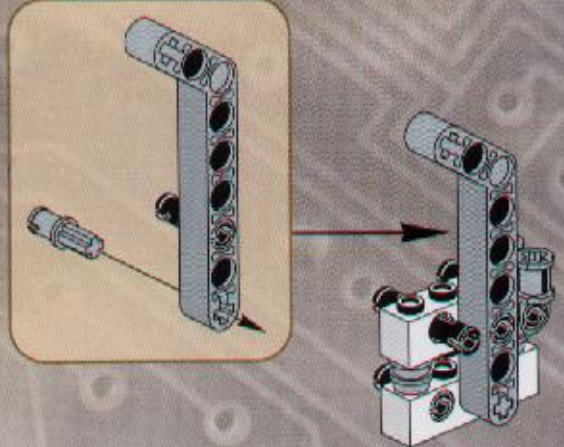
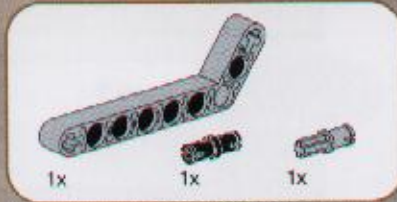

LEGO MINDSTORMS NXT 2.0

6

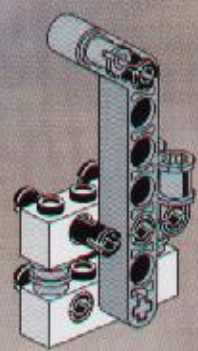
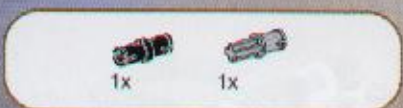

7

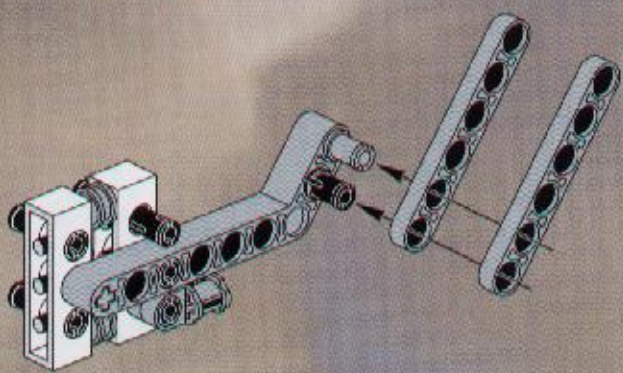

8

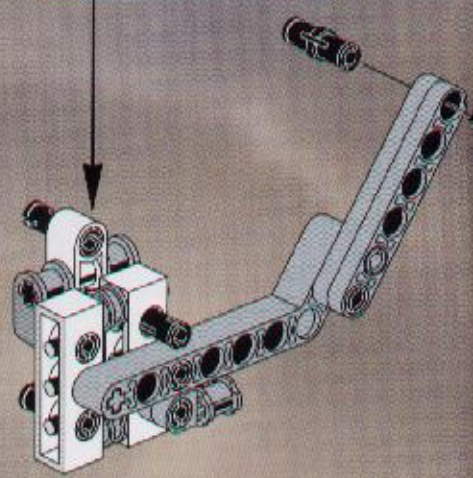
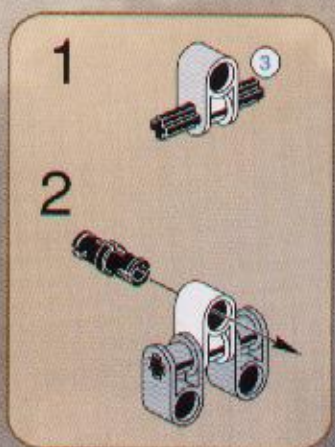

11

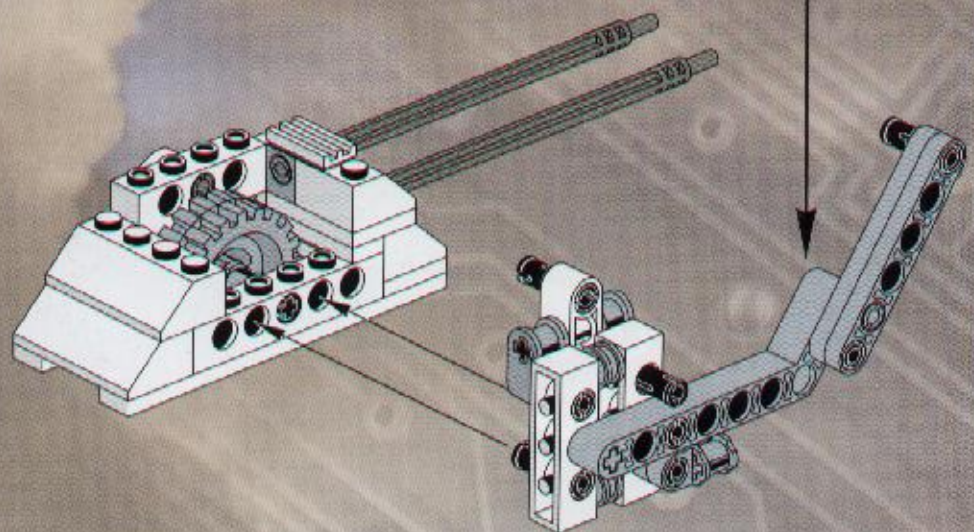



12

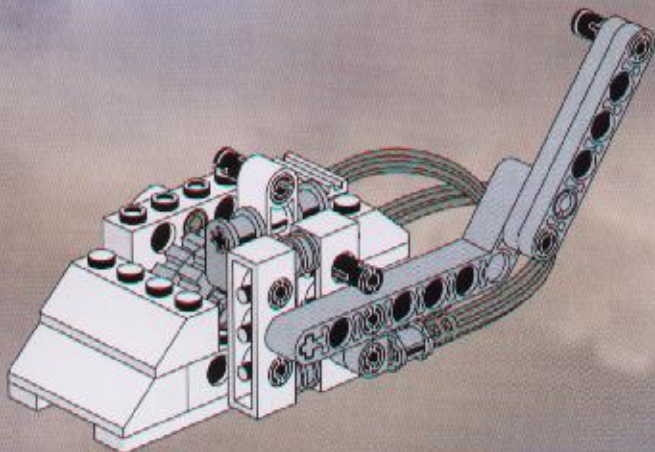

1

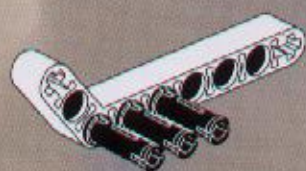
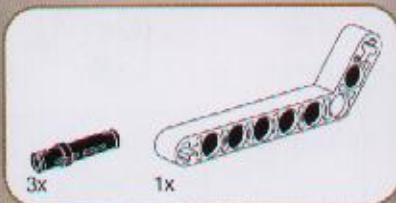

2

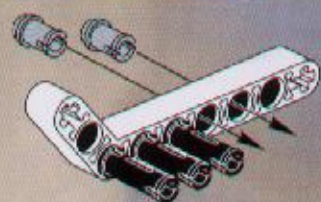

3

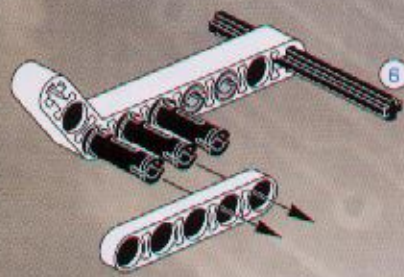

4

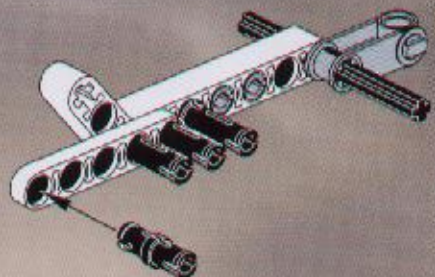
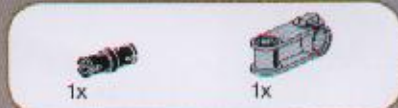

5

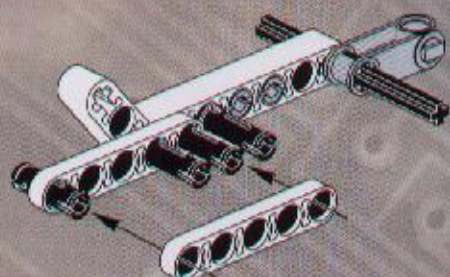

6

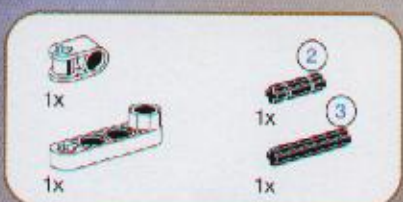

8

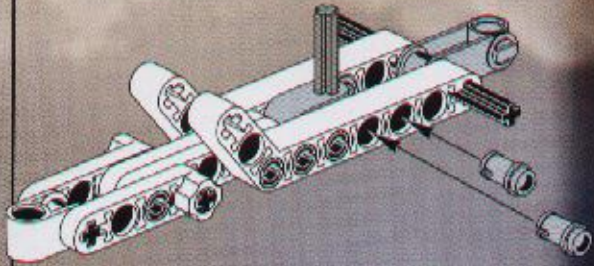
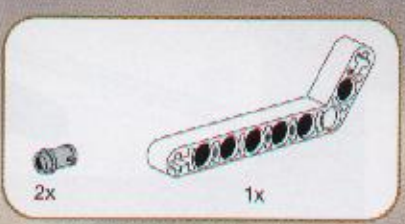

9

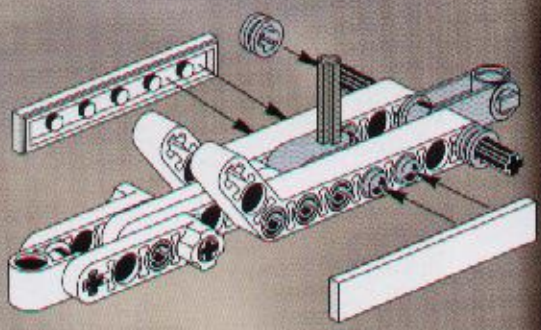

7

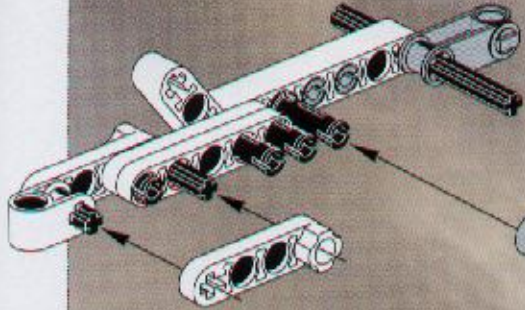
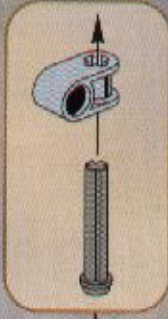
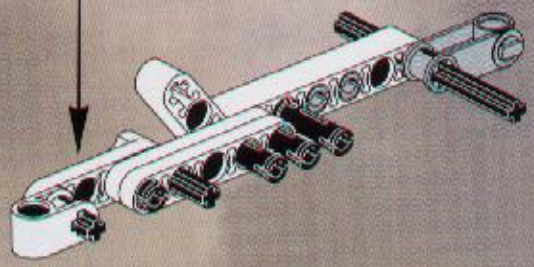
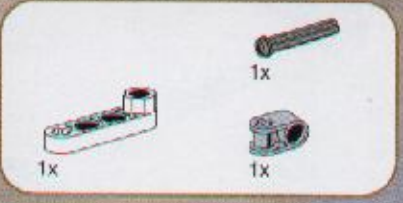

10

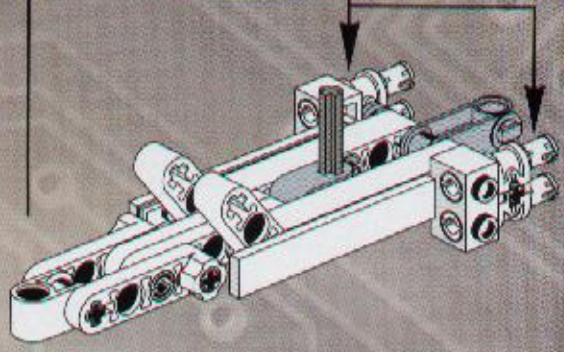
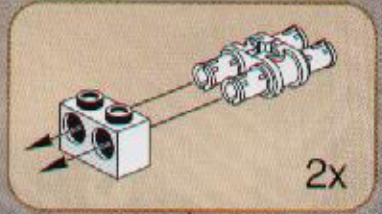



11

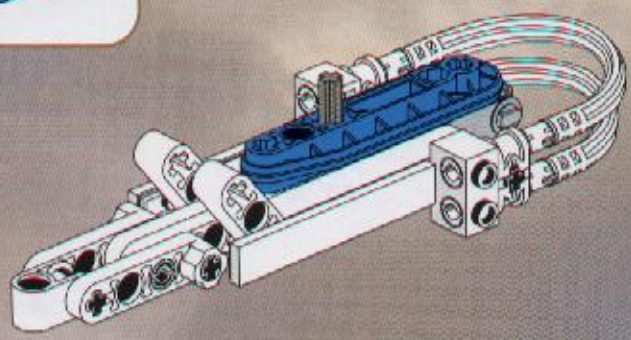
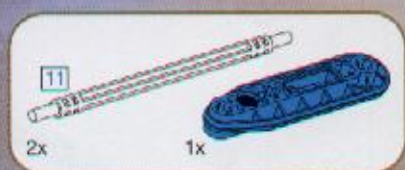

12

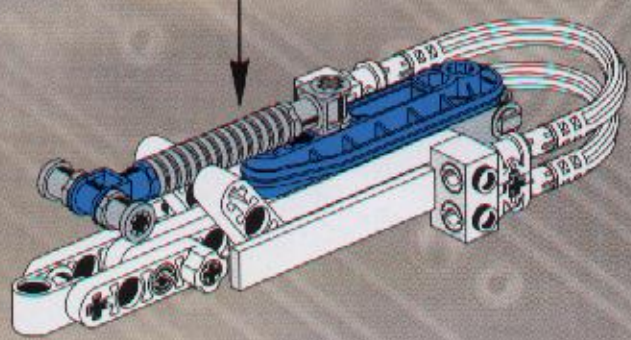
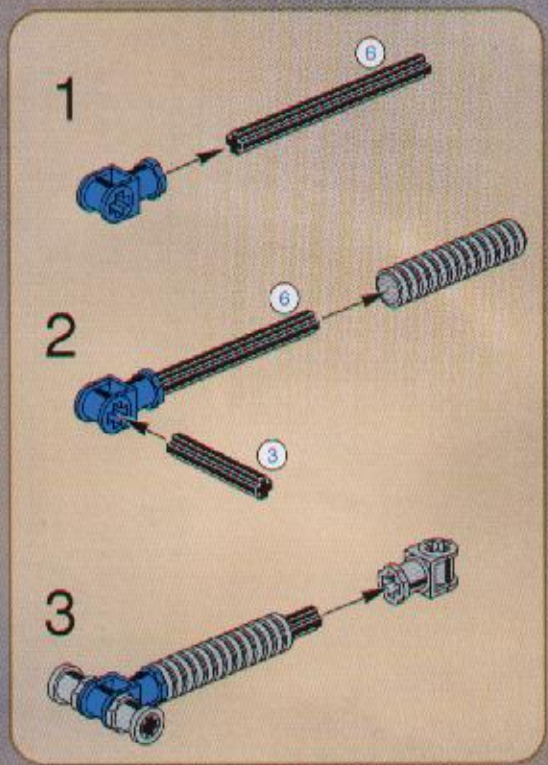
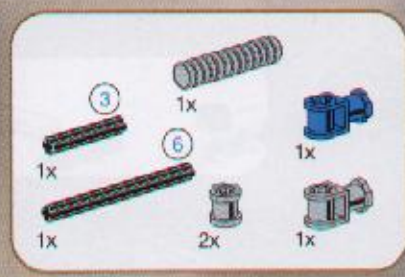

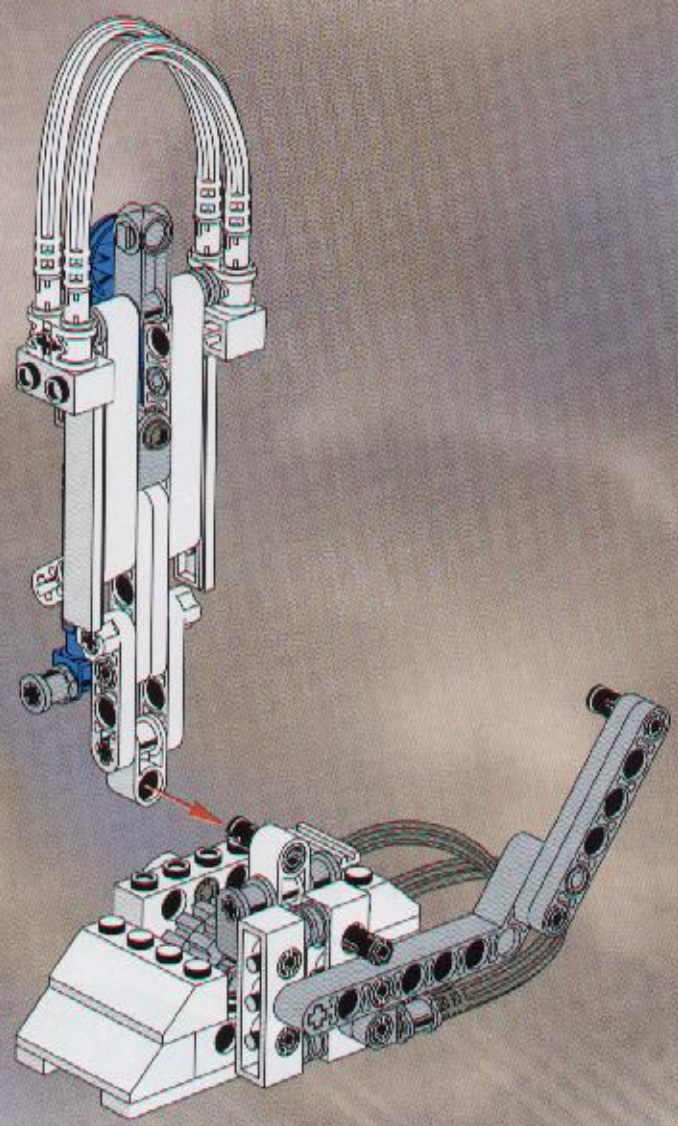

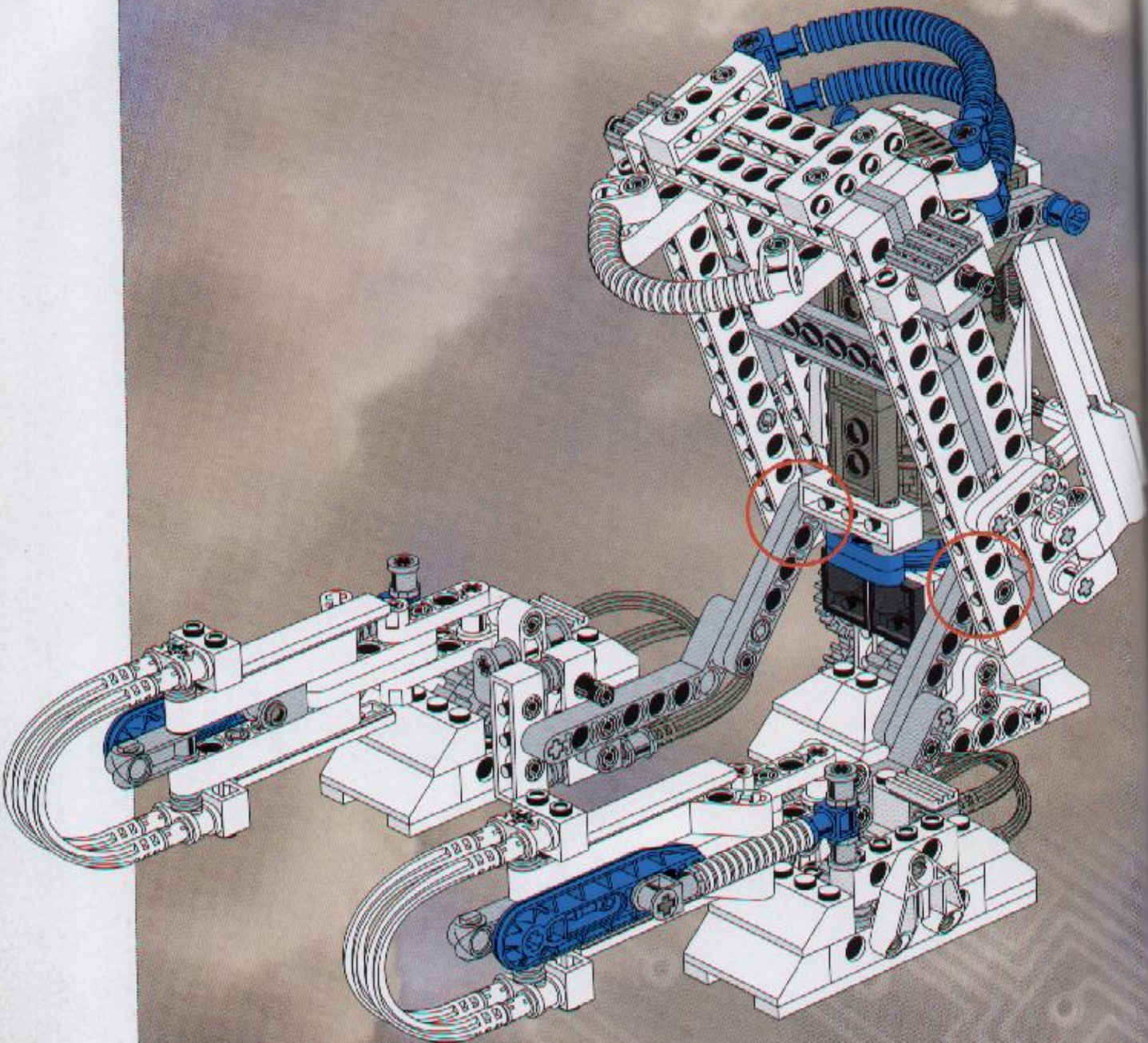

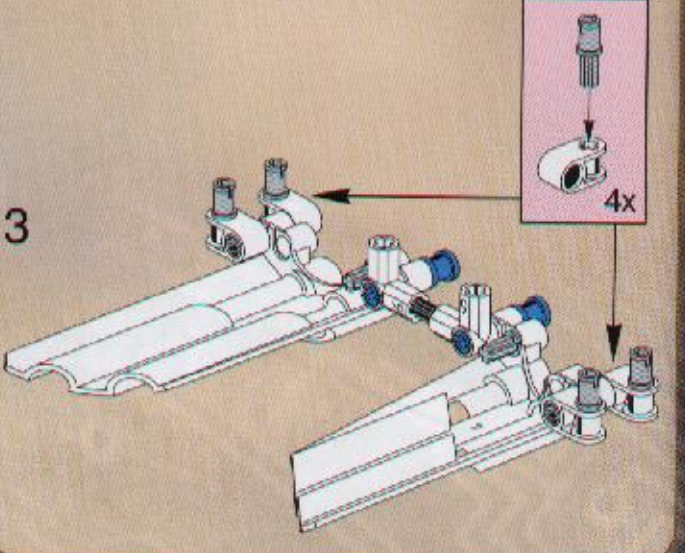
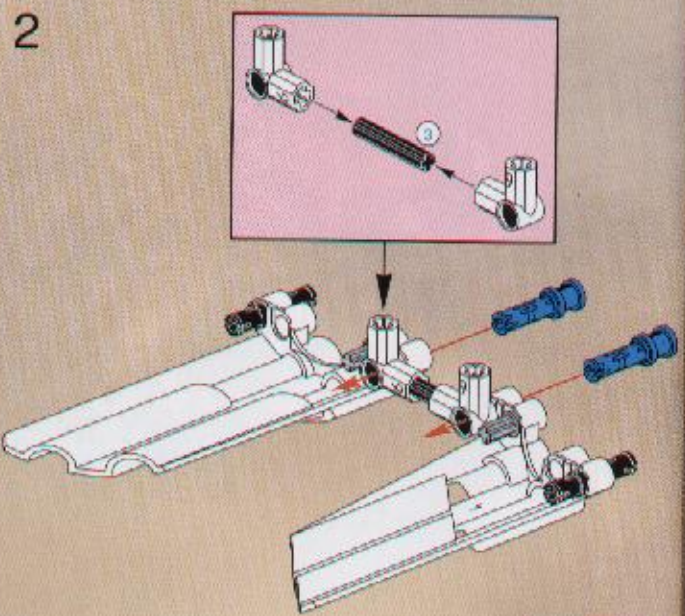
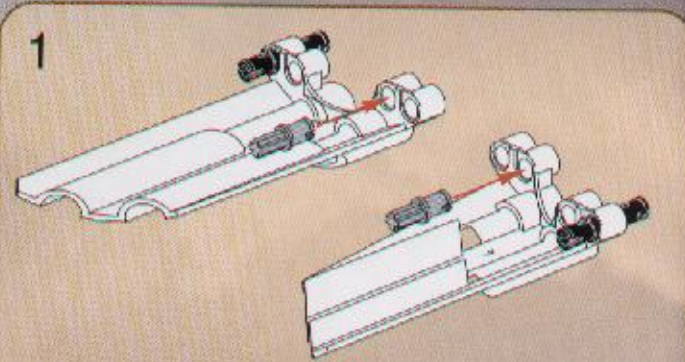
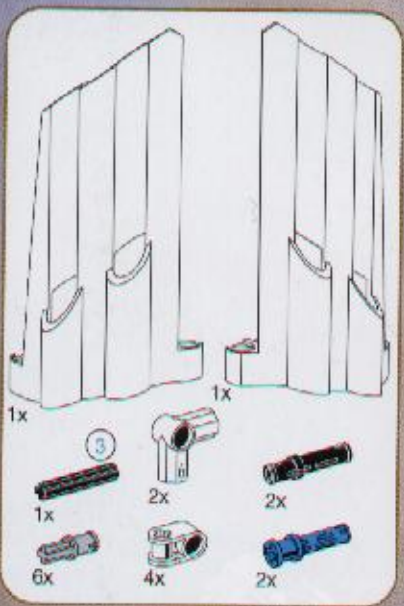



20

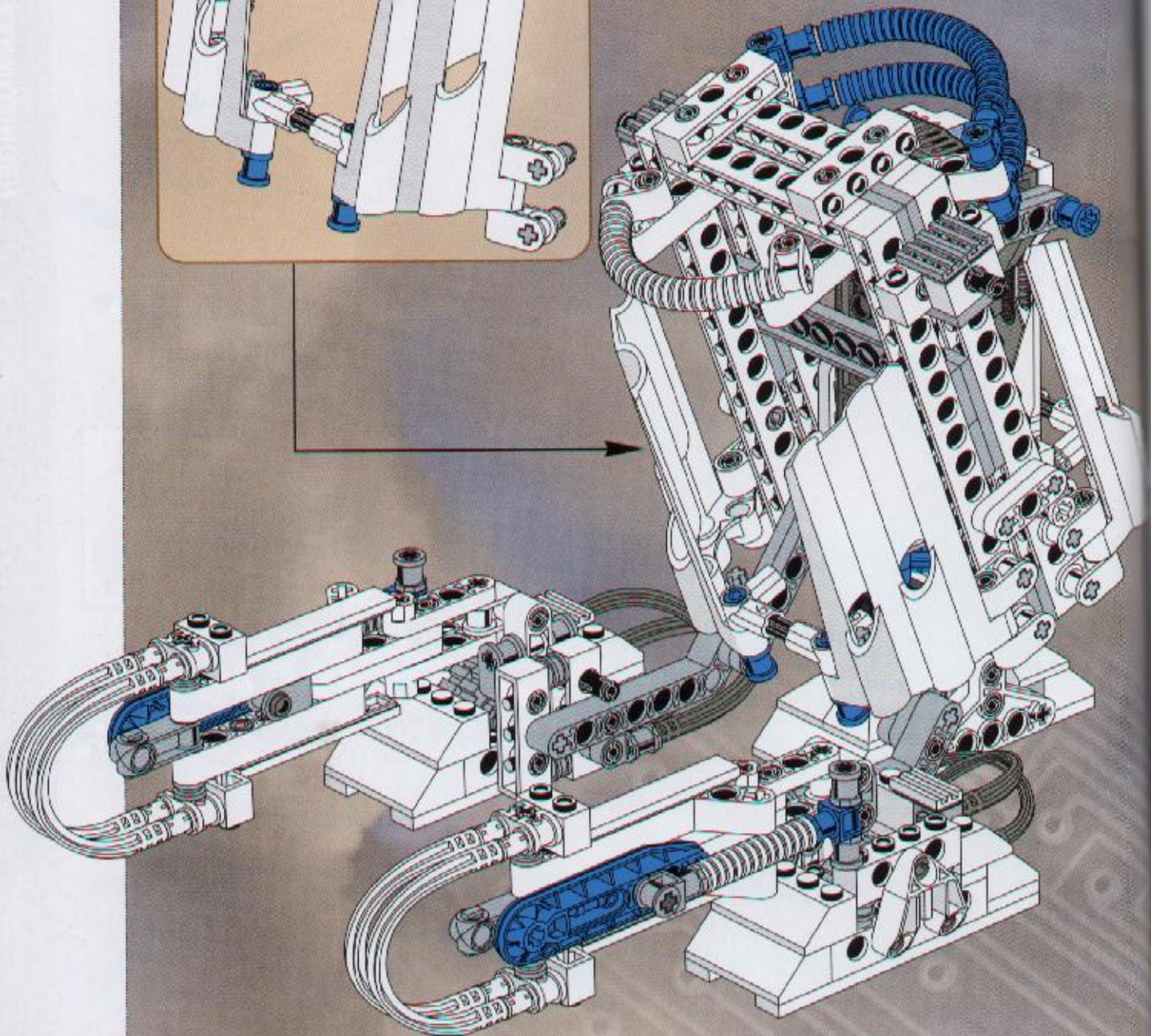
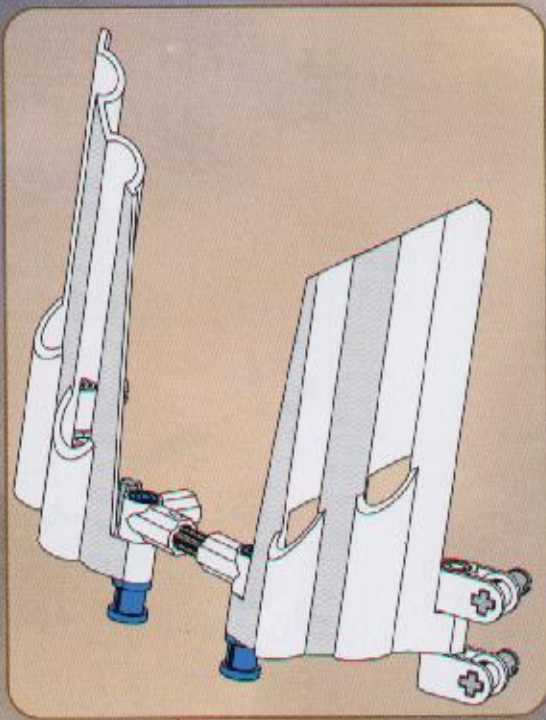

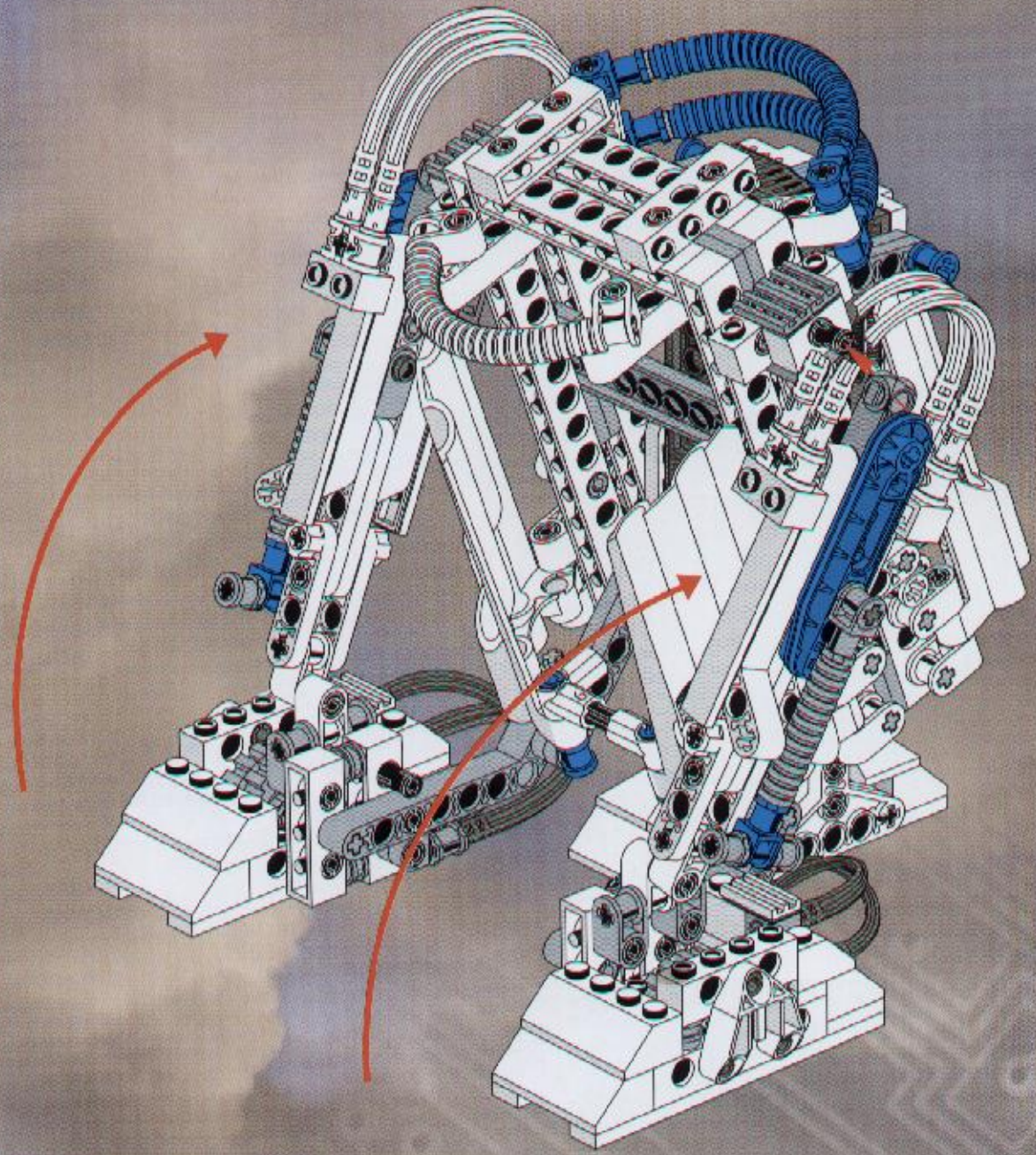



1

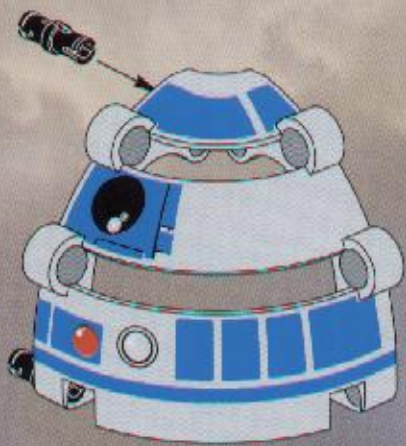
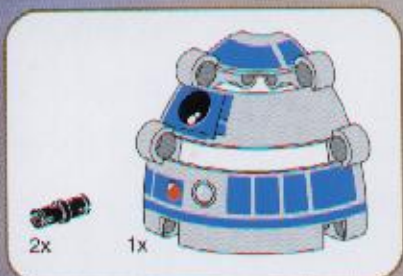

2

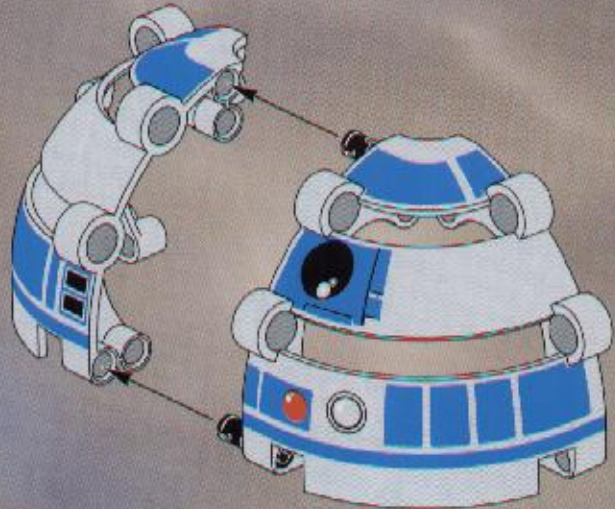
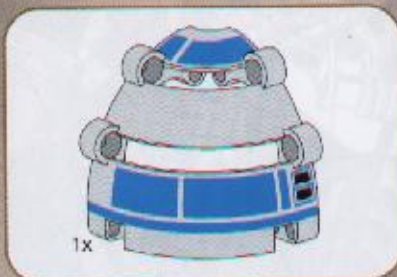

3

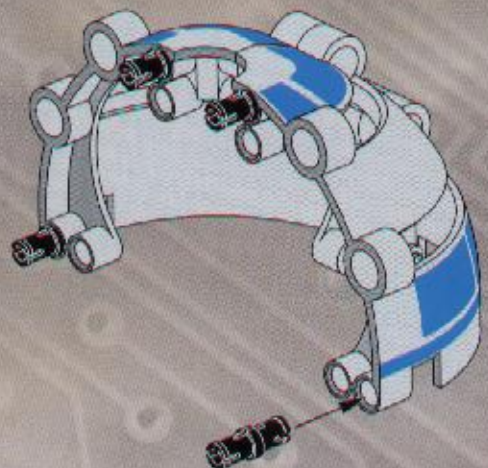

ROBOTECHNIK

4

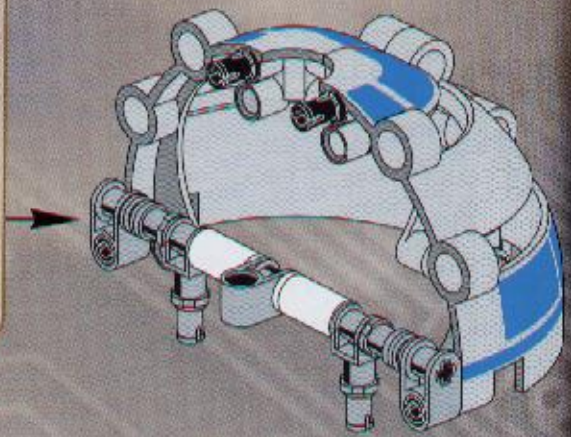
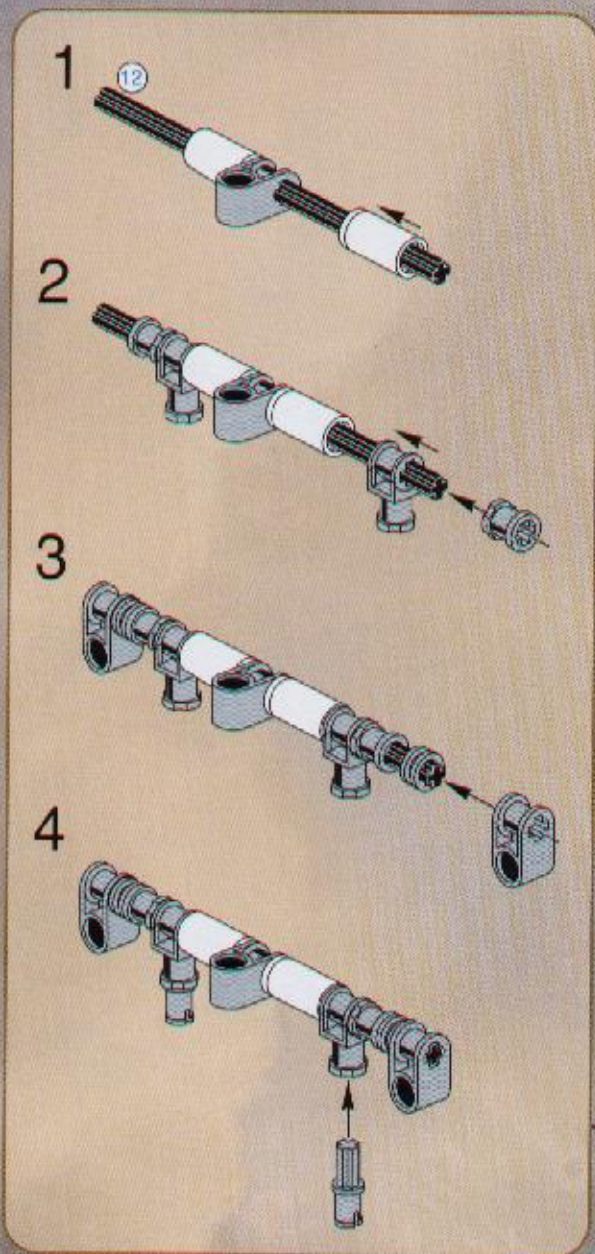
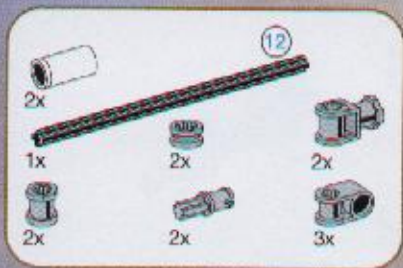



5

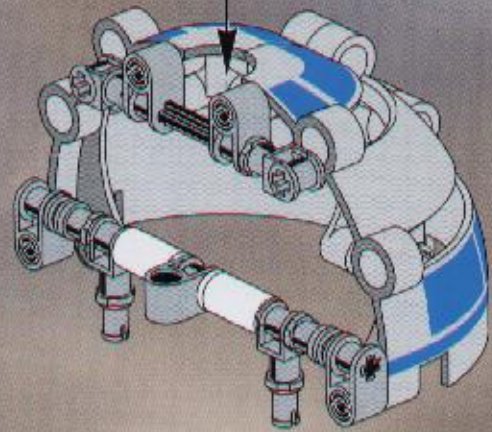
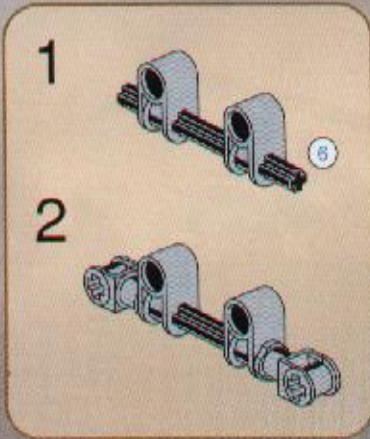
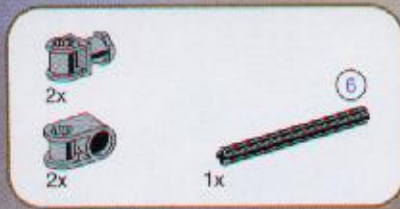

6

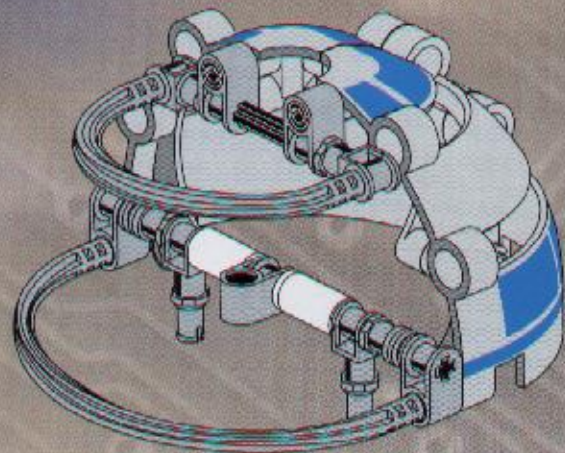
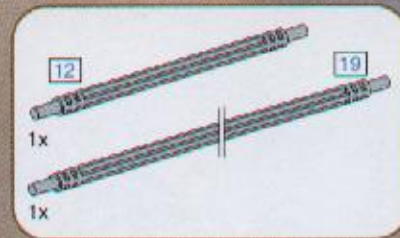

INLEIDING

BEGINNEN

BOUWANWIJZINGEN

SPECIALE TOEPASSINGEN

TECHNISCHE TOESTANDE

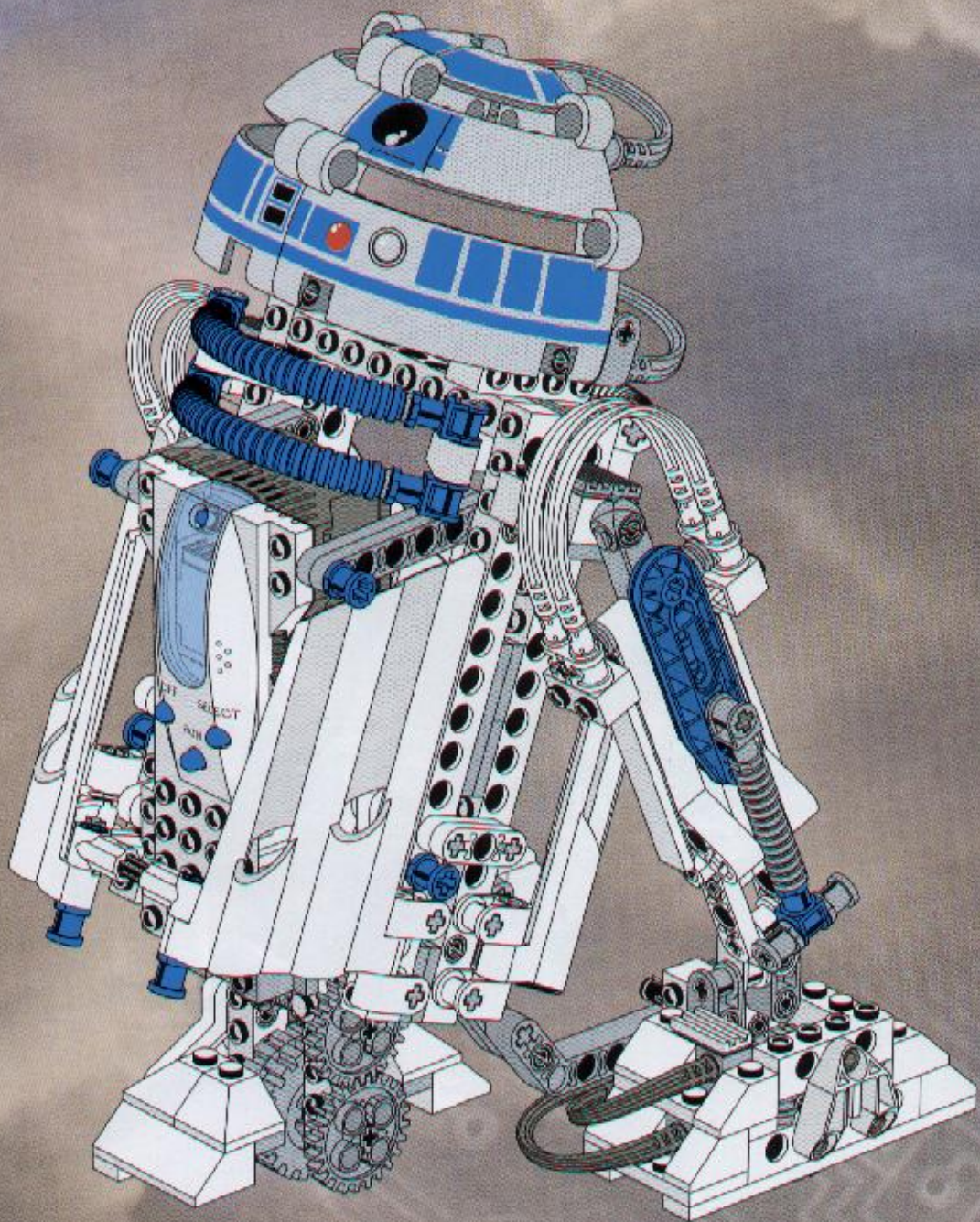

www.lego.com

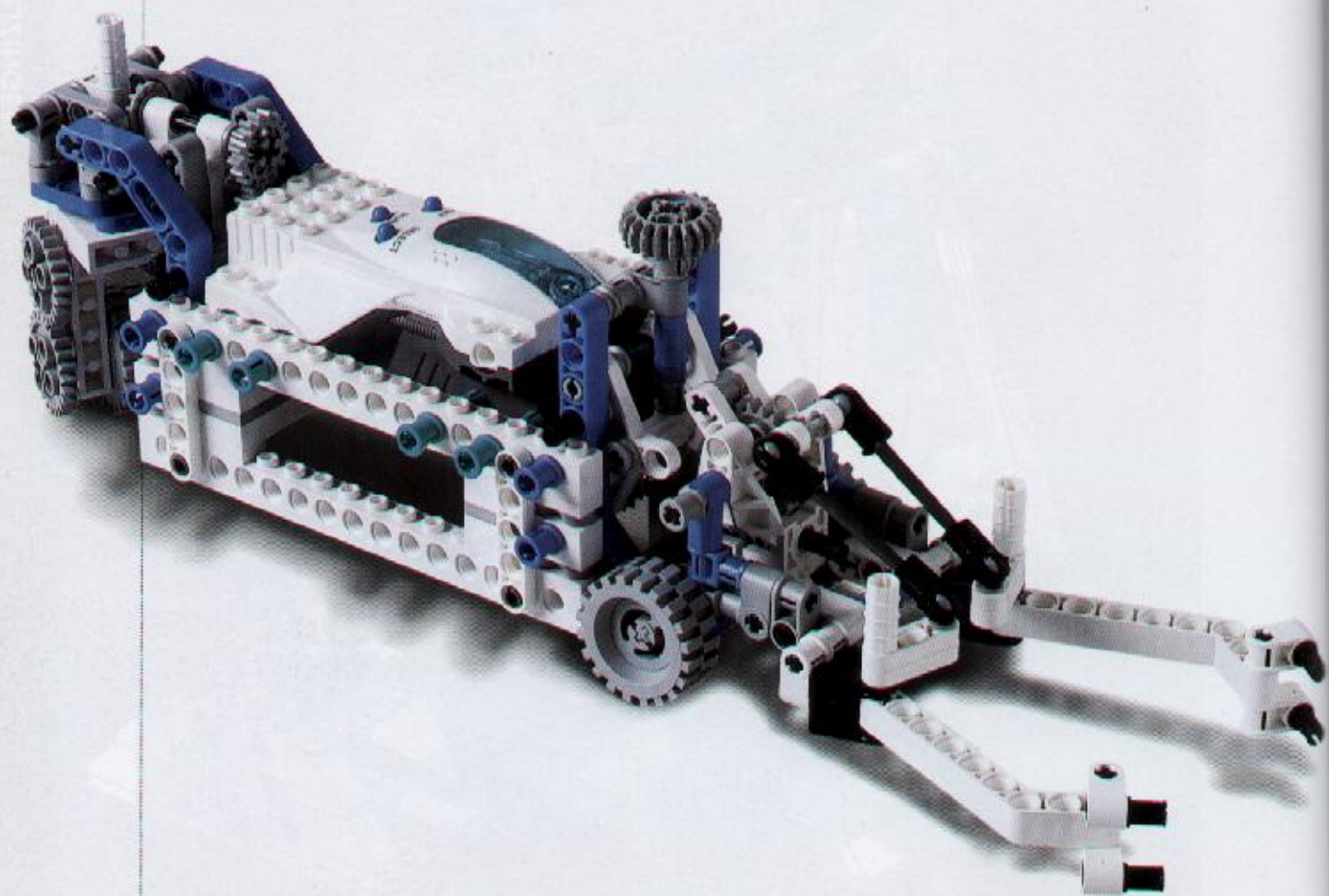

1

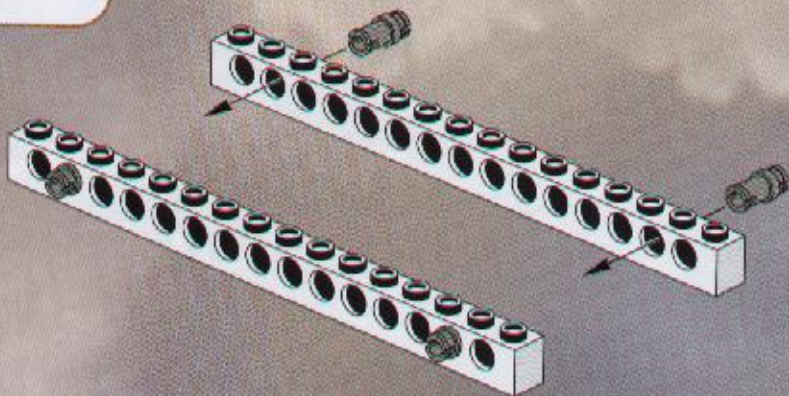
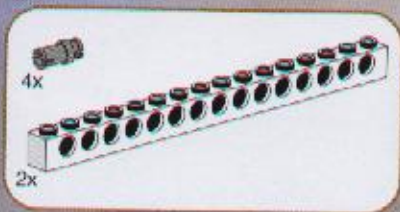

2

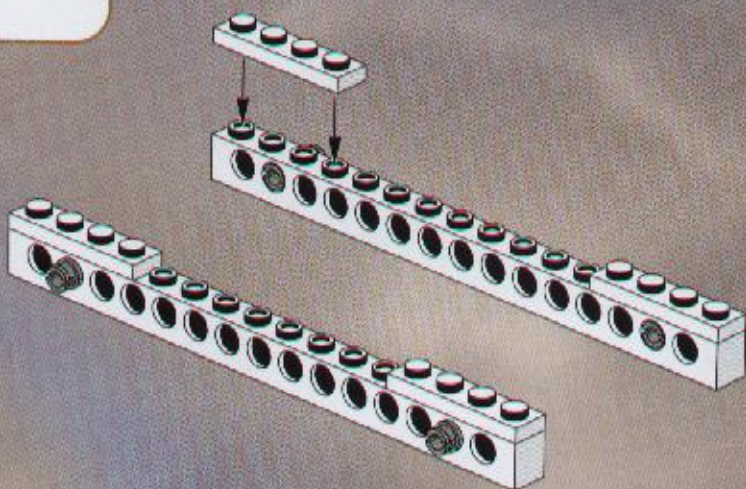

3

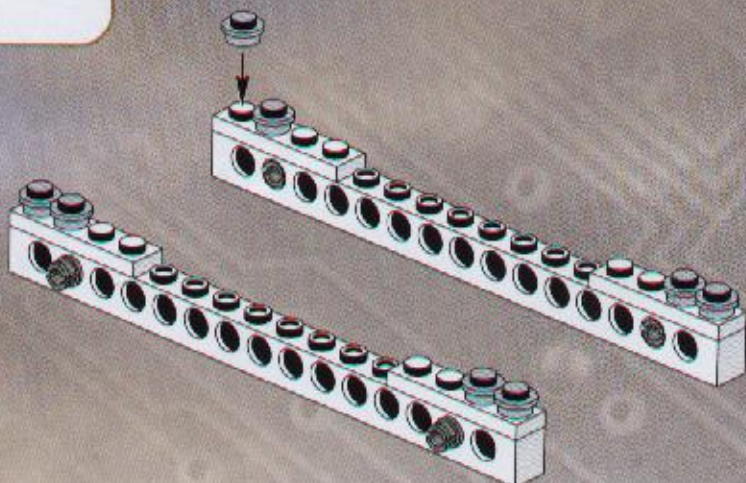

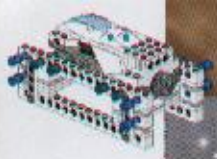

4

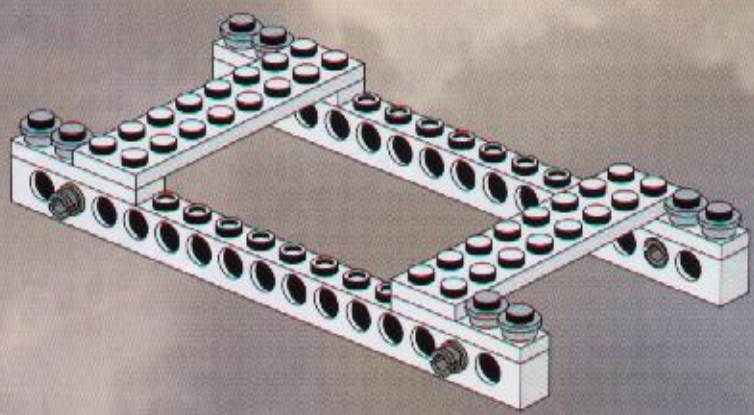

5

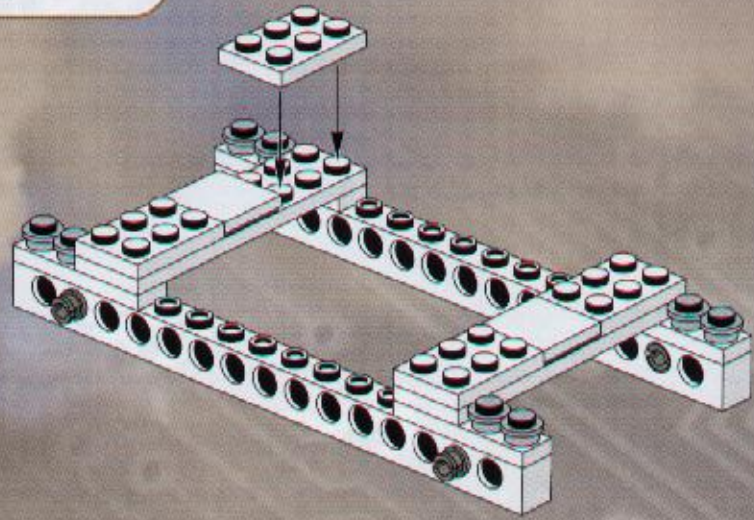

6



4x



4x

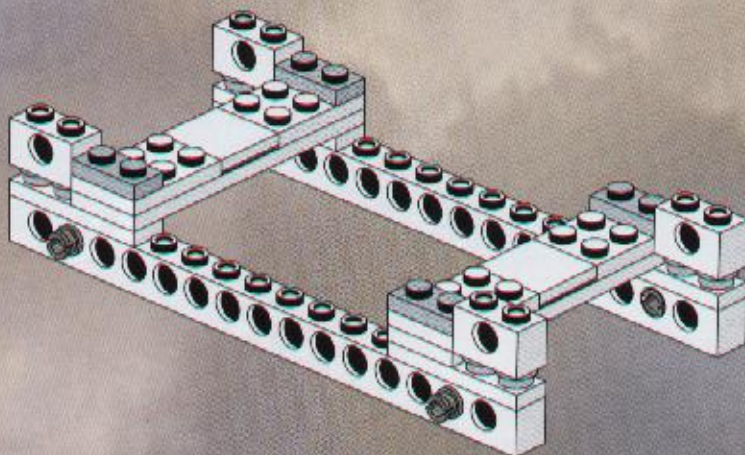

7



4x



4x

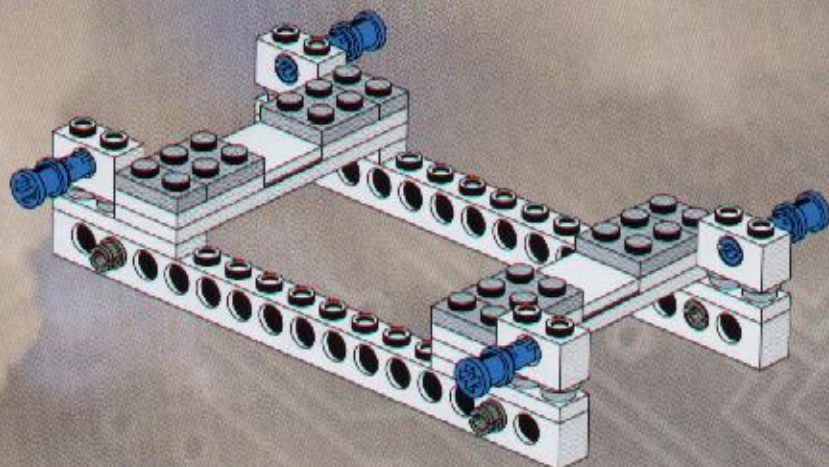



8

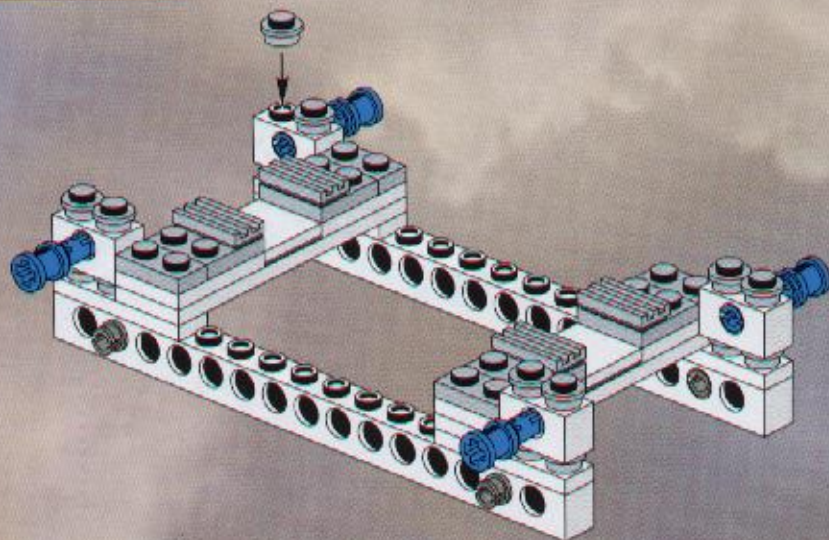

9

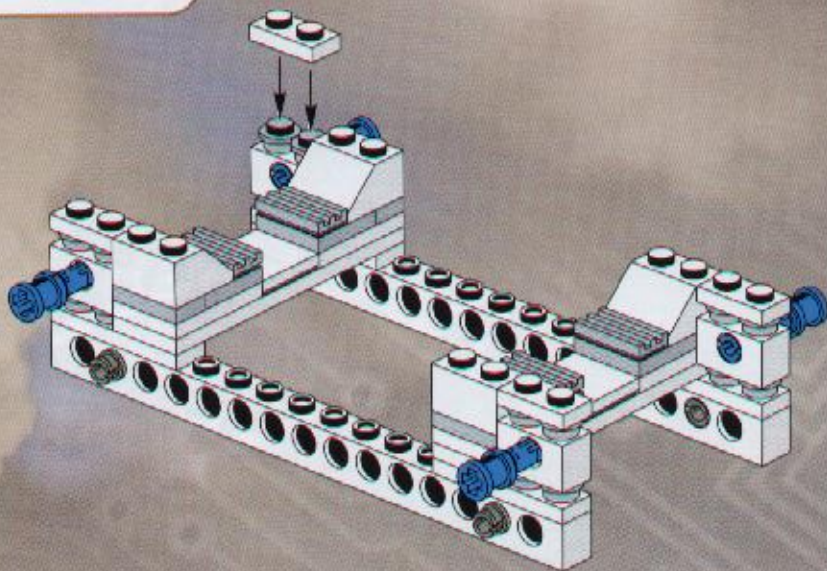

10

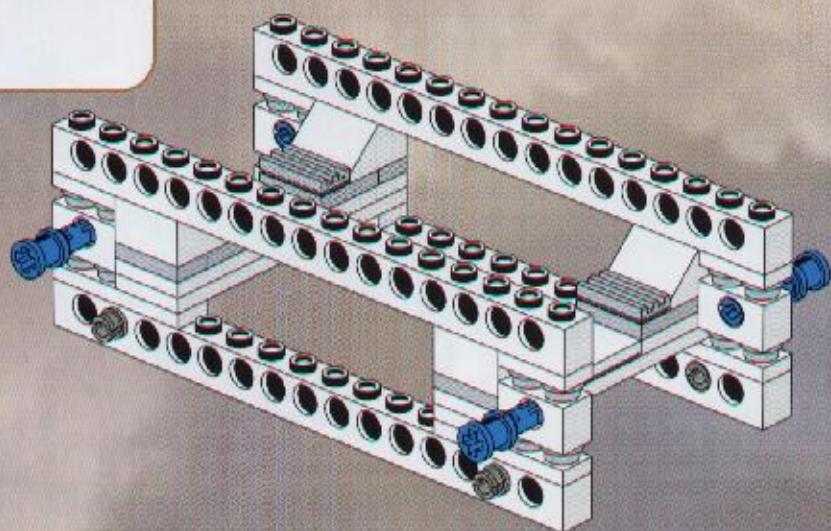
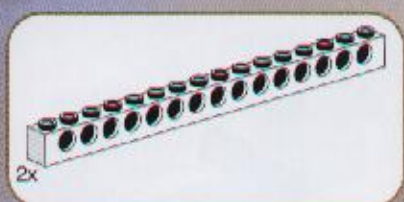

11

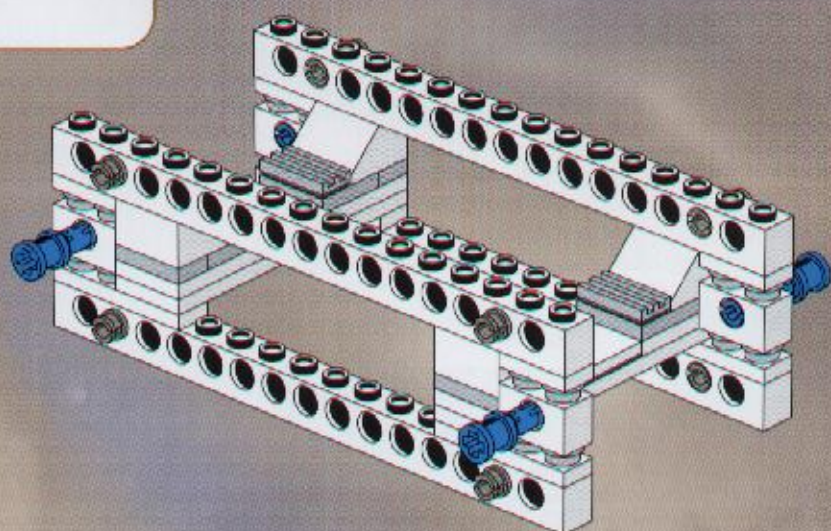

12

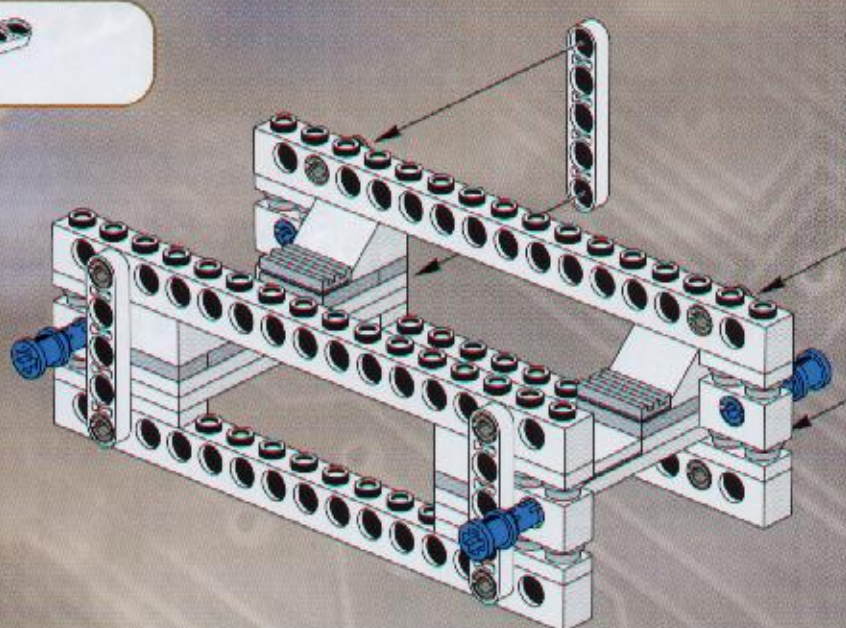

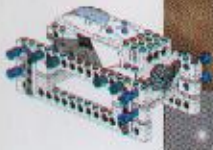

13

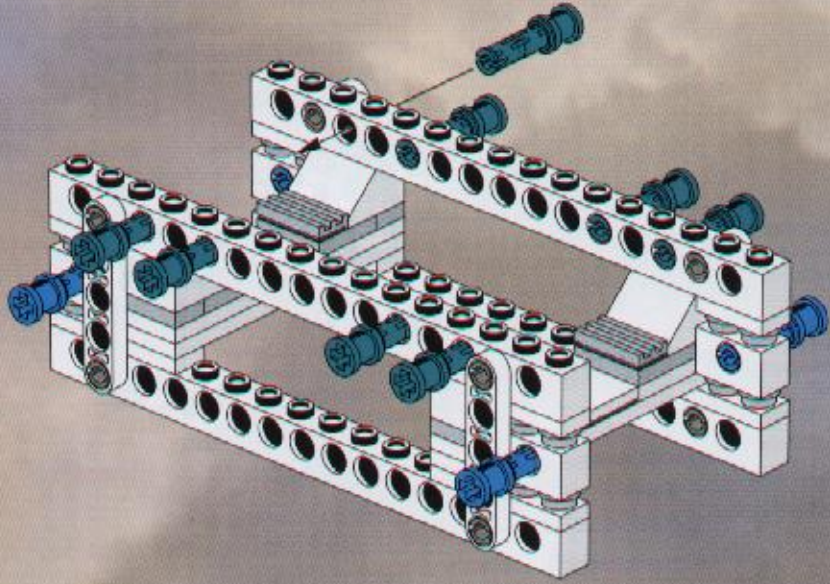

14

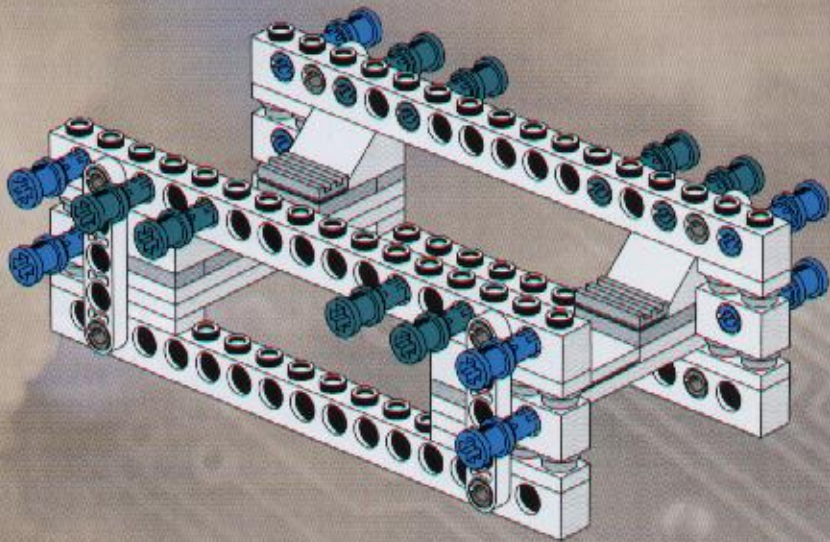

15

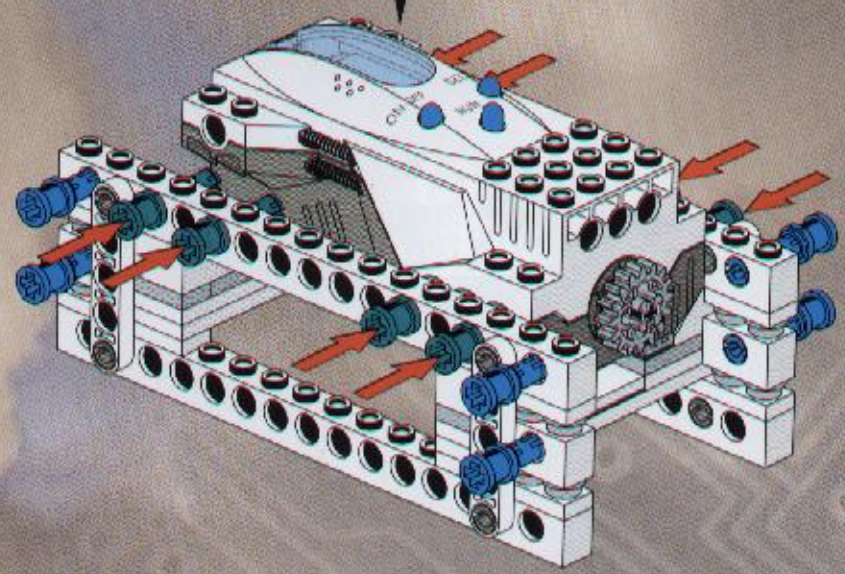
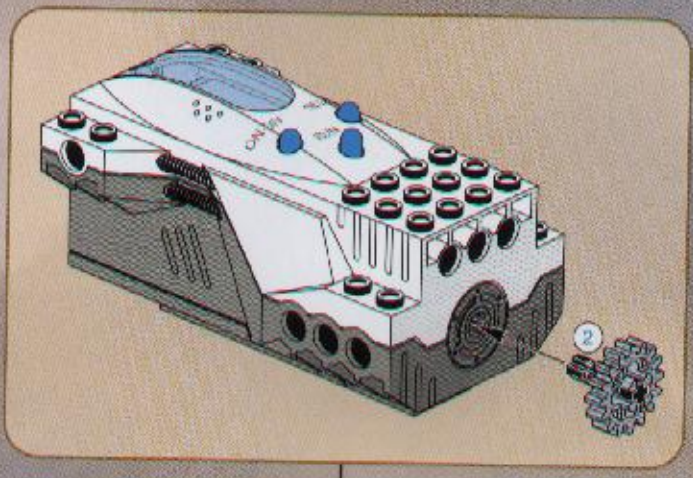
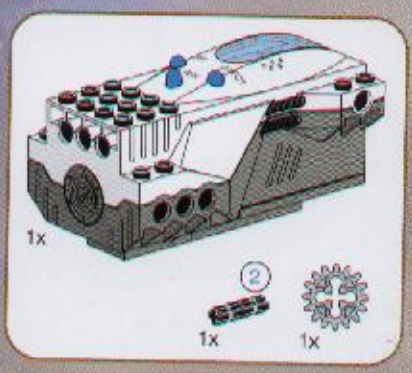

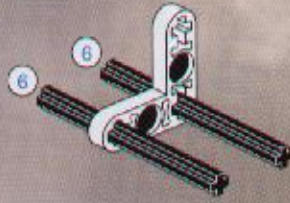
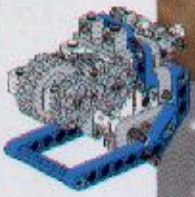



4

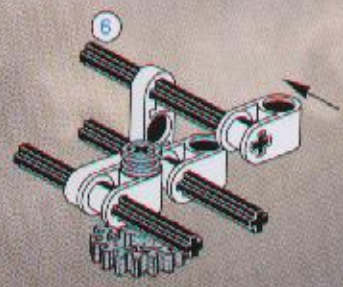

5

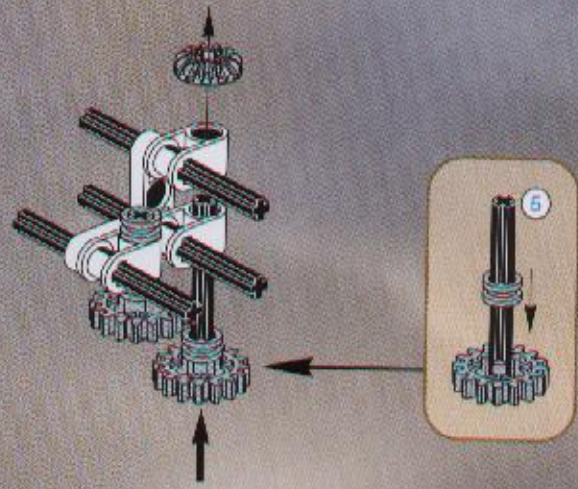
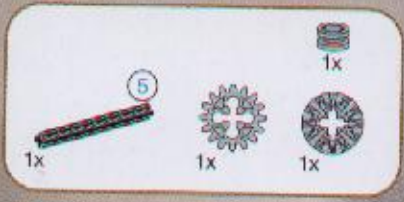

6

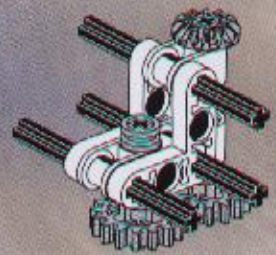

7

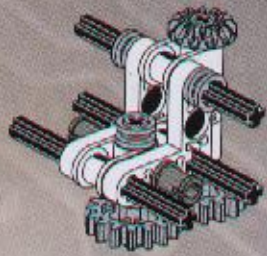

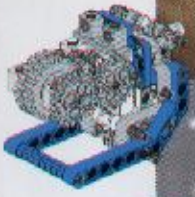

8

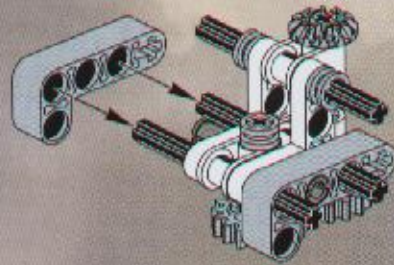
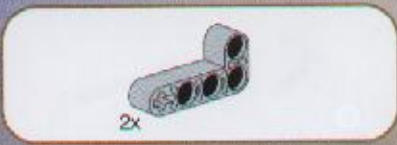

9

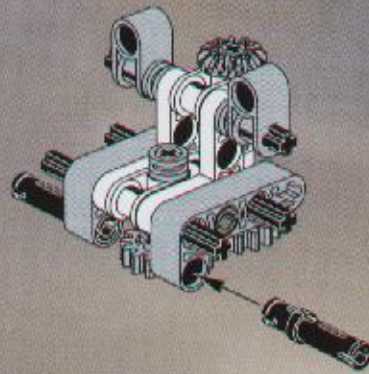

10

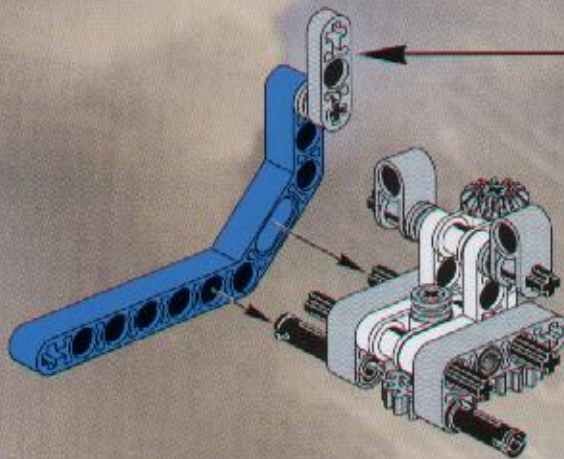
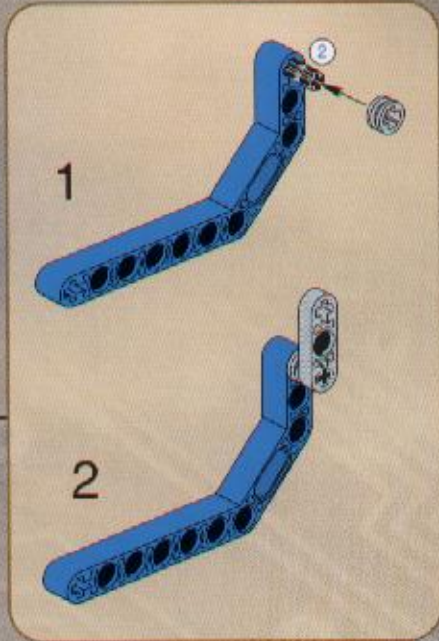
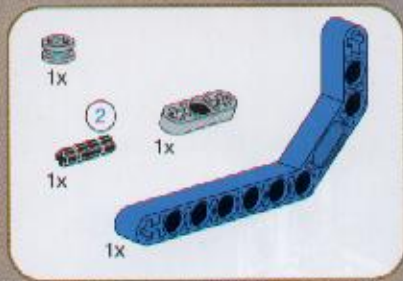

11

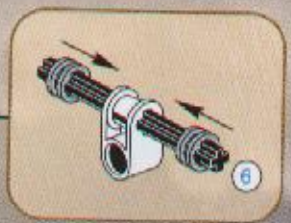
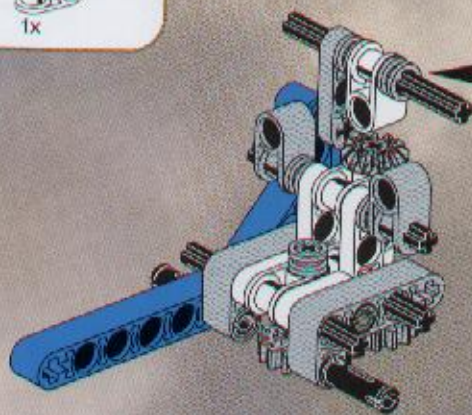
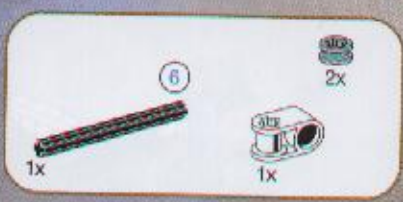

12

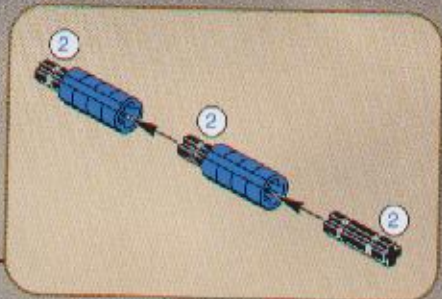
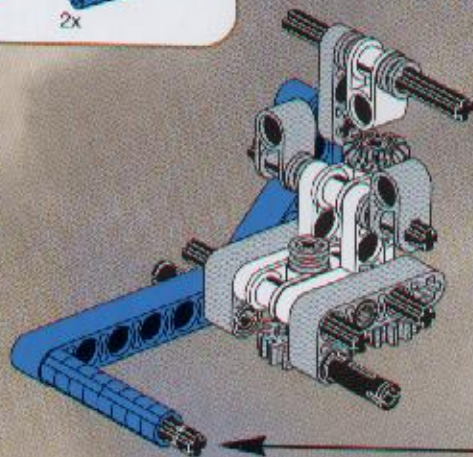

13

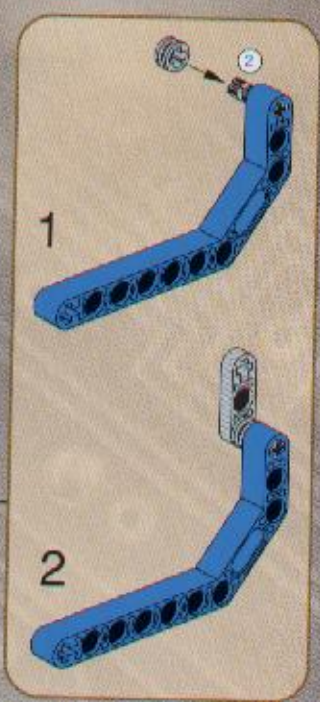
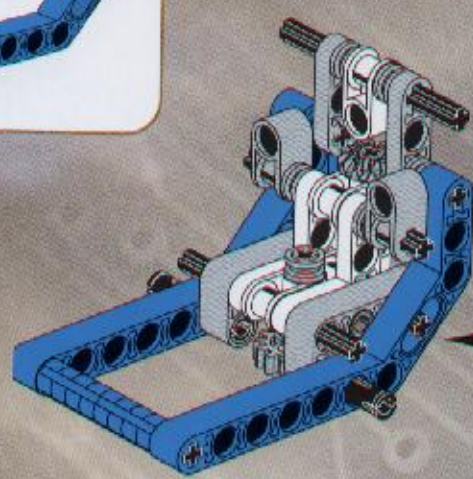
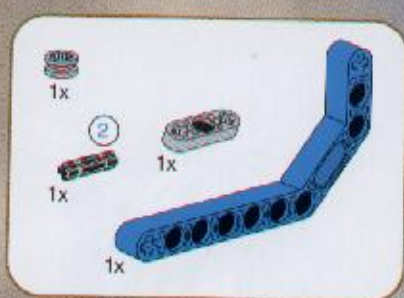



14

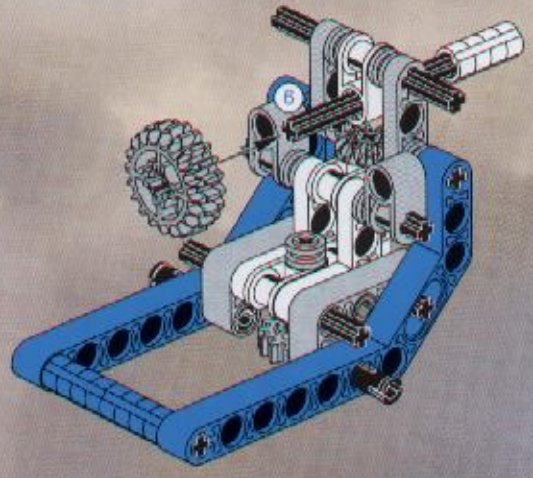
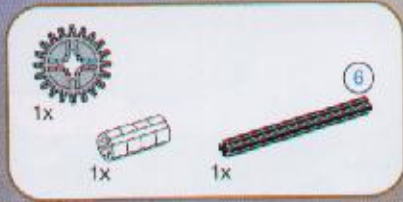

15

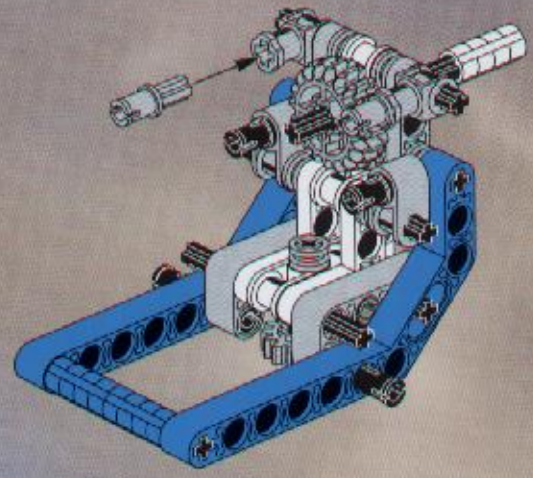

16

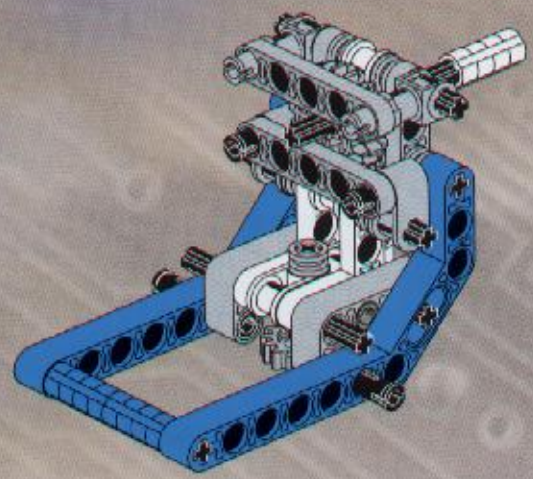

LEGO MINDSTORMS

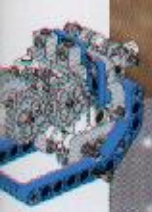

17

- 1x 
- 1x 
- 1x  ②

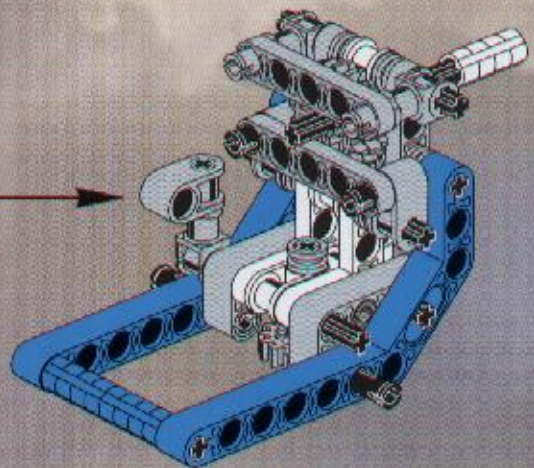

18

- 1x 

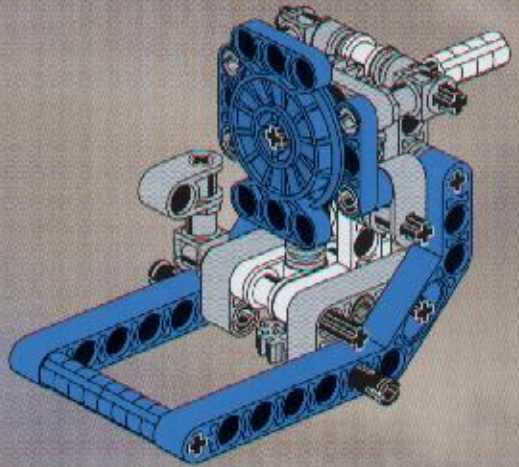

19

- 4x 

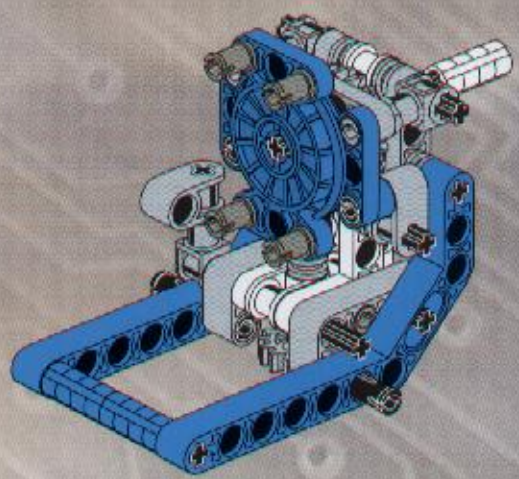



1

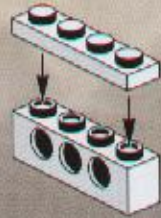

2

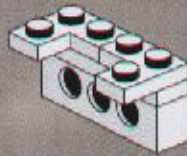

3

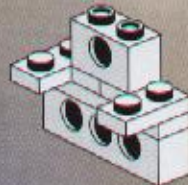

4

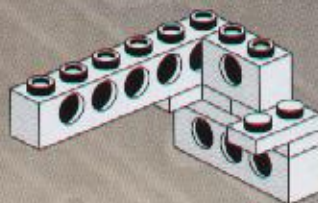
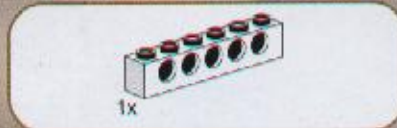

LEGO Technic 11331



5

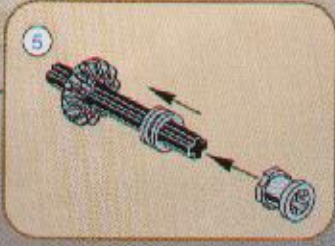
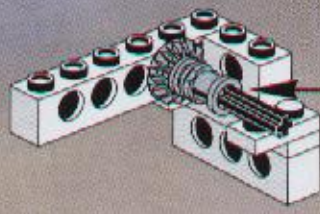

6

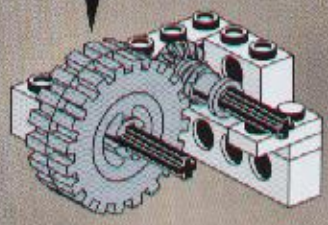
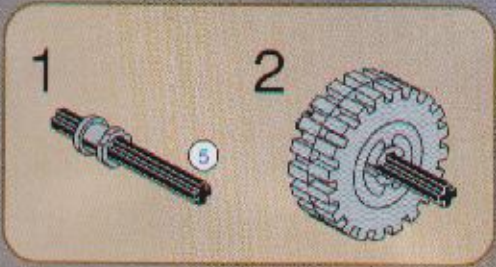
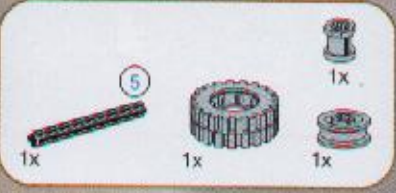

7

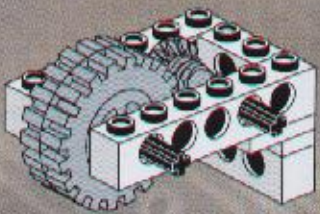
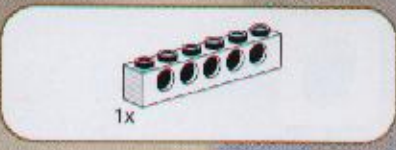

8

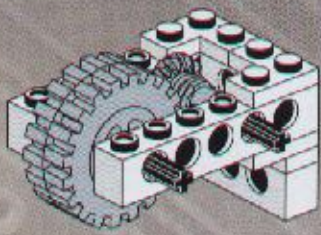

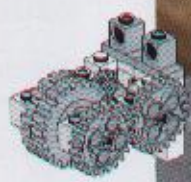

9

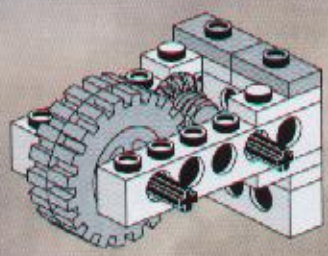

10

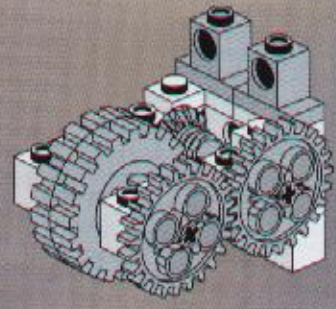
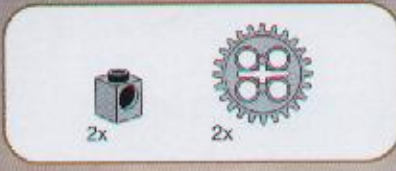

20

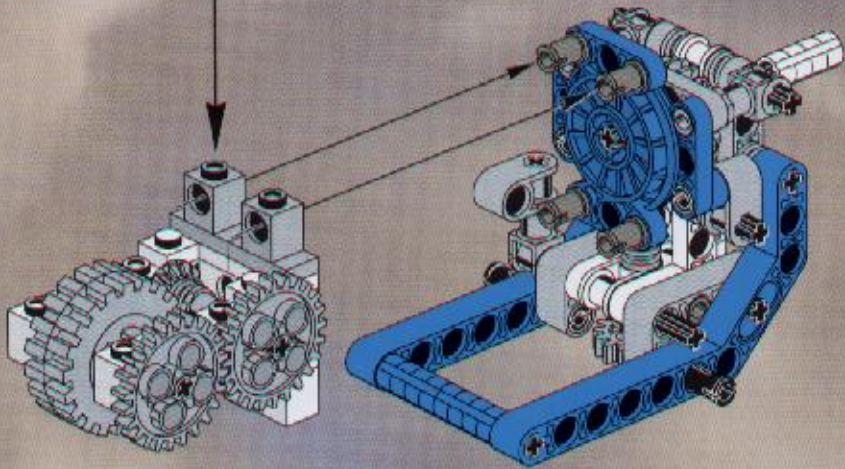

21

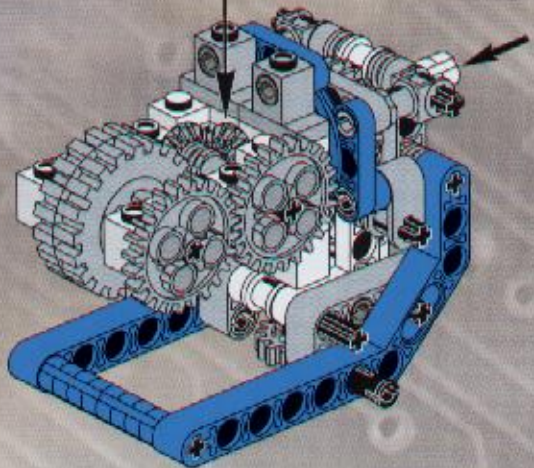

LEGO CLYDE WILSON



1

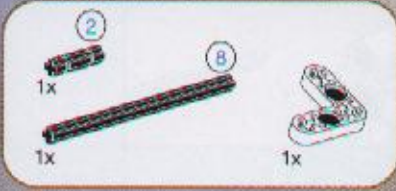

2

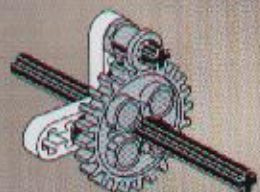
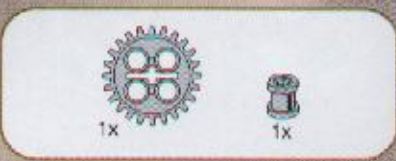

3

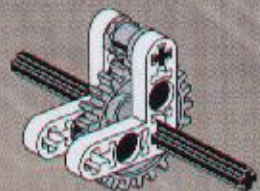



4

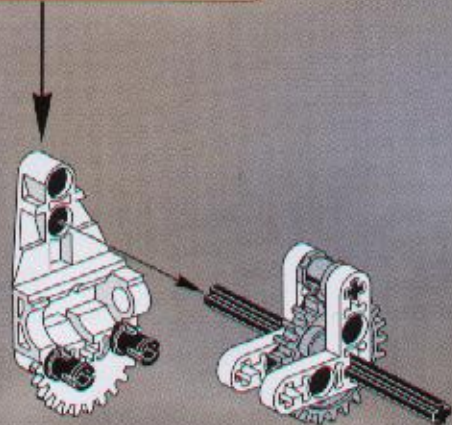
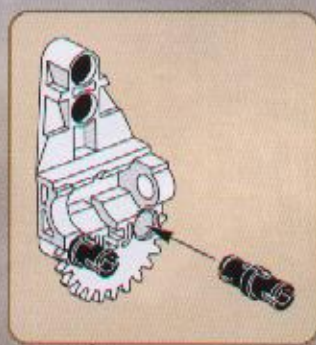
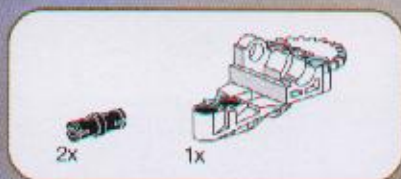

5

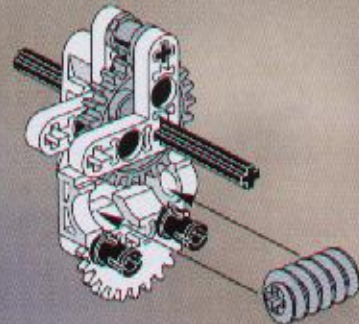
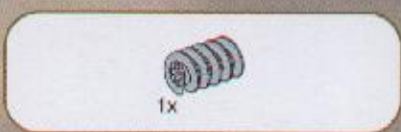

6

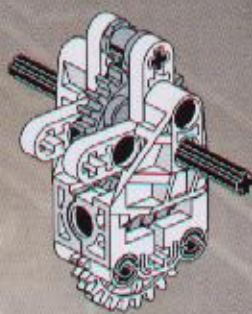
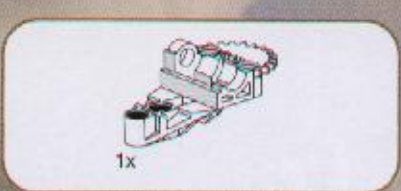

7

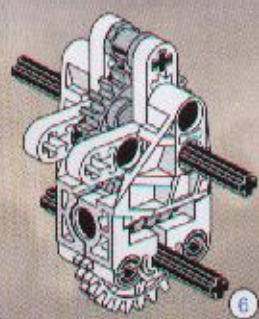

8

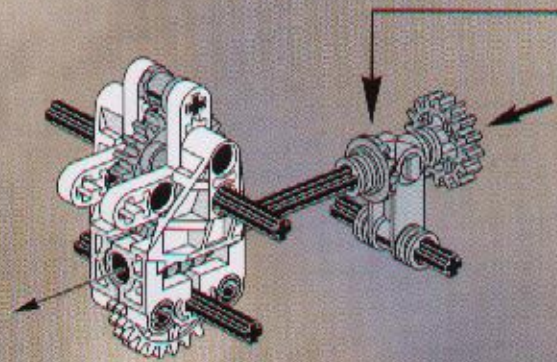
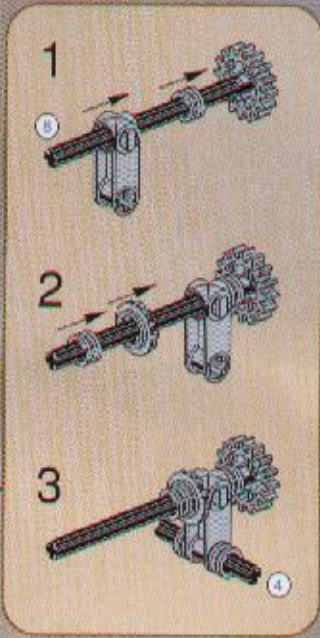
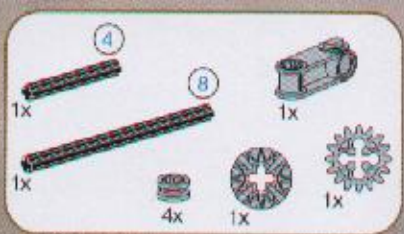

9

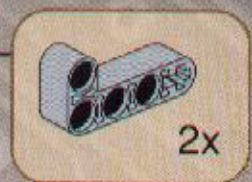
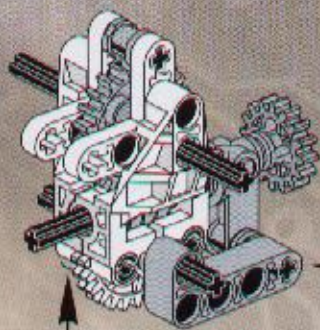



10

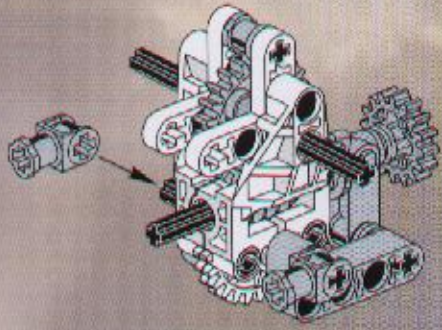

11

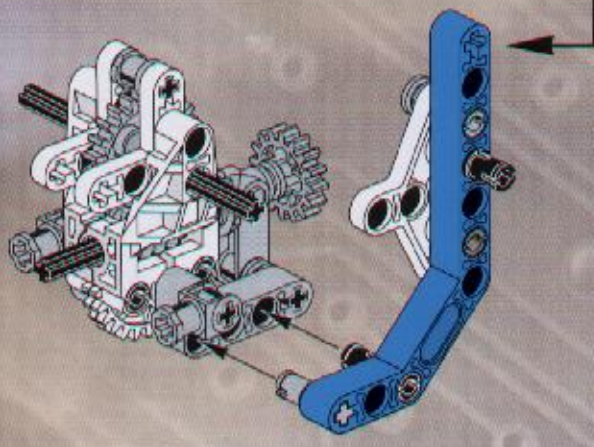
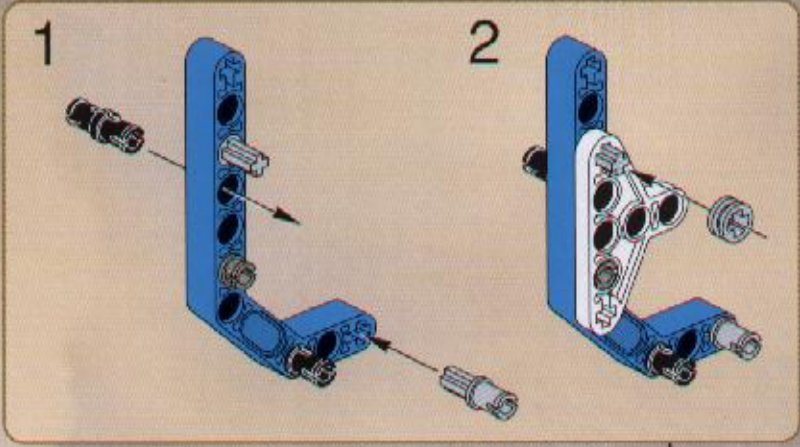
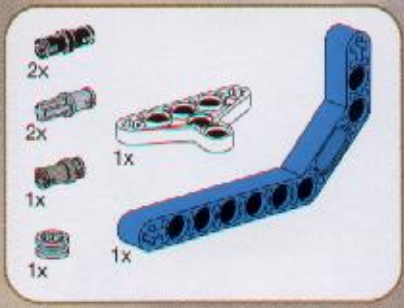

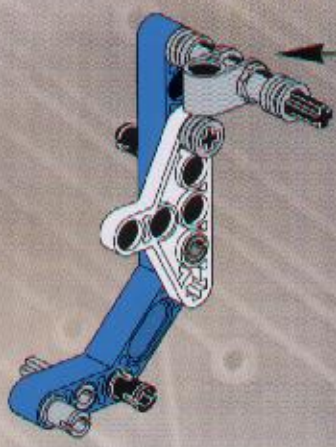
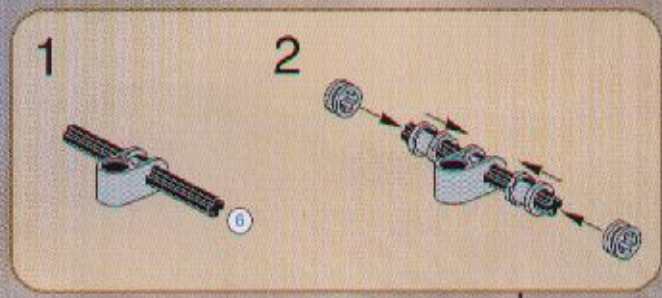
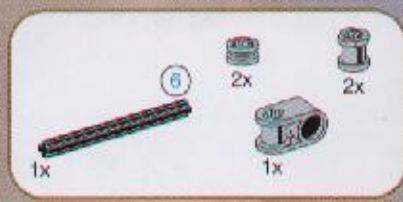
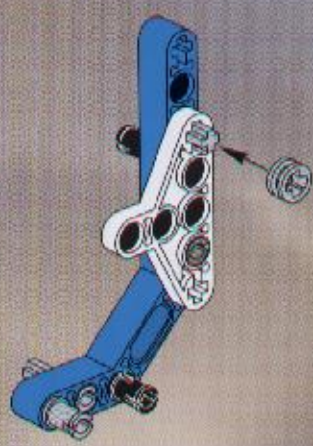
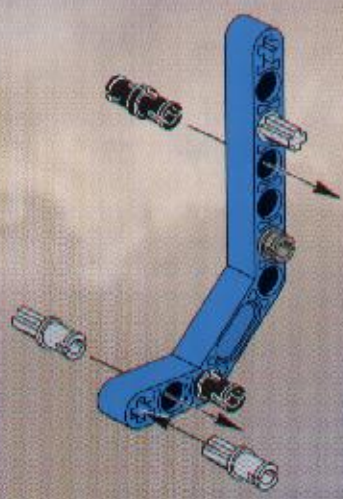
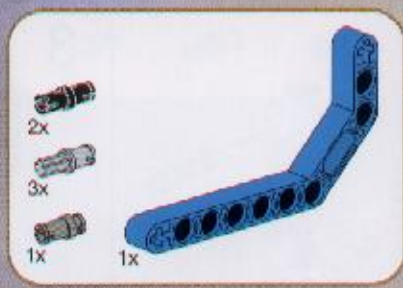



4

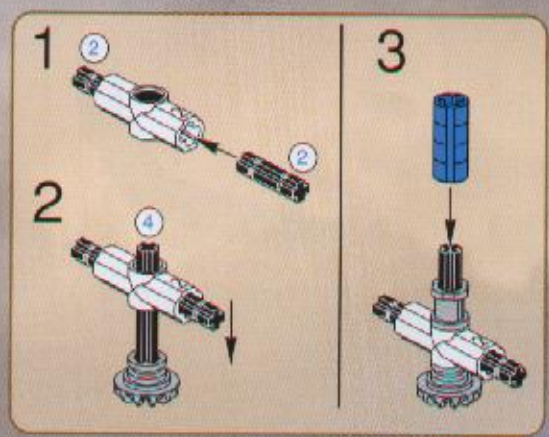
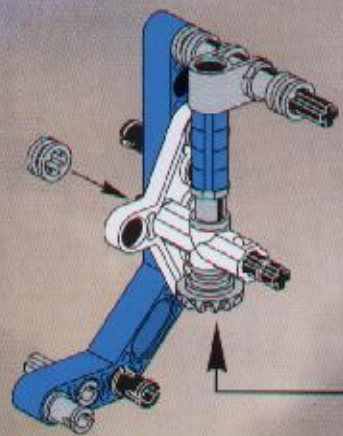
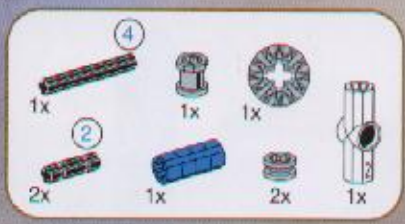

BOHNERKIMMELN

5

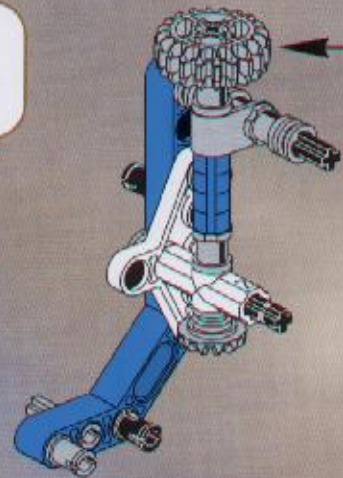

12

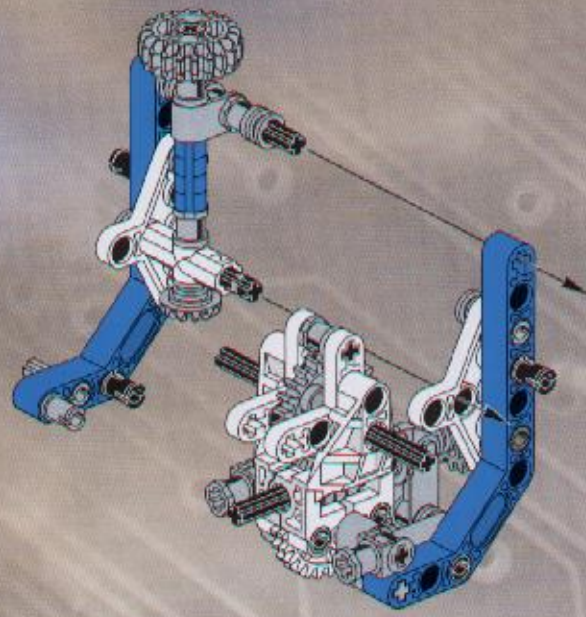



13

- 2x
- 1x
- 1x

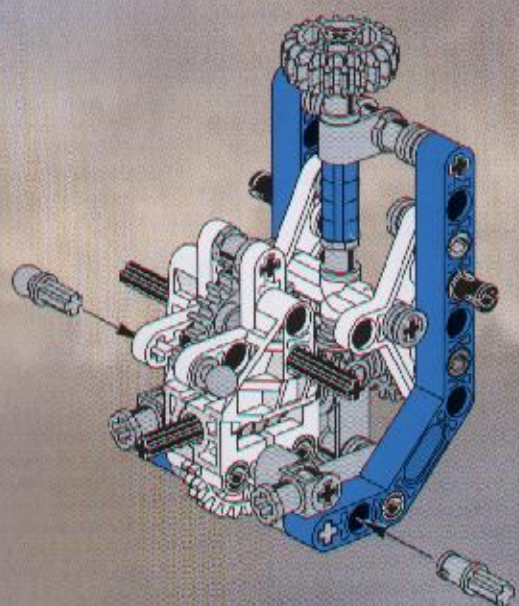

14

- 1x
- 1x
- 1x
- 1x
- 1x

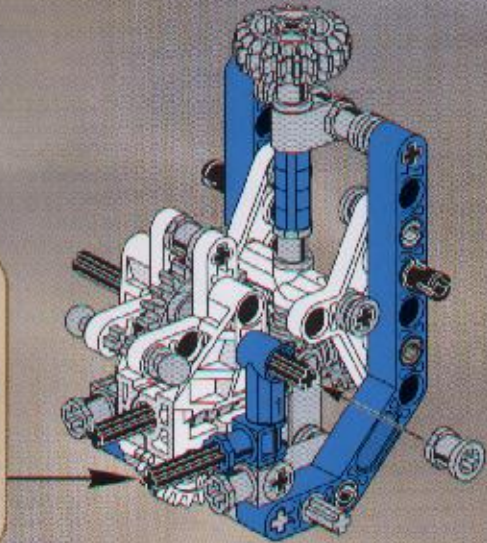
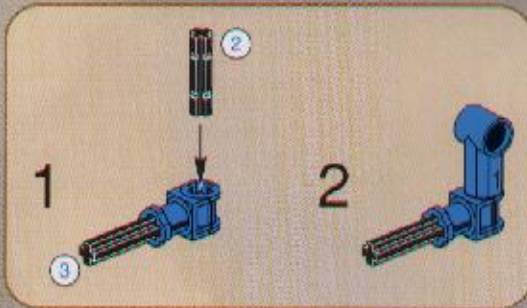

15

- 1x
- 1x
- 1x
- 1x
- 1x

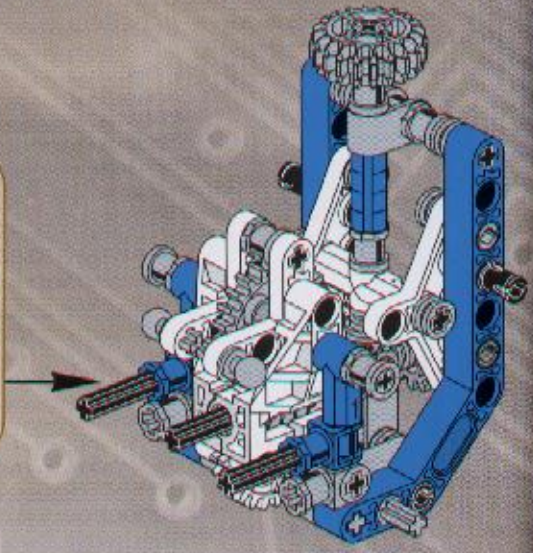
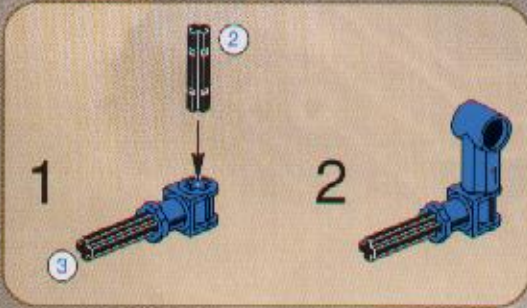



16

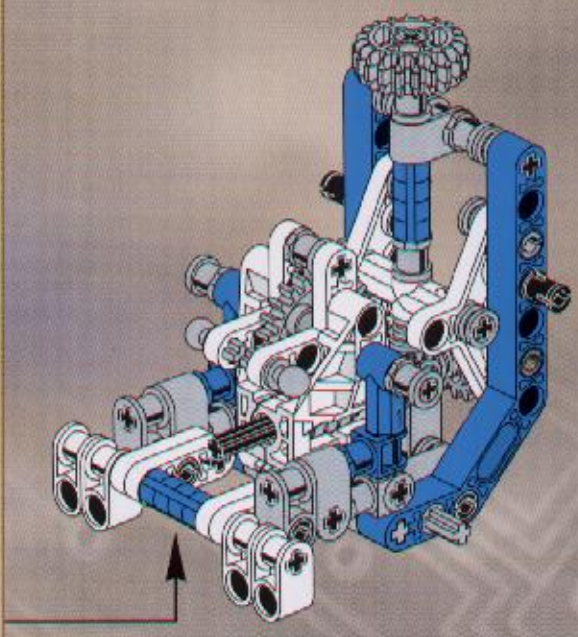
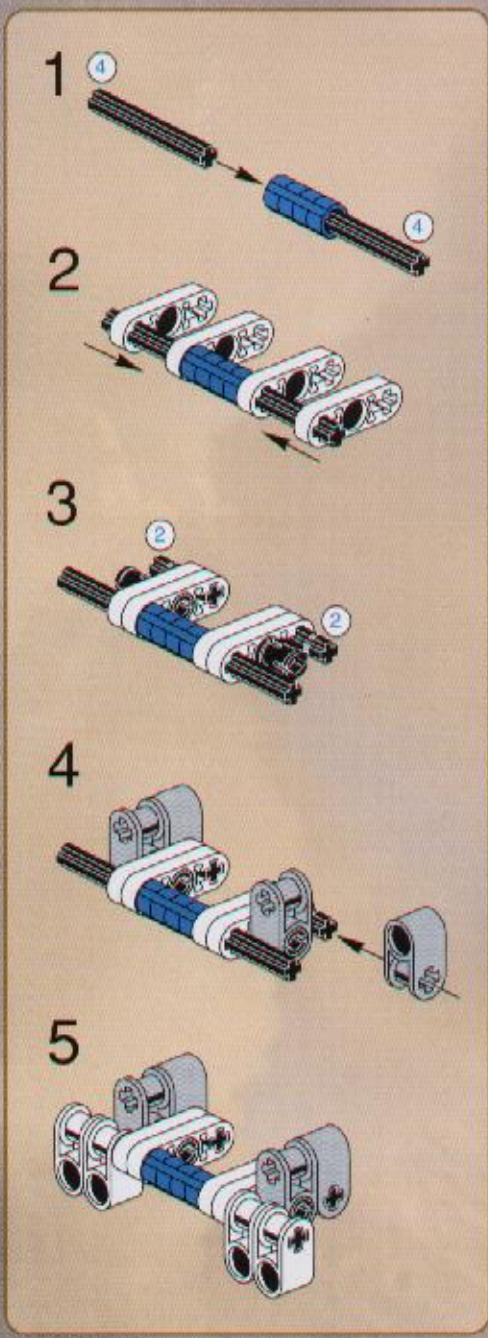
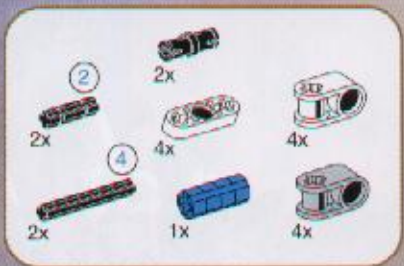

LEGO.com/uk/step-by-step



17

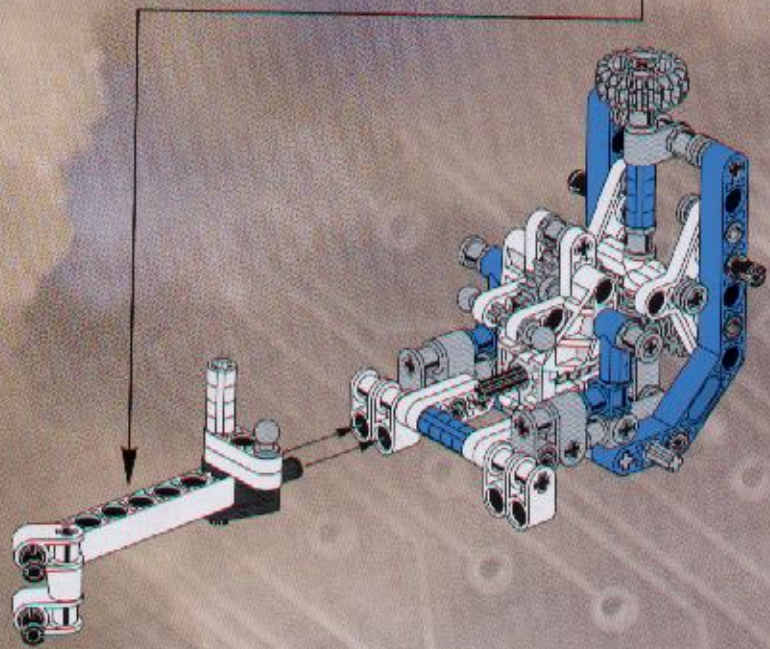
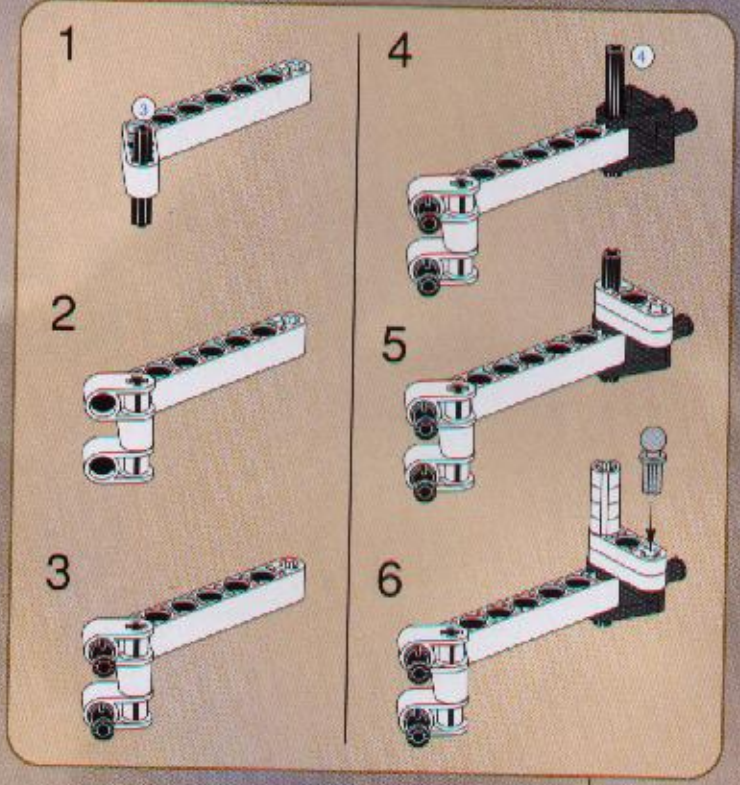
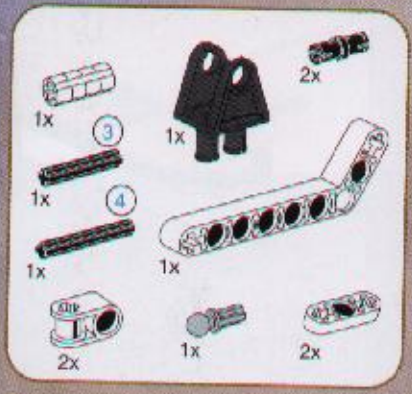

INLEIDING

BASIS

BOUWANWIJZINGEN

SPECIALE TOEPASSINGEN

TECHNISCH TOEGESTANDEN



18

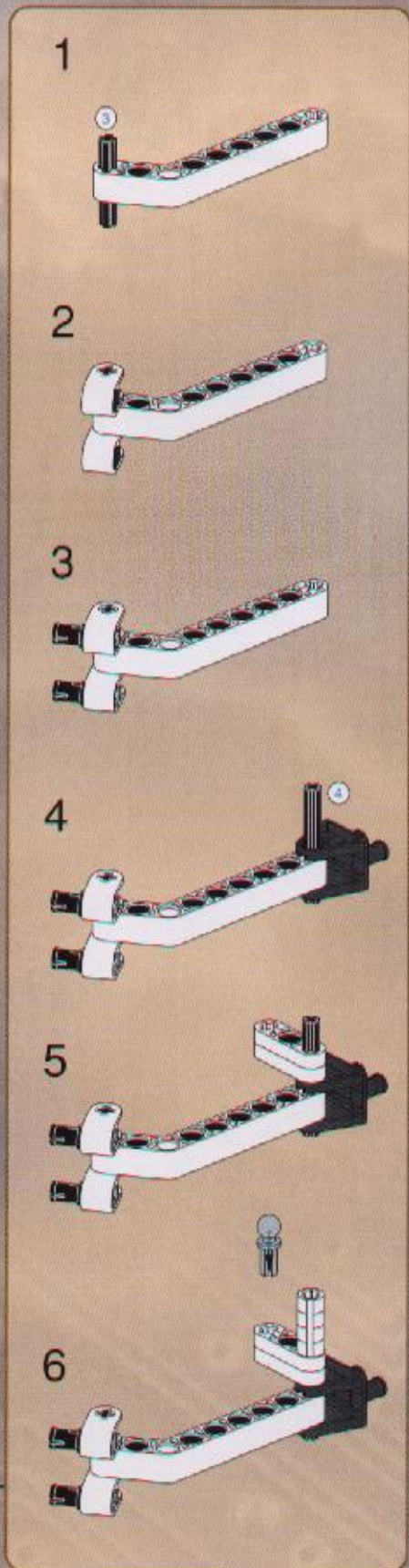
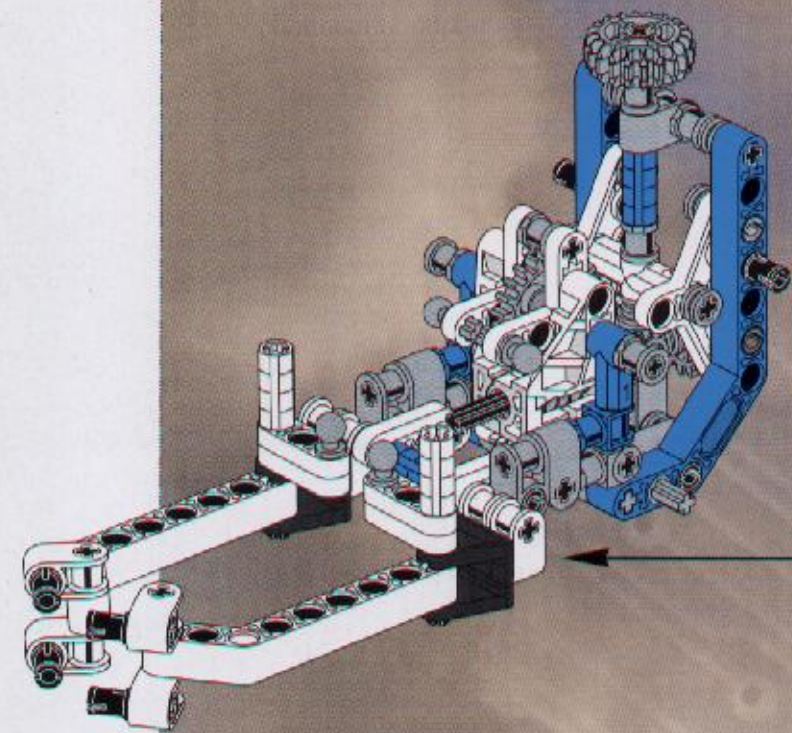
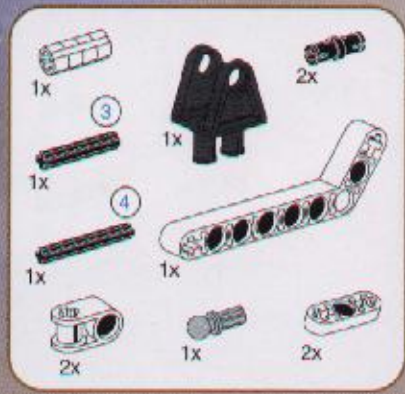

BECHTEL/VAW/STÄUBEN



19

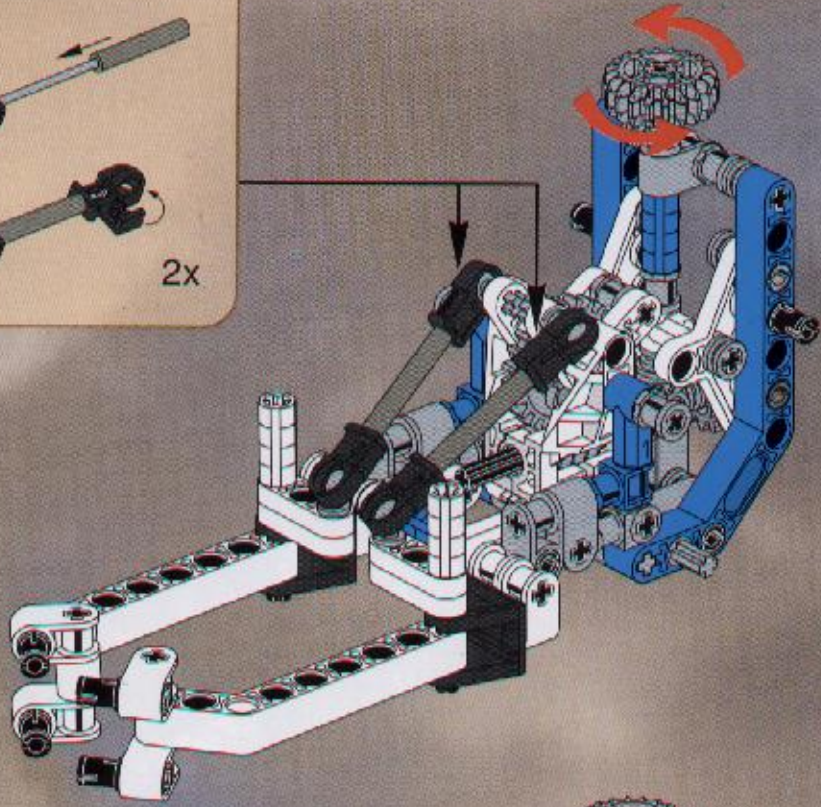
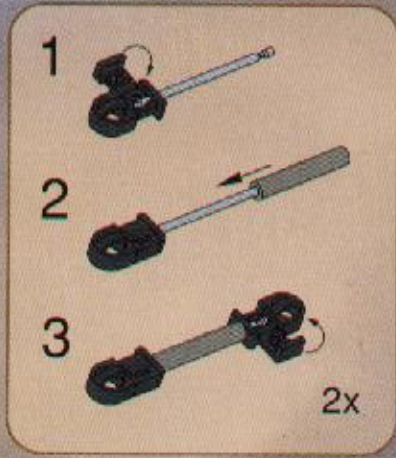
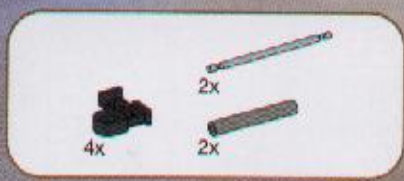

20

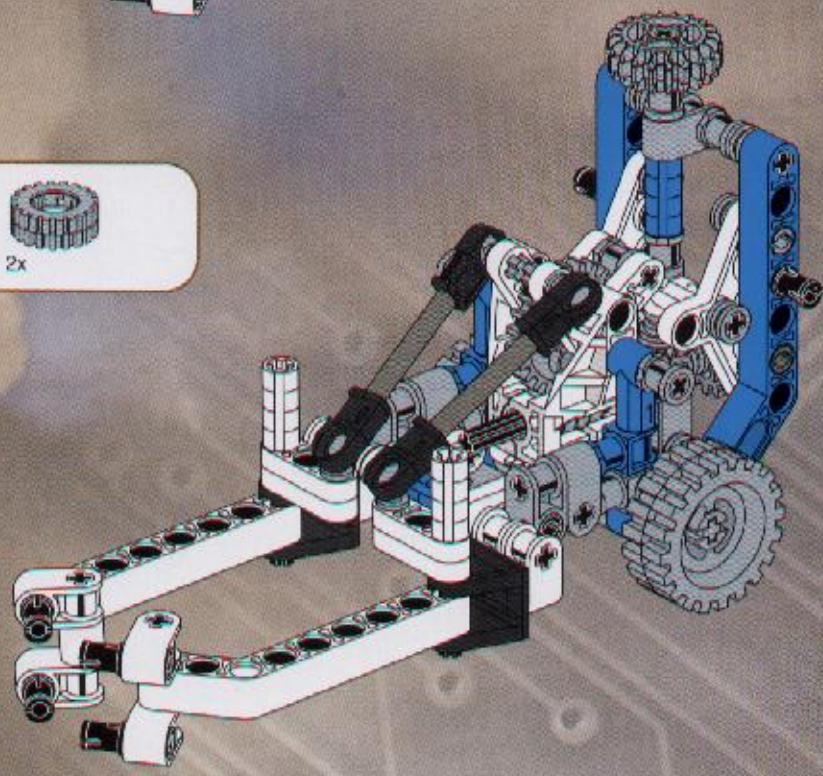
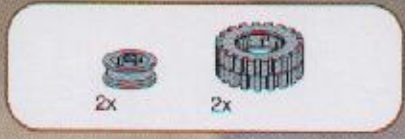



21

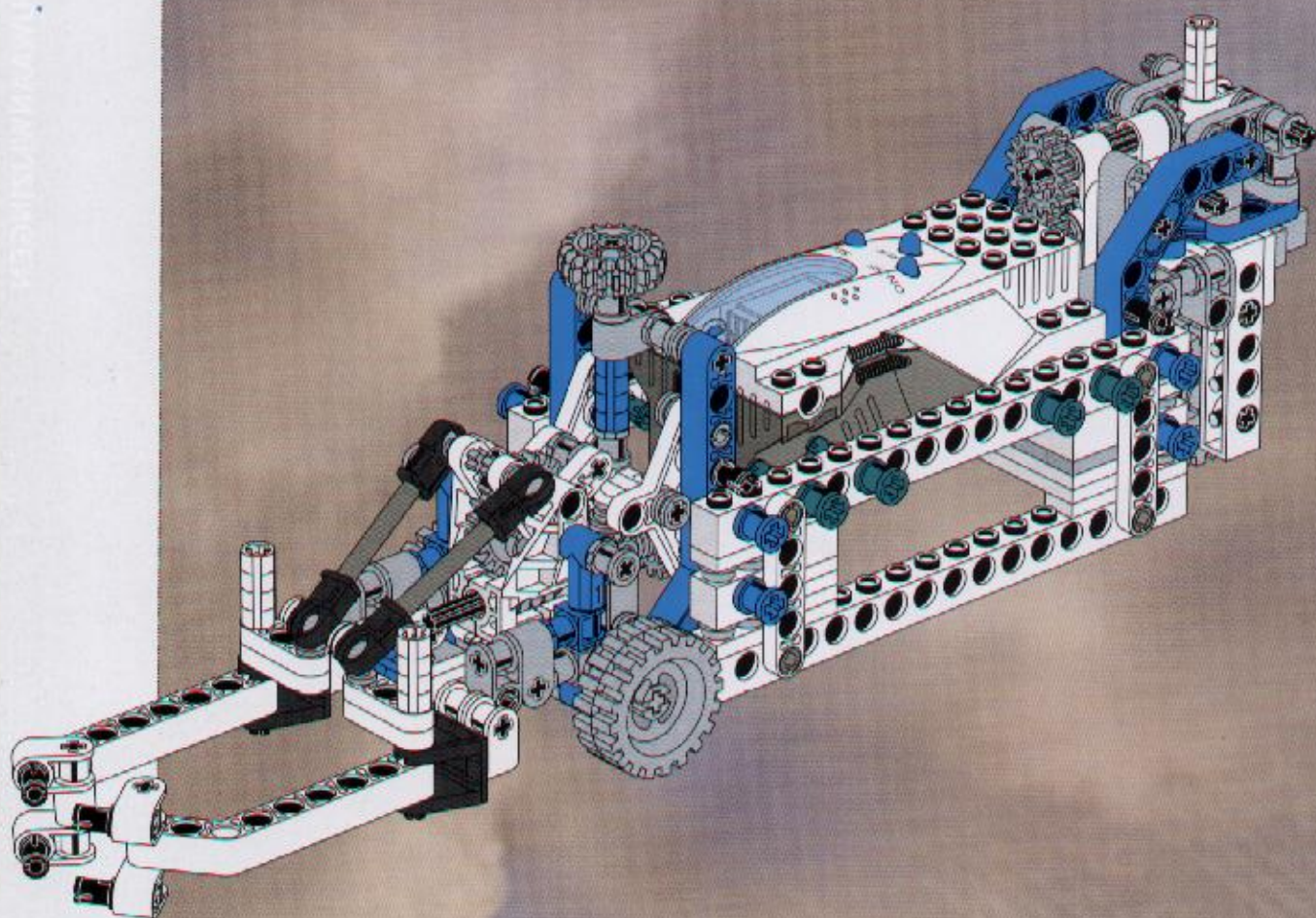

SPECIALE TOEPASSINGEN



VOORBEELDEN VAN DROÏDEN

Hier zijn wat voorbeelden van droïden die je op het Jedi-ridder niveau zelf kunt bouwen.

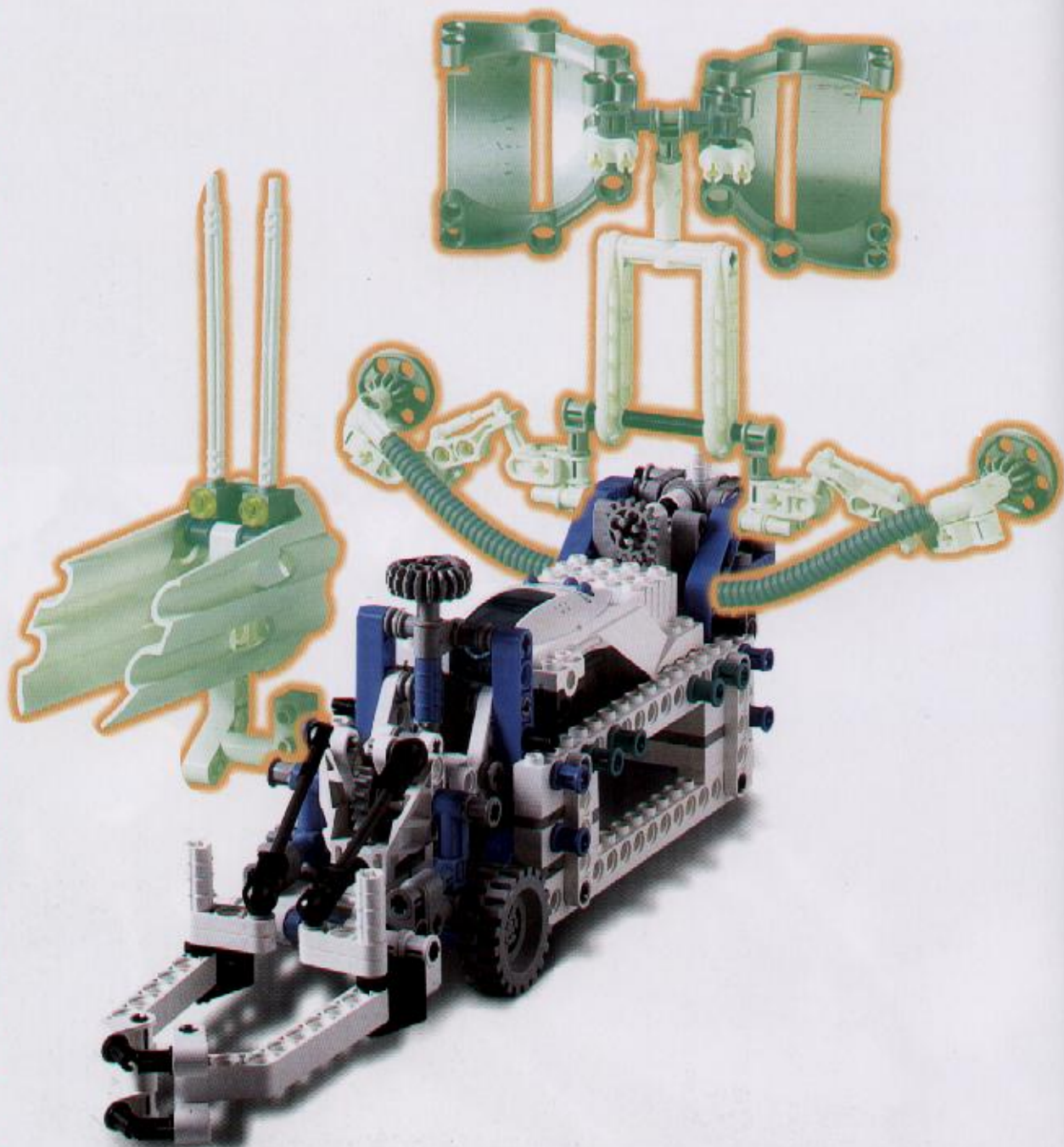

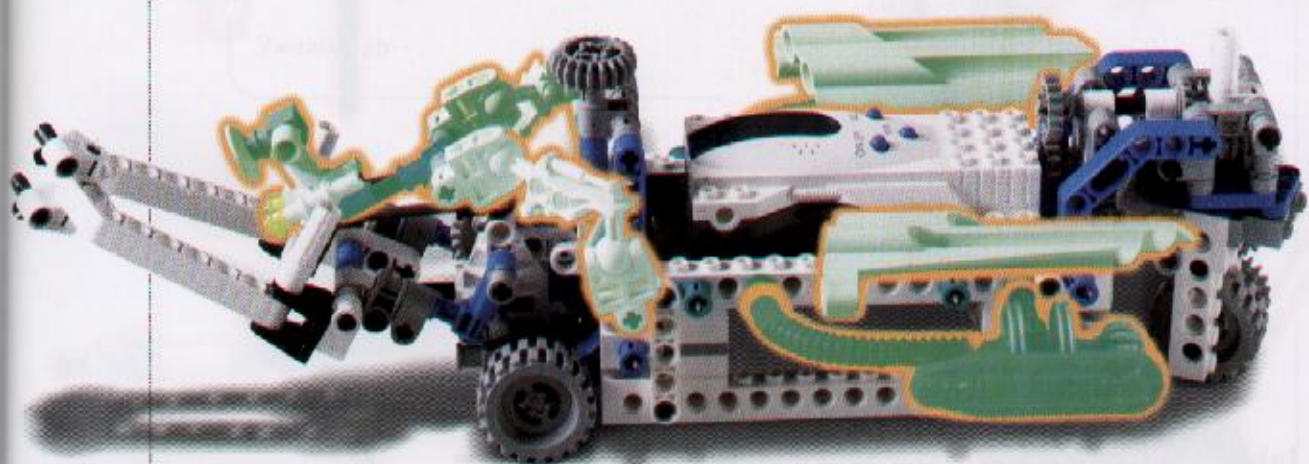
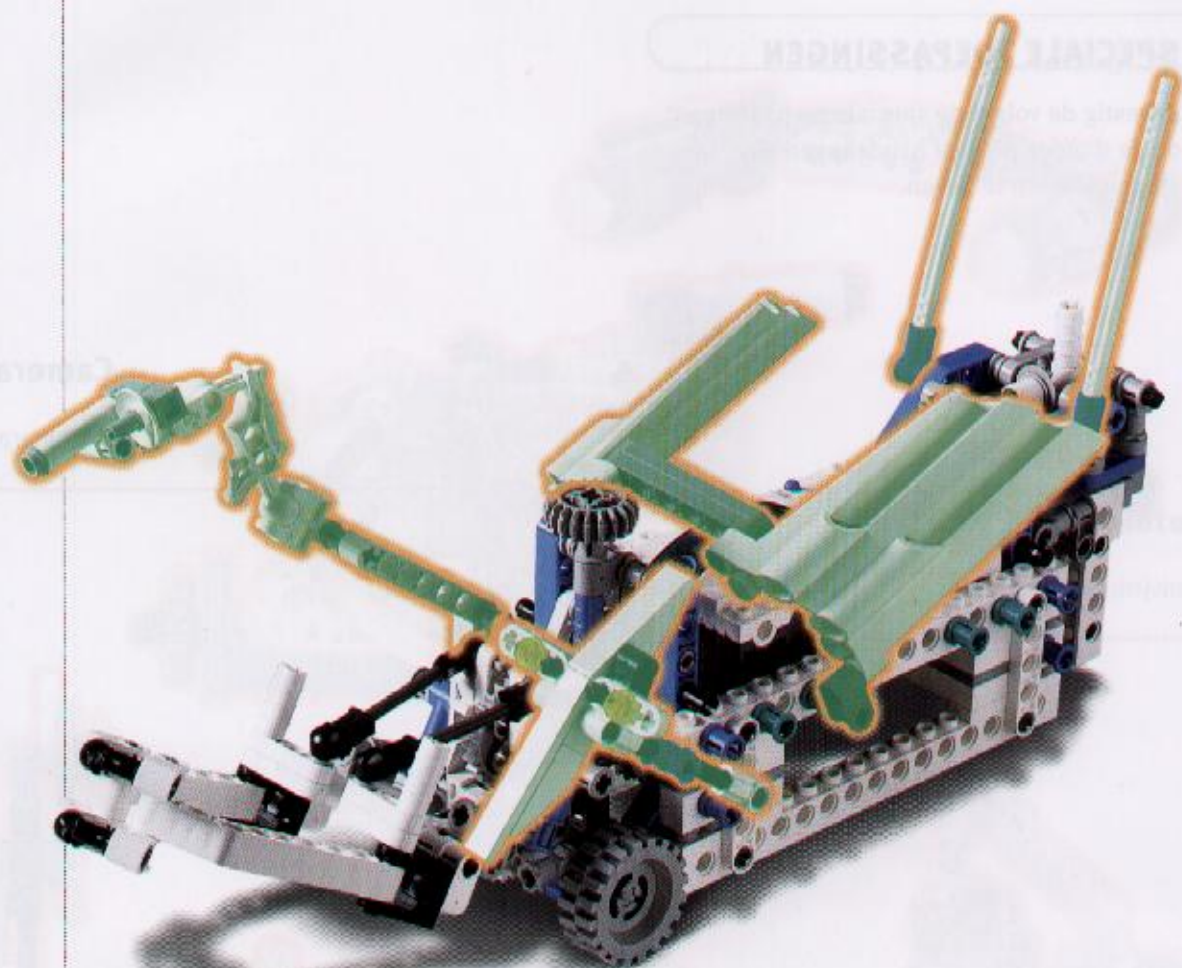

SPECIALE TOEPASSINGEN

Bevestig de volgende speciale toepassingen om je droïden nieuwe handelingen en mogelijkheden te geven.

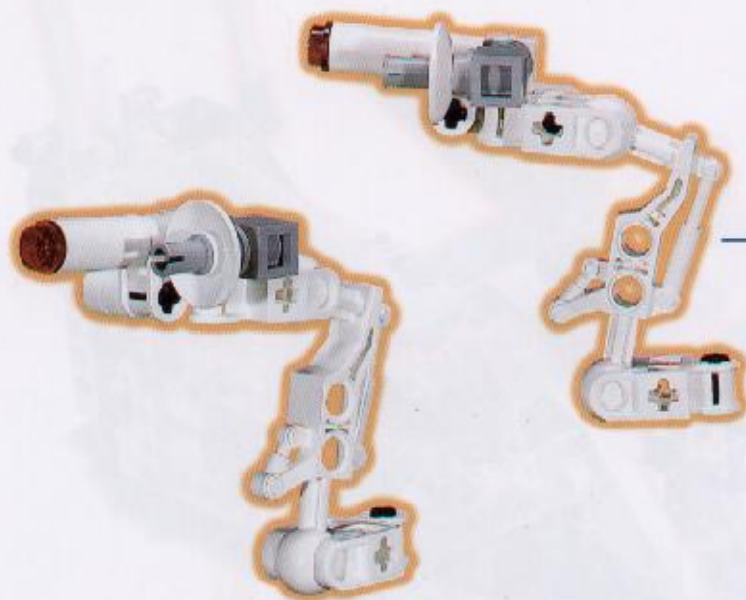

Camera

Telecamera

Kop

Zwaaikop

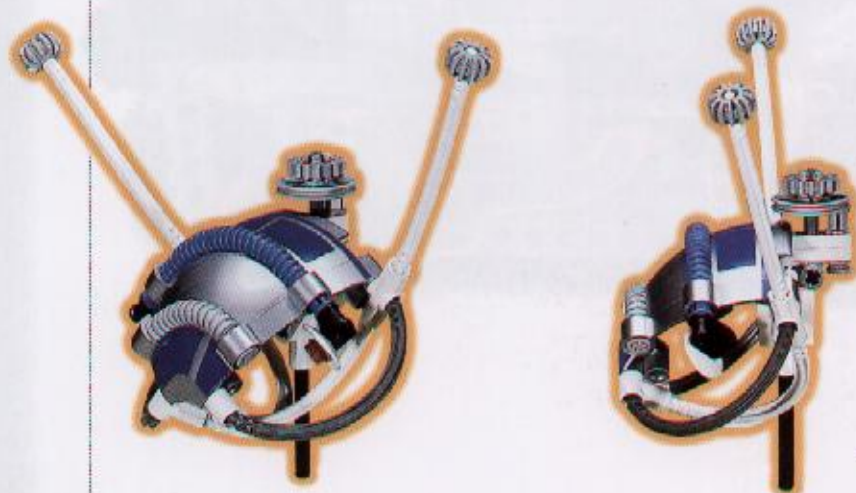

Kop

Insectenkop

TECHNISCHE TOESTANDEN

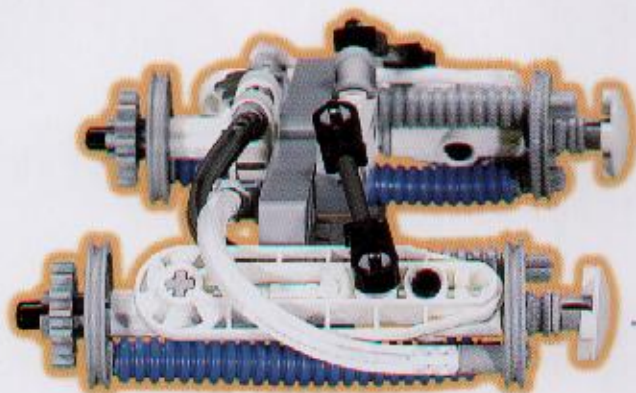
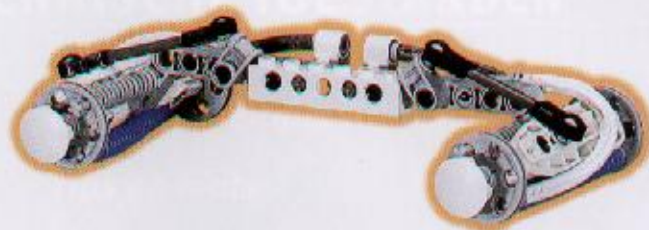

Motor

Ionenstralaandrijving

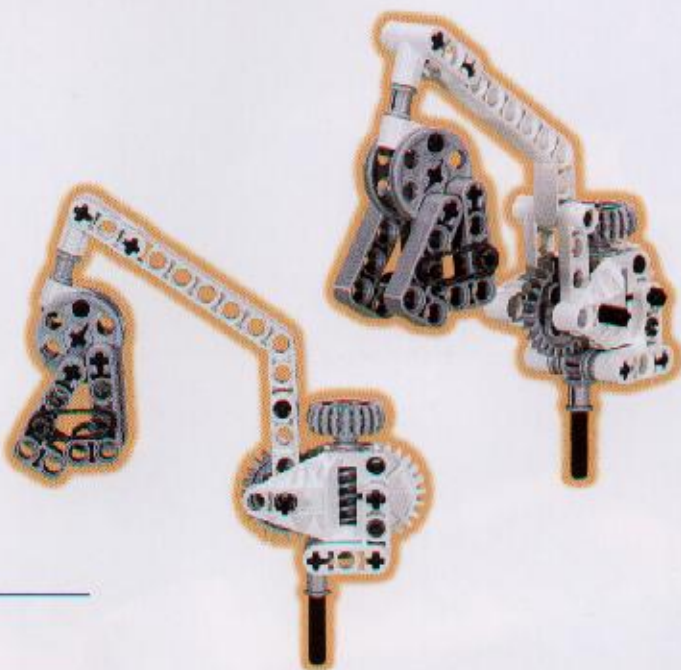

Werktuig

Zwaaikraan

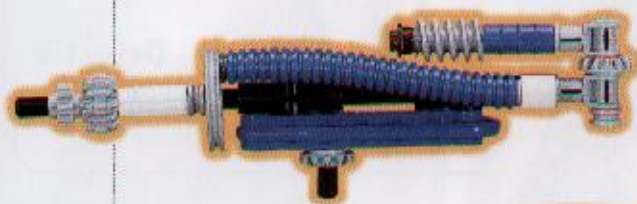

Verdedigingsmiddel

Volglaser

SPECIALE TOEWIJZINGEN

Vliegmiddel

Vleugels



Detectie

Precisieradar



Detectie

Breedbandradar

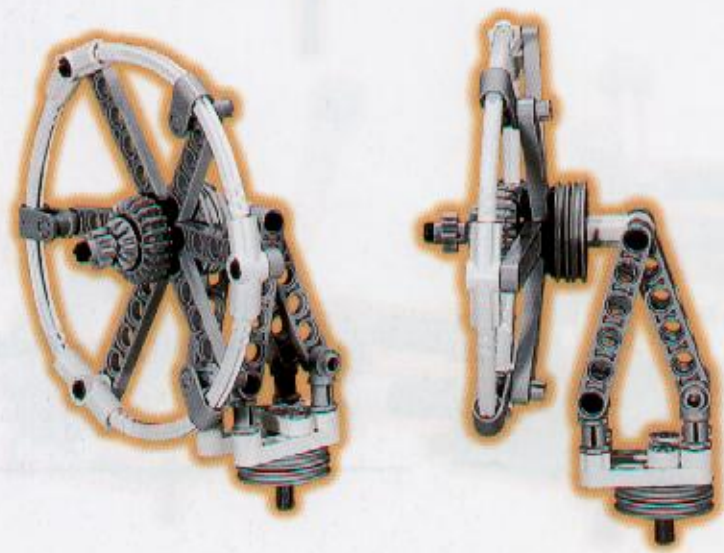

TECHNISCHE TOESTANDEN

Droid™ Developer Kit CD-ROM

Tips en hints

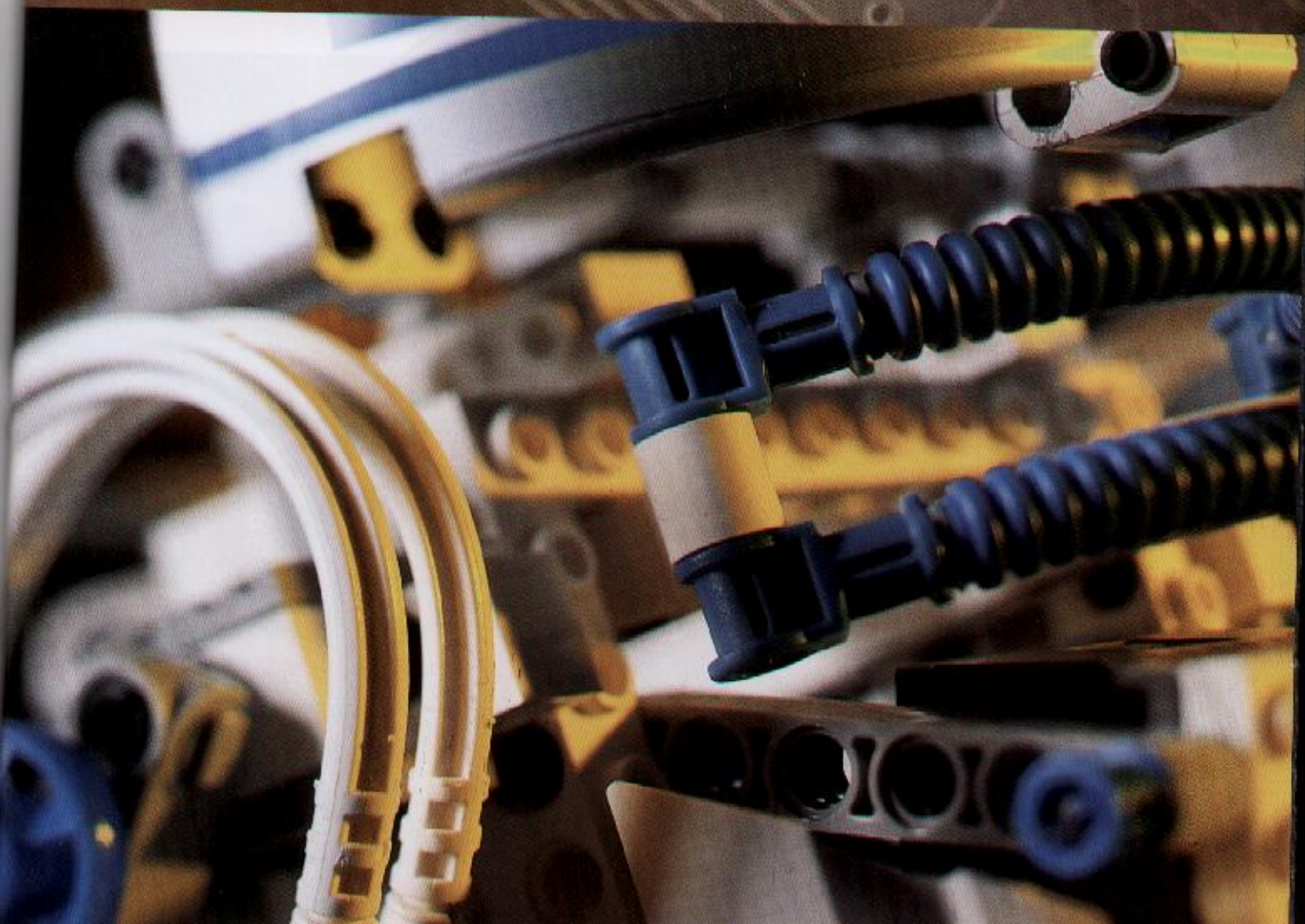

DROID DEVELOPER KIT CD-ROM

Door de uitdagingen op de CD-ROM aan te gaan kun je het tot Jedi-meester brengen in het bouwen van droïden. Er zijn drie niveaus om te voltooien. De schermafbeeldingen op deze pagina's laten wat zien van de avonturen die je te wachten staan.



R2-D2™ bouwstap van het leerlingniveau.



Leerlingniveau waar je leert hoe je L-3G0 en R2-D2™ kunt bouwen.



Jedi-ridder niveau.

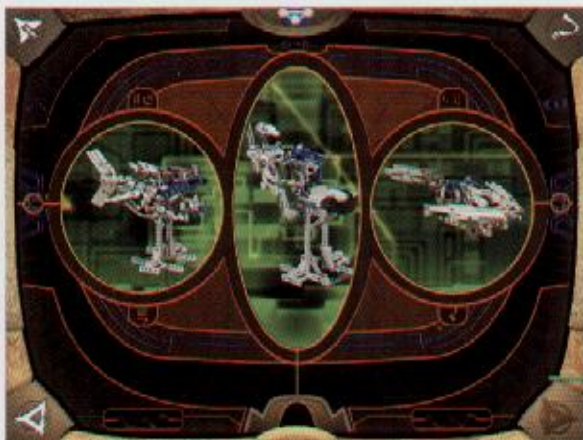

Jedi-meester niveau.

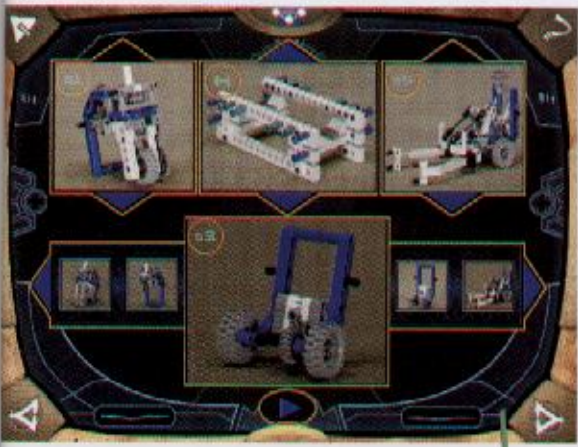

De technische bestanden met informatie over alle speciale toepassingen, frames en modules voor de droiden.



Micro Scout leersysteem



Als je de werkbalk niet ziet, kun je op Ctrl + D drukken om het laatste gebruikte gereedschap te herstellen, op Ctrl + K om het laatste gebruikte gereedschap te behouden en op Ctrl + M om het laatste gebruikte gereedschap te herstellen.

TIPS EN HINTS

Zó kun je sterkere, grotere en betere droïden maken.

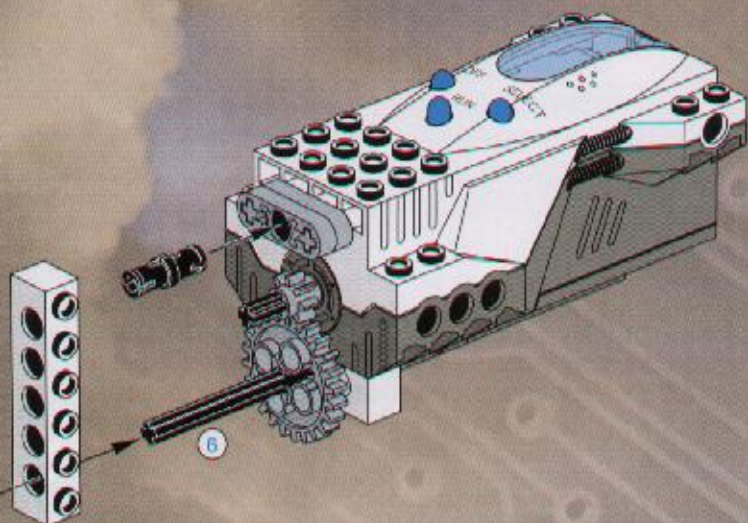
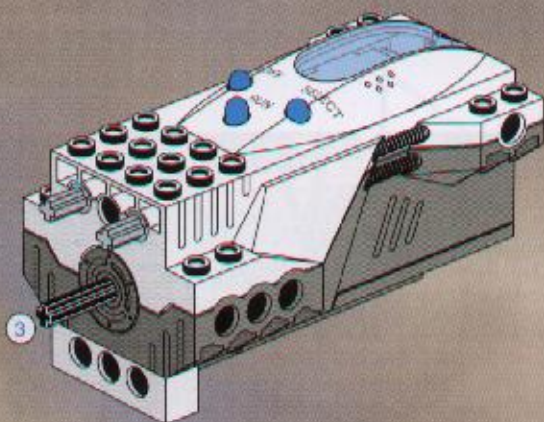
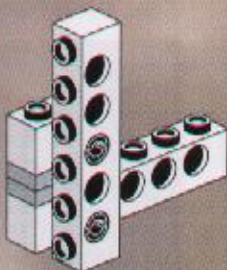

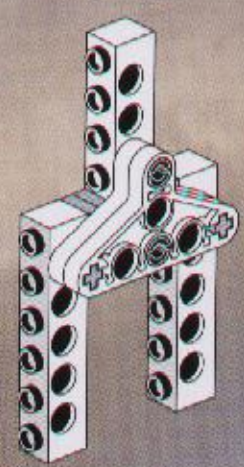
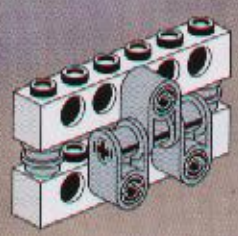

1

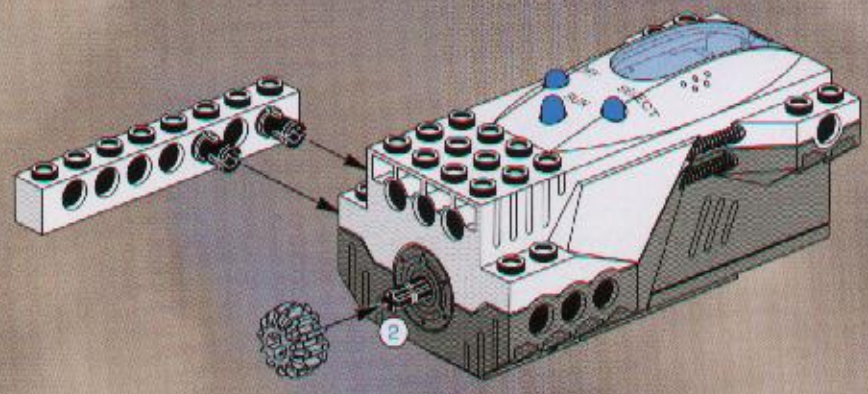

2

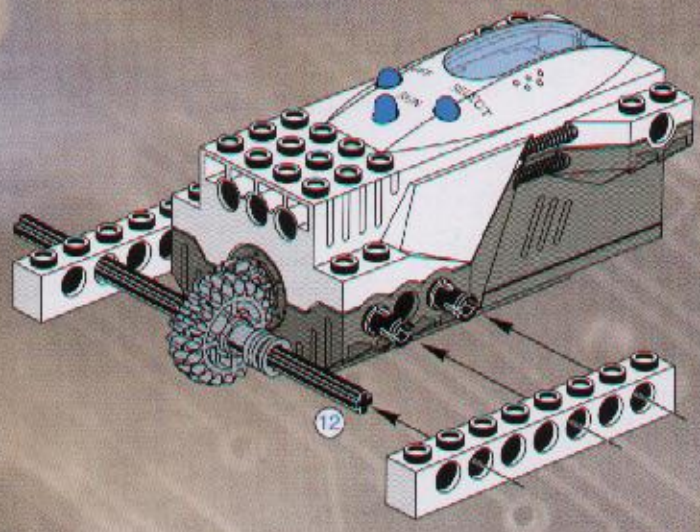

1

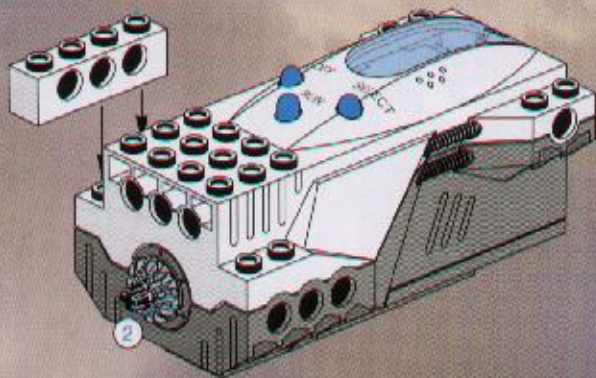

2

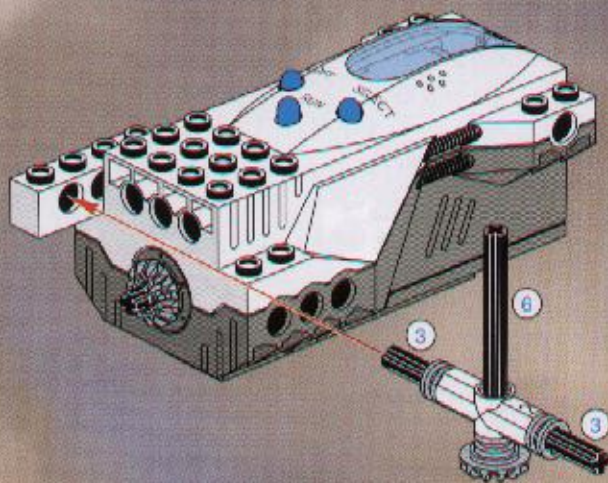

3

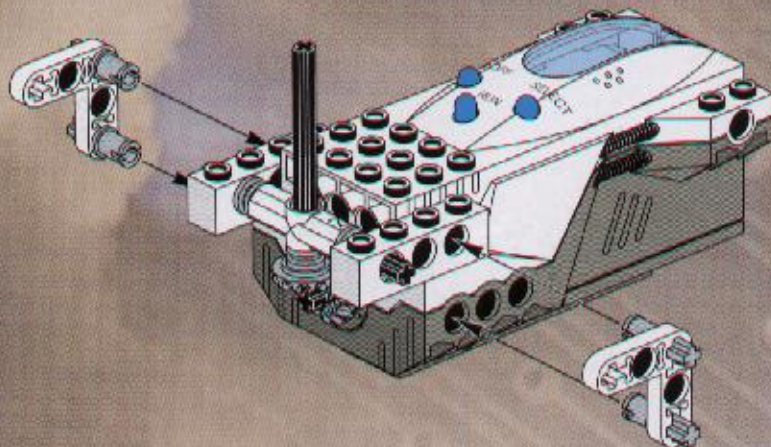

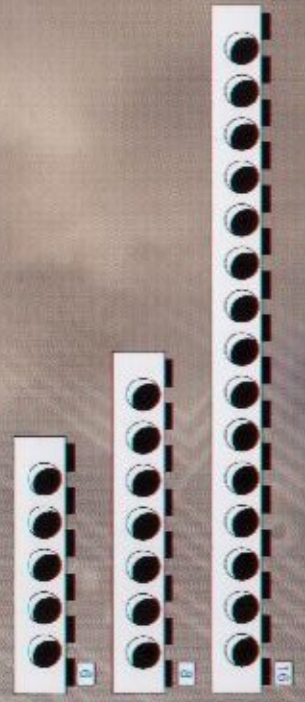
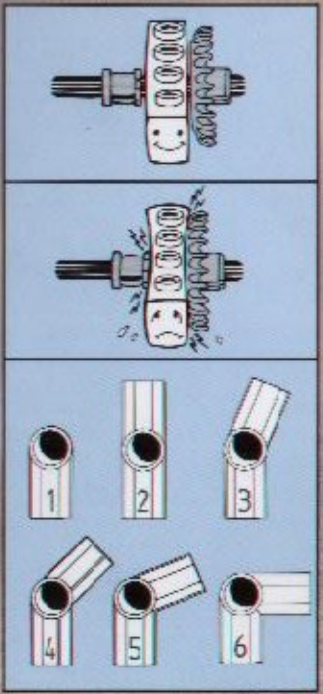
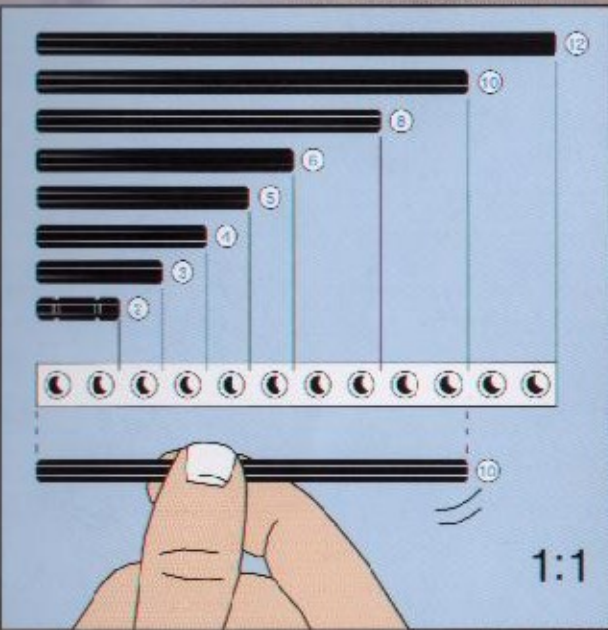
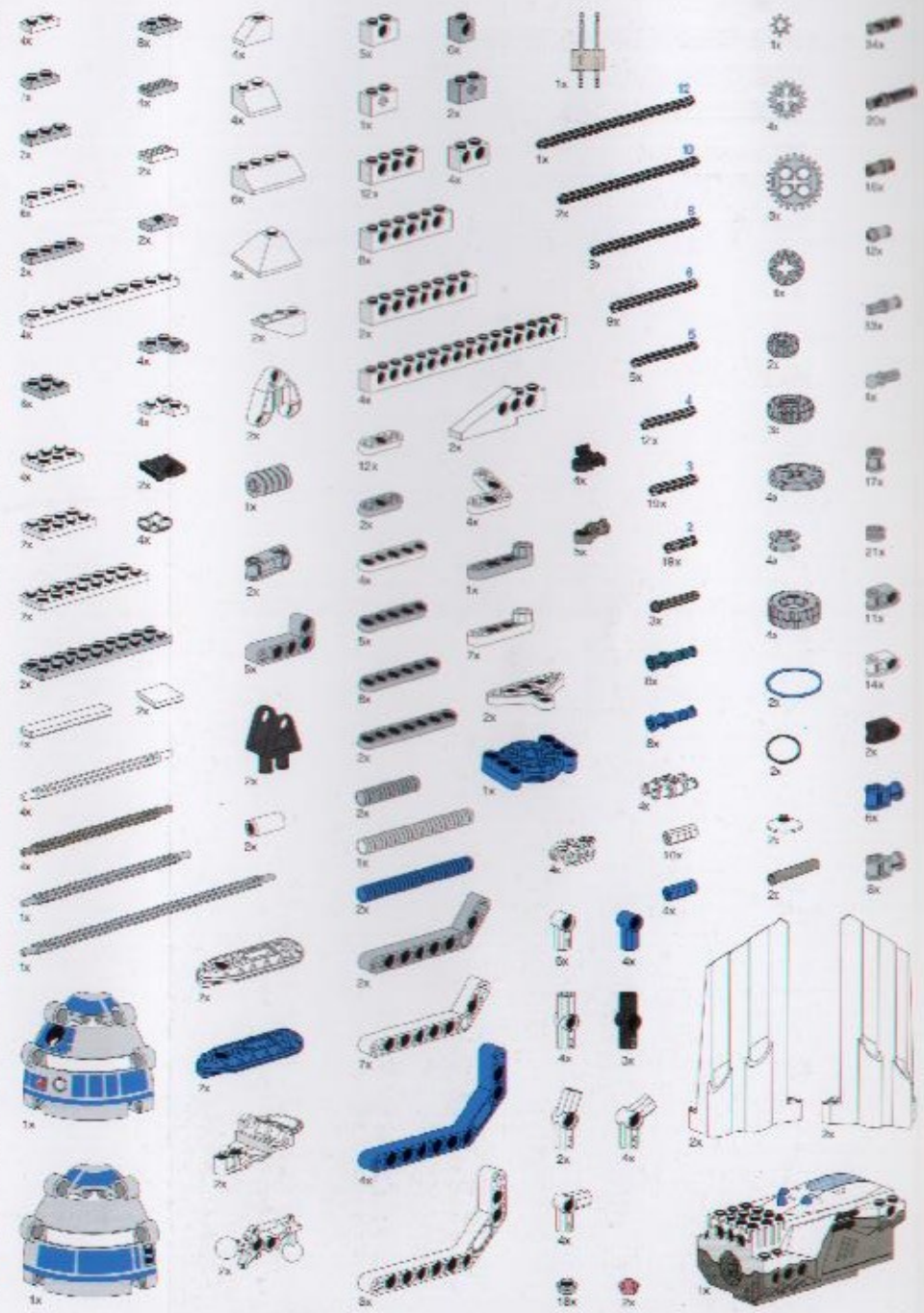

The logo features the word "LEGO" in white on a red square background, followed by "MINDSTORMS" in a bold, blue, sans-serif font with a white outline. The background of the entire page is a dramatic, dark sky with swirling brown and blue clouds, and a faint, glowing circuit board pattern in the lower right corner.

LEGO MINDSTORMS