

LEGO

9479

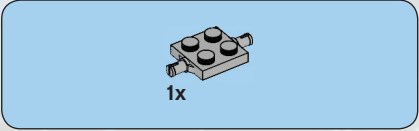

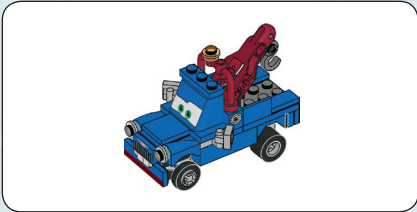

1

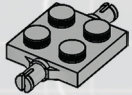

2

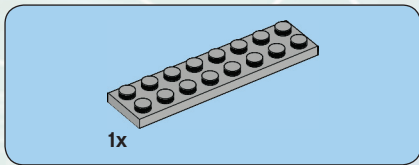

2

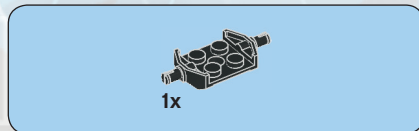
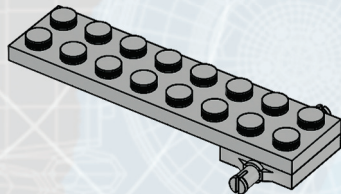

3

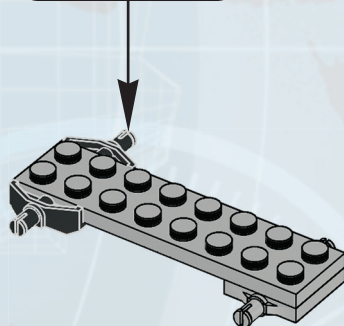
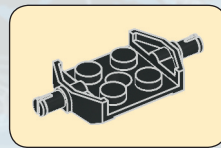

3

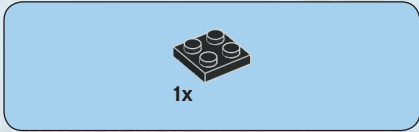

4

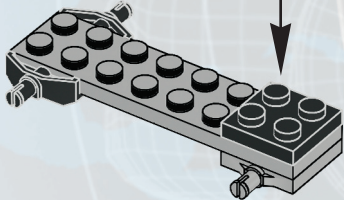
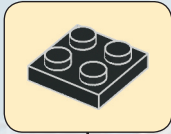

4

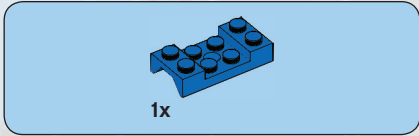

5

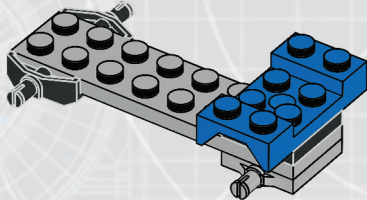

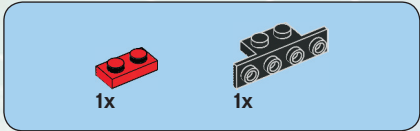

2

target
acquired

6

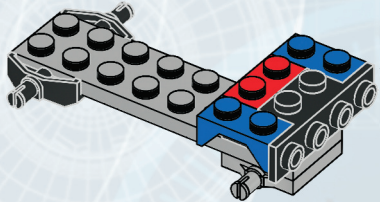
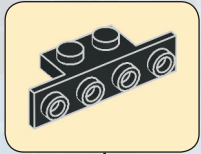

5

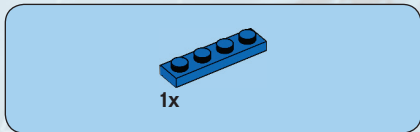

7

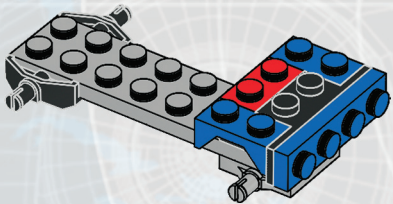
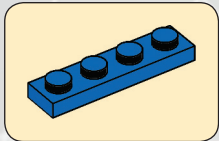

6

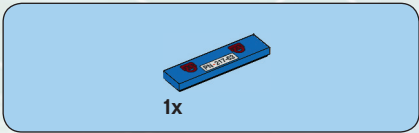

8

2
target
acquired

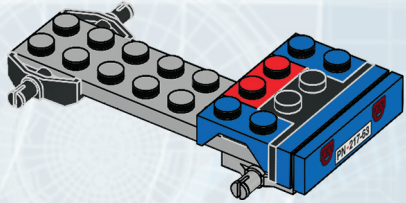
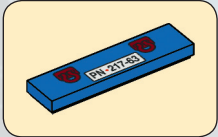

7

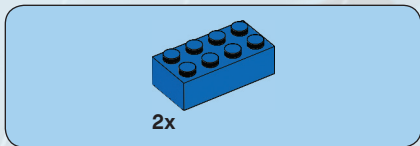

9

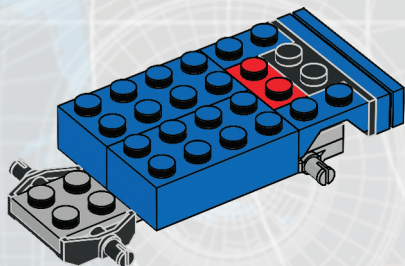

8

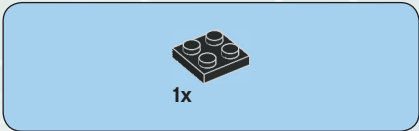

10

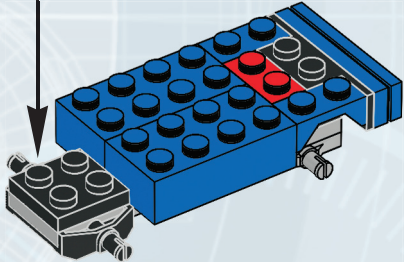
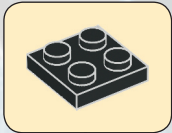

target
acquired



1x

11

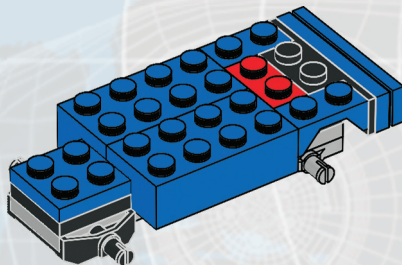

10

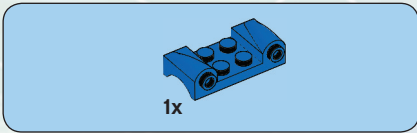

12

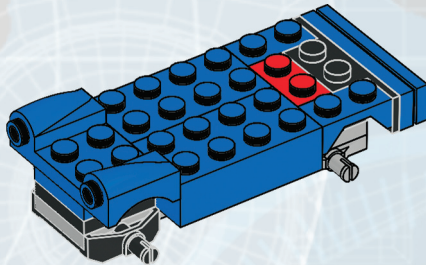

11

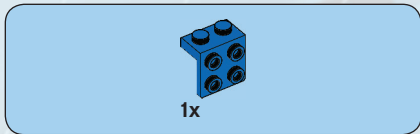

13

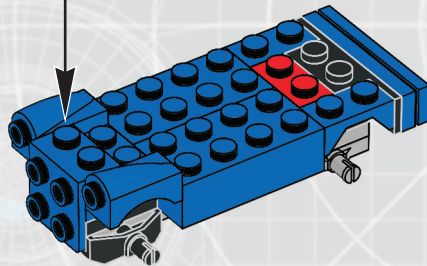
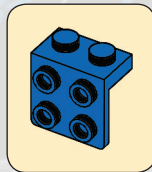

12

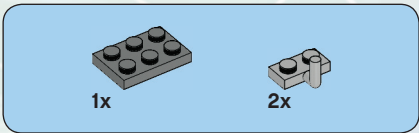

target
acquired

2

14

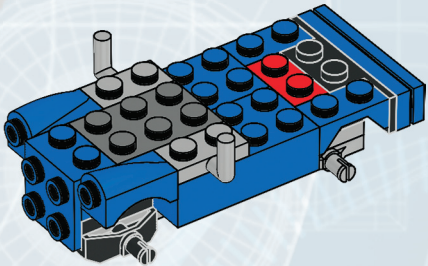

13

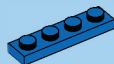

1x



1x

15

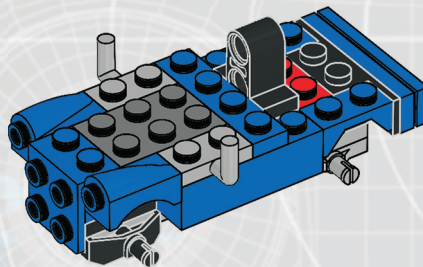

14

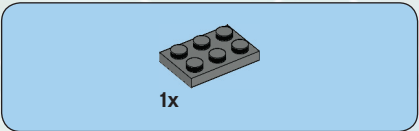

16

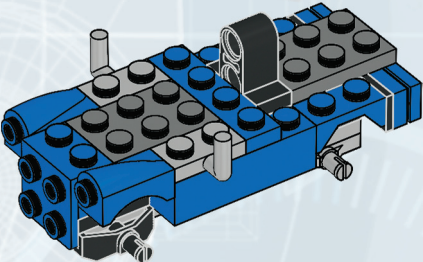

15



2x

17

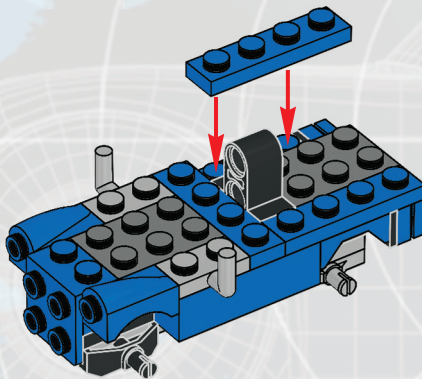

16



*target
acquired*

18

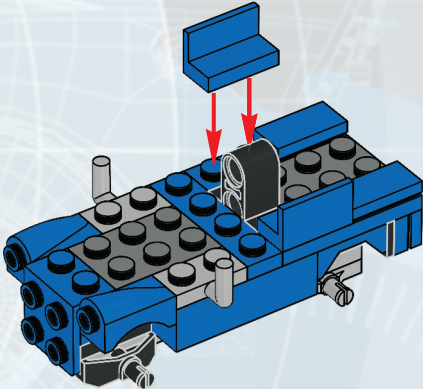

17

2x

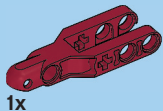

1x

1

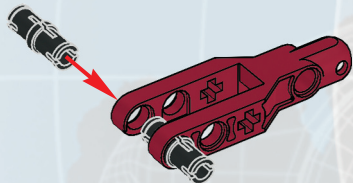

2x

2

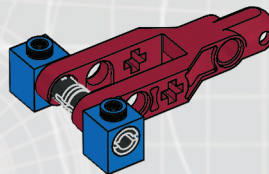

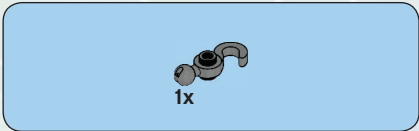

3

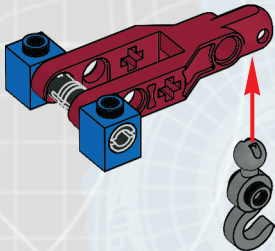

19

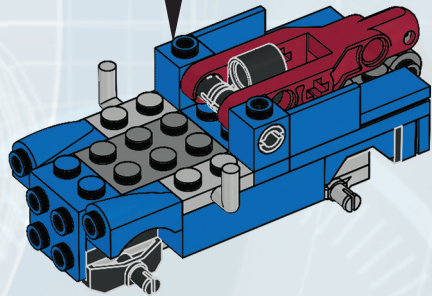

19

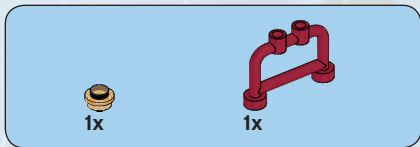

20

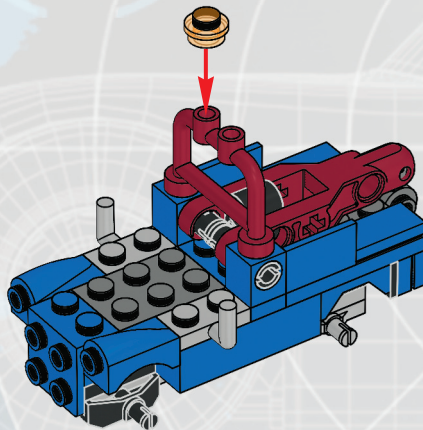

20

2x

2

*target
acquired*

21

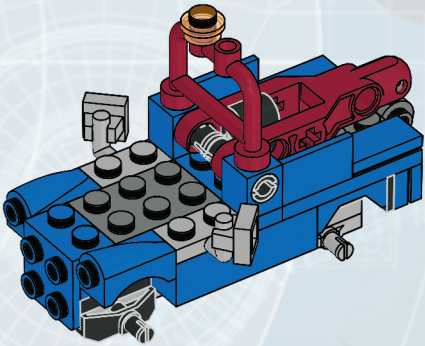

21

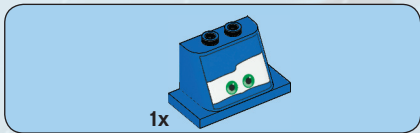

22

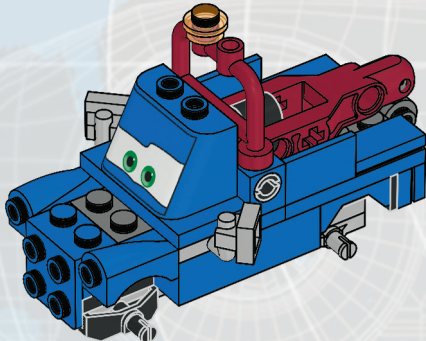

22

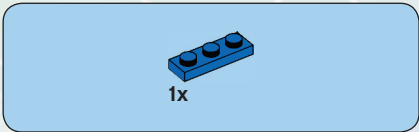

23

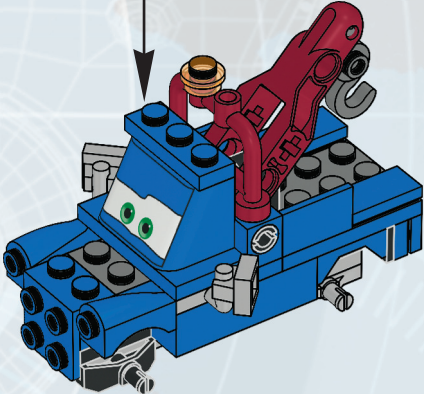
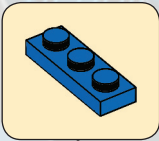

23



1x



2x

24

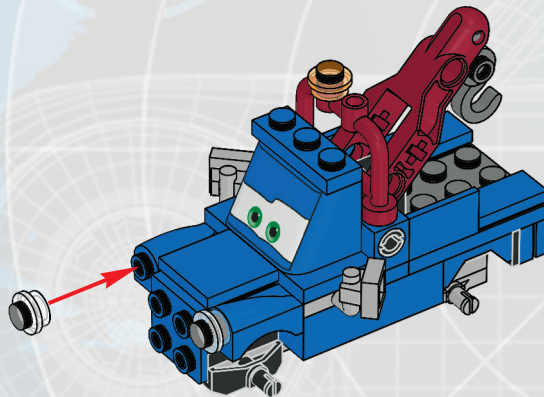

24



2

*target
acquired*

25

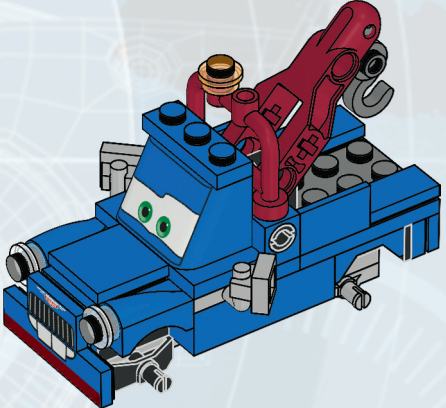

25



26

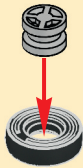
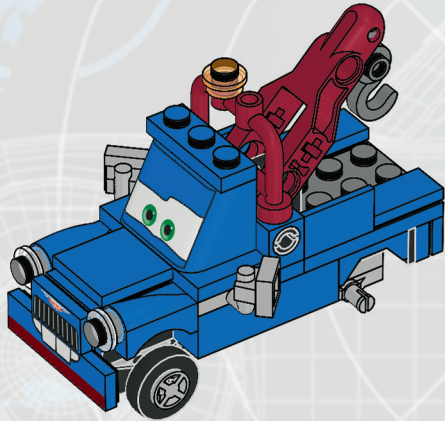

2x

26

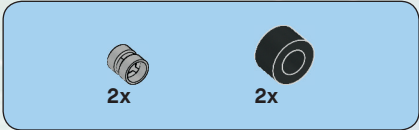

27

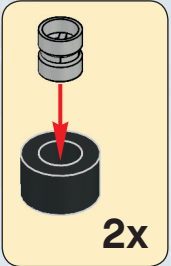
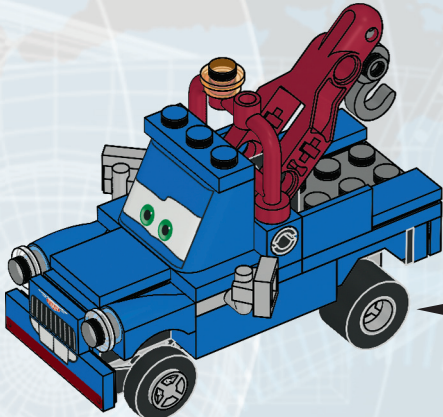

target
acquired

2

27

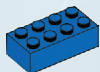

2x
300123



2x
4119014



1x
302223



2x
306923



4x
371023



1x
4505907



1x
4654801



1x
4654802



1x
4654803



1x
4600182



2x
486523



1x
4651003



1x
4654804



1x
362323



1x
306823



1x
302321



2x
302226



1x
4144024



1x
4282746



1x
615726



2x
4508215



2x
4516843



2x
4121715



2x
3005740



1x
4222960



2x
4211369



2x
4611702



1x
4211504



2x
4211506



2x
4211765



1x
4651007



1x
4264795



2x
4211043



1x
4211406



1x
4212529



Customer Service

Kundenservice

Service Consommateurs

Servicio Al Consumidor

www.lego.com/service or dial



00800 5346 5555 :



1-800-422-5346 :



2011



8639



8423, 8639, 8679



8426



8487



8200, 8487



8487



8206, 8484, 8679



8206, 8679



8487



8424



8639



8423, 8679



8638



8638



8487



8638



8638



8638

2011



8201, 8487



8639



8639



8486



8426, 8639



8639



8426



8638



8486



8679



8679



8679



8679



8424

2012



9486



9485



9486



9481



9480



9483



9484



9485



9479



9484



9486



9483



9486



9485



9486



9485



9478





WIN!

Go to www.LEGOsurvey.com/product
to fill out a survey for a chance
to win a cool LEGO® Product.
No purchase necessary.
Open to all residents where not prohibited.



www.LEGOsurvey.com/product

GEWINNE!

Nimm an der Umfrage auf www.LEGOsurvey.com/product teil und hab die Chance ein cooles LEGO® Produkt zu gewinnen! Die Teilnahme am Gewinnspiel führt zu keinerlei Kaufverpflichtungen. Teilnahme in allen nicht ausgeschlossenen Ländern möglich.

WIN!

Ga naar www.LEGOsurvey.com/product, vul een enquêteformulier in en maak kans op een cool LEGO® product. Geen aankoopverplichting, iedereen mag deelnemen, uitgezonderd ingezetenden van landen waar een enquêteverbod geldt.

GAGNE!

Visite www.LEGOsurvey.com/product pour répondre à un questionnaire et avoir une chance de gagner un produit LEGO® très cool ! Aucune obligation d'achat. Ouvert à tous les résidents des pays autorisés.

当てよう!

www.LEGOsurvey.com/product にアクセスして、アンケートにご記入ください。当選者にはレゴ製品を差し上げます。お買い上げの必要はありません。禁止されていない限り、すべての皆様にご利用いただけます。



www.LEGO.com

6003651

LEGO and the LEGO logo are trademarks of the LEGO Group.
©2012 The LEGO Group. © Disney/Pixar