



POWER MINERS

8961



1

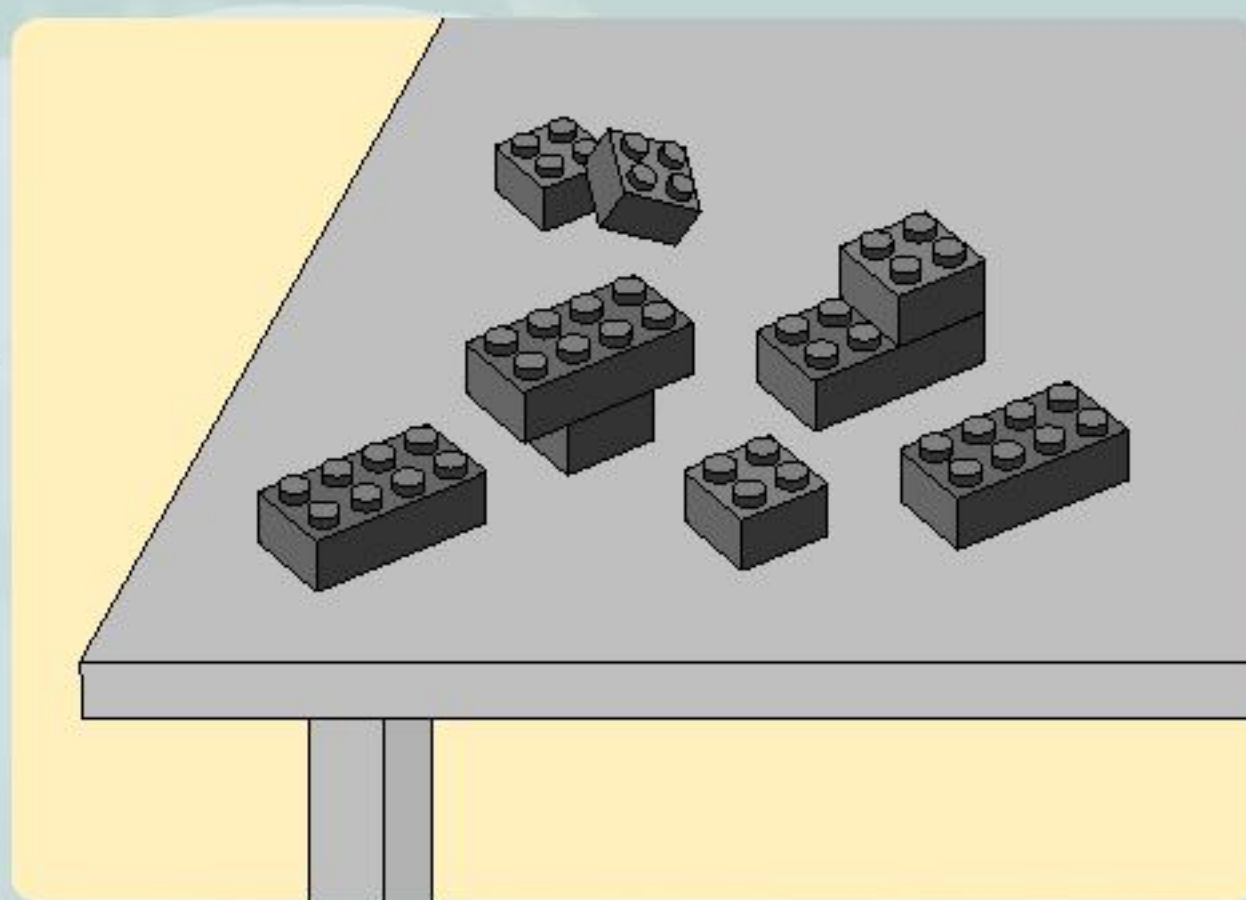
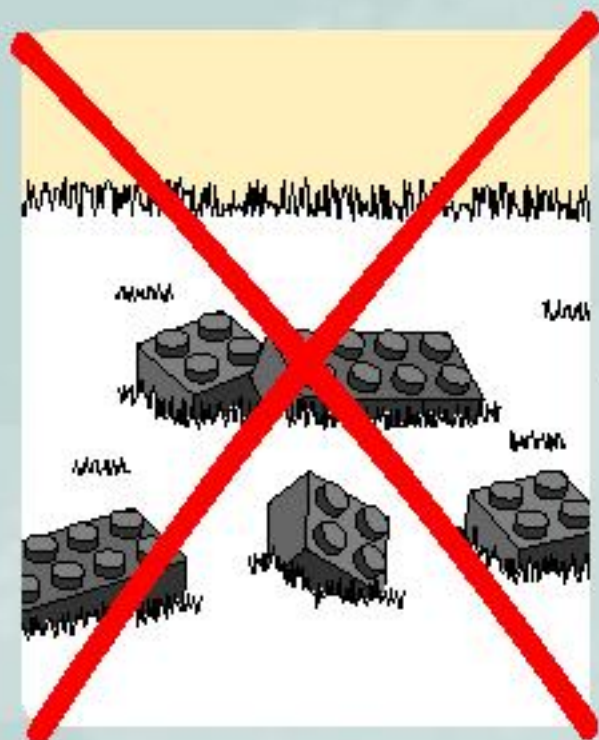

2



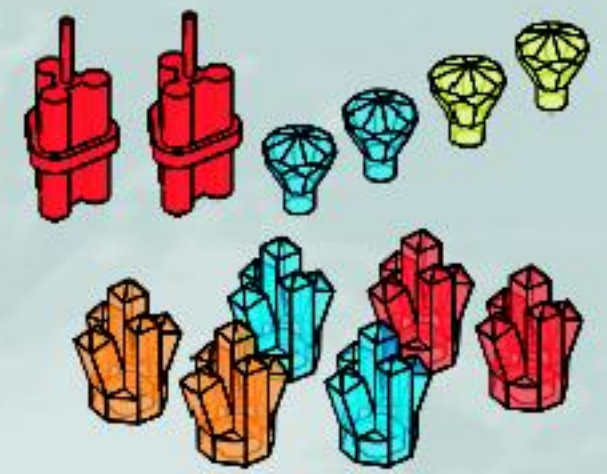
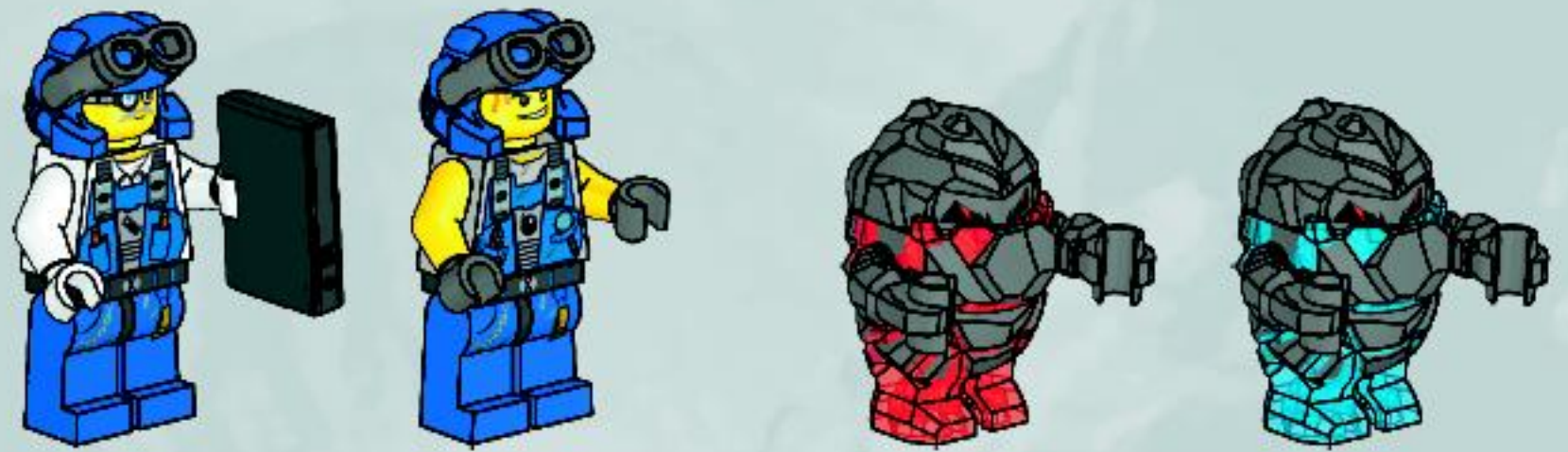
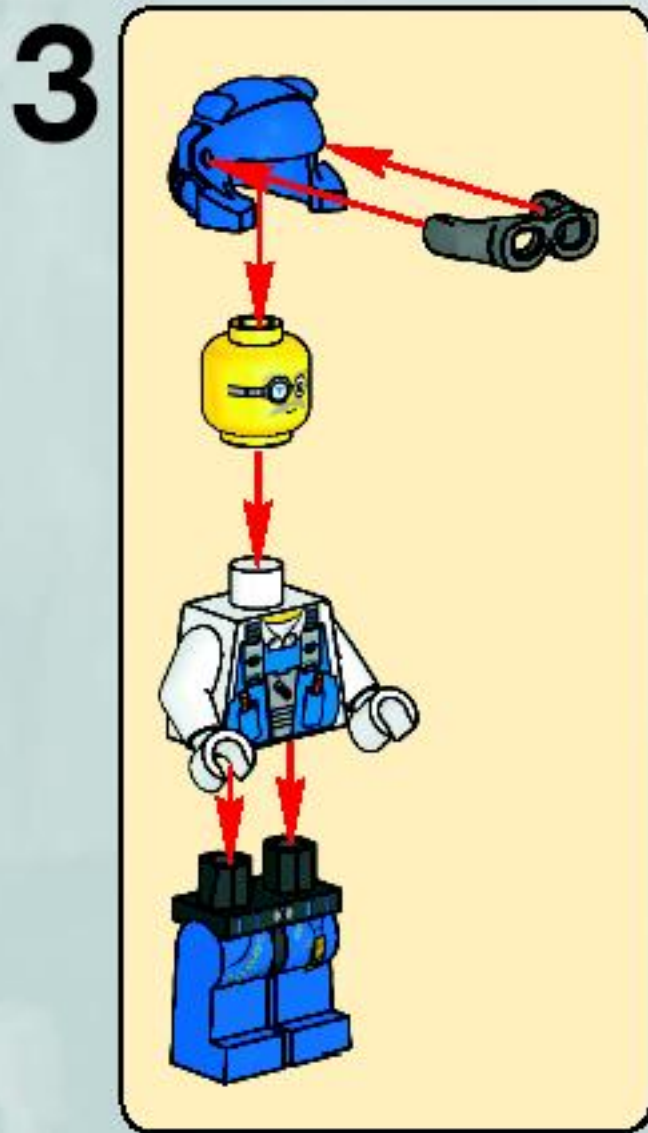
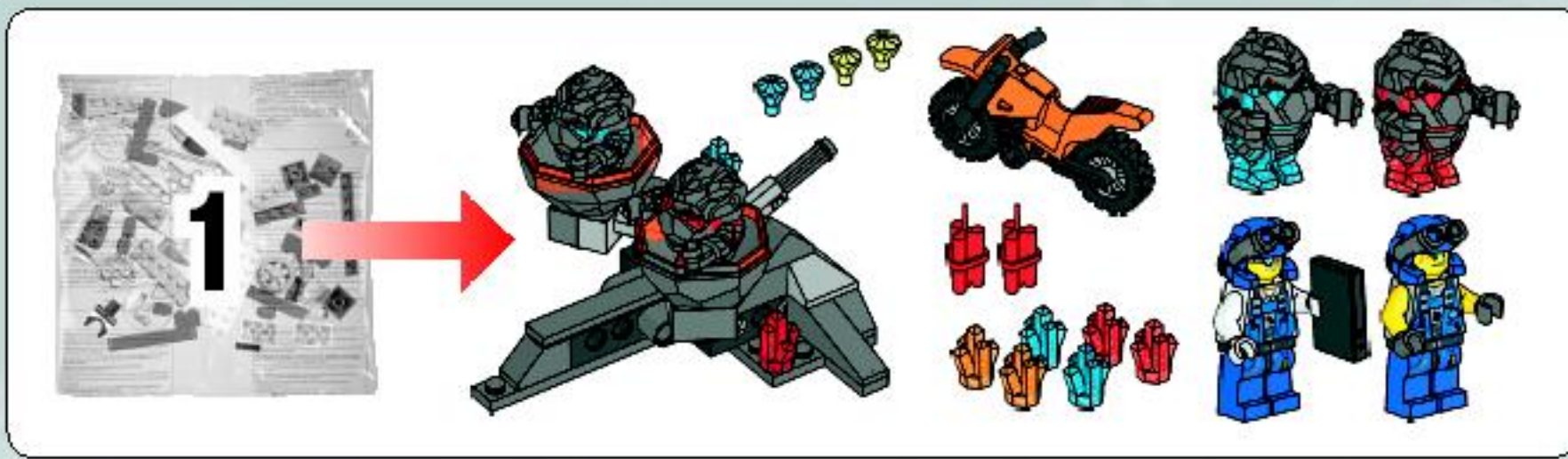

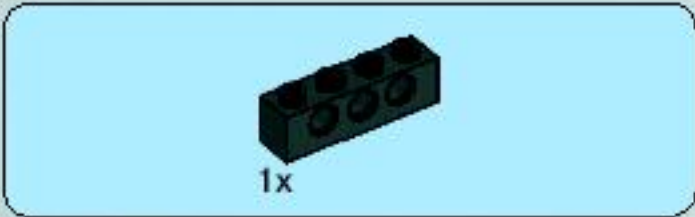
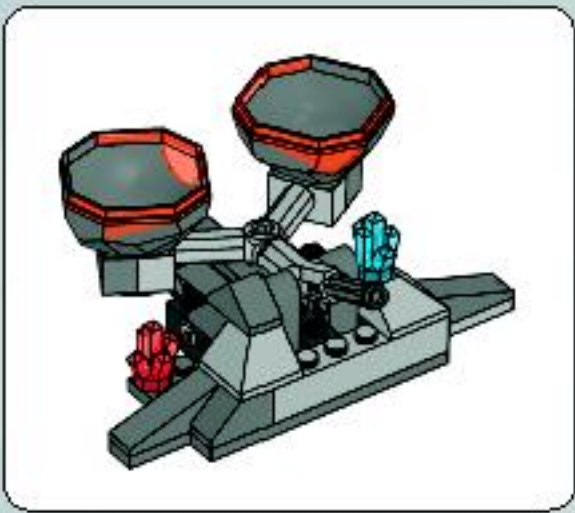

1



2

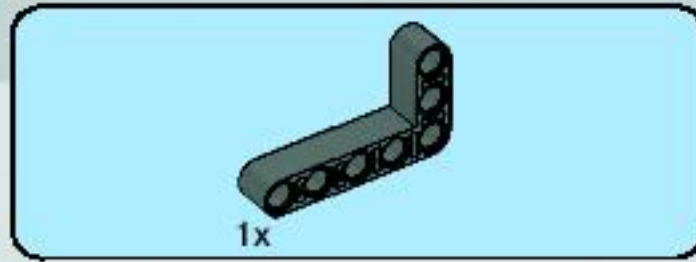
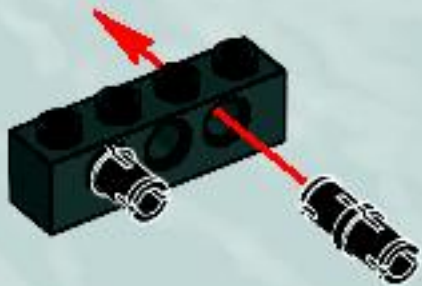

3

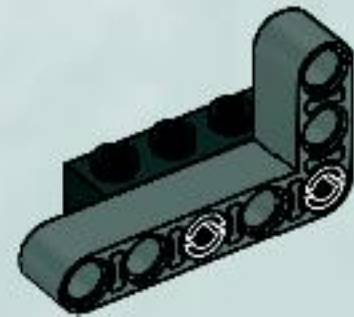

4

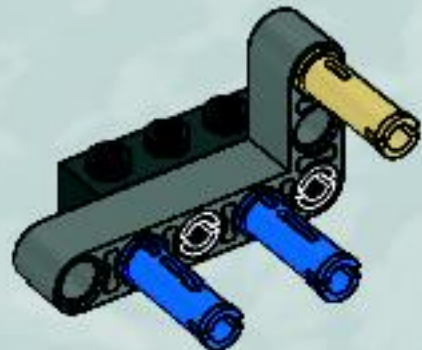

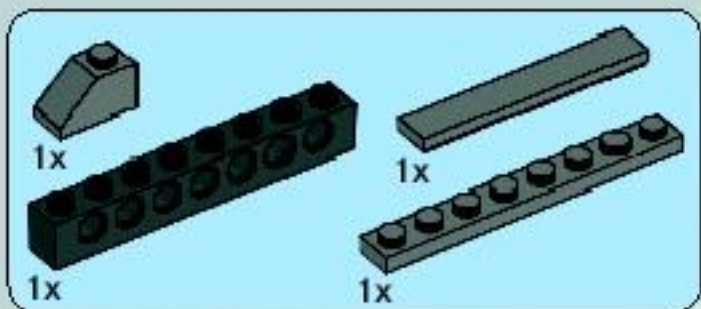

5

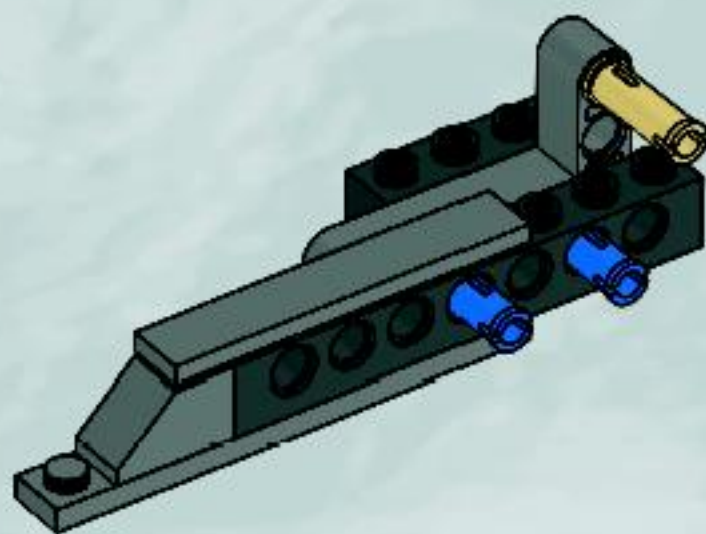
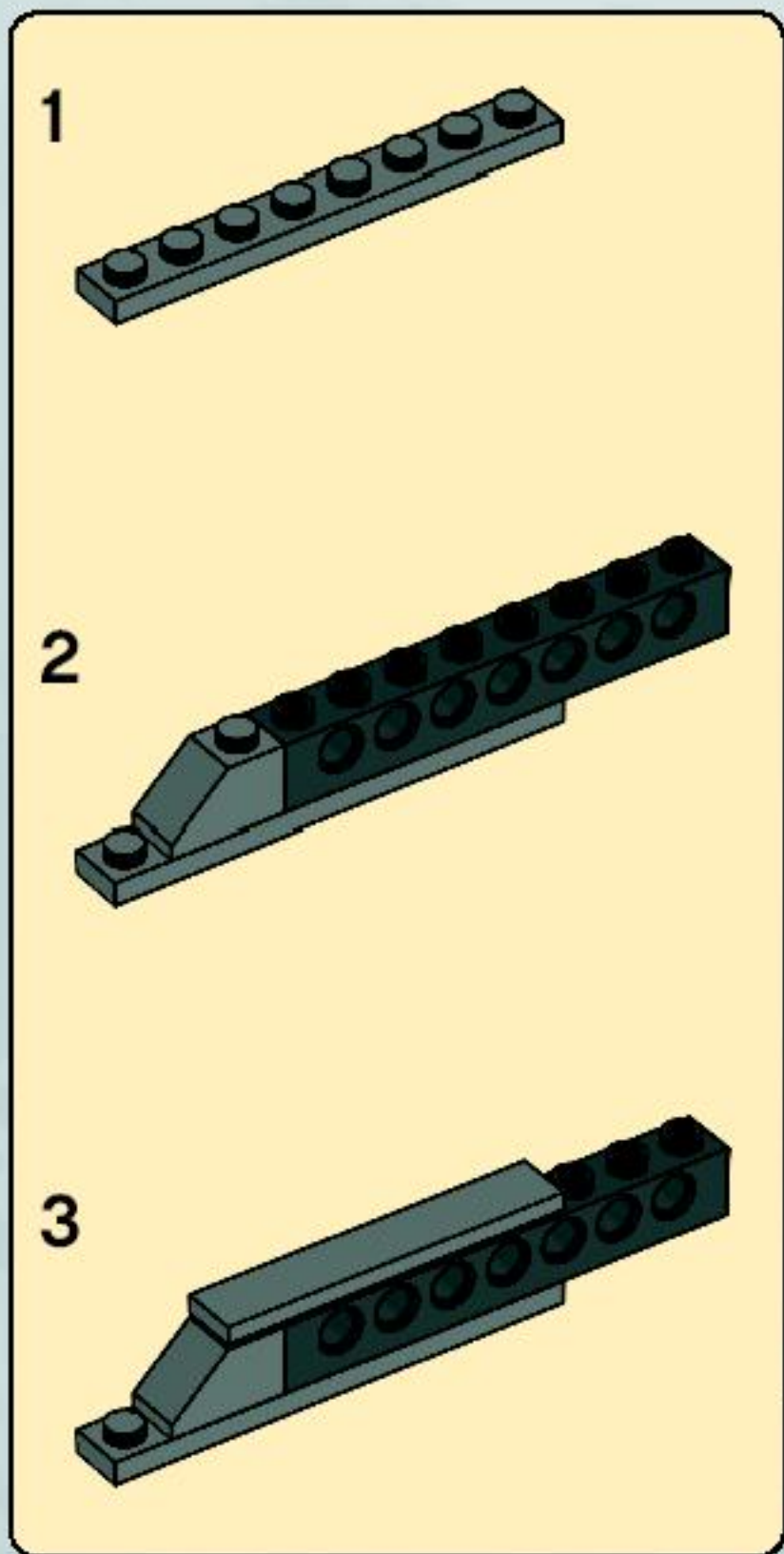



1x

6

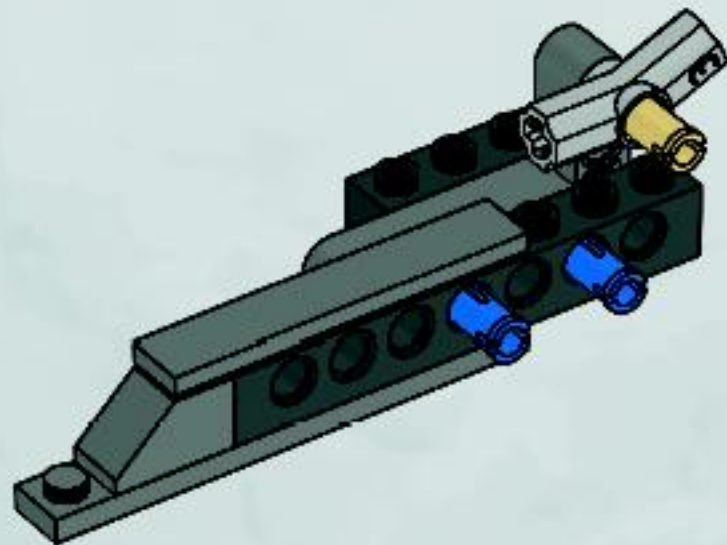

2x

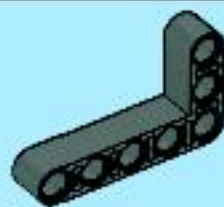

1x

7

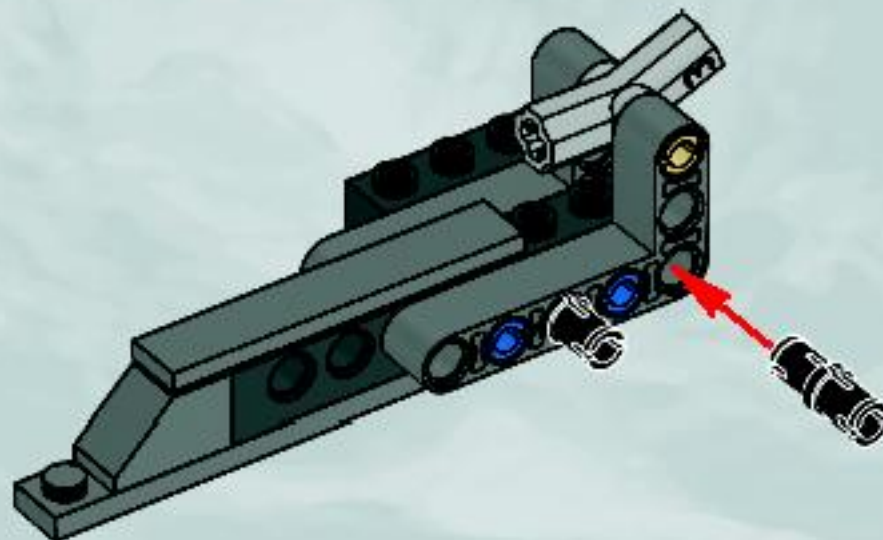



8

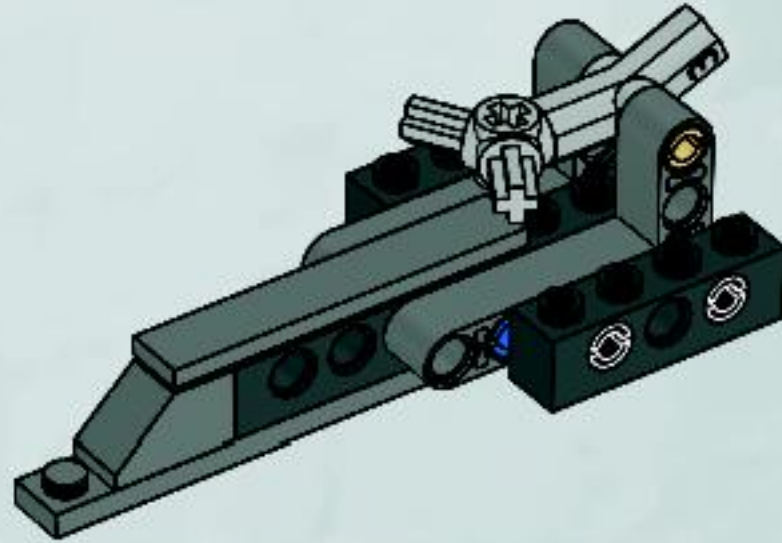

9

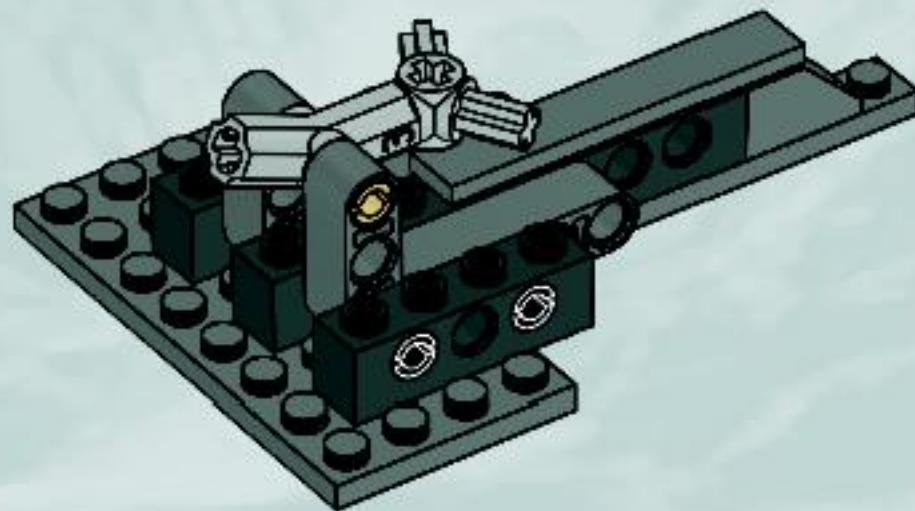

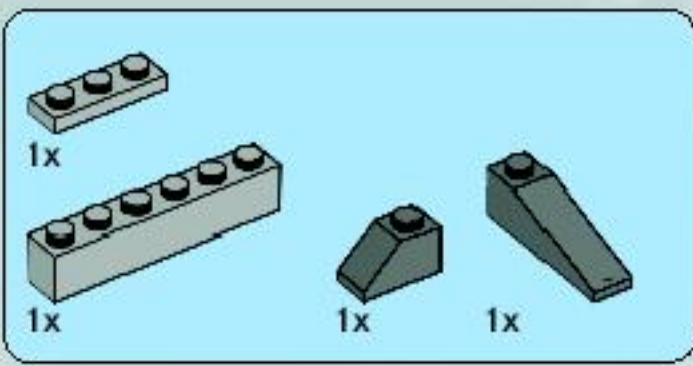

10

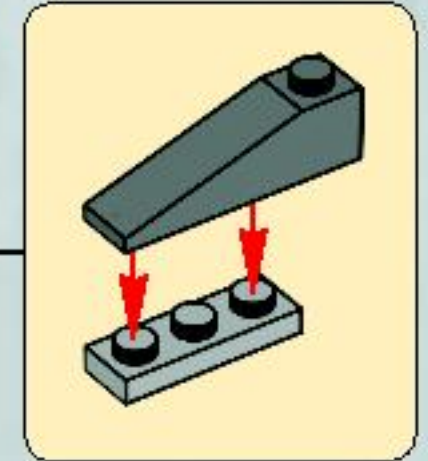
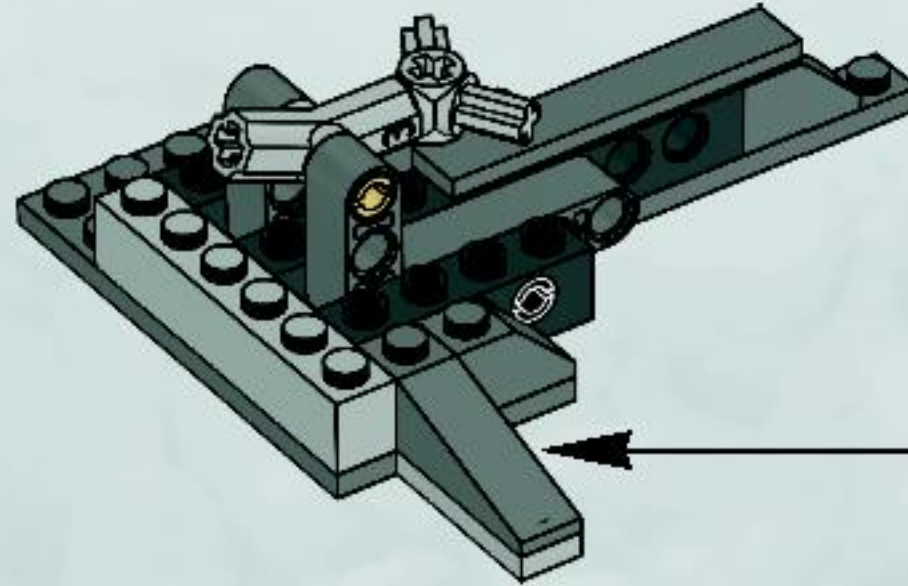

11

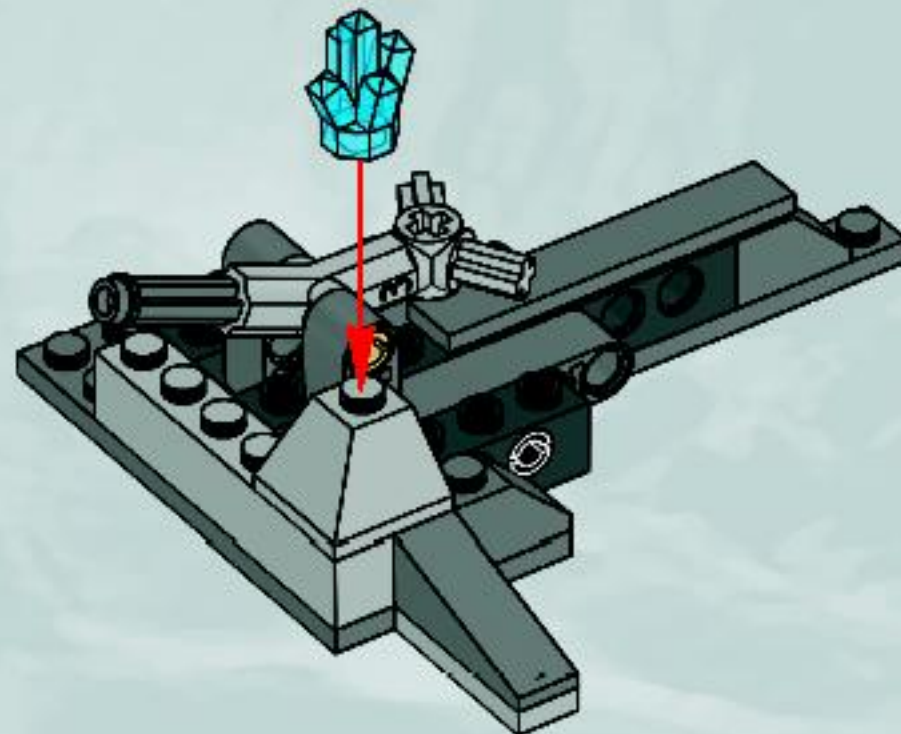

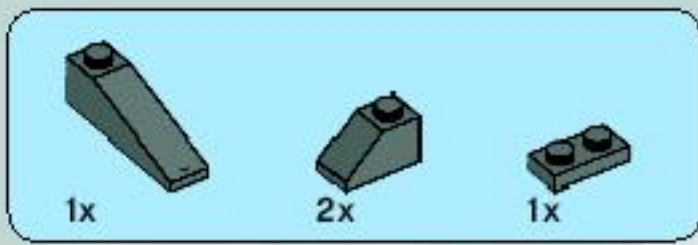

12

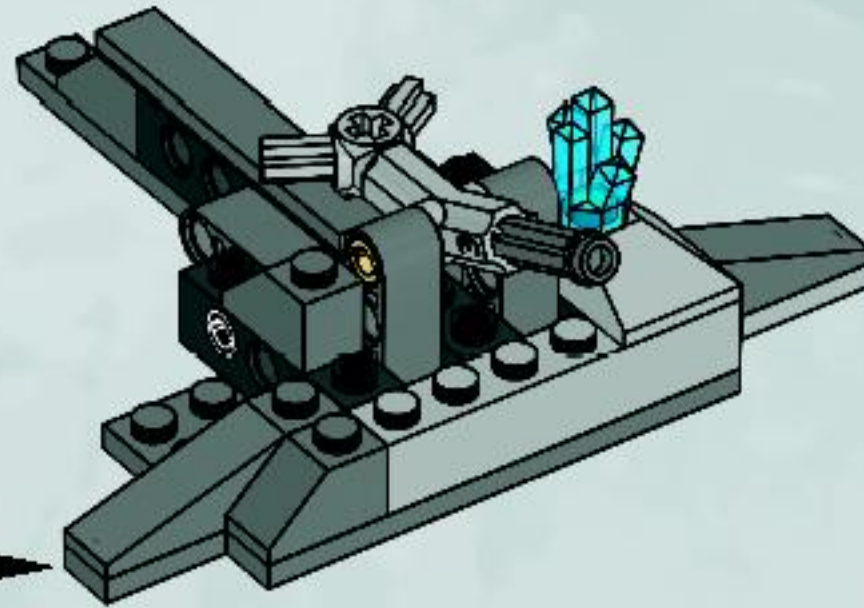
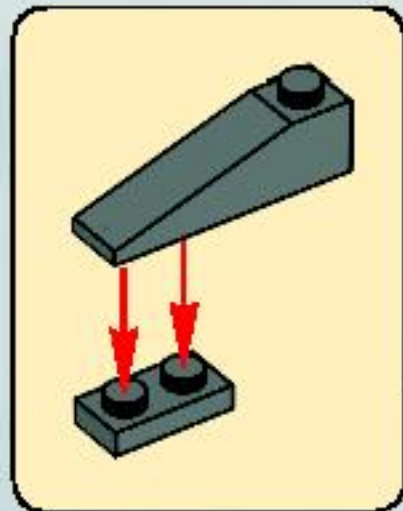

13

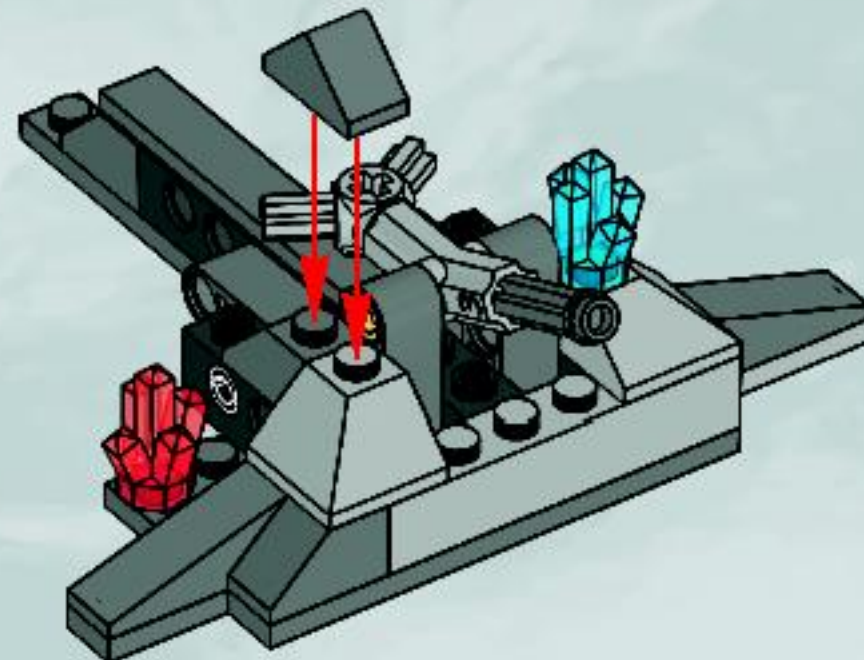

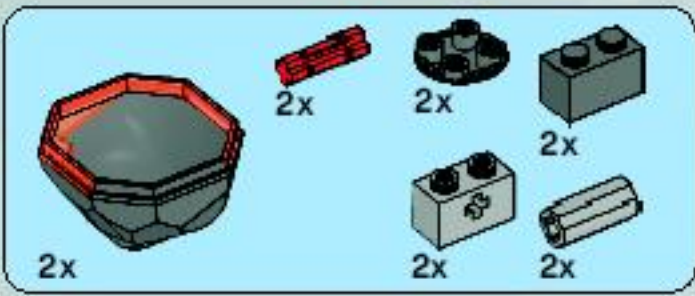

14

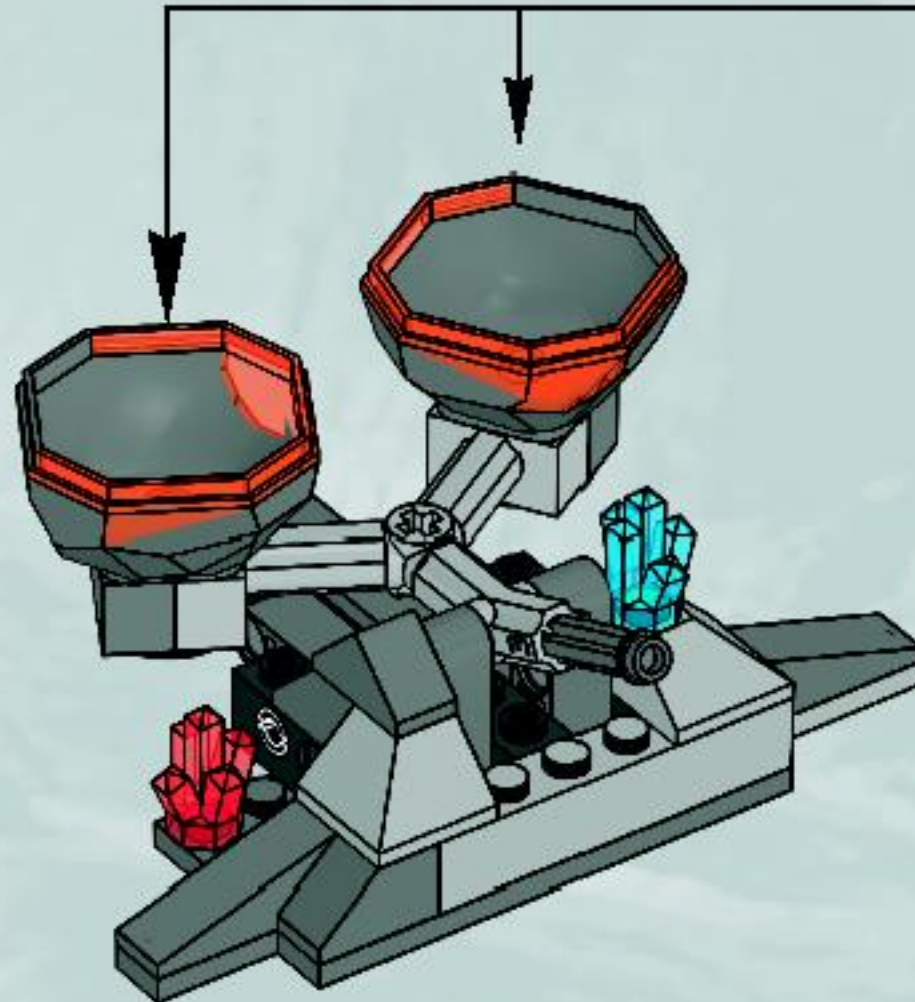
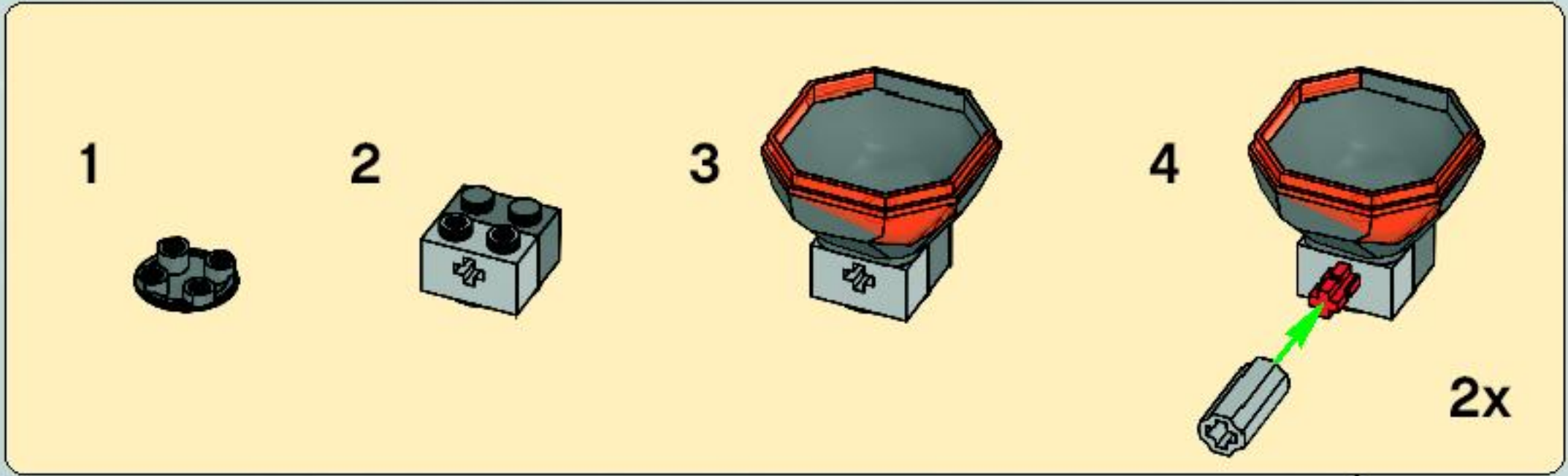

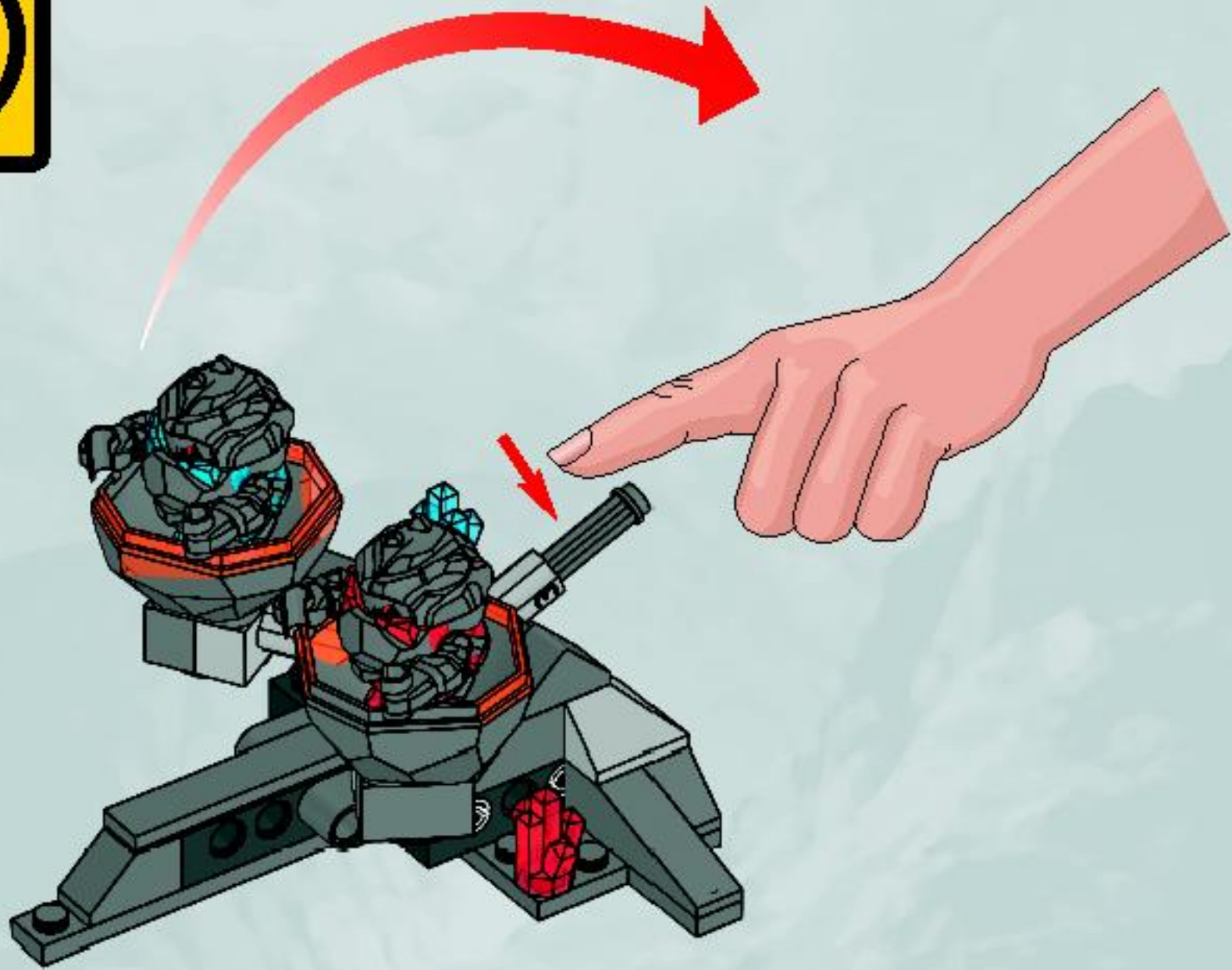

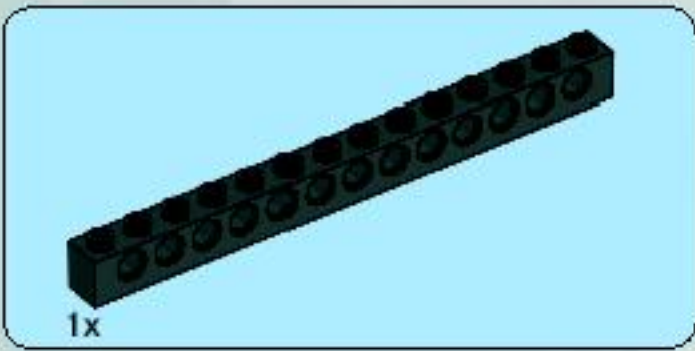
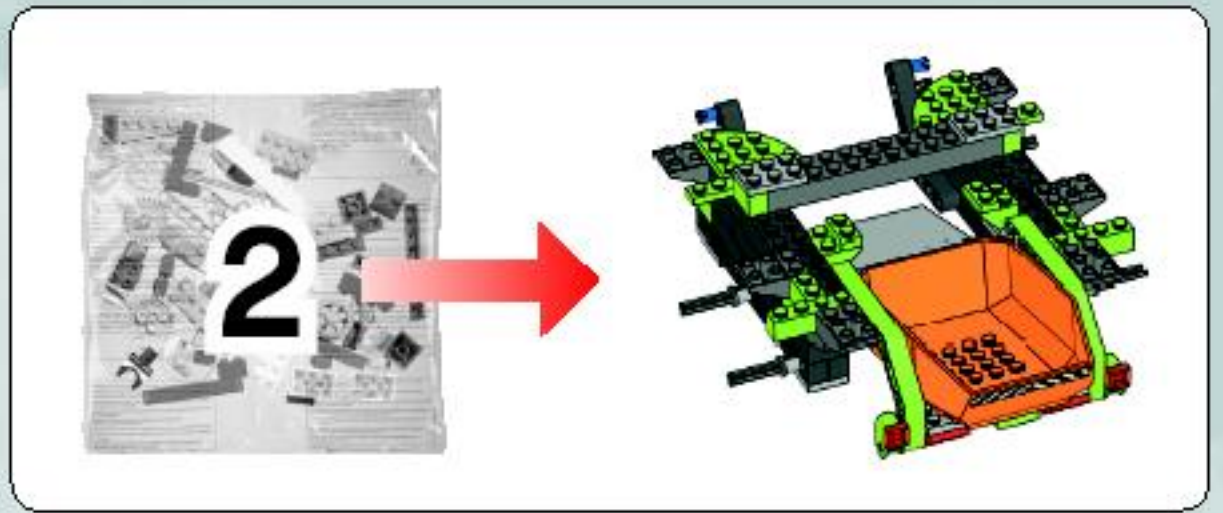
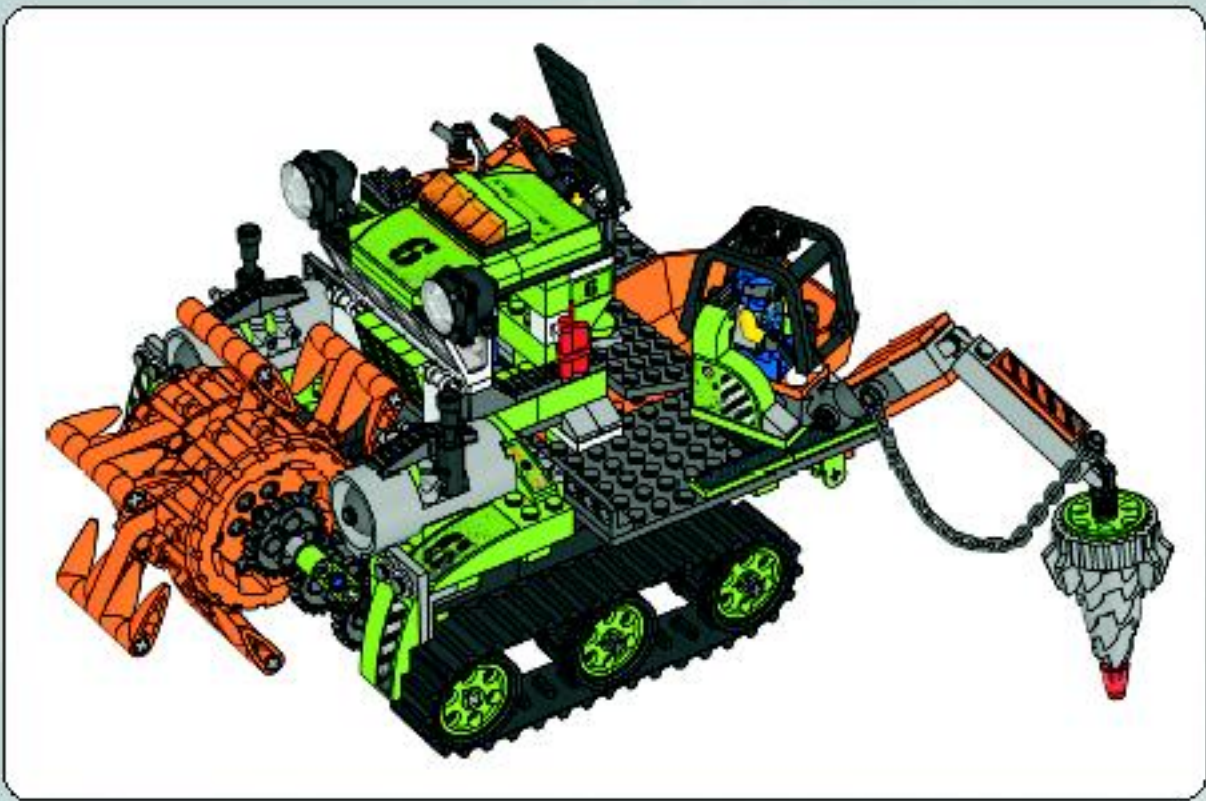

1

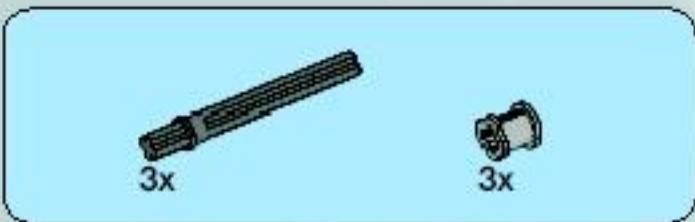

2

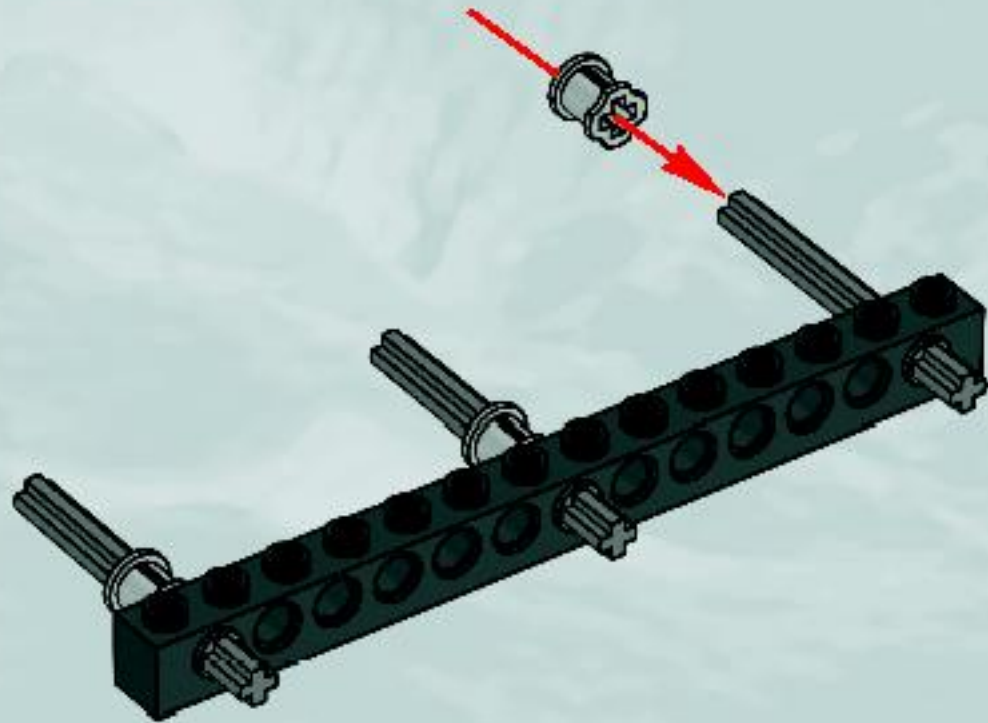

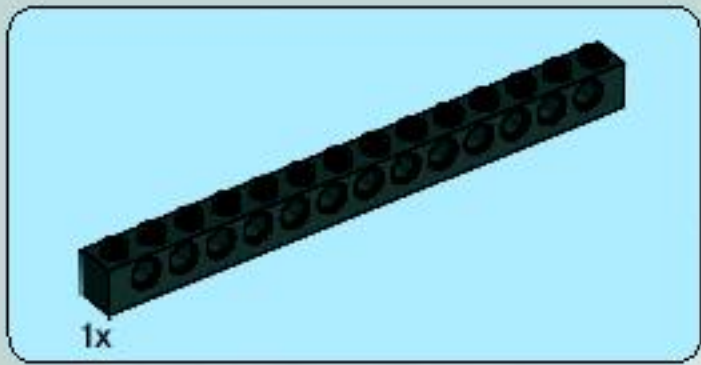

3

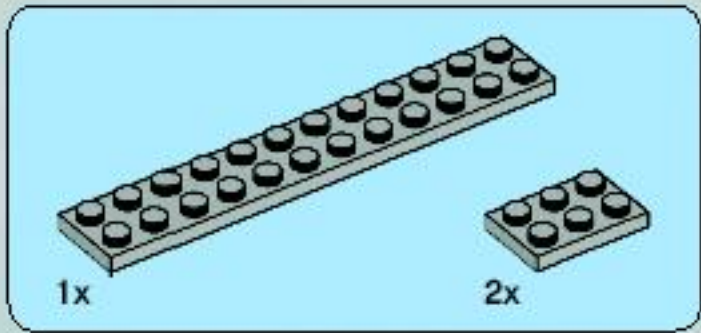
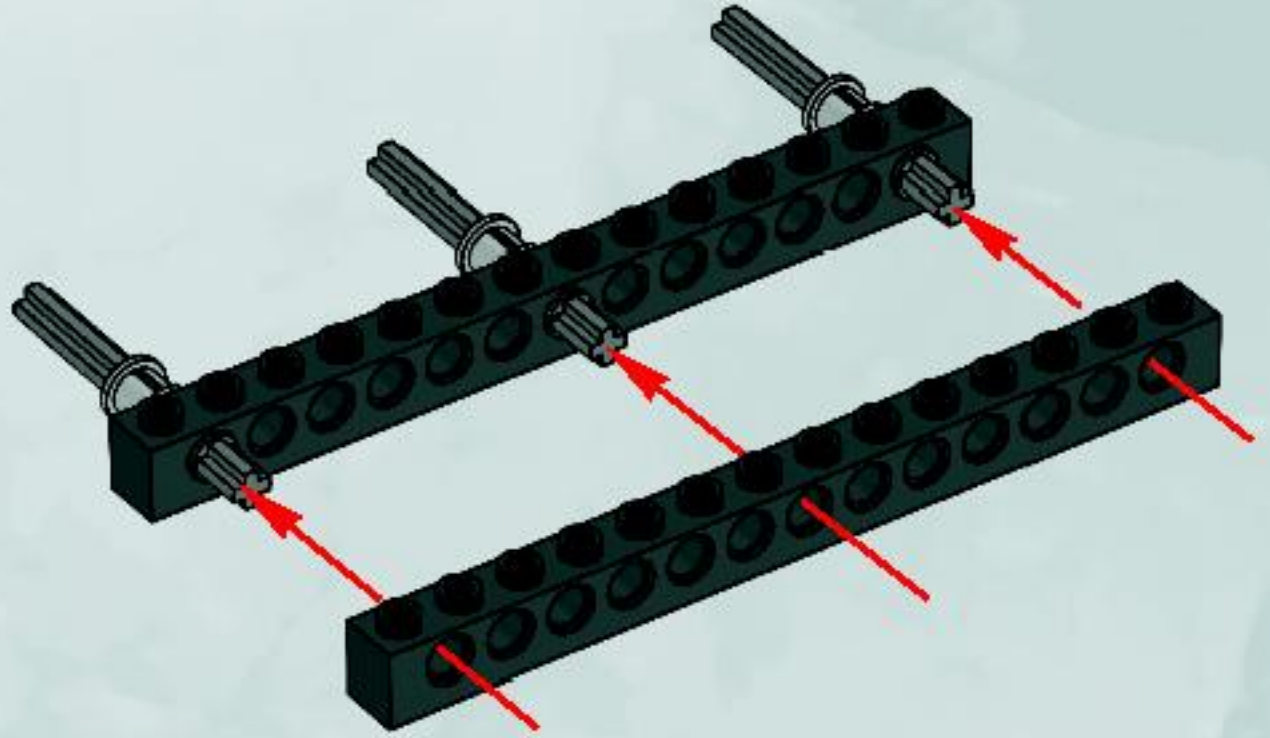

4

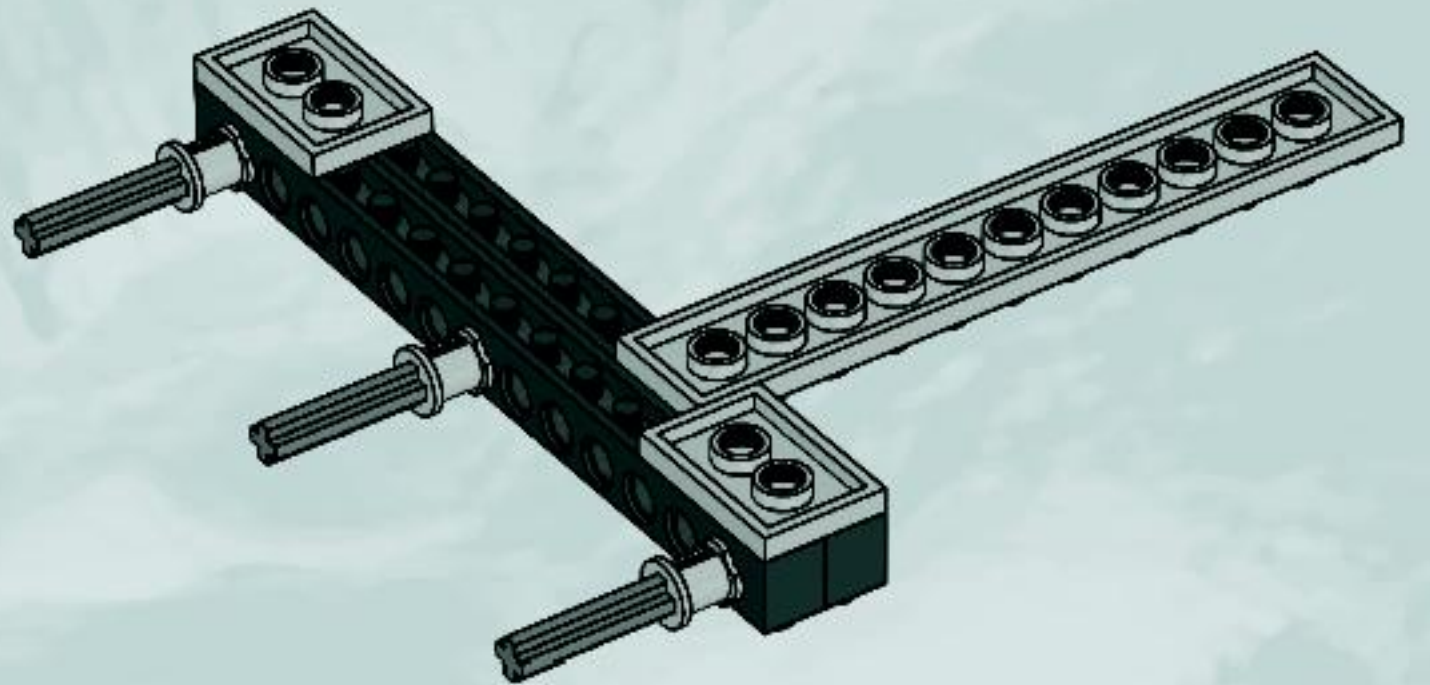

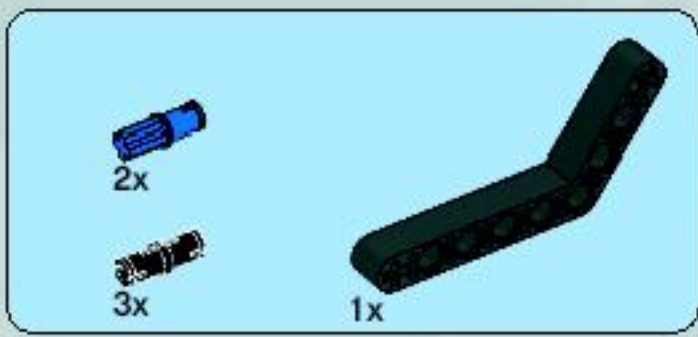

5

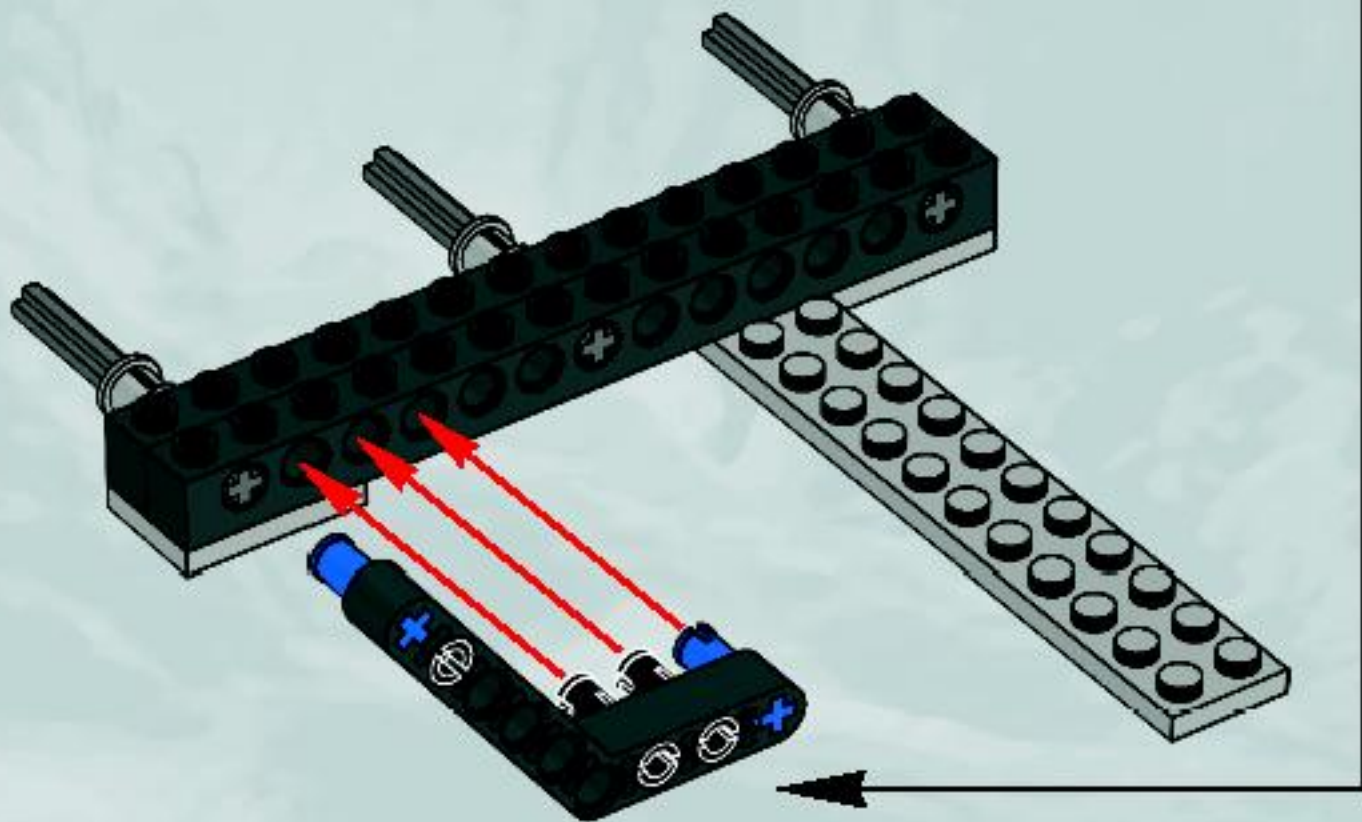
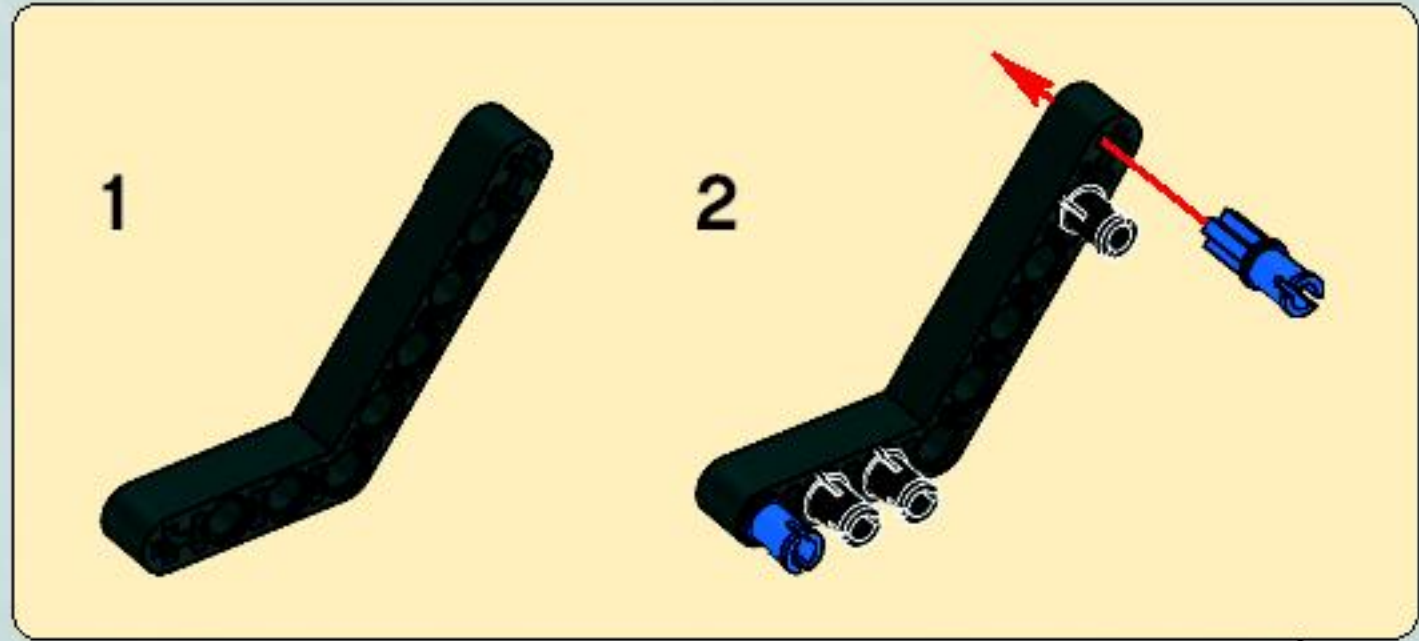



6

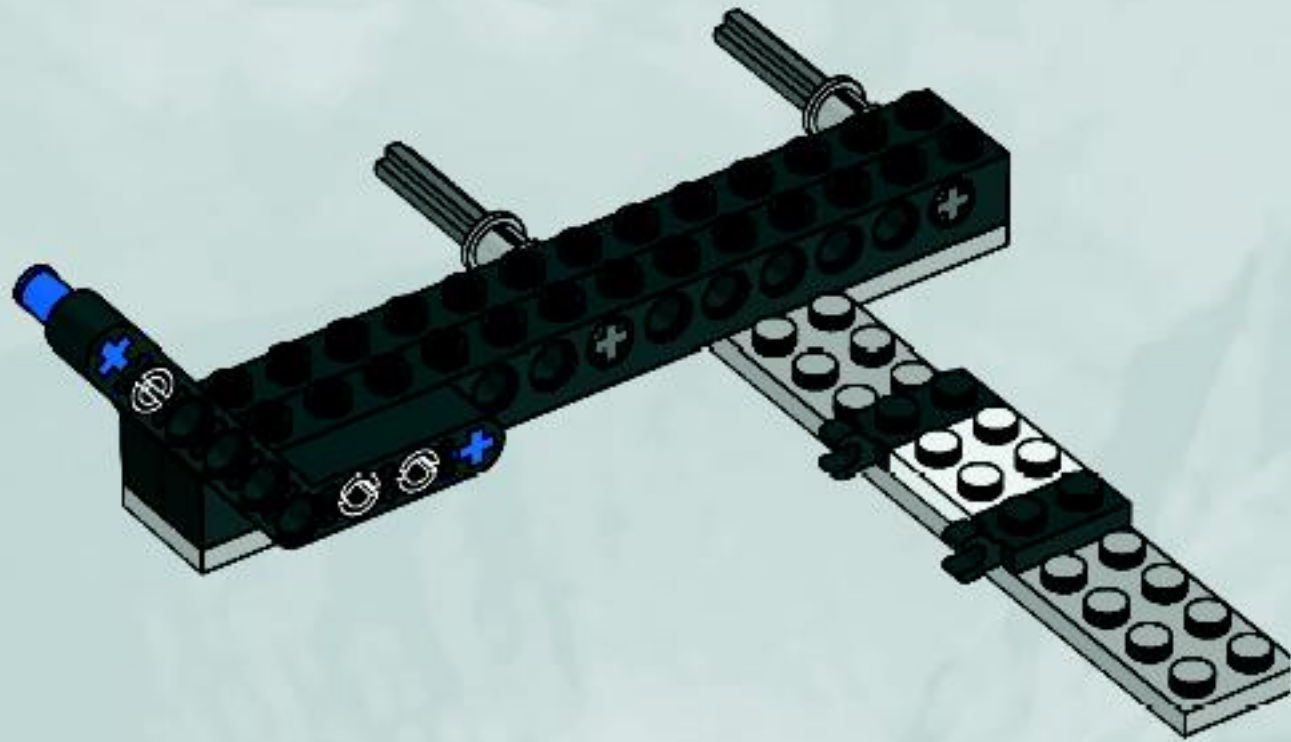

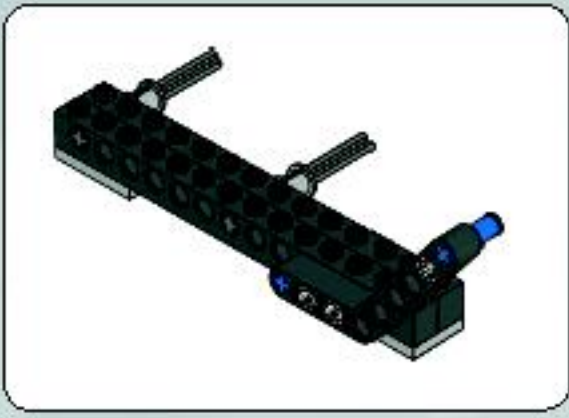

1

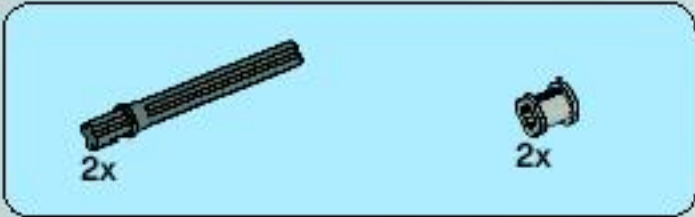

2

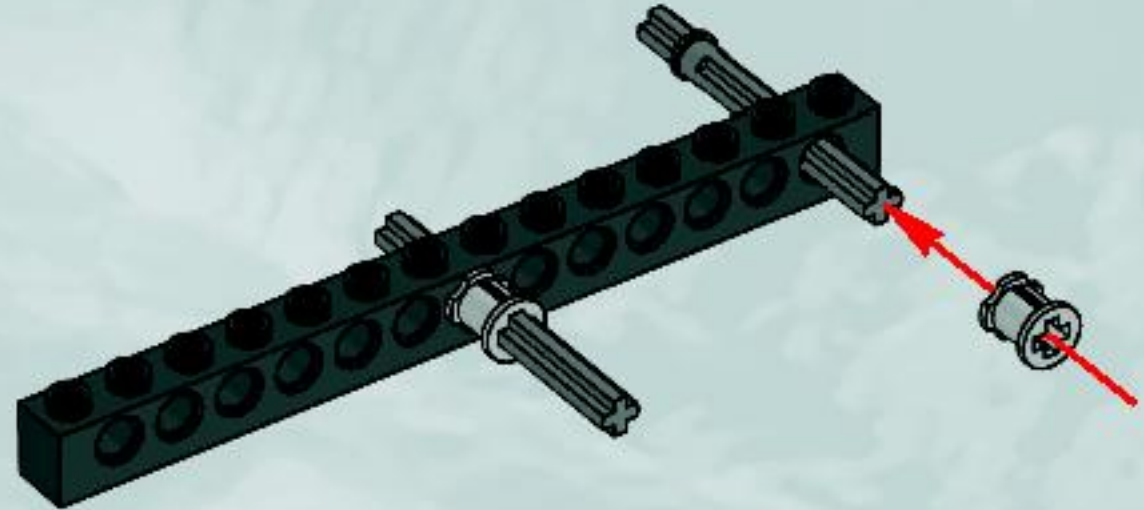

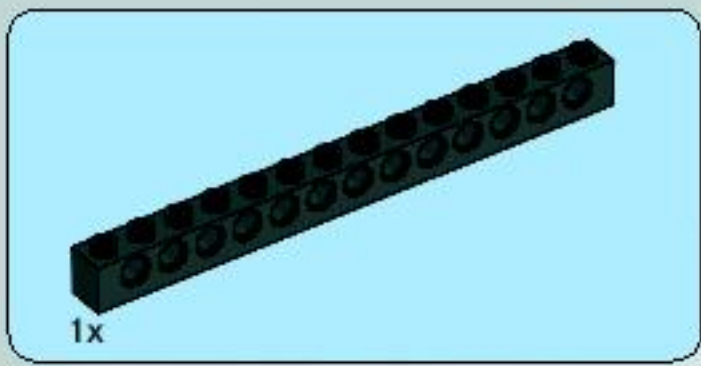

3

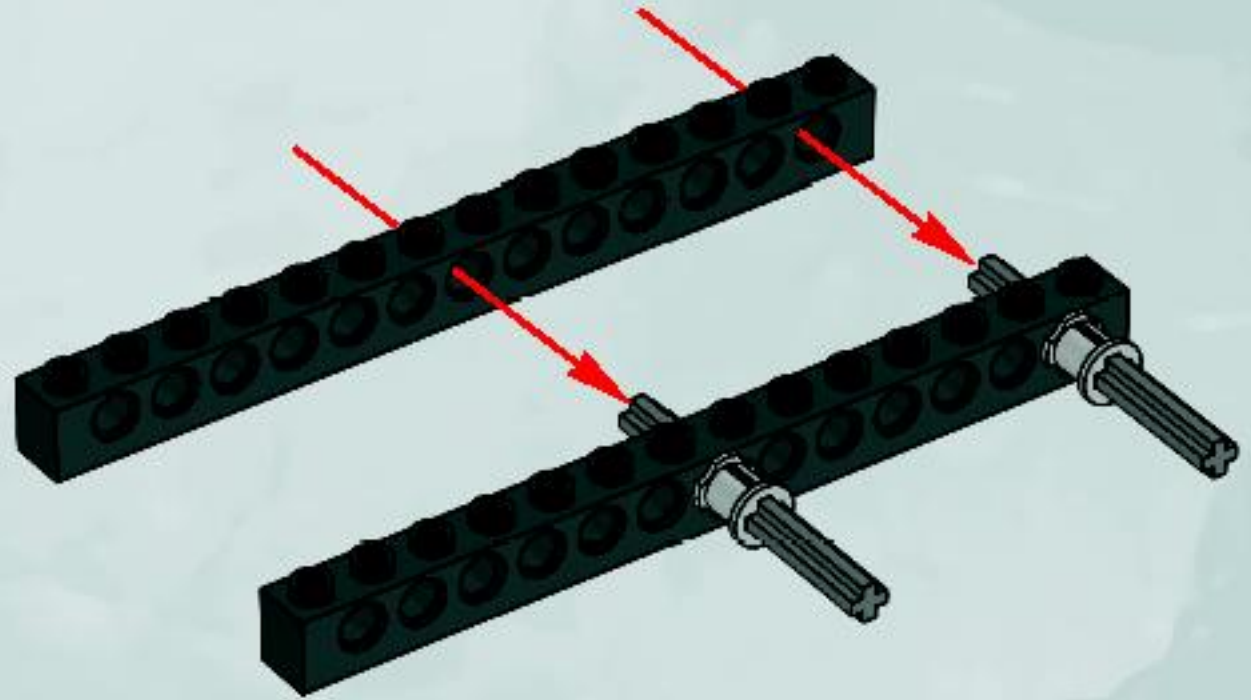

4

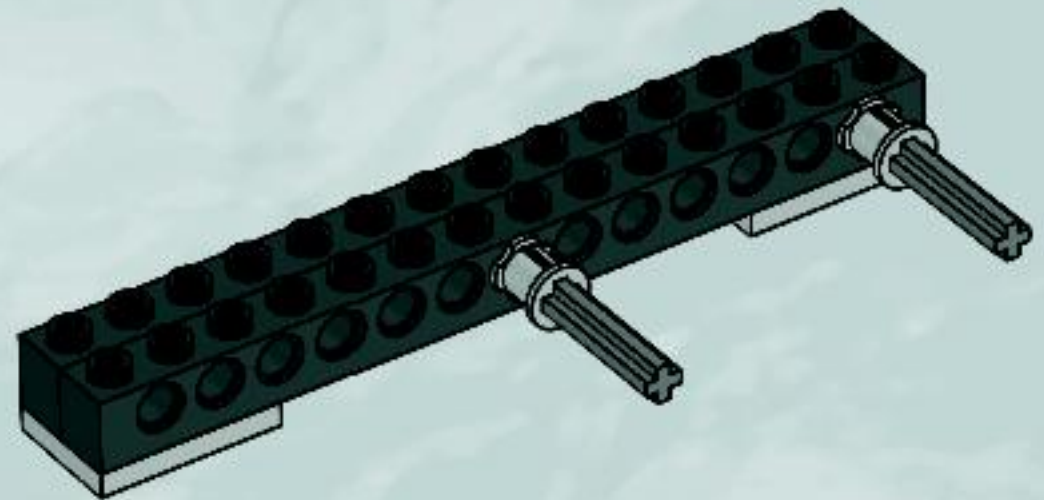

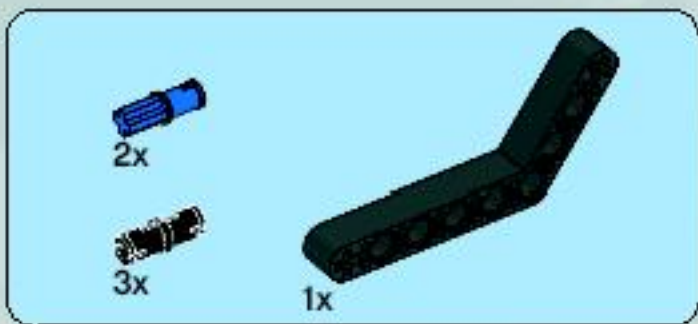

5

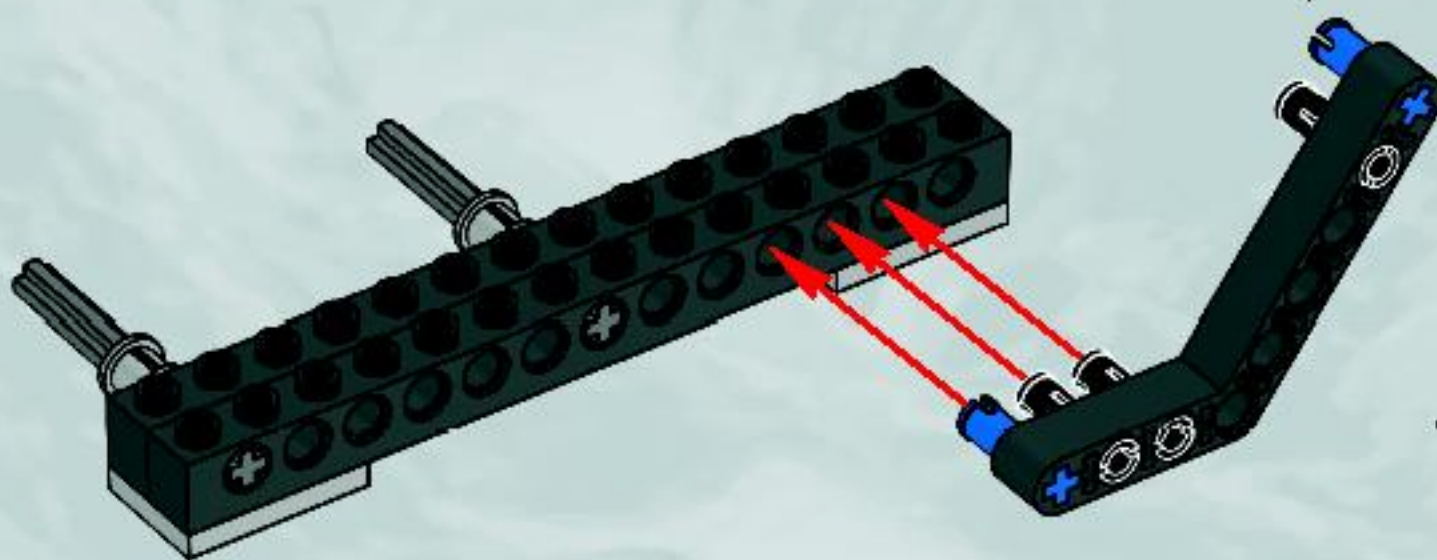
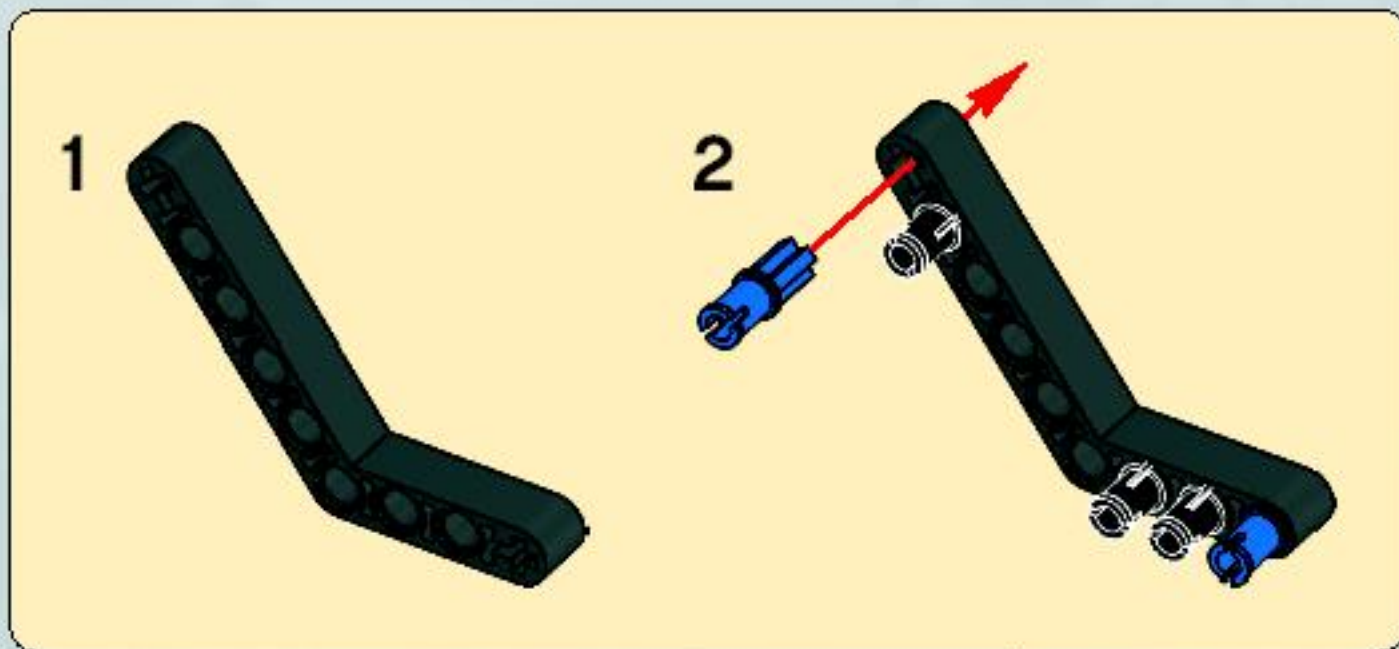

7

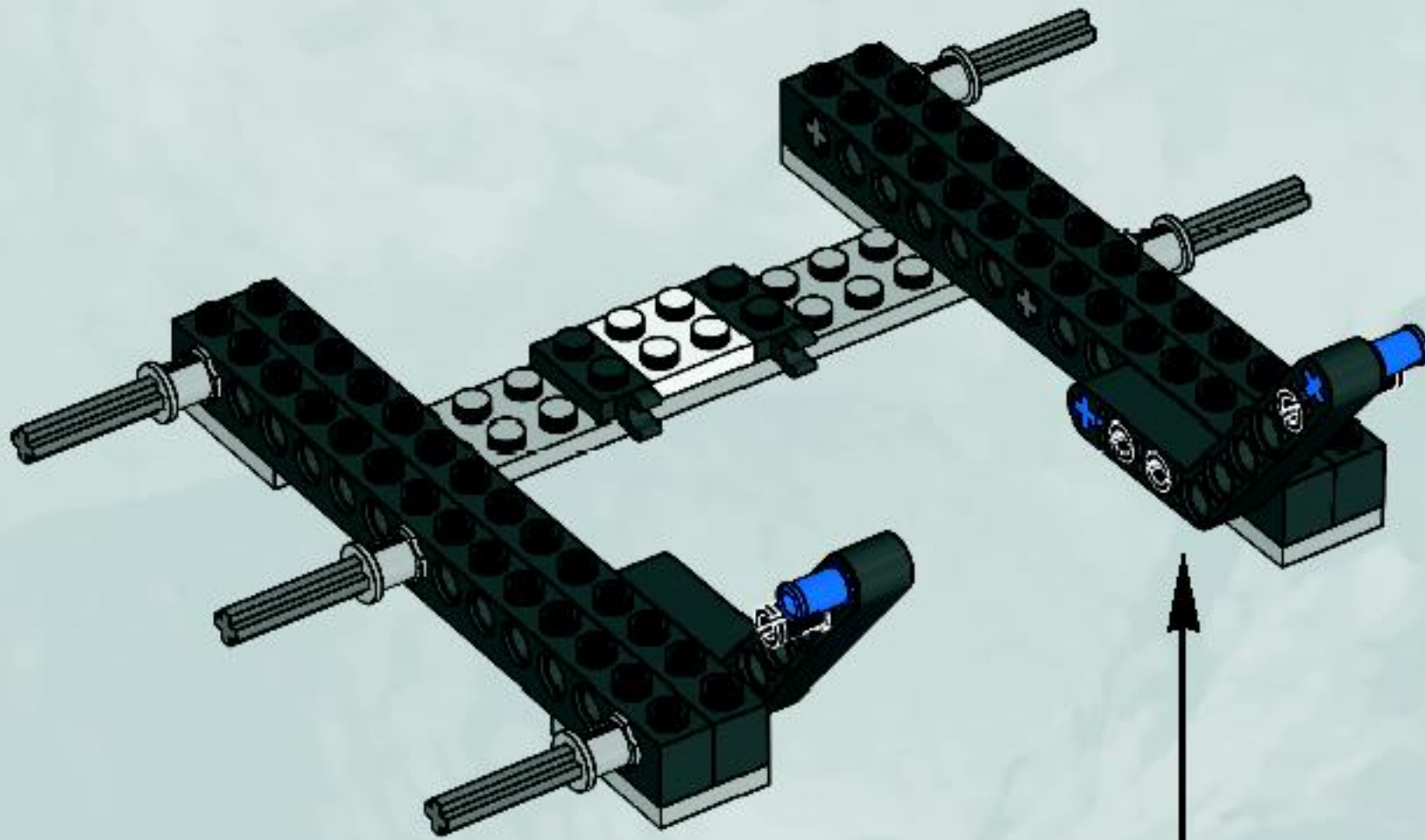

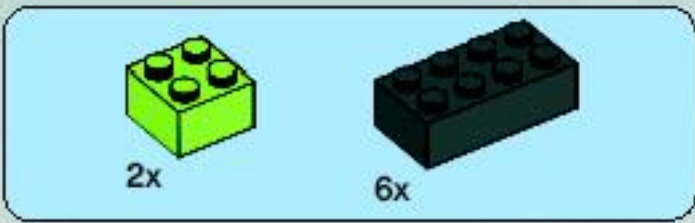

8

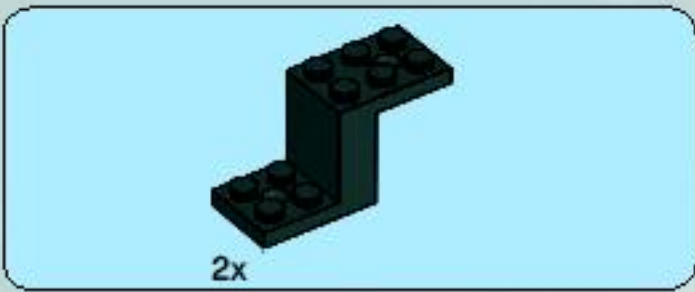
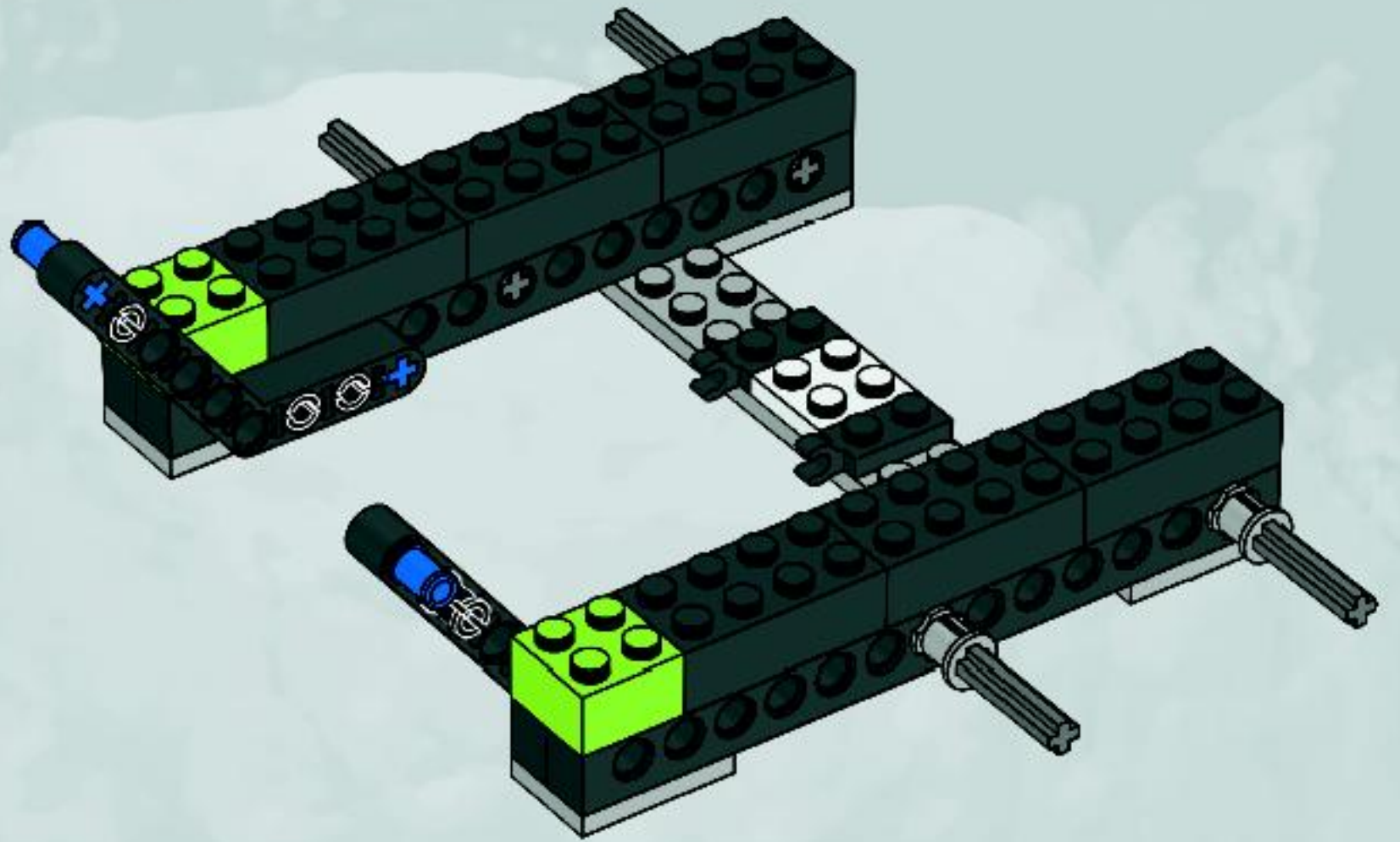

9

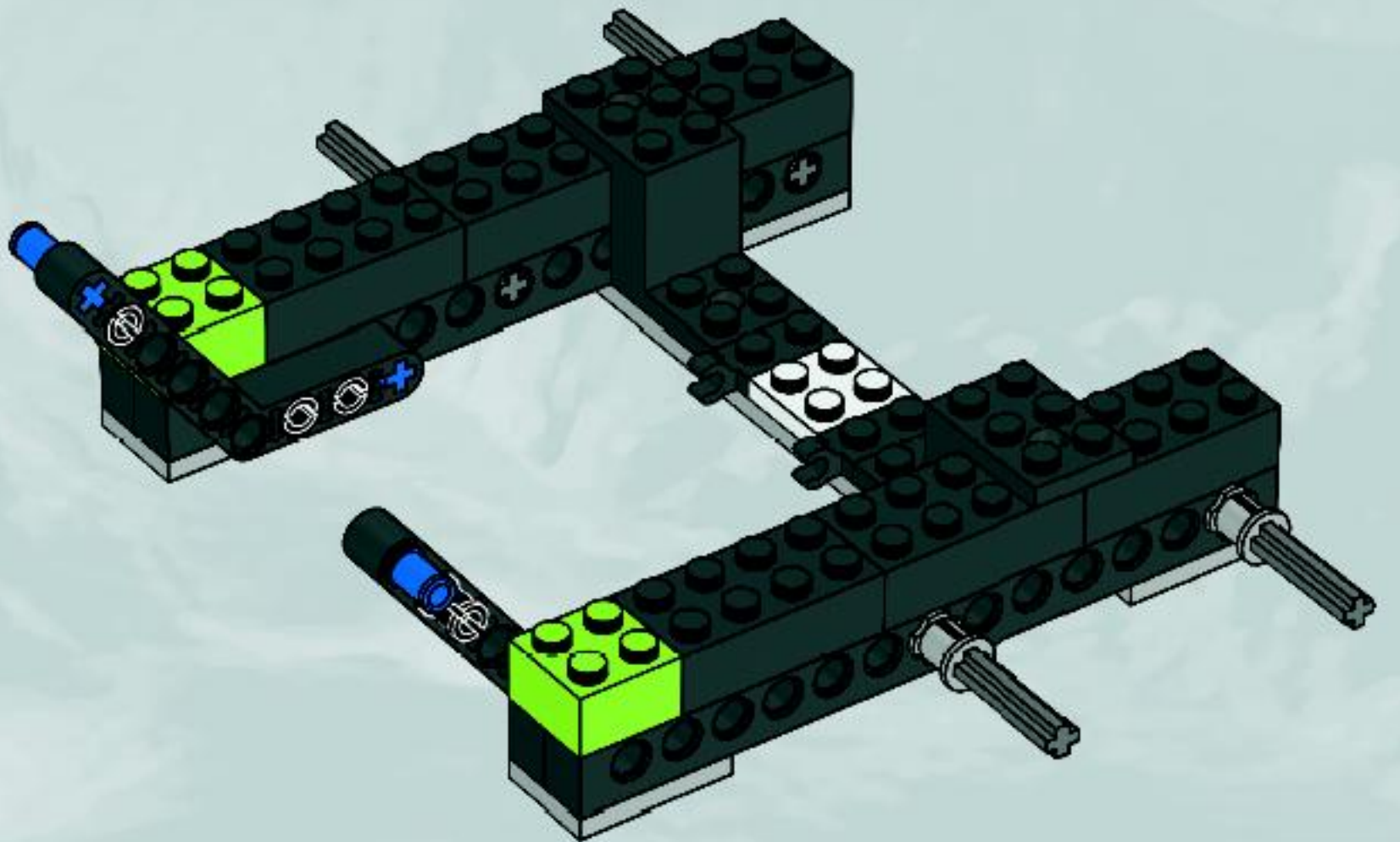

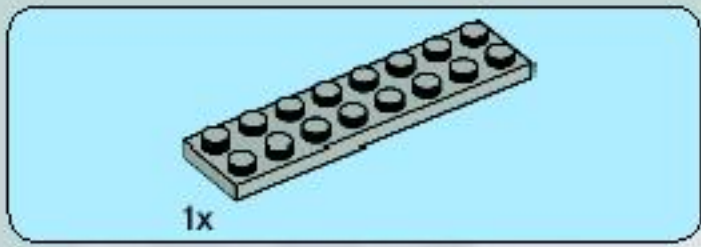

10

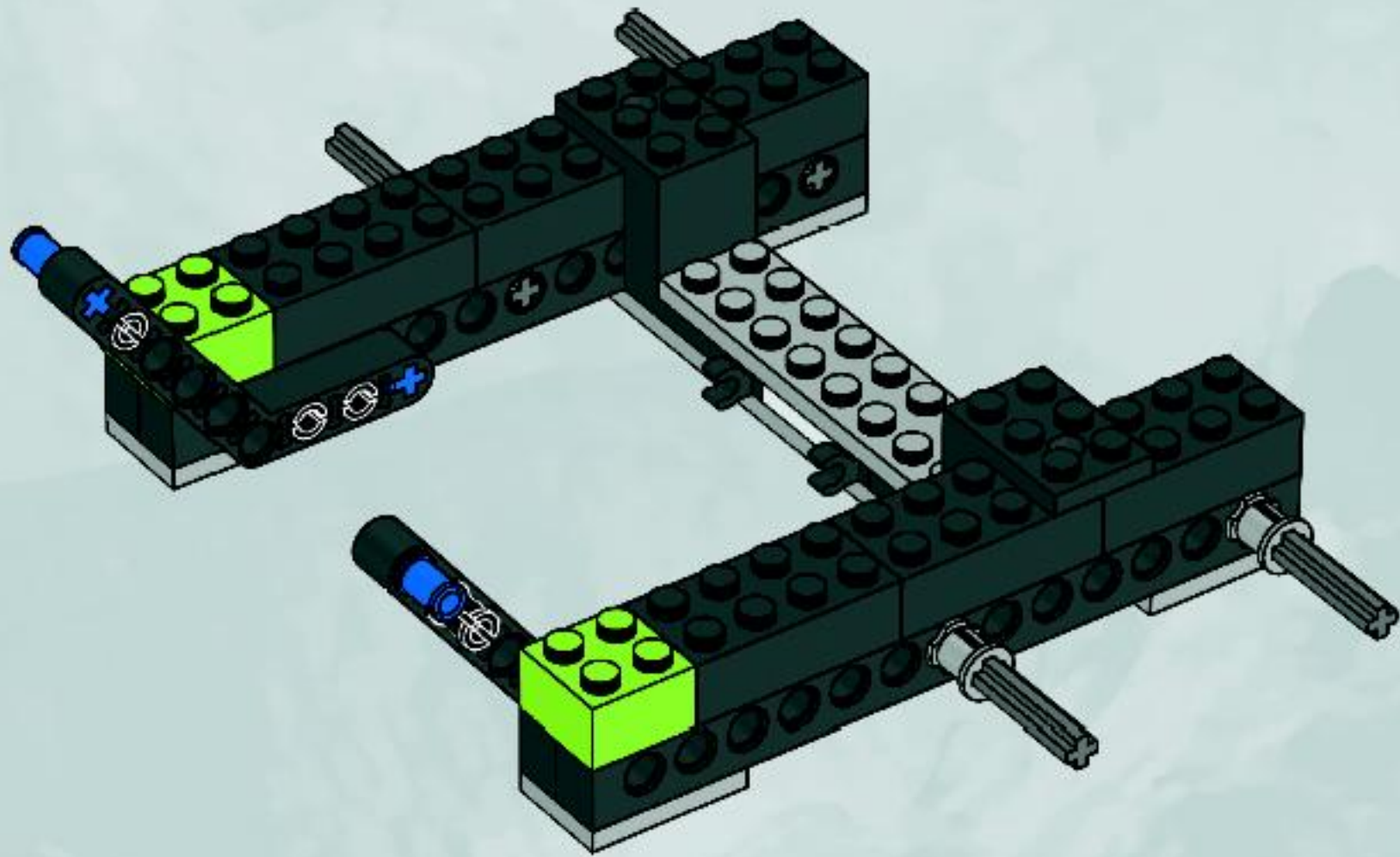



2x

11

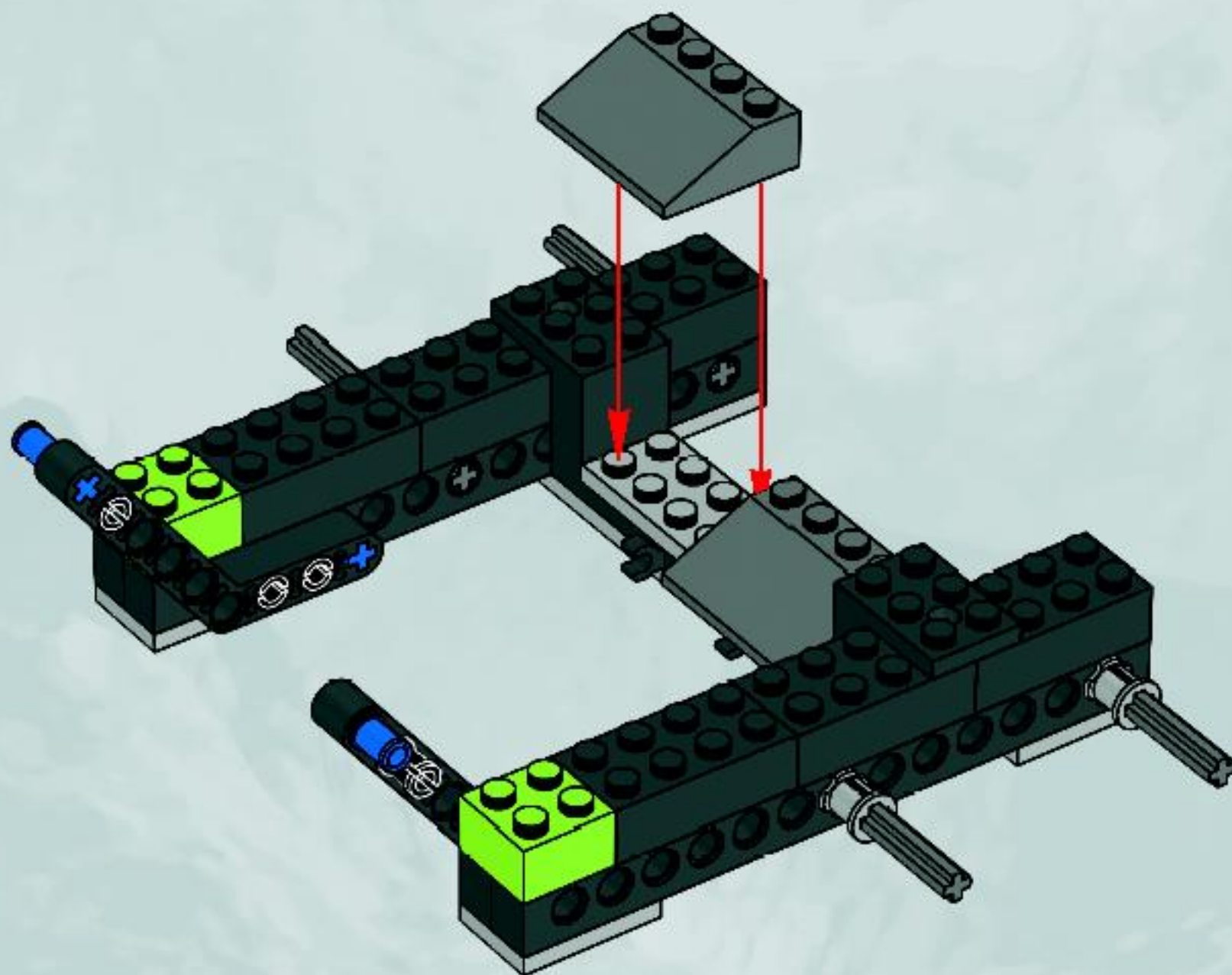

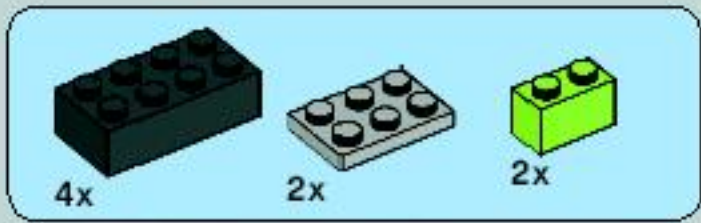

12

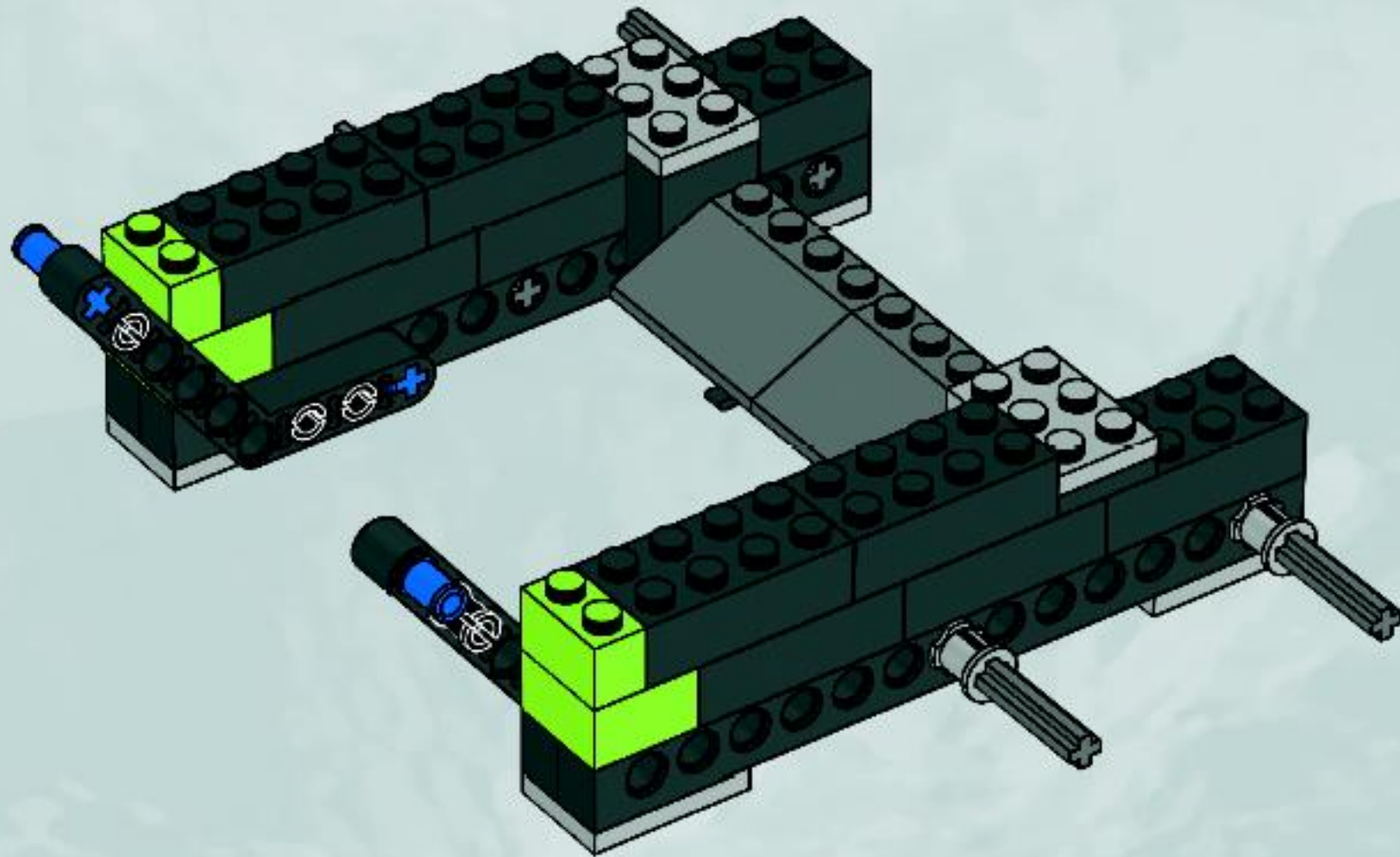



13

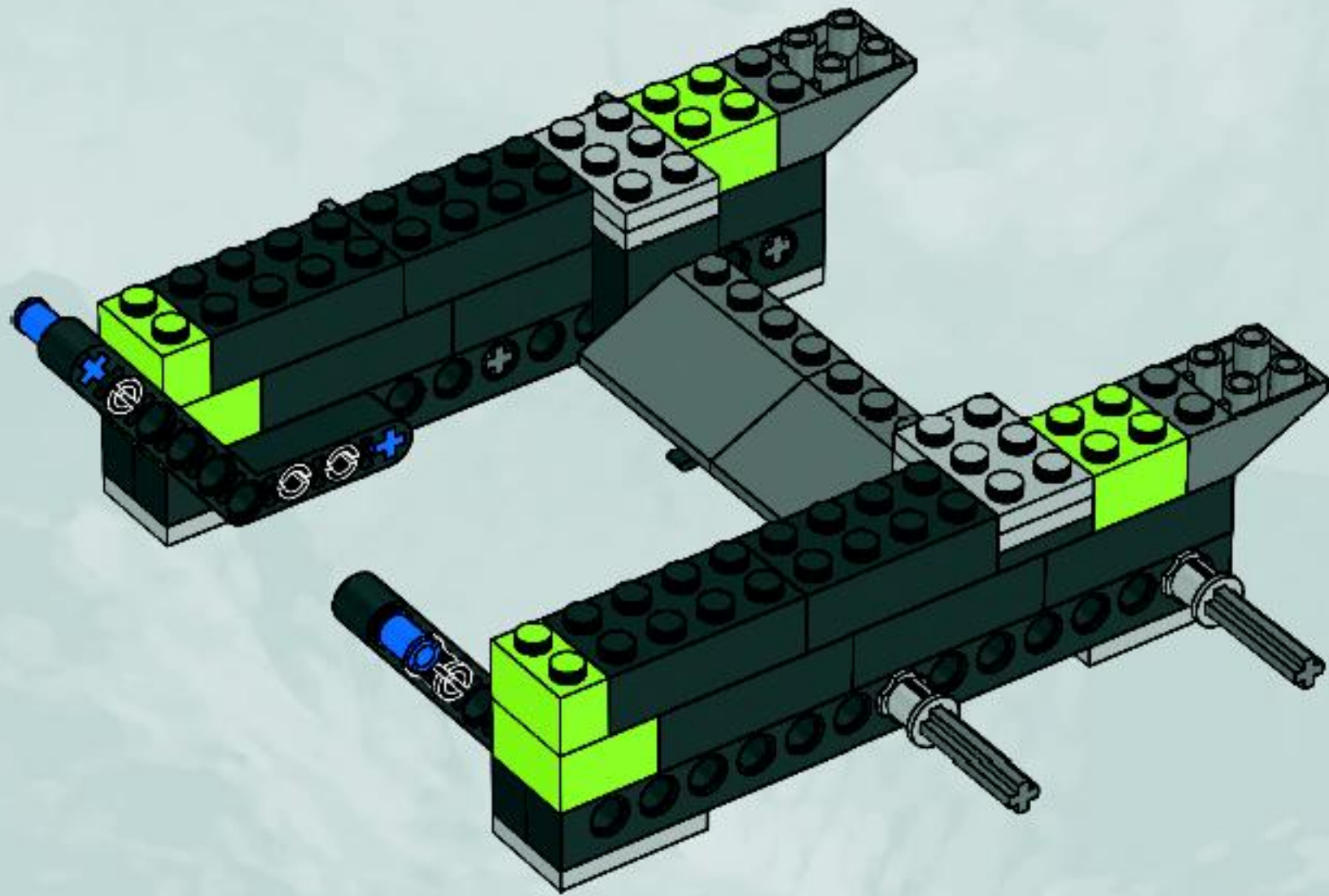

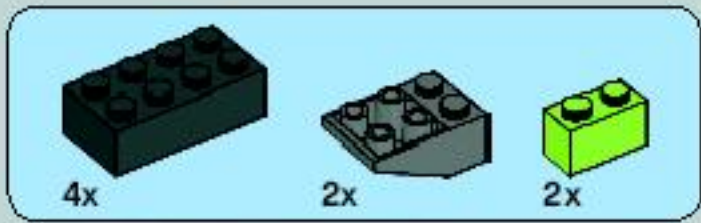

14

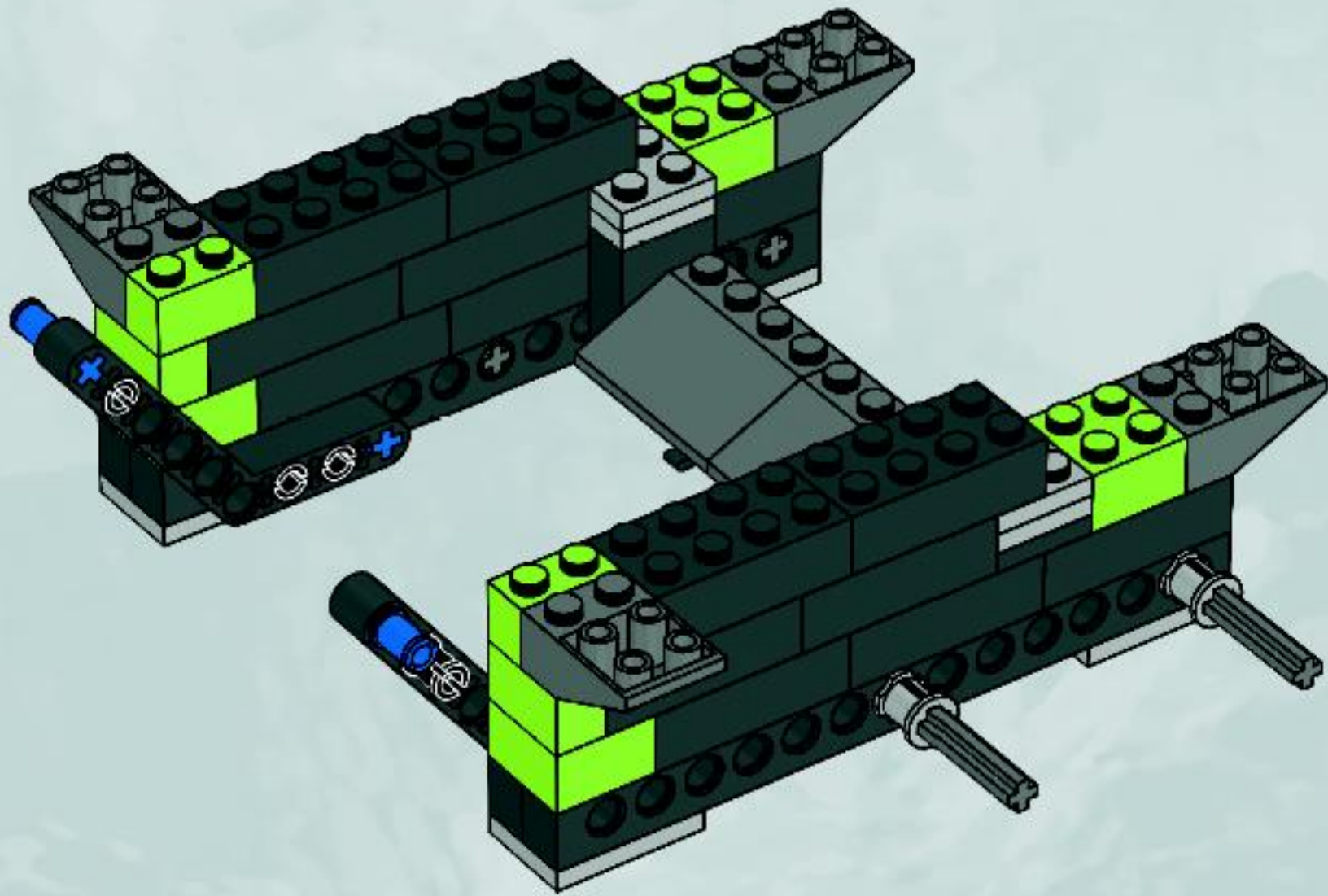

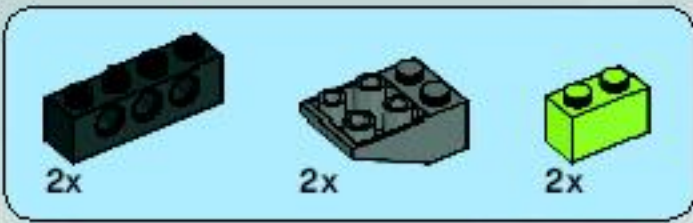

15

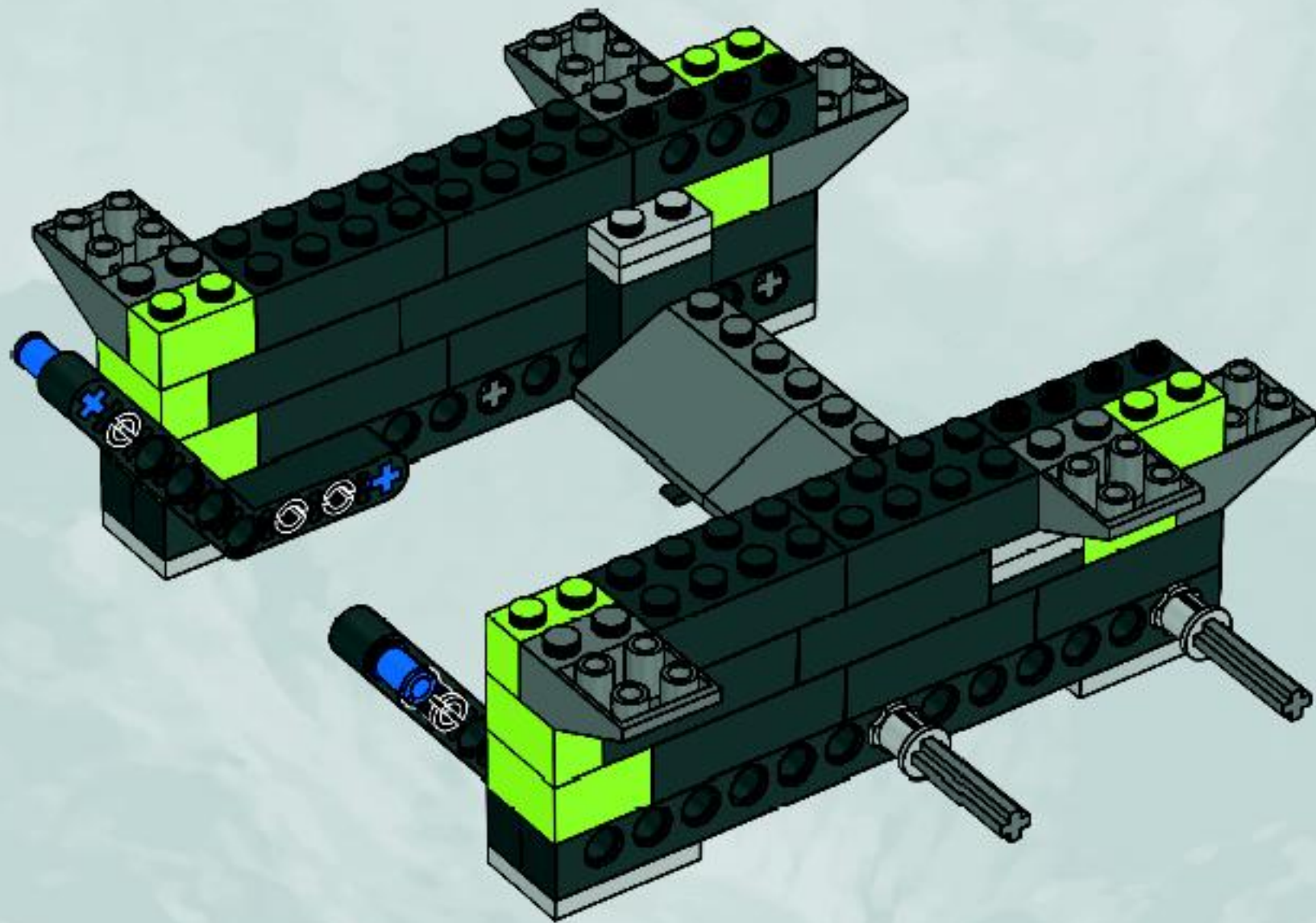

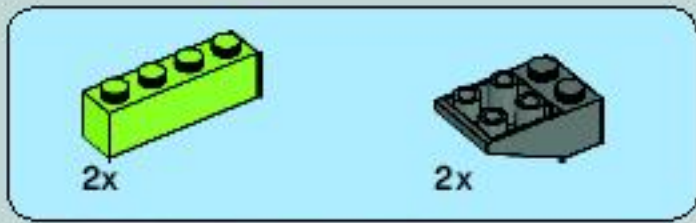

16

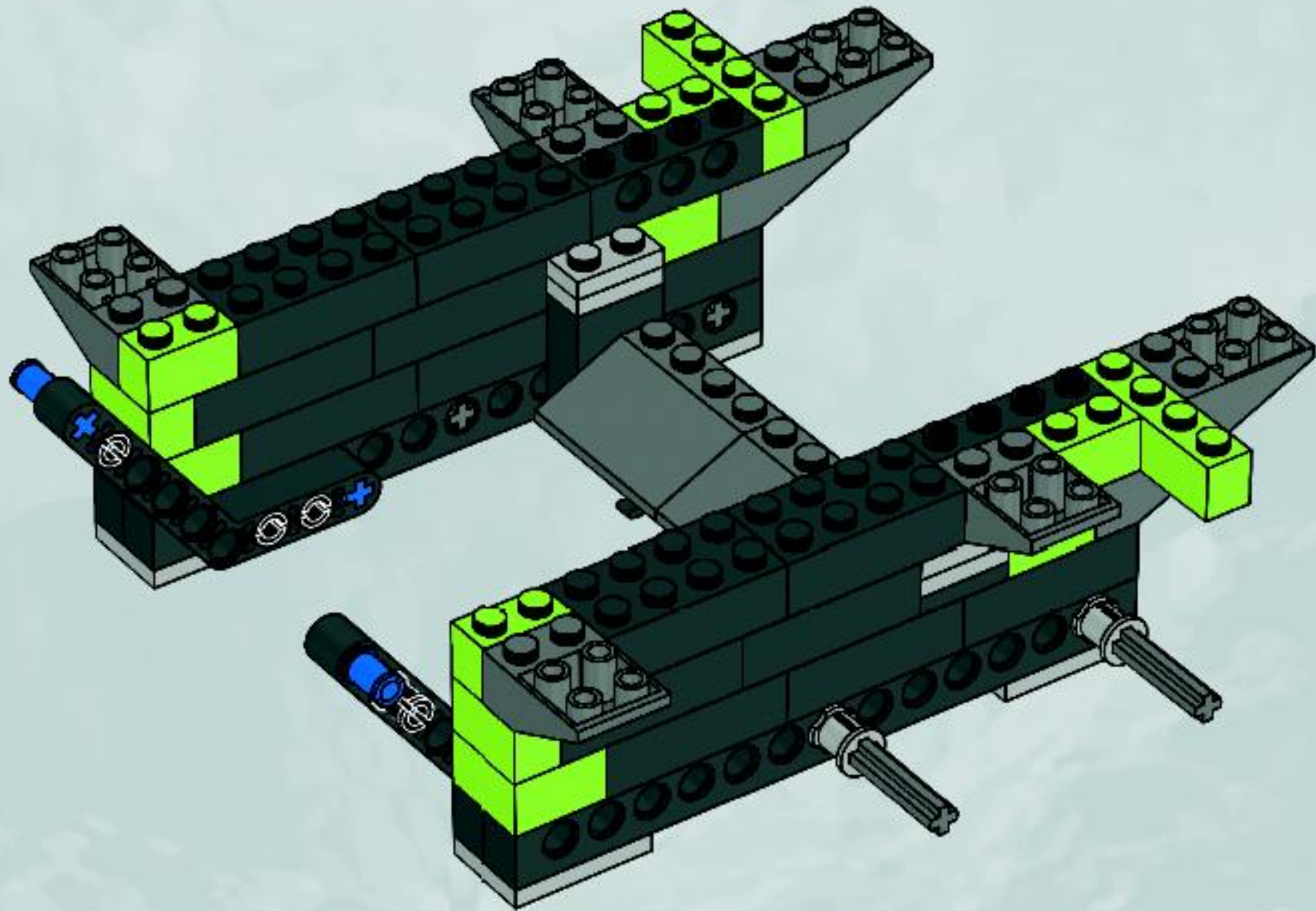

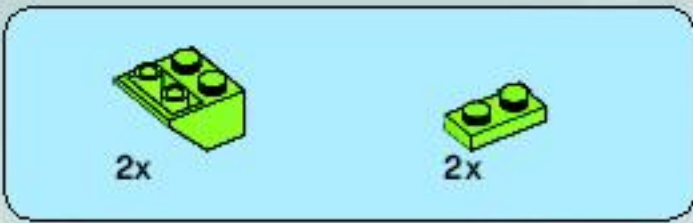

17

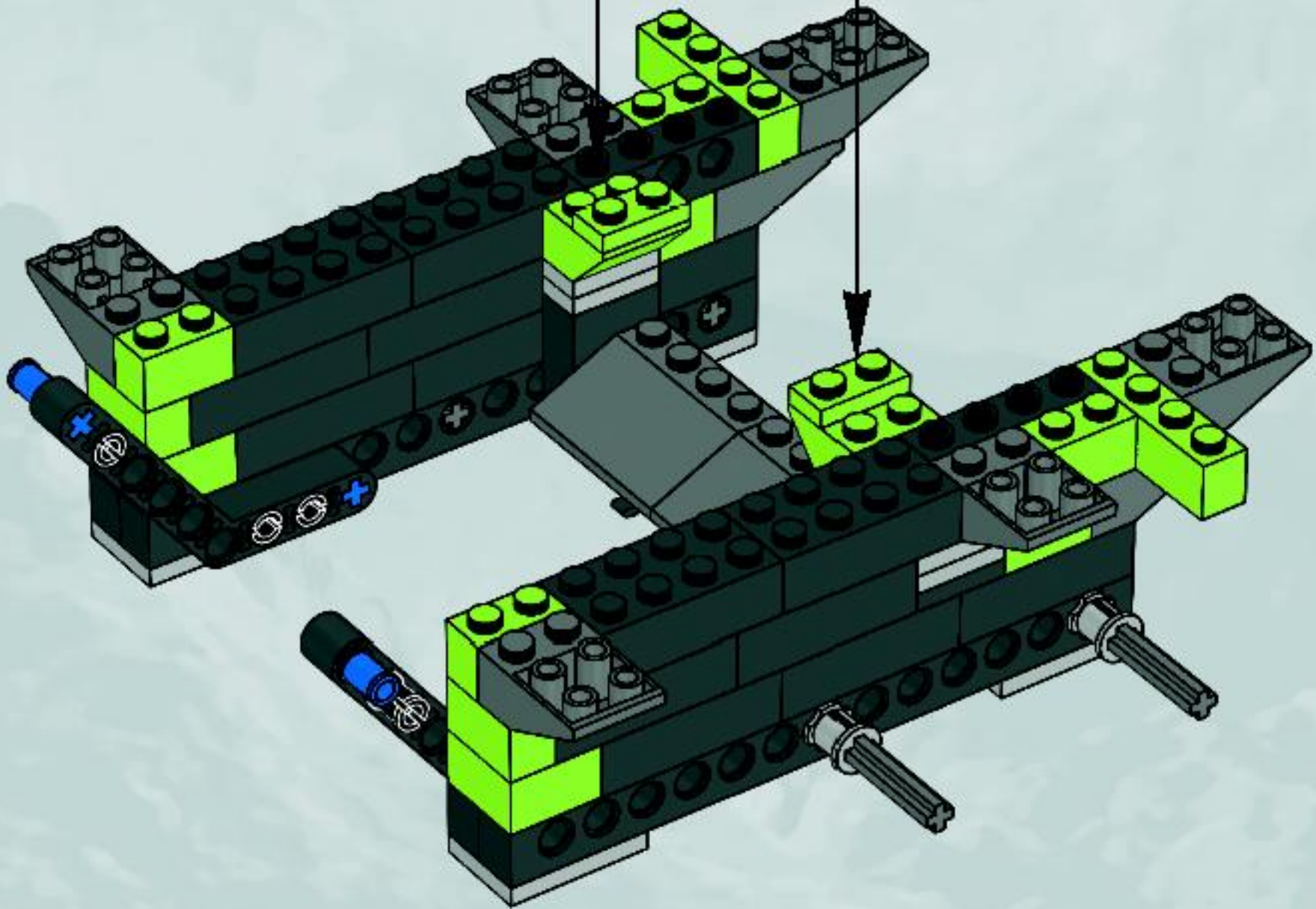
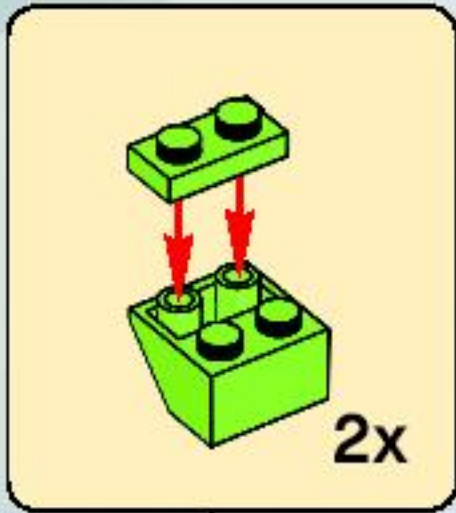

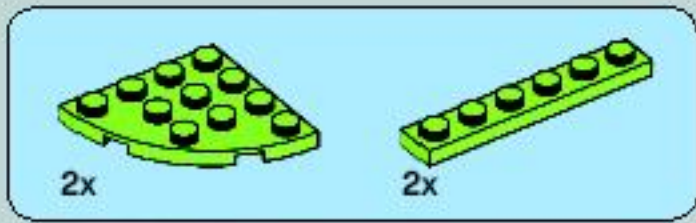

18

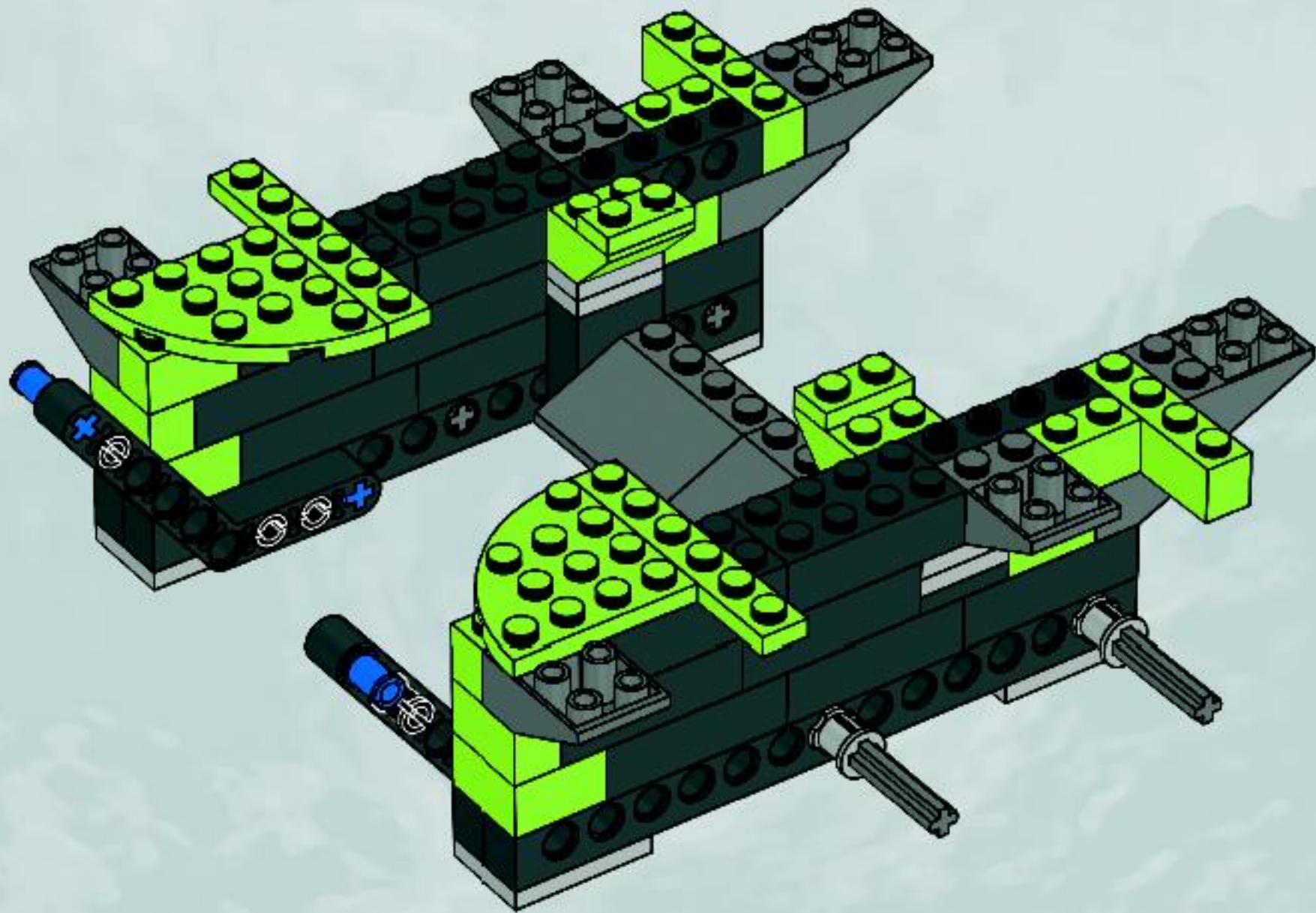

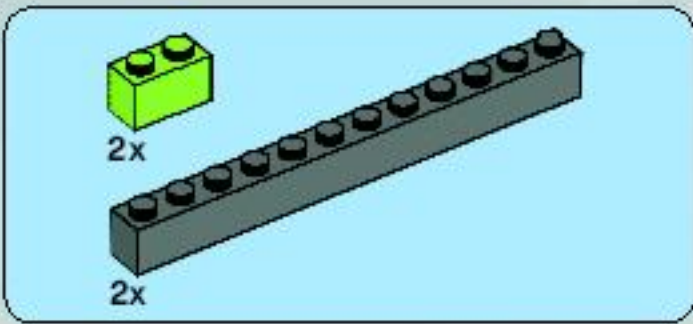

19





2x

20

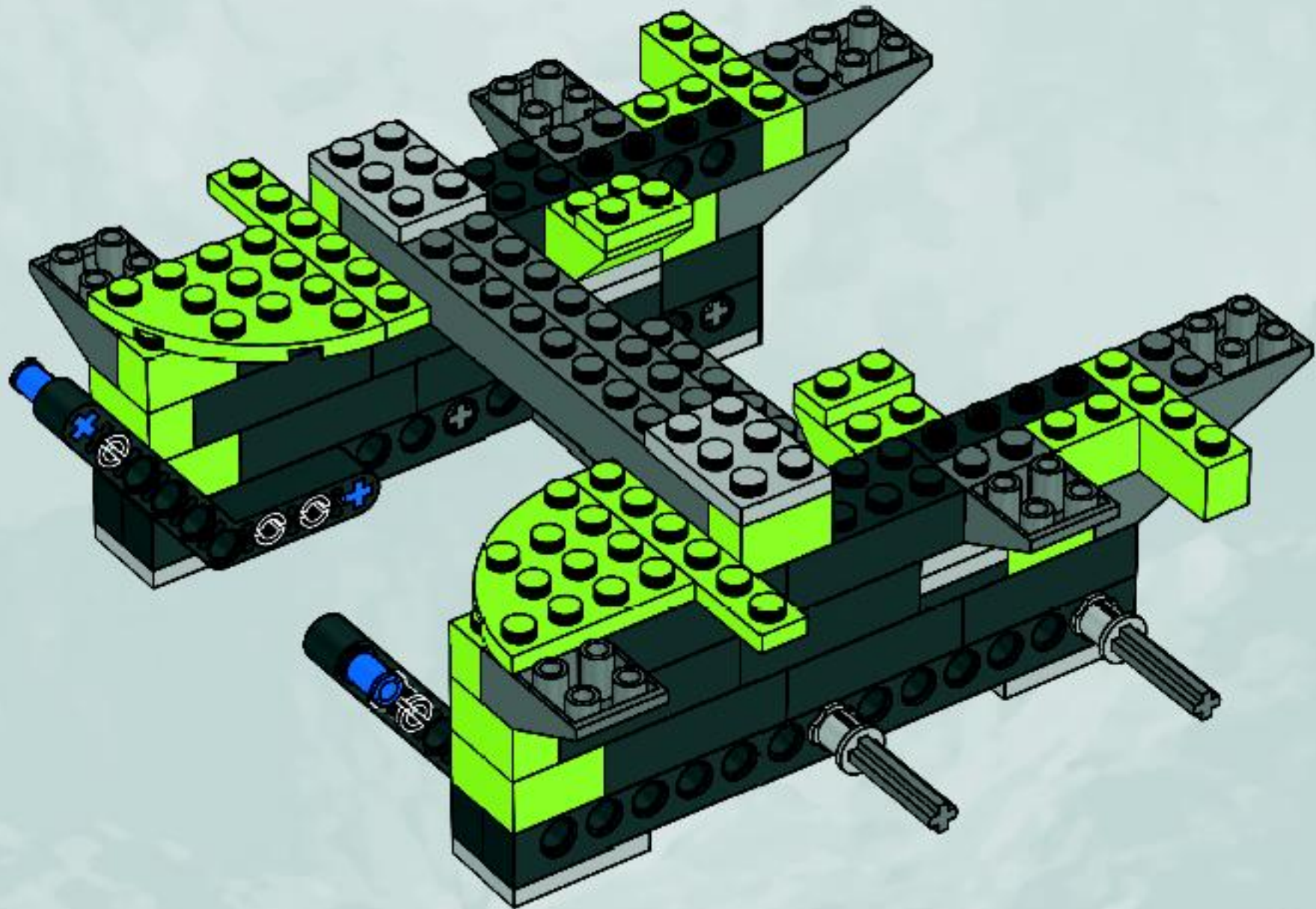

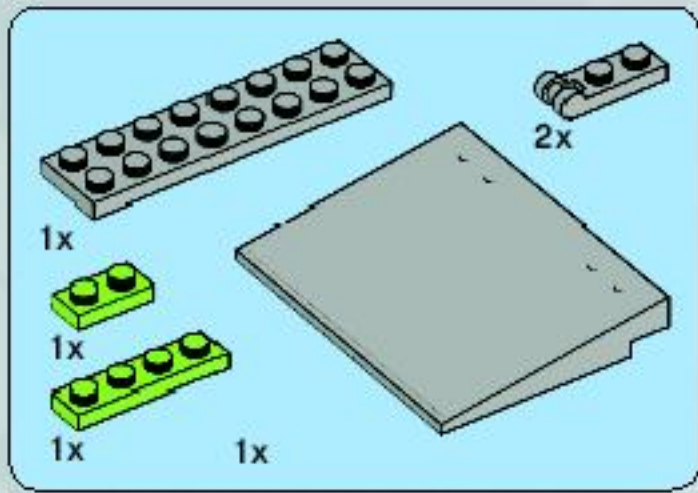

21

1



2

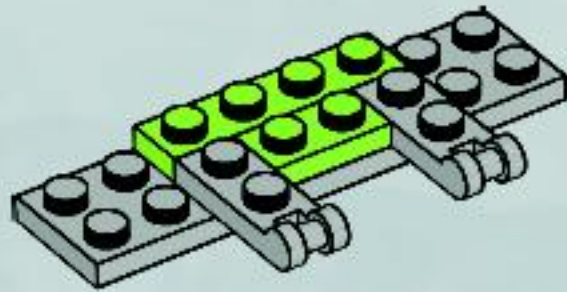

3

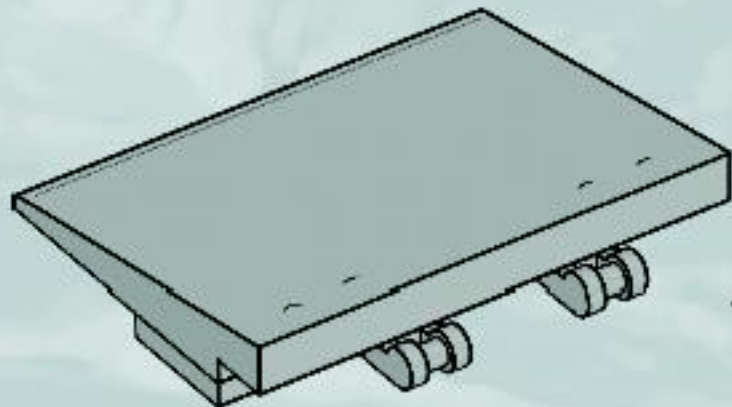

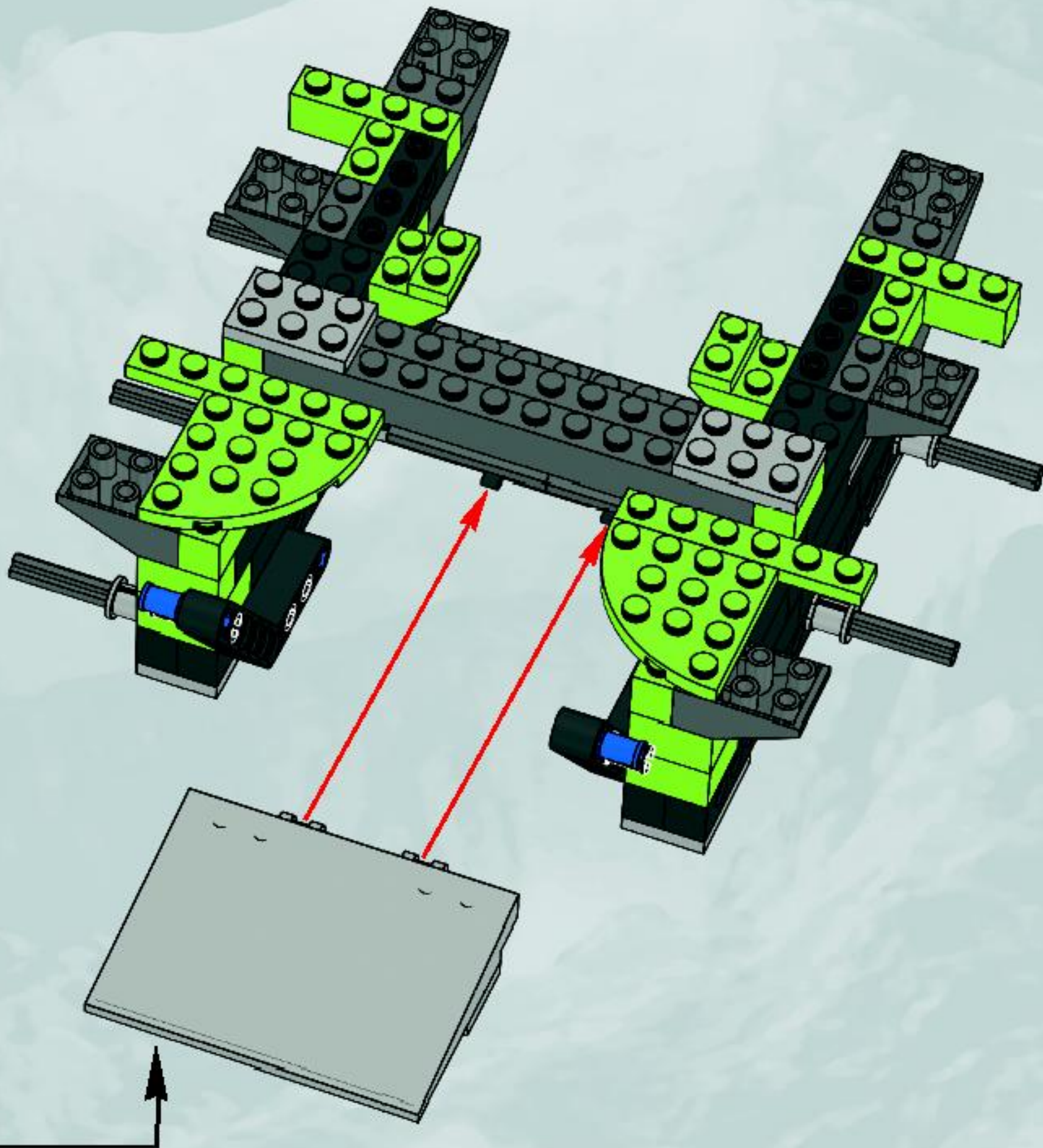

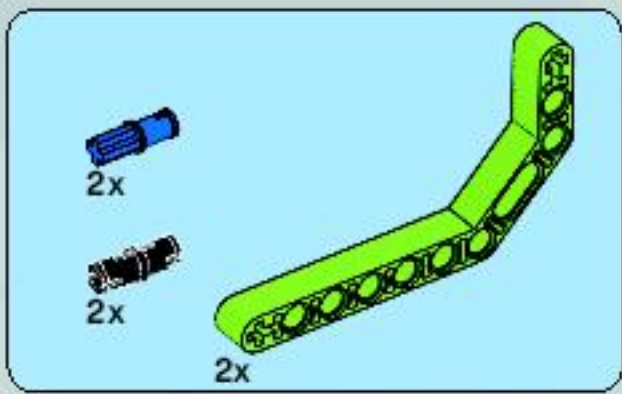

22

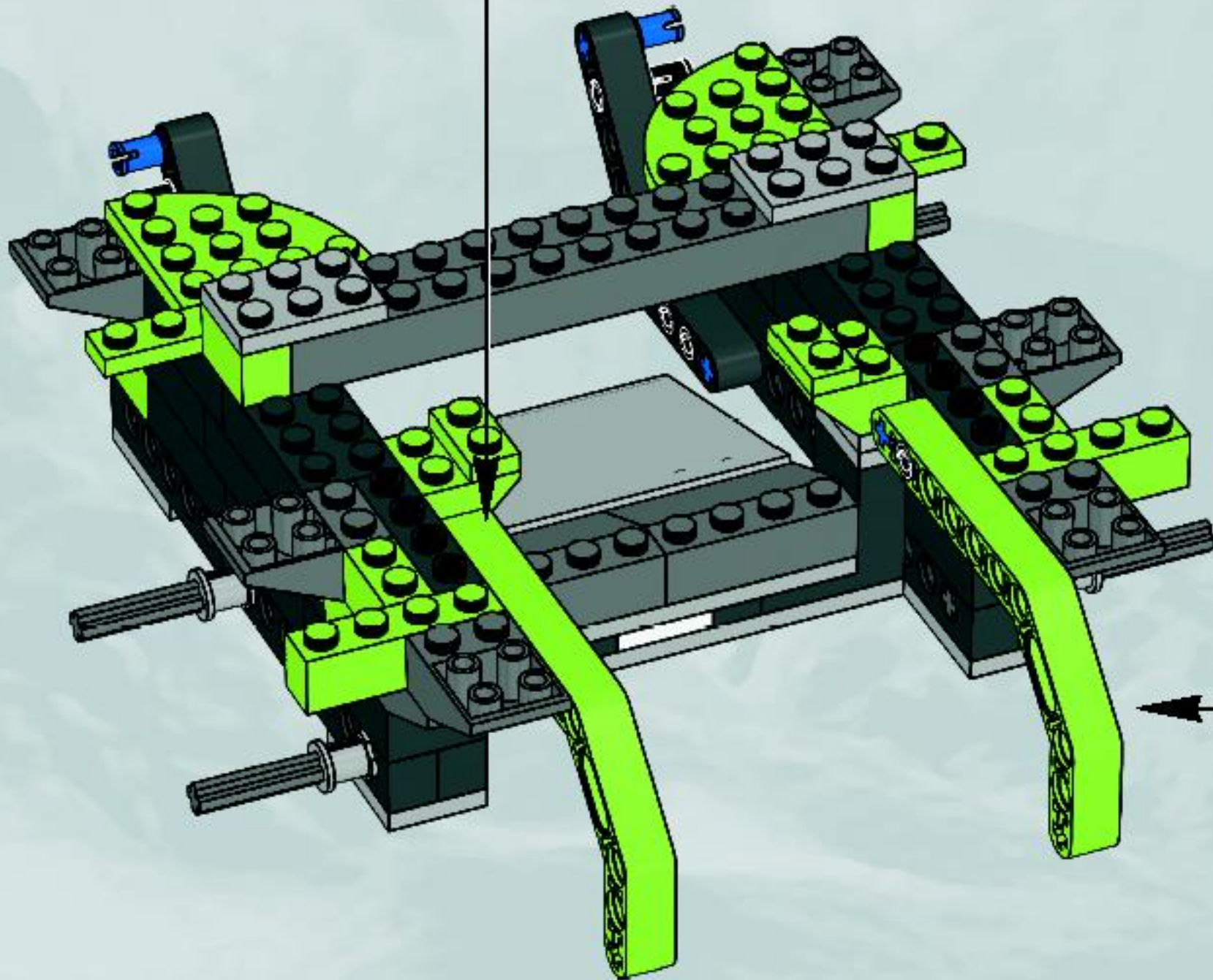
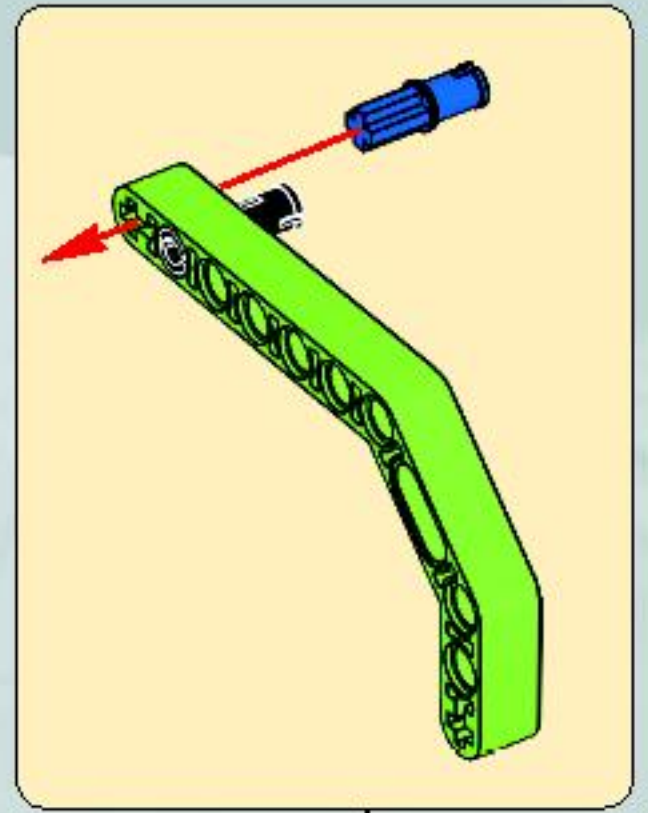
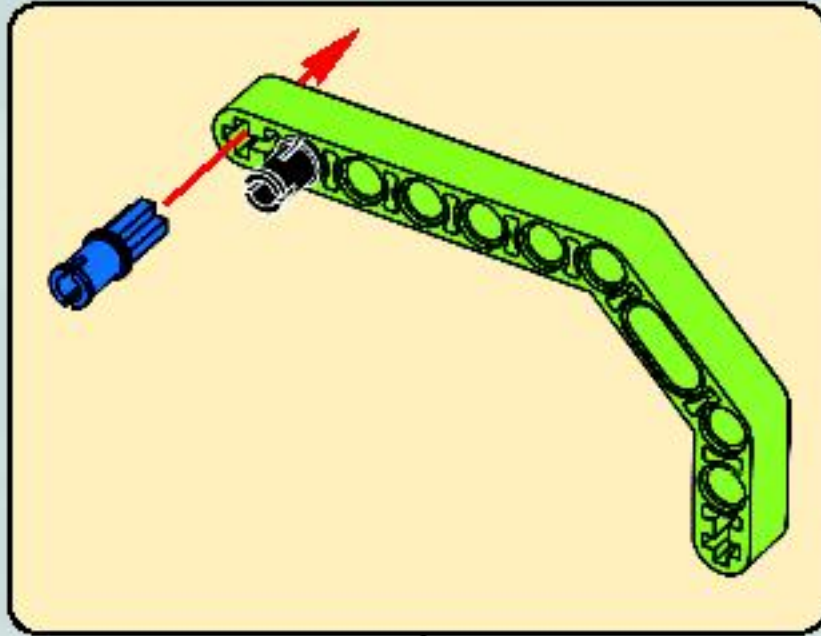

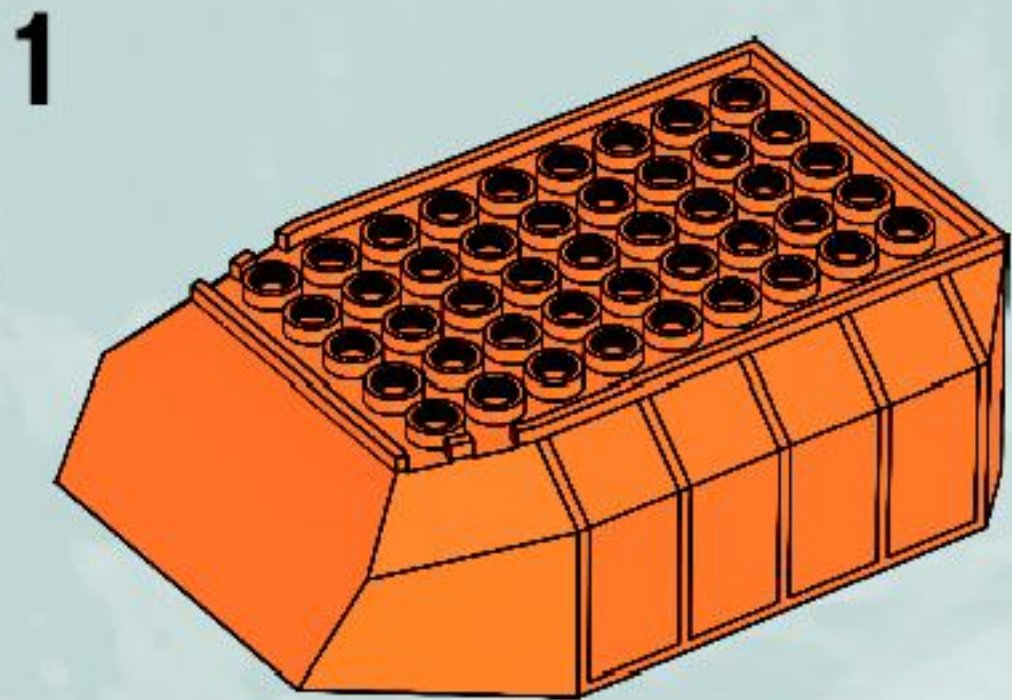
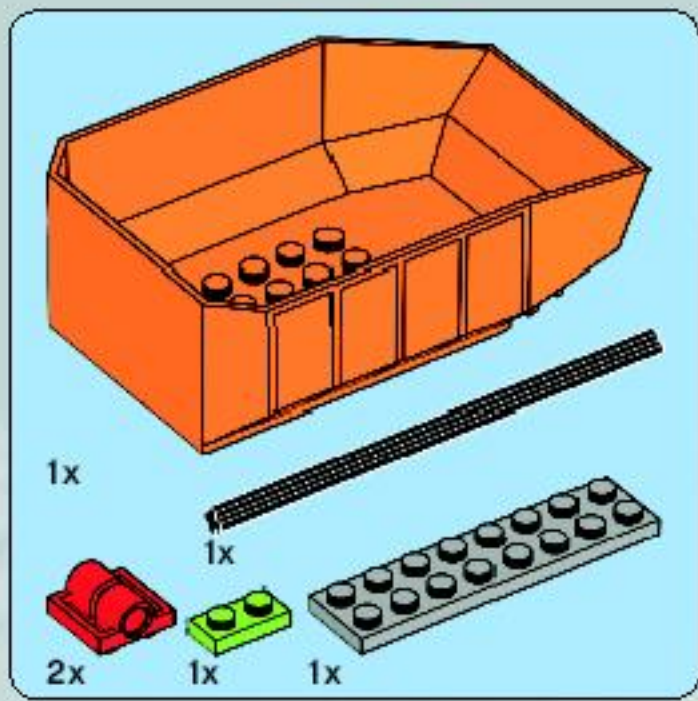

2

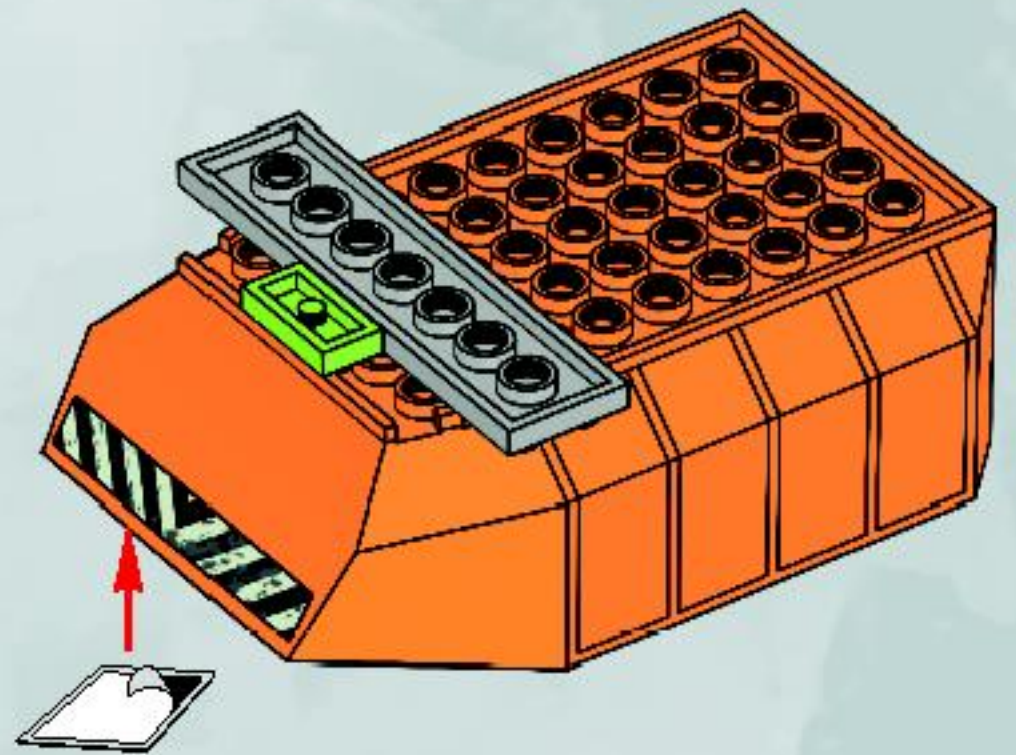

3

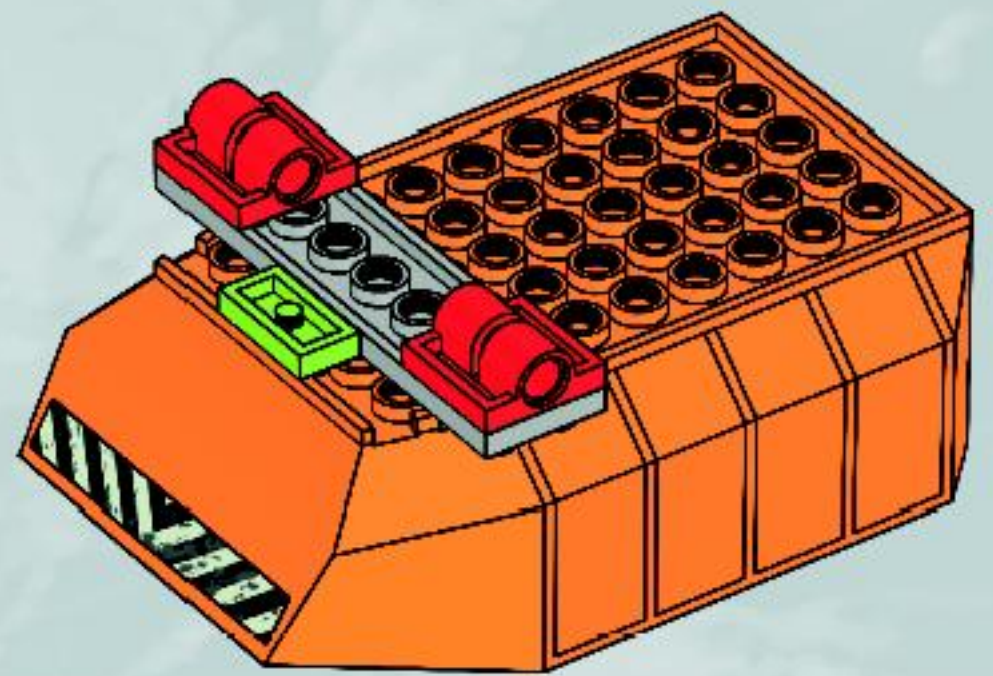



2x



2x

24

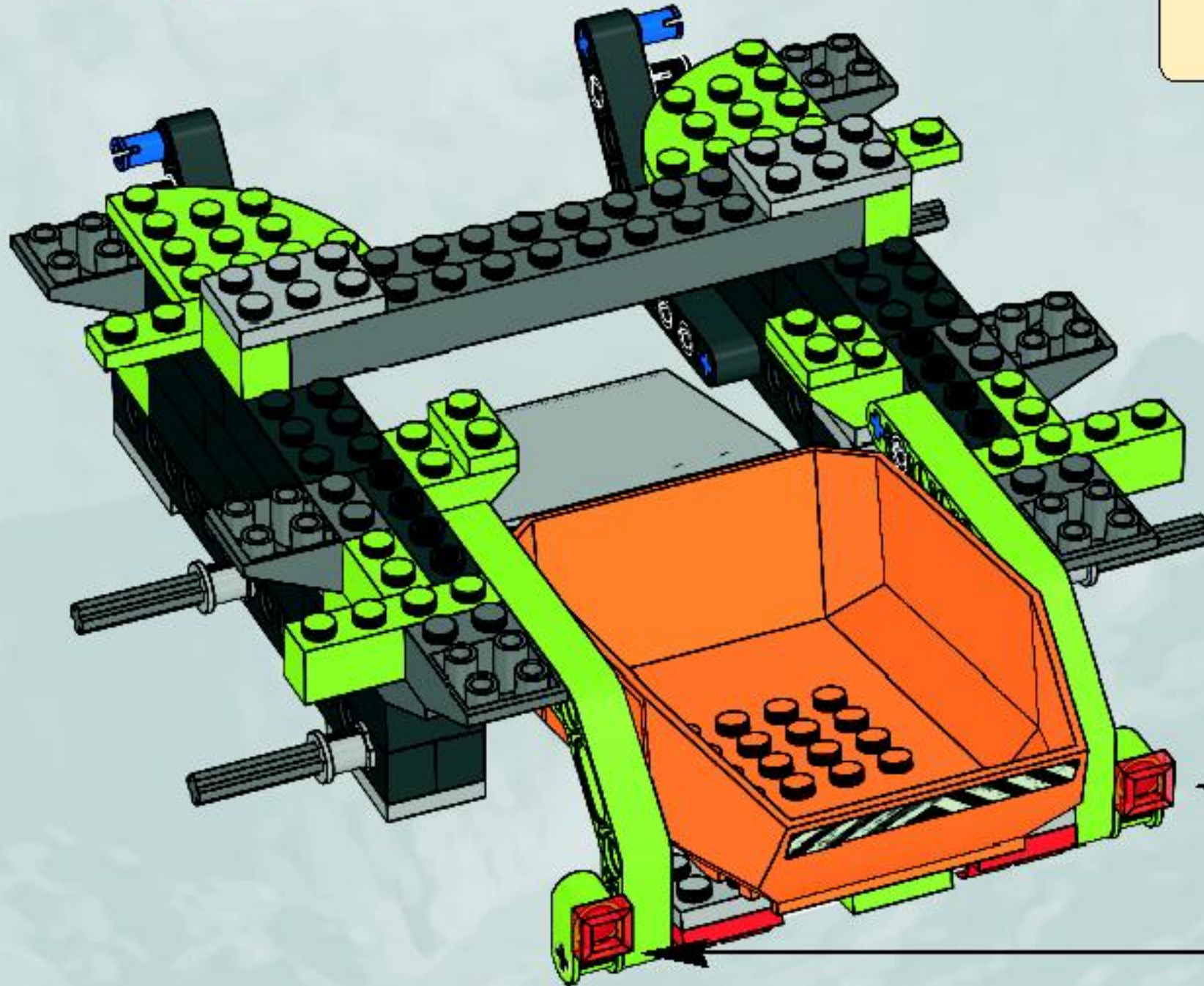

2x

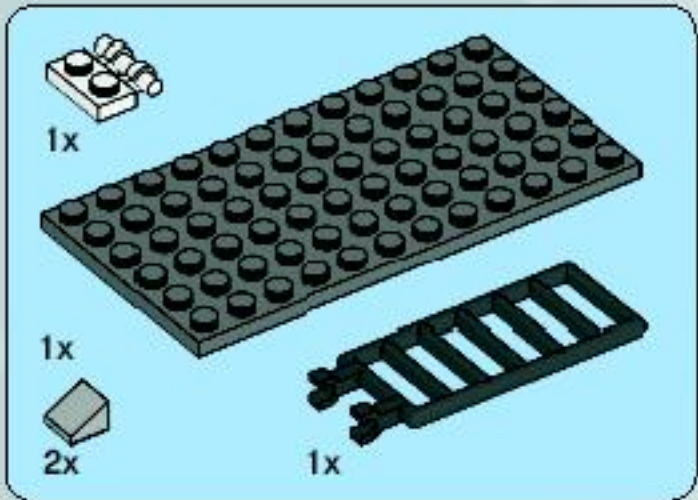
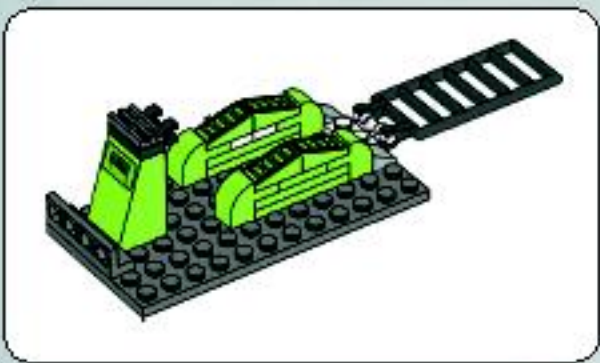
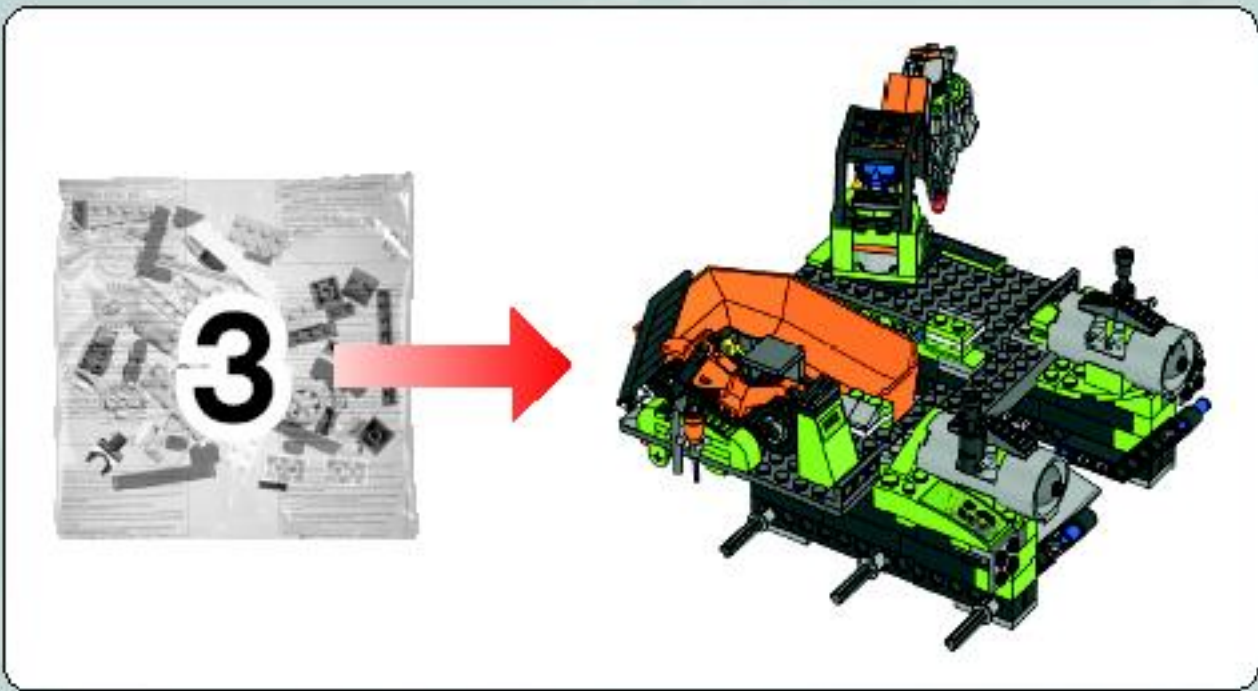

1

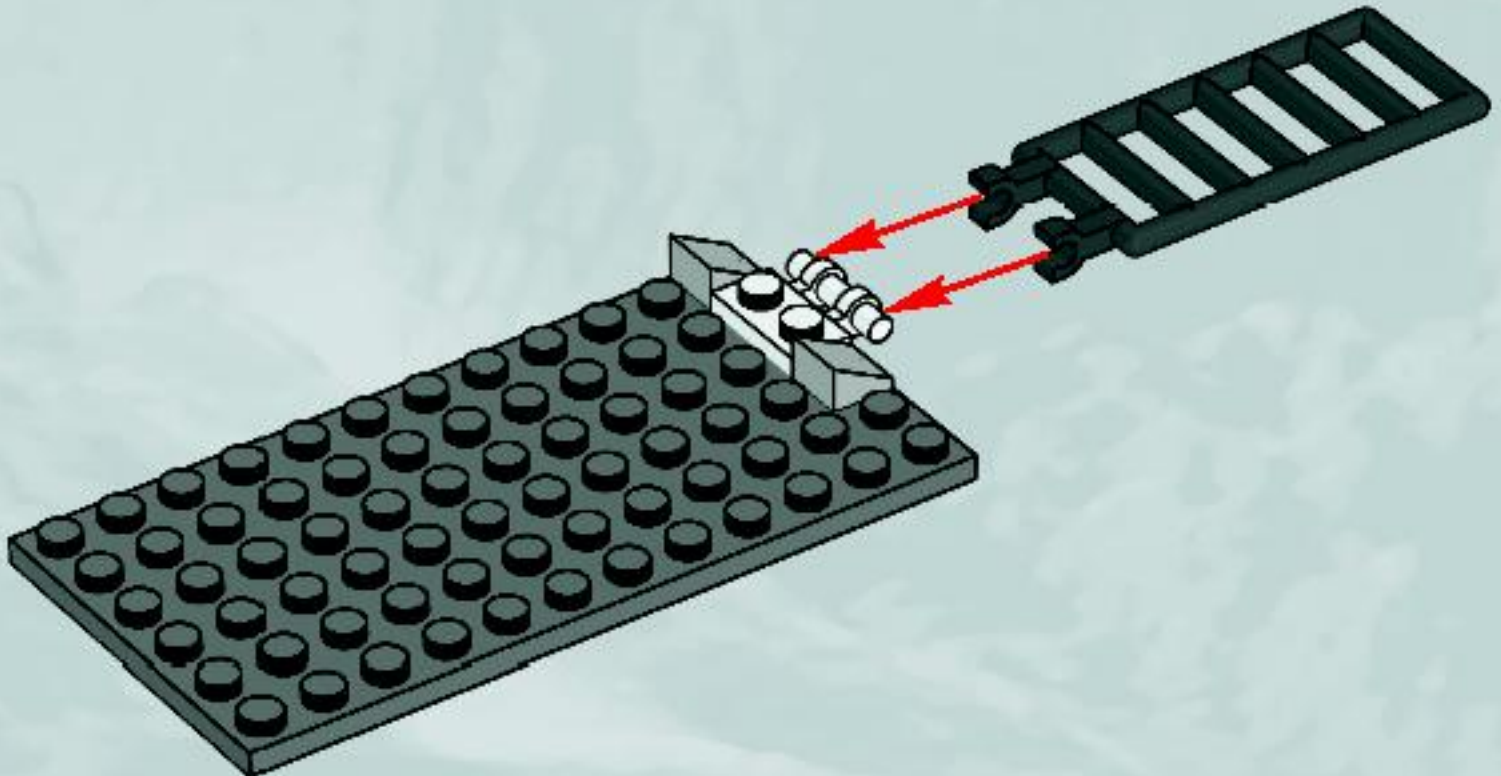

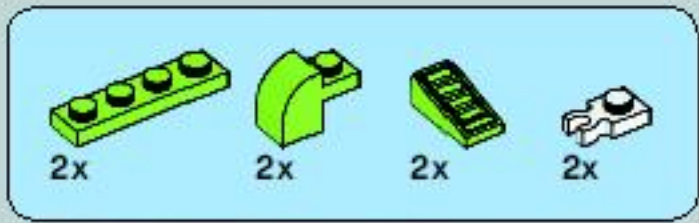

2

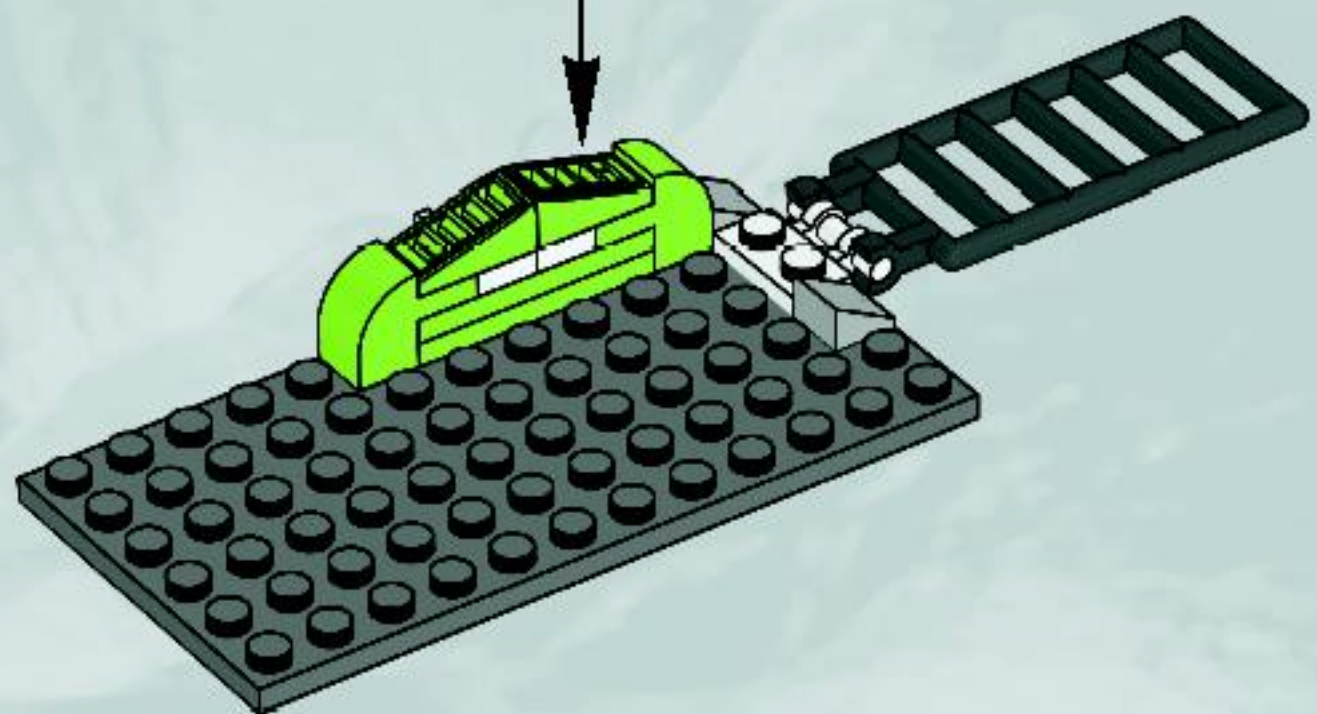
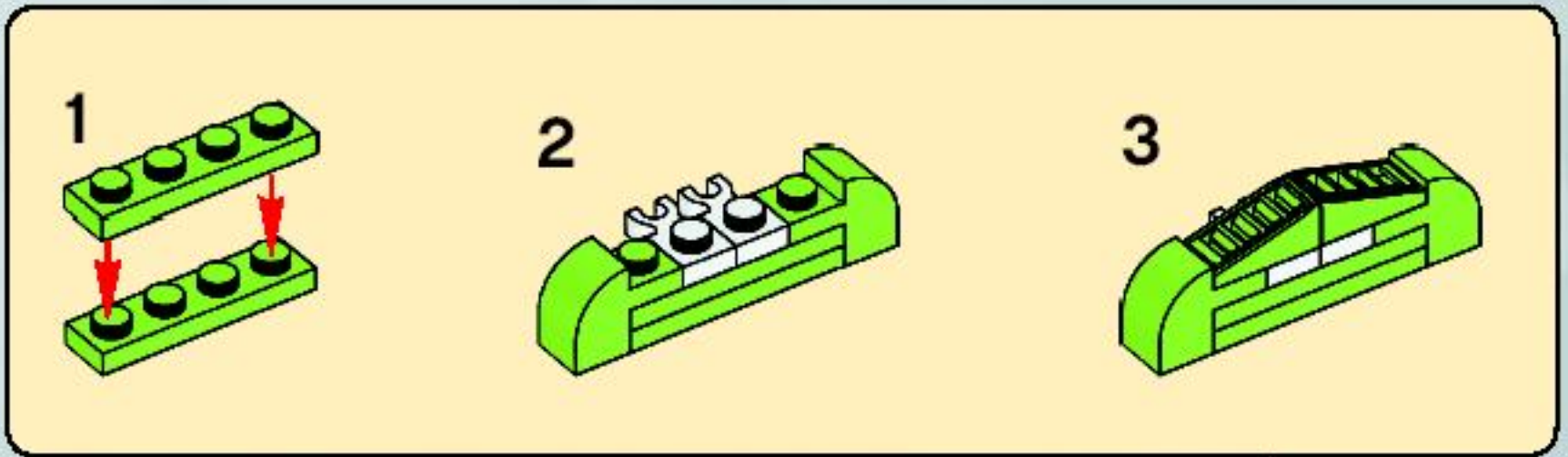

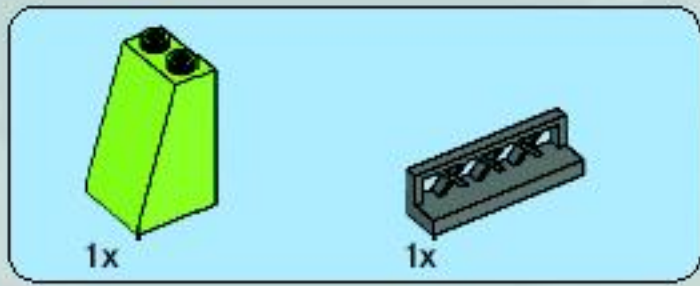

3

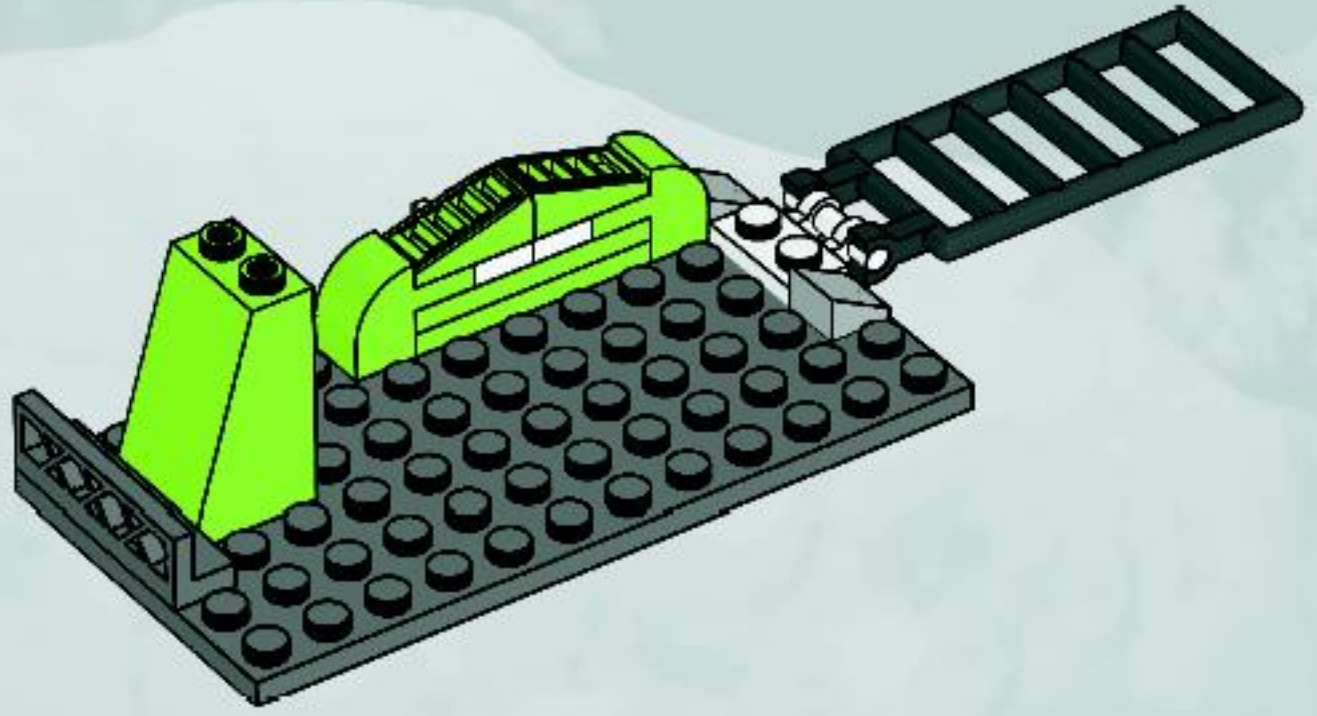

4

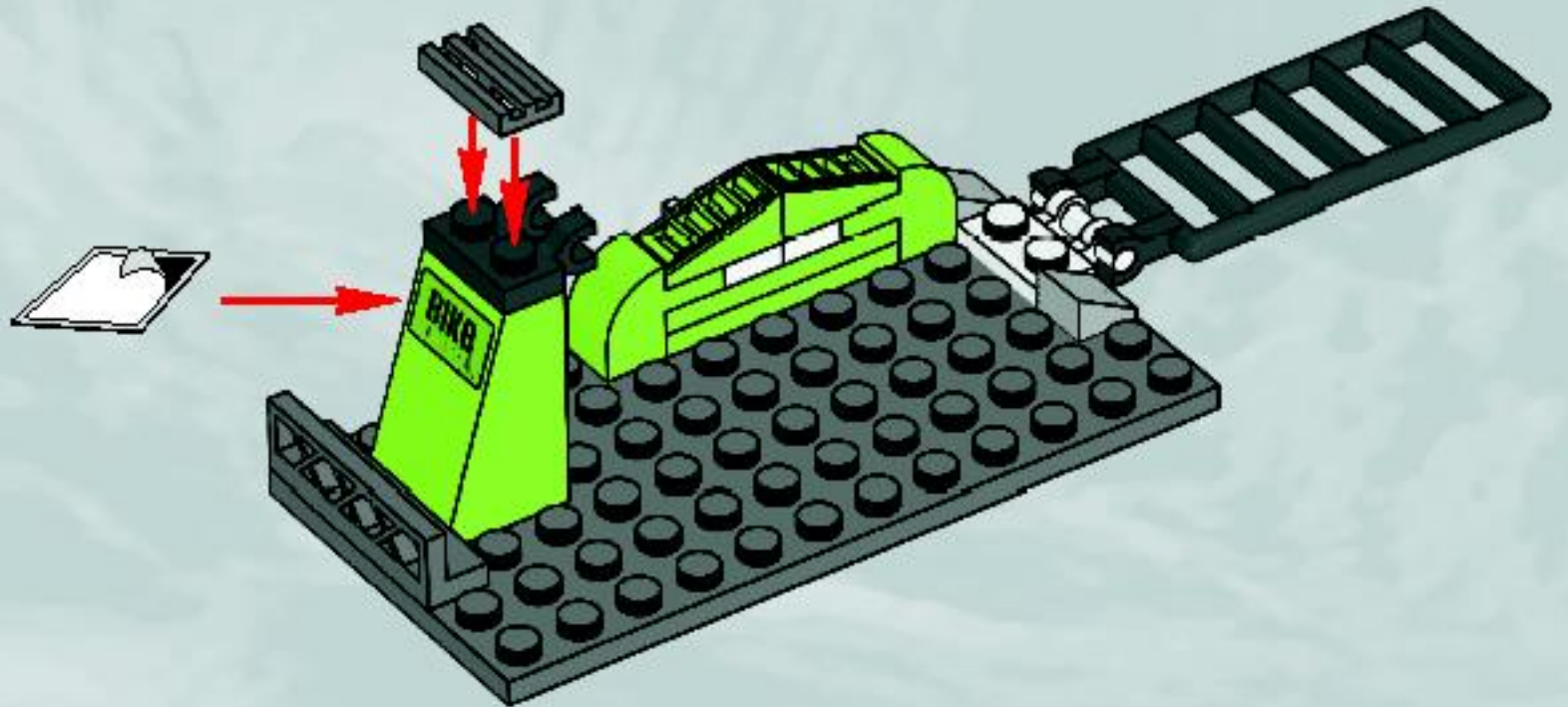

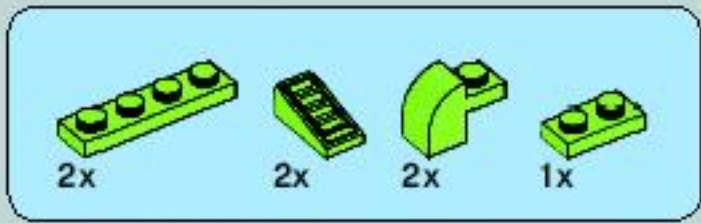

5

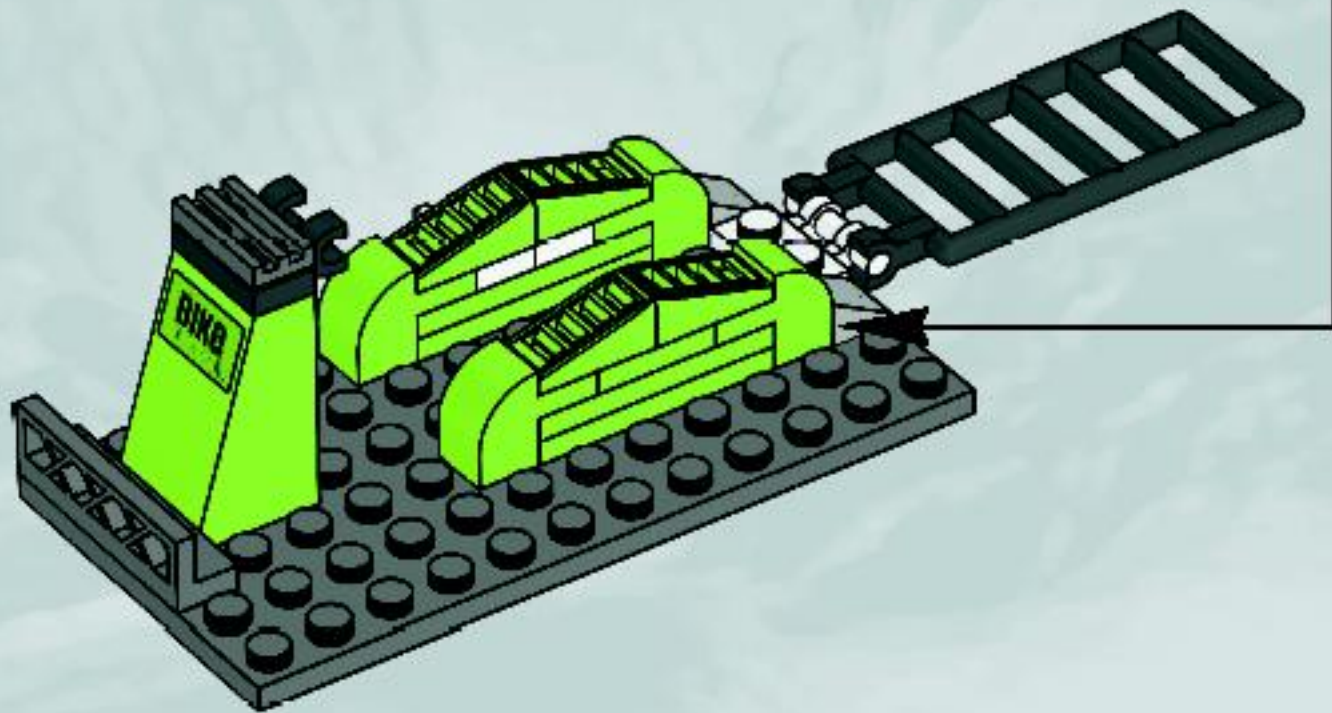
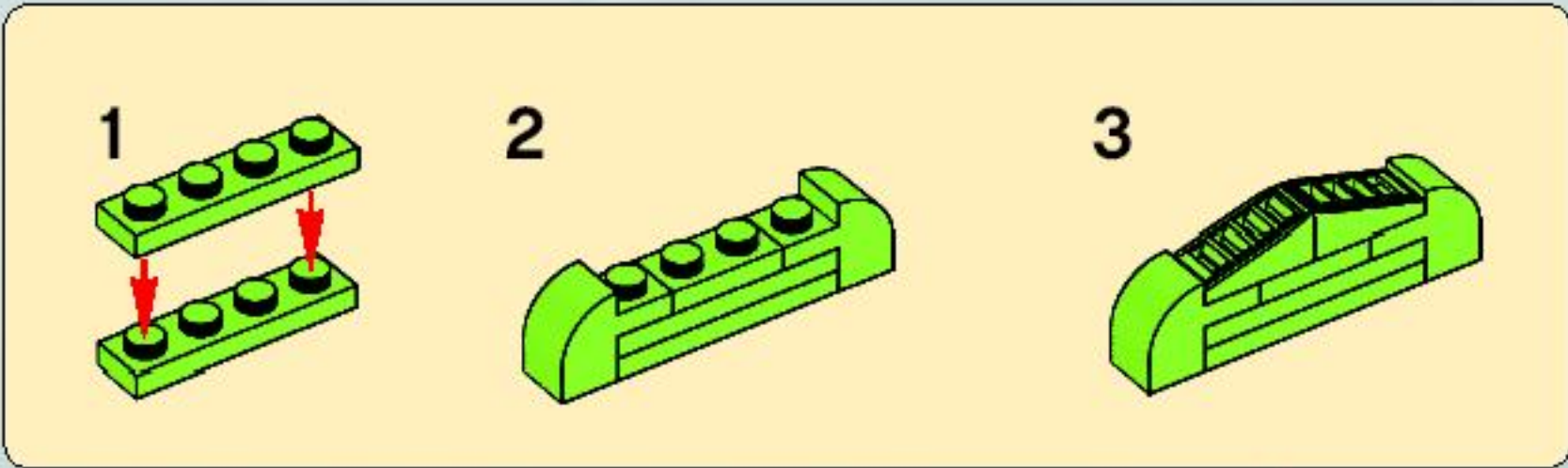



1x



1x

6

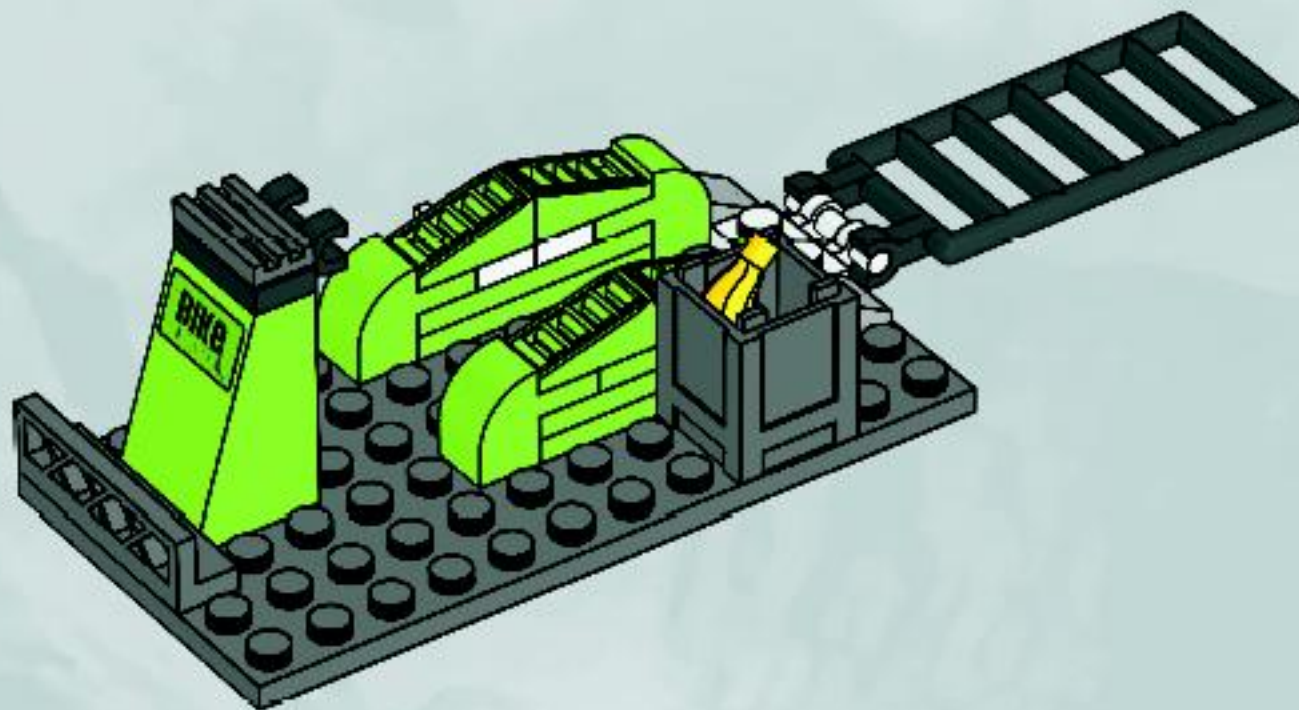

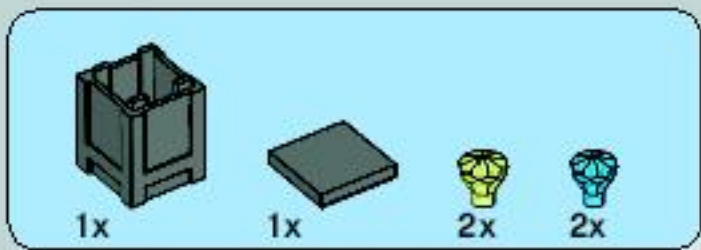

7

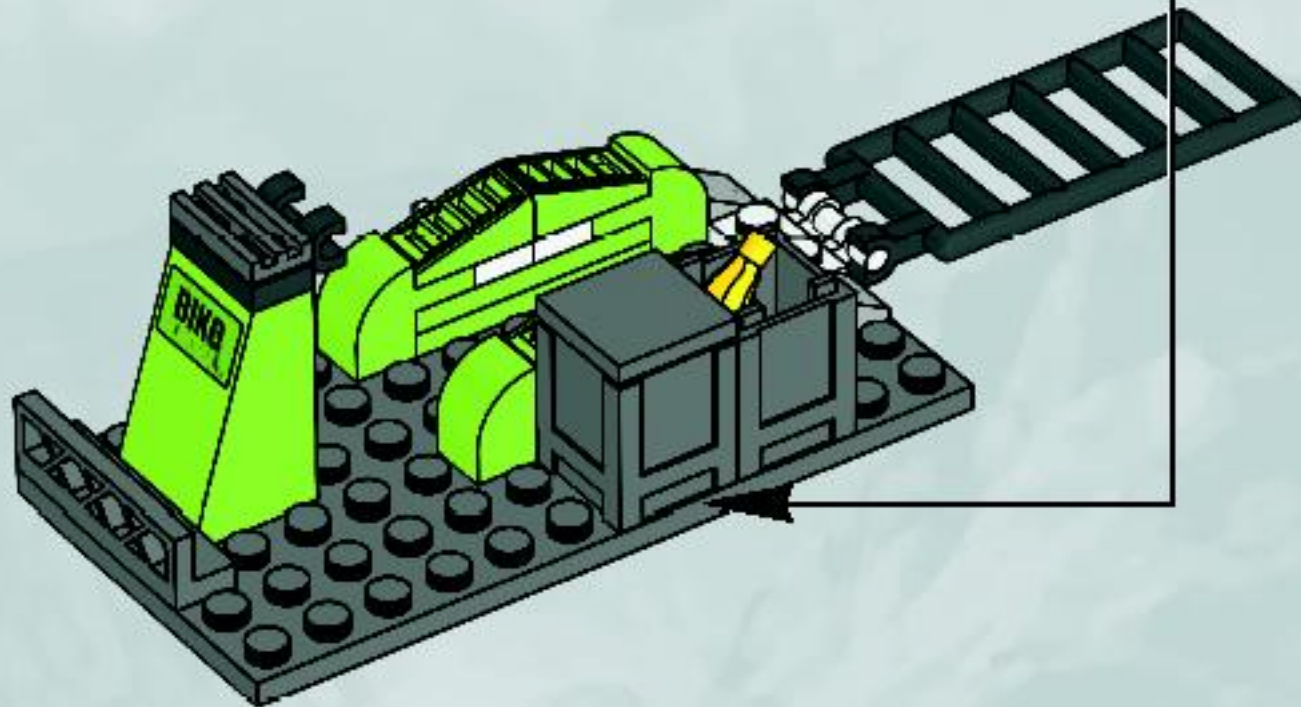
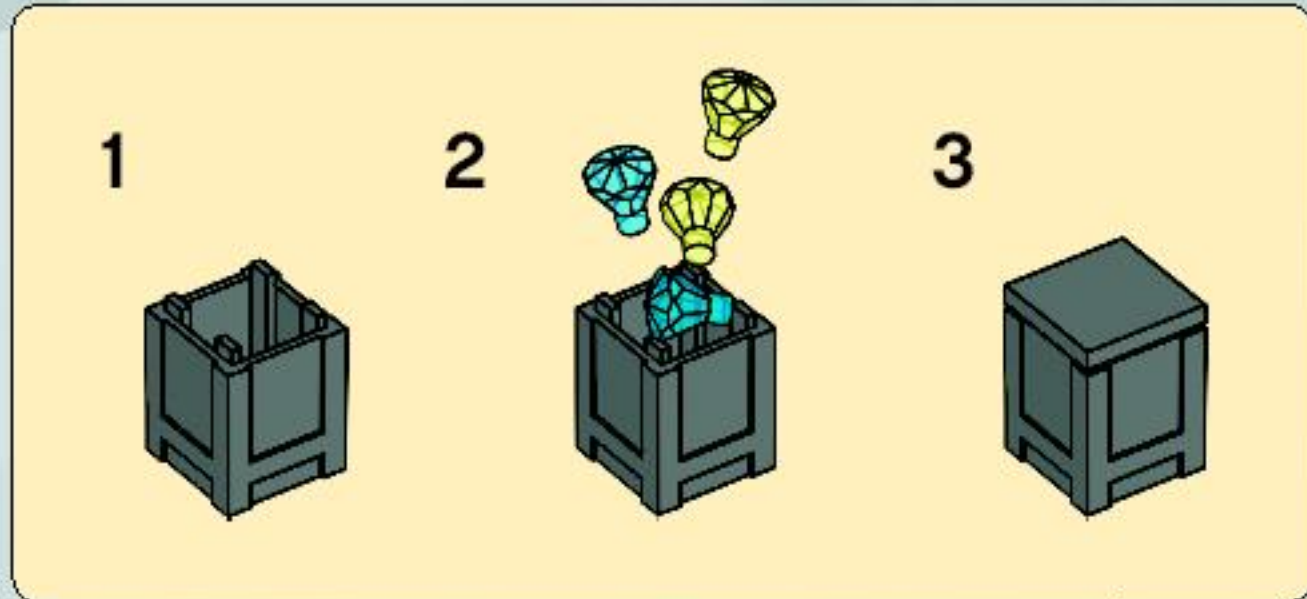

8

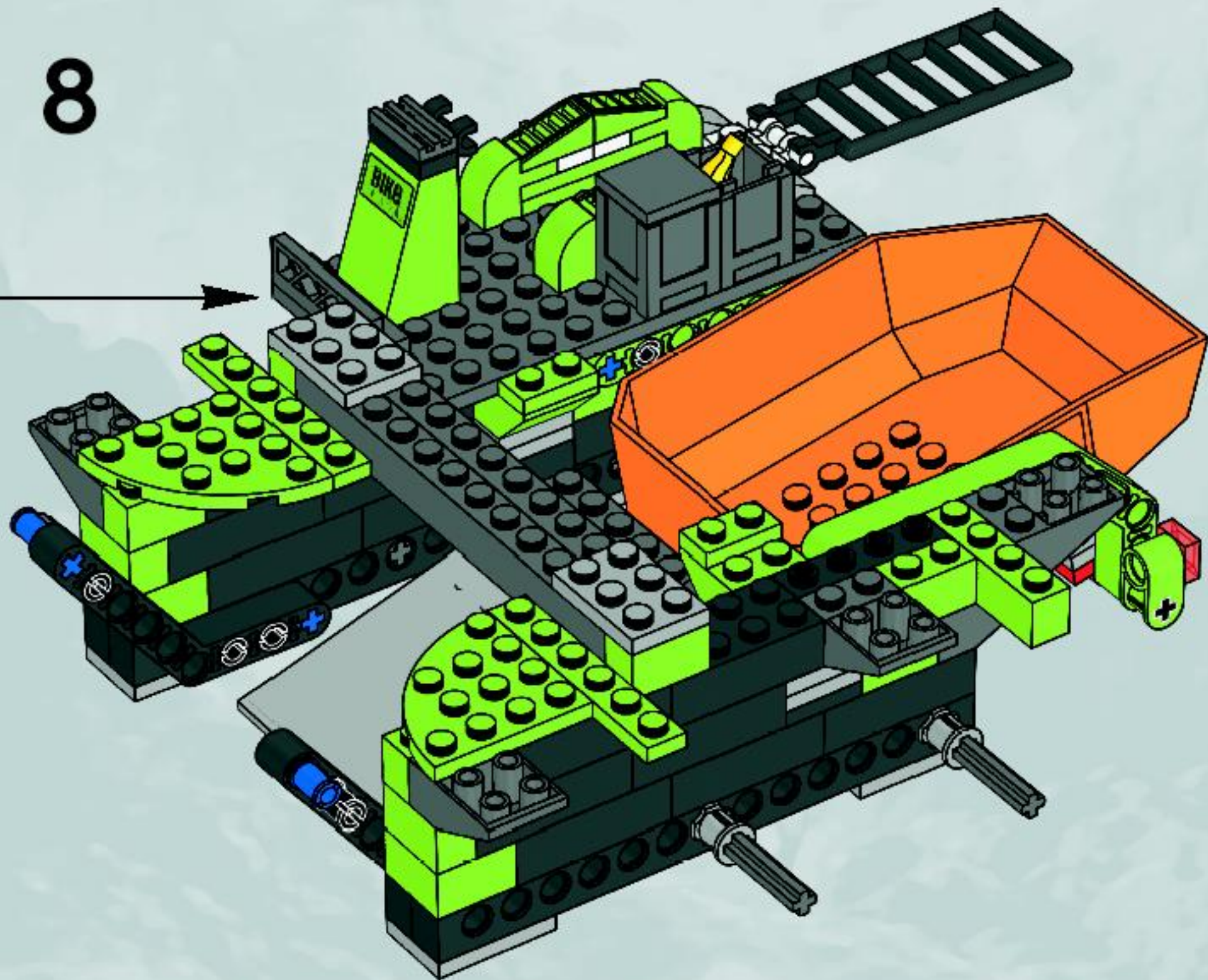

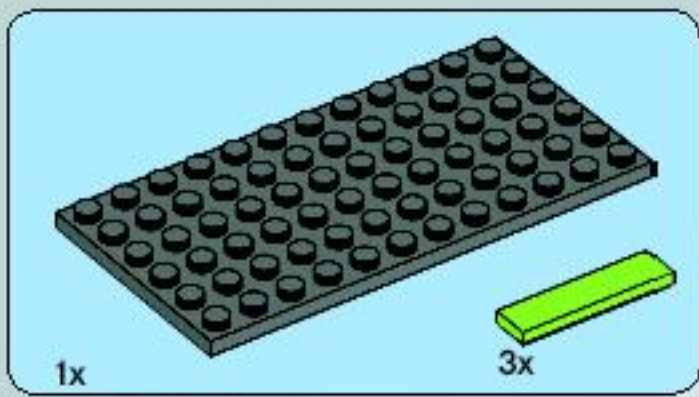

1

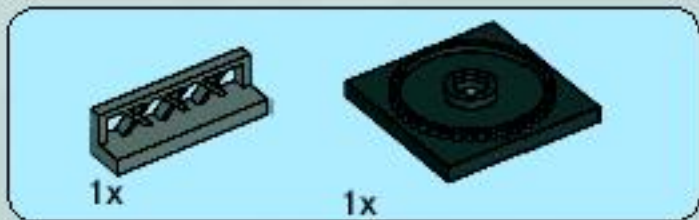
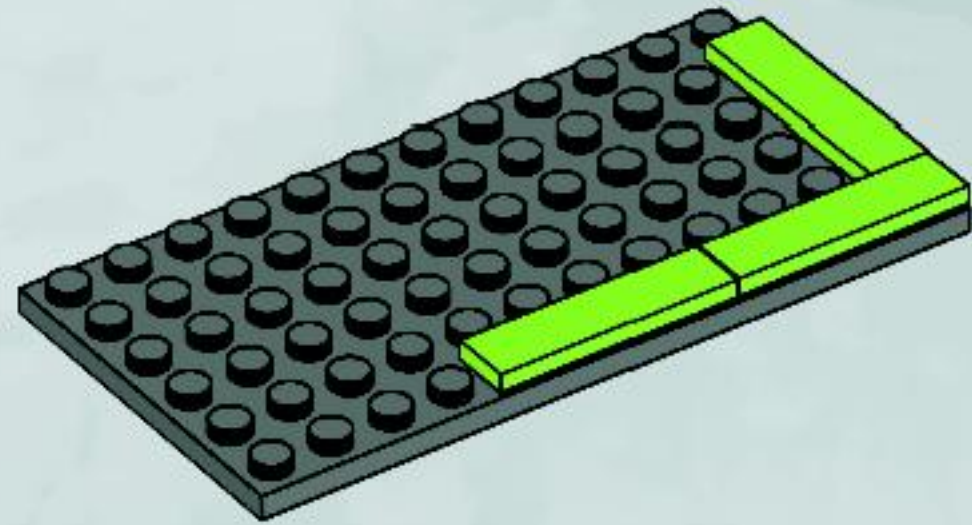

2

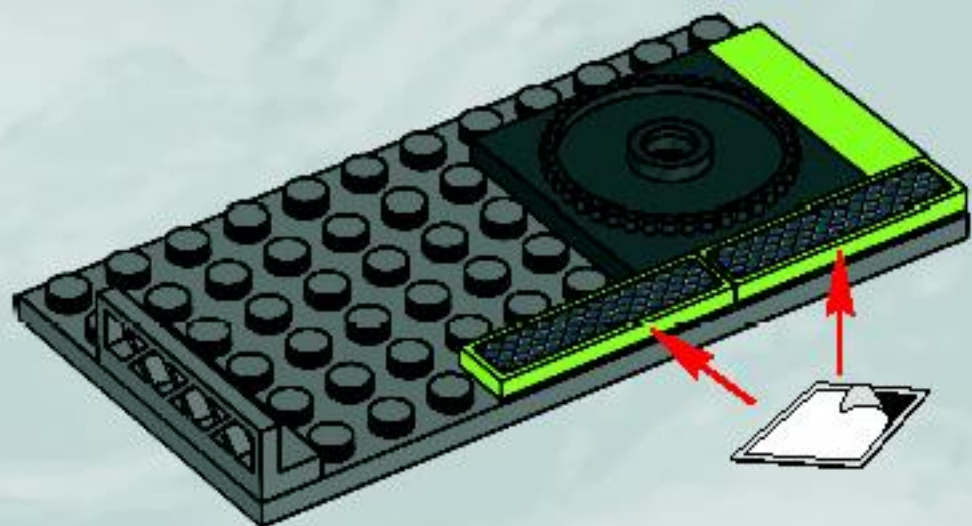

9

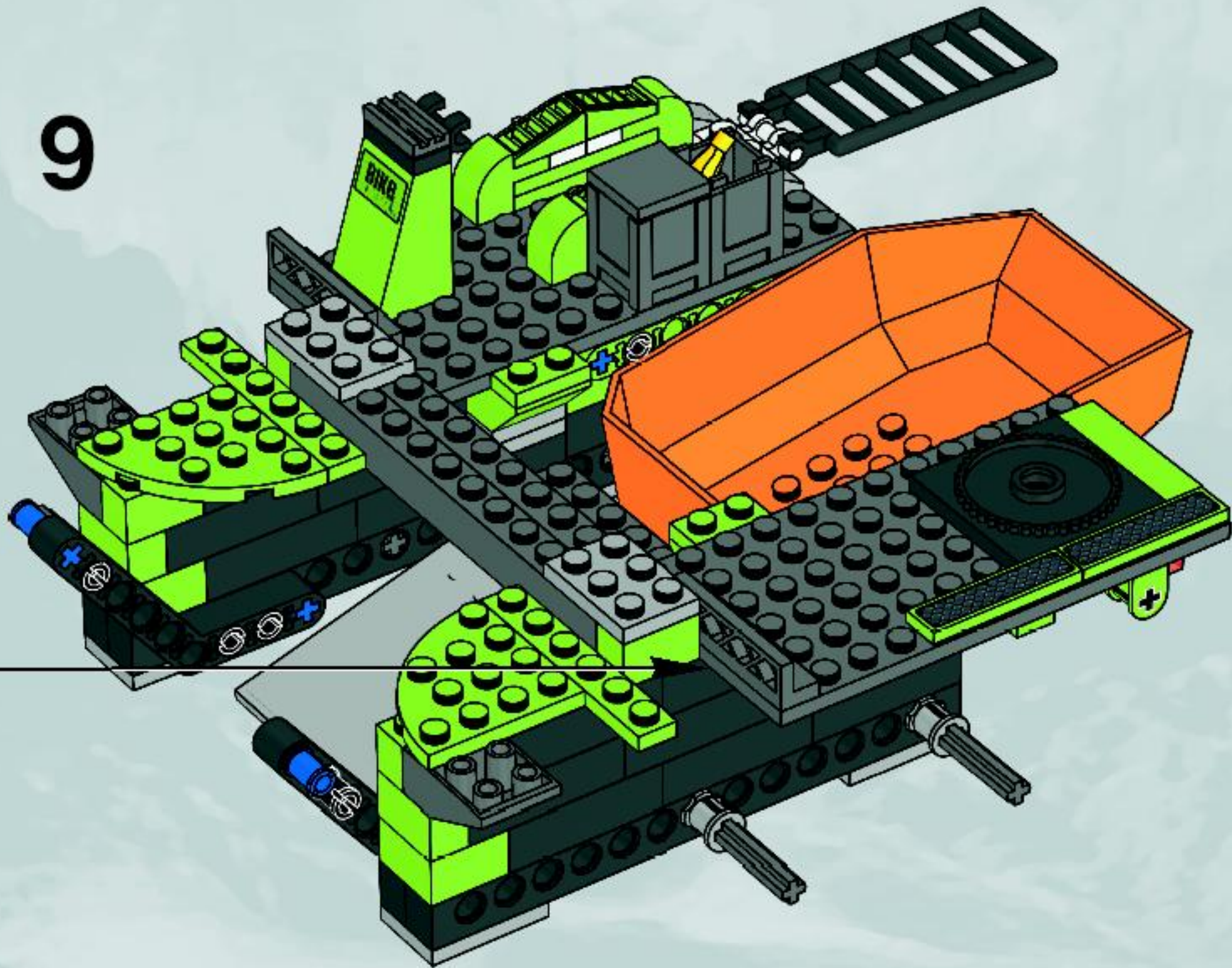

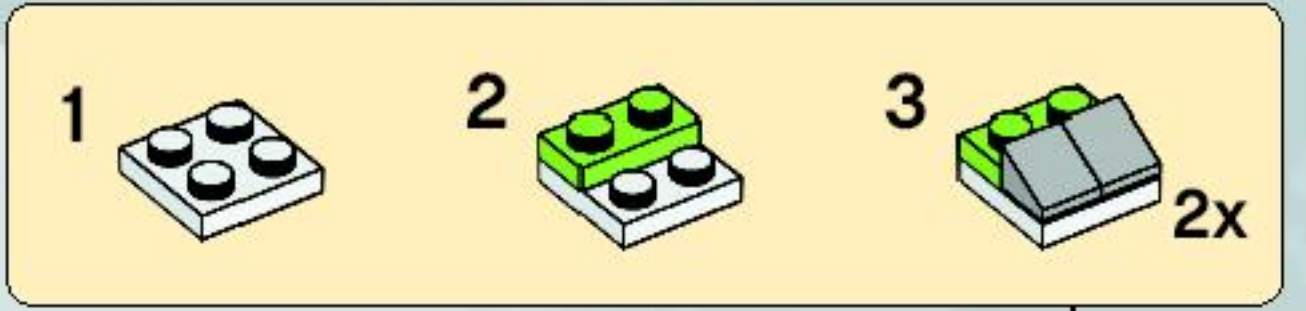
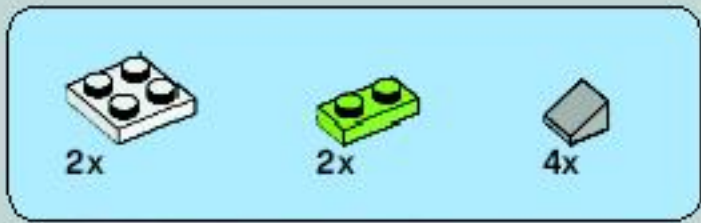

10

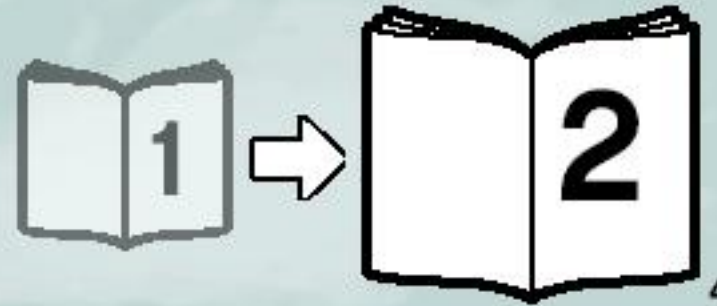
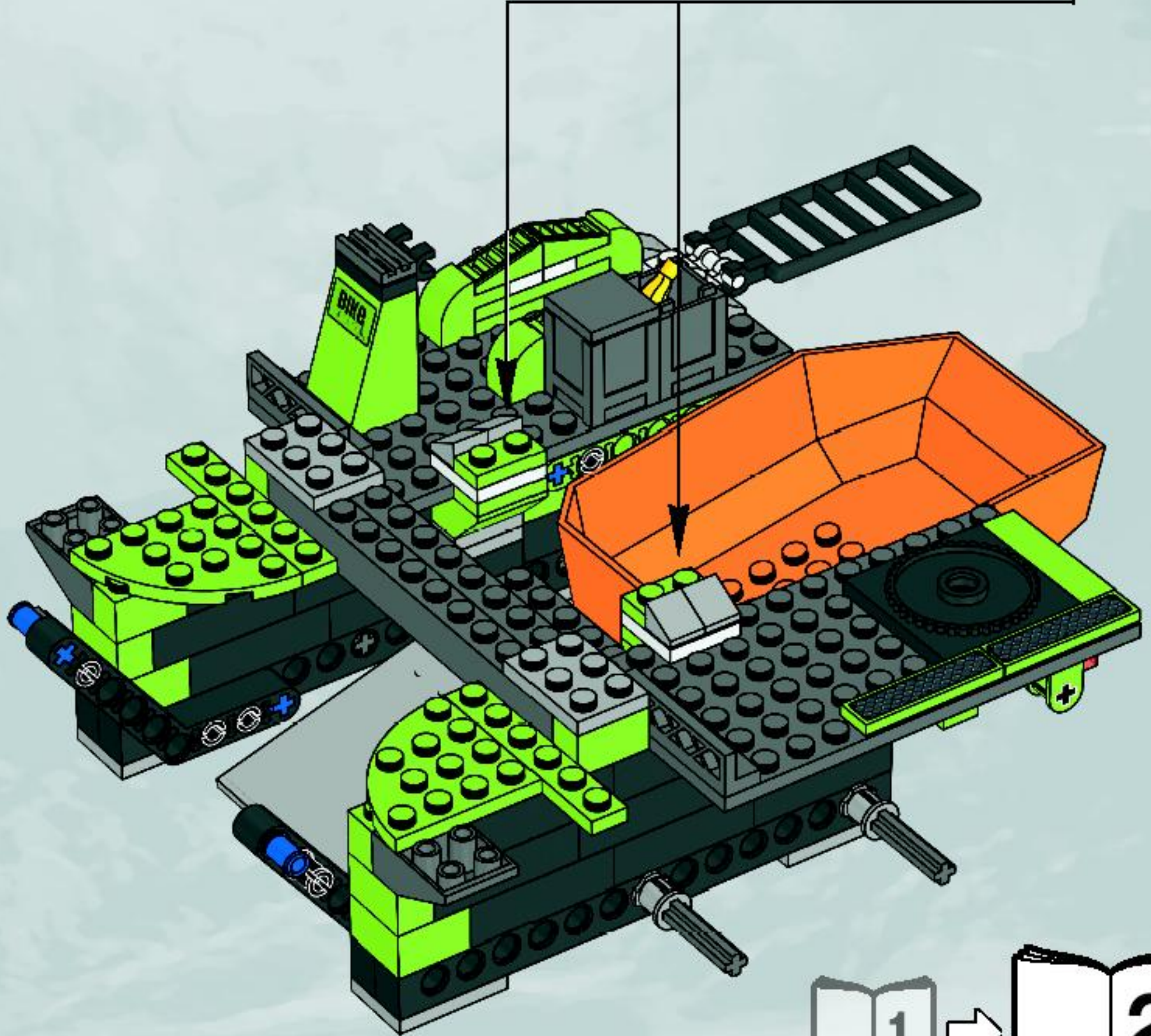

www.nielsen.com/LEGO



WIN LEGO® PRODUCTS

Fill out a survey and you might WIN a cool LEGO product
NO PURCHASE NECESSARY

Open to all residents where not prohibited
Go to www.nielsen.com/dk/LEGO to fill out a survey for a chance to win a LEGO product.

WIN LEGO® PRODUCTEN

Vul een enquêteformulier in en maak kans op een cool LEGO® product
Kopen niet nodig
Iedereen uit landen waar geen enquêteverbod geldt mag deelnemen.
Ga naar www.nielsen.com/dk/LEGO, vul een enquêteformulier in en maak kans op een LEGO product.

GEWINNE LEGO® PRODUKTE

Nimm an der Umfrage teil und GEWINNE ein tolles LEGO® Produkt!
Die Teilnahme am Gewinnspiel führt zu keinerlei Kaufverpflichtungen
Teilnahme in allen nicht ausgeschlossenen Ländern möglich
Wir verlosen unter allen Teilnehmern der Umfrage auf www.nielsen.com/dk/LEGO LEGO Produkte.

GAGNE DES PRODUITS LEGO®

Réponds à un questionnaire et tu pourrais GAGNER un produit LEGO® très cool !
Aucune obligation d'achat.
Ouvert à tous les résidents des pays autorisés.
Visite www.nielsen.com/dk/LEGO pour répondre à un questionnaire et avoir une chance de gagner un produit LEGO.

レゴ®製品を「当てよう」

アンケートに記入して、カッコいいレゴ®製品を当てよう！
お買い上げの必要はありません。
禁止されていない限り、すべての皆様にご利用いただけます。
www.nielsen.com/dk/LEGOにアクセスして、アンケートにご記入ください。当選者にはレゴ®製品を差し上げます。



©2009 The LEGO Group. 4549565



POWER MINERS

8961



1

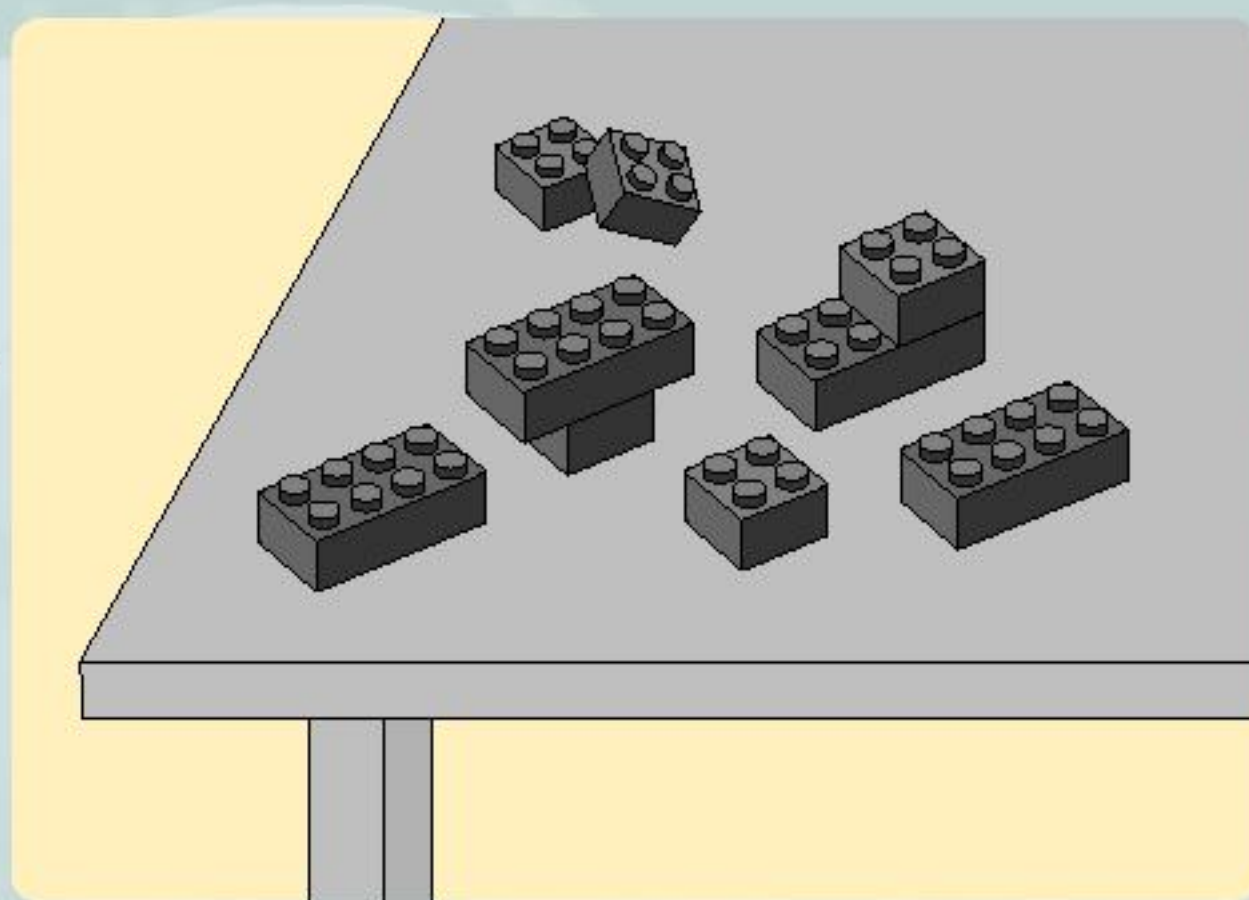
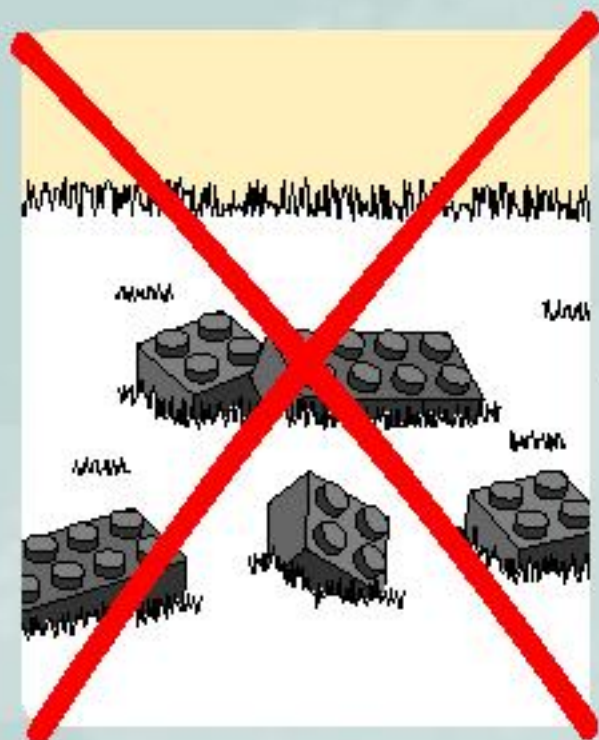

2



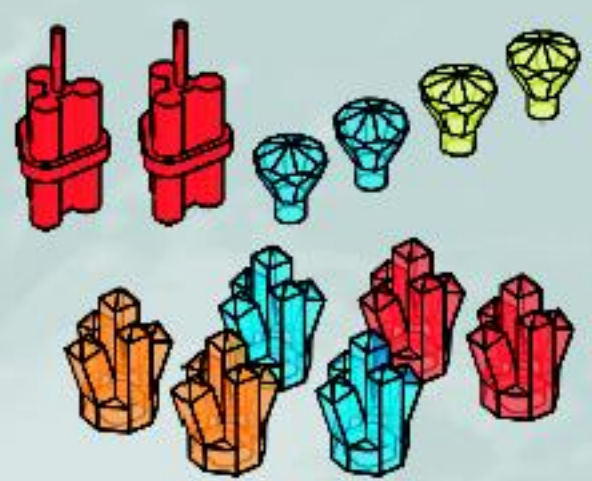
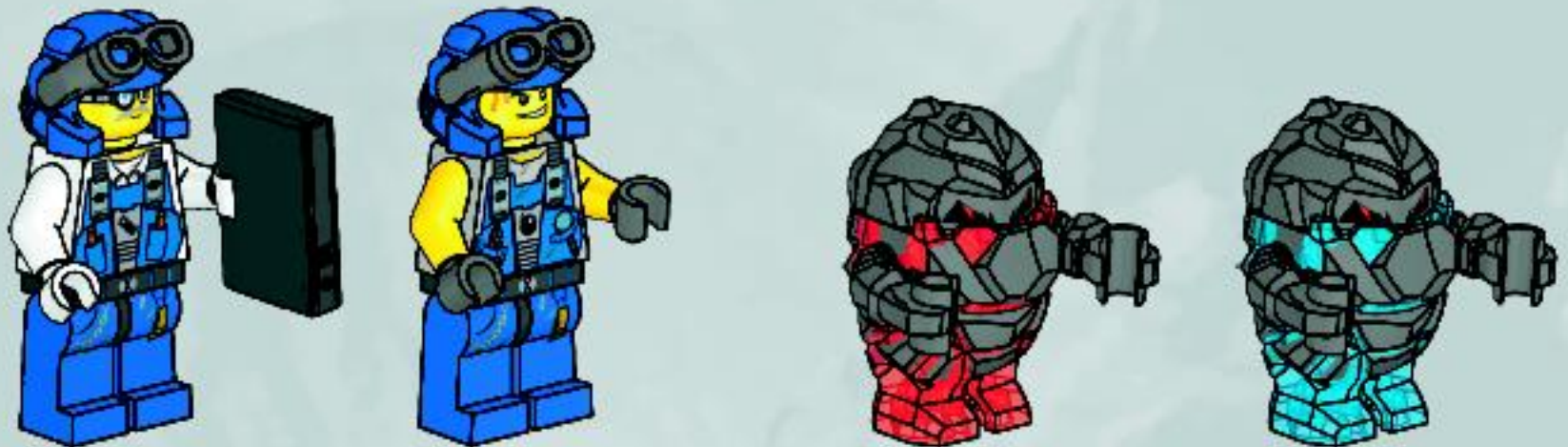
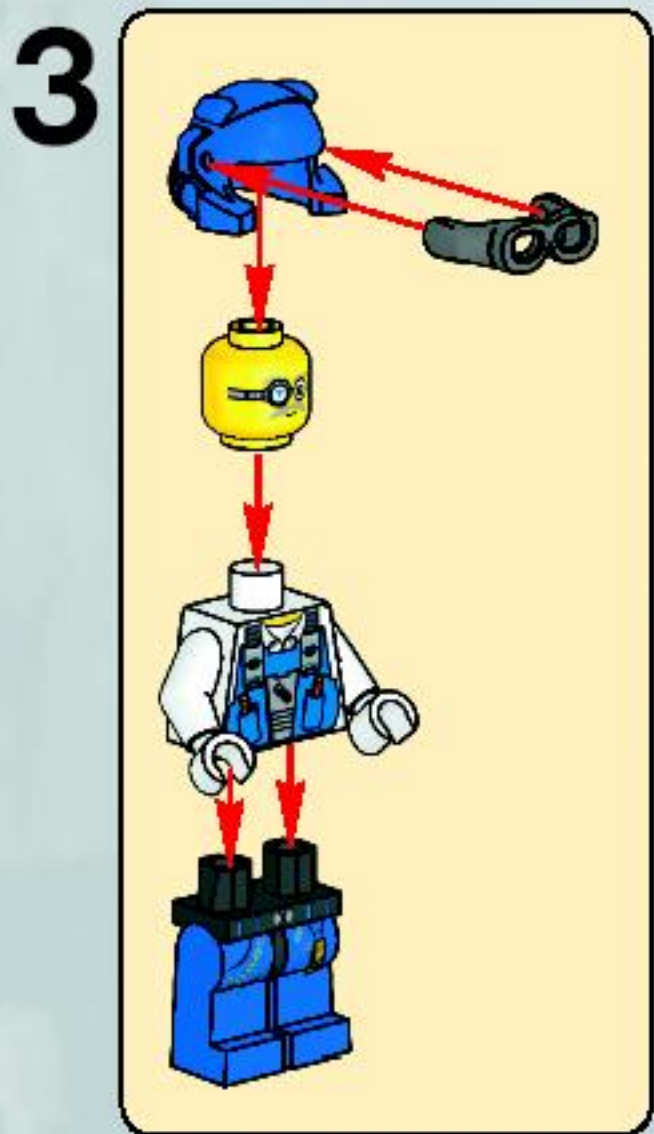
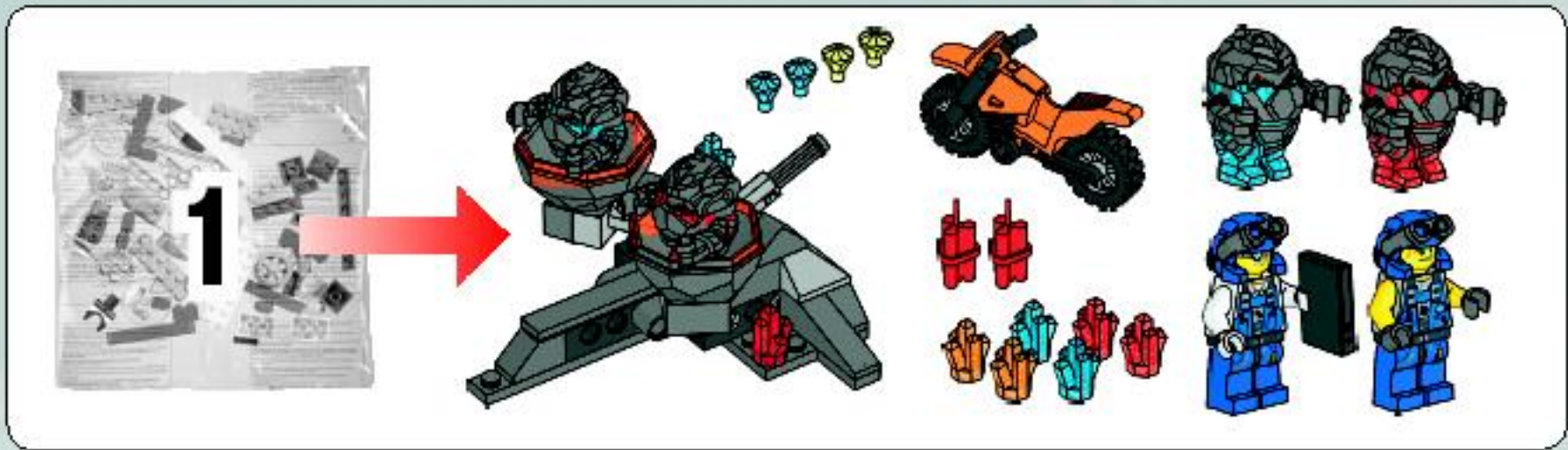

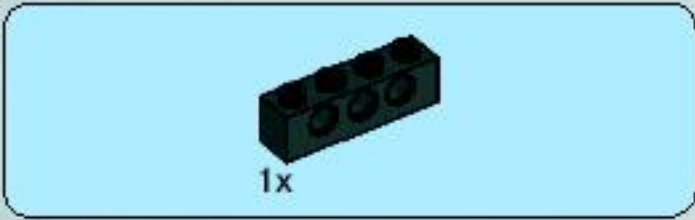
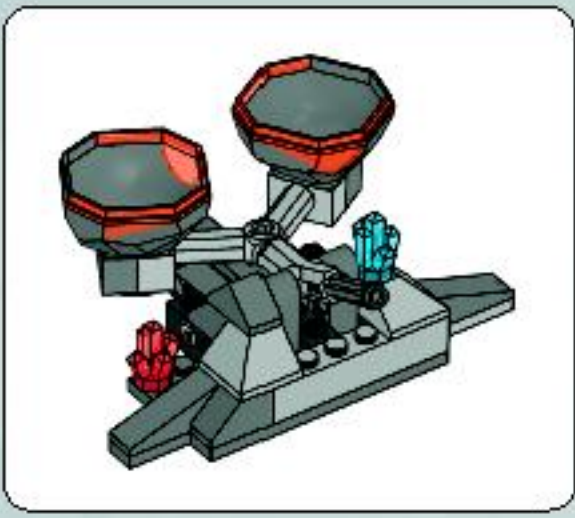

1



2

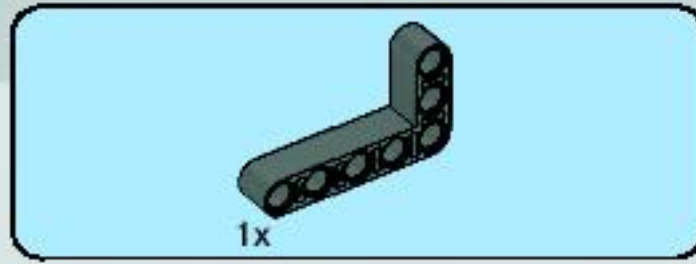
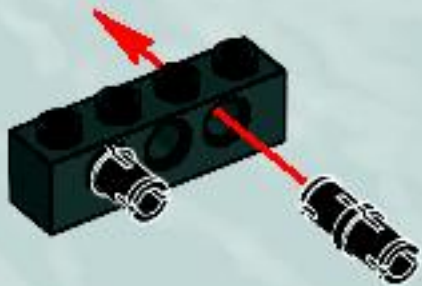

3

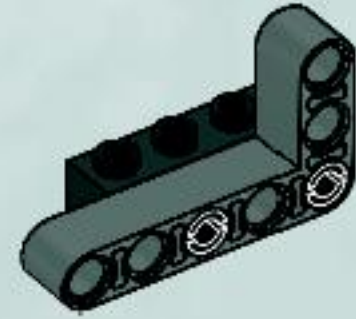

4

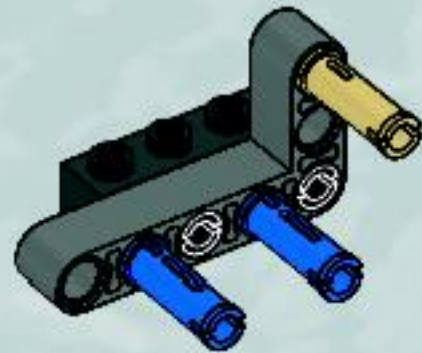

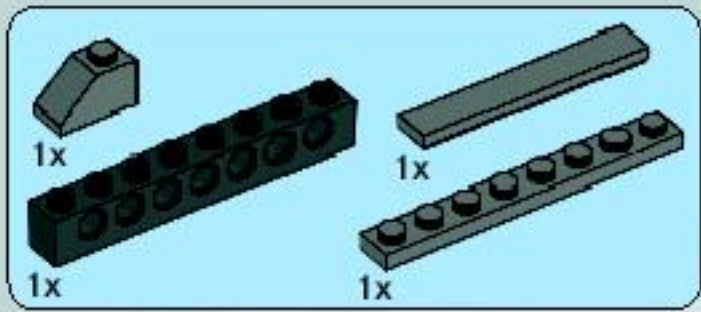

5

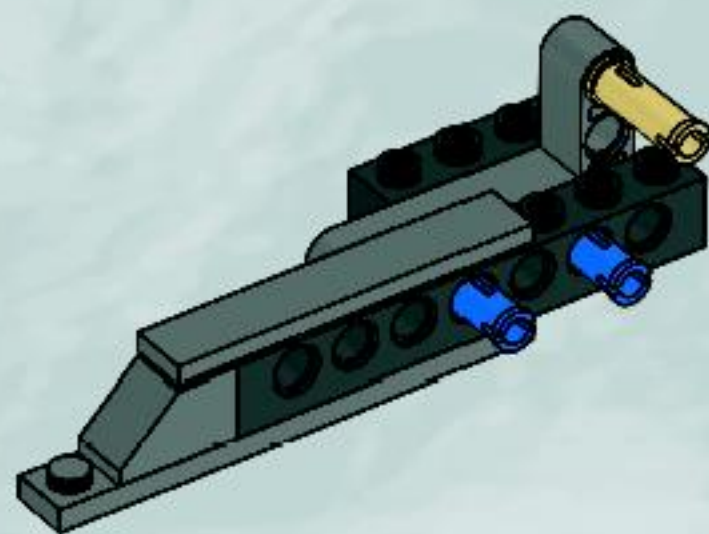
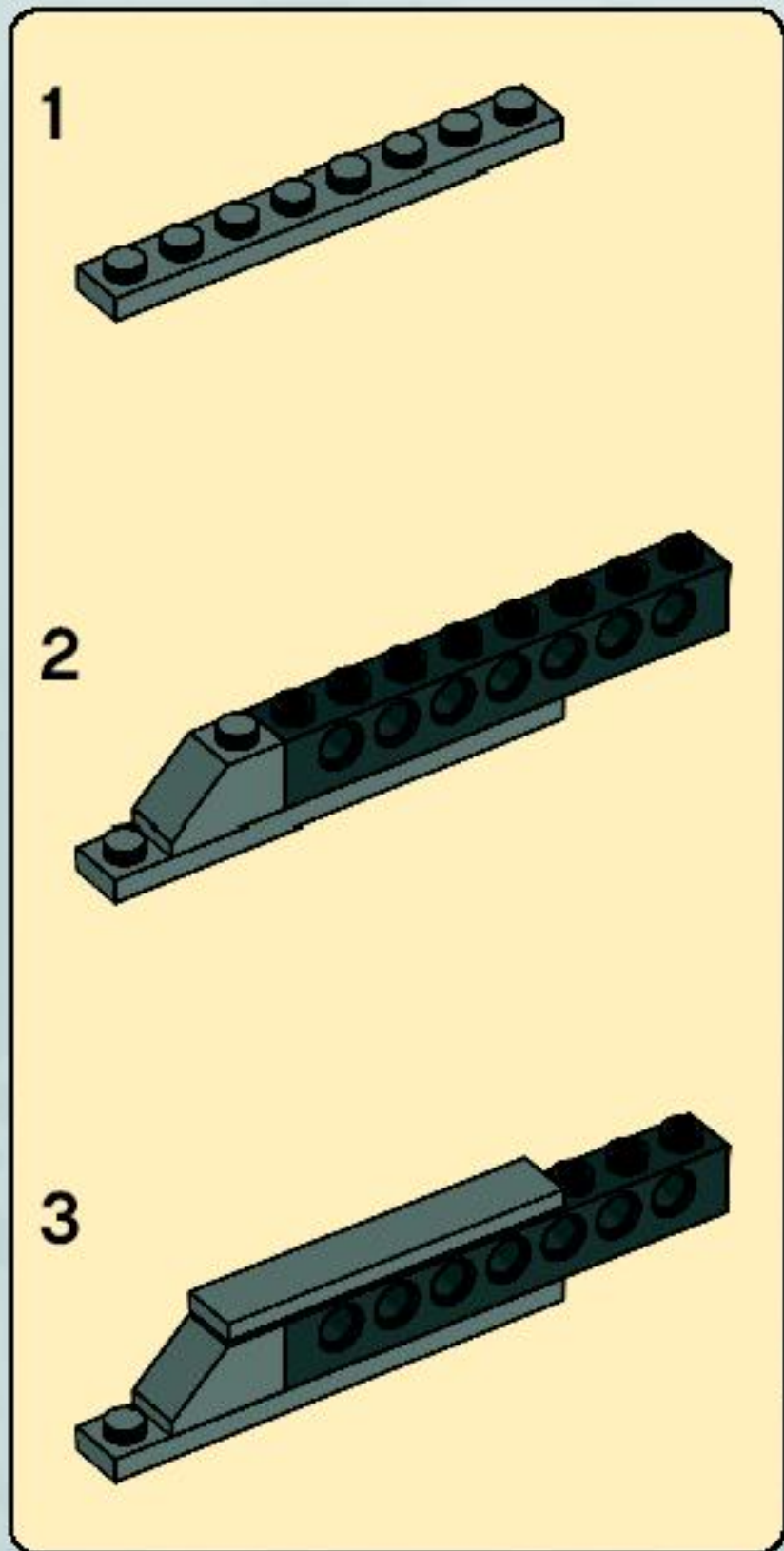



1x

6

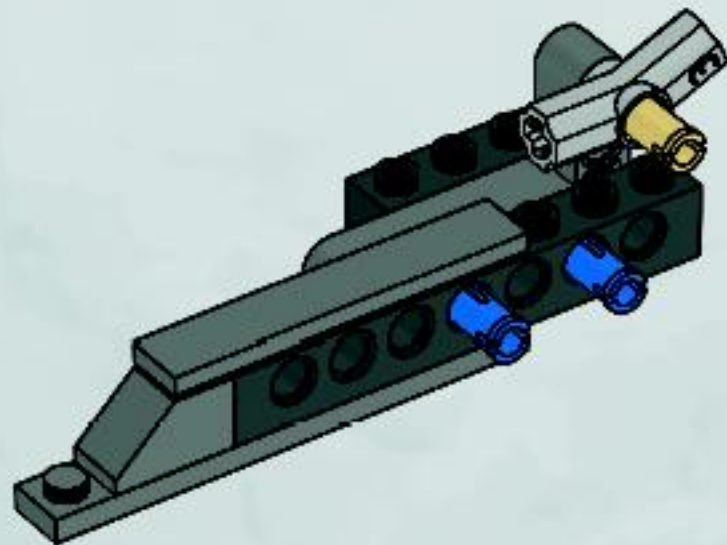

2x

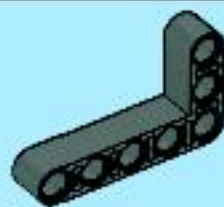

1x

7

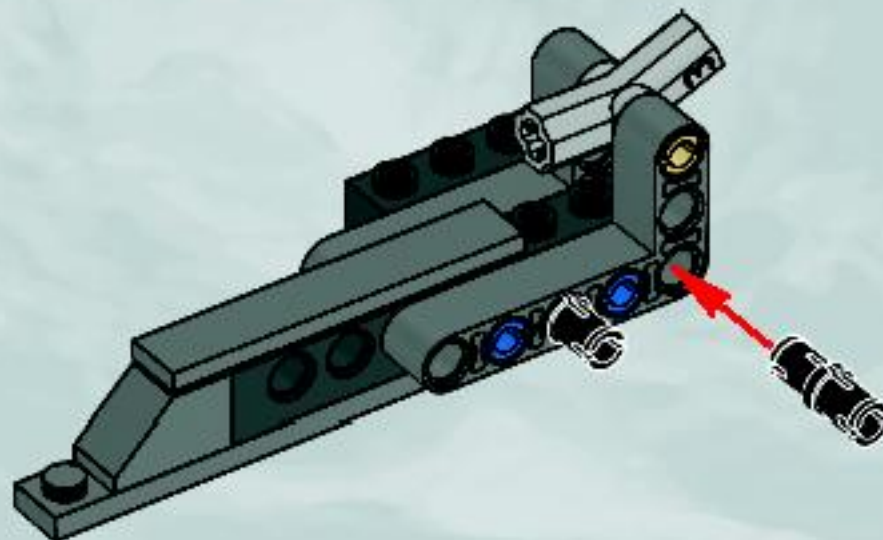



8

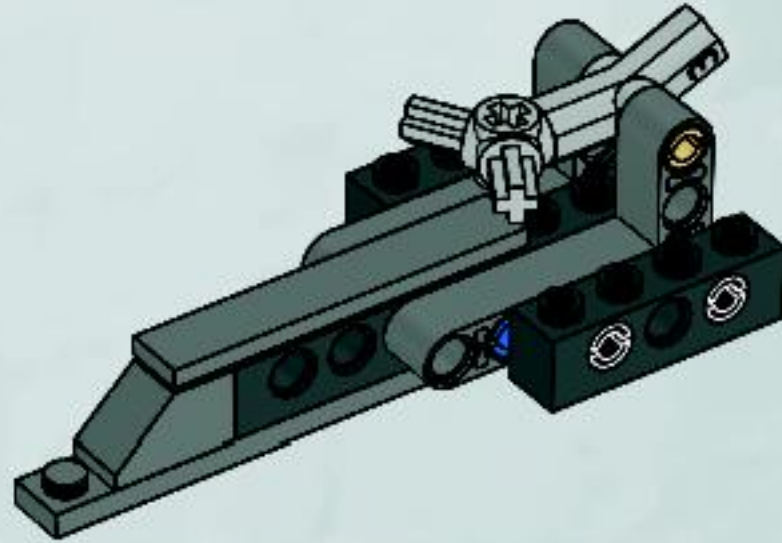

9

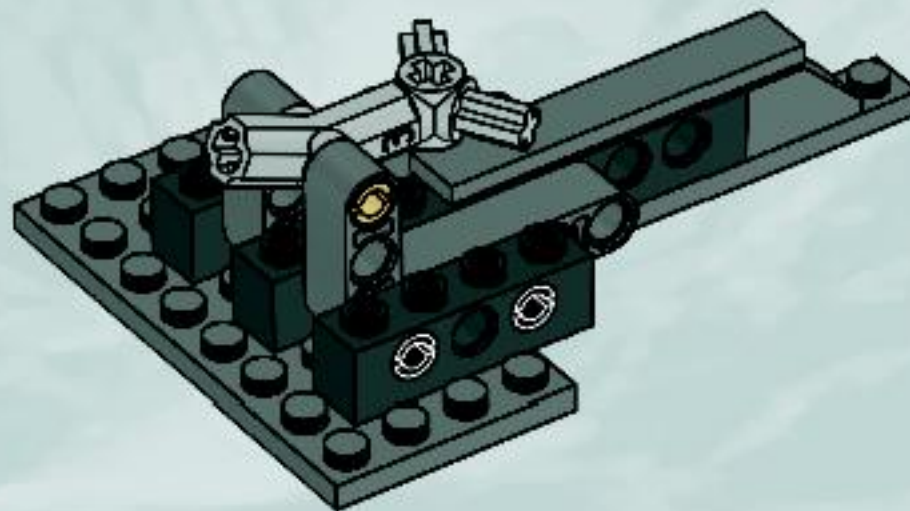

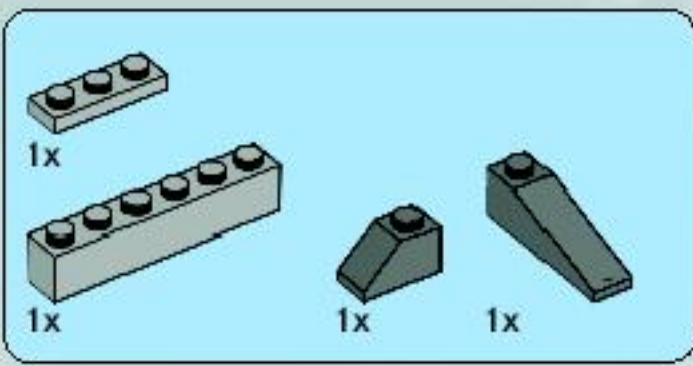

10

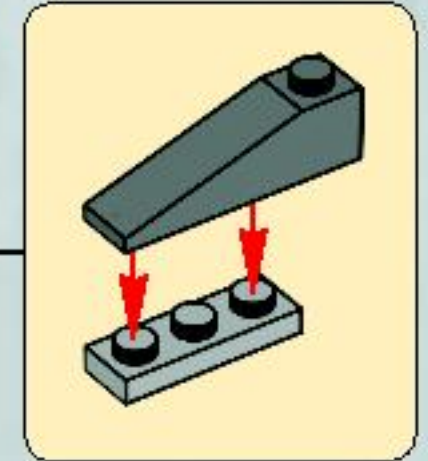
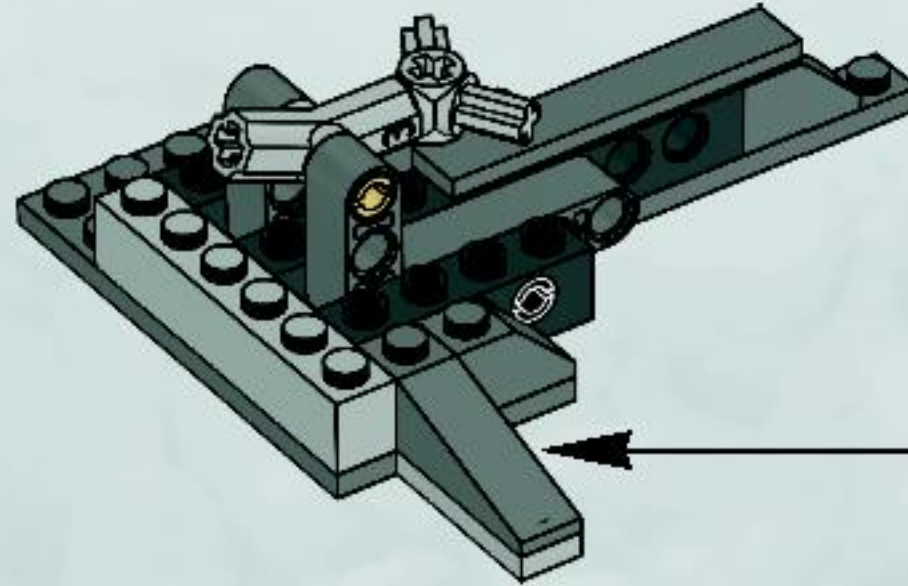

11

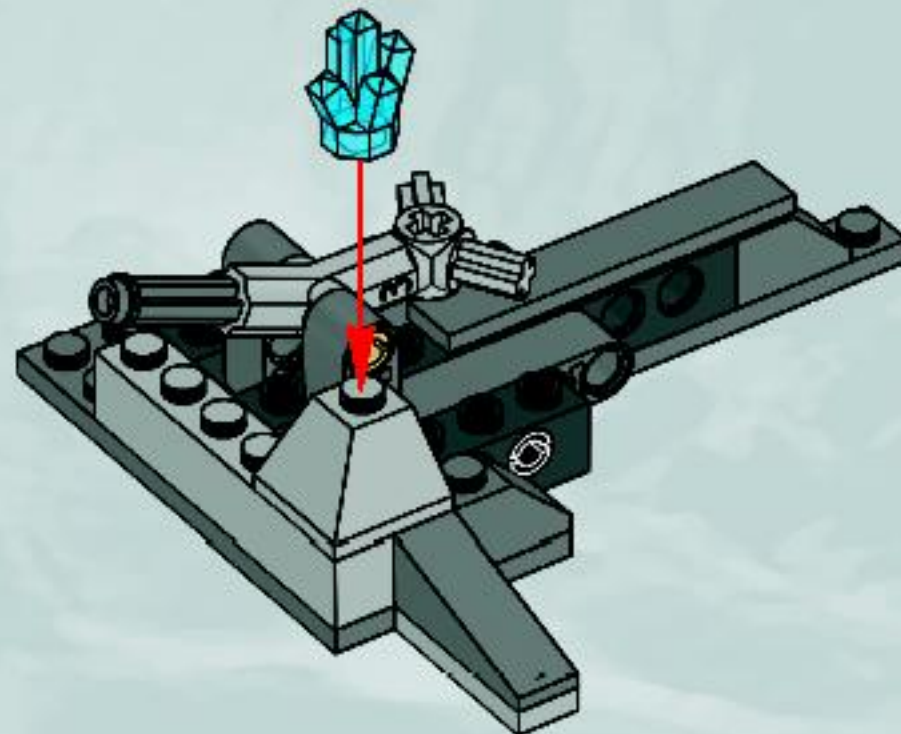

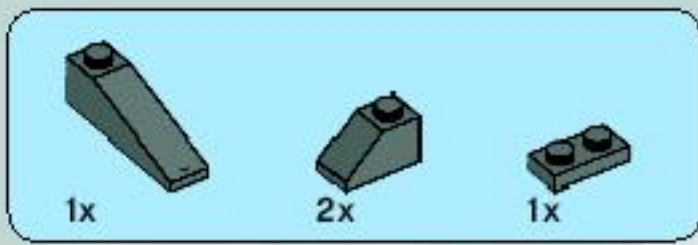

12

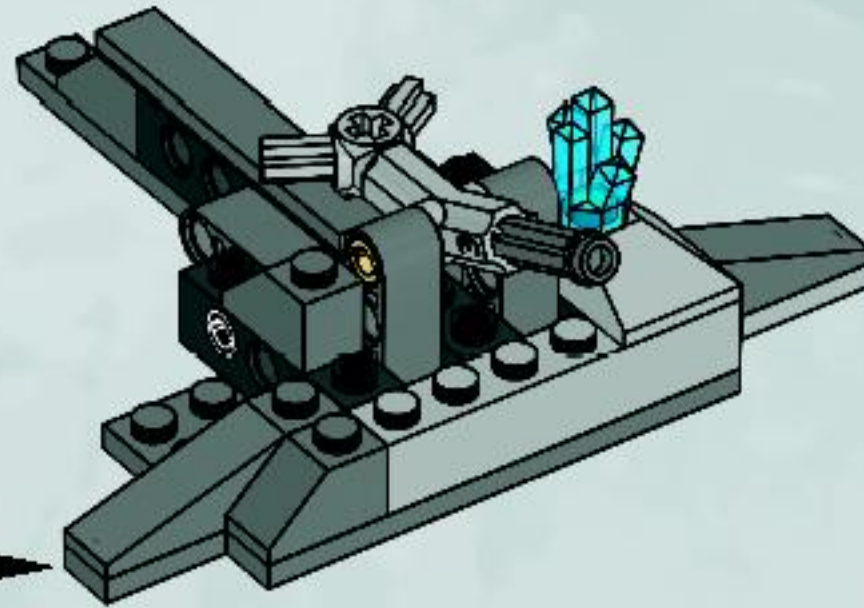
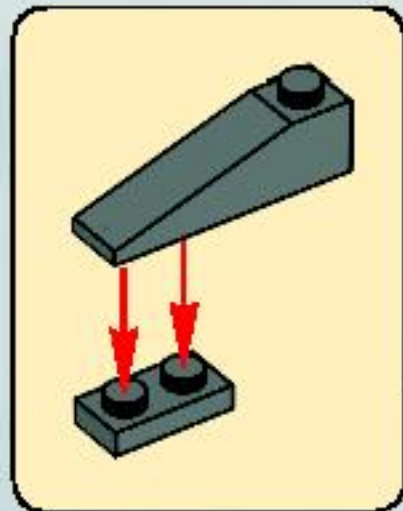

13

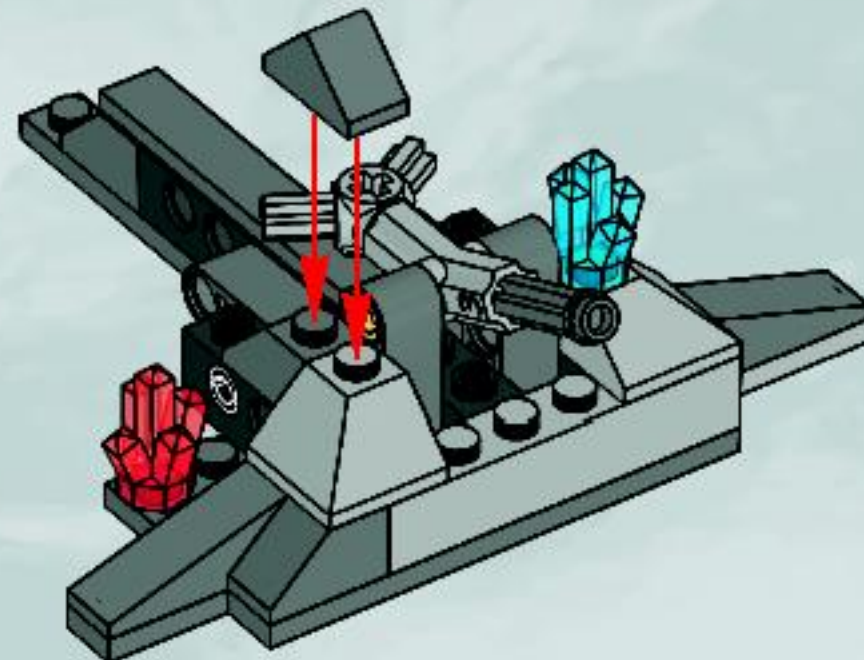

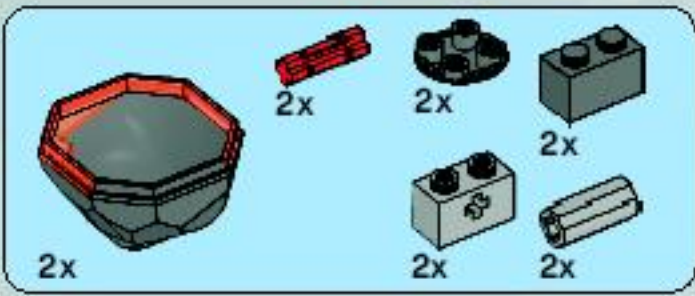

14

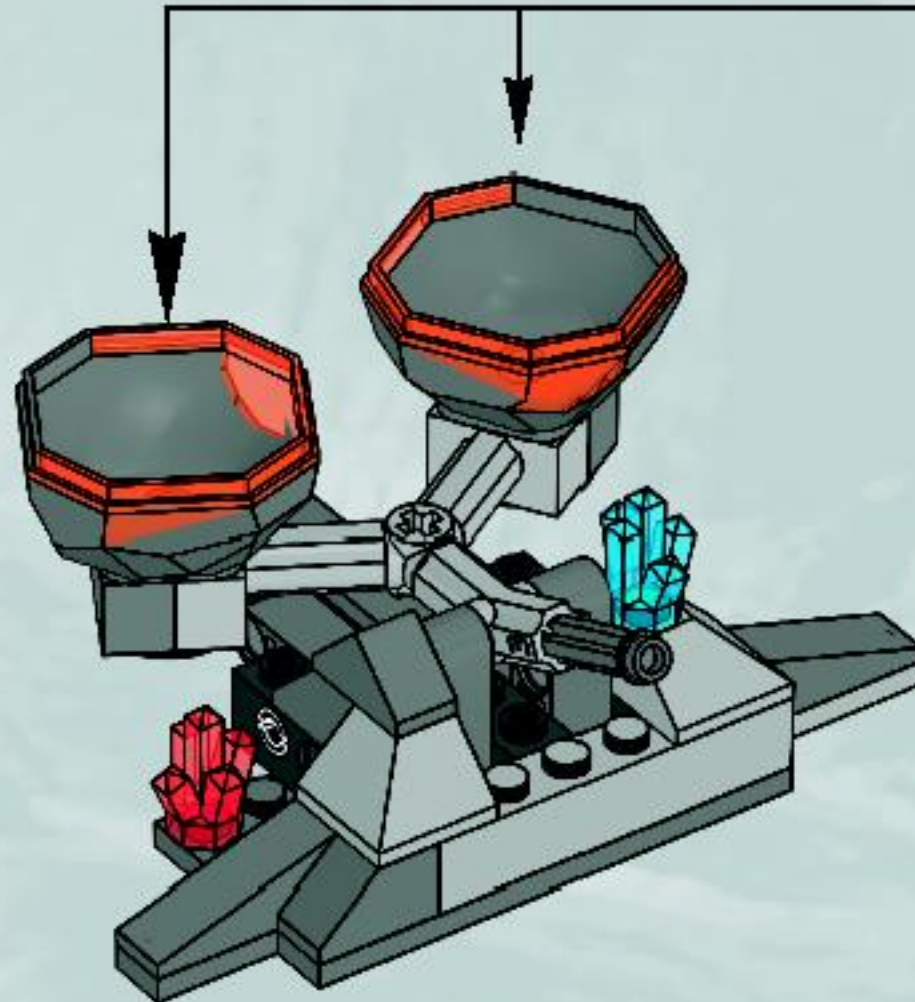
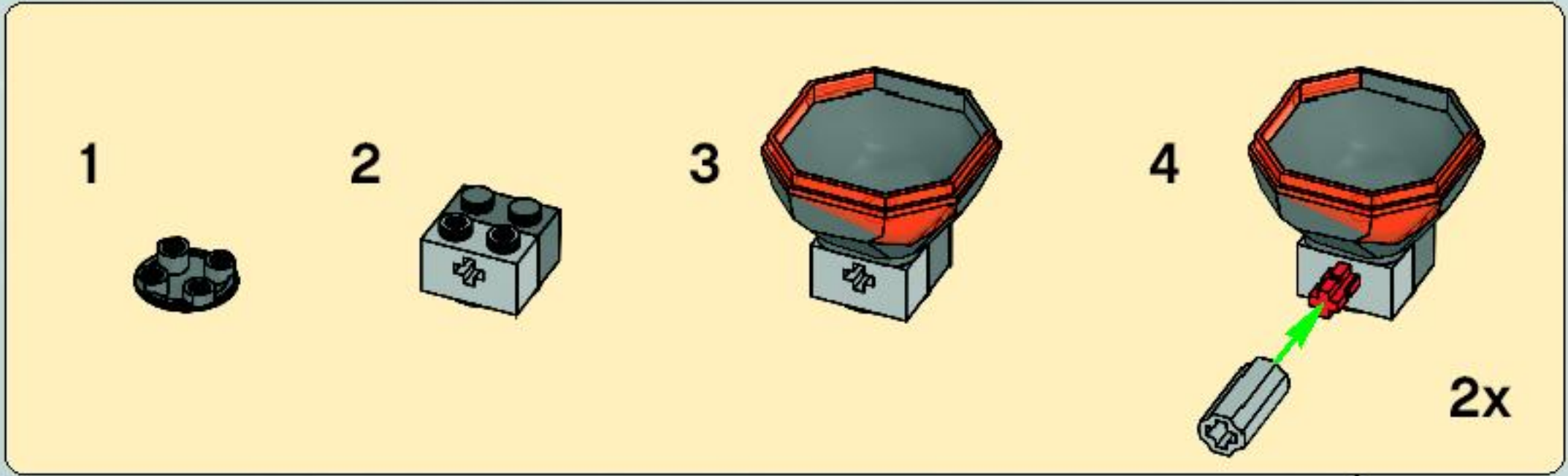

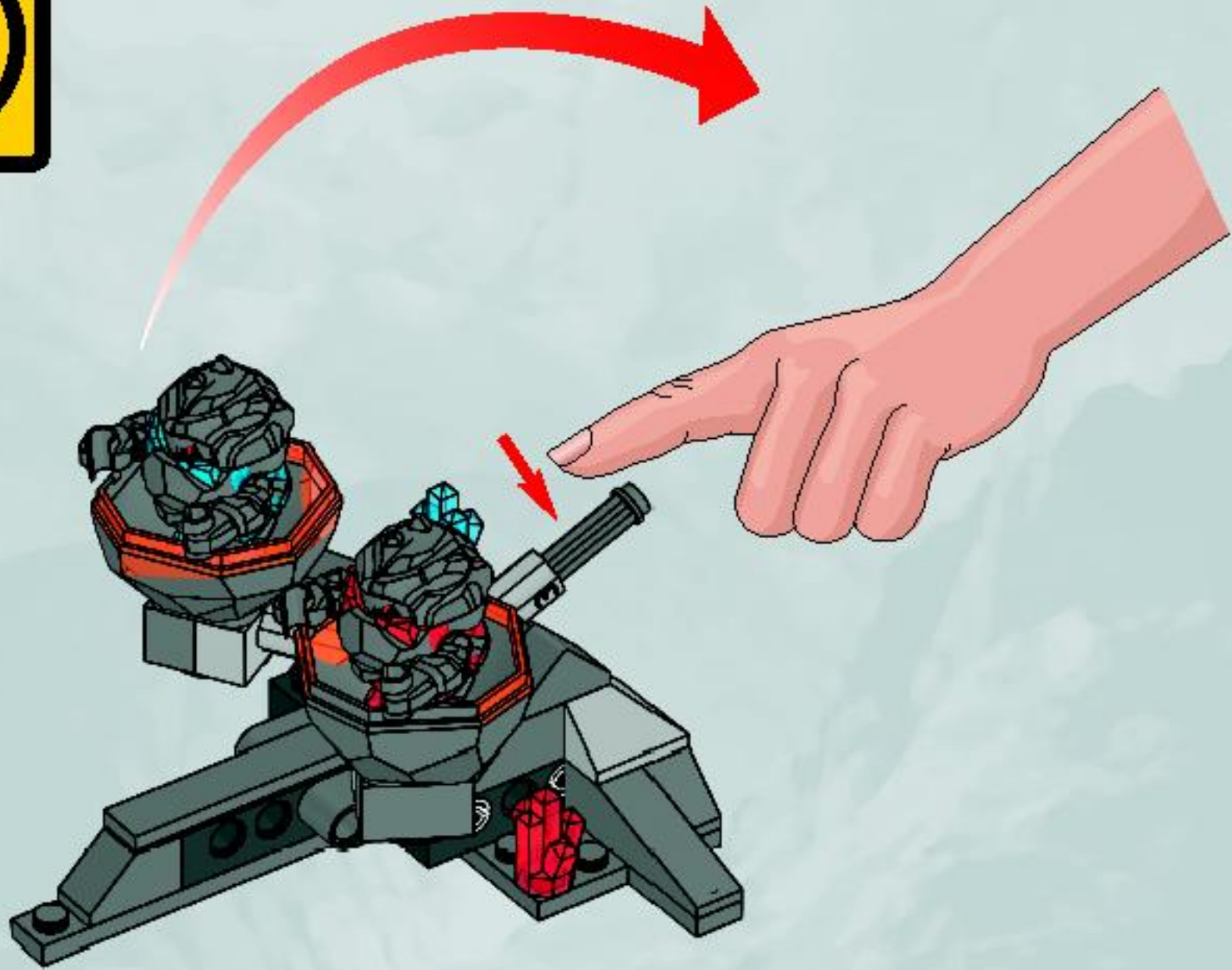

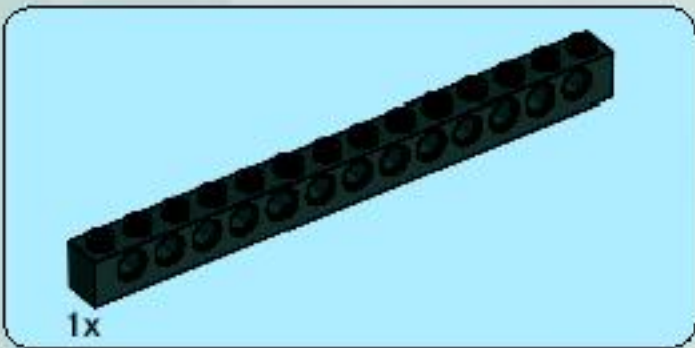
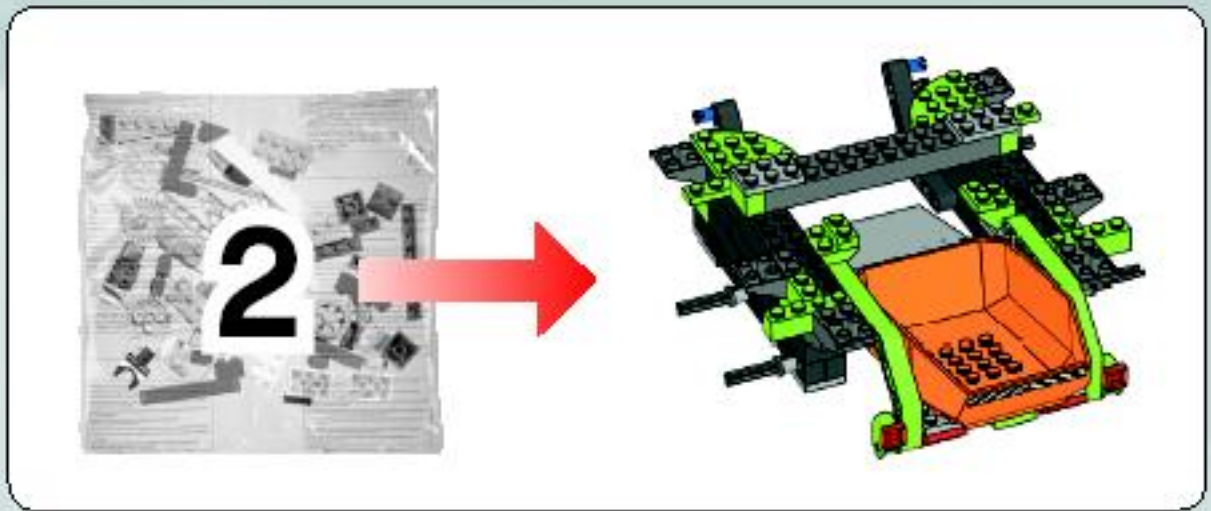
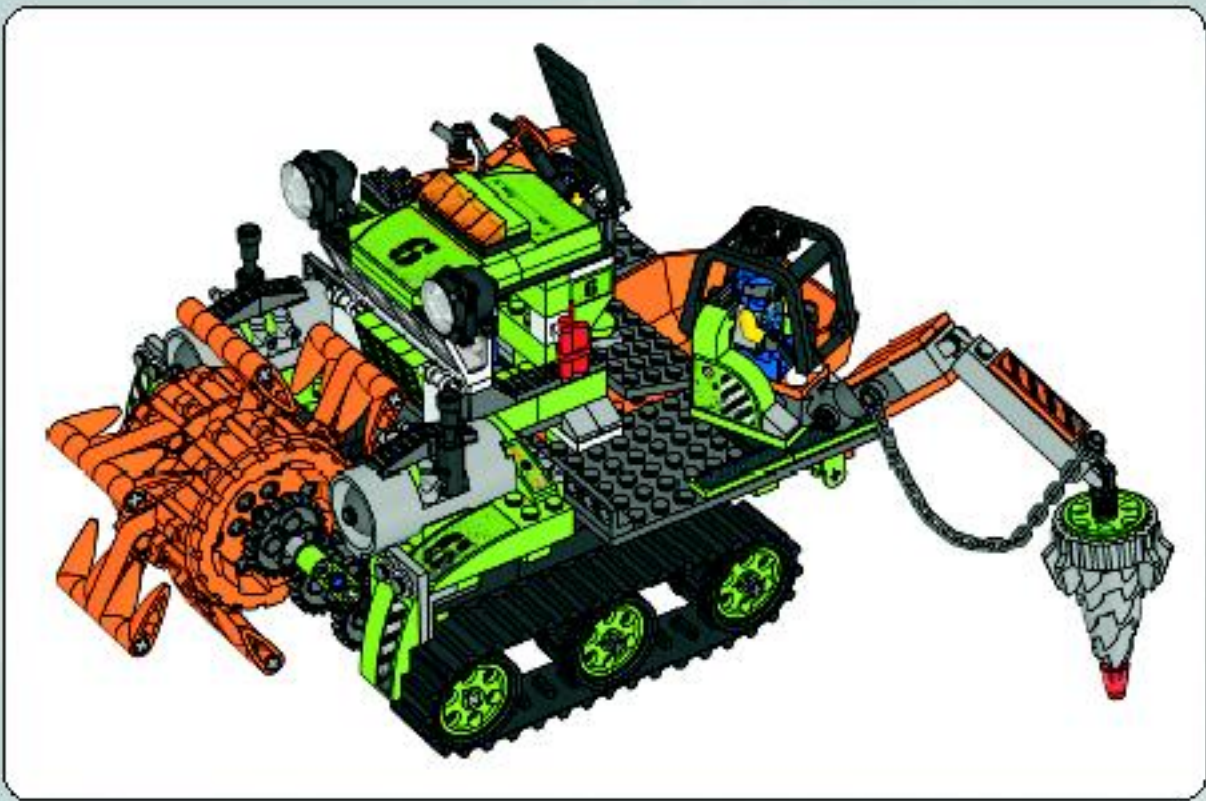

1

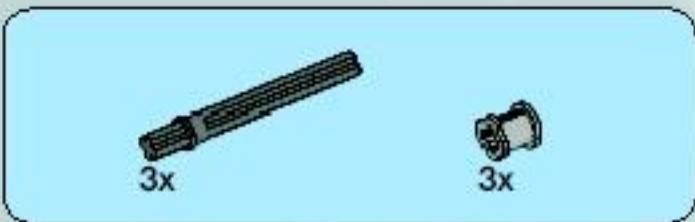

2

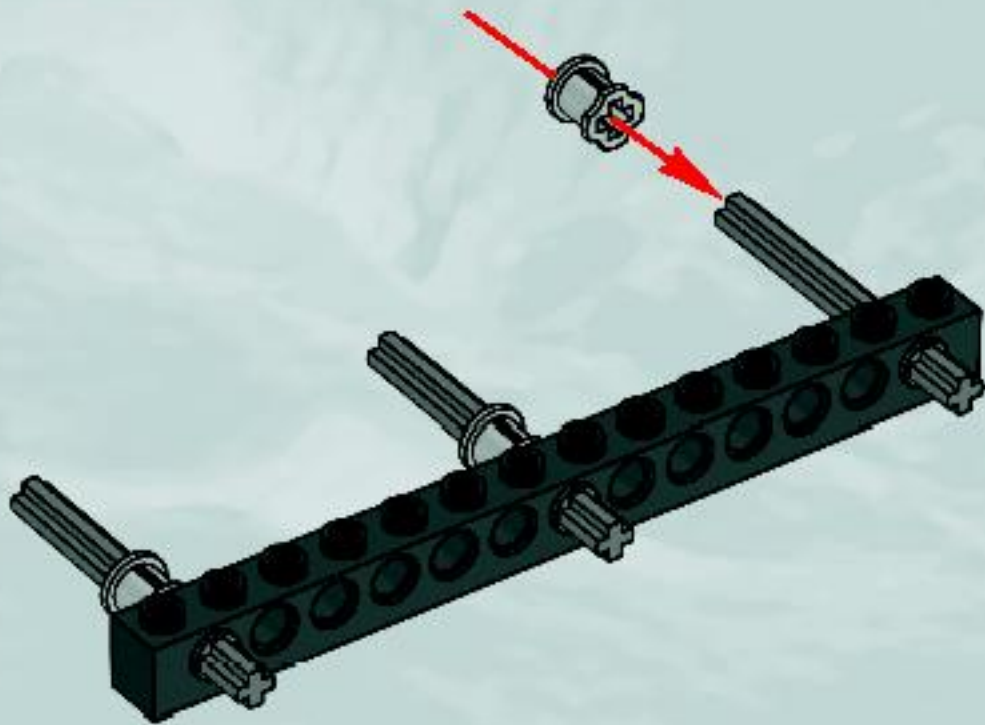

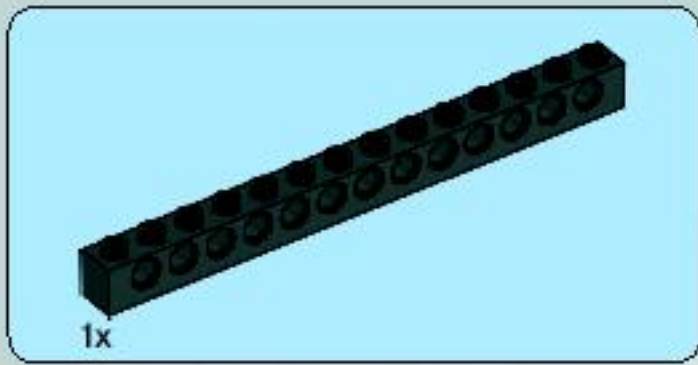

3

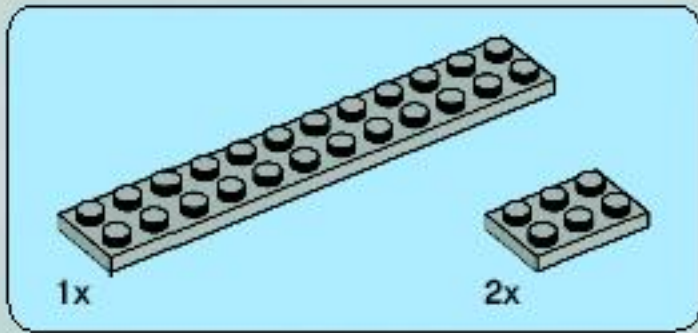
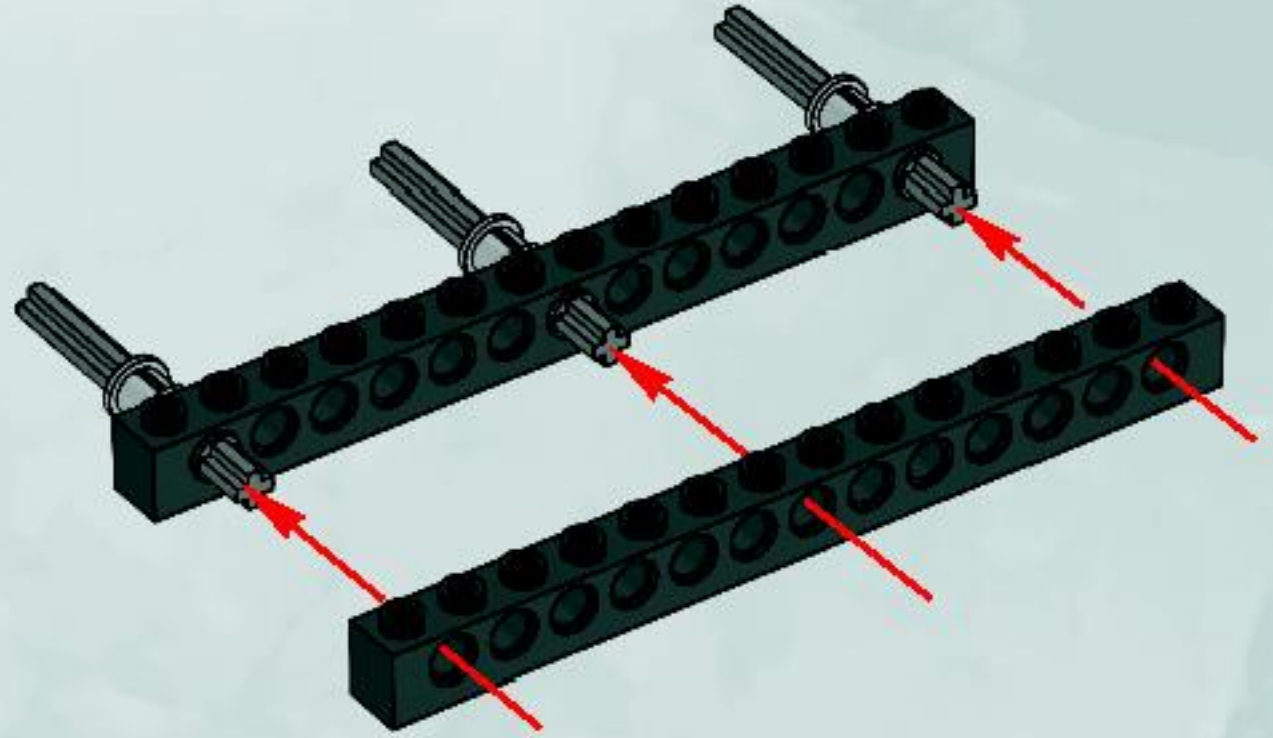

4

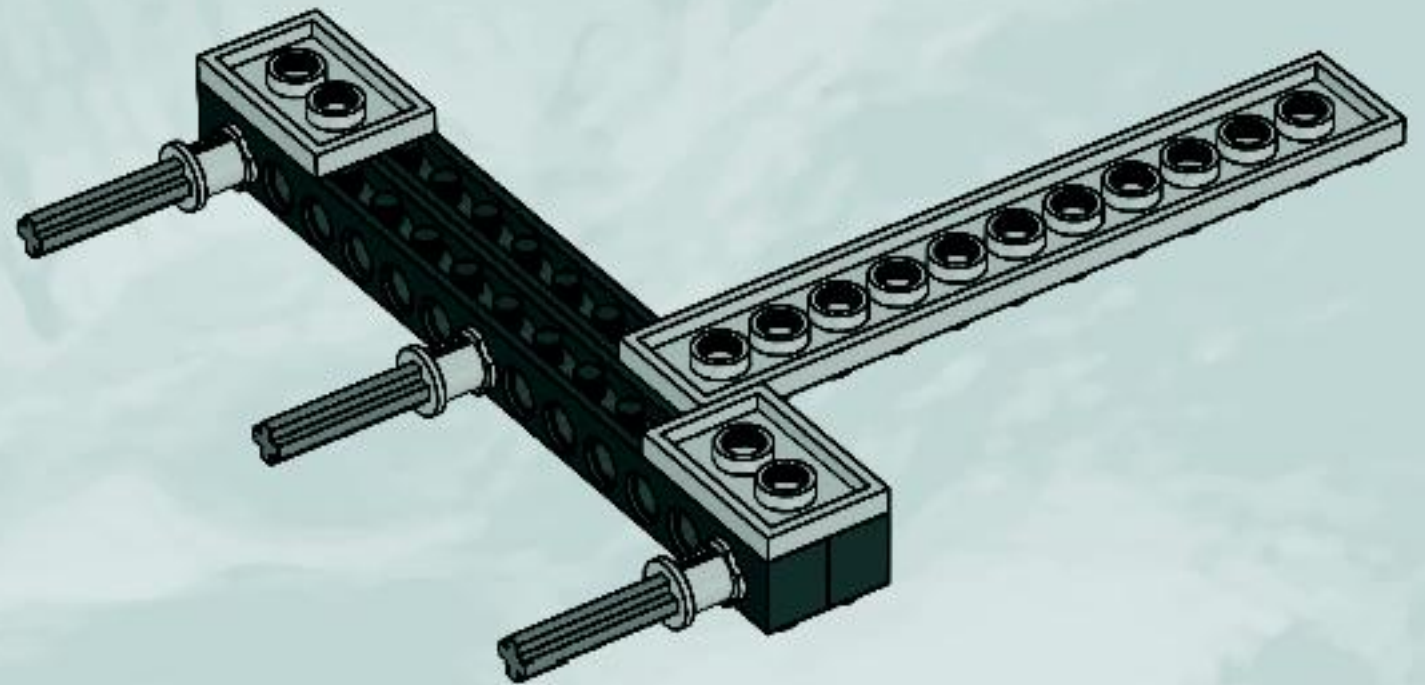

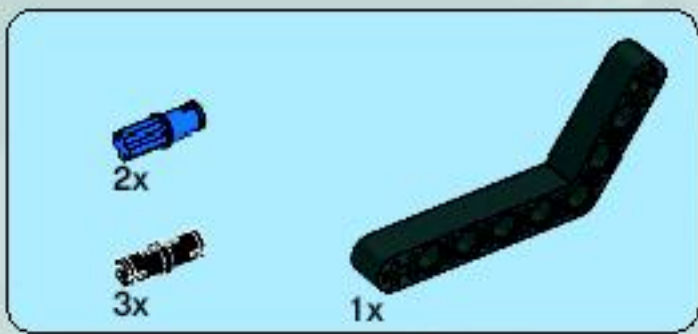

5

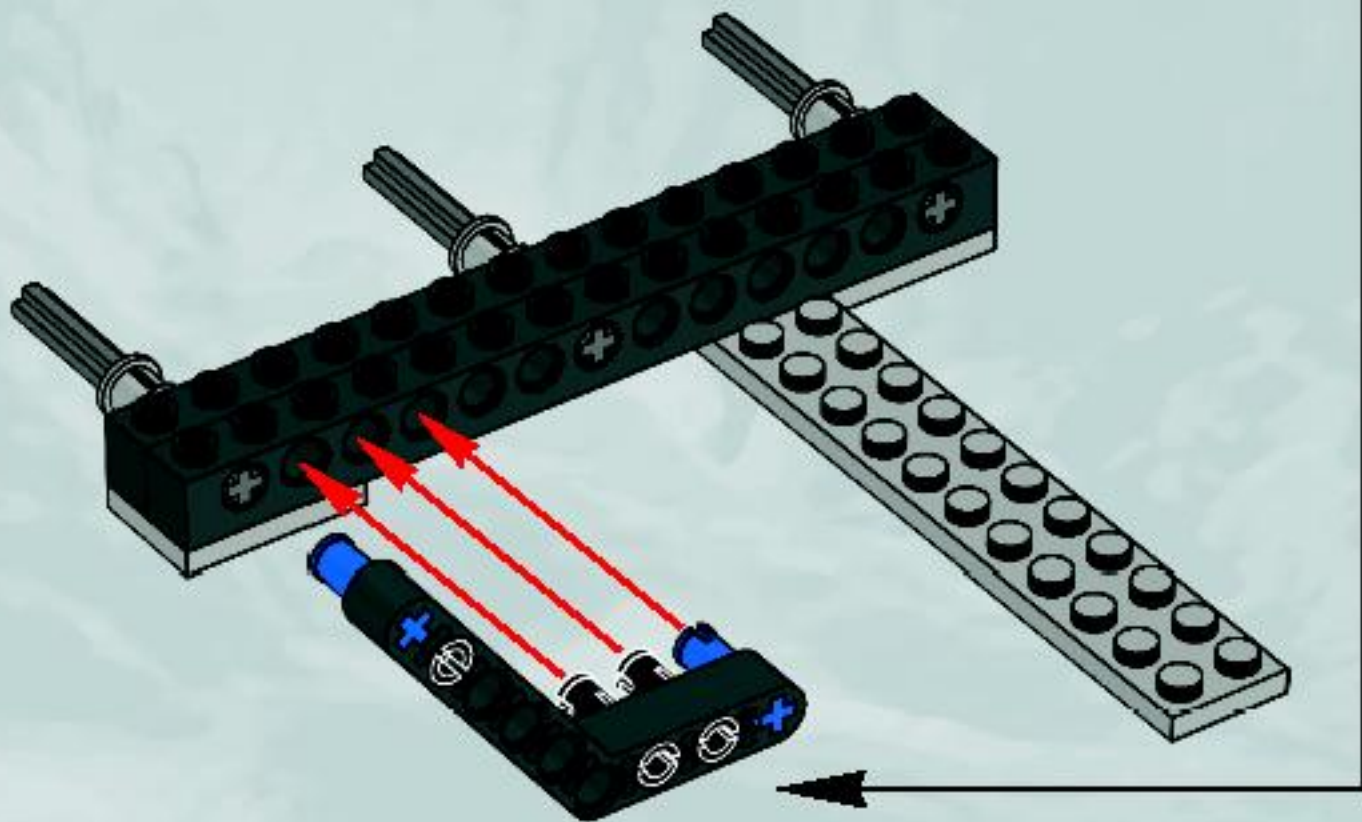
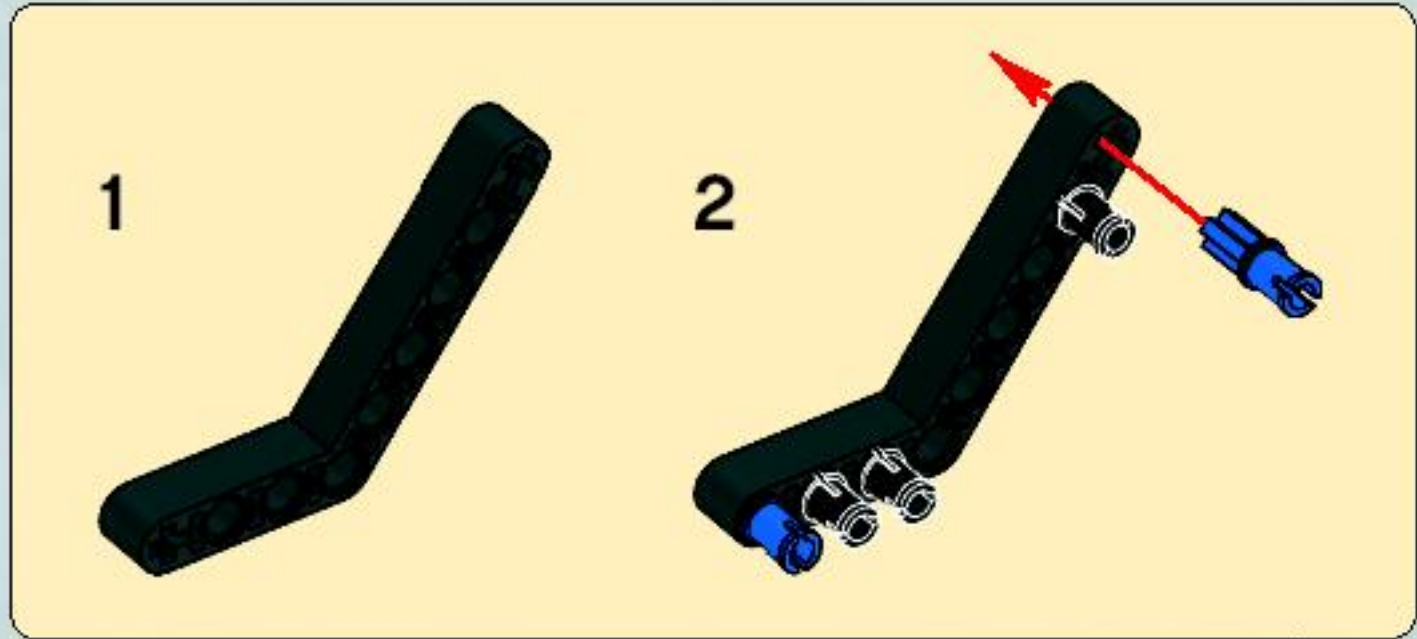



6

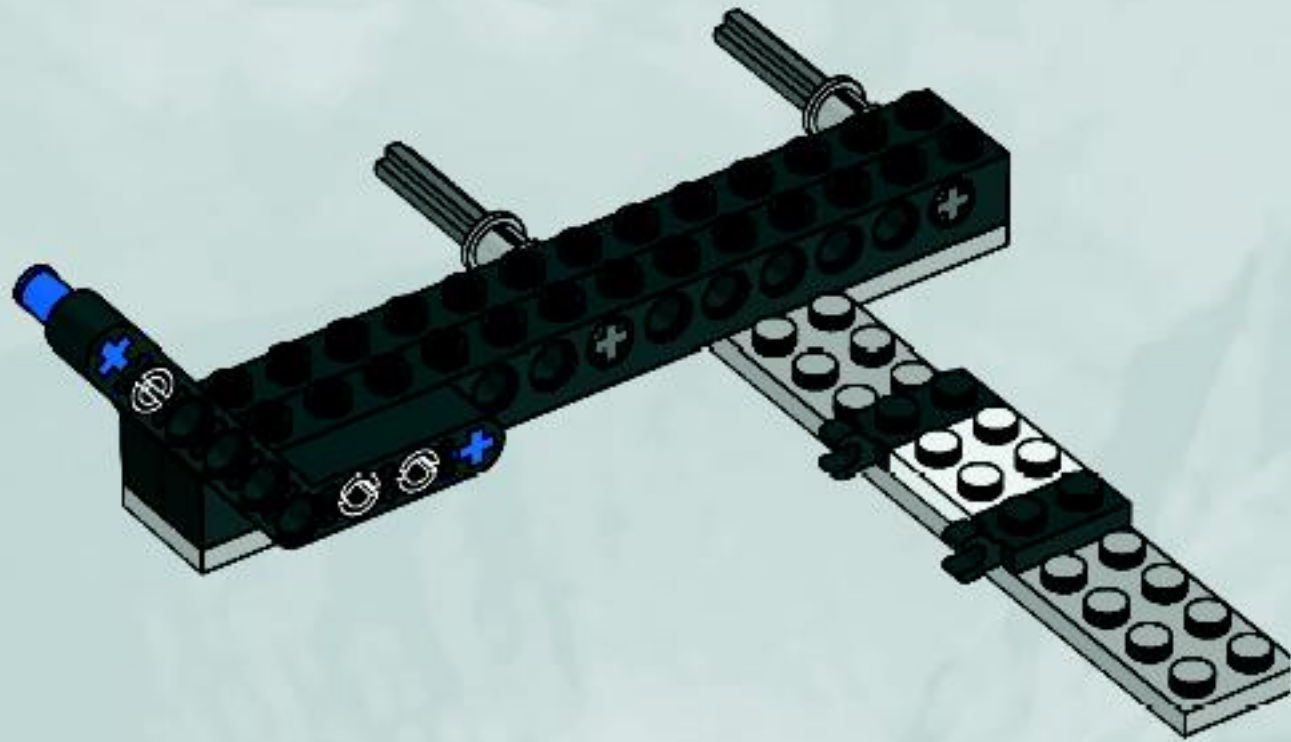

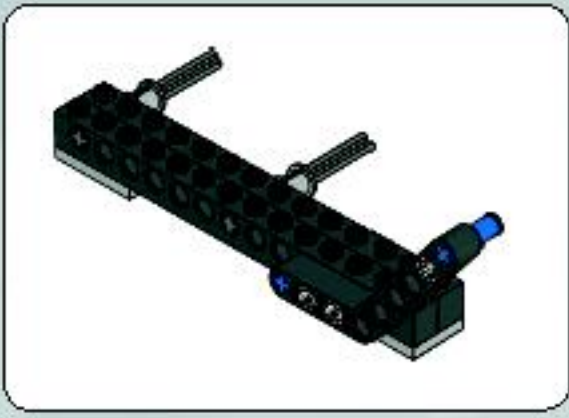

1

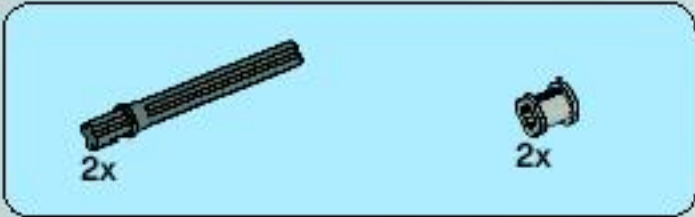

2

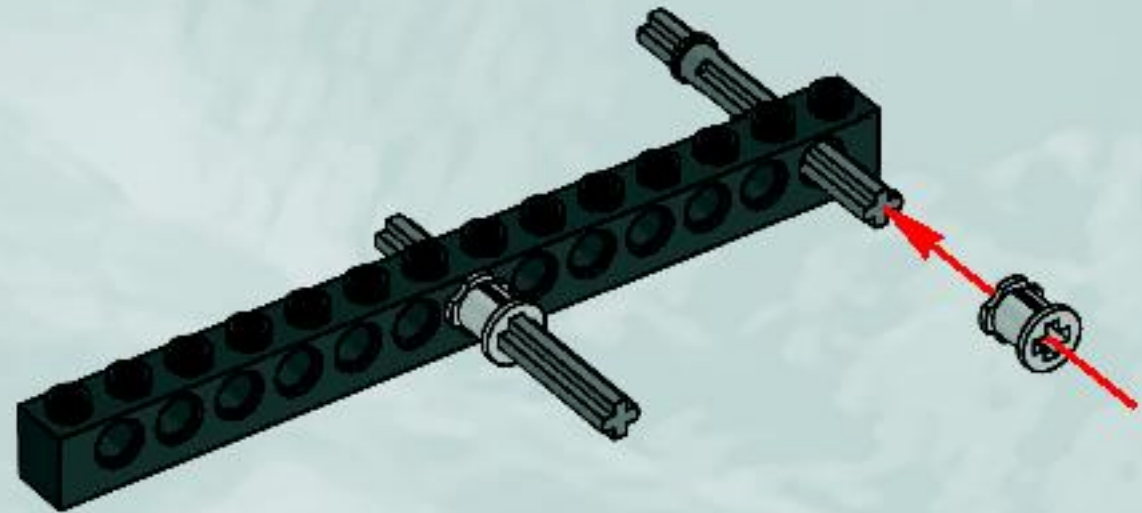

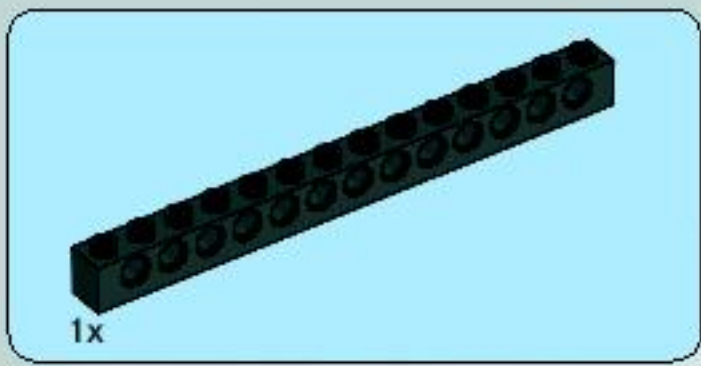

3

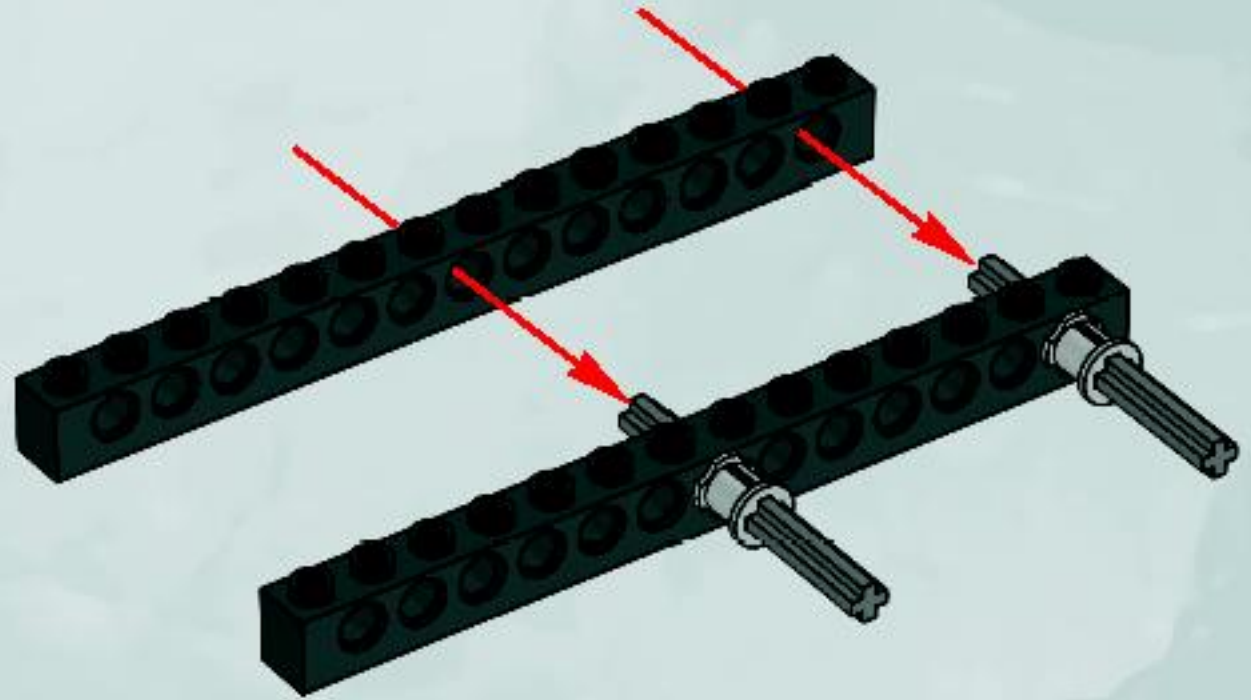

4

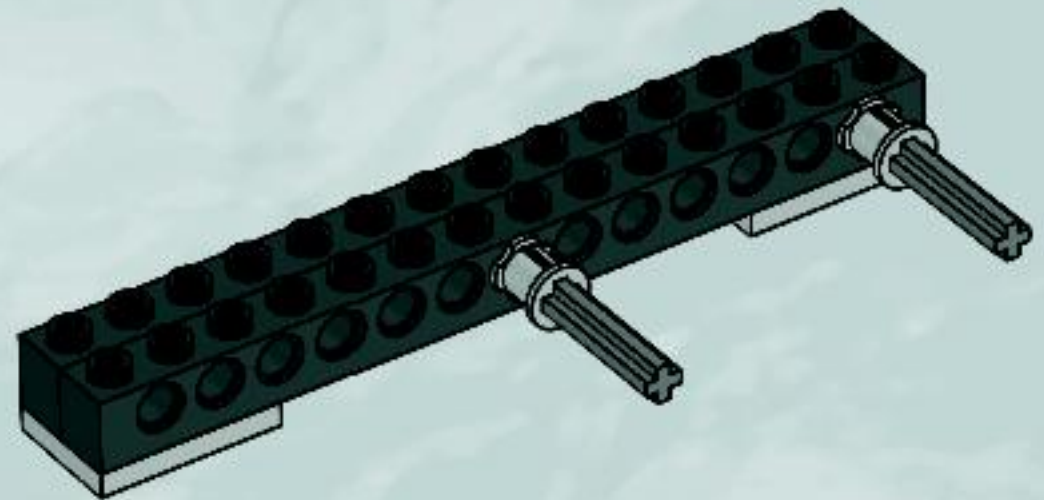

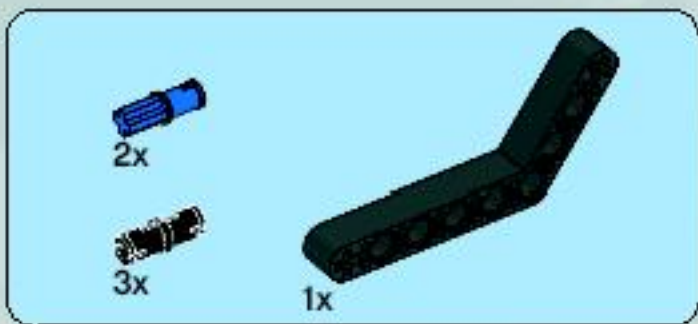

5

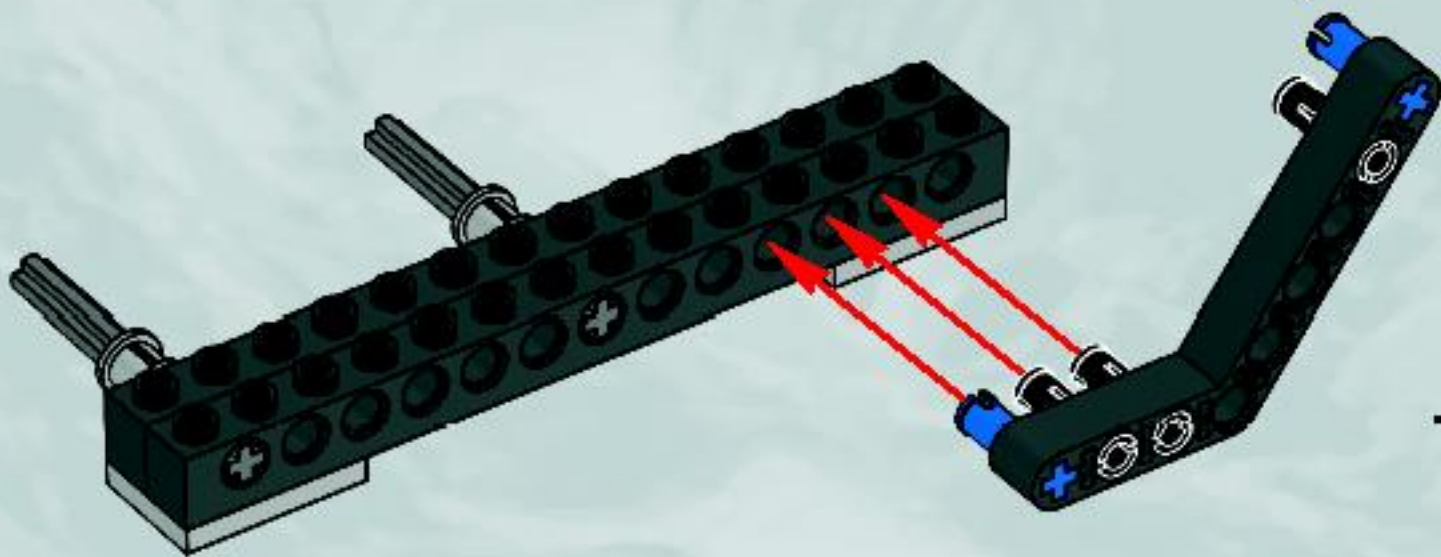
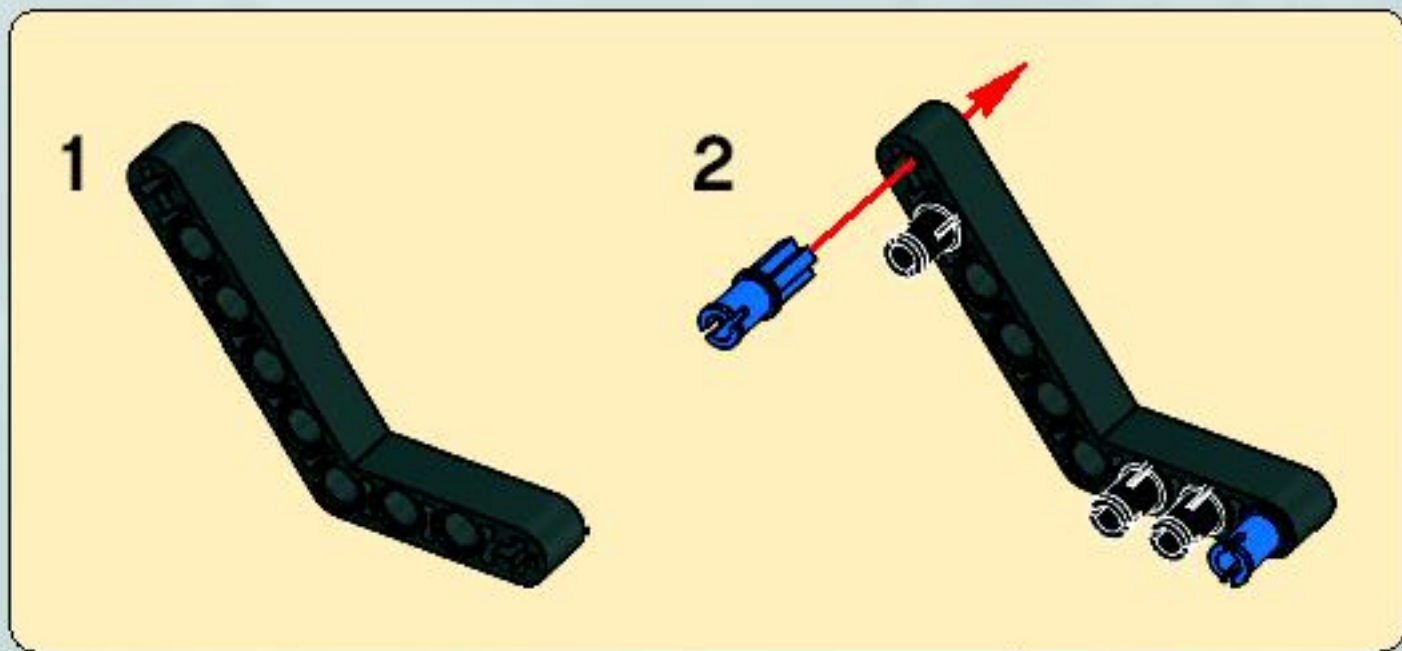

7

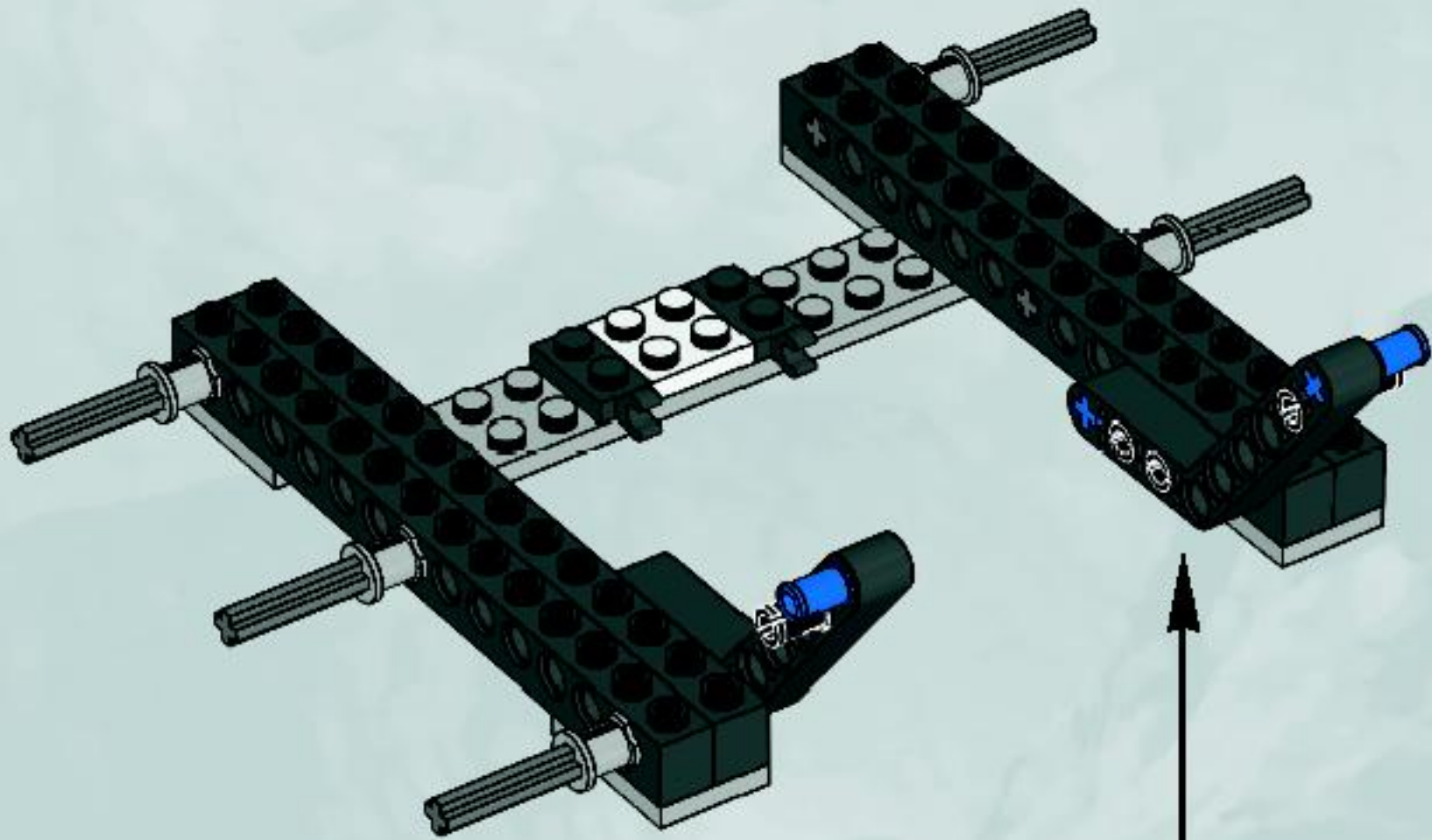

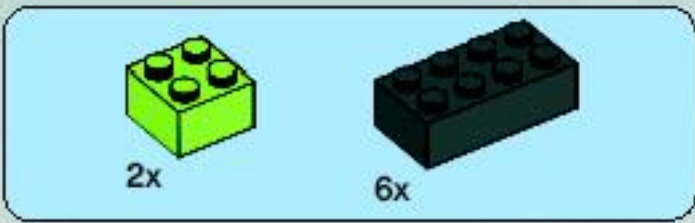

8

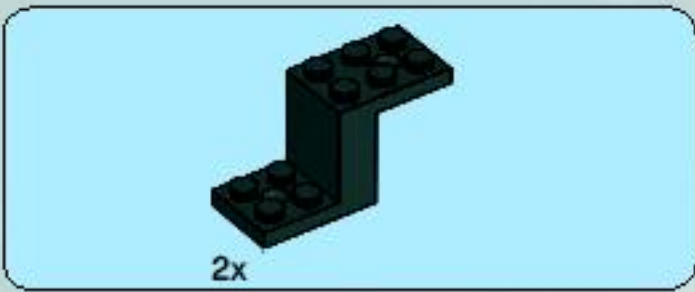
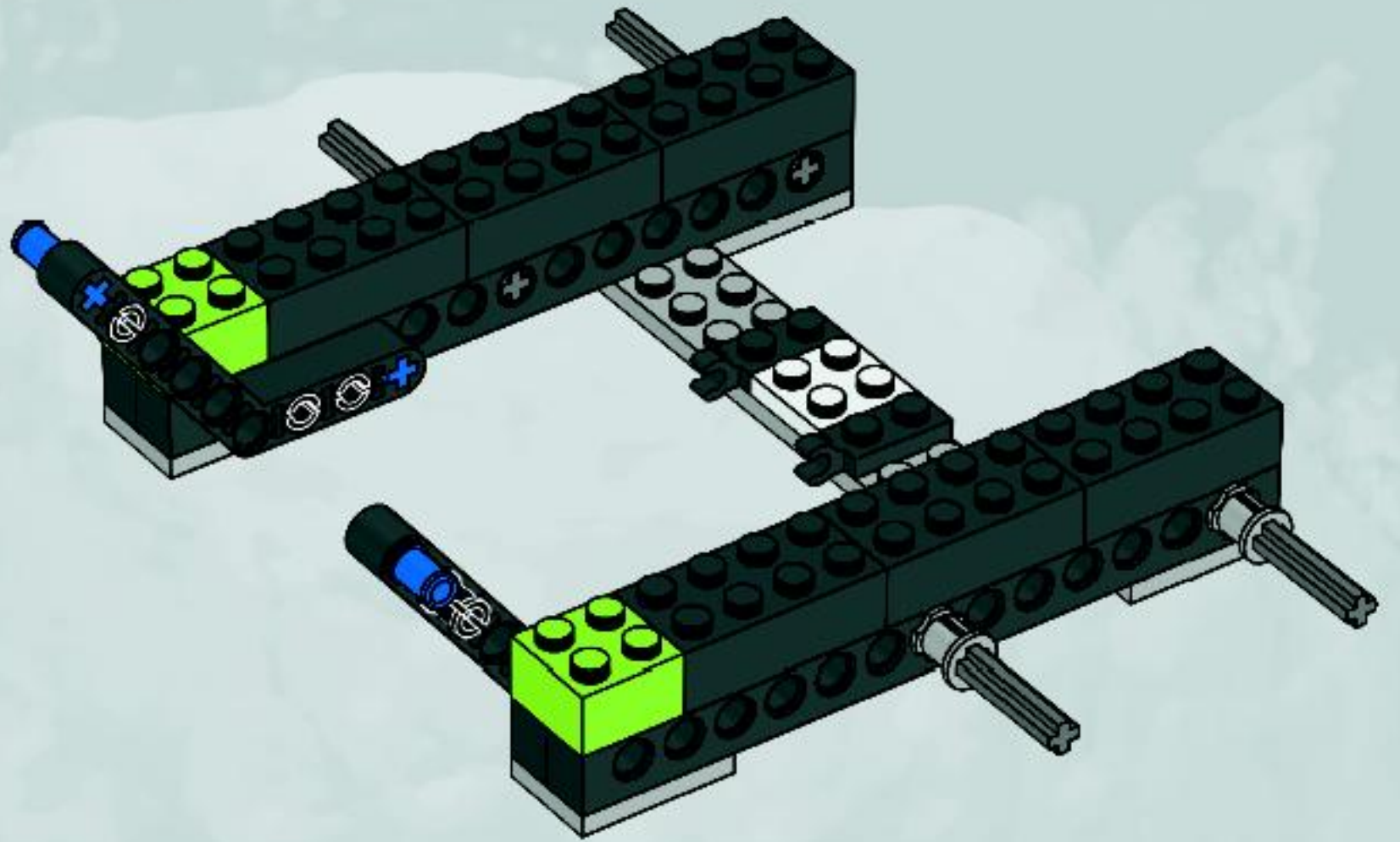

9

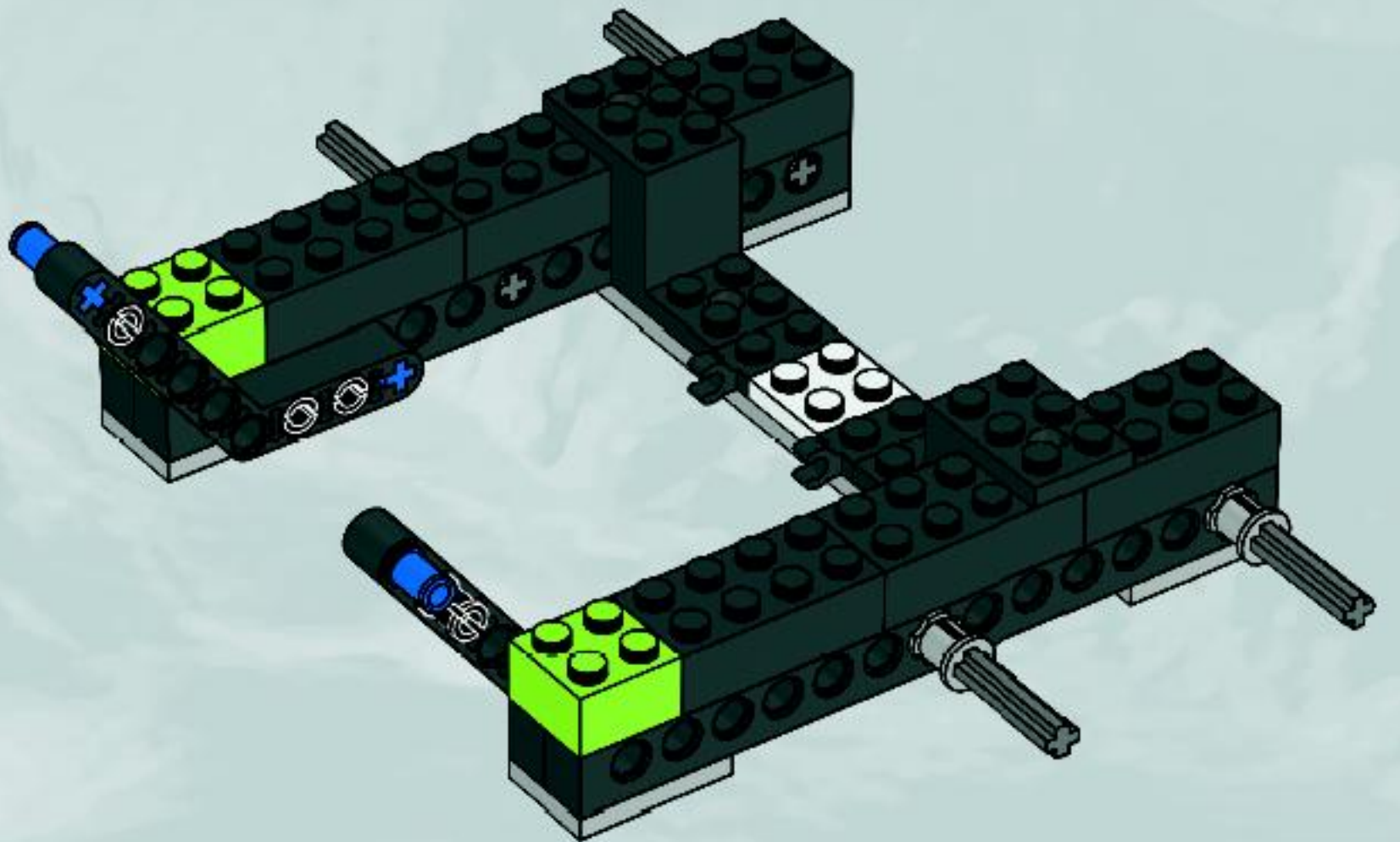

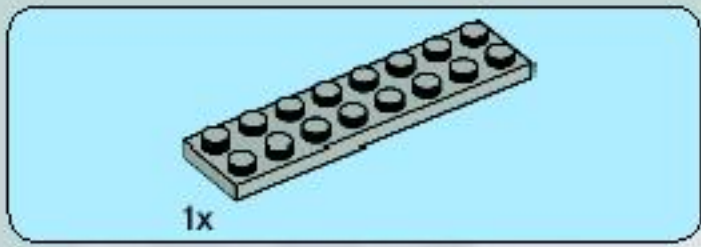

10

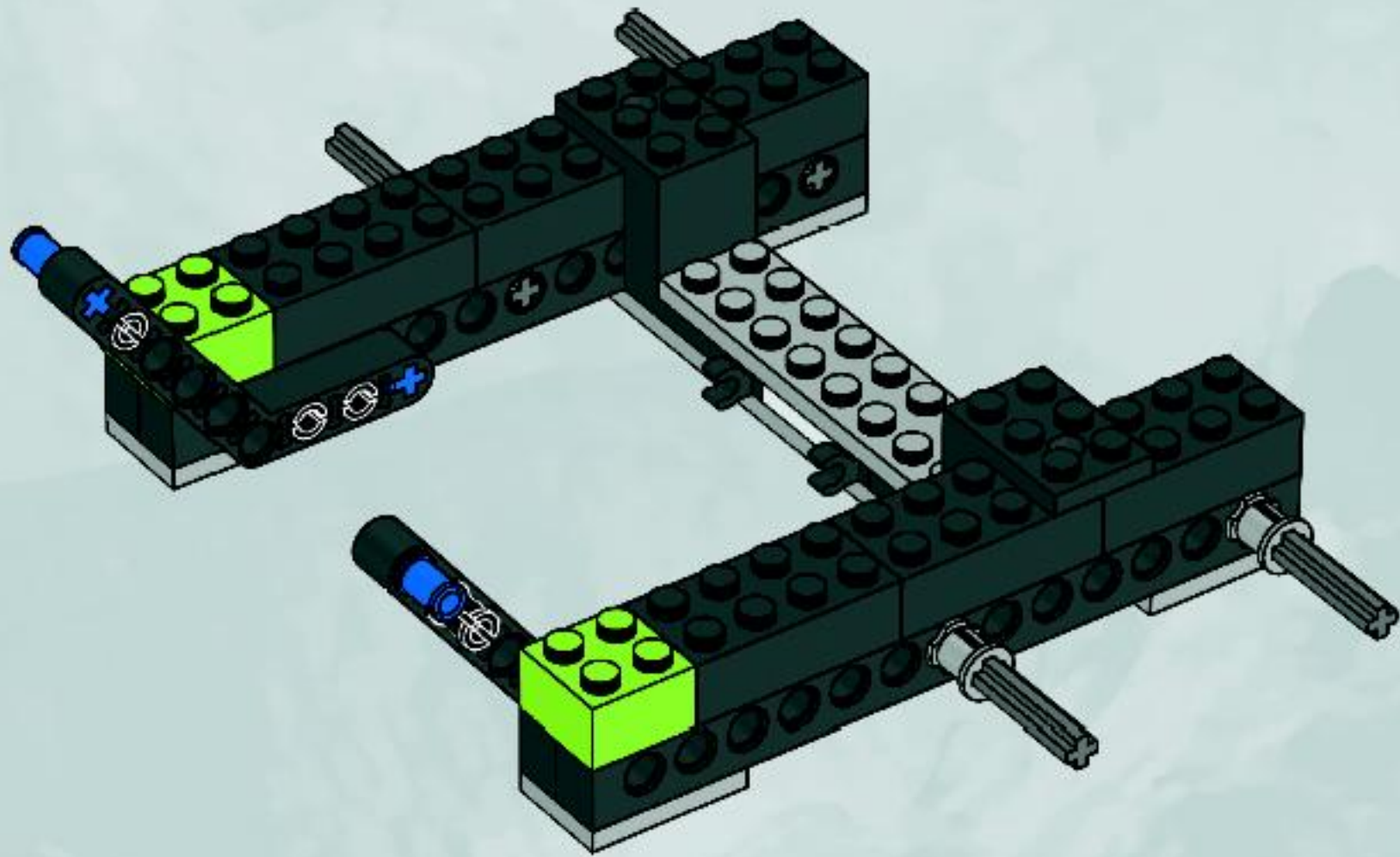



2x

11

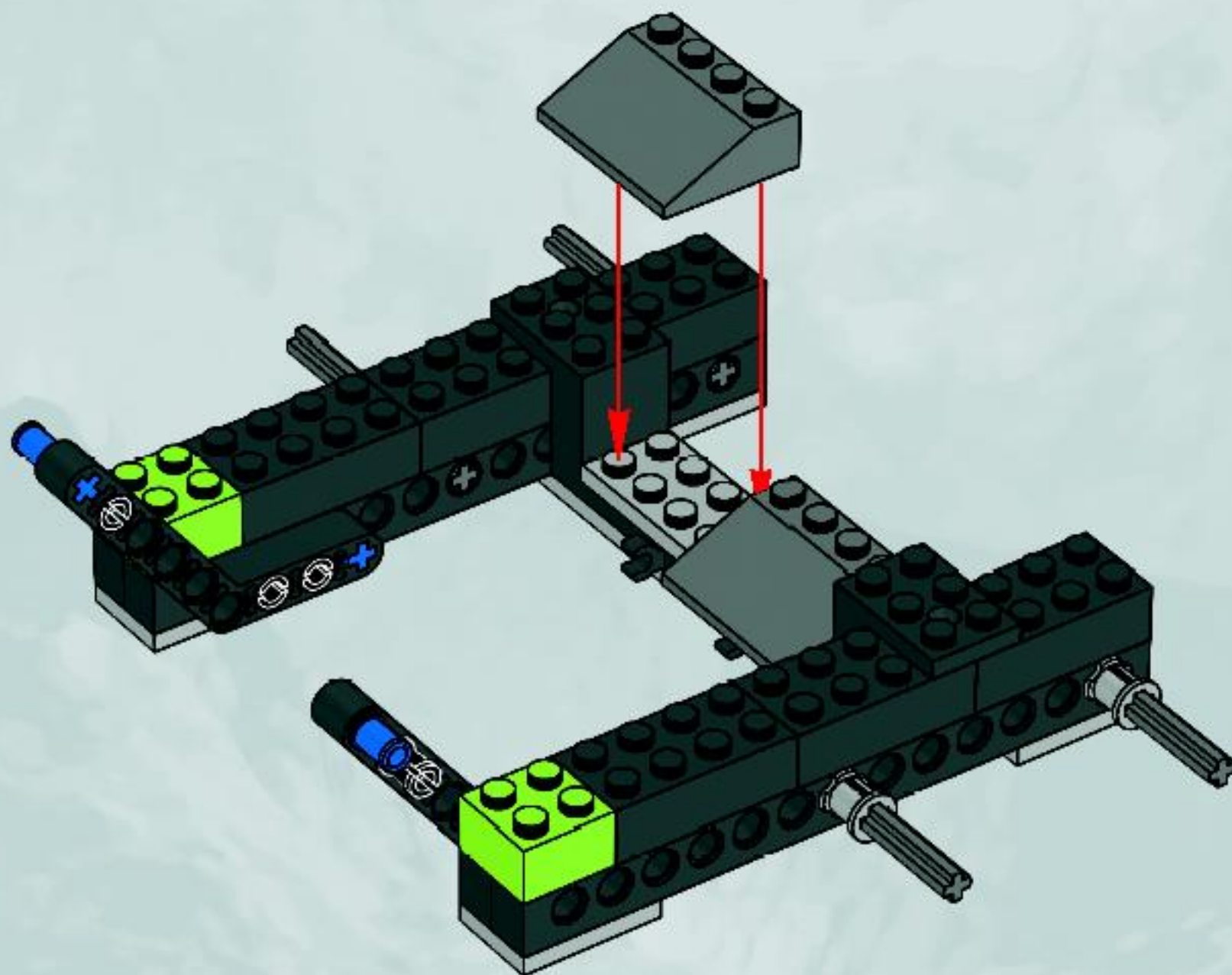

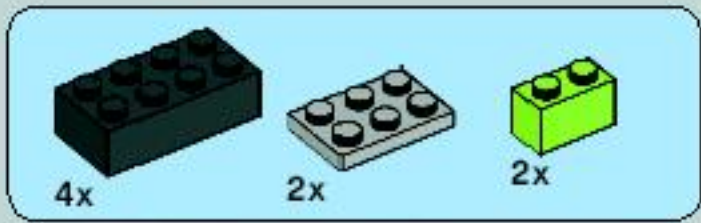

12

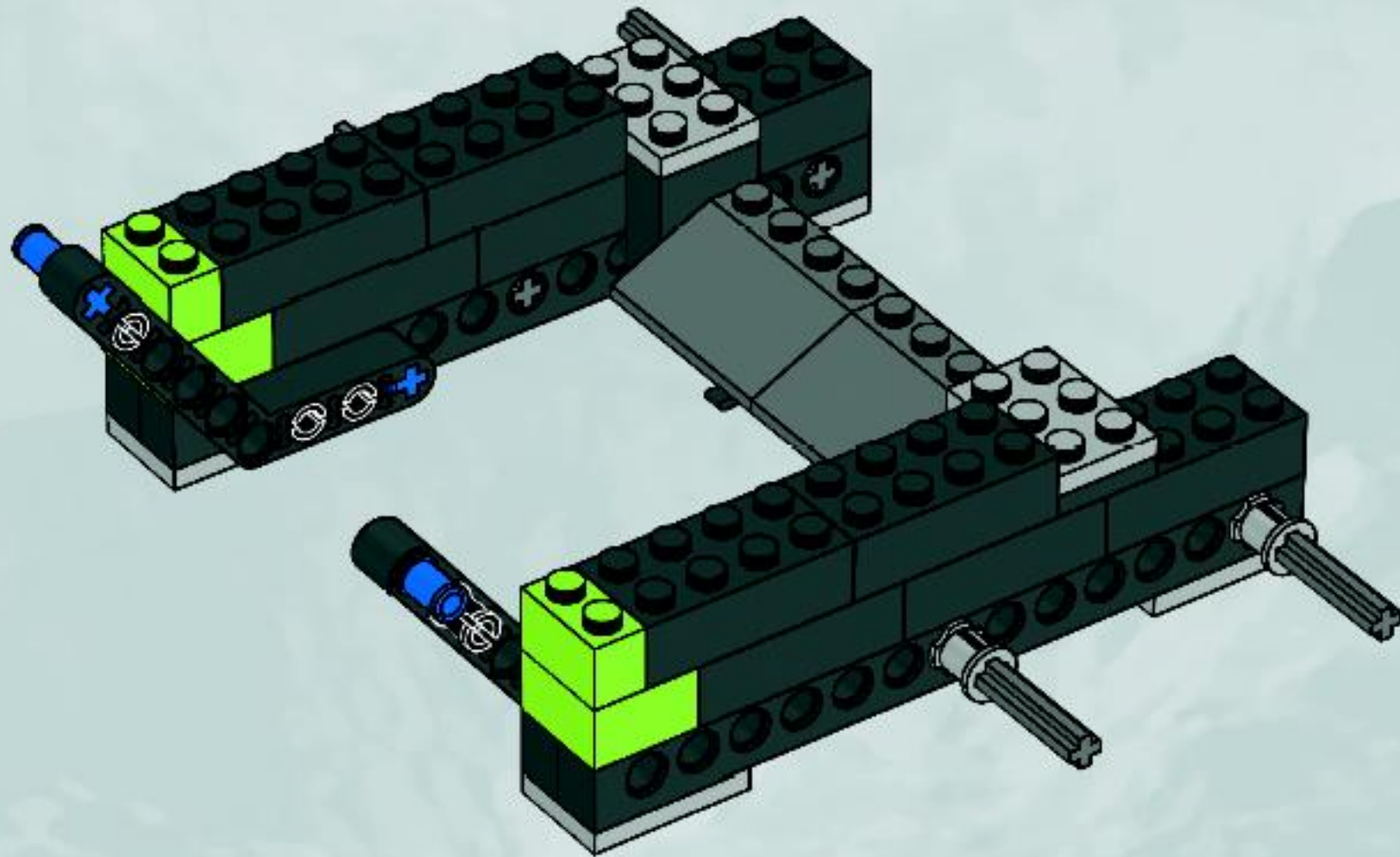



13

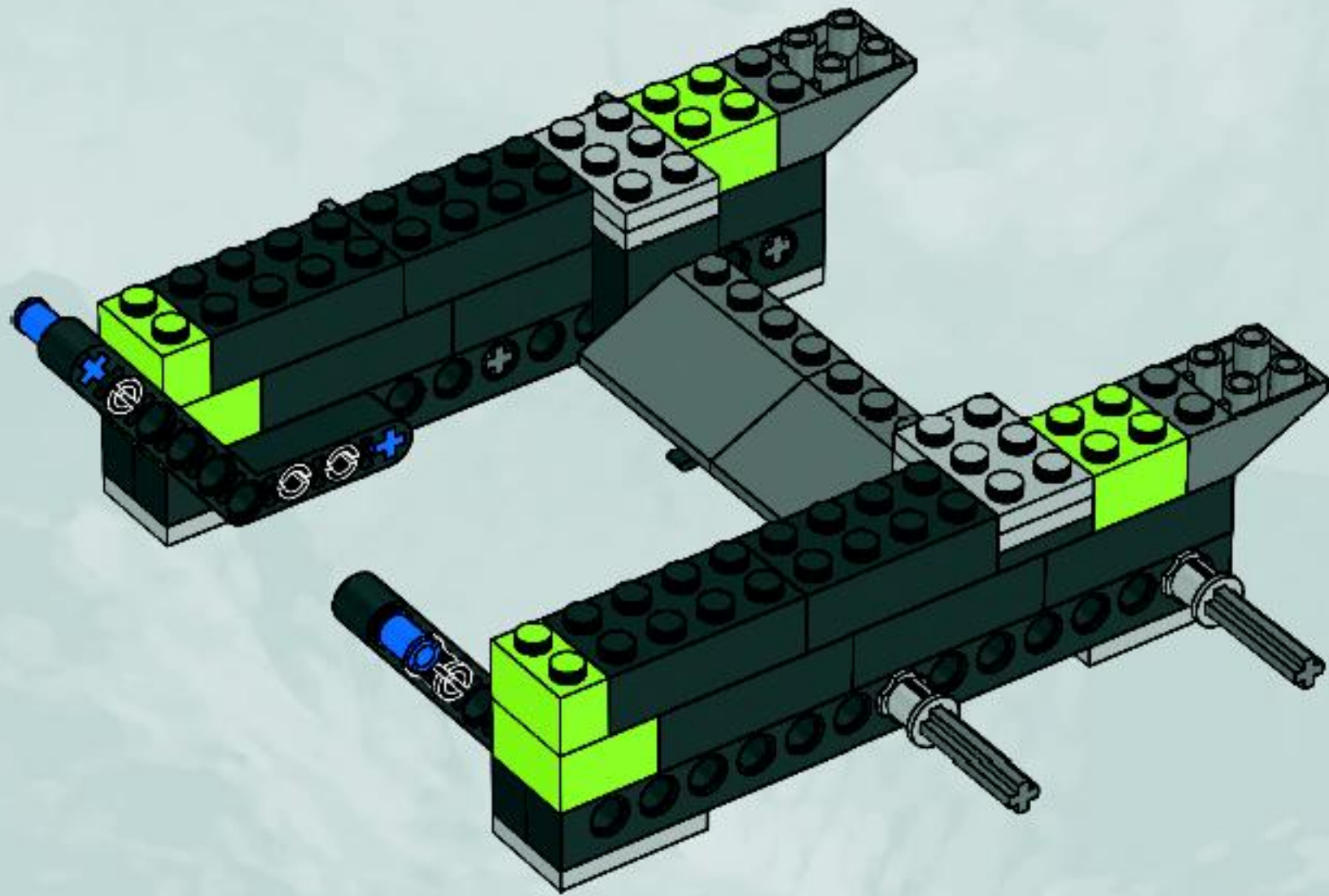

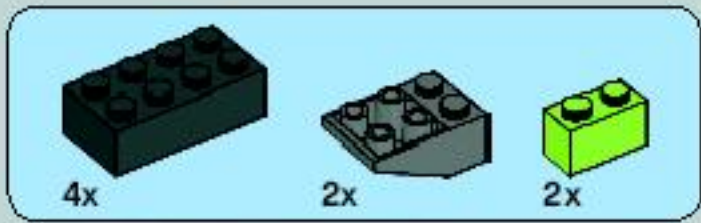

14

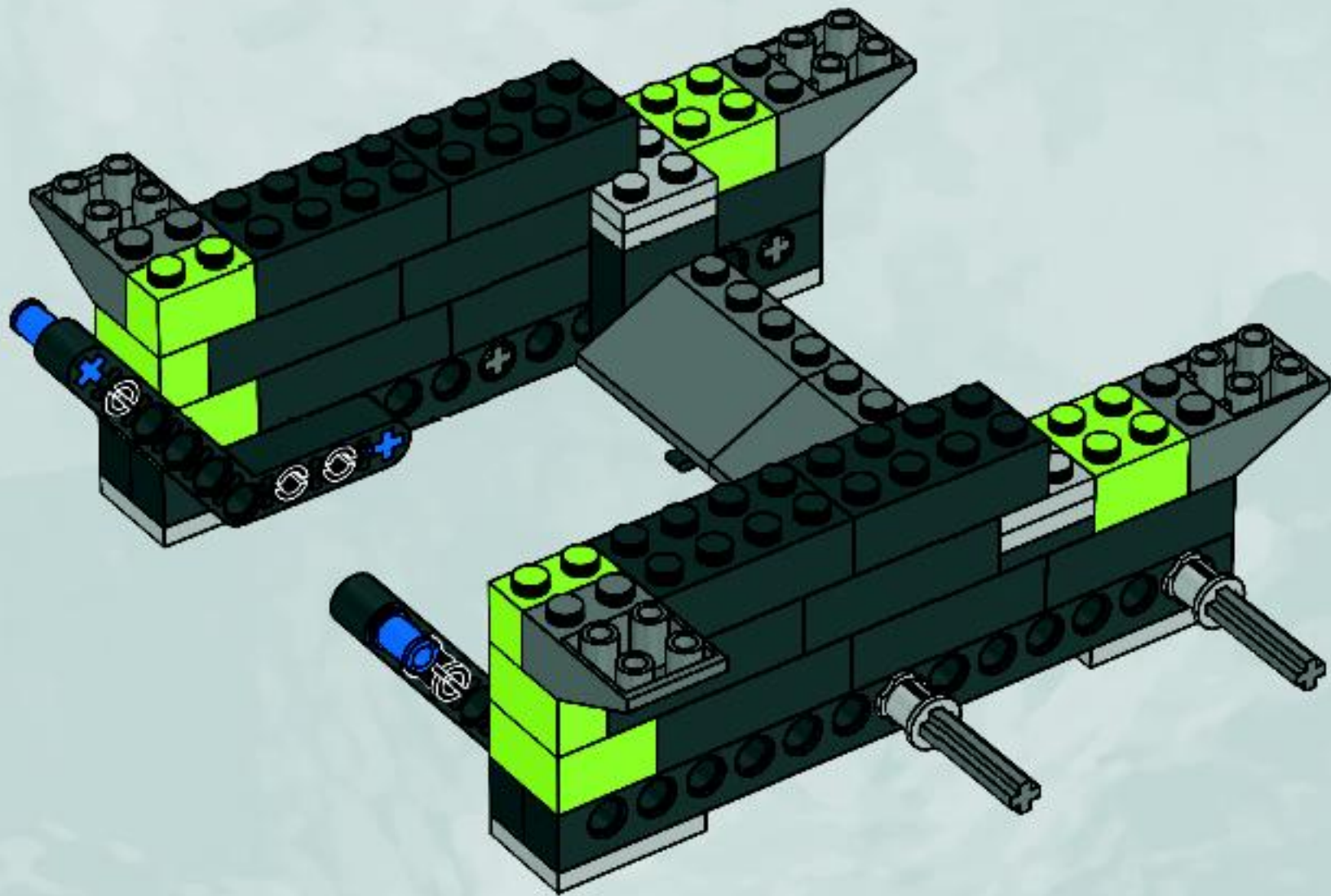

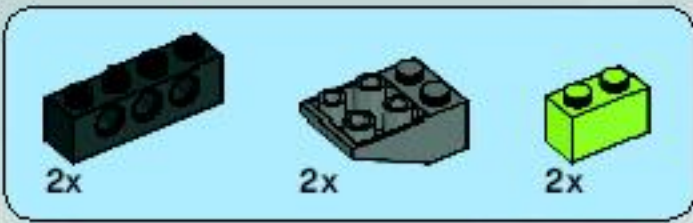

15

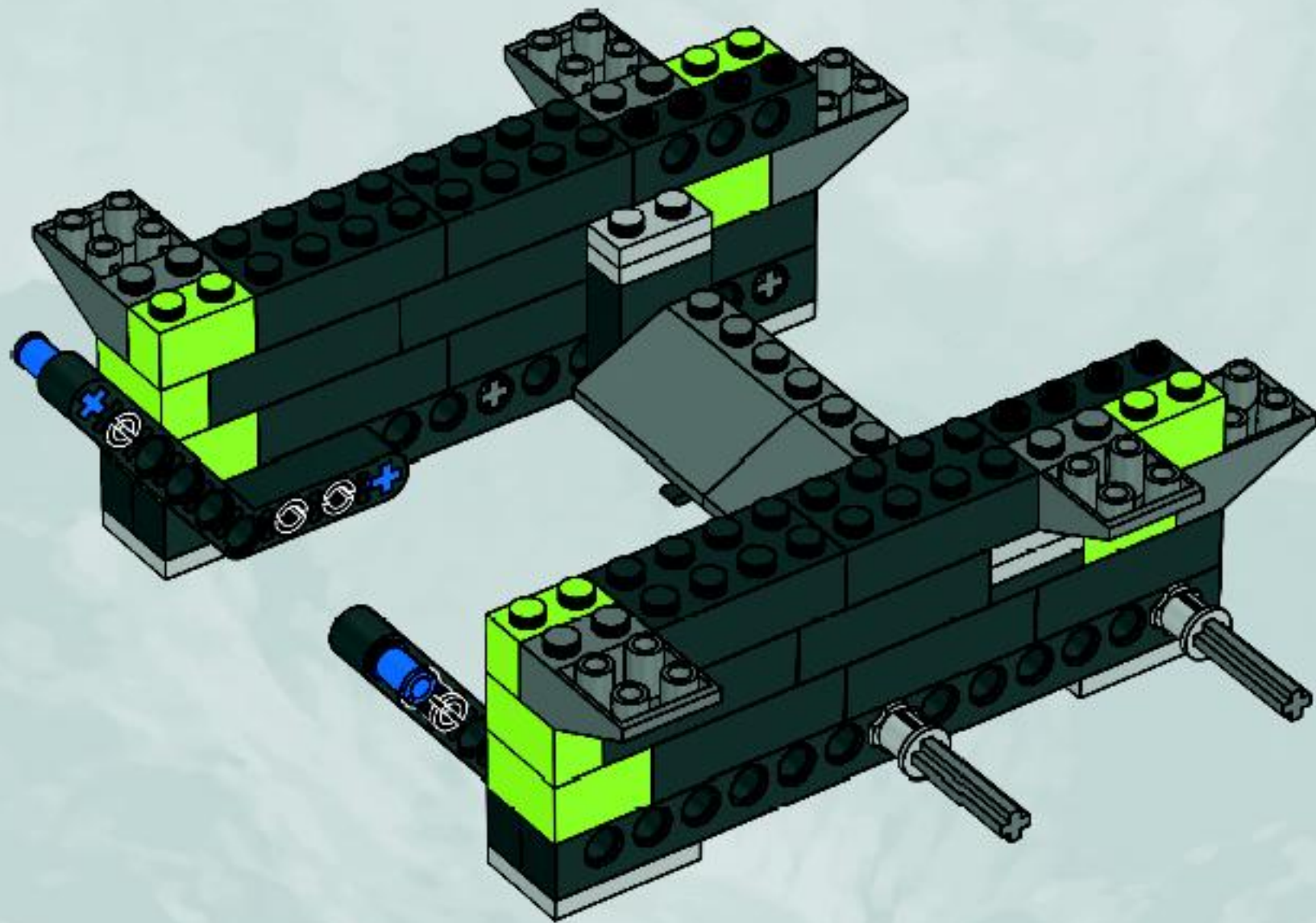

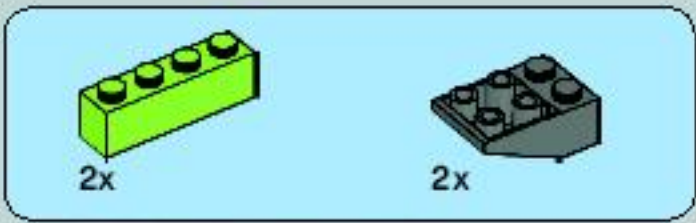

16

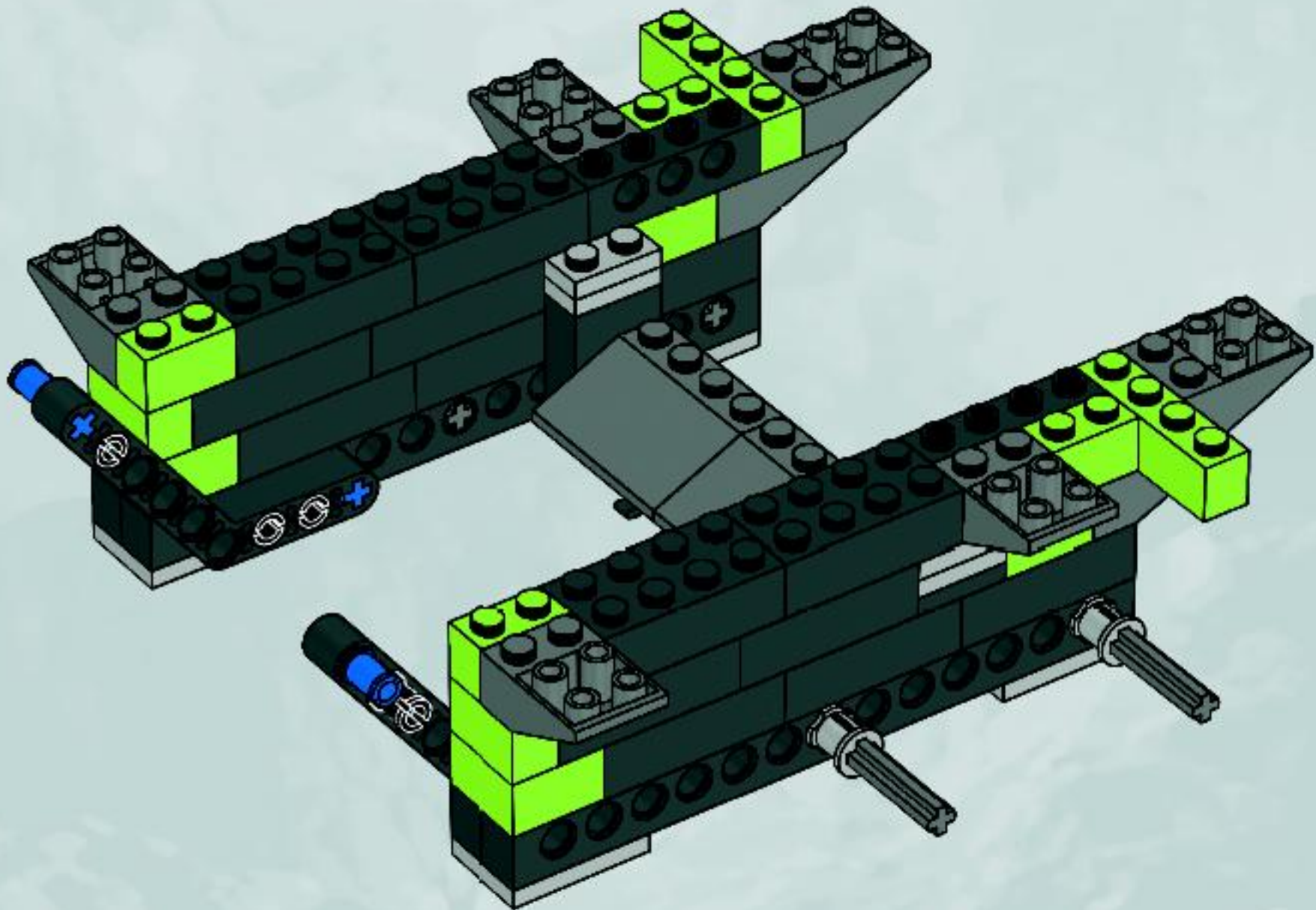

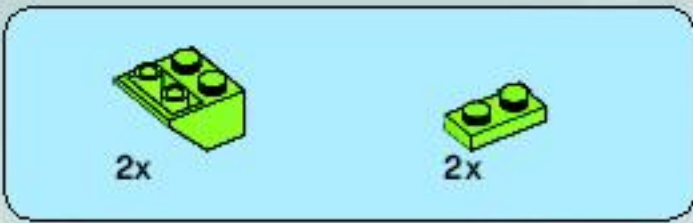

17

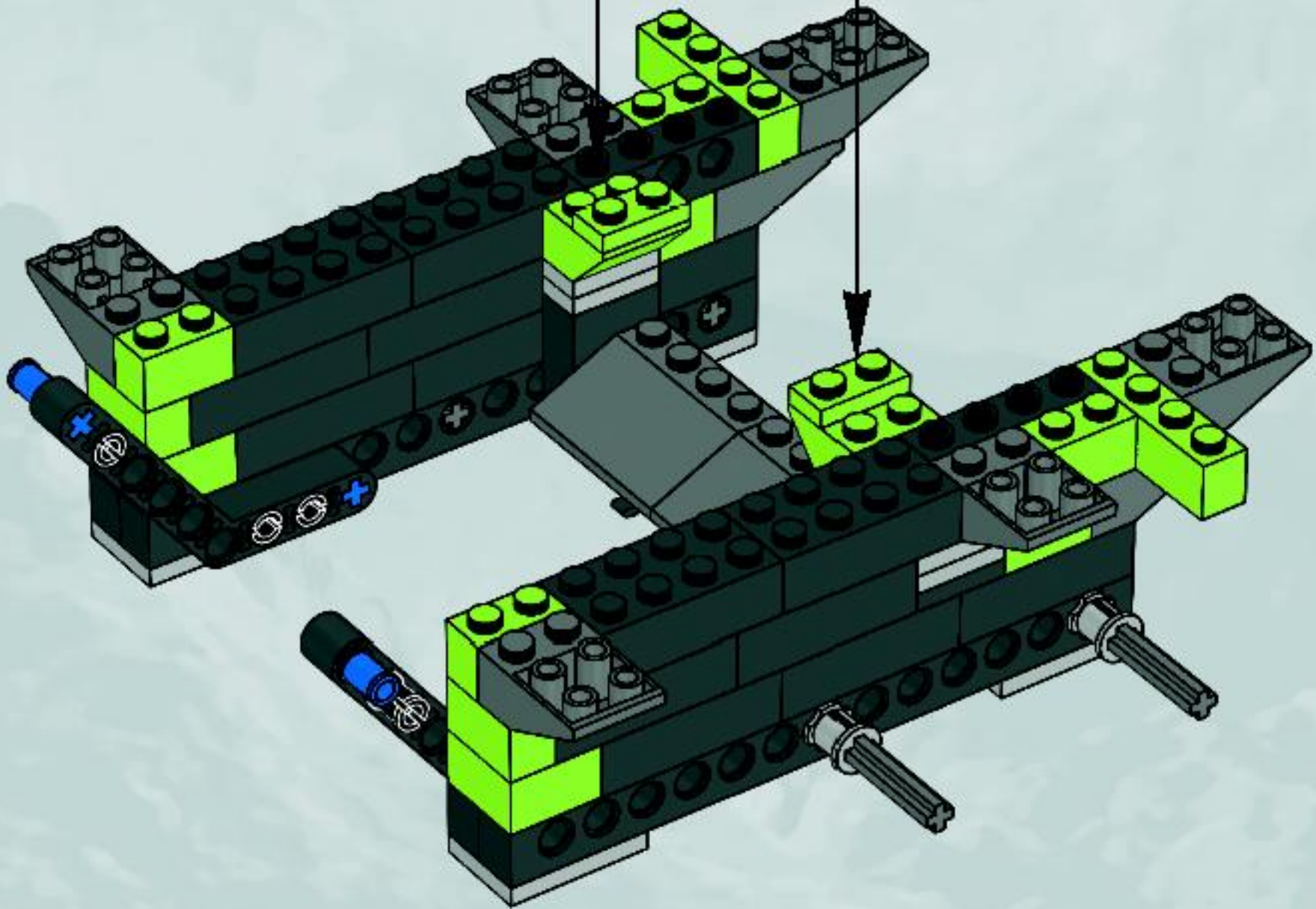
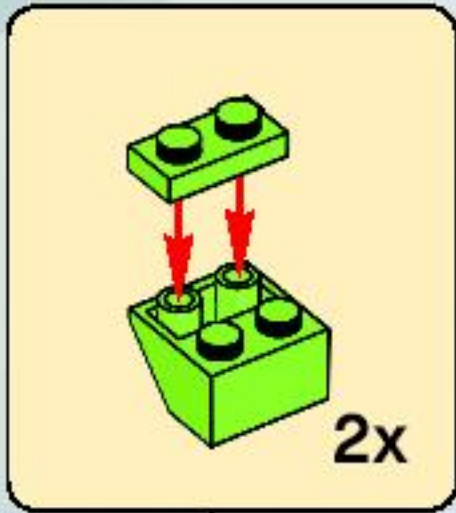

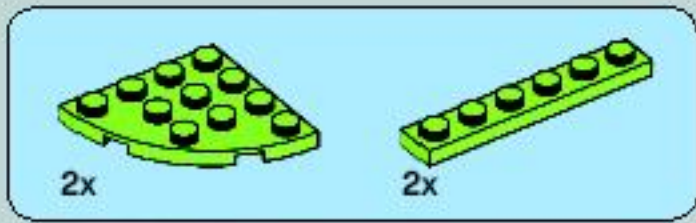

18

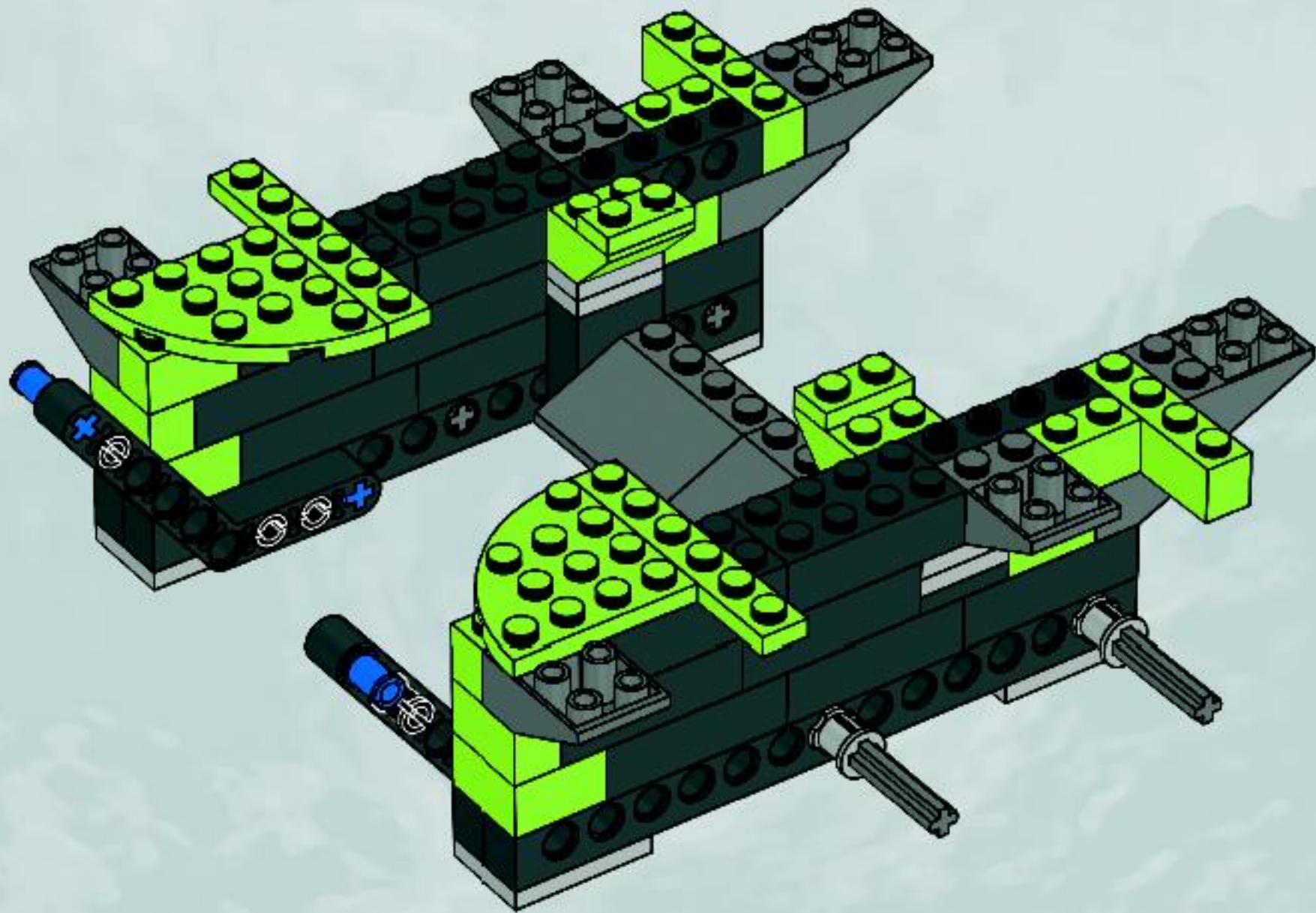

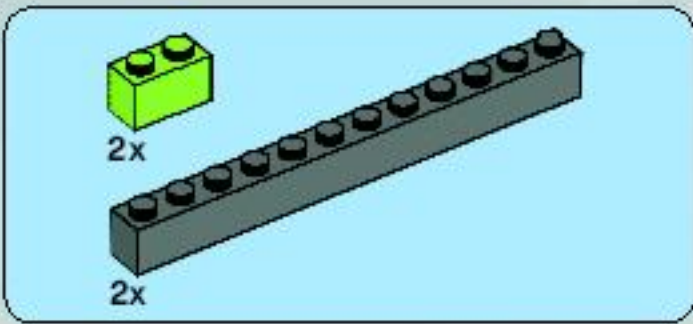

19



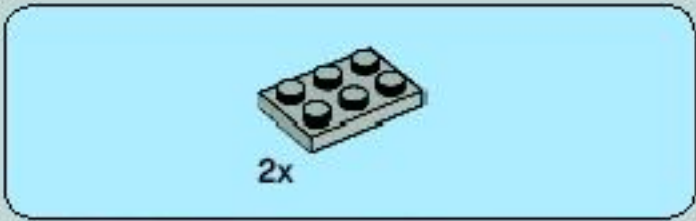

20

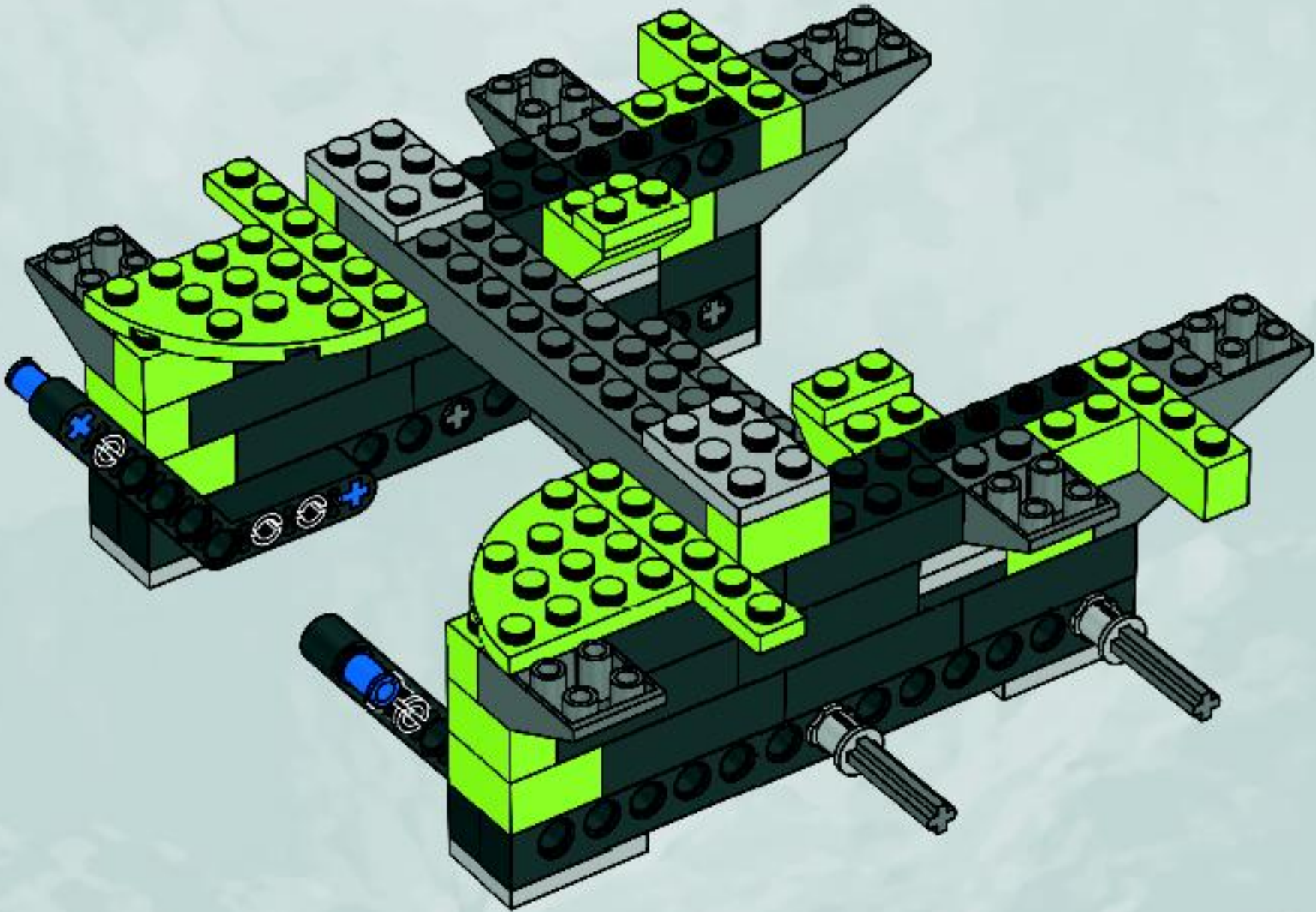

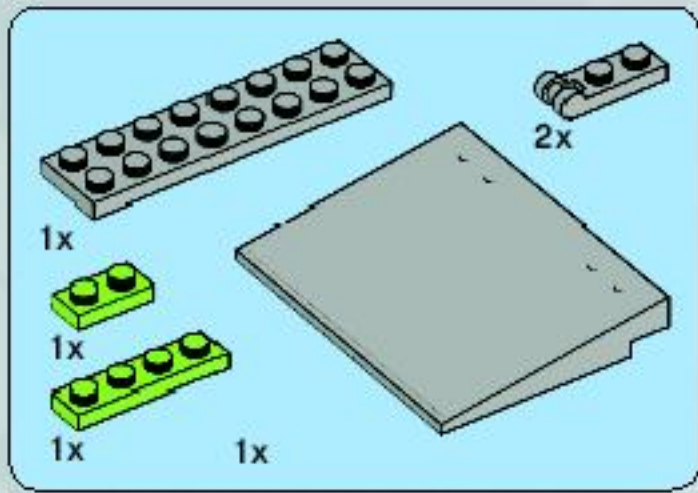

21

1



2

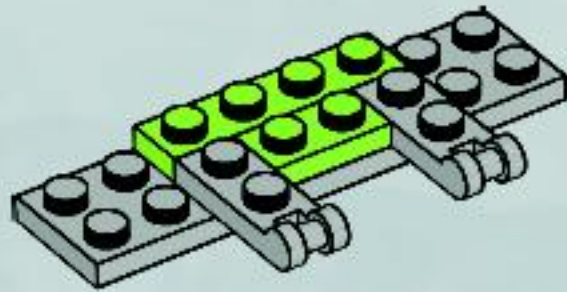

3

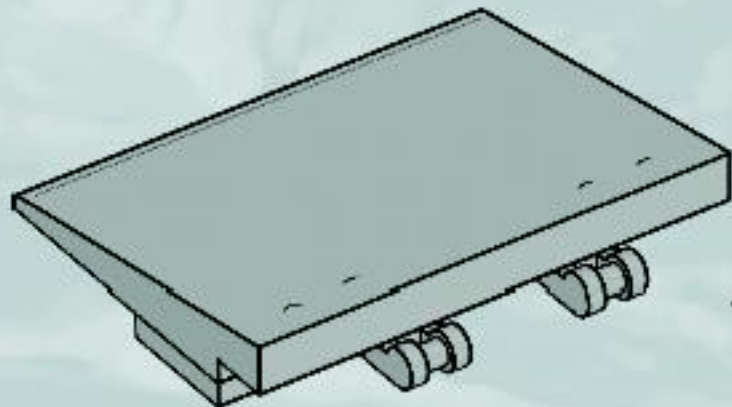

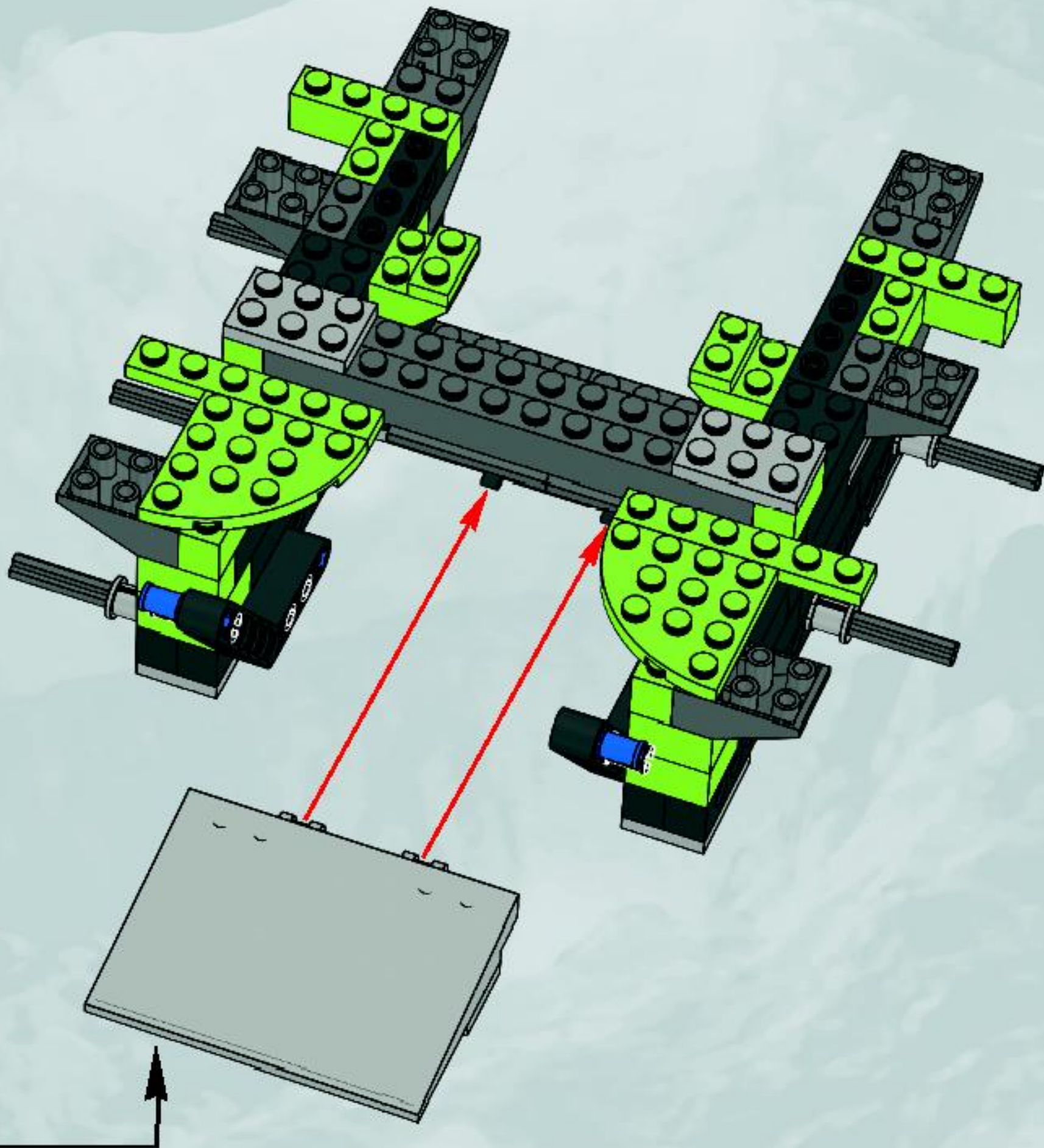

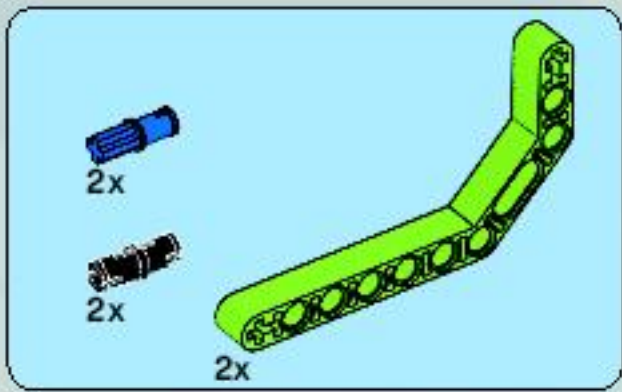

22

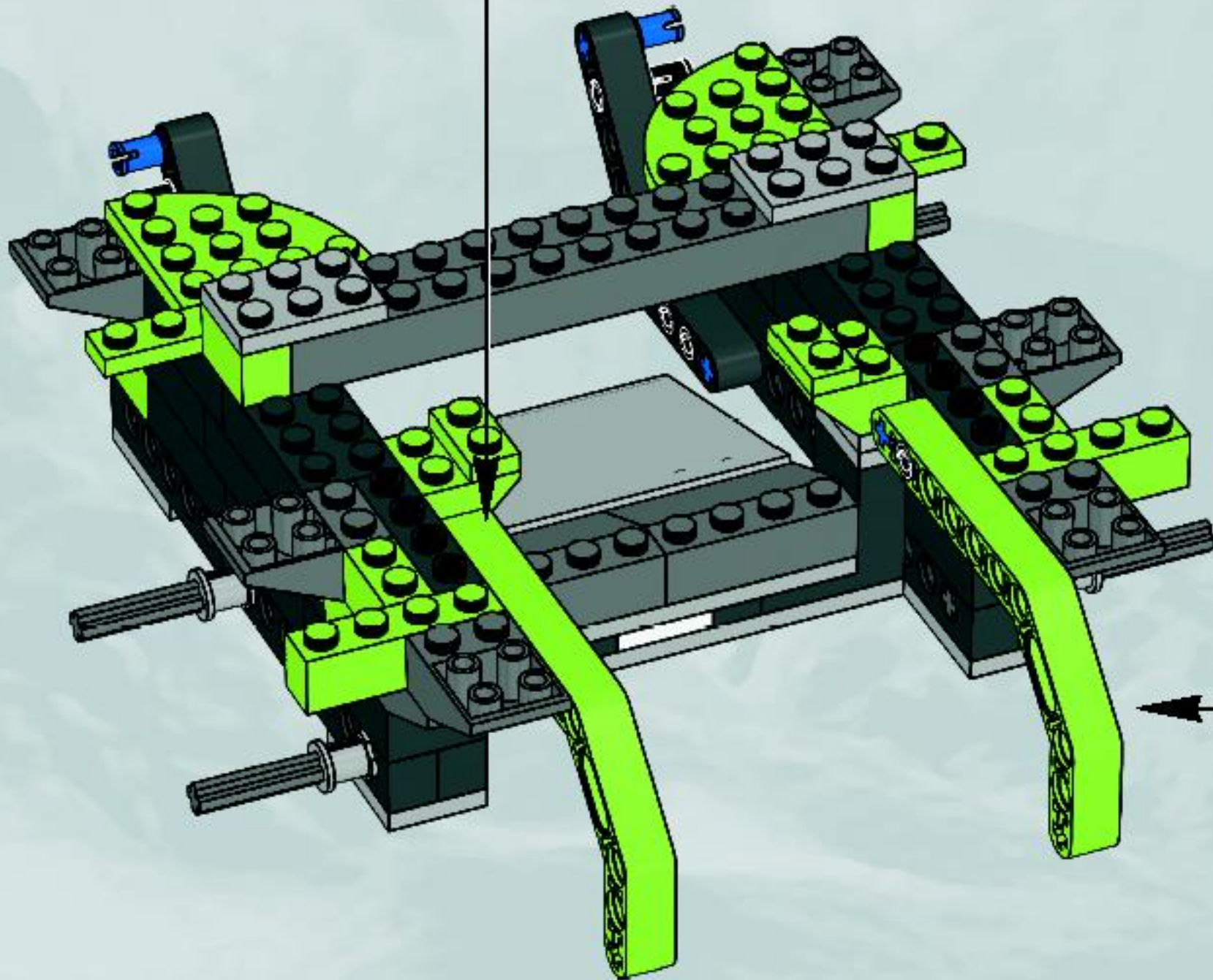
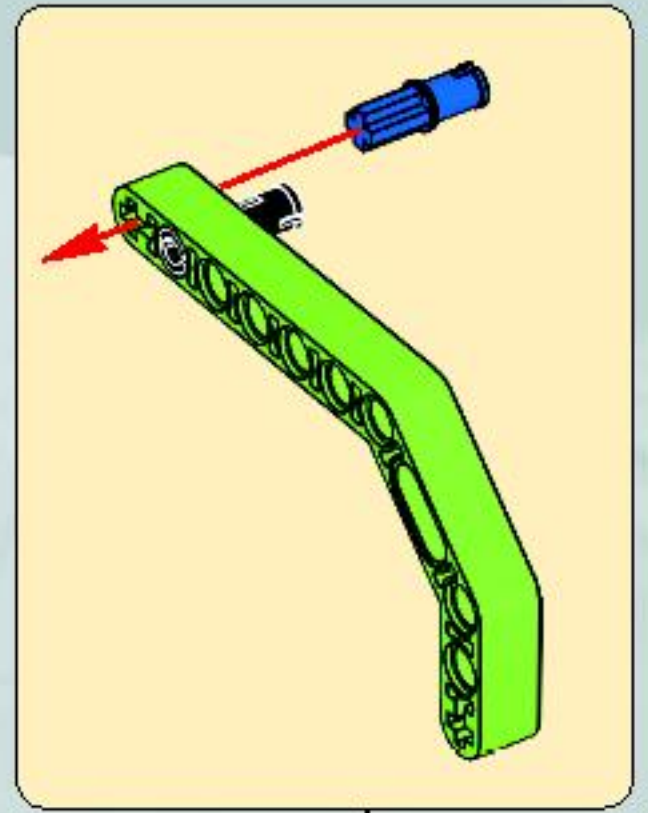
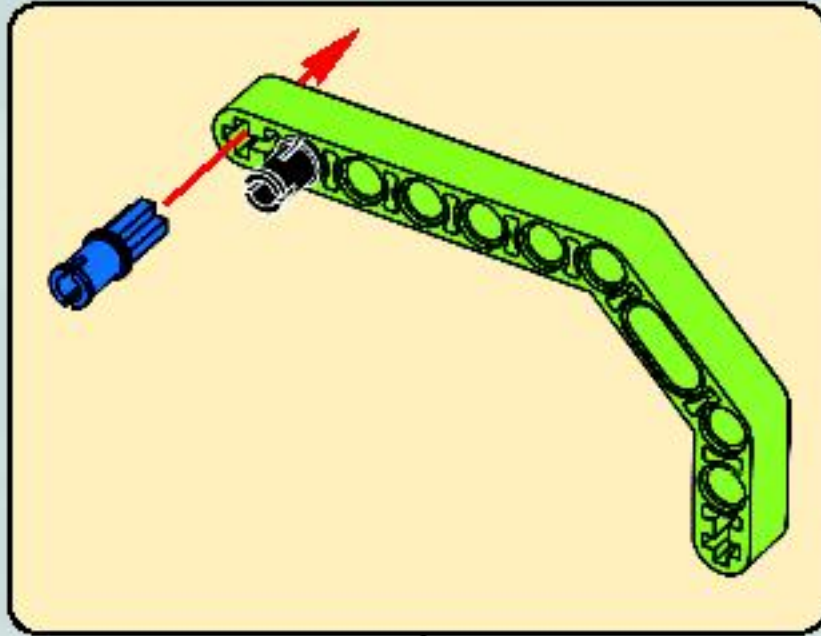

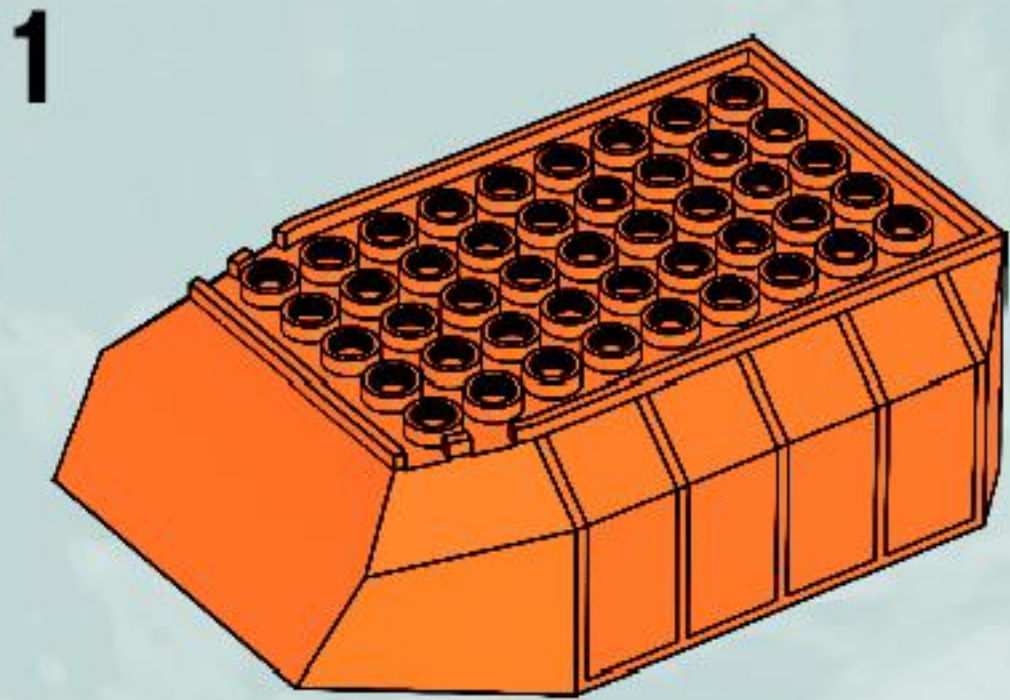
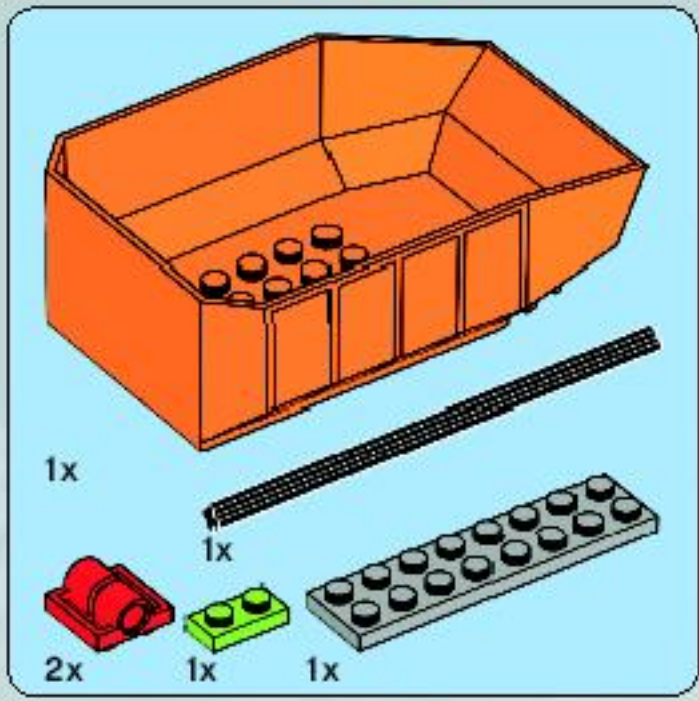

2

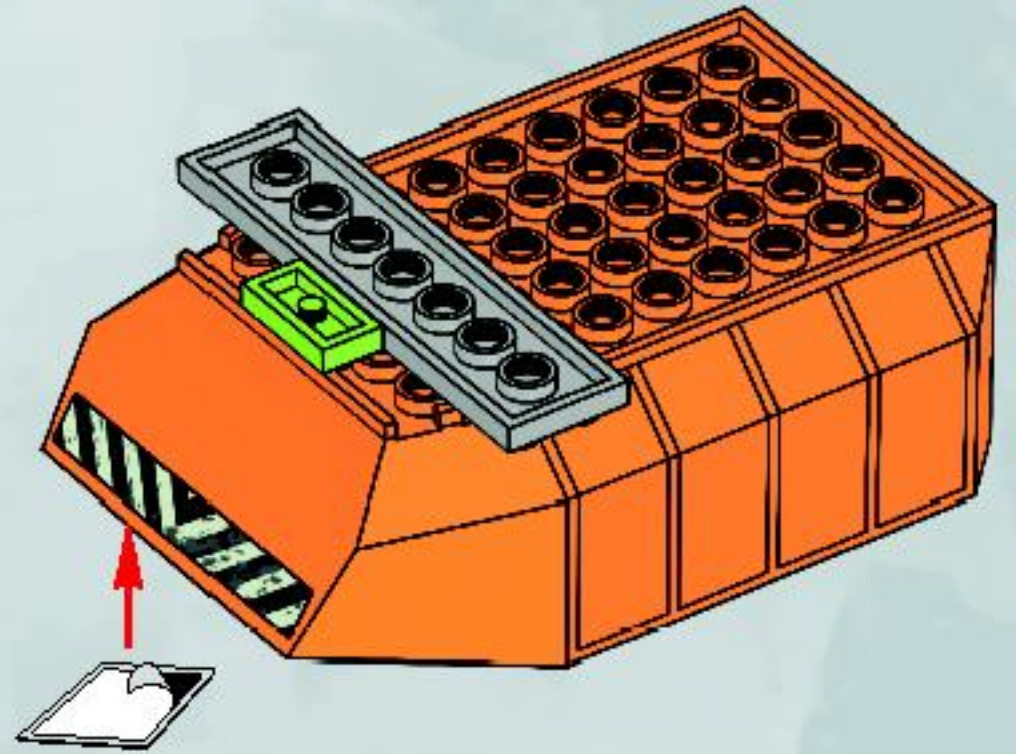

3

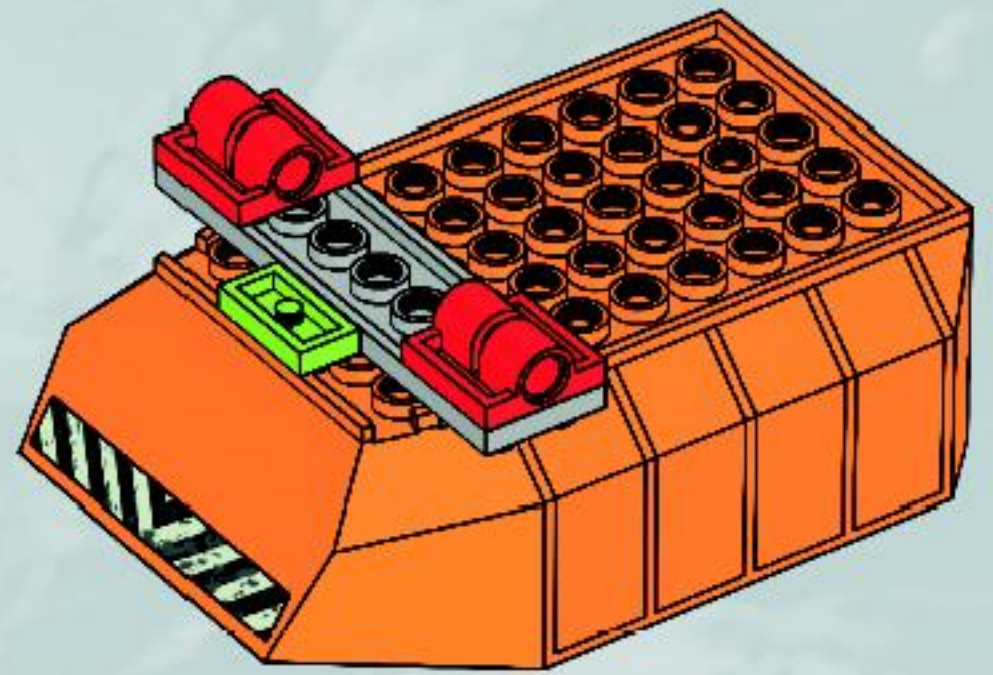

23

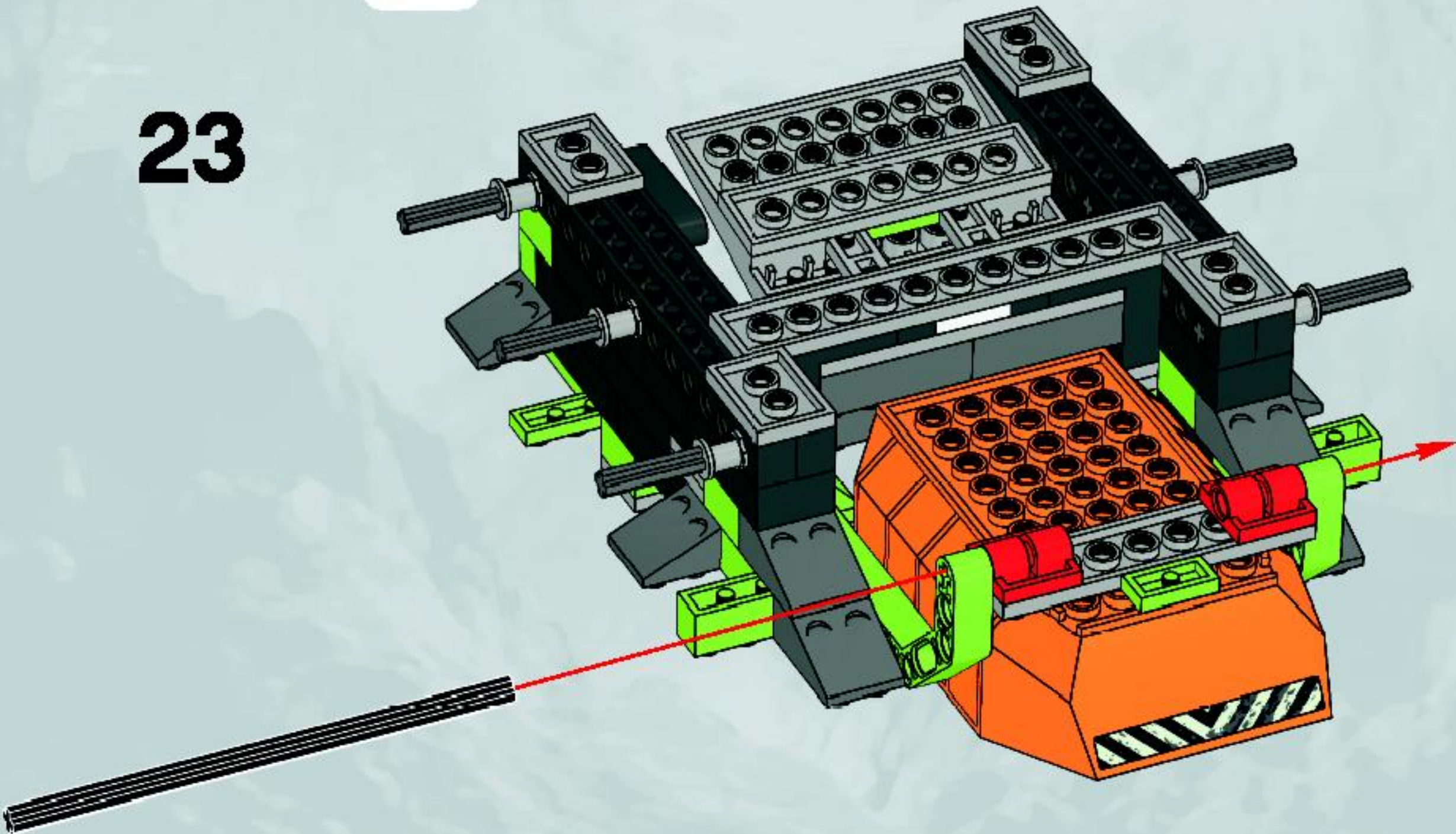



2x



2x

24

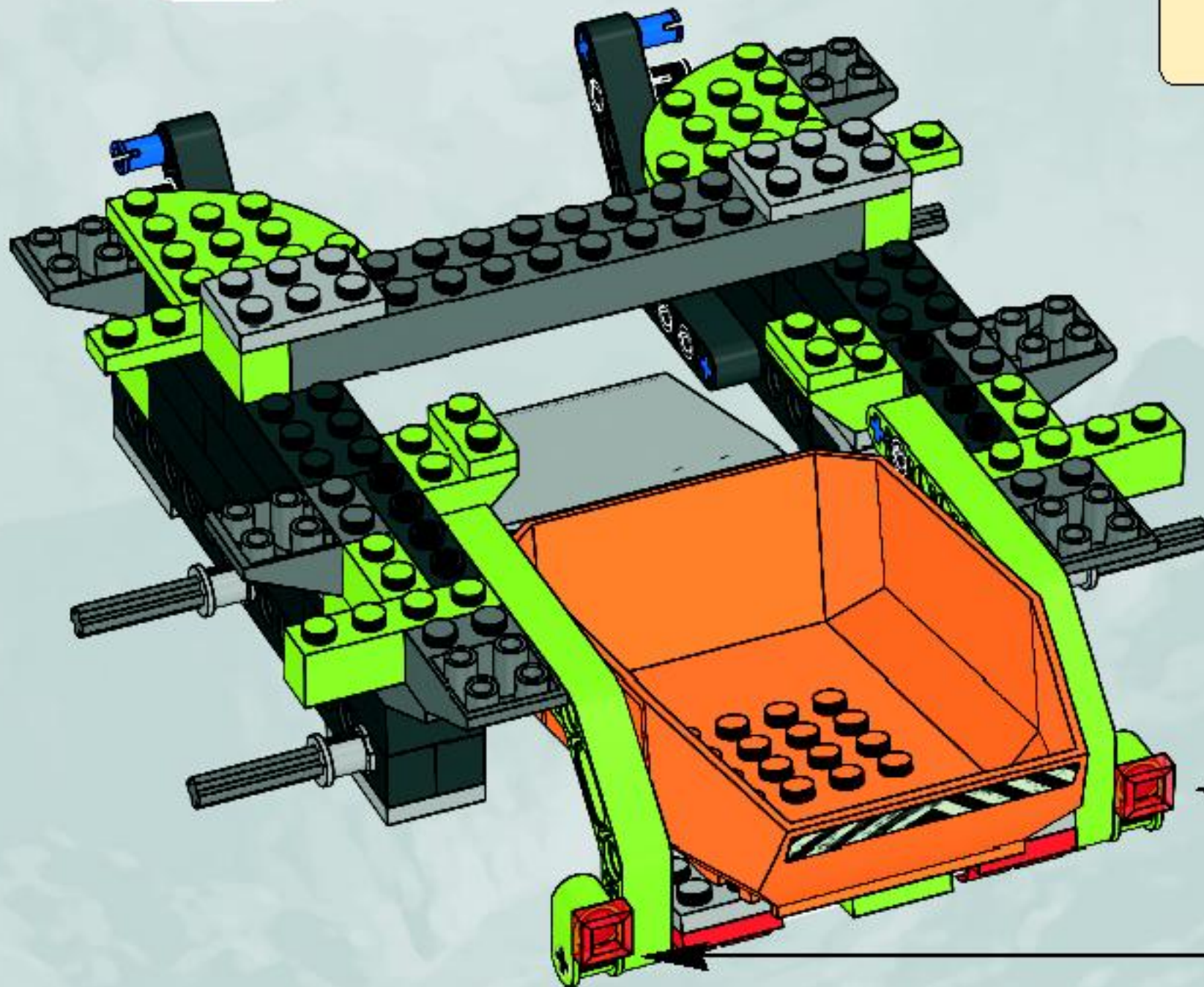

2x

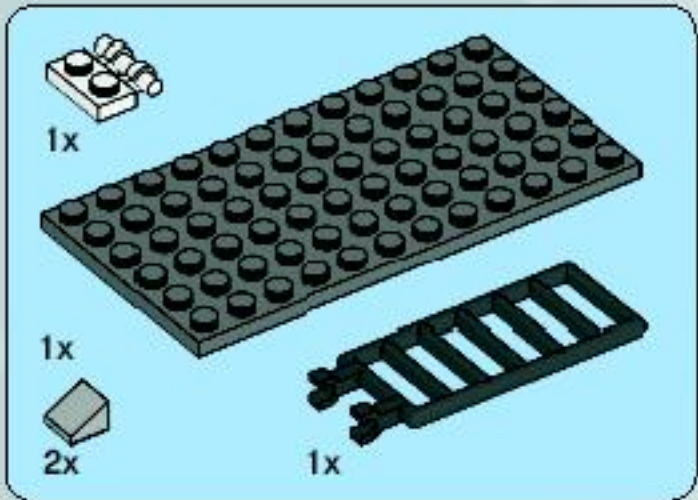
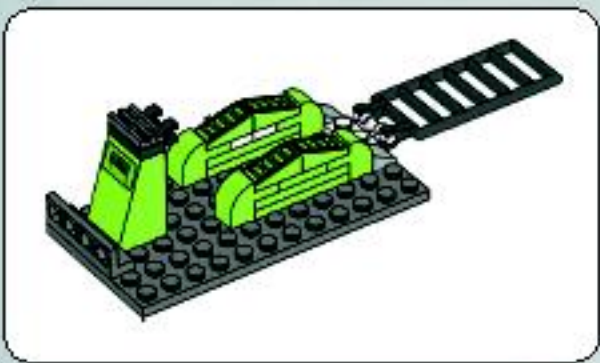
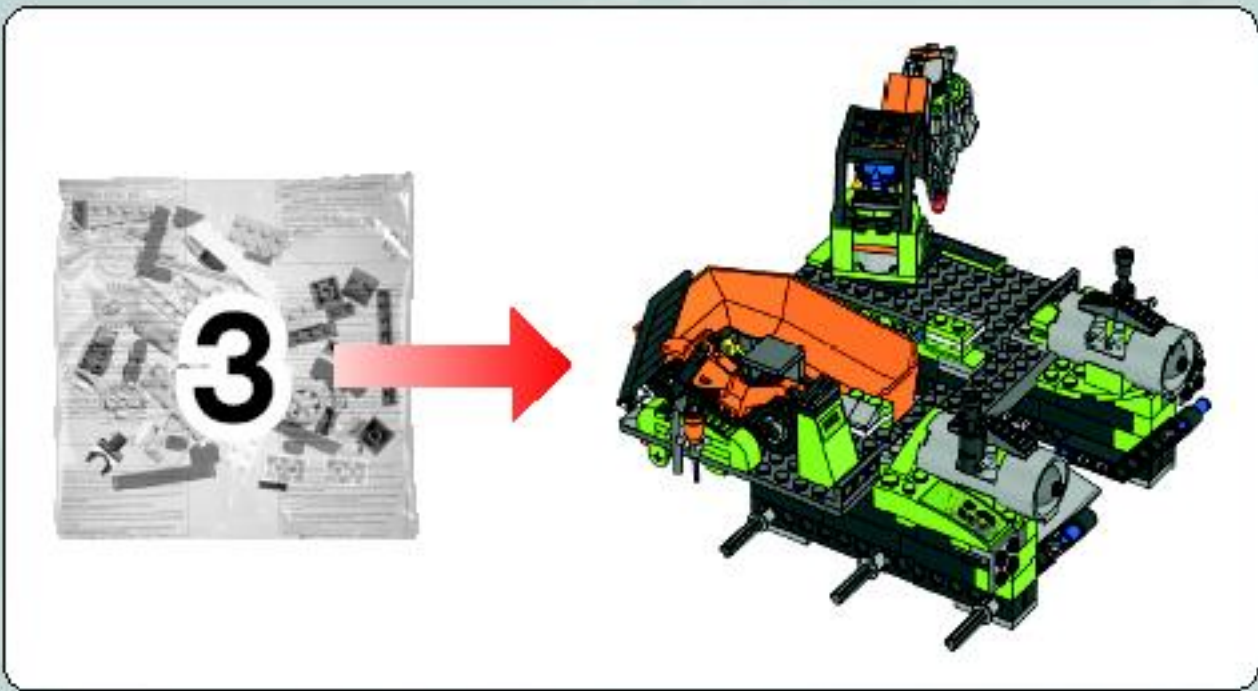

1

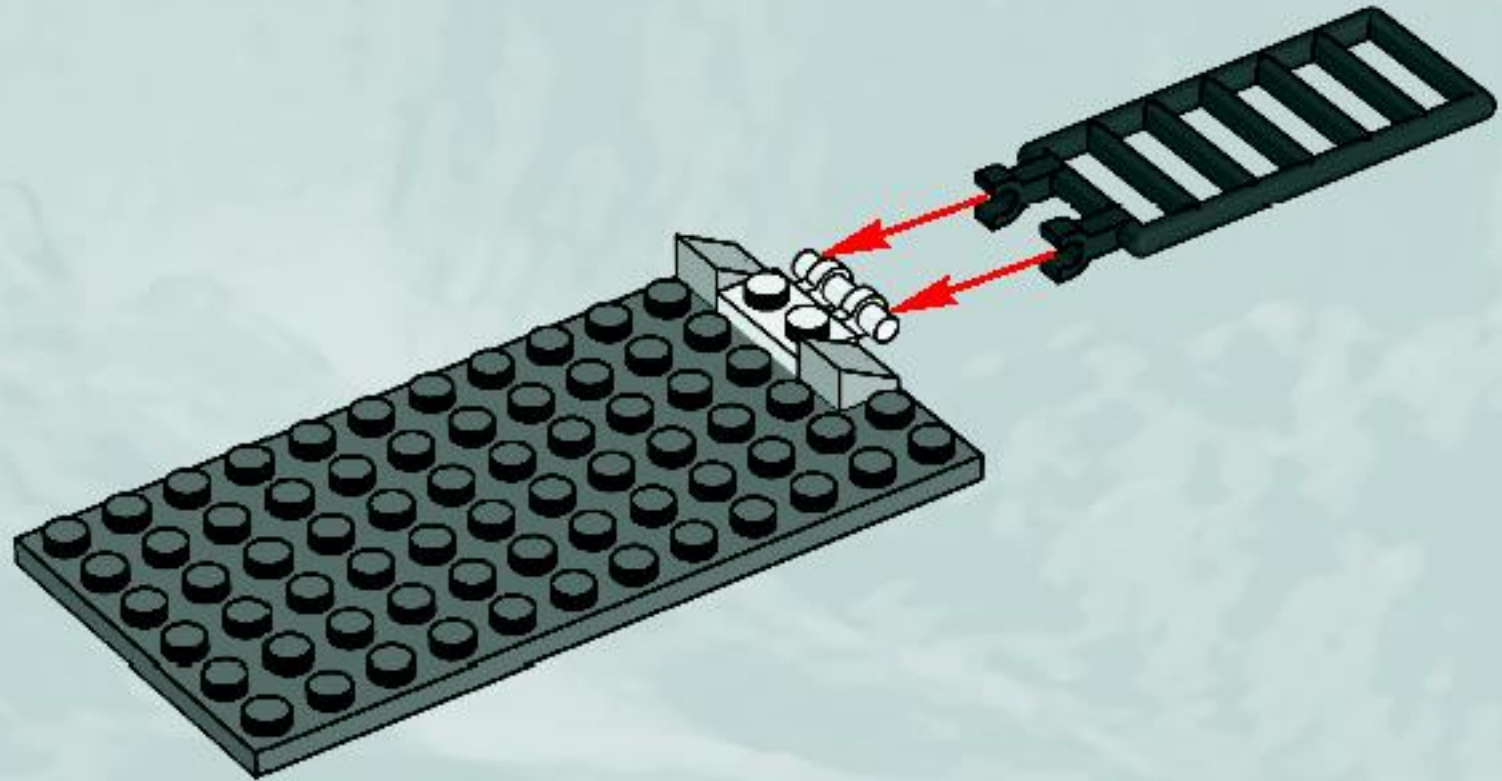

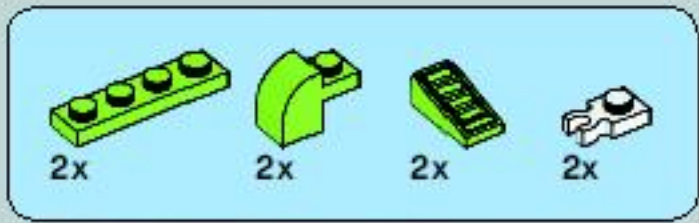

2

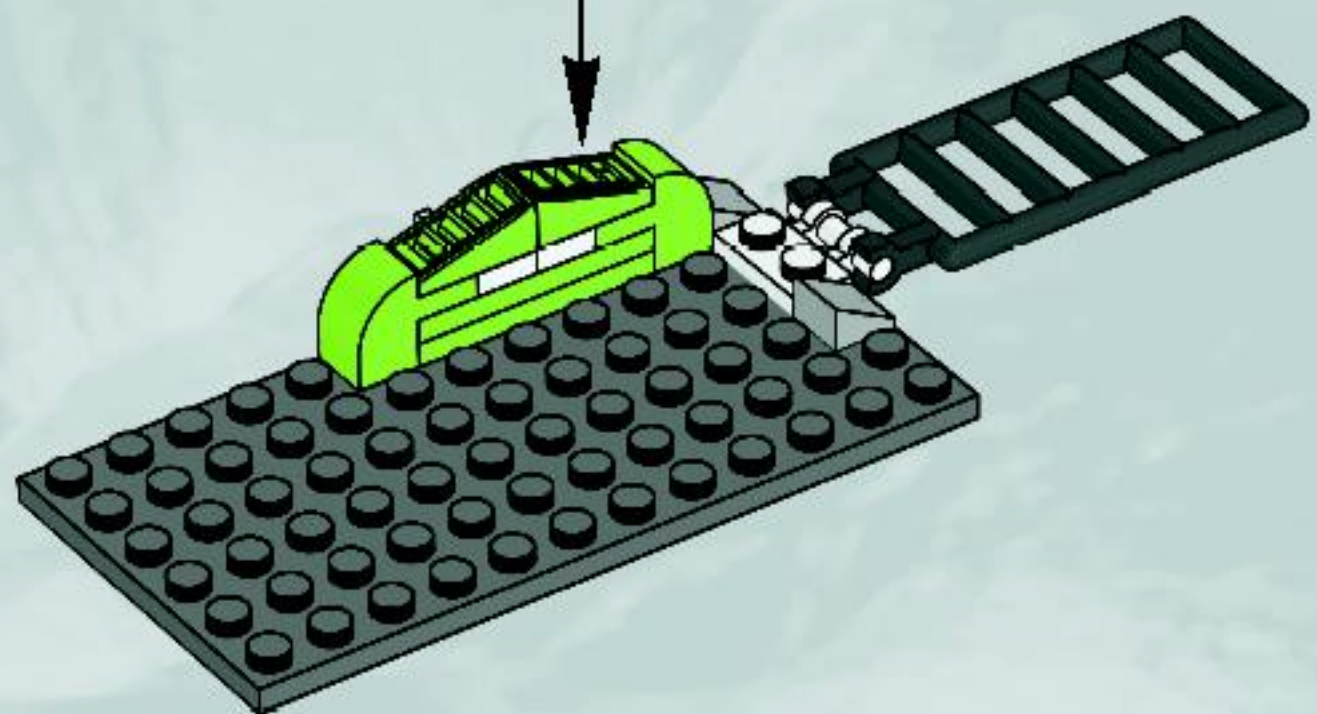
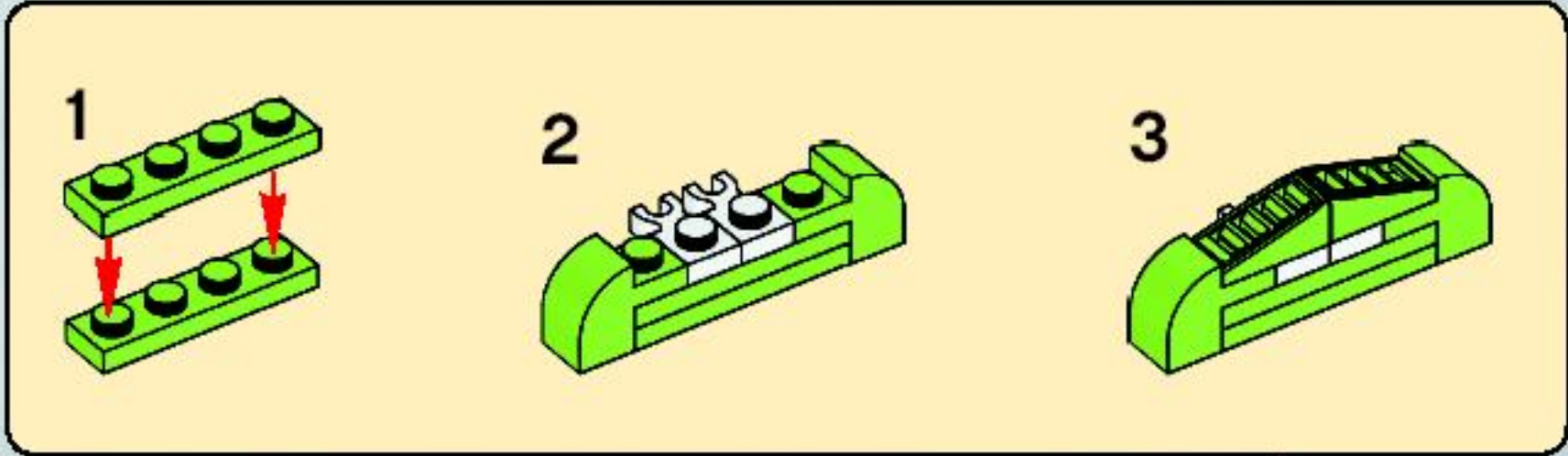

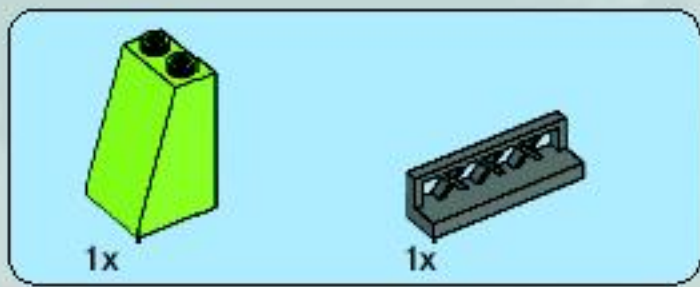

3

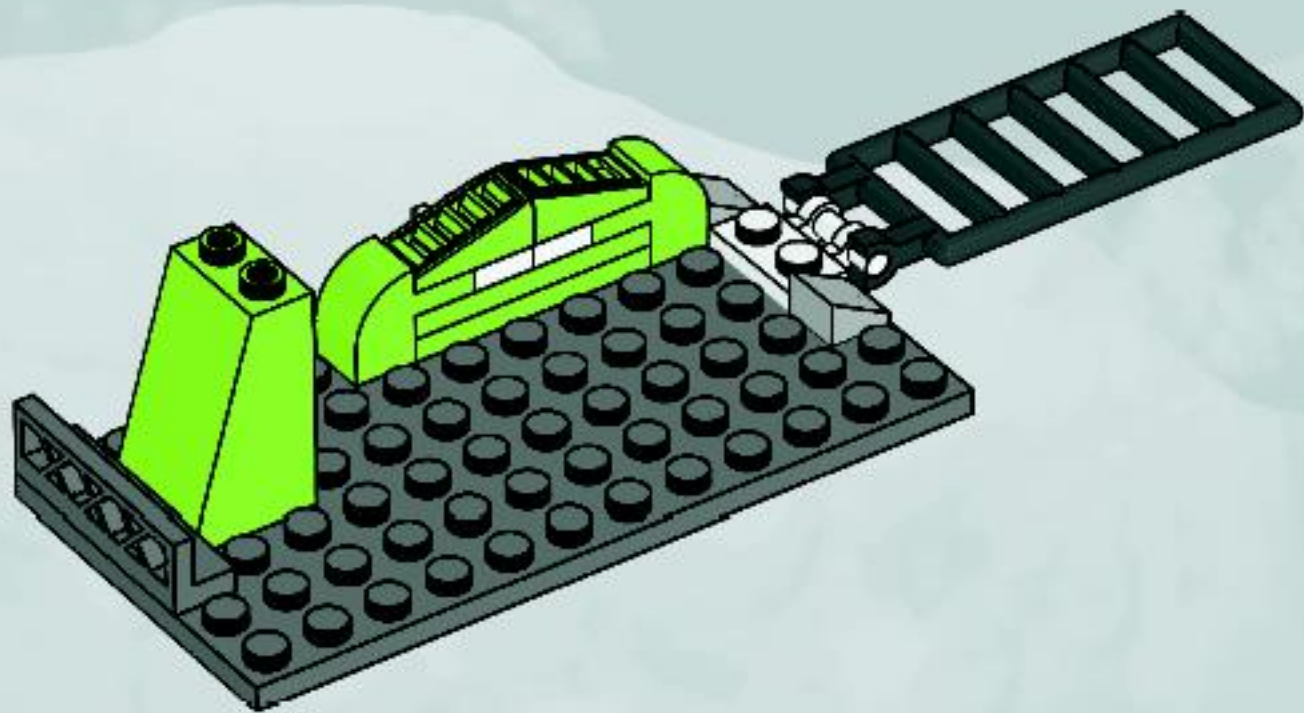

4

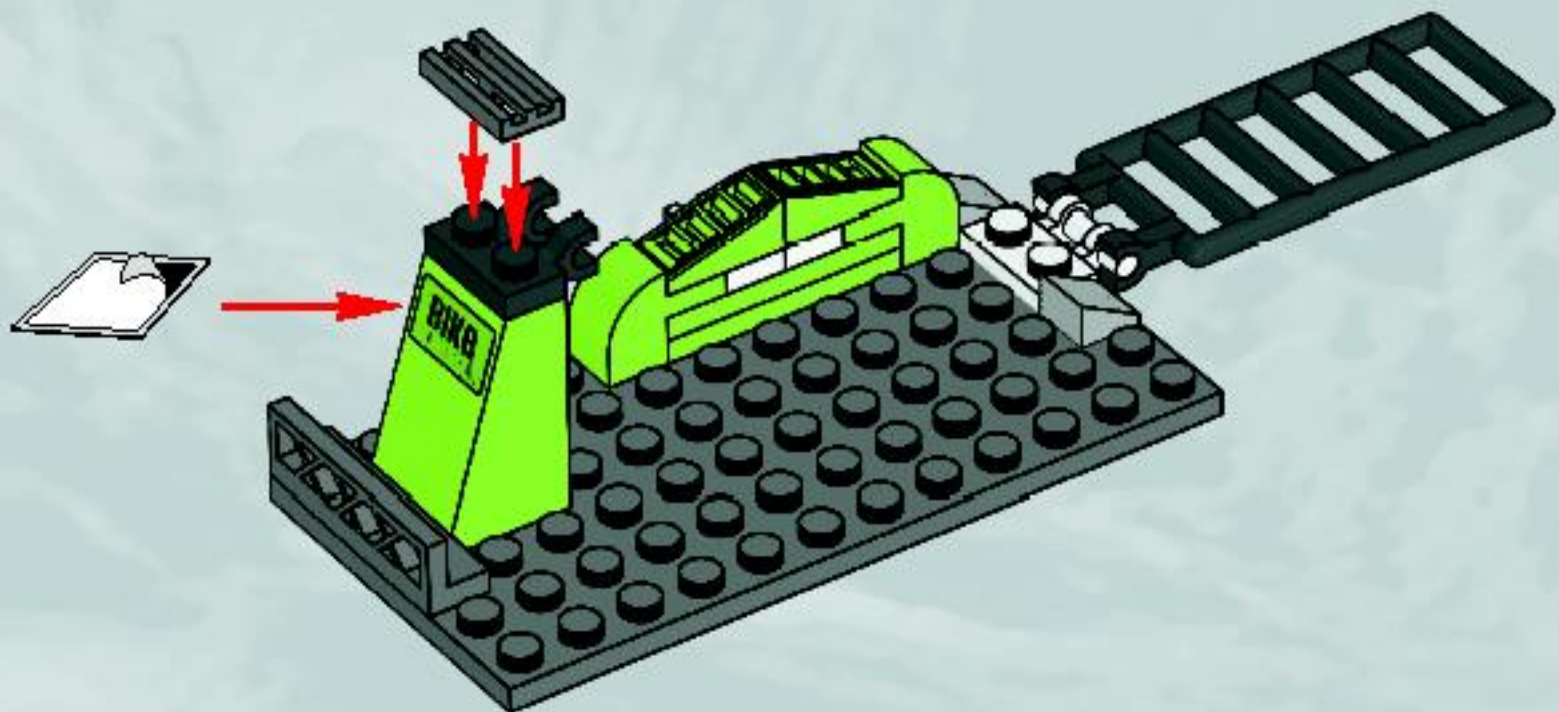

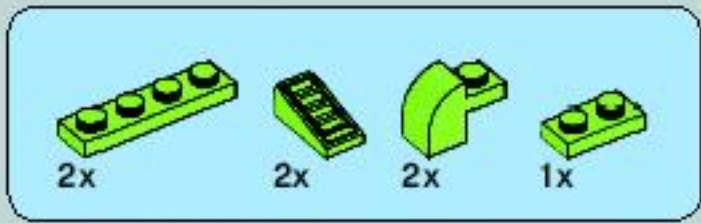

5

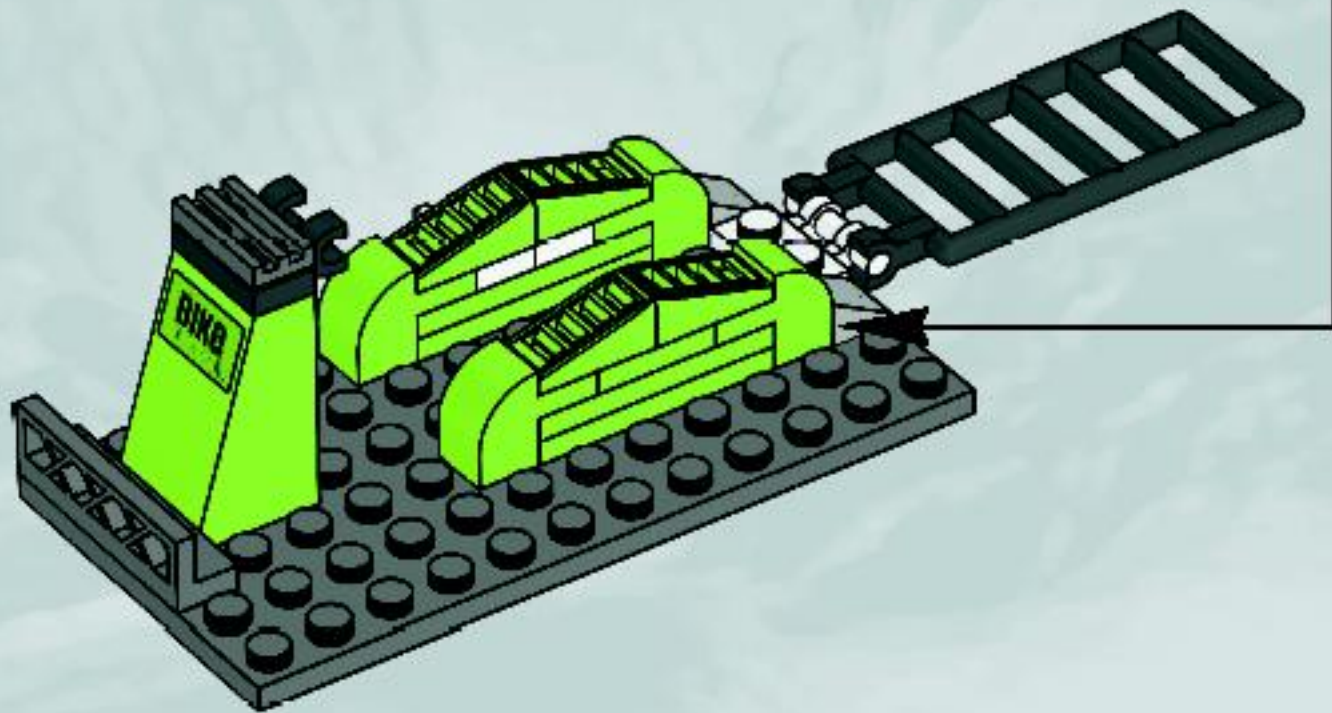
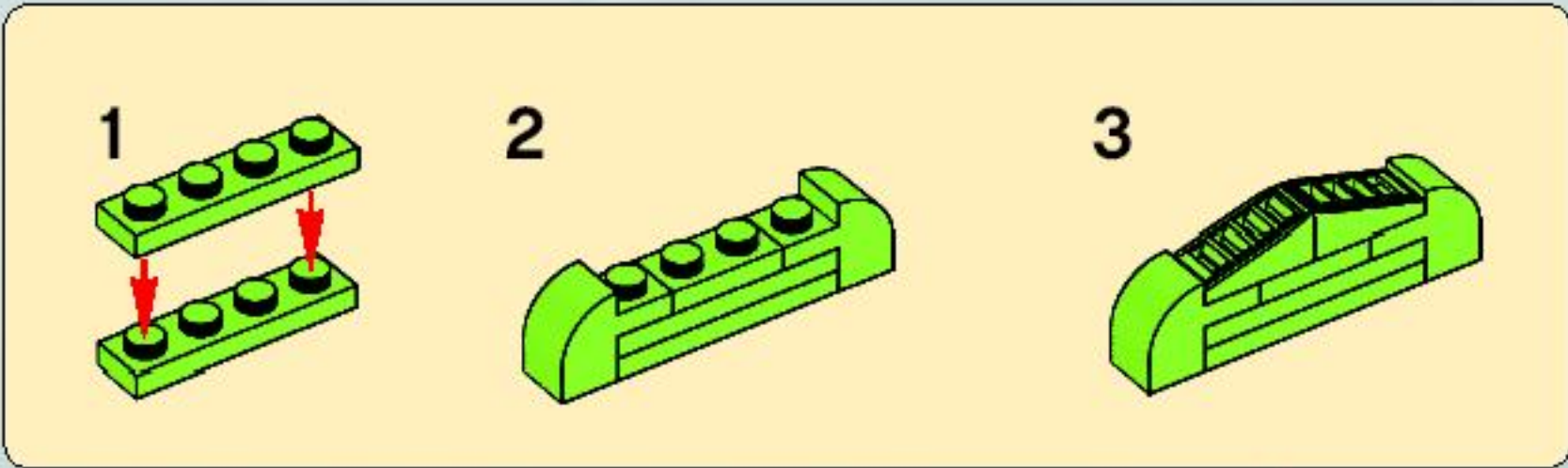



1x



1x

6

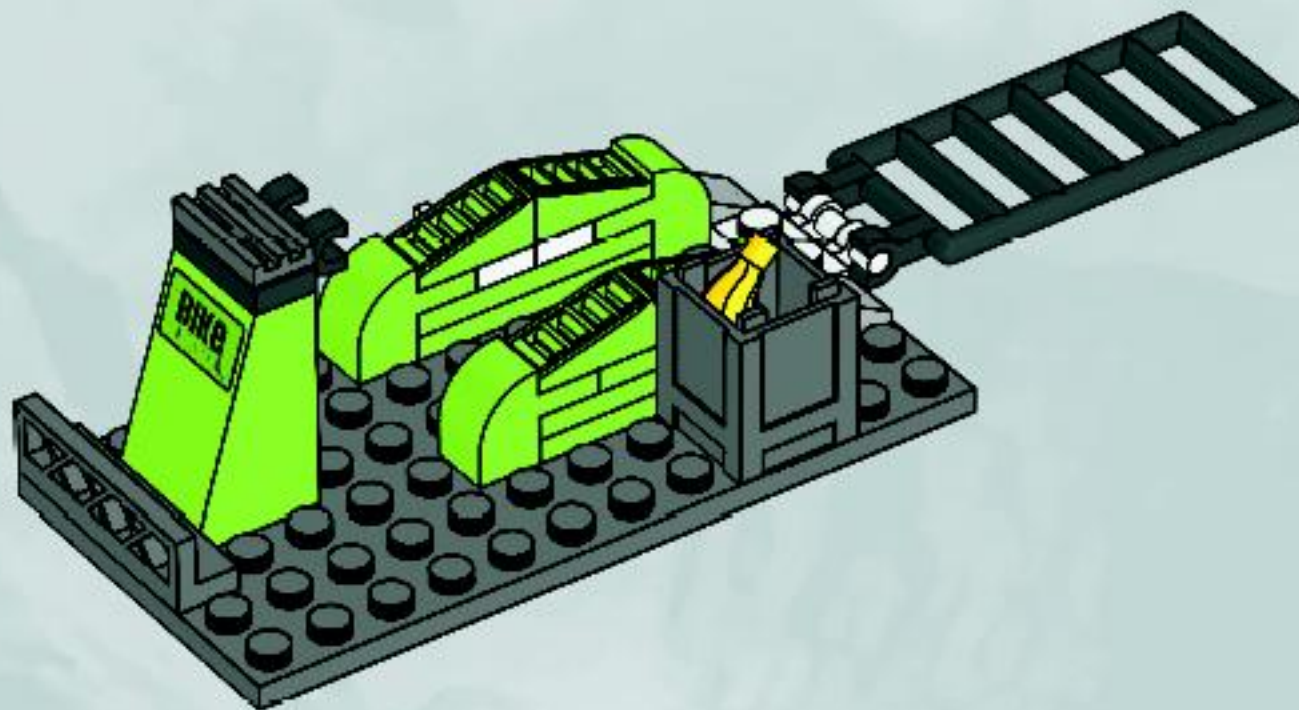

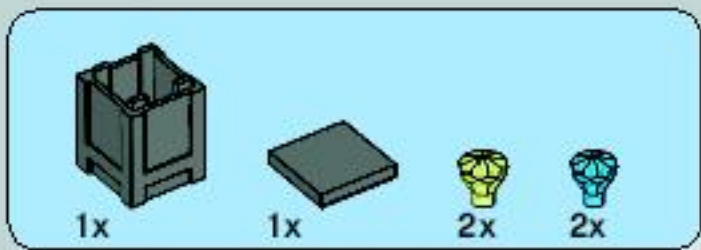

7

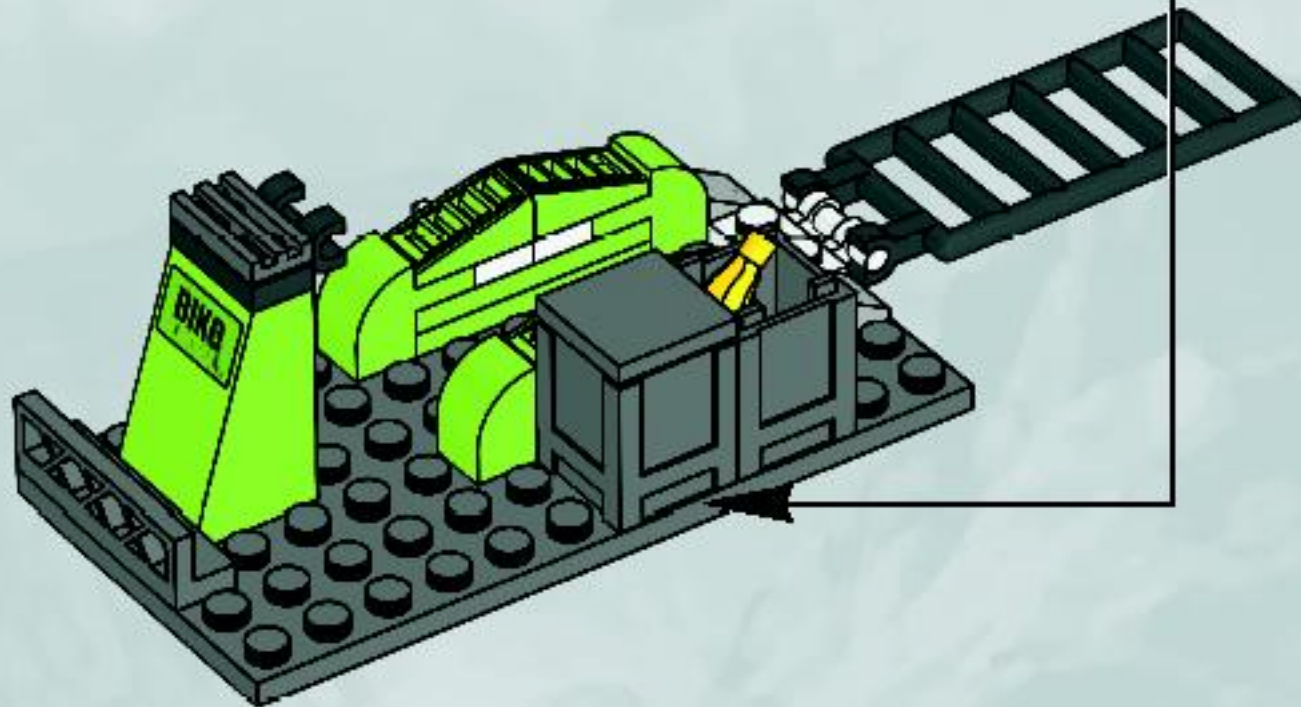
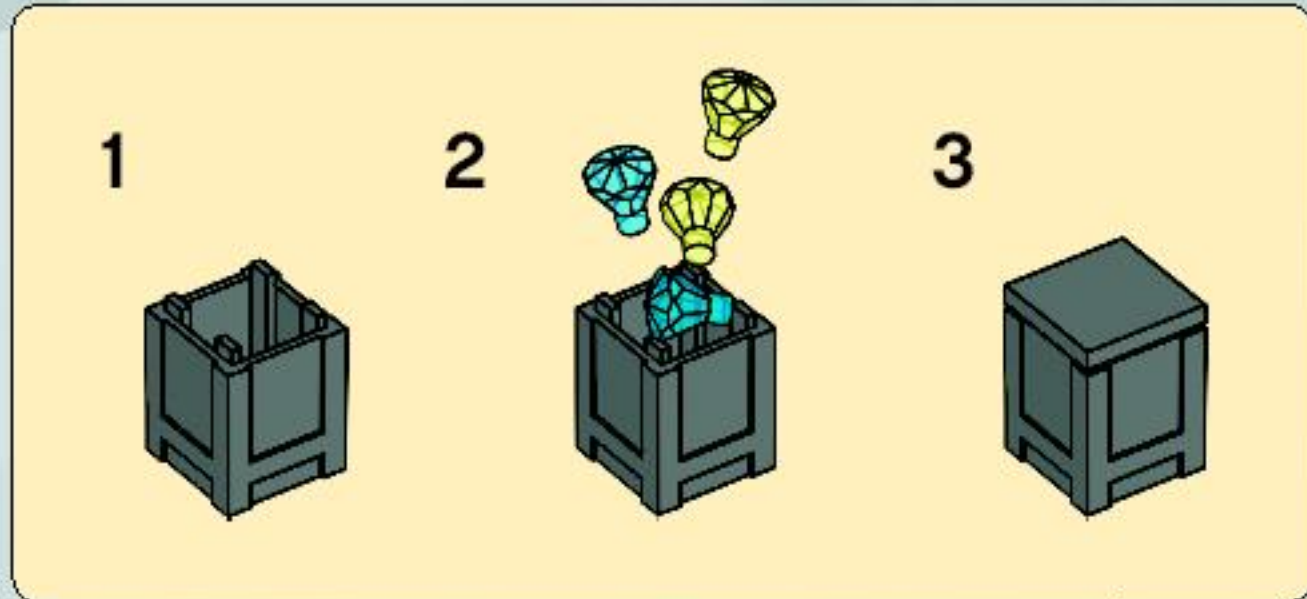

8

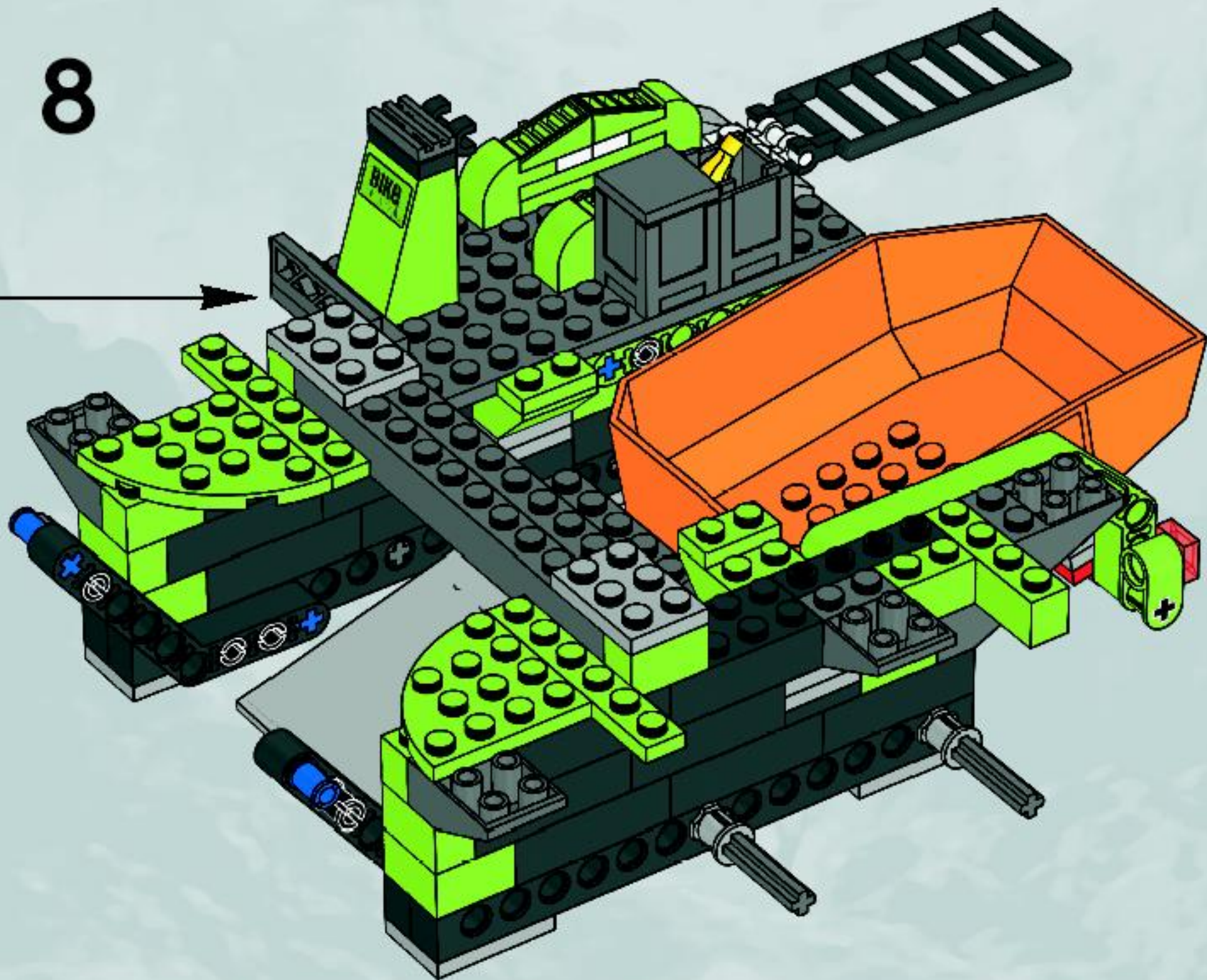

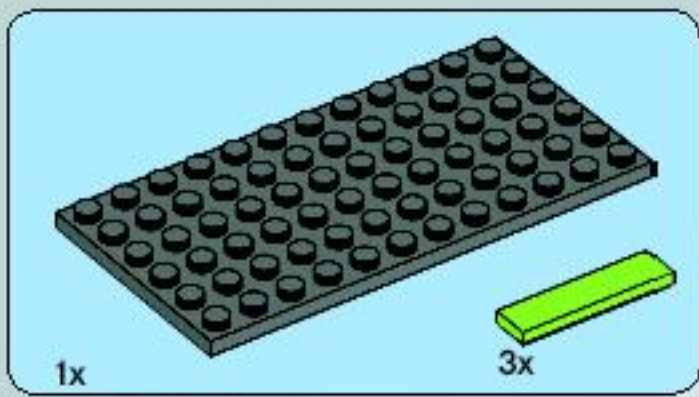

1

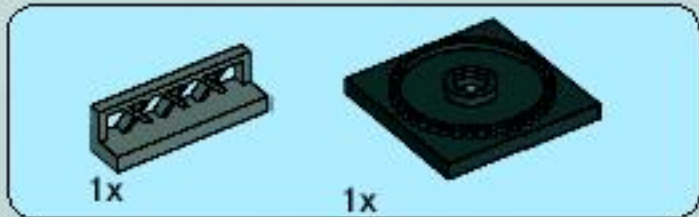
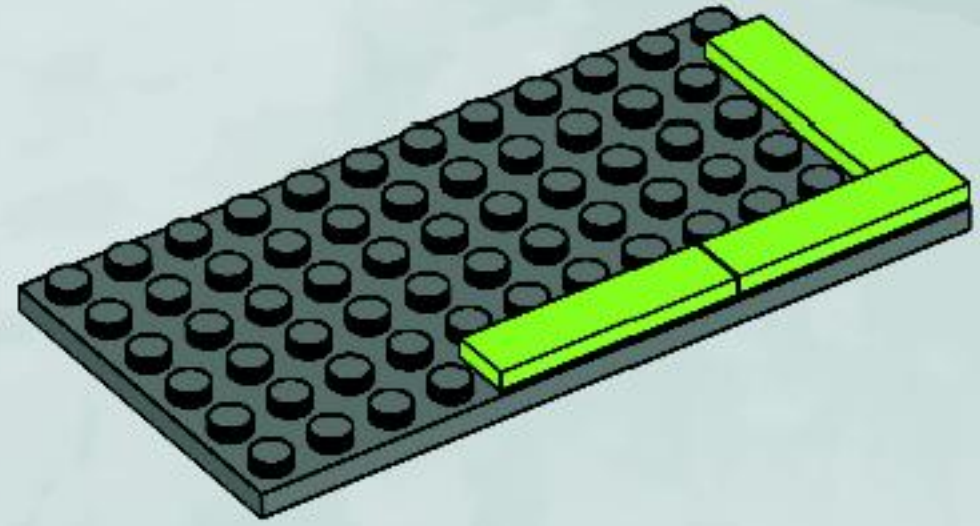

2

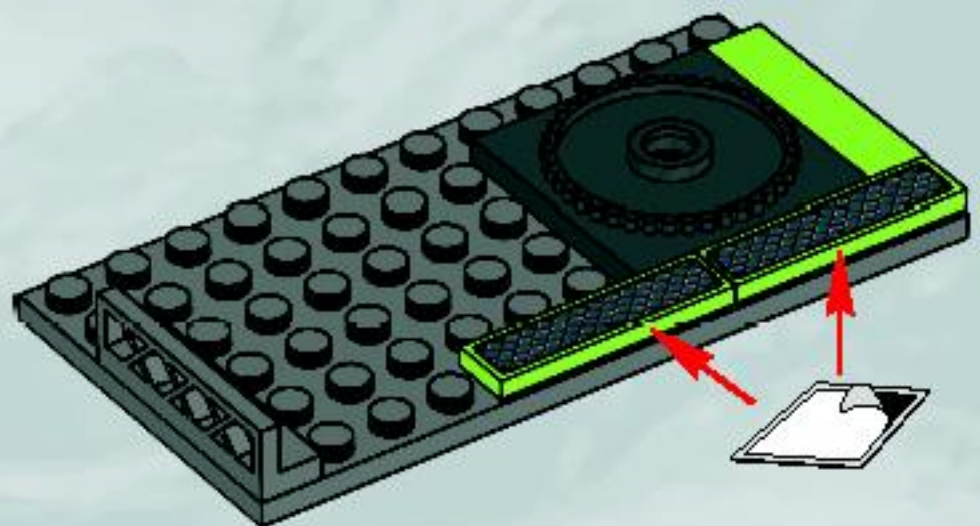

9

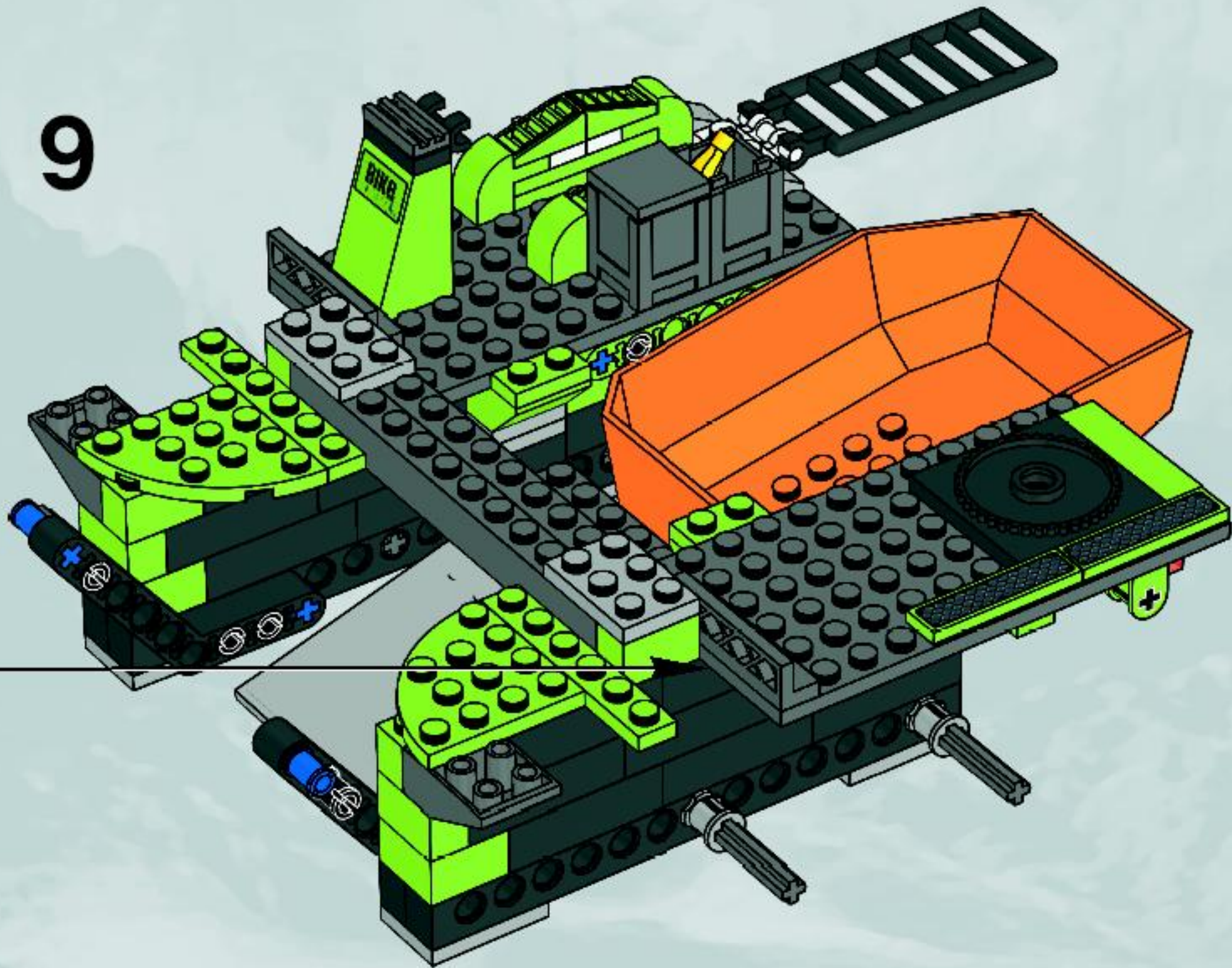

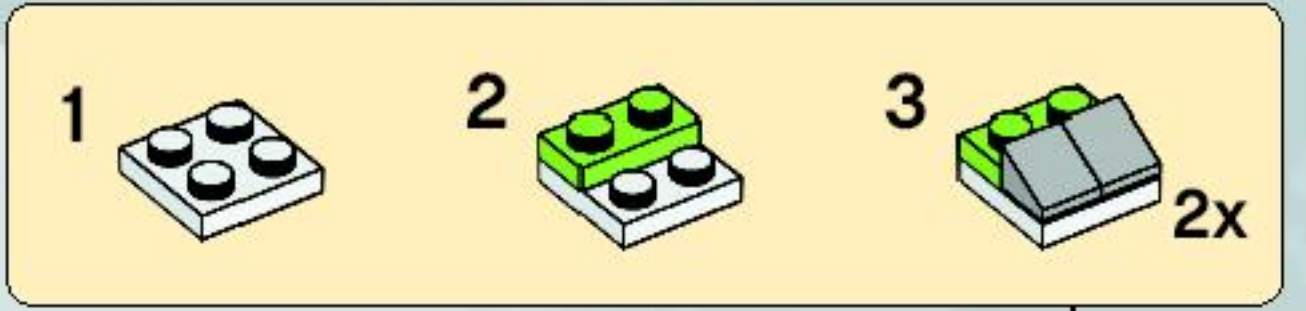
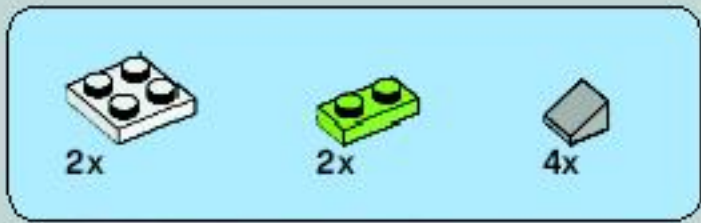

10

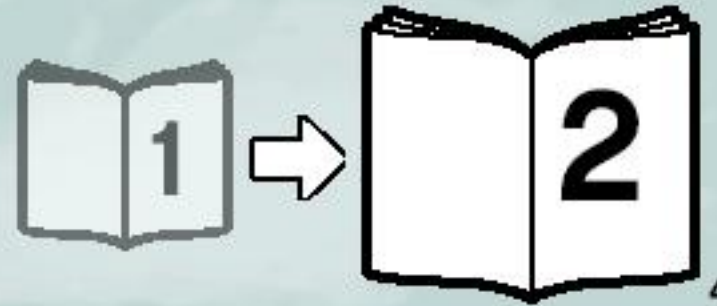
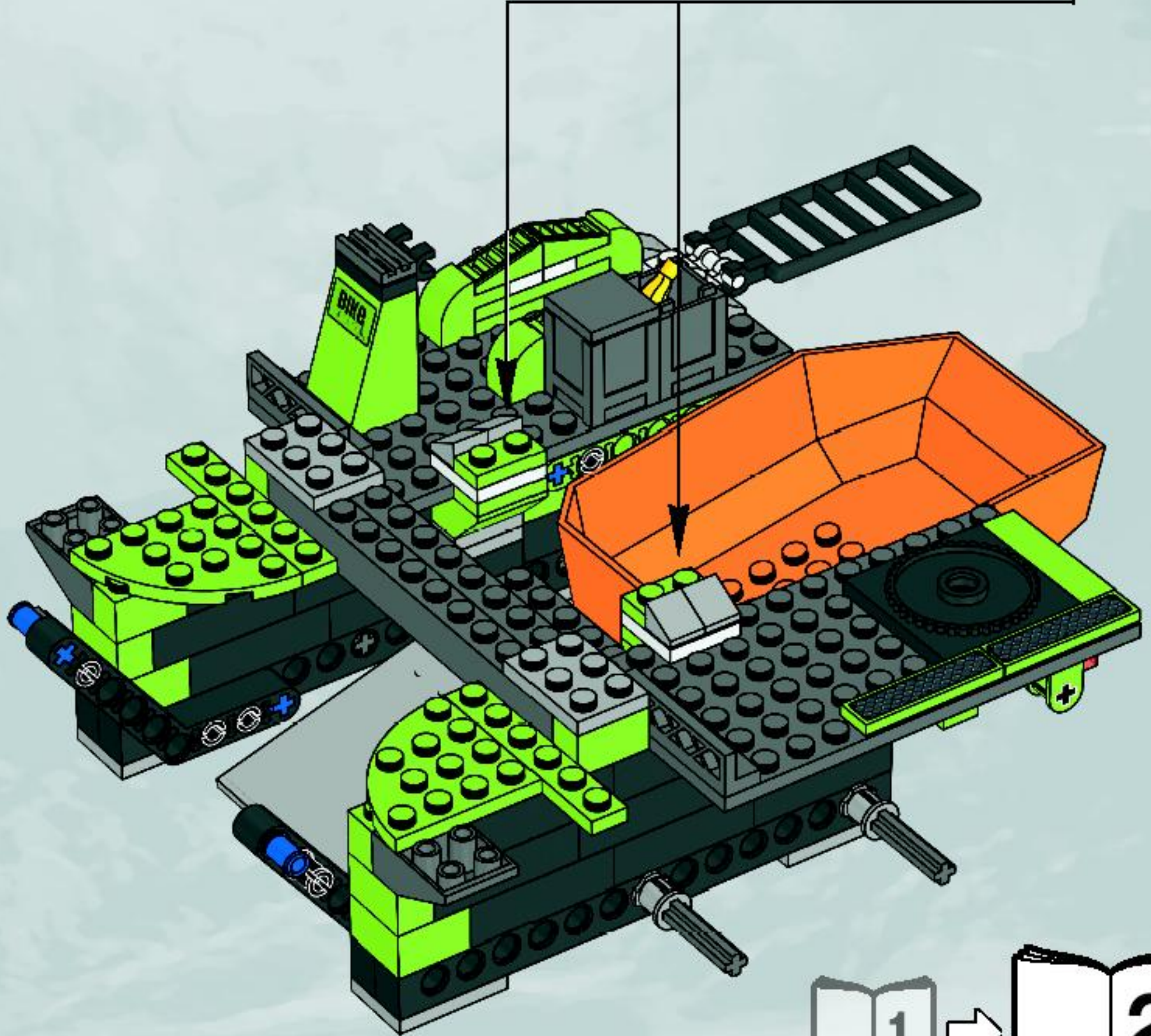

www.nielsen.com/LEGO



WIN LEGO® PRODUCTS

Fill out a survey and you might WIN a cool LEGO product
NO PURCHASE NECESSARY

Open to all residents where not prohibited
Go to www.nielsen.com/dk/LEGO to fill out a survey for a chance to win a LEGO product.

WIN LEGO® PRODUCTEN

Vul een enquêteformulier in en maak kans op een cool LEGO® product
Kopen niet nodig
Iedereen uit landen waar geen enquêteverbod geldt mag deelnemen.
Ga naar www.nielsen.com/dk/LEGO, vul een enquêteformulier in en maak kans op een LEGO product.

GEWINNE LEGO® PRODUKTE

Nimm an der Umfrage teil und GEWINNE ein tolles LEGO® Produkt!
Die Teilnahme am Gewinnspiel führt zu keinerlei Kaufverpflichtungen
Teilnahme in allen nicht ausgeschlossenen Ländern möglich
Wir verlosen unter allen Teilnehmern der Umfrage auf www.nielsen.com/dk/LEGO LEGO Produkte.

GAGNE DES PRODUITS LEGO®

Réponds à un questionnaire et tu pourrais GAGNER un produit LEGO® très cool !
Aucune obligation d'achat.
Ouvert à tous les résidents des pays autorisés.
Visite www.nielsen.com/dk/LEGO pour répondre à un questionnaire et avoir une chance de gagner un produit LEGO.

レゴ®製品を「当てよう」

アンケートに記入して、かっこいいレゴ®製品を当てよう！
お買い上げの必要はありません。
禁止されていない限り、すべての皆様にご利用いただけます。
www.nielsen.com/dk/LEGOにアクセスして、アンケートにご記入ください。当選者にはレゴ®製品を差し上げます。



©2009 The LEGO Group. 4549565