



RACERS

8645



MUSCLE SLAMMER BIKE

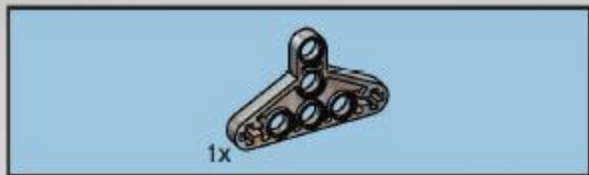

2

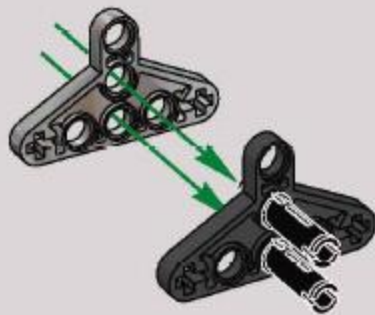

3





4

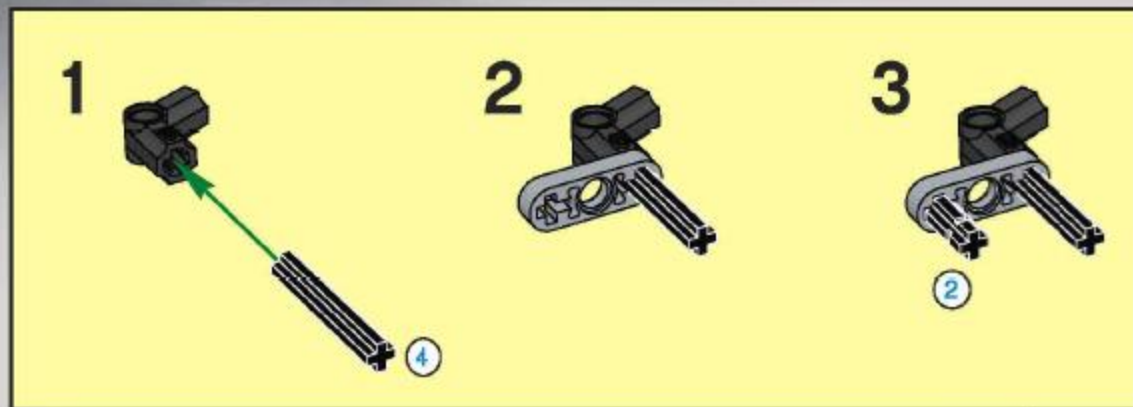

4

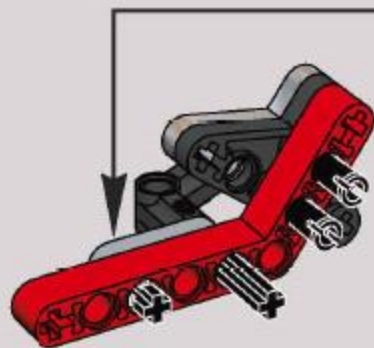



5

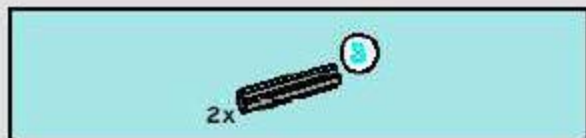
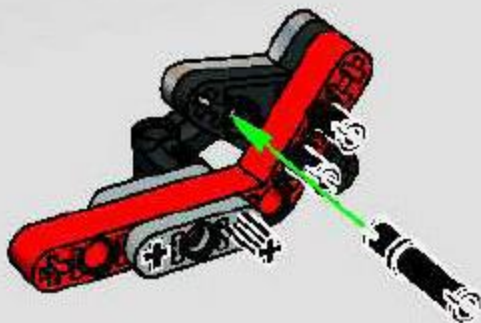

6

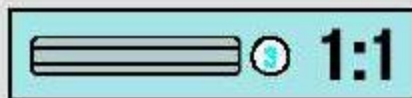
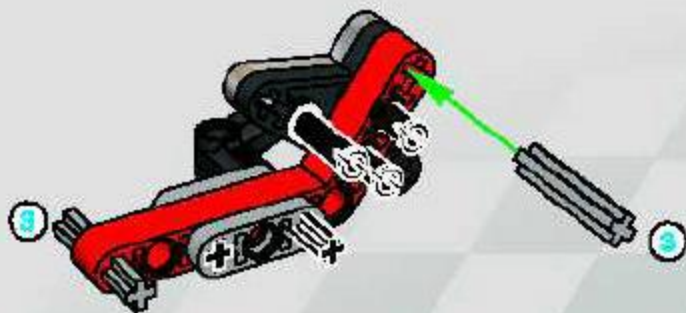



7

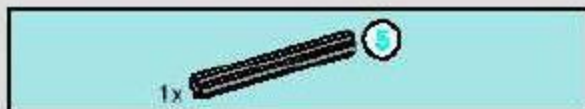

8



6

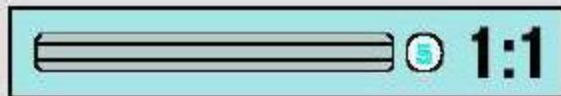



1x

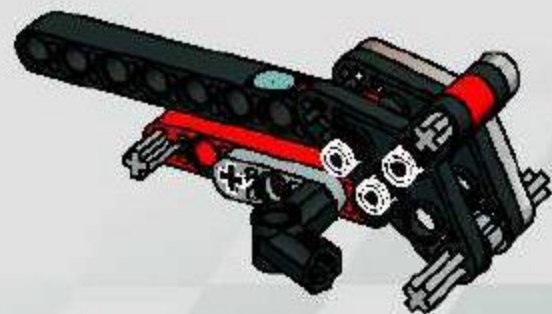
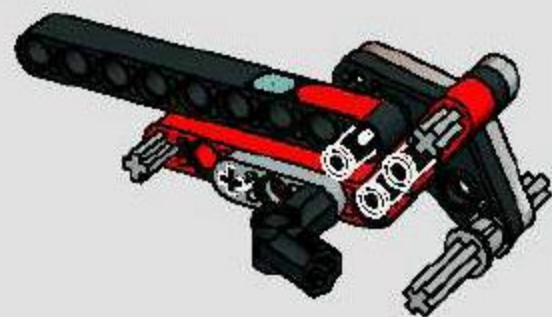

1x



11

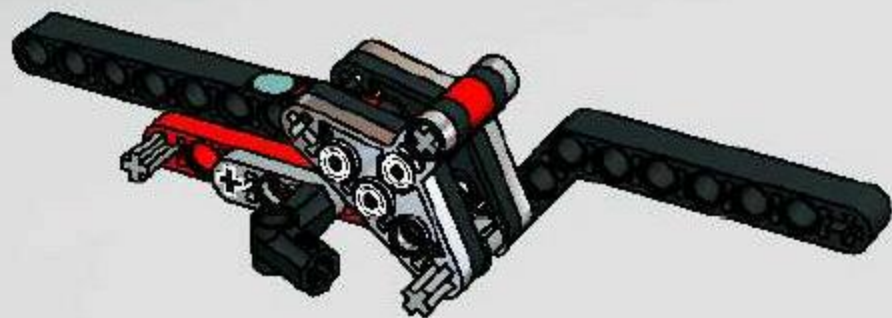



12

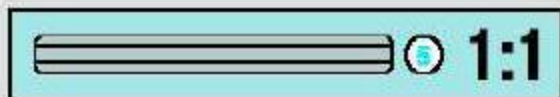
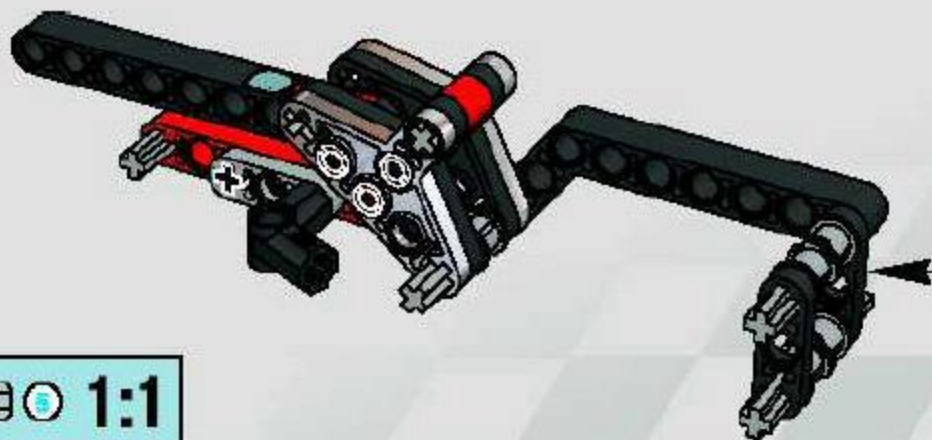
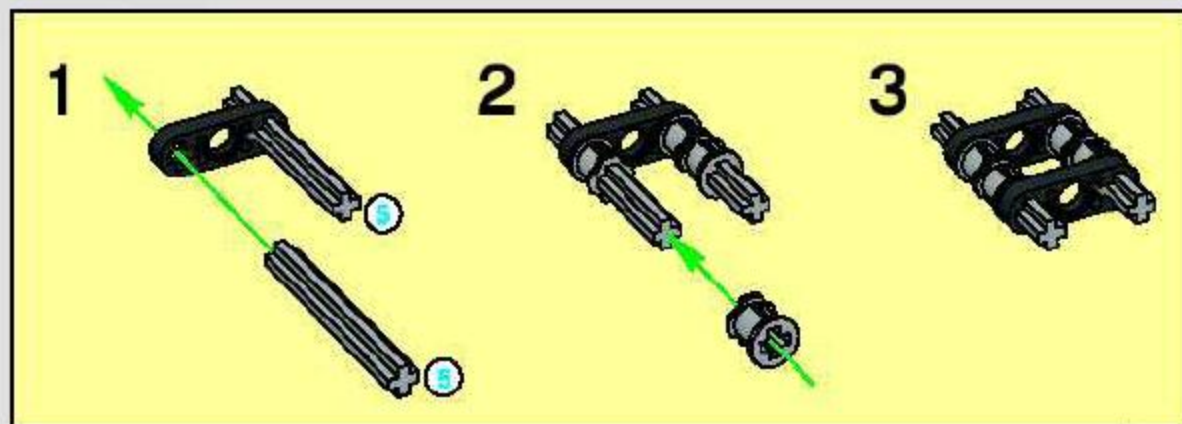

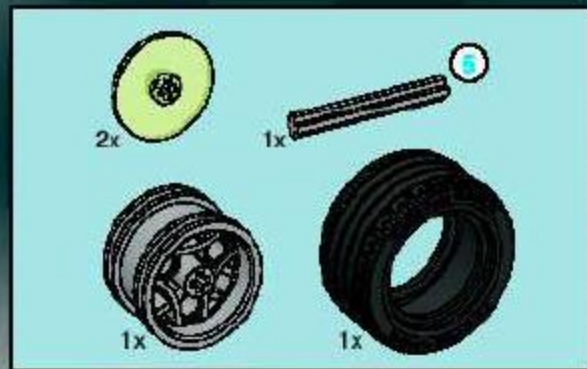

13

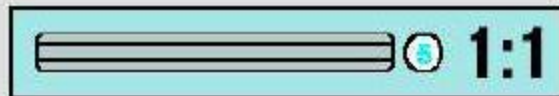
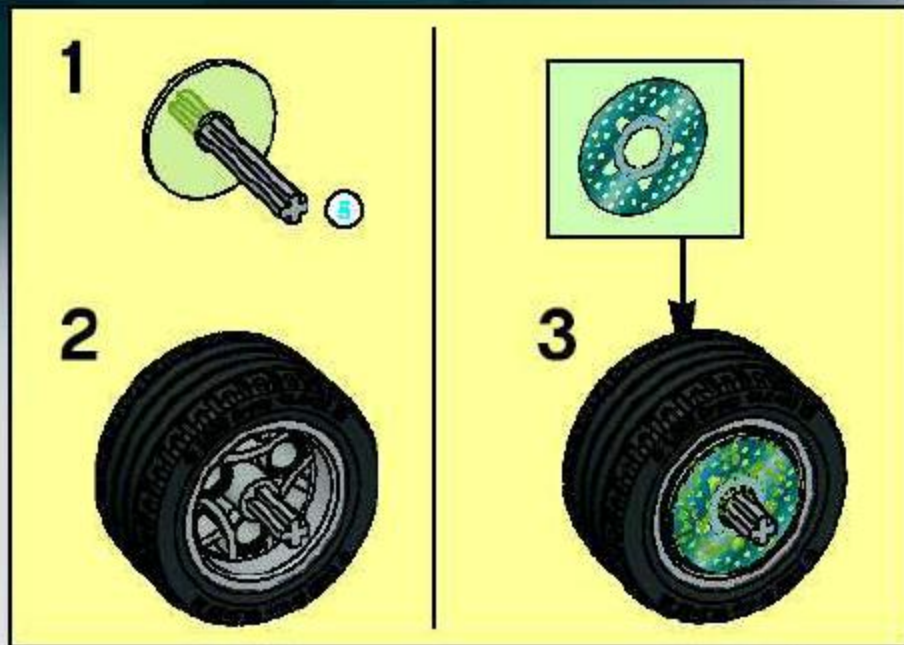

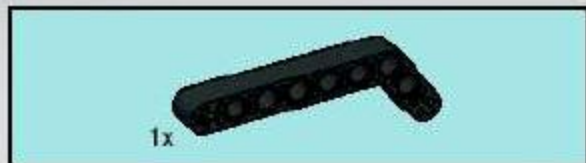

14

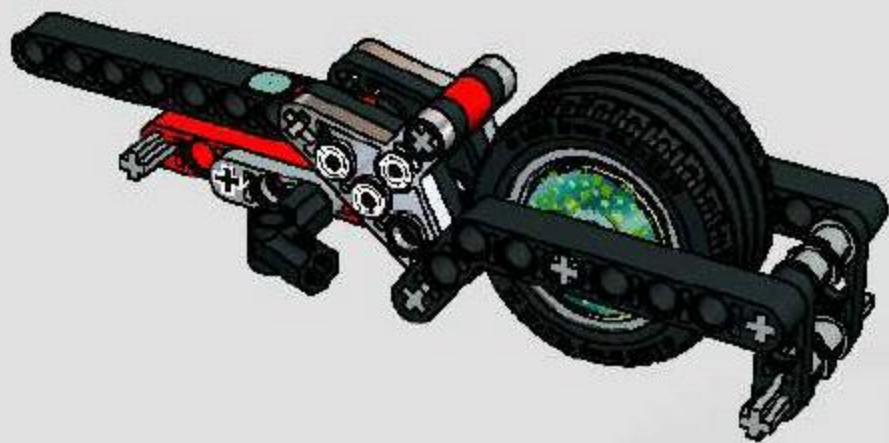



2x

15





16



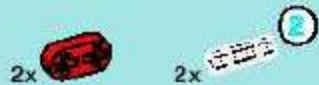

17

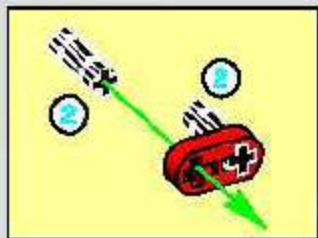

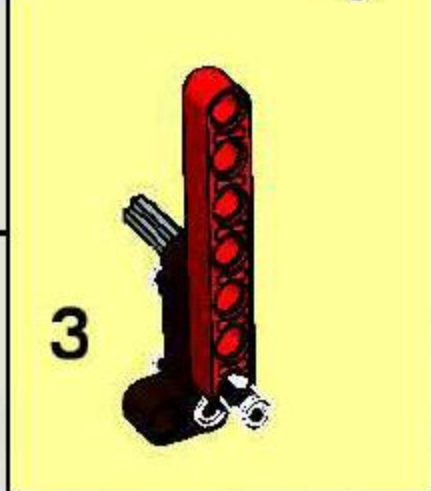
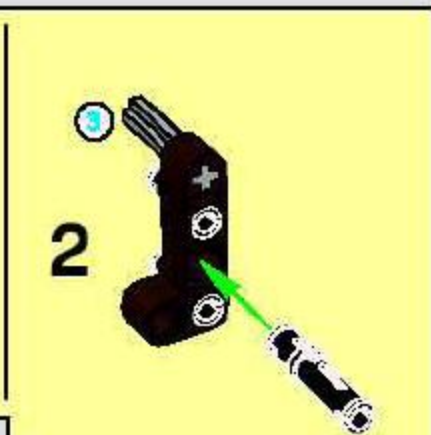
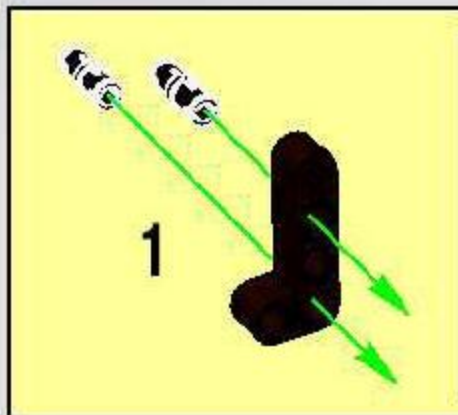
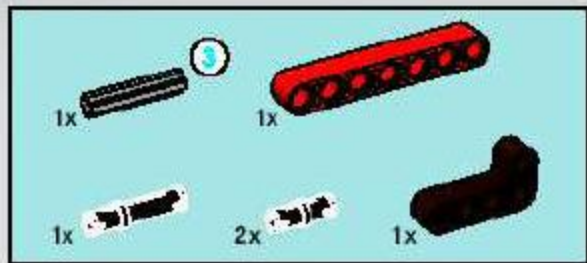

18

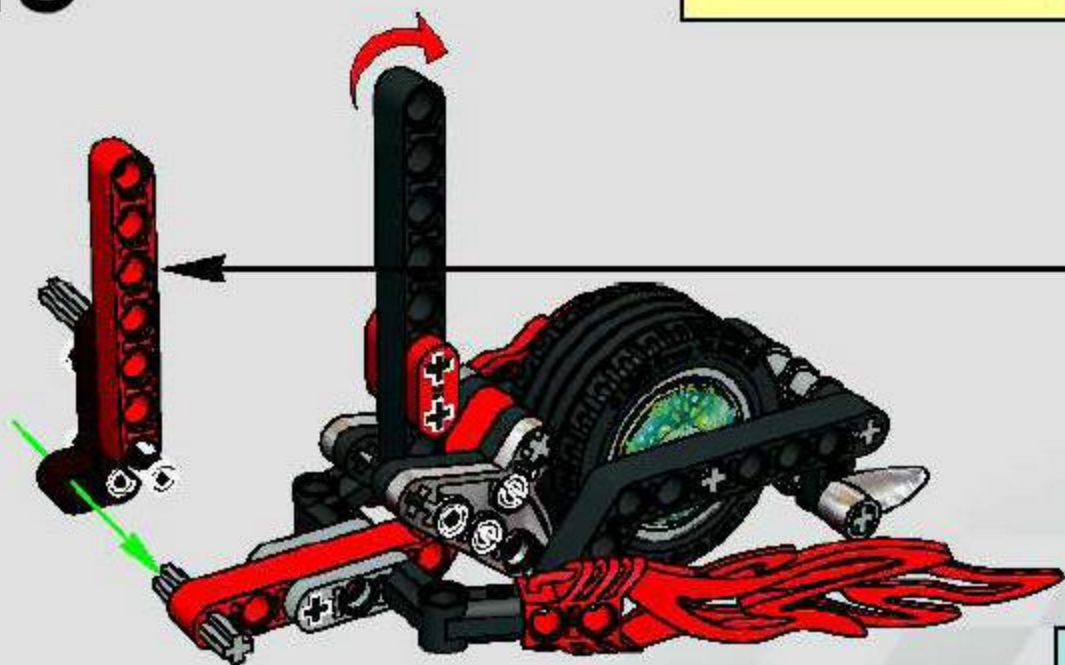



19

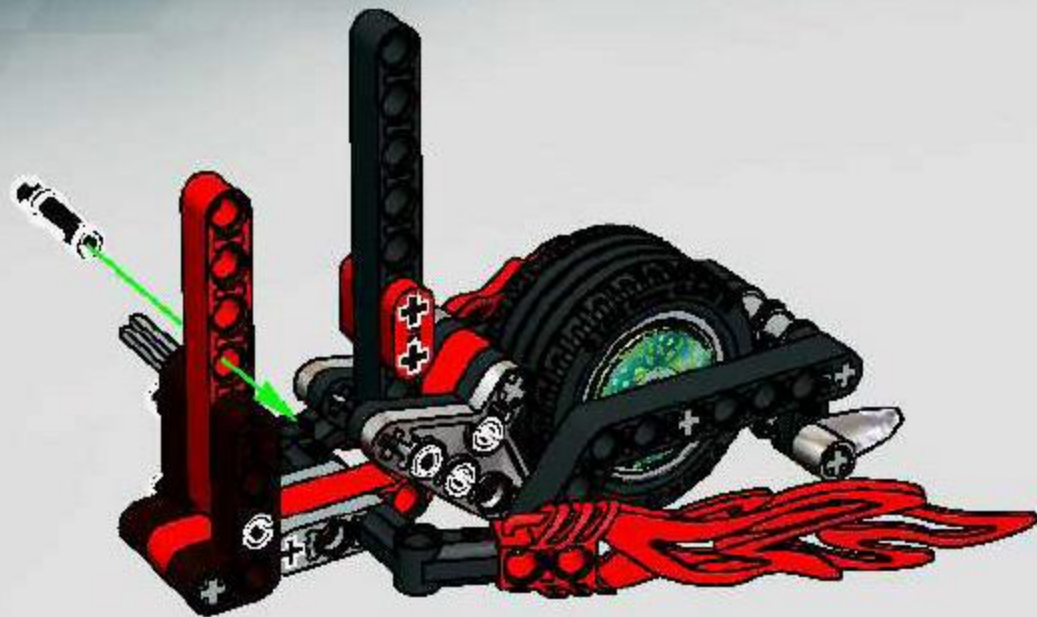

2x

20

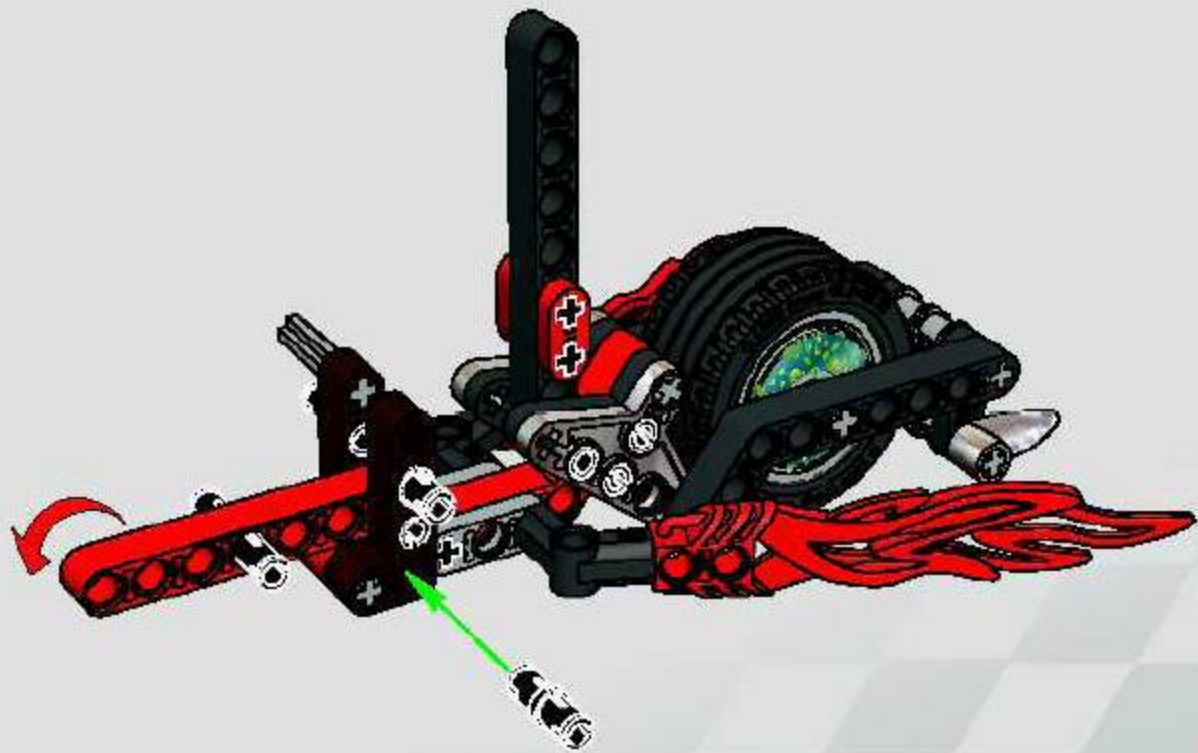

21





22

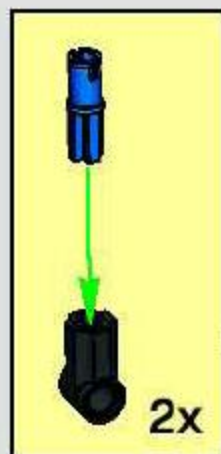

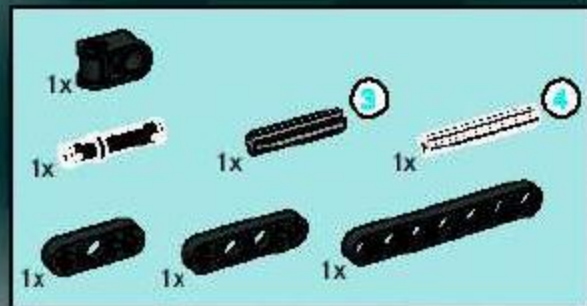

23

1



2

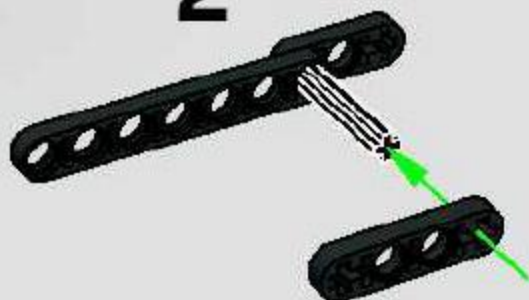

3

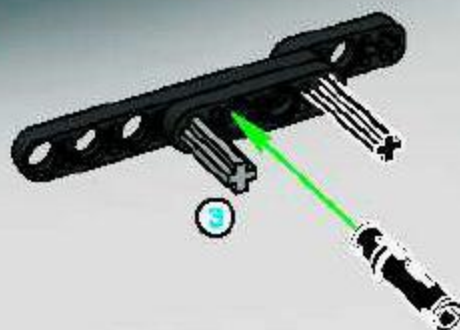

4

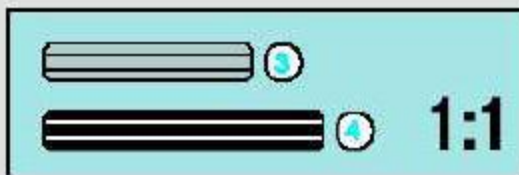

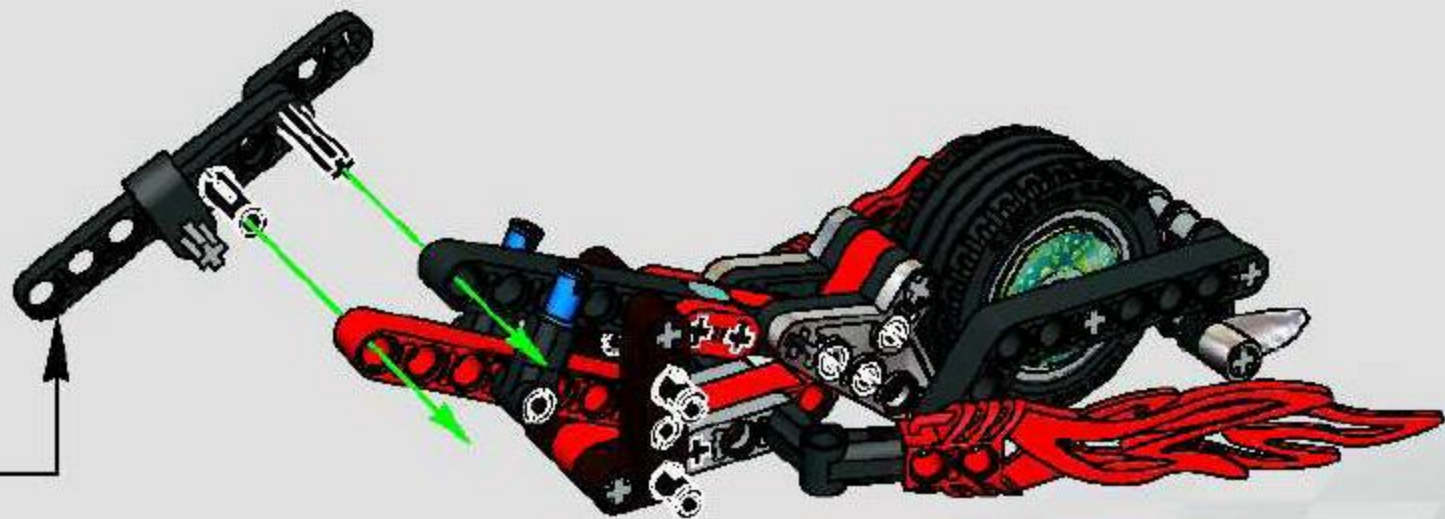



24

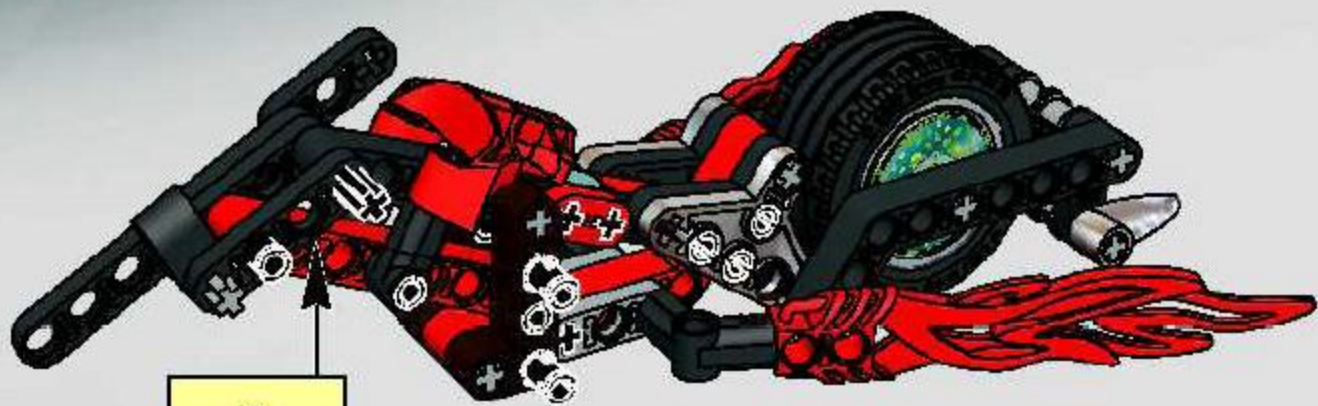

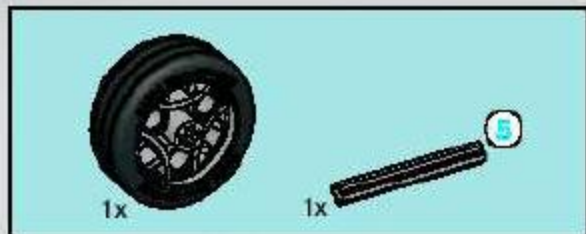

25

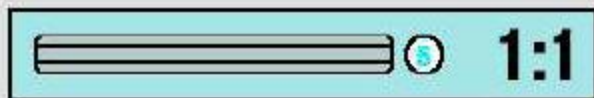
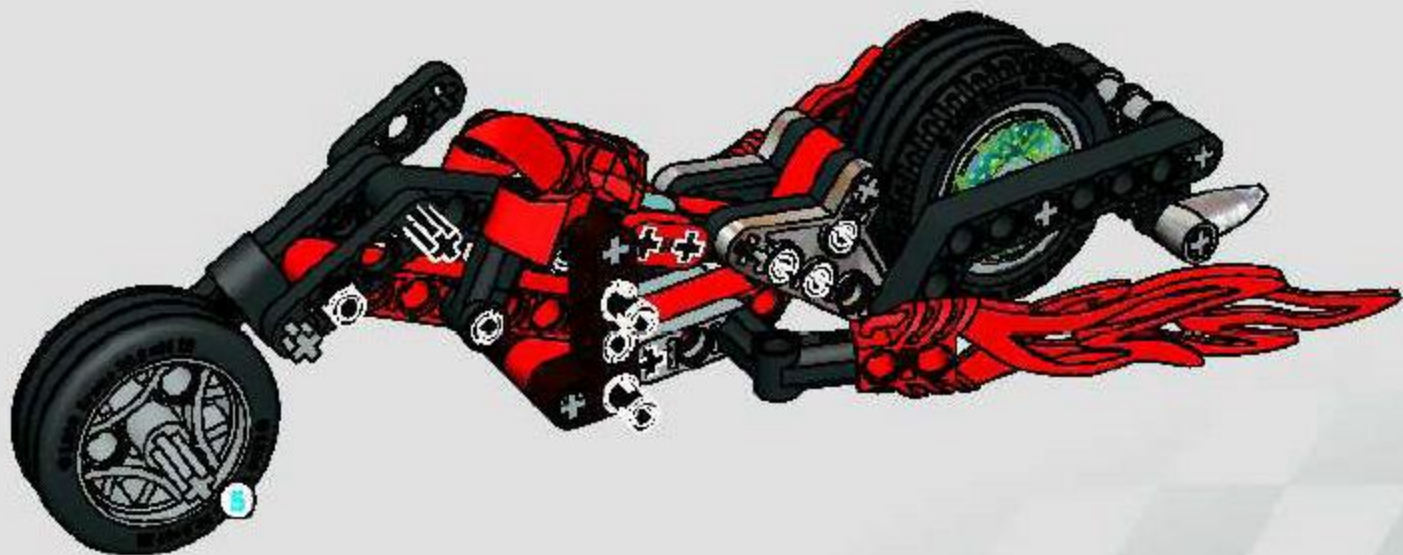



26

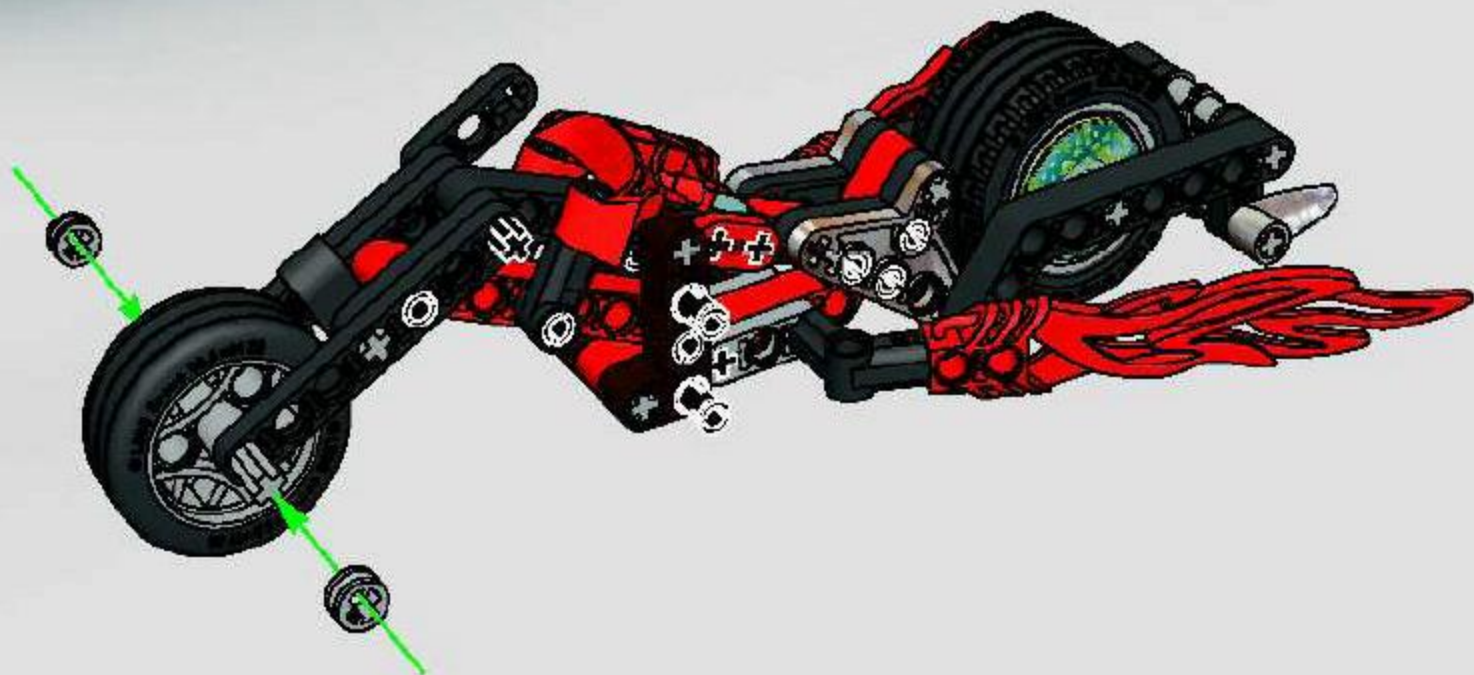

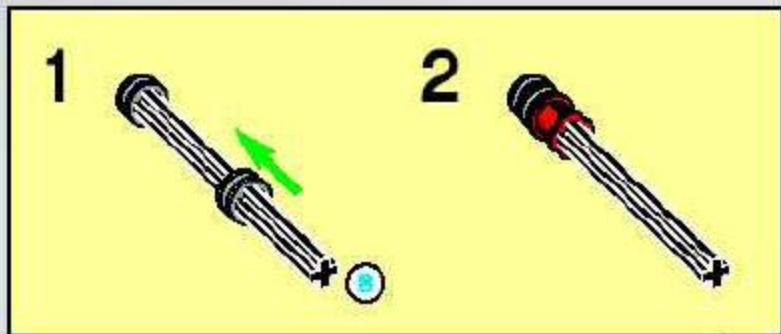
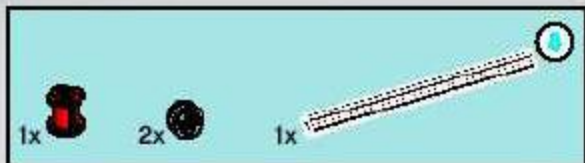

27





1x



1x

28

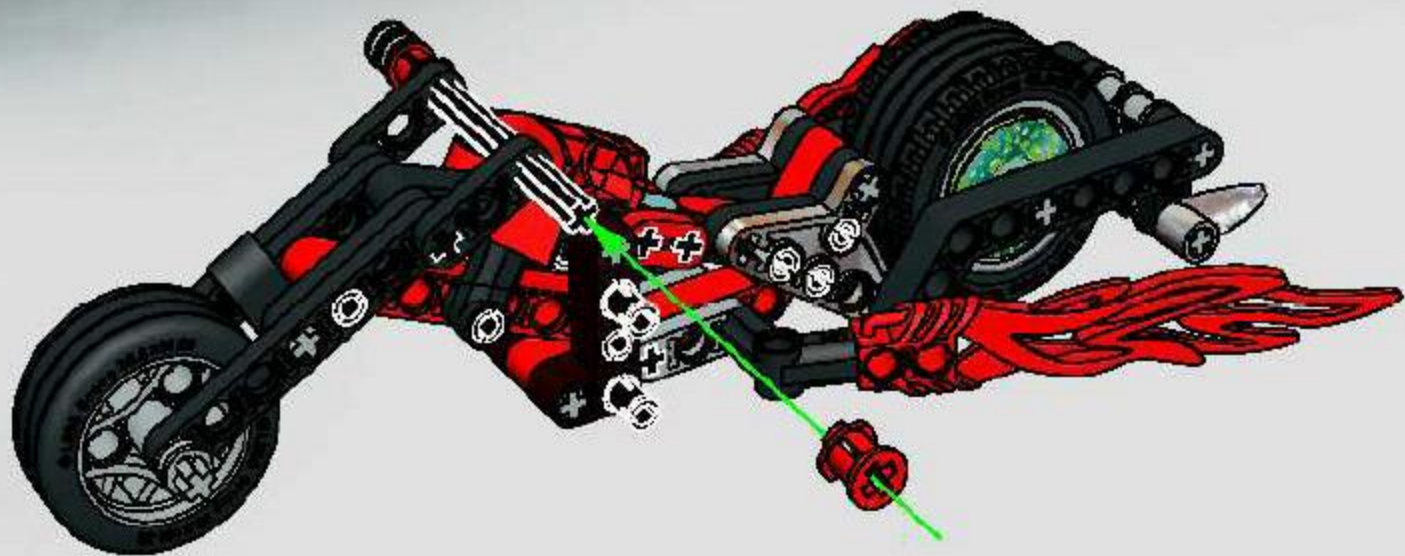

2x 

29

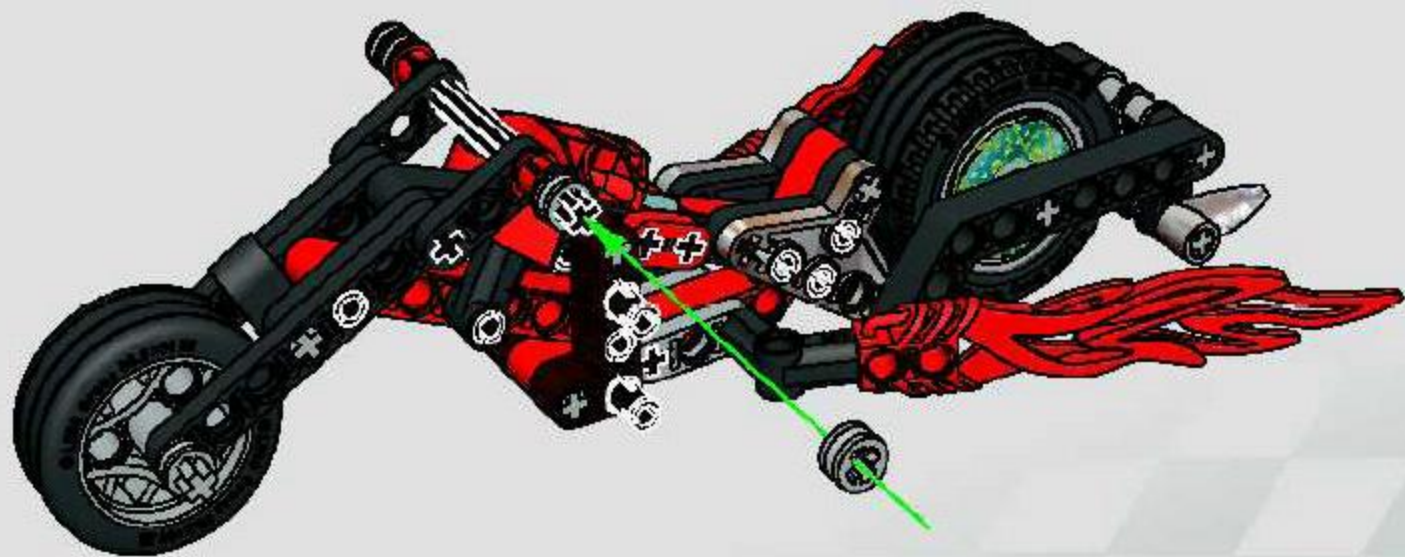



30

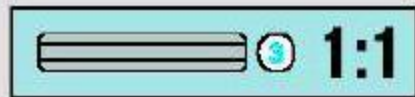
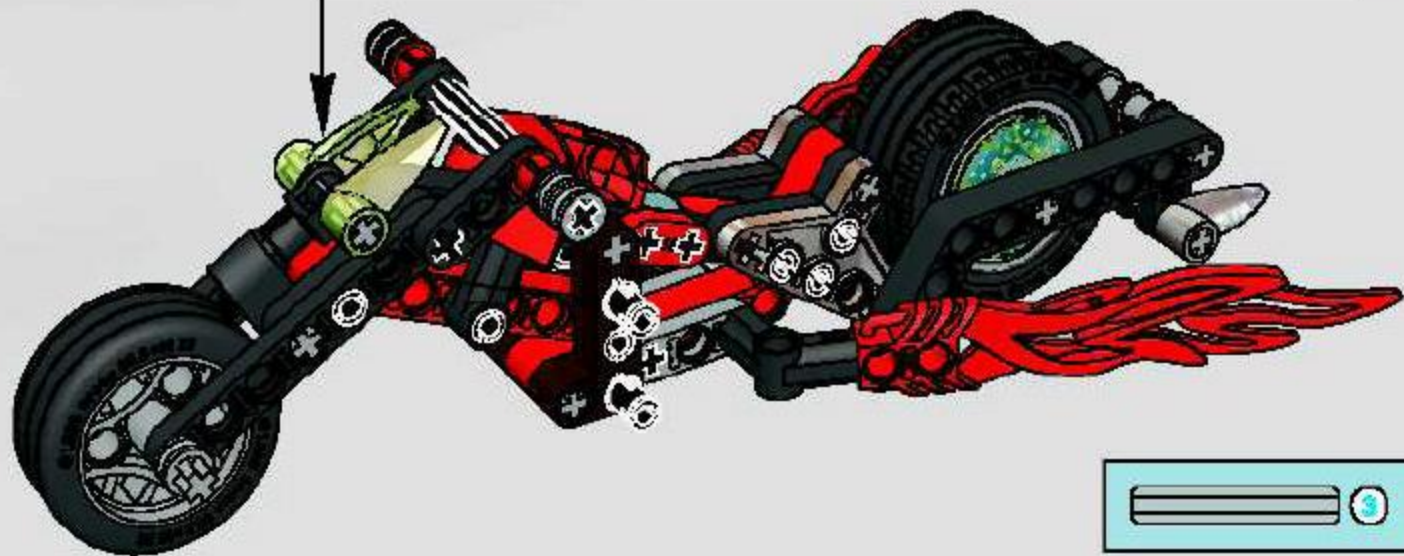



31

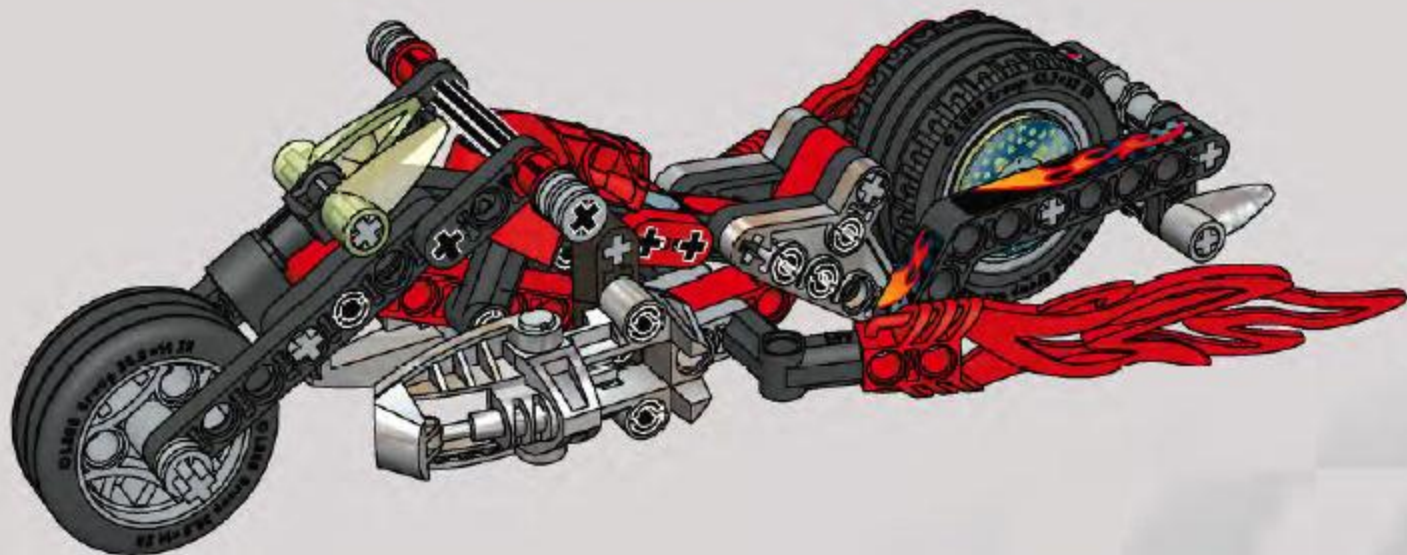



1

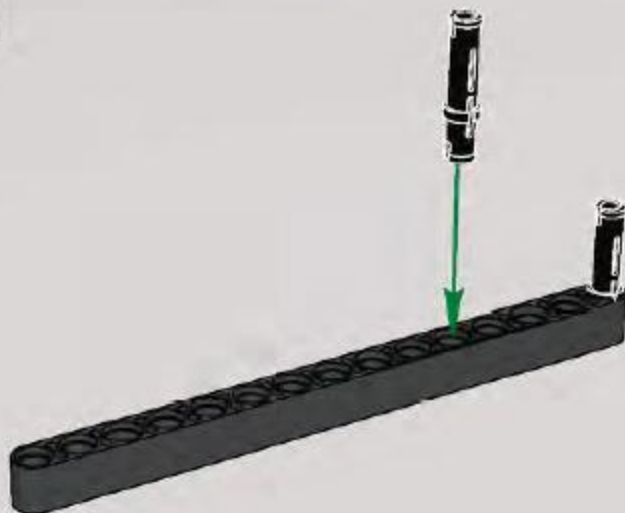



2

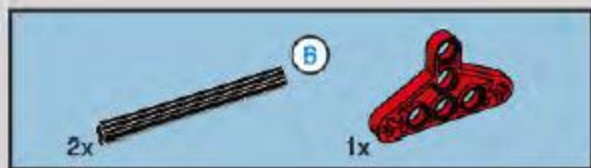
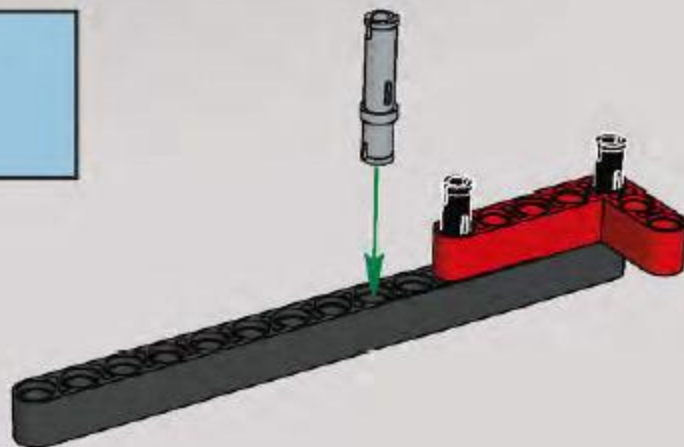

3

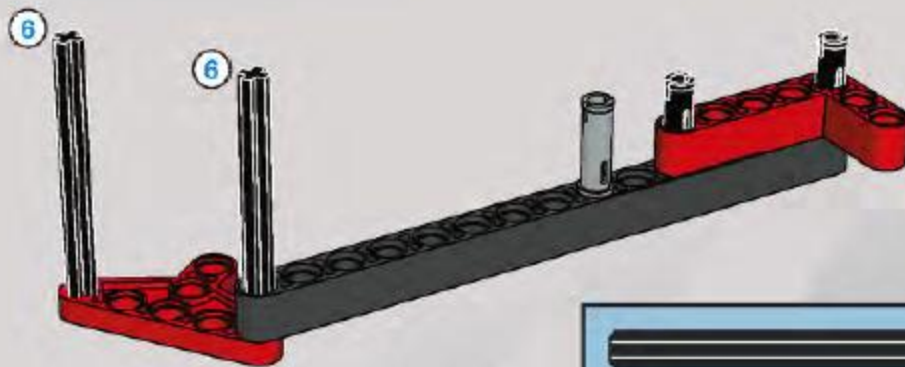

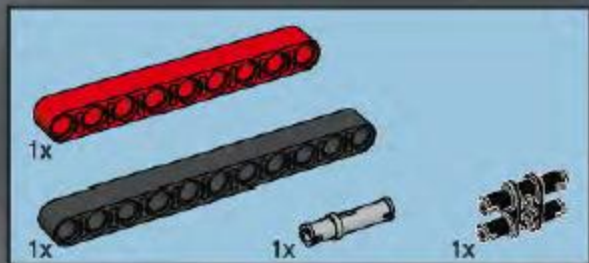

4

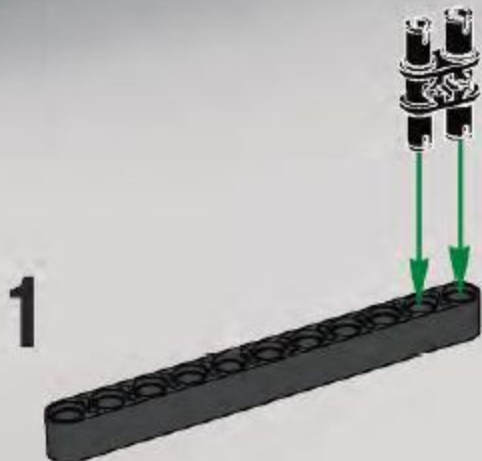

2

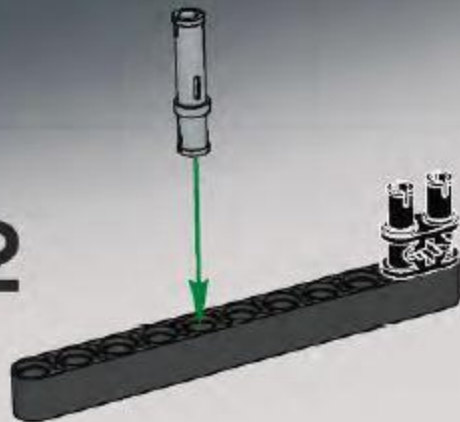

3

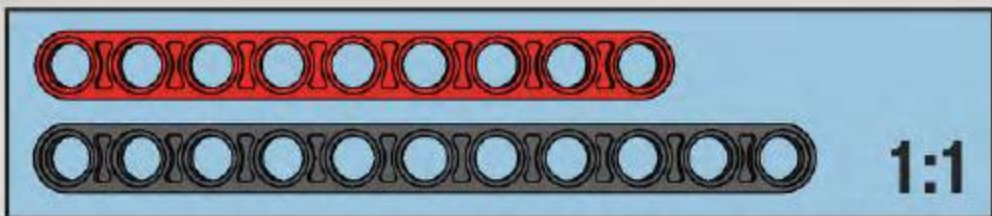
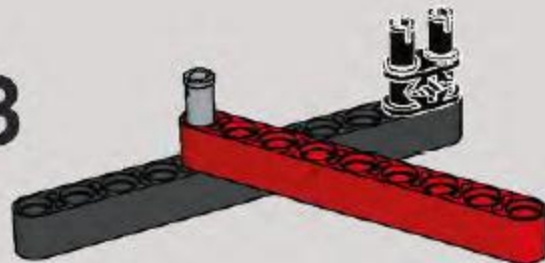

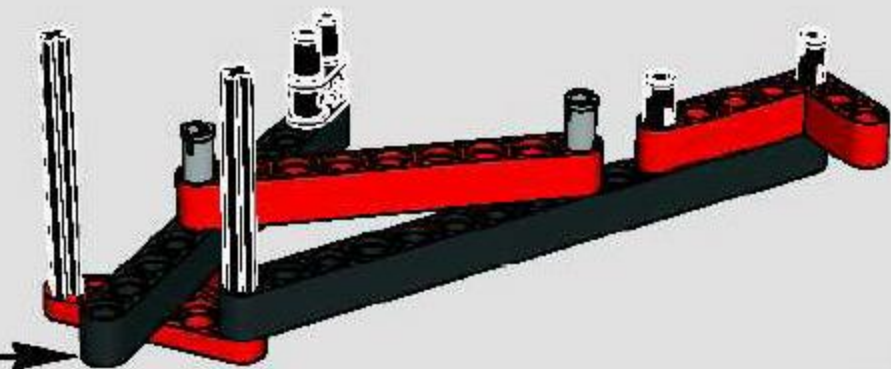

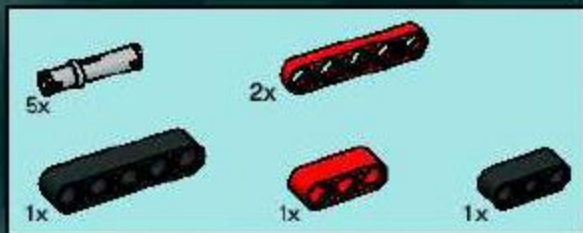

5

1



2

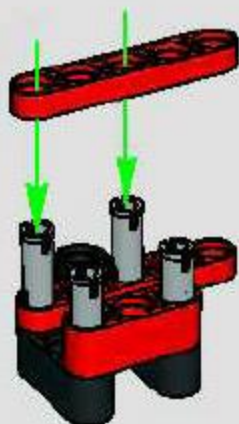

3

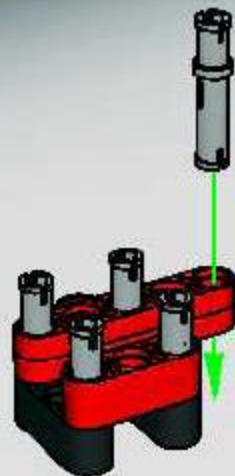

4

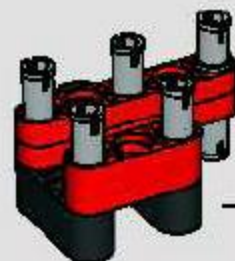

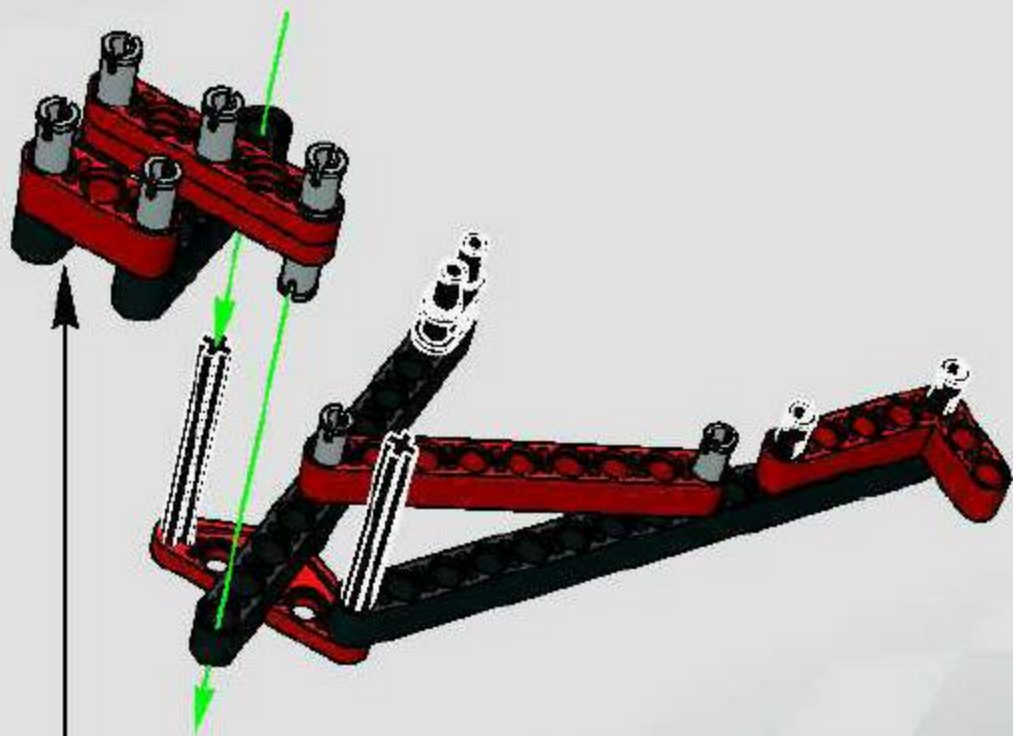

2x



6

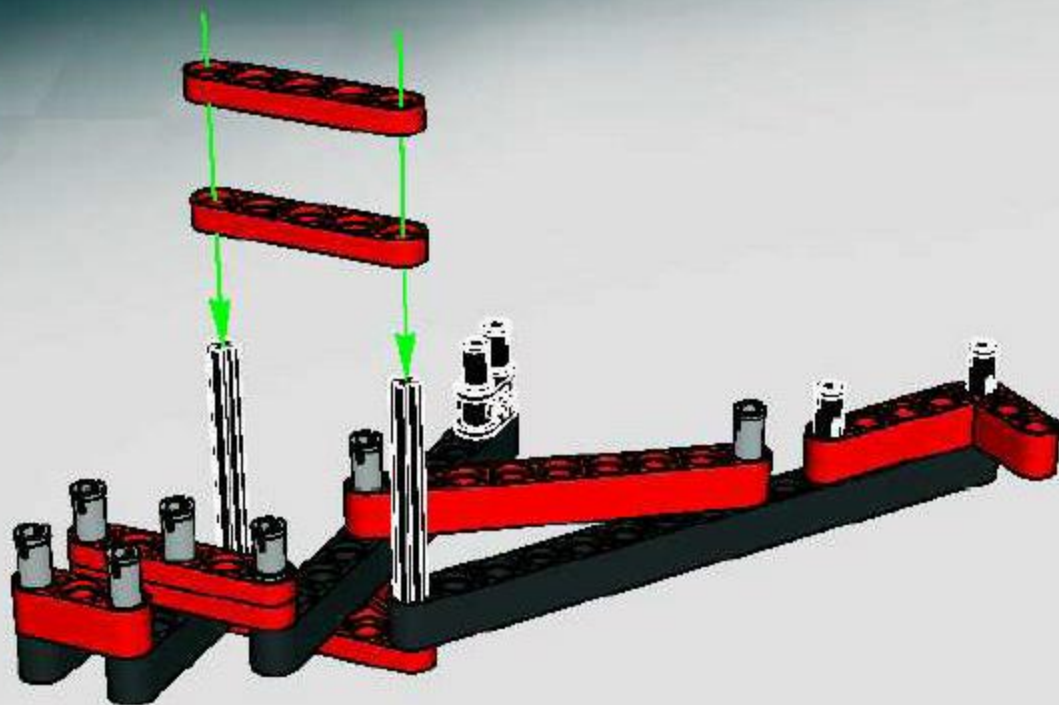



7

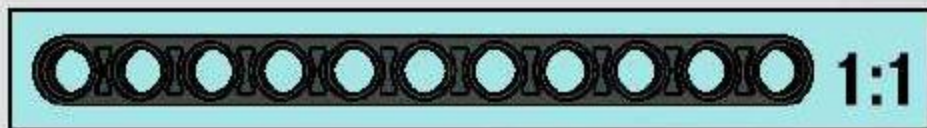
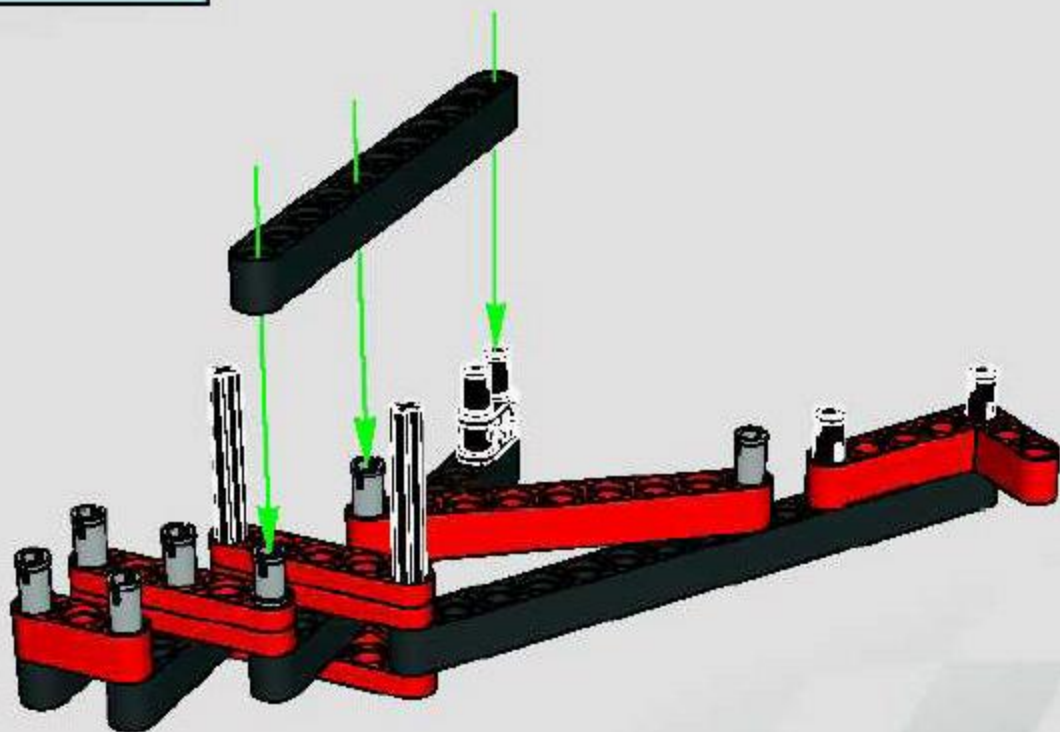



8

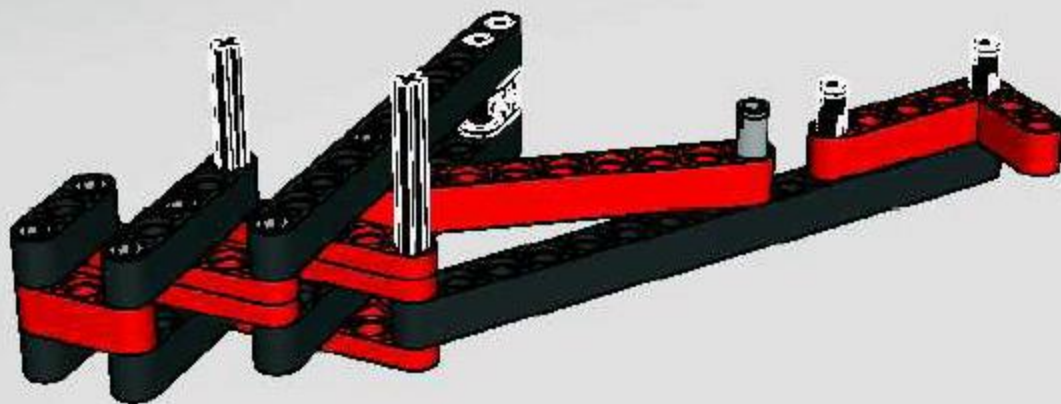



9

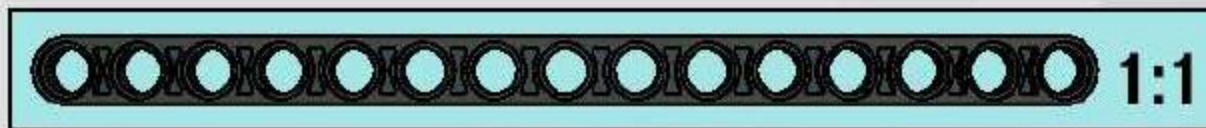
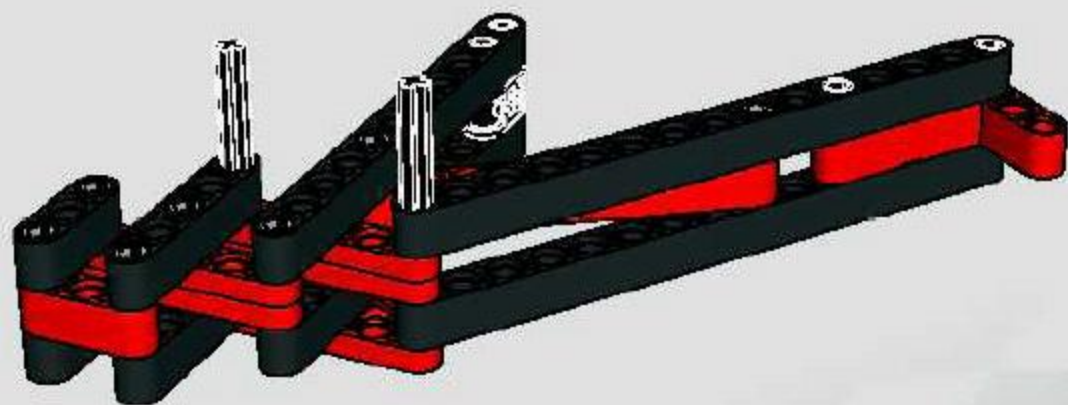



10

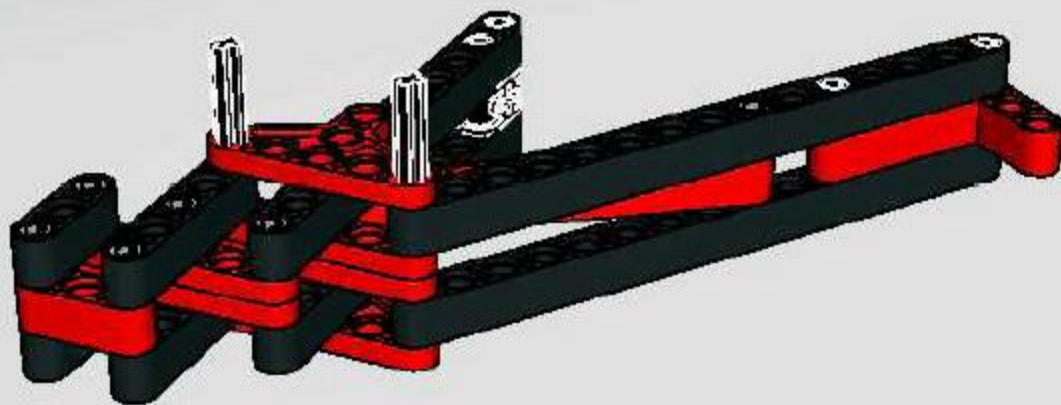



2x



1x

11

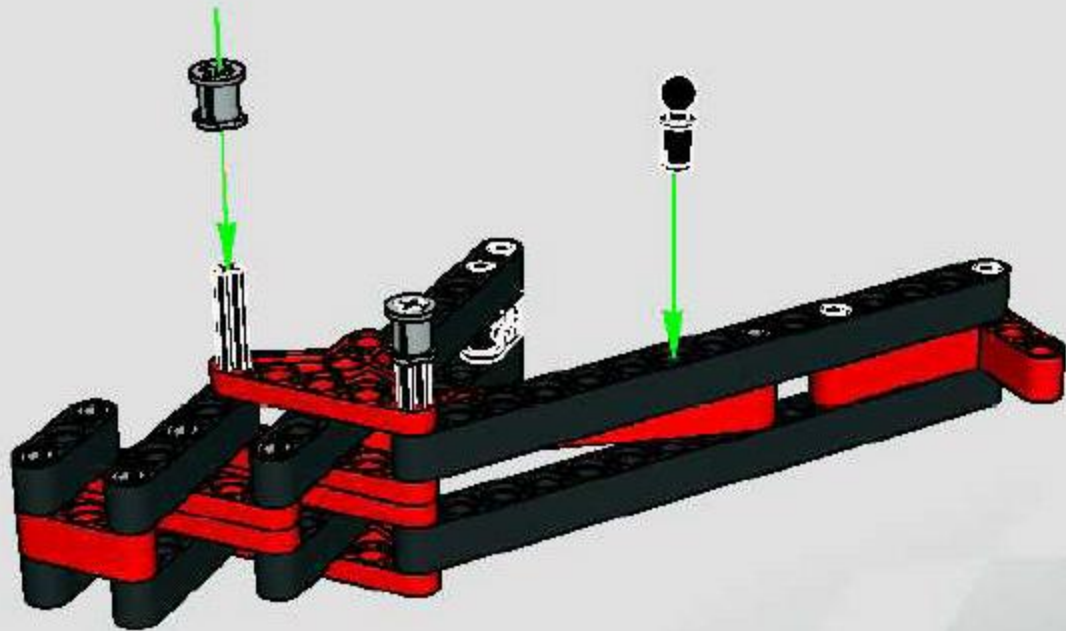

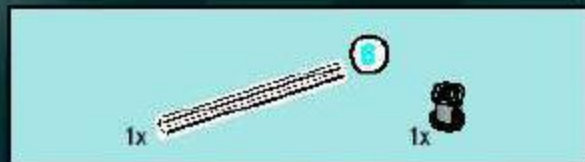

12

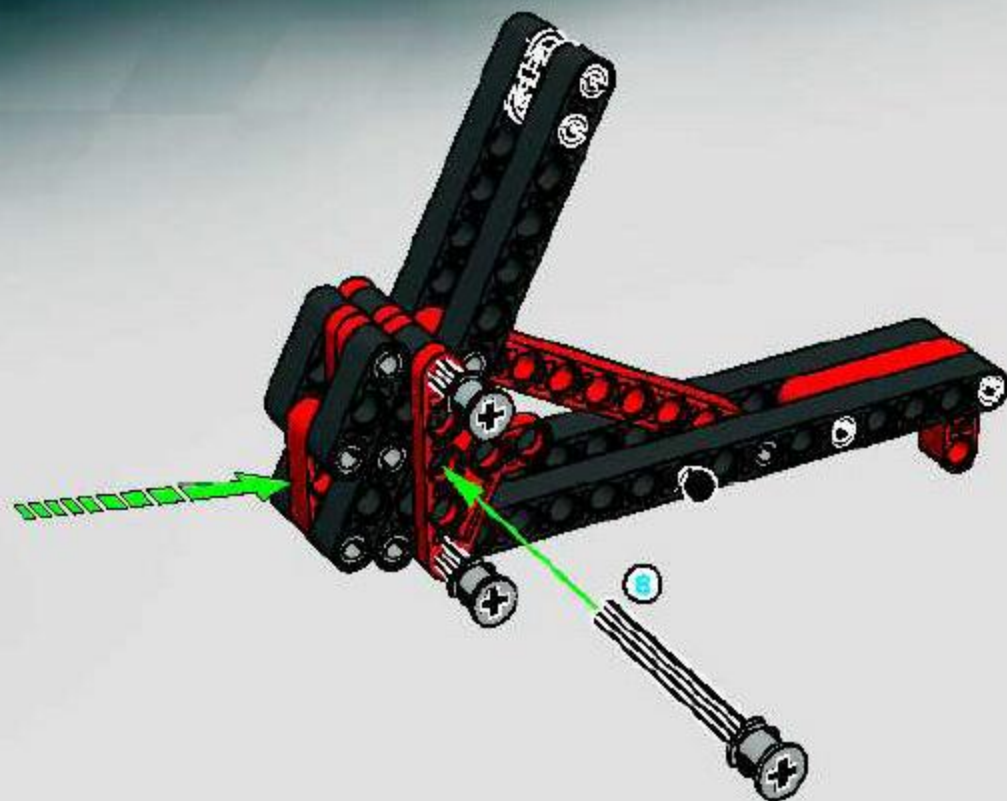

13

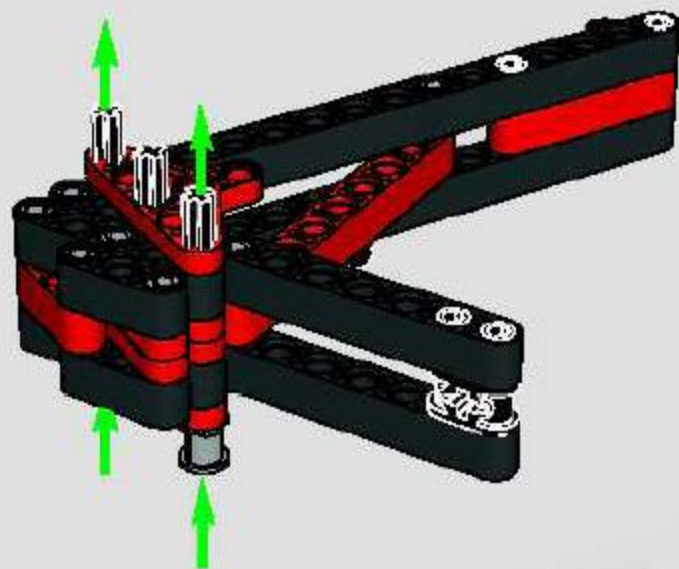



3x



1x

14

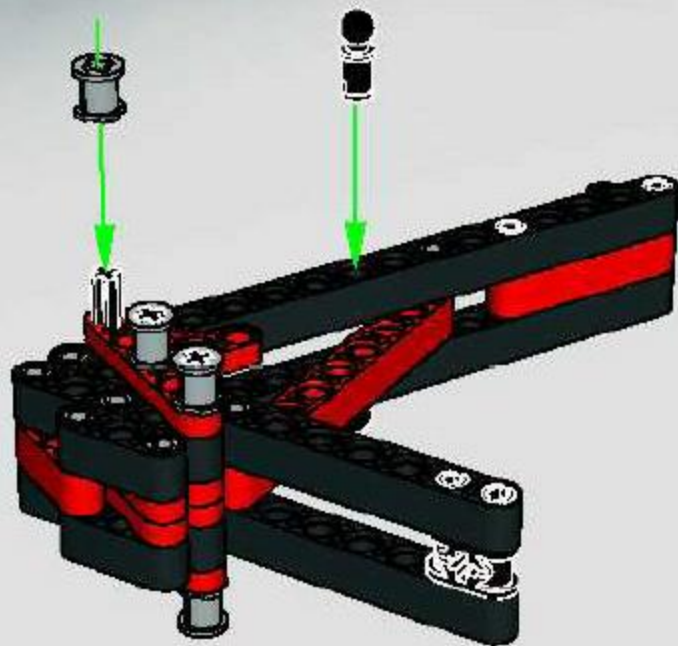

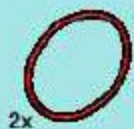

2x

15





8645

+



8646

=



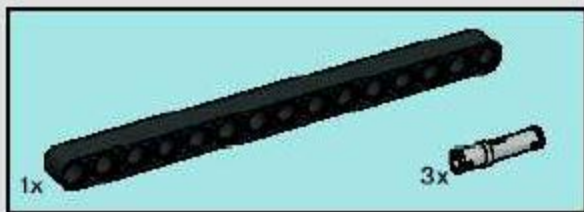
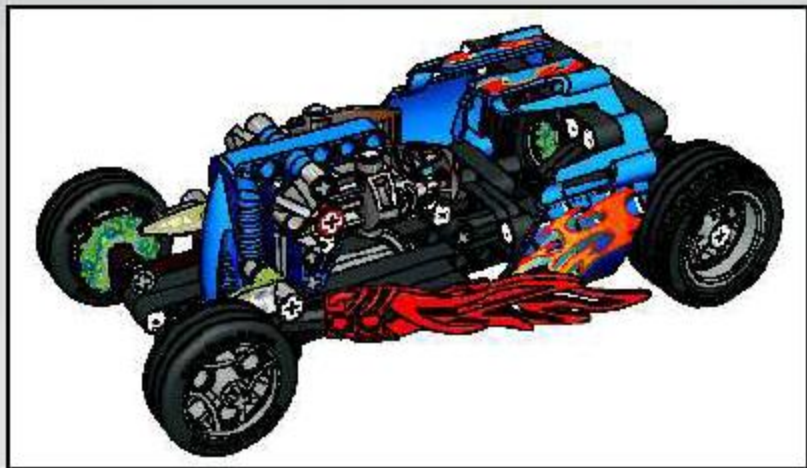

1

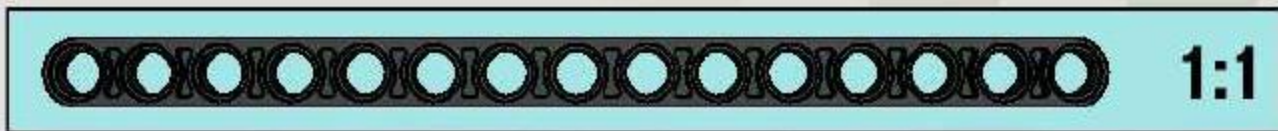



2

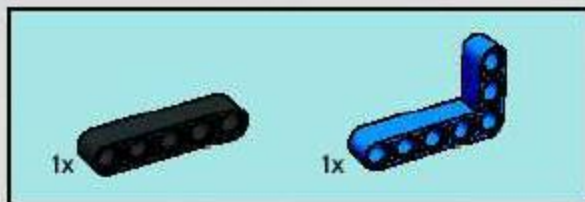
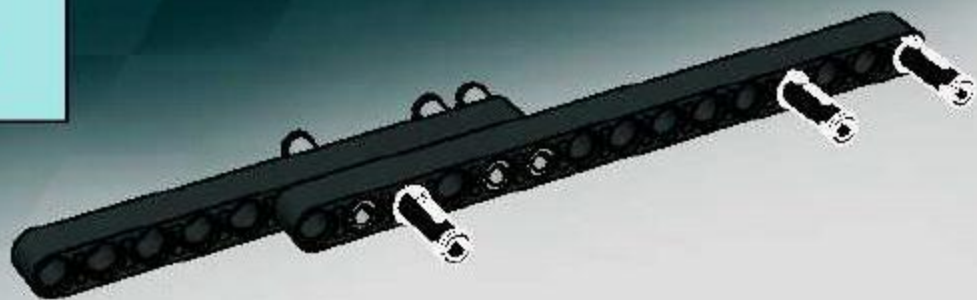

3

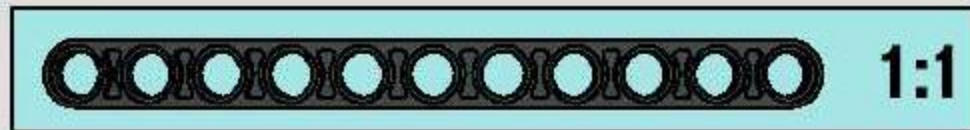
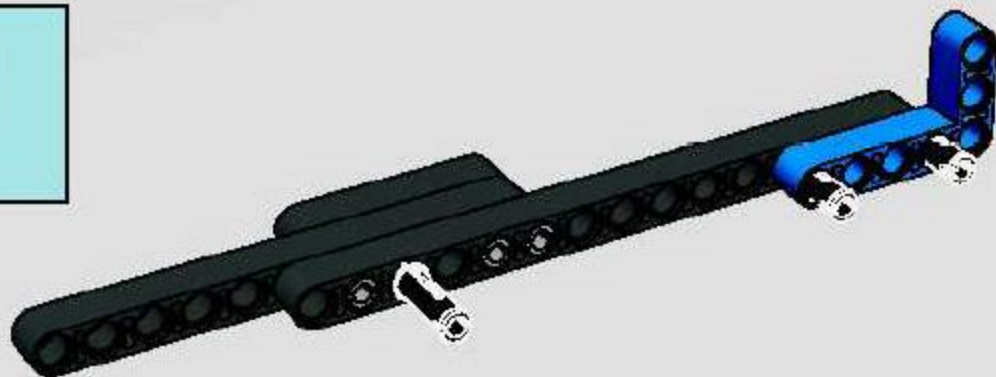

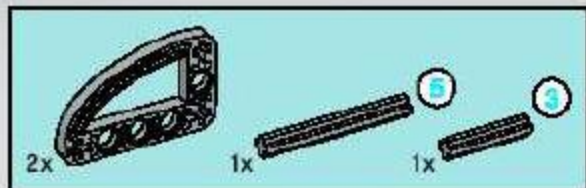

4

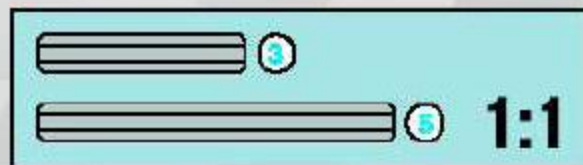
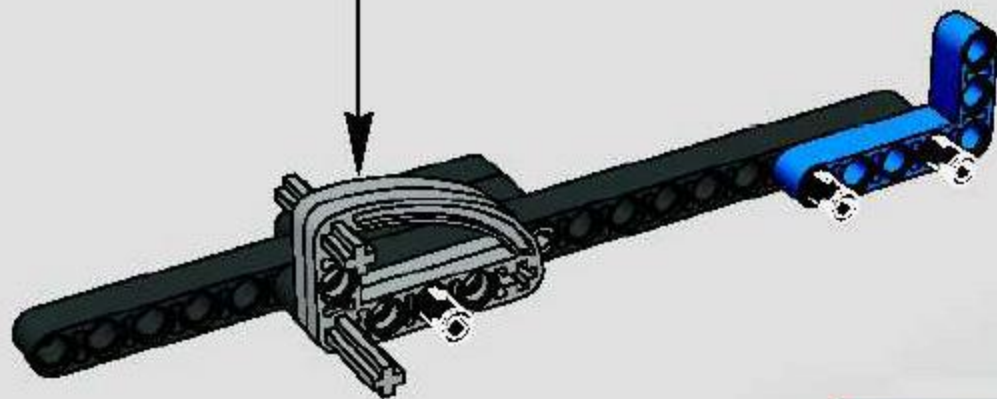
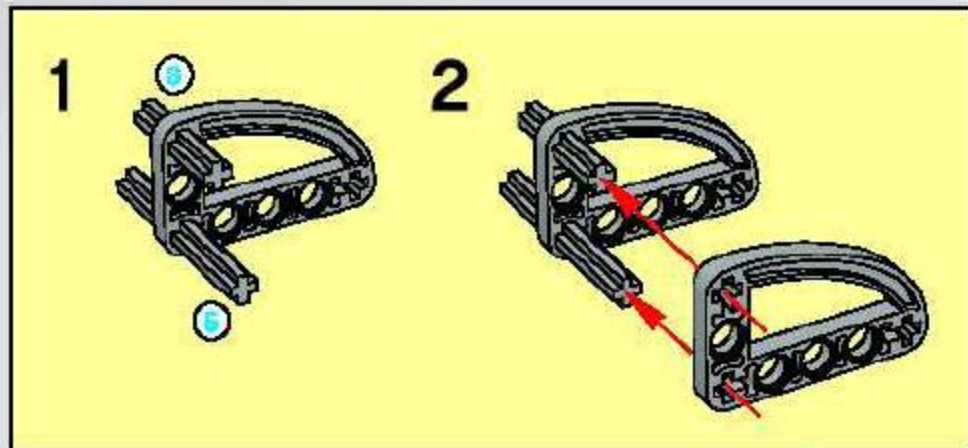



5

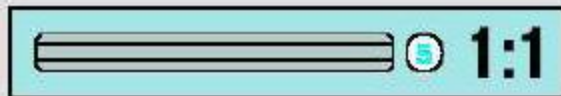
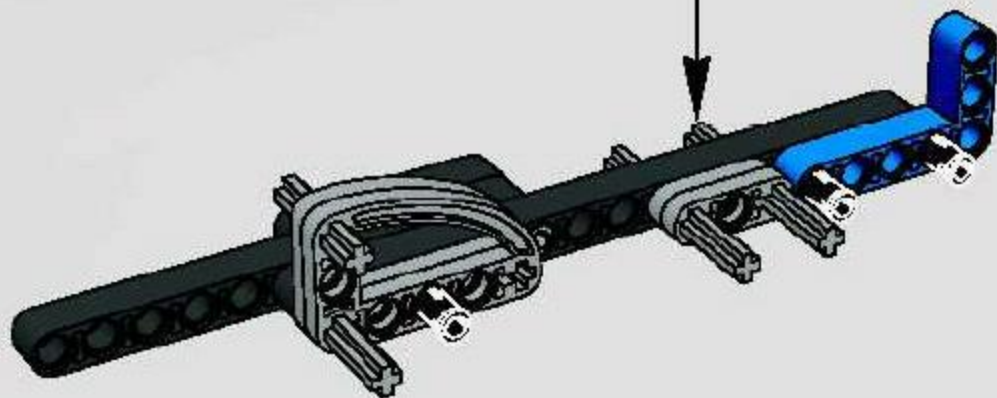
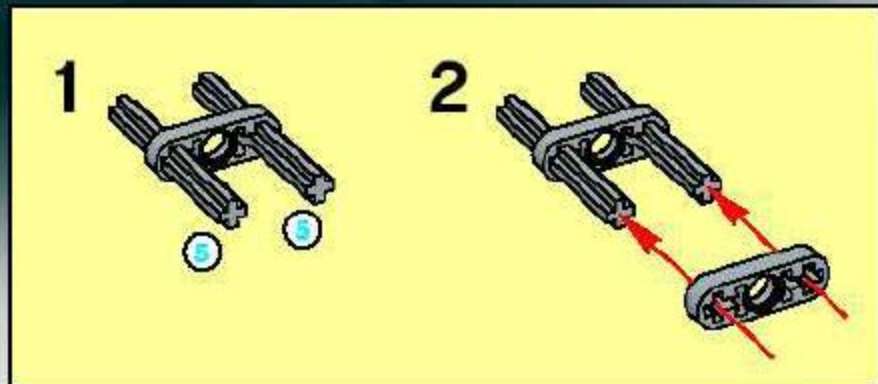

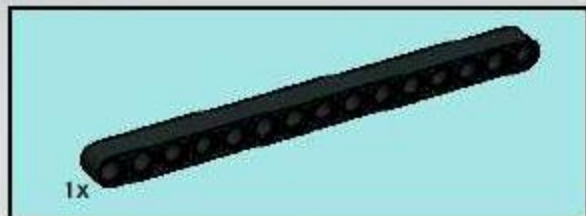

6

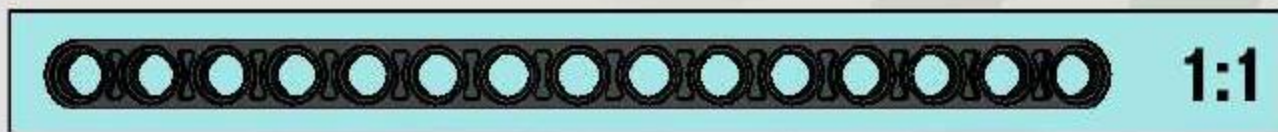
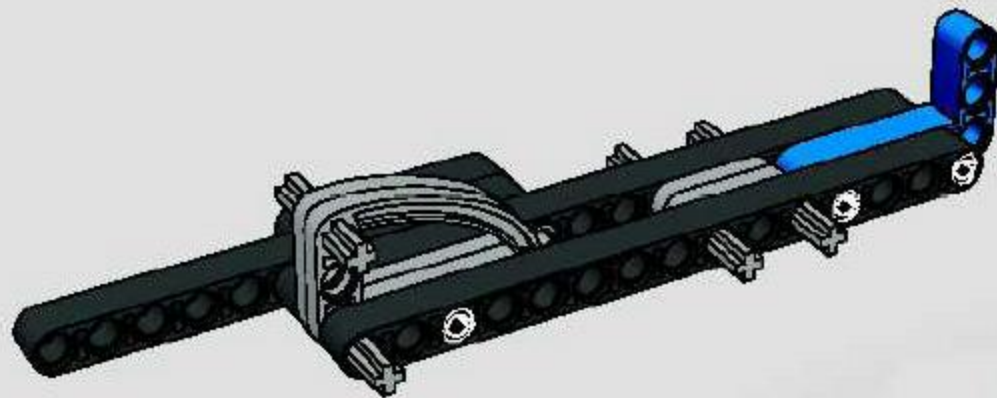



7

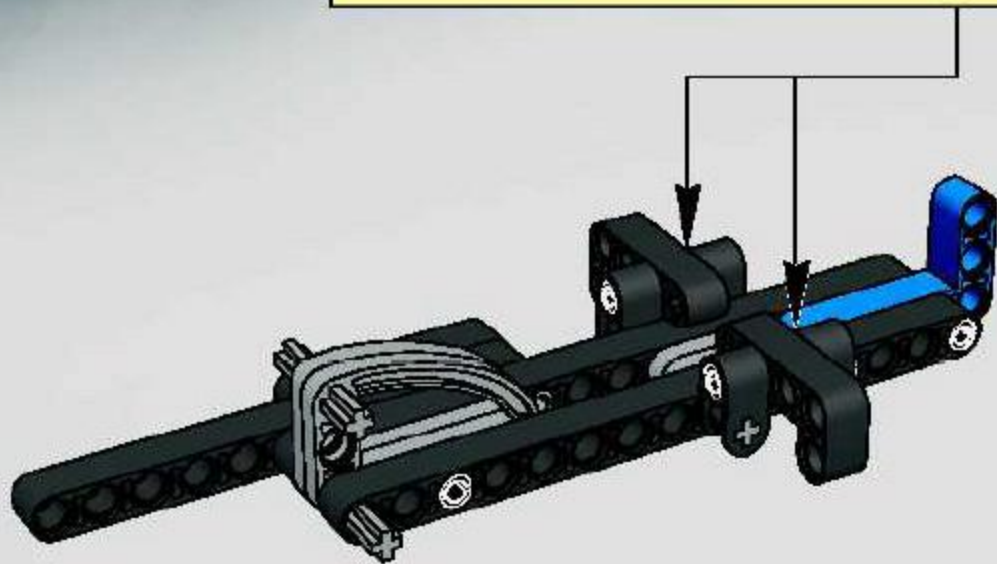



8

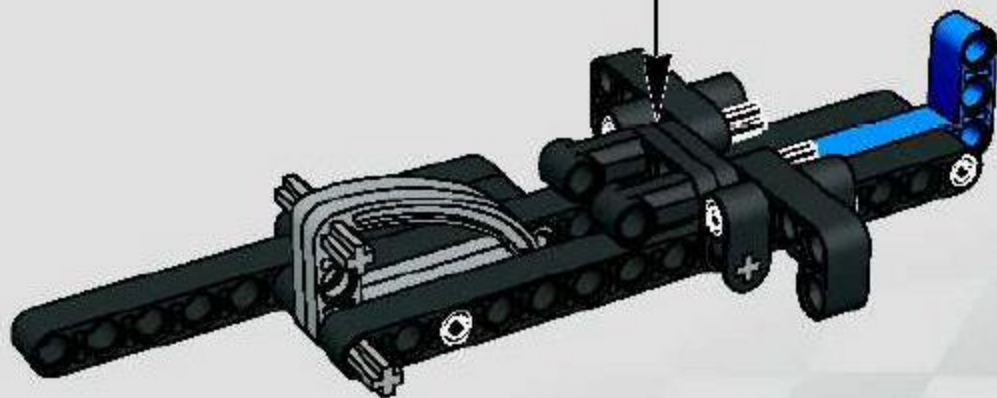
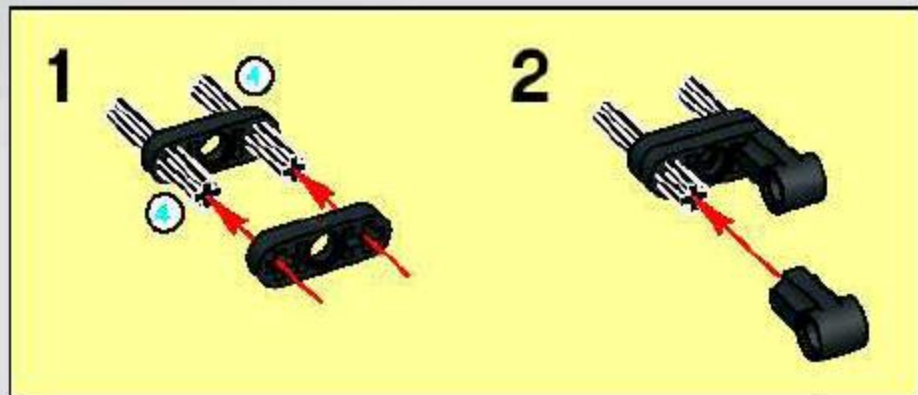



9

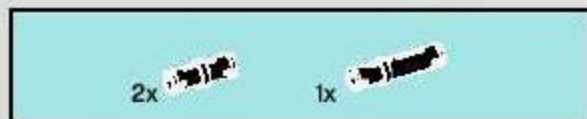
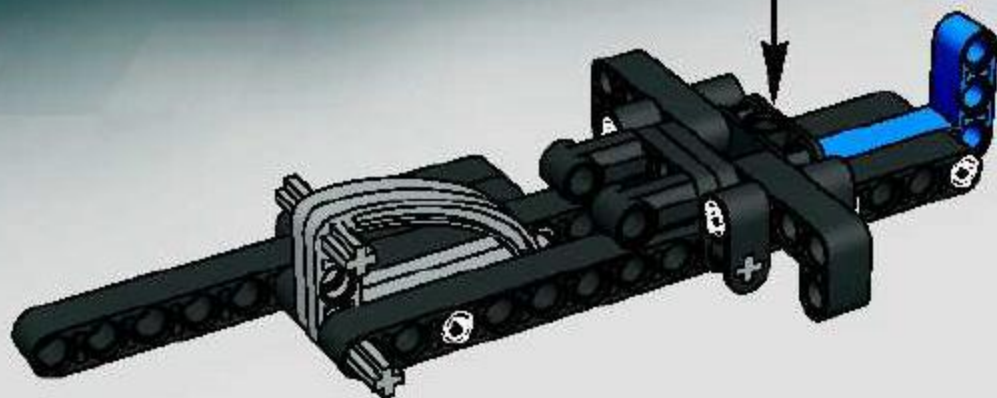

10

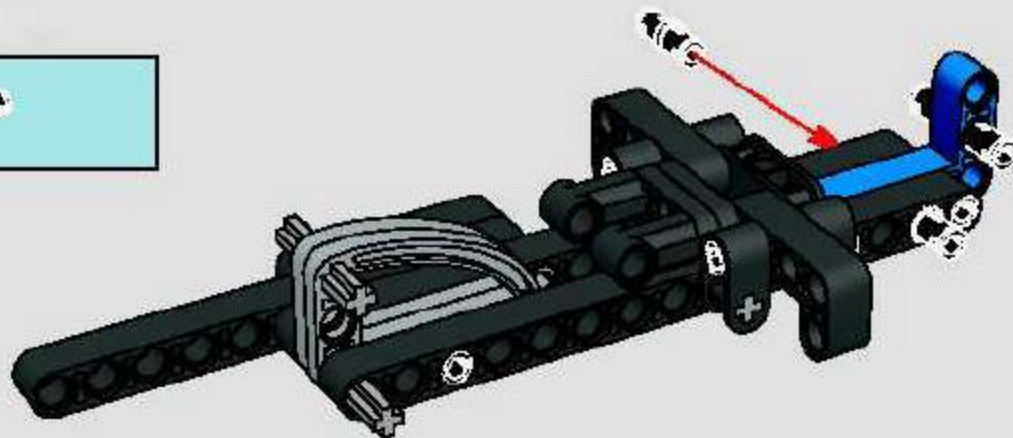

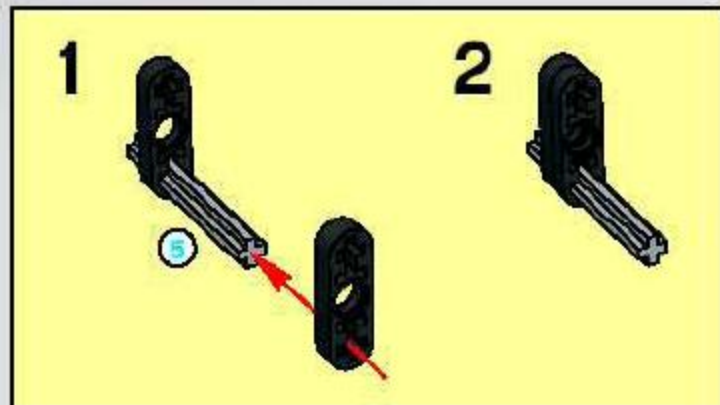
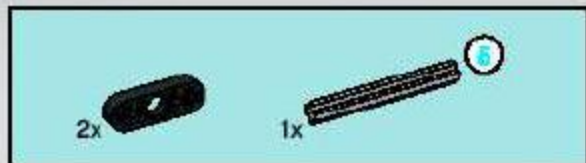

11

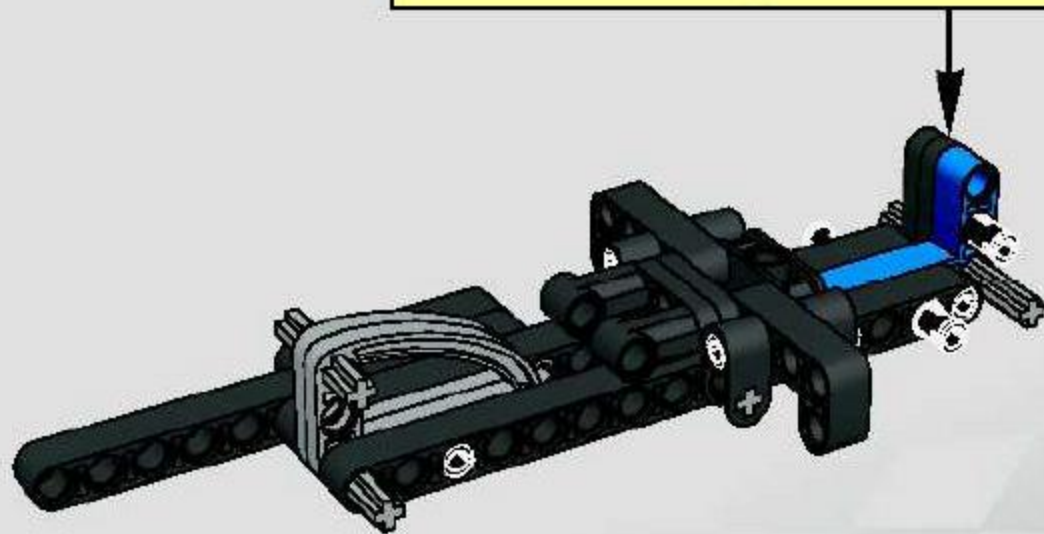



2x

12

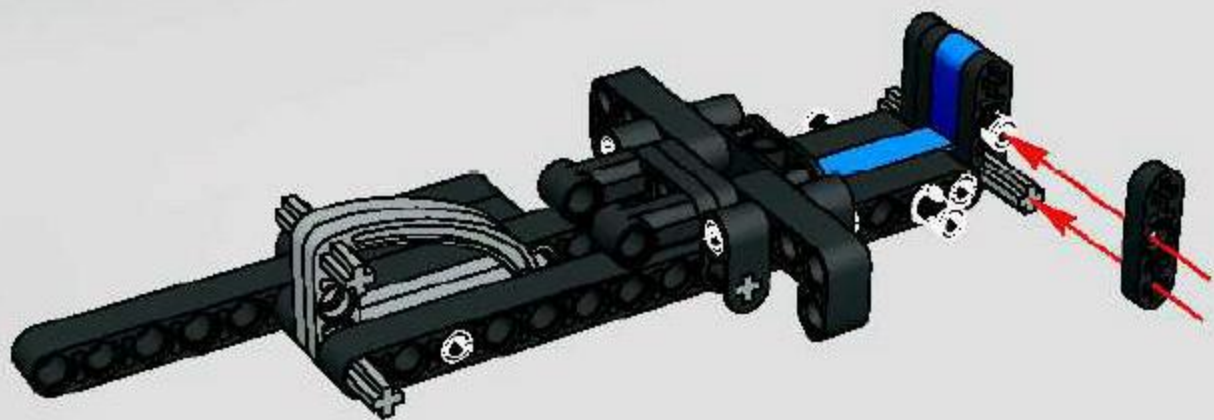

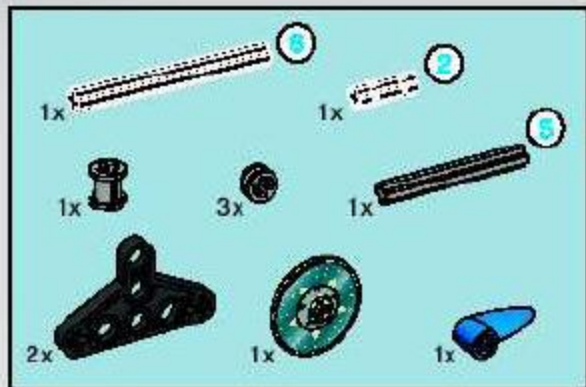

13

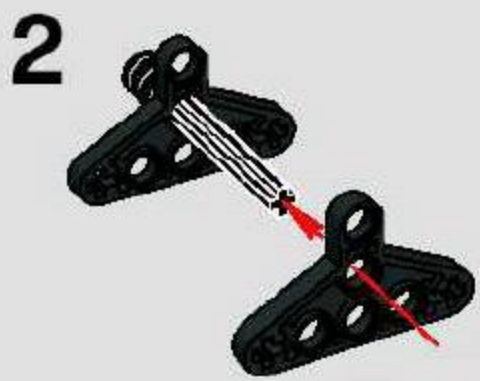
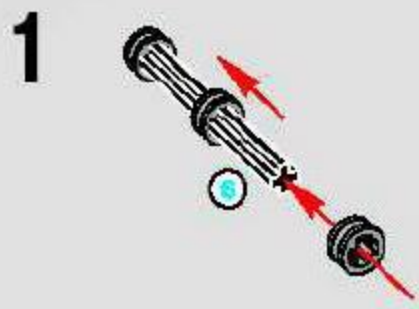
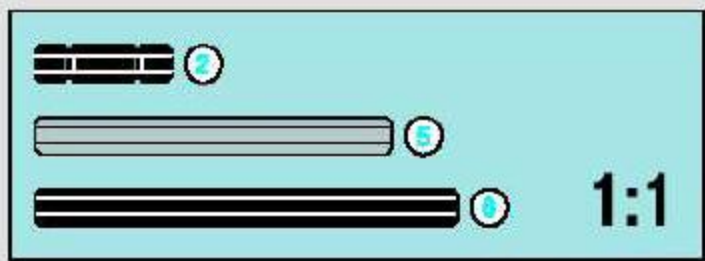

4



5

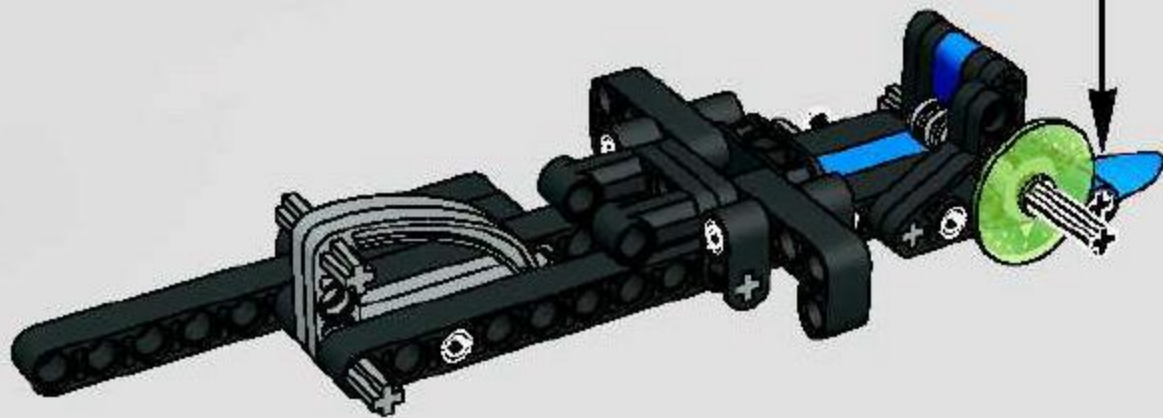

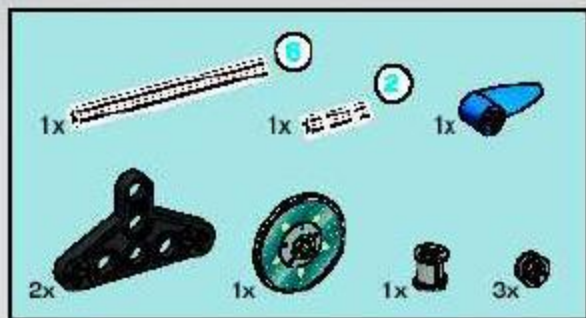

14

1

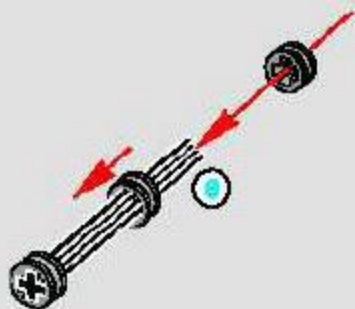

2

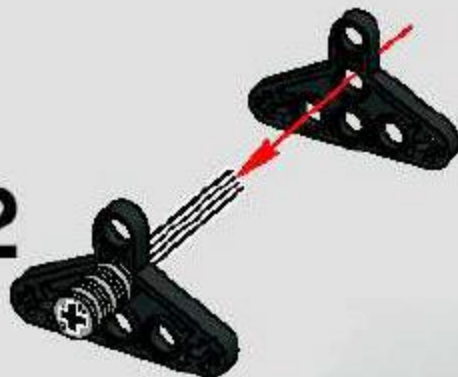

3

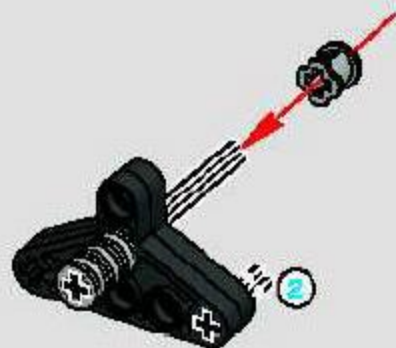

4



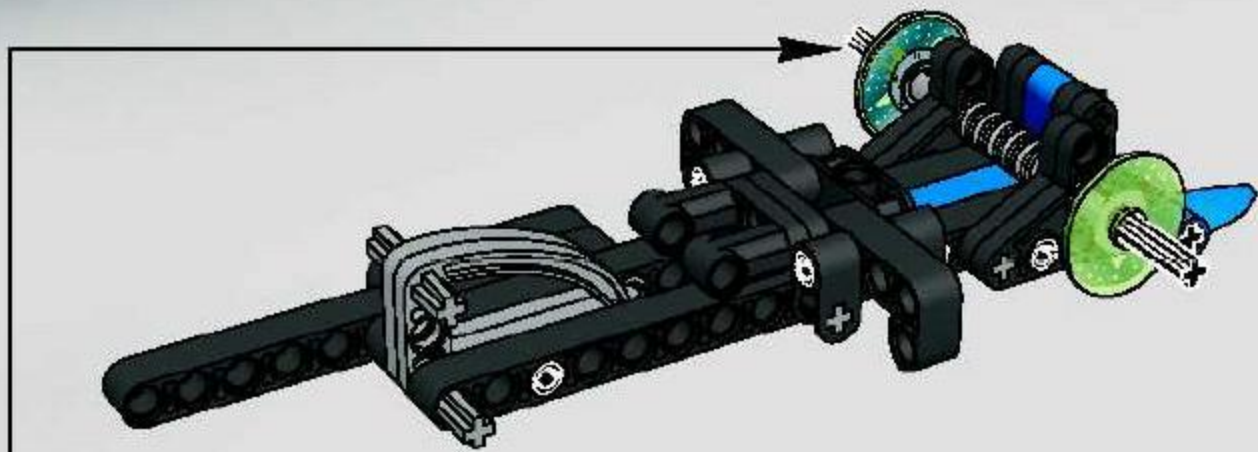



8645

8646

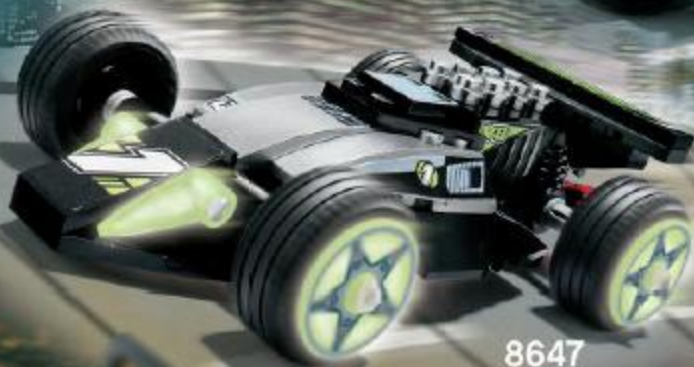

8647



8648



8650



www.LEGO.com/racers



8362



8375



8386



8389



RACERS



8652



www.LEGO.com/racers

Win! Gagne! Gewinne! 当たります



WIN LEGO® PRODUCTS

We would like to know what you think about our new LEGO® product. If you could help us by answering a few questions you are in with a chance of winning an exciting LEGO prize. It will only take you about 3 minutes! Log on to the web address below for further instructions.

We would really like to hear what you think about your new LEGO product. If you'd like to help us, go to the web address below for further instructions.



Estimado usuario LEGO®

Al contestar algunas preguntas en inglés, francés, alemán o japonés, en el sitio www.acnielsen.aim.dk/lego, podrás participar en el sorteo de algunos valiosos premios LEGO®.



お客様でLEGO®製品が当たります

私たちは、皆さんが買い入れたLEGO®製品についてどんな感想をお持ちか、知りたいと思っています。質問に答えて、楽しいLEGO®製品の抽選に応募していただくと、アンケートの回答には、LEGO®の素晴らしいプレゼントが当たる可能性があります。お申し込みは、以下のウェブアドレスからお願いします。



GAGNE DES PRODUITS LEGO®

Nous aimerions savoir ce que tu penses de ton nouveau produit LEGO®. Si tu veux bien nous aider en répondant à quelques questions, tu recevras peut-être bientôt un fantastique prix LEGO. Et cela ne te prendra que 3 minutes environ ! Tu obtiendras davantage d'informations en visitant le site Internet indiqué ci-dessous.

Nous aimerions savoir ce que tu penses de ton nouveau produit LEGO. Si tu souhaites nous aider, rends-toi à l'adresse Internet ci-dessous où tu trouveras des instructions supplémentaires.



Caro Consumidor de LEGO®

Ao responder a algumas perguntas em Inglês, Francês, Alemão ou Japonês no endereço www.acnielsen.aim.dk/lego irá participar num concurso para ganhar valiosos prémios de LEGO®.



GEWINNE LEGO® PRODUKTE

Wir sind sehr an deiner Meinung über dein neues LEGO® Produkt interessiert. Wenn du uns den Gefallen tust und ein paar Fragen beantwortest, kannst du einen tollen LEGO Prelo gewinnen. Das Ganze dauert nur etwa 3 Minuten! Gehe einfach zu der unten angegebenen Webadresse - dort findest du weitere Informationen.

Wir möchten gerne wissen, was Sie von Ihrem neuen LEGO Produkt halten. Wenn Sie uns helfen möchten, besuchen Sie bitte die u.a. Website, auf der Sie alles Weitere erfahren.



Kedves LEGO® Vásárló

Ha ellátogat az www.acnielsen.aim.dk/lego honlapra és ott angol, francia, német vagy japán nyelven megválaszolsz néhány kérdést, akkor részt veszel egy versenyben, amelyben értékes LEGO® díjakat nyerhetsz.

www.acnielsen.aim.dk/LEGO



LEGO® the LEGO logo, the CLIPIT® logo and BIONICLE are a registered trademark of the LEGO Group.
©2006 The LEGO Group.
Fennél: all sponsored logos and the distinctive designs are trademarks of Ferrari S.p.A.
The body of the Ferrari car is protected as Ferrari copyright under Italian design model design regulations.



www.LEGO.com/racers

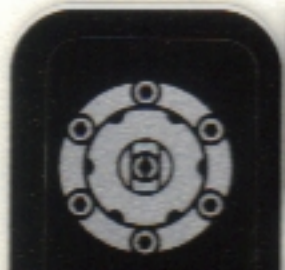
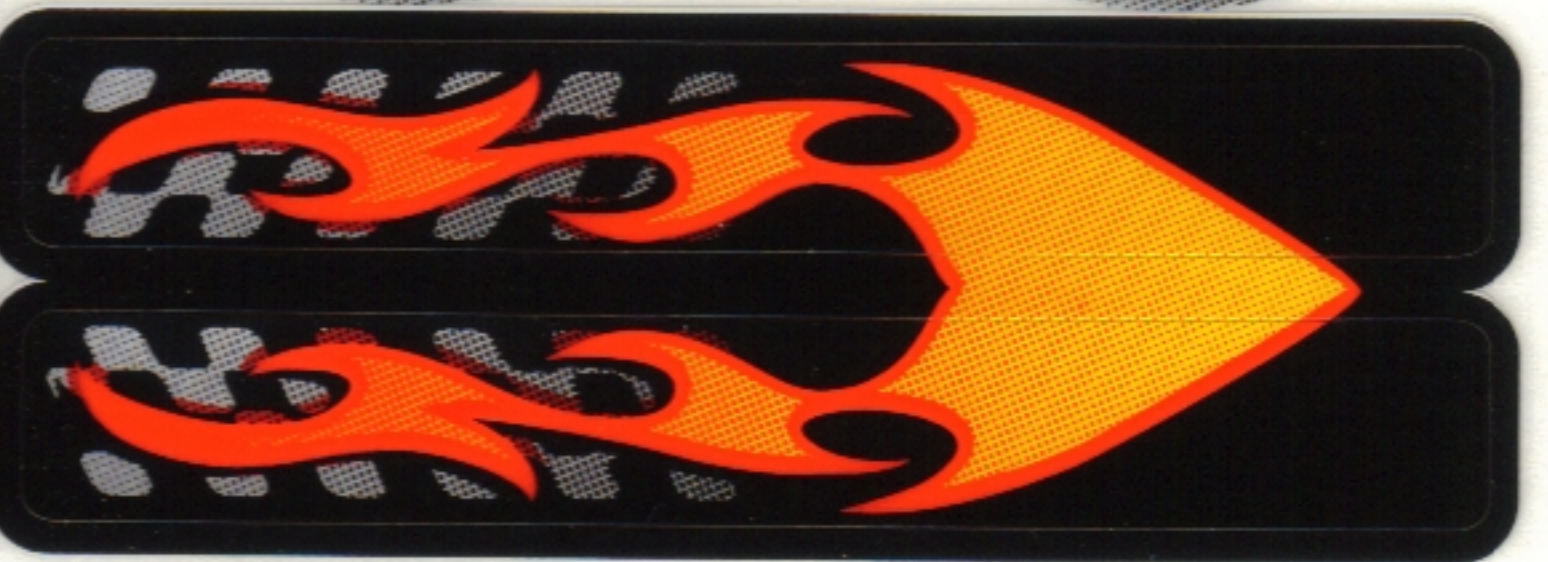
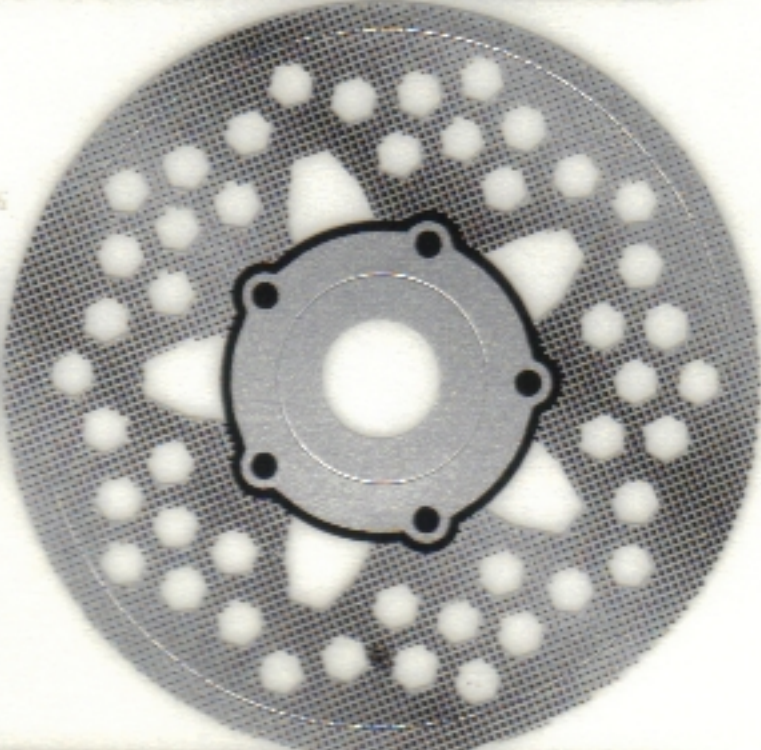
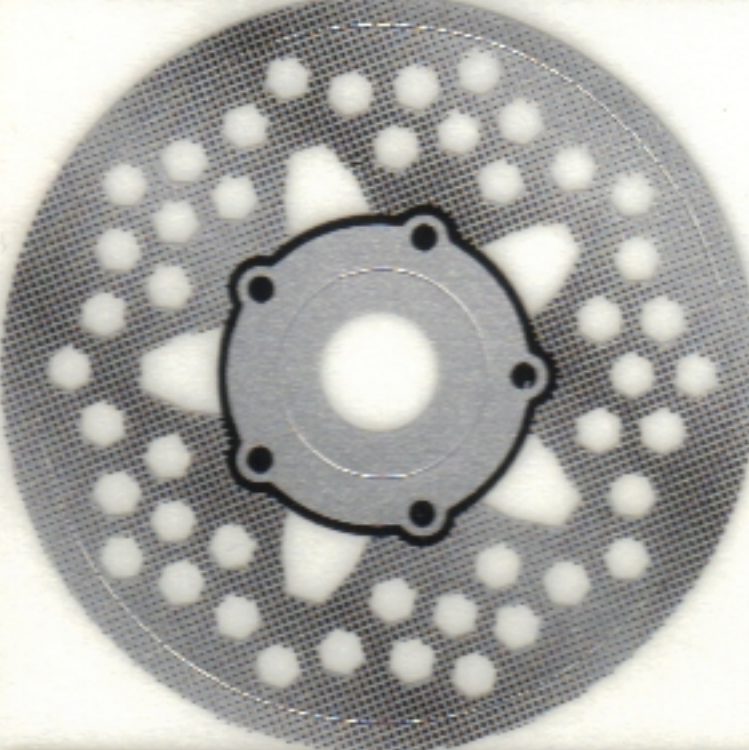
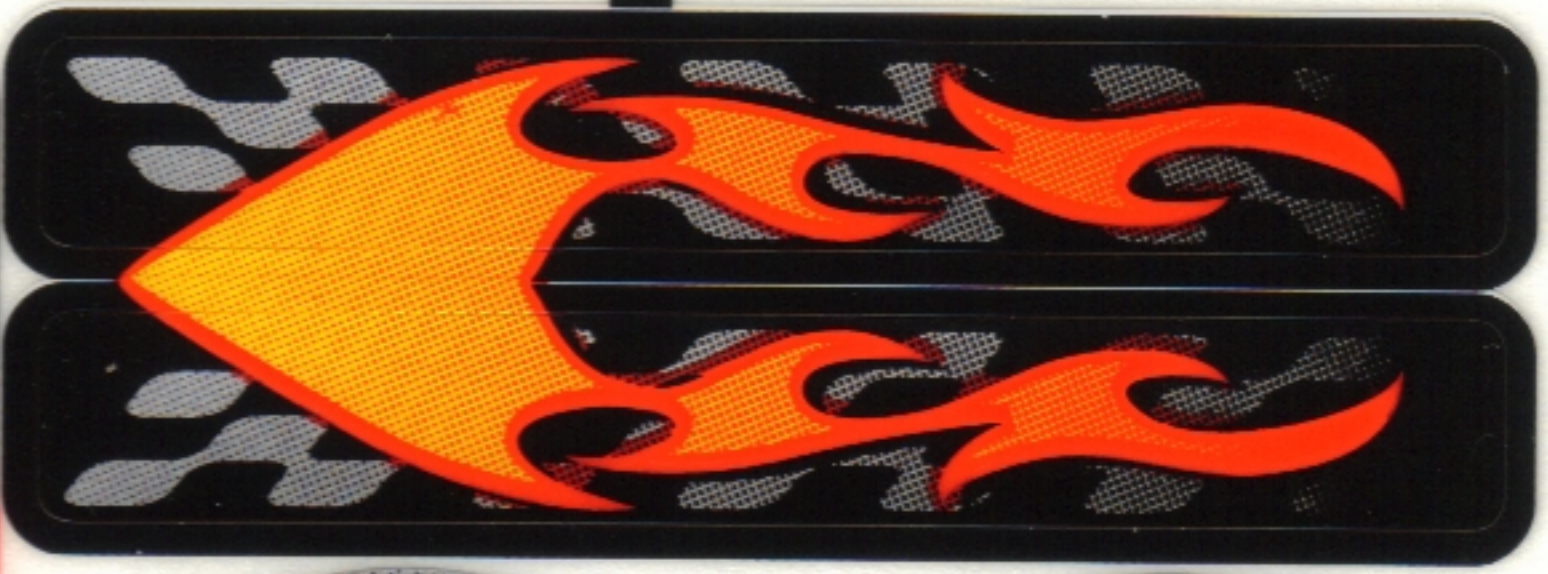

52167/4254496 © 2005 LEGO GROUP

12 13 14 15 16 17 18 19