

3367

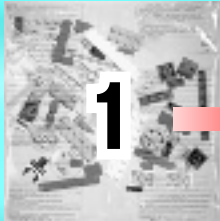

**WARNING: CHOKING HAZARD.**  
Toy contains small parts and a small ball.  
Not for children under 3 years.



1

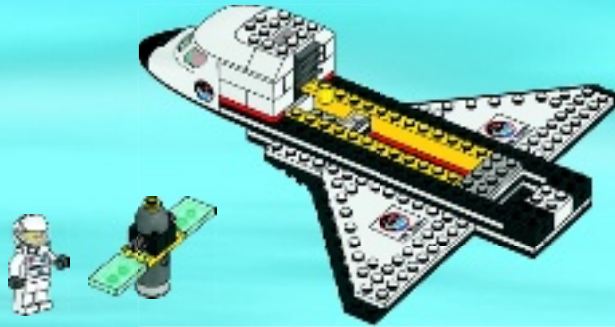

2

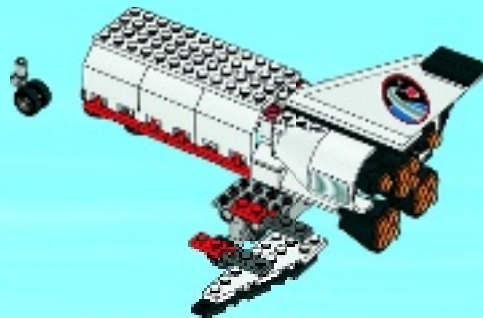

**AVERTISSEMENT : RISQUE D'ÉTOUFFEMENT.**  
Le jouet contient des petites pièces ainsi qu'une petite boule.  
Il ne convient pas aux enfants de moins de 3 ans.



**ADVERTENCIA: PELIGRO DE ASFIXIA.**  
Juguete que contiene partes pequeñas y una pelota pequeña.  
No recomendado para niños menores de 3 años.

1

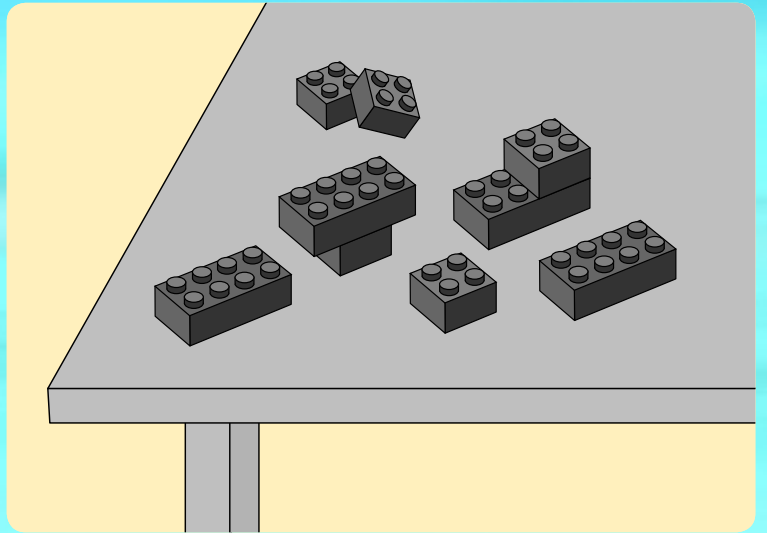
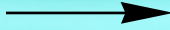
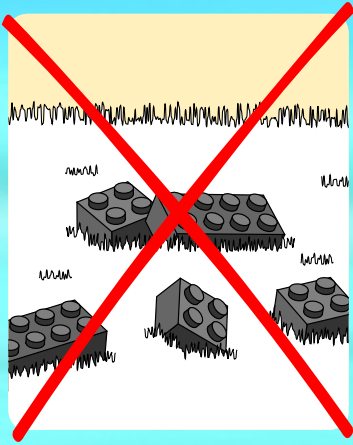

2

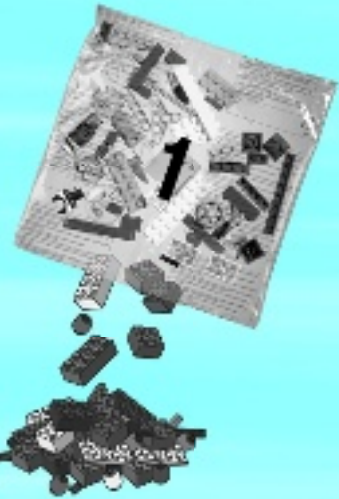
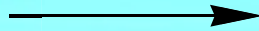

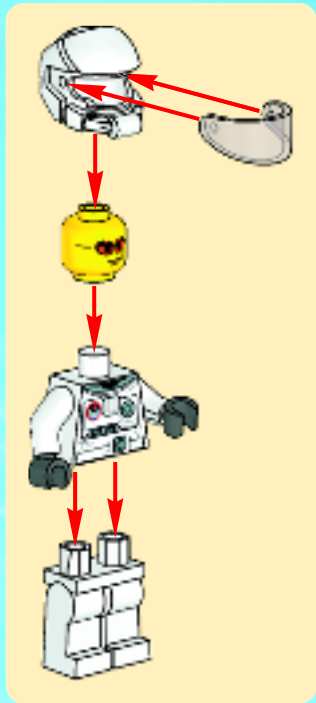
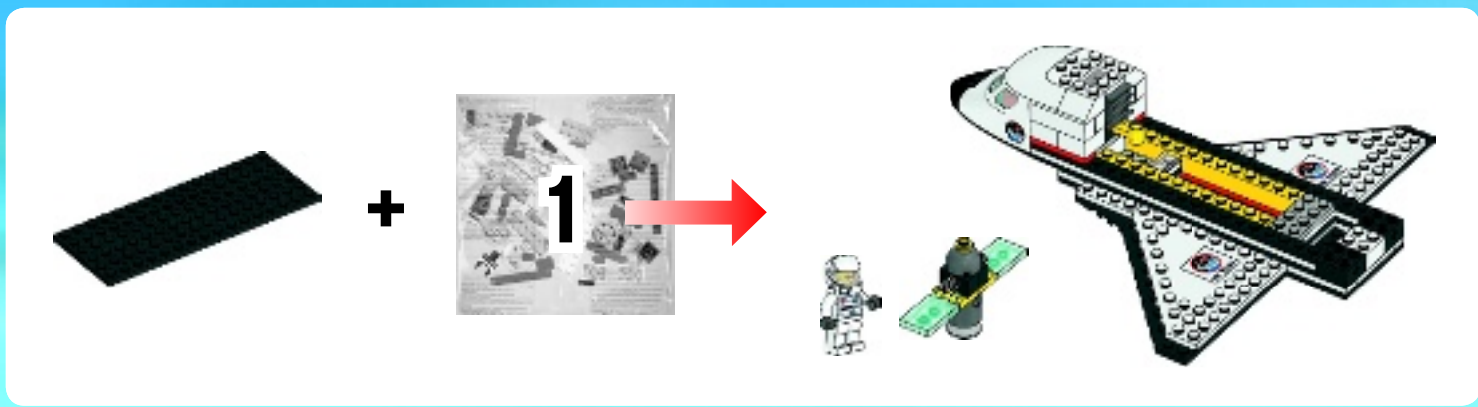

1



2





**3**

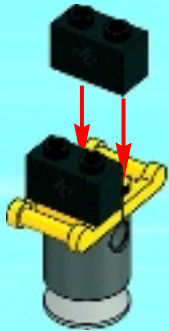

**4**



**5**



**6**



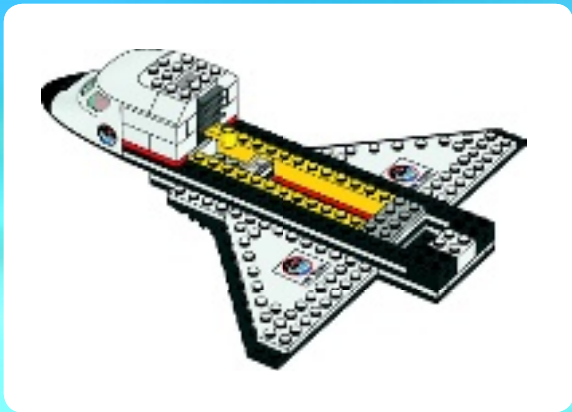

1



2



3

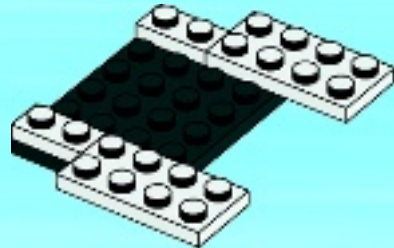

4

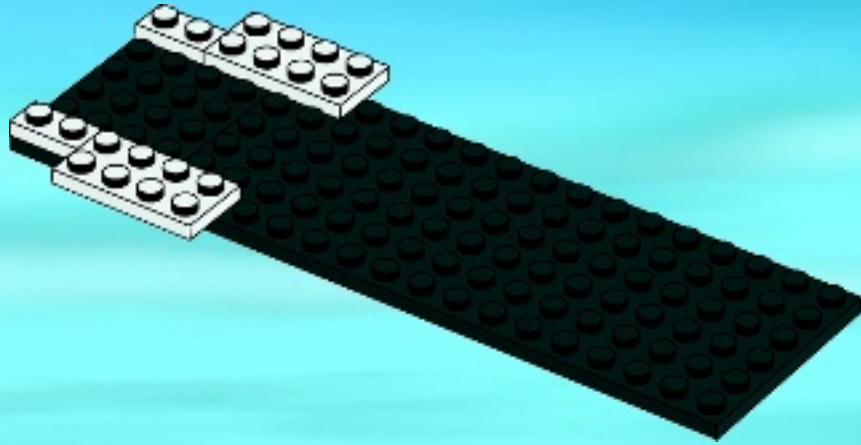

5

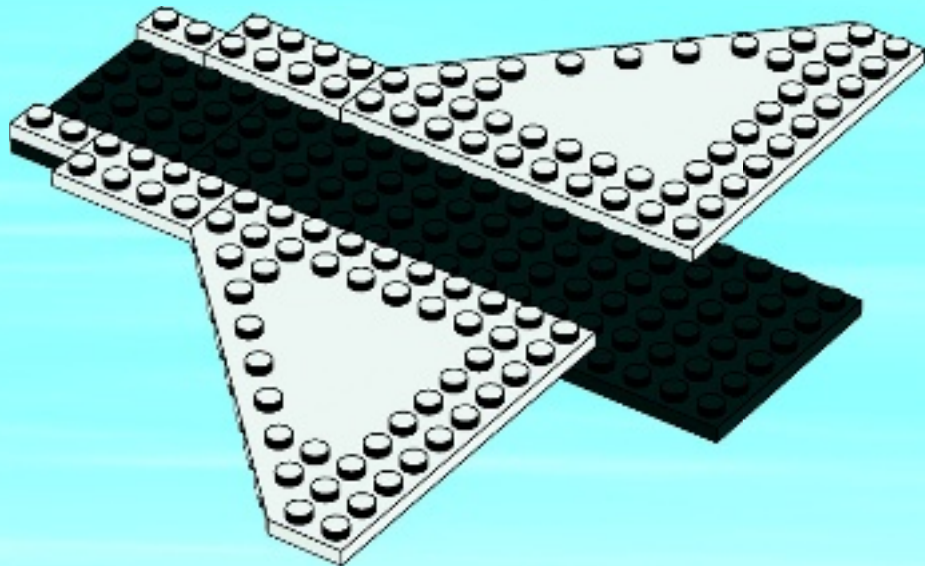

6

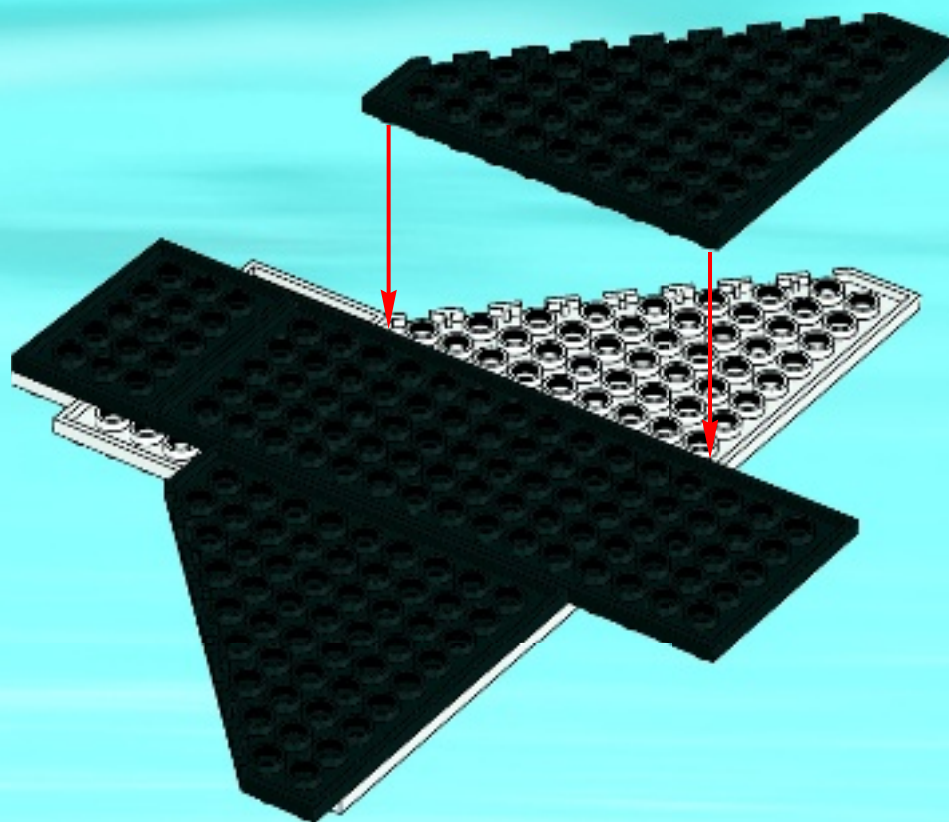



7

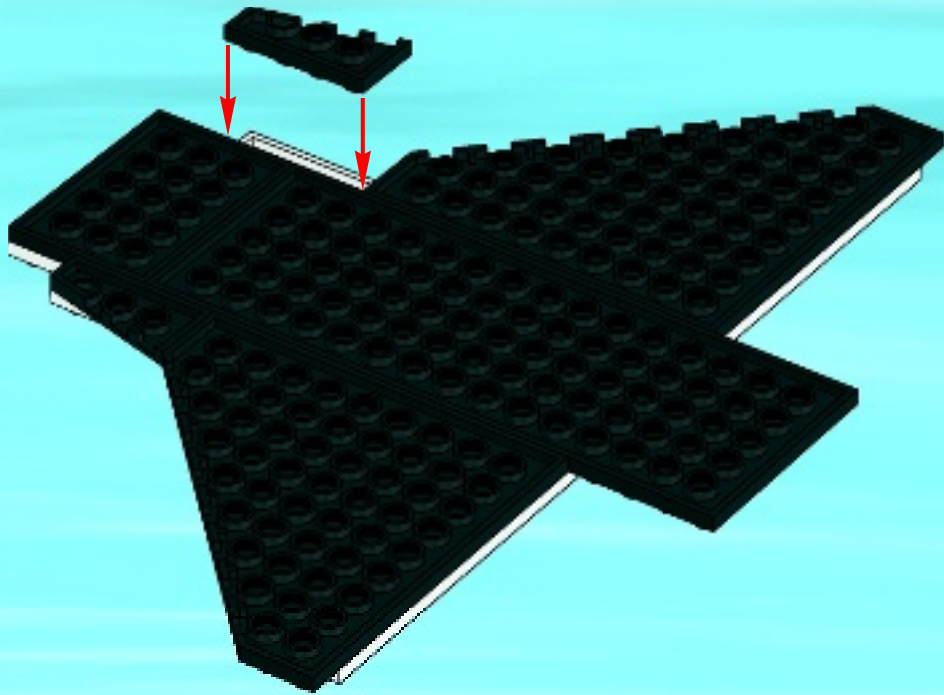



1

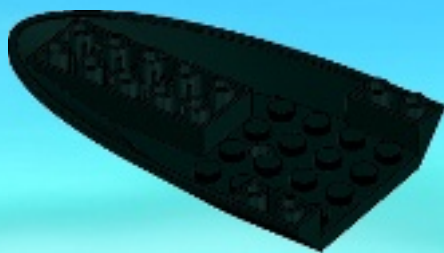

2

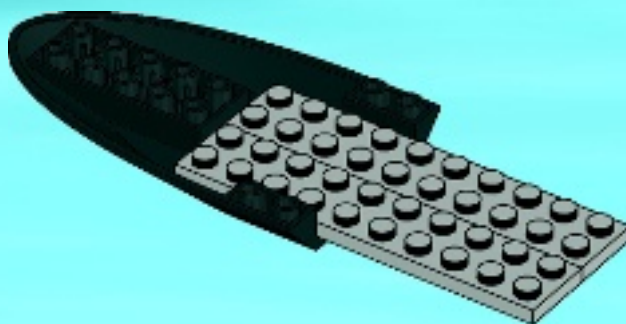

3

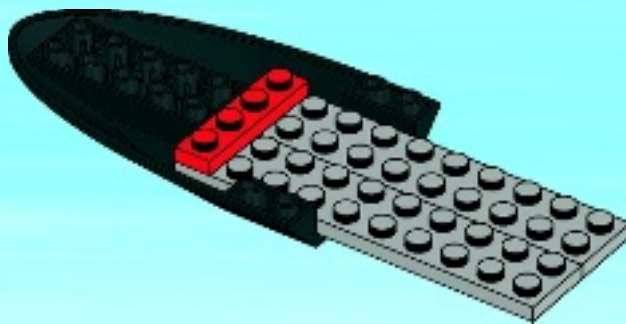

4

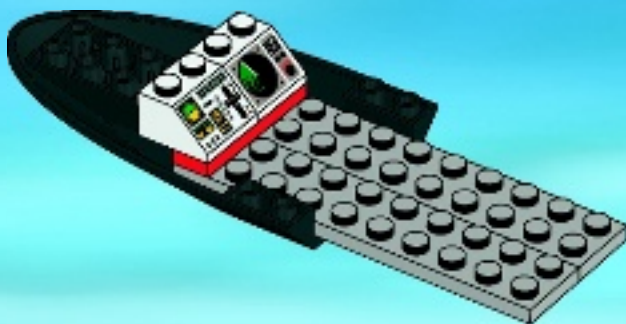

5

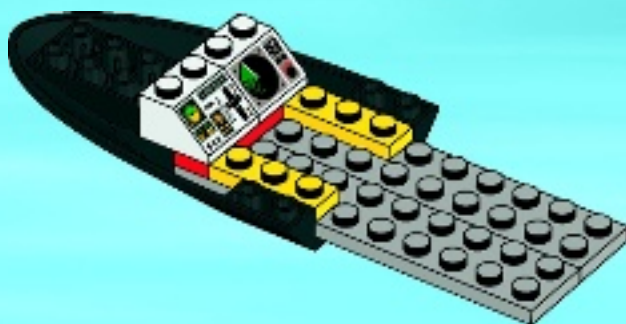

6

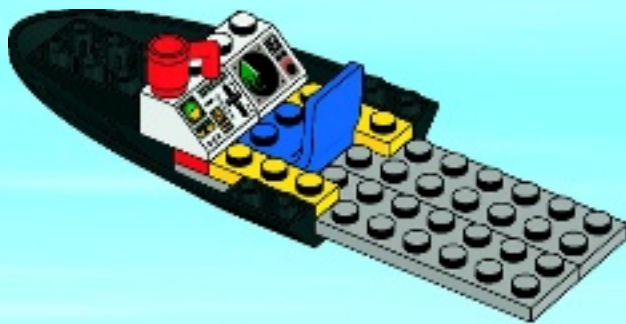

8

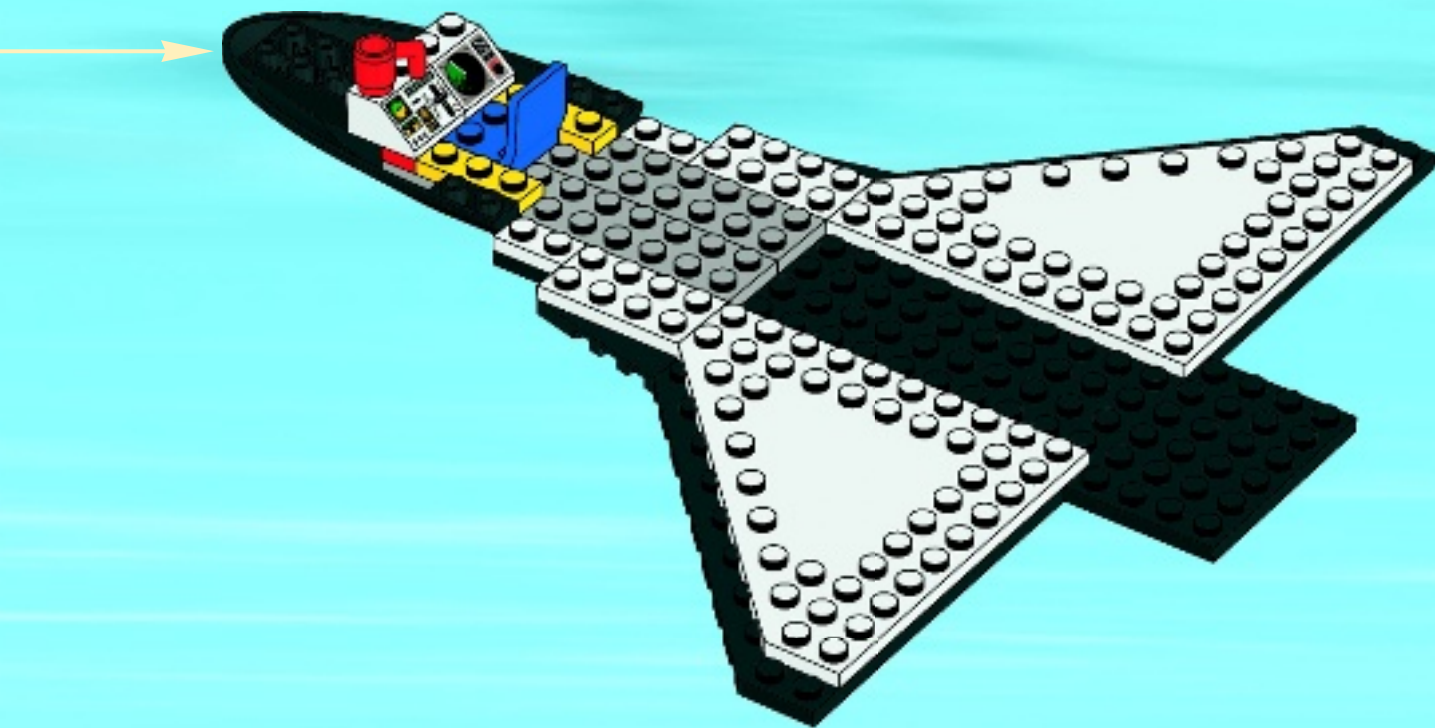



9

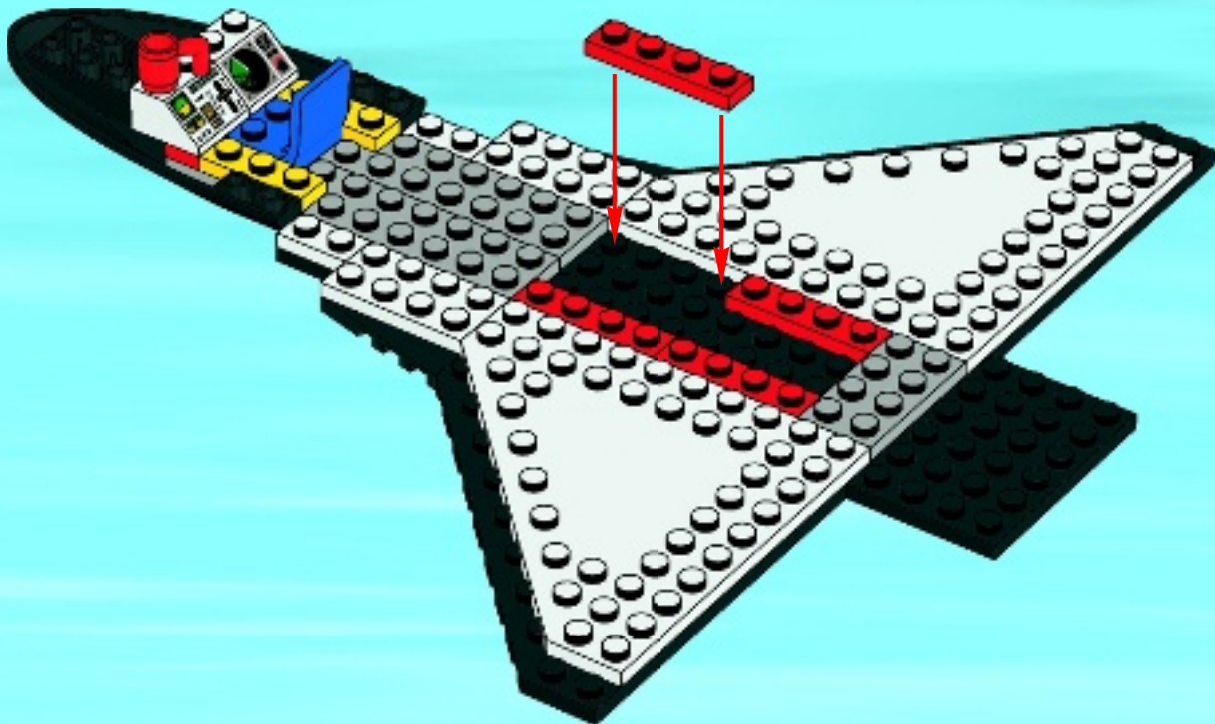

10

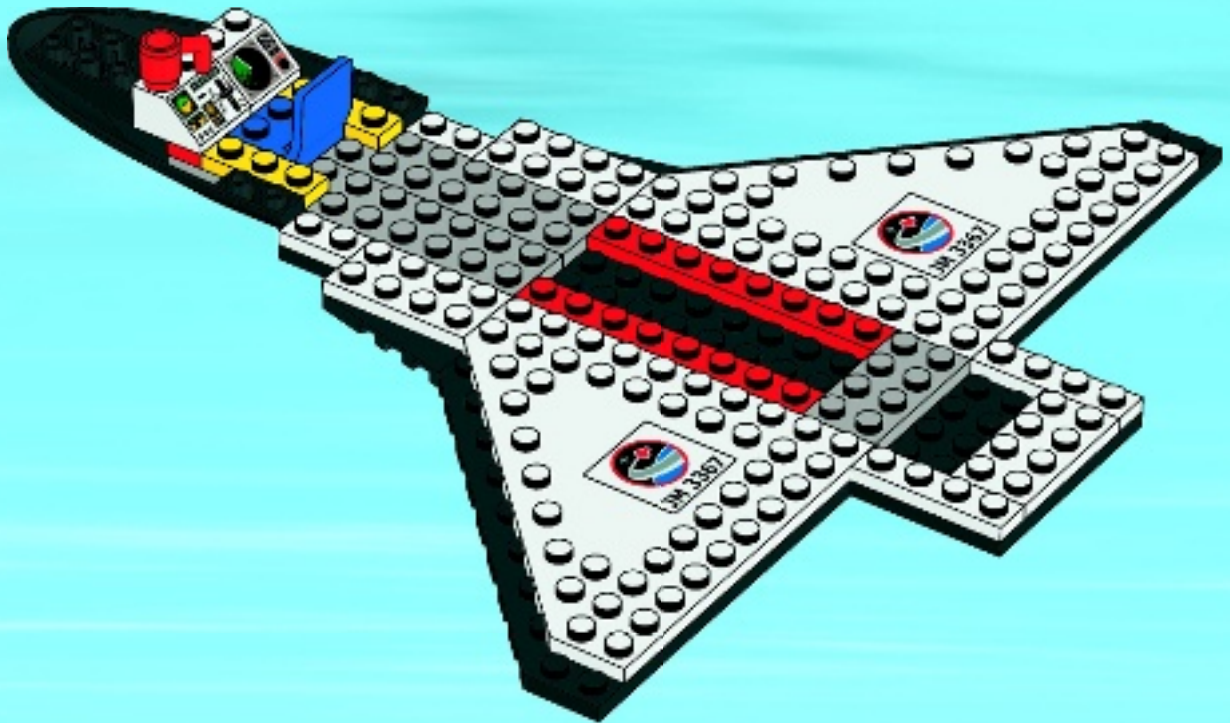

11

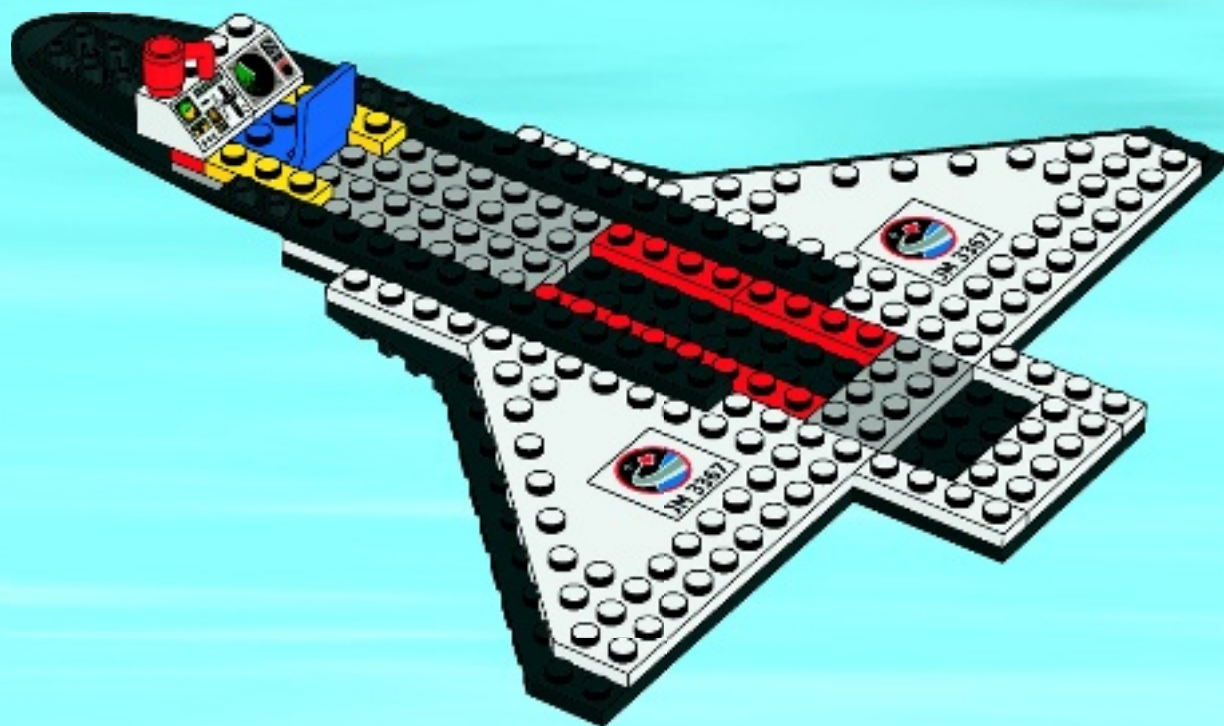

12

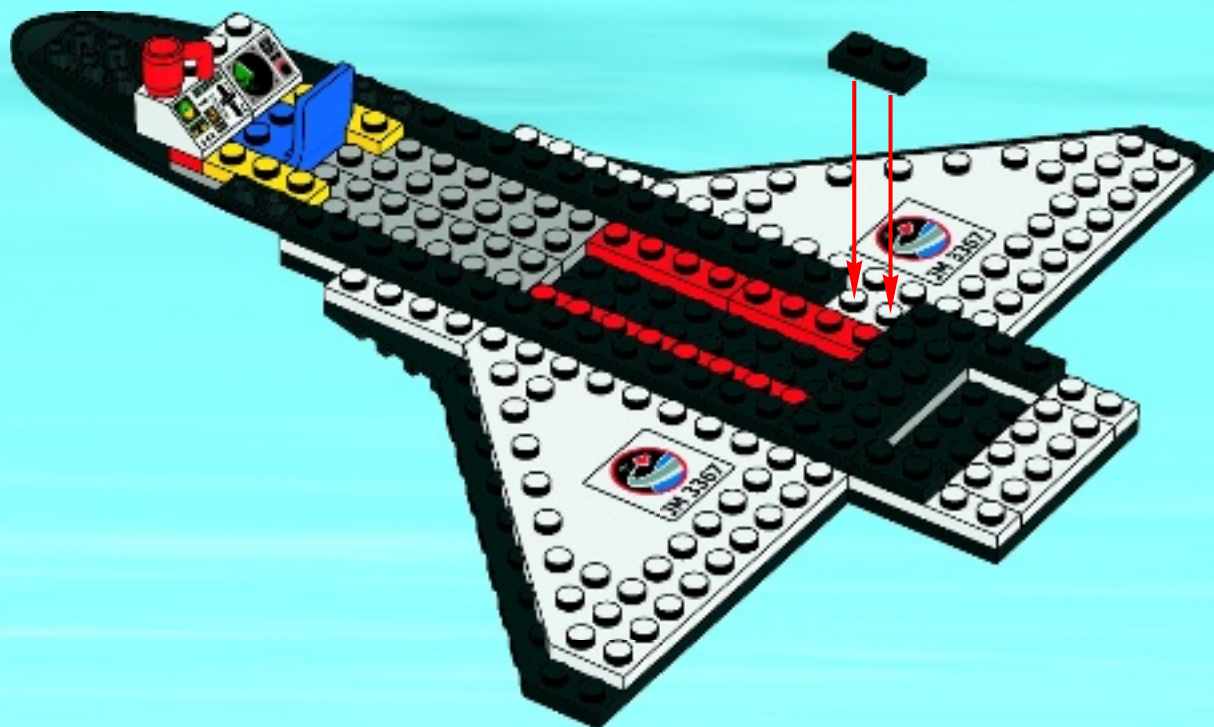



13

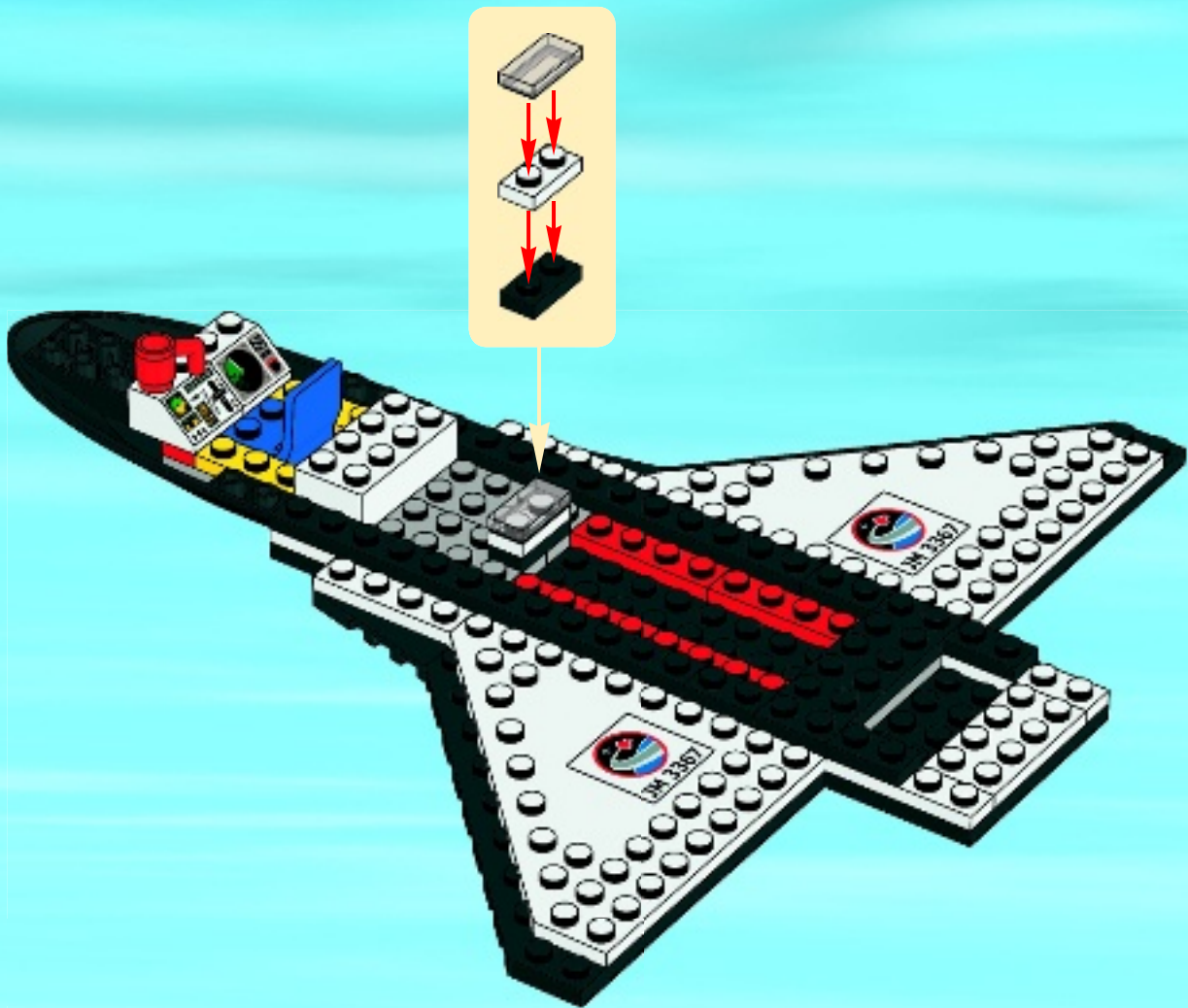

14

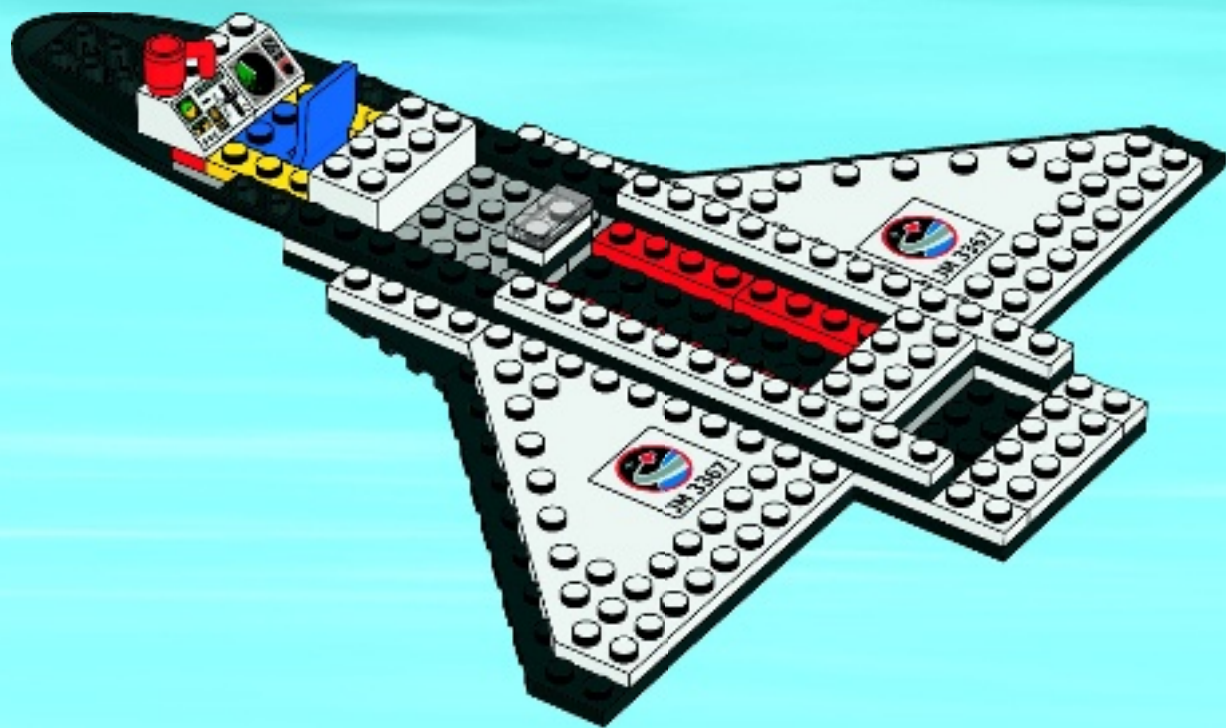

15

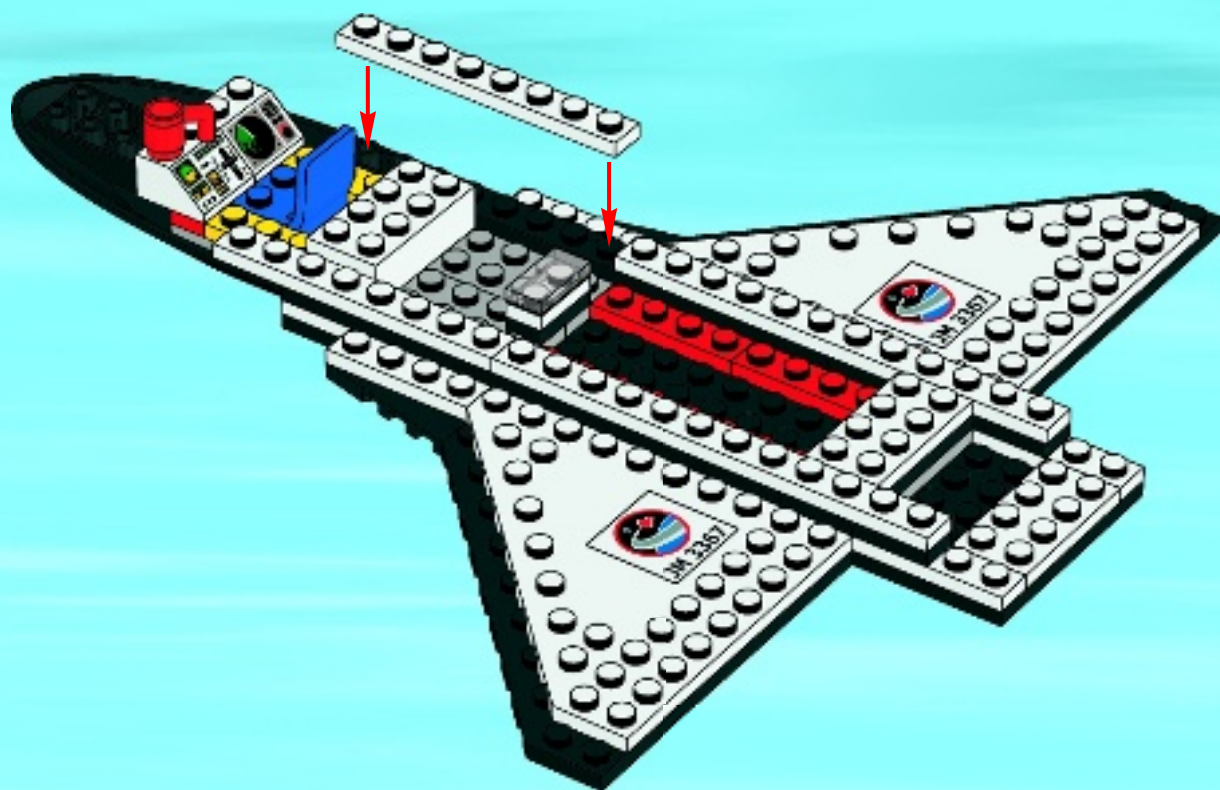

16

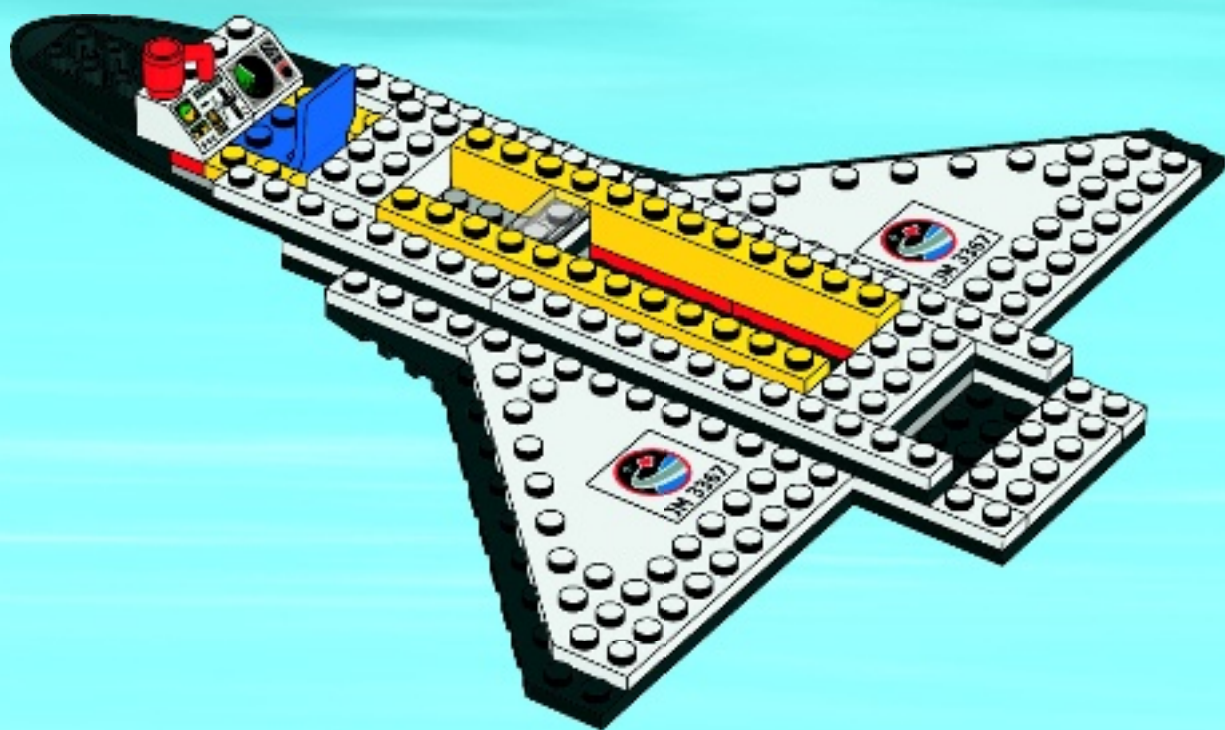



17

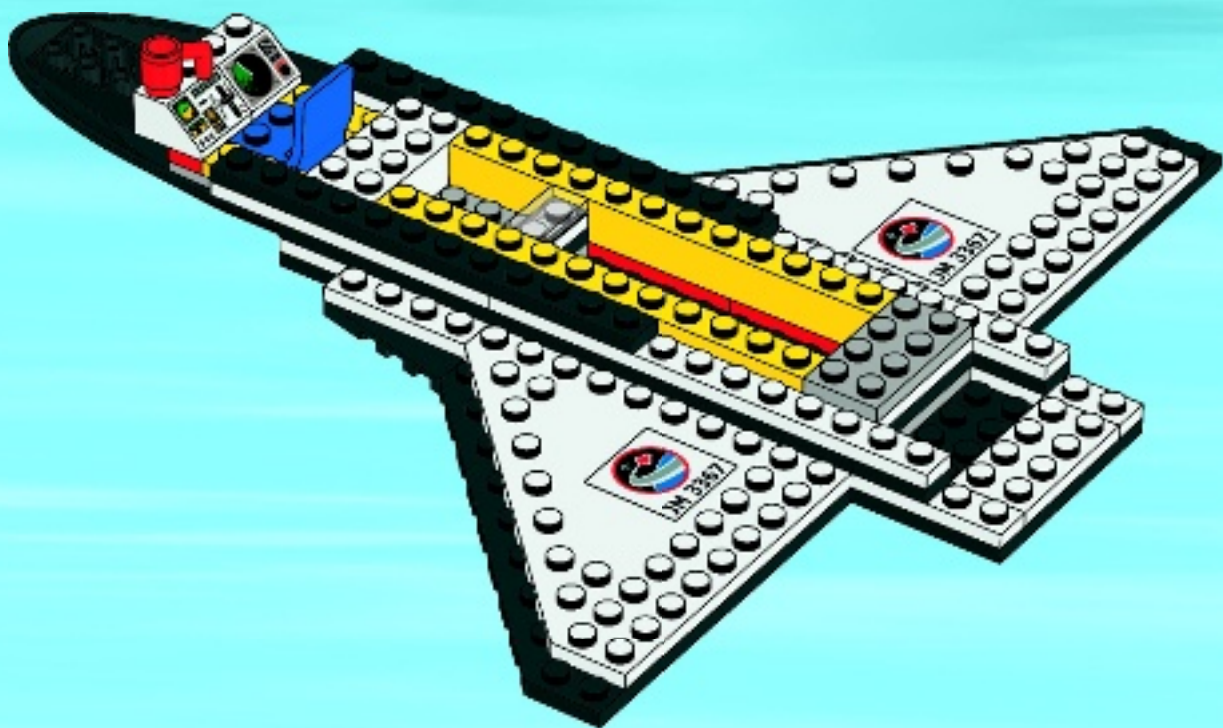

18

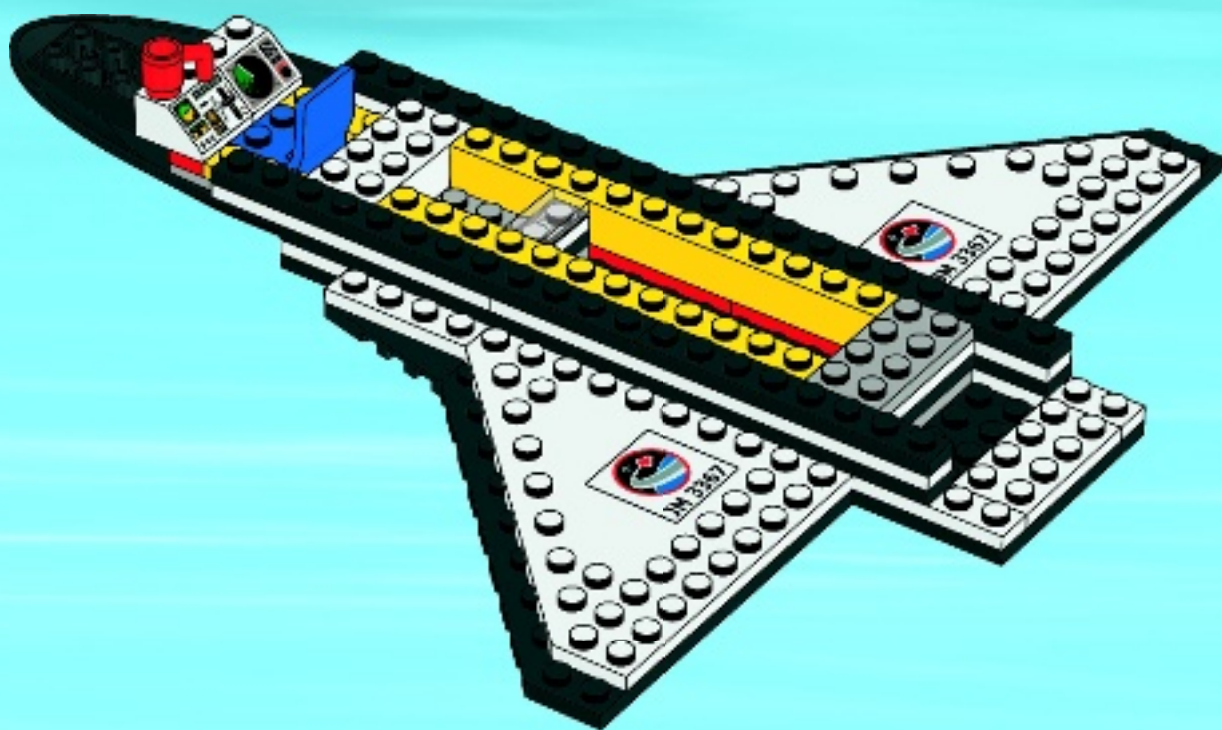

19

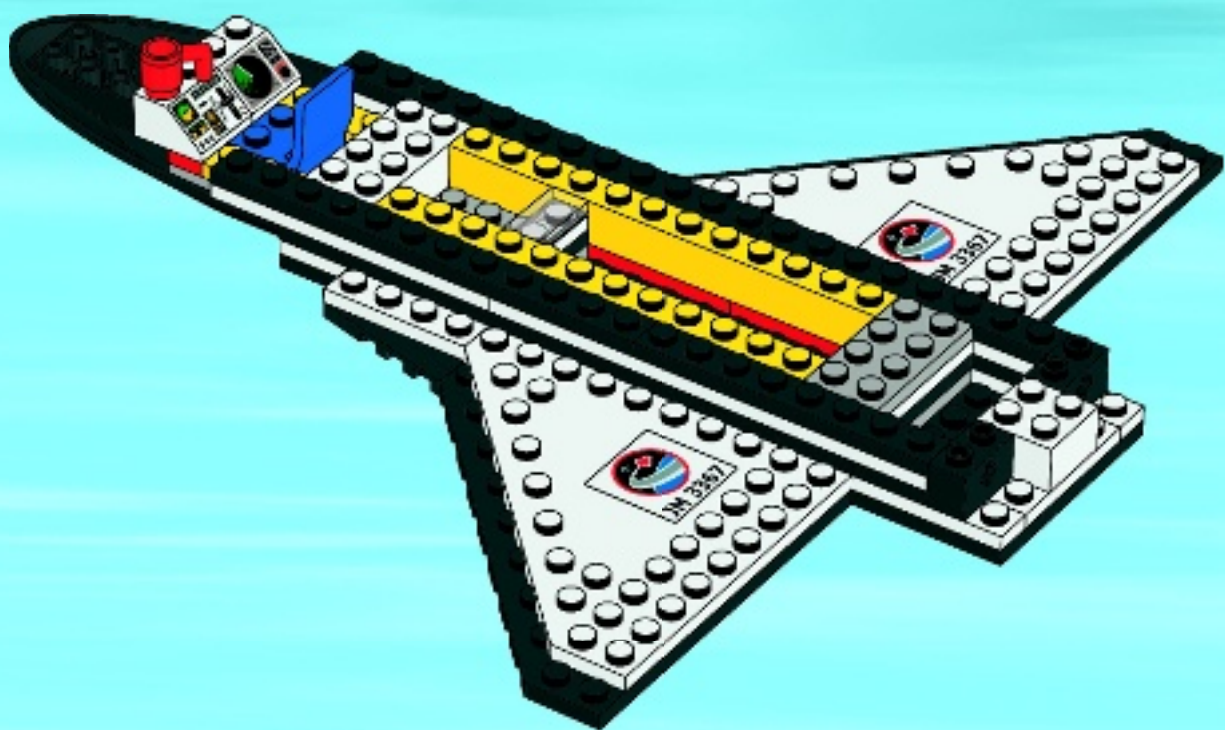

20

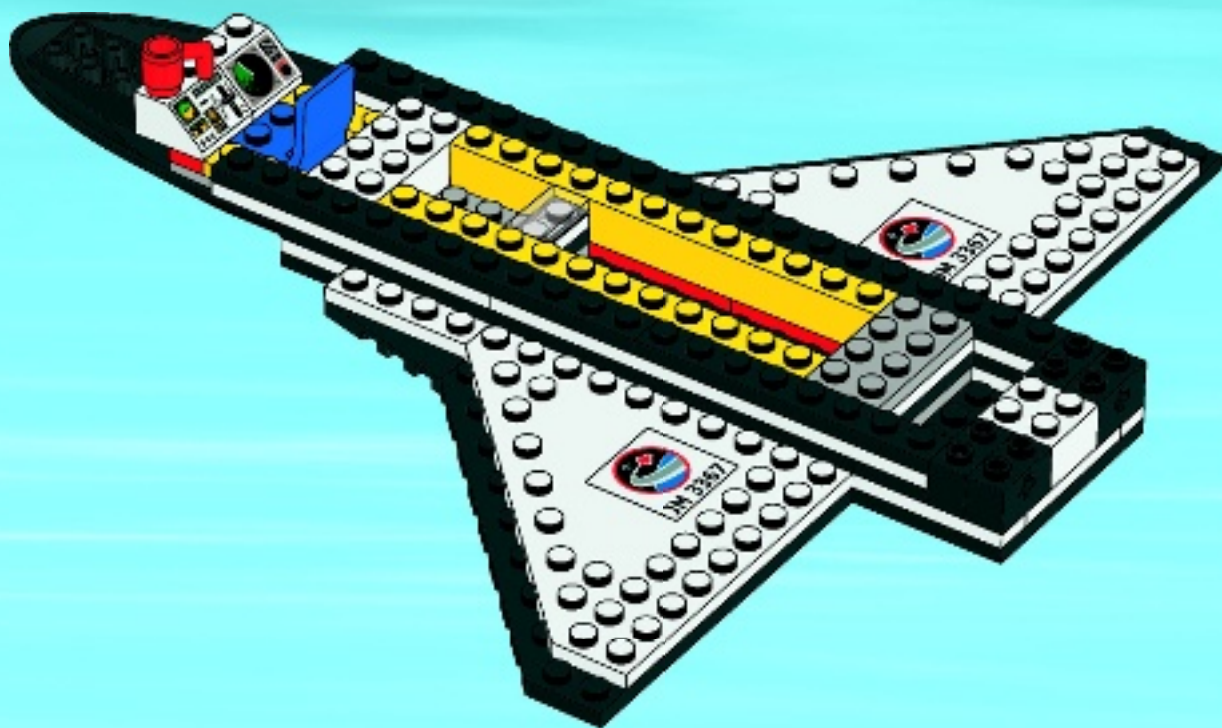



21

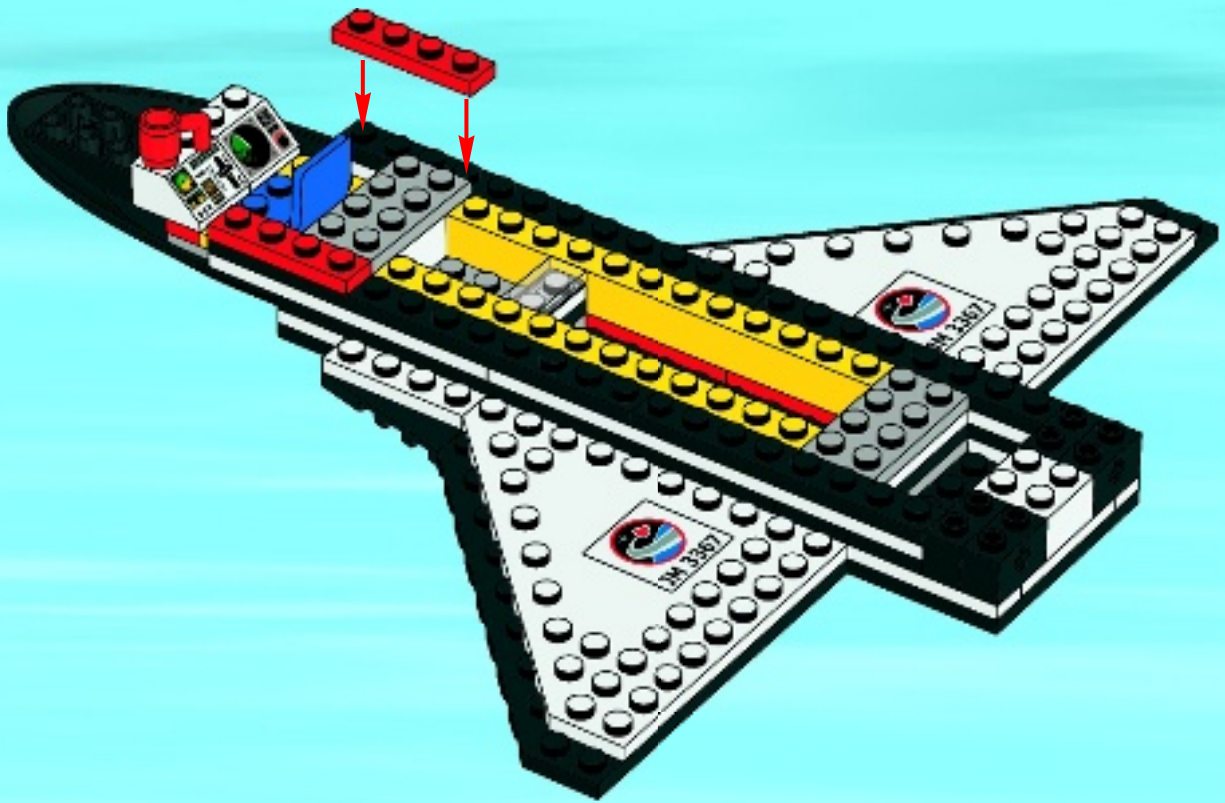

22

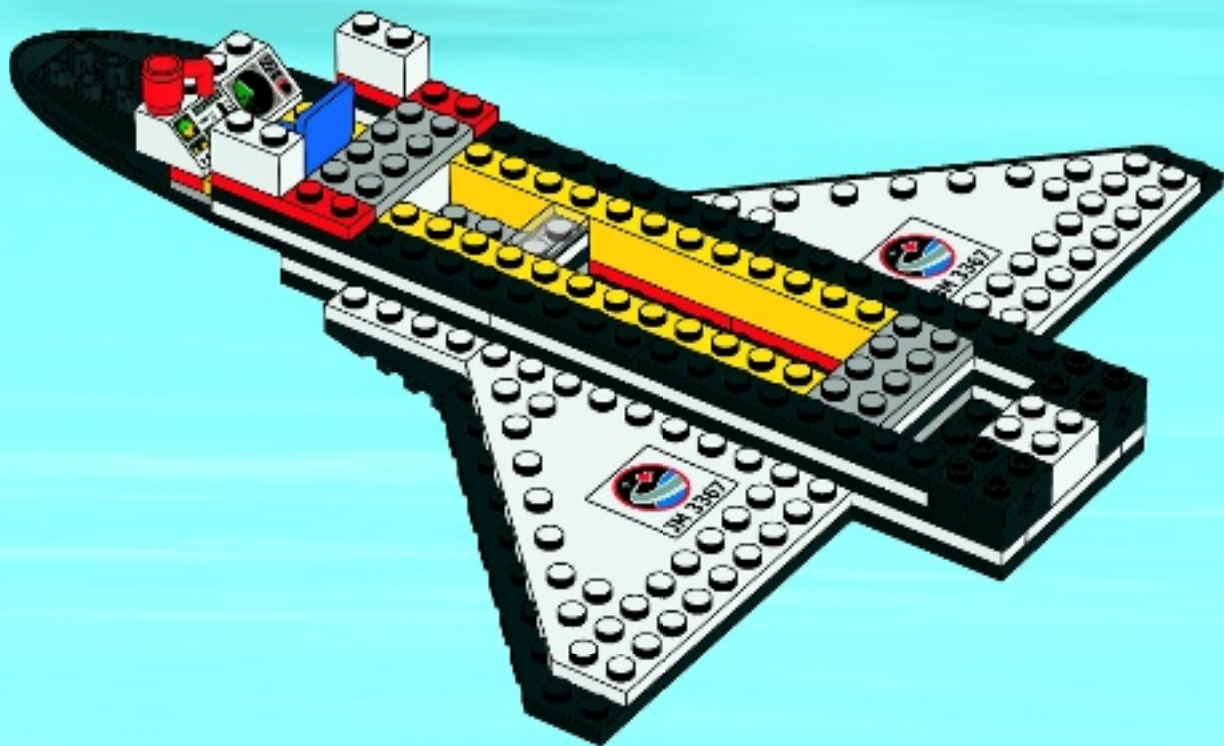

23

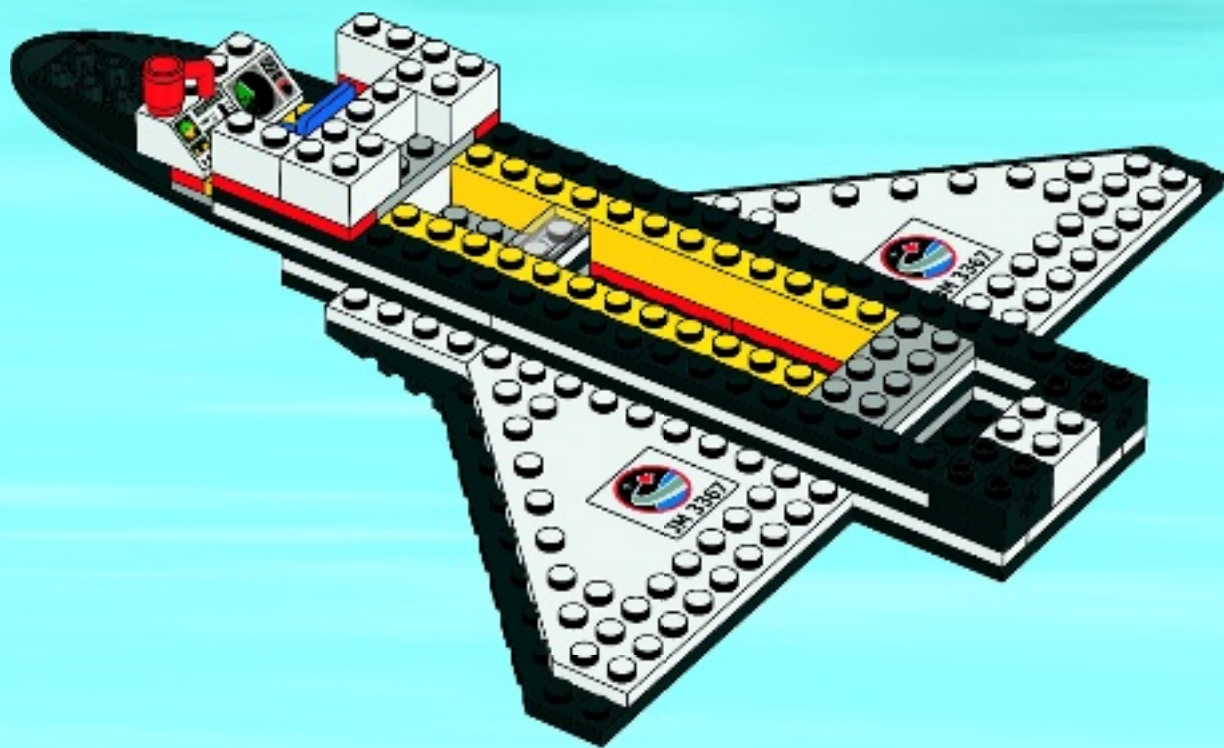

1

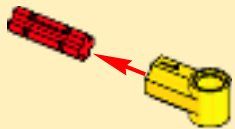

2

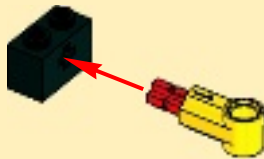

3



24

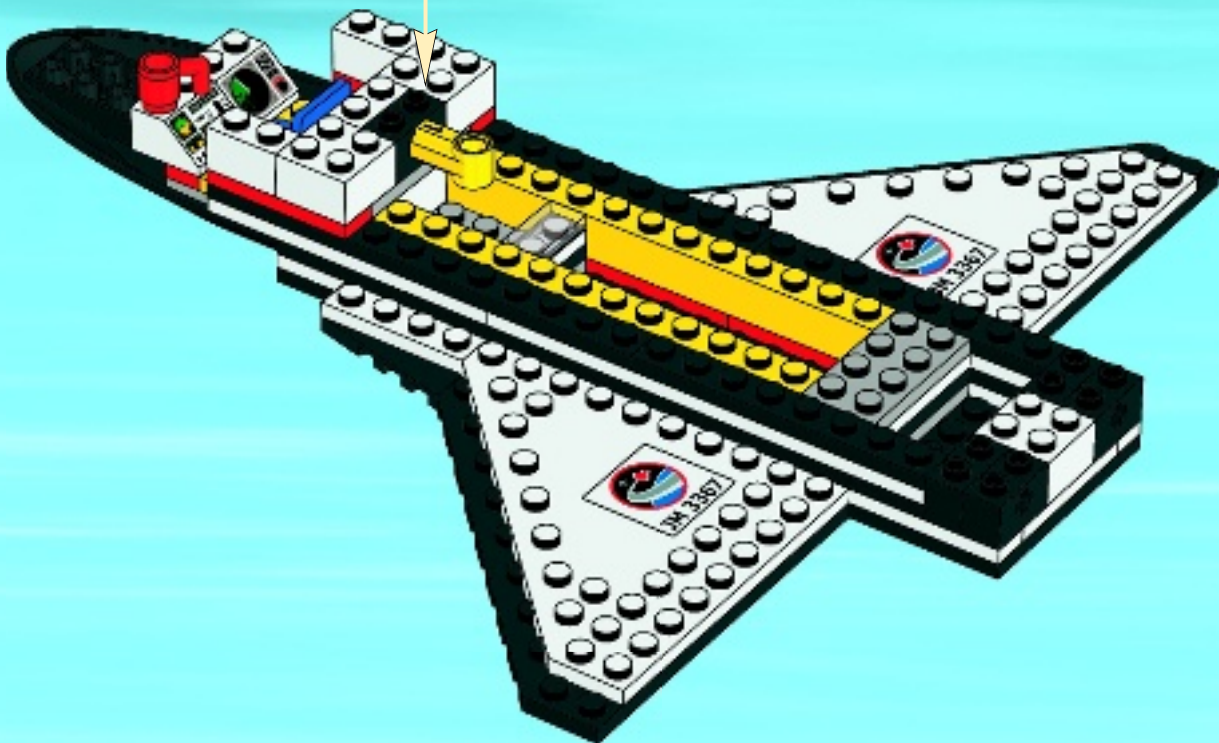



25

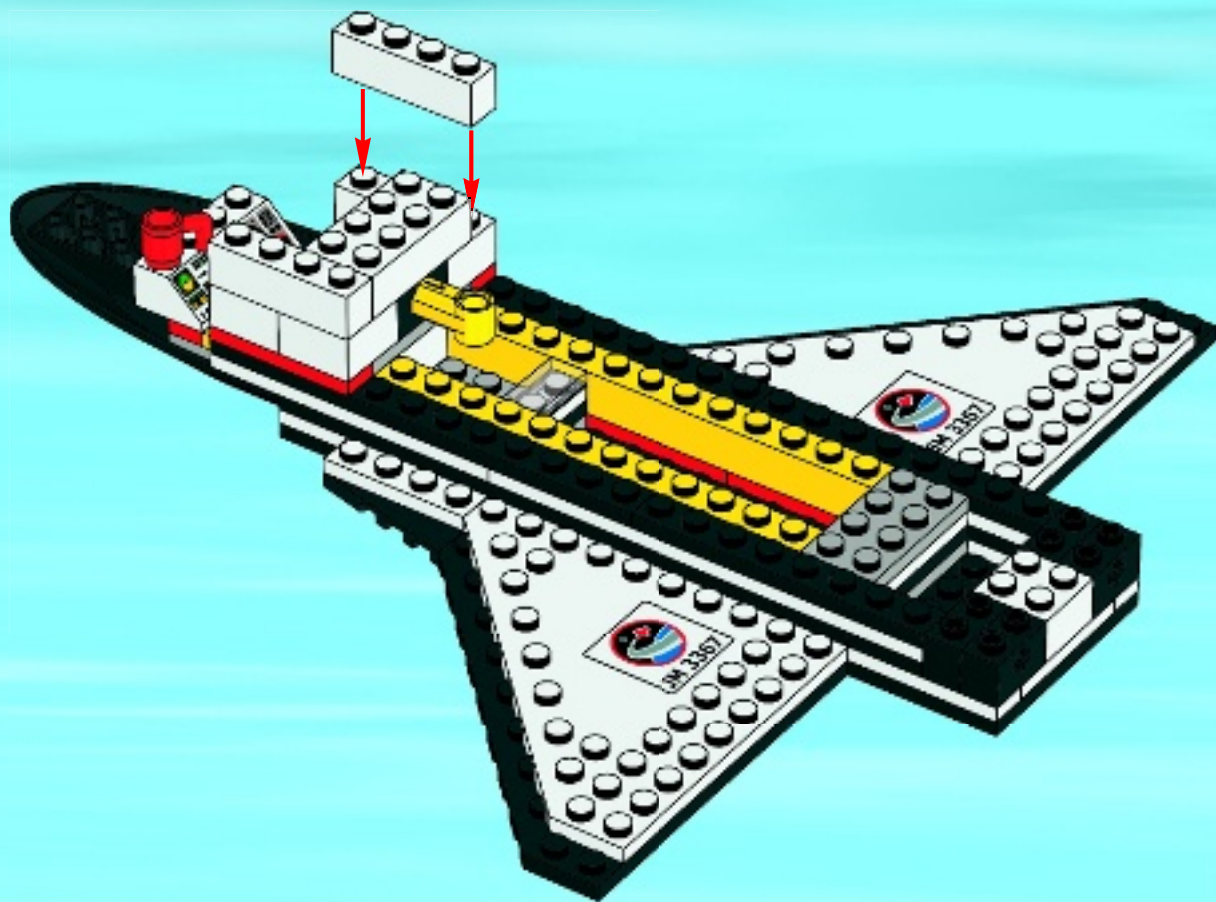

26

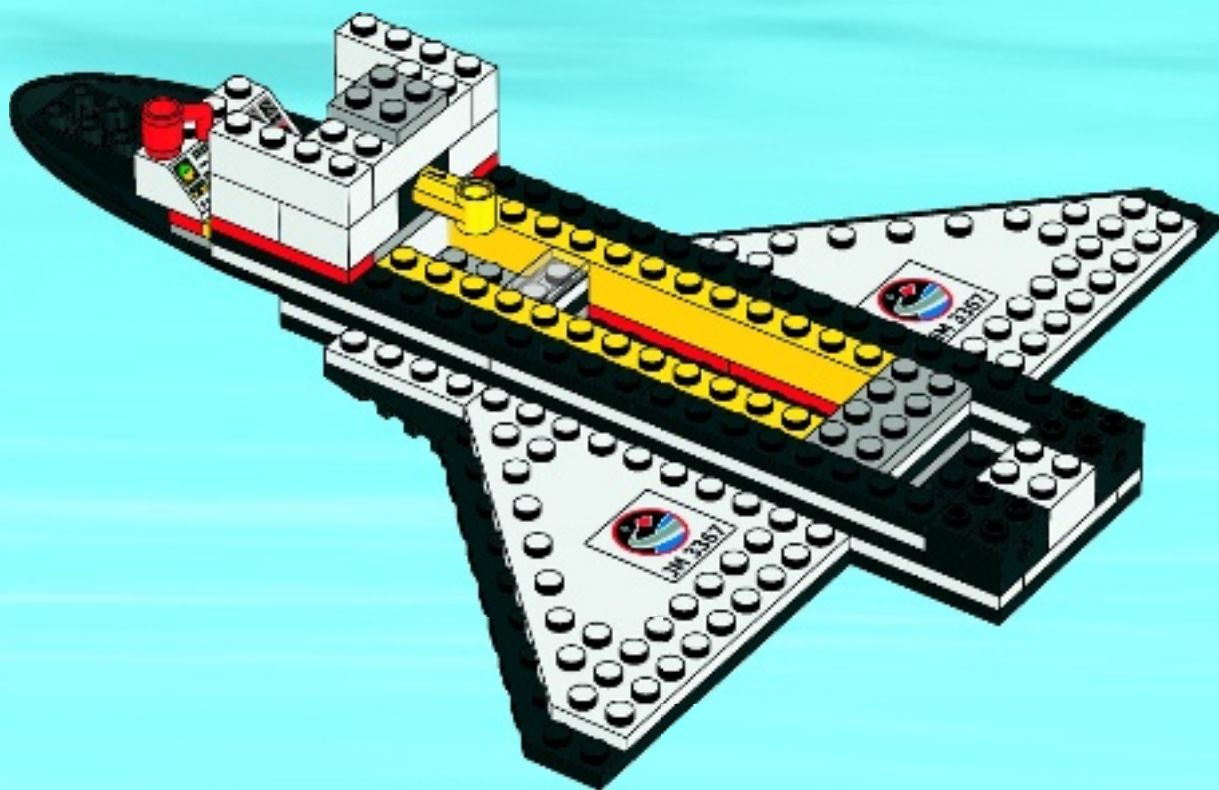

27

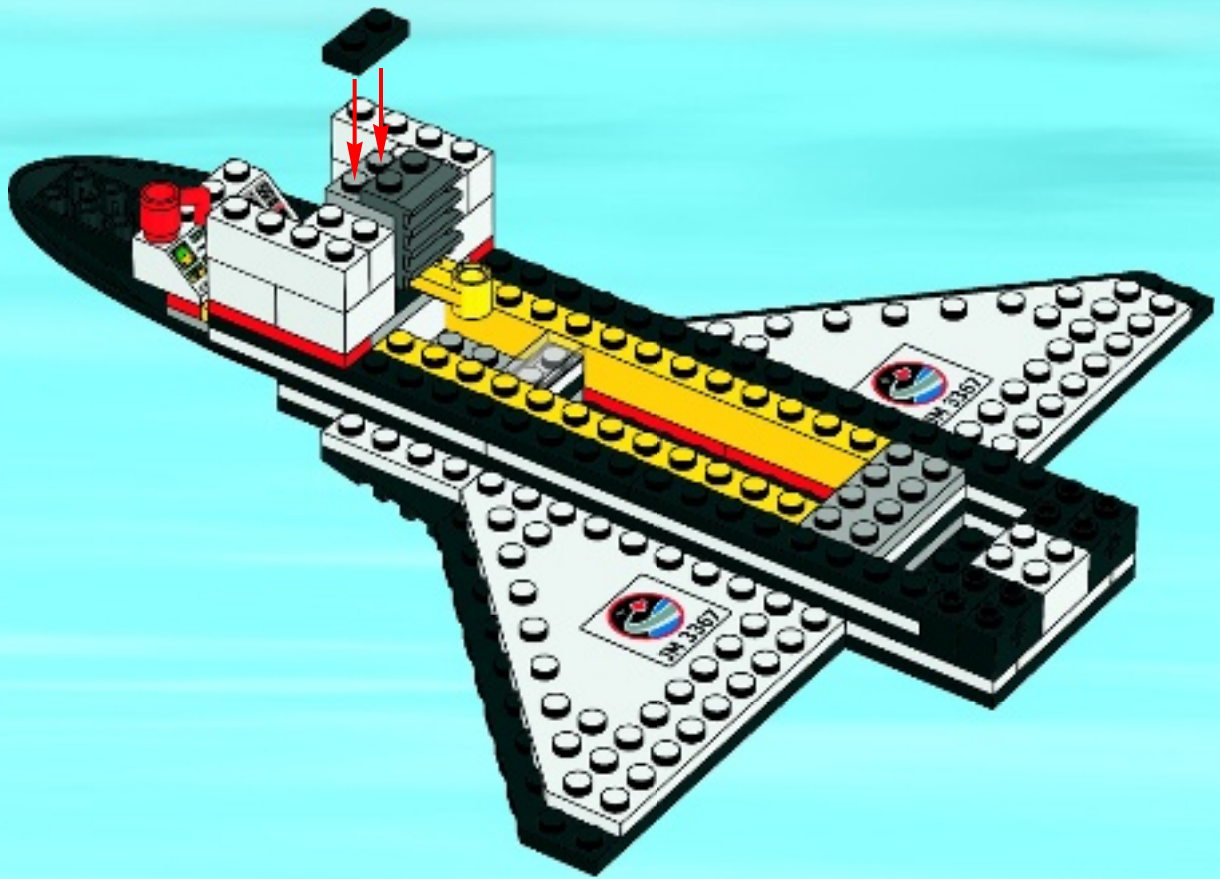

28

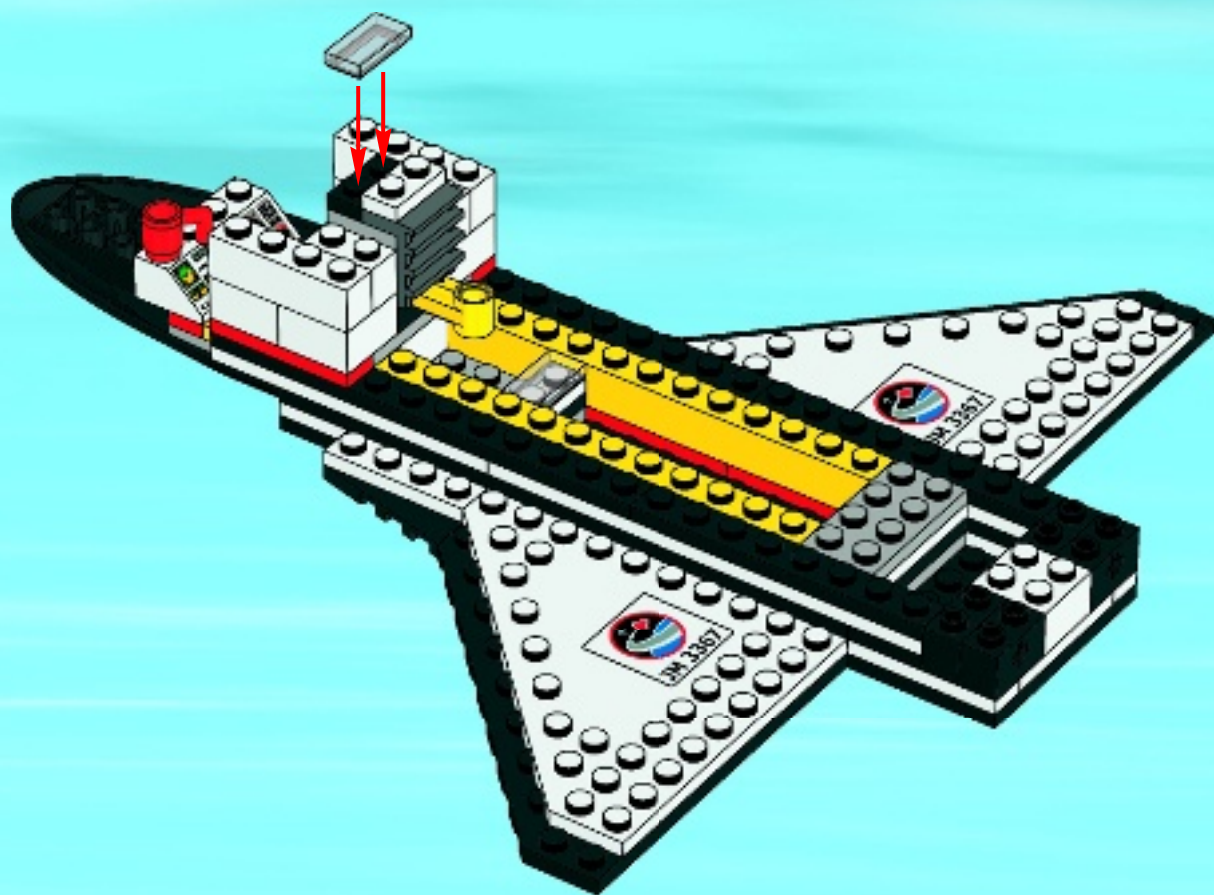



29

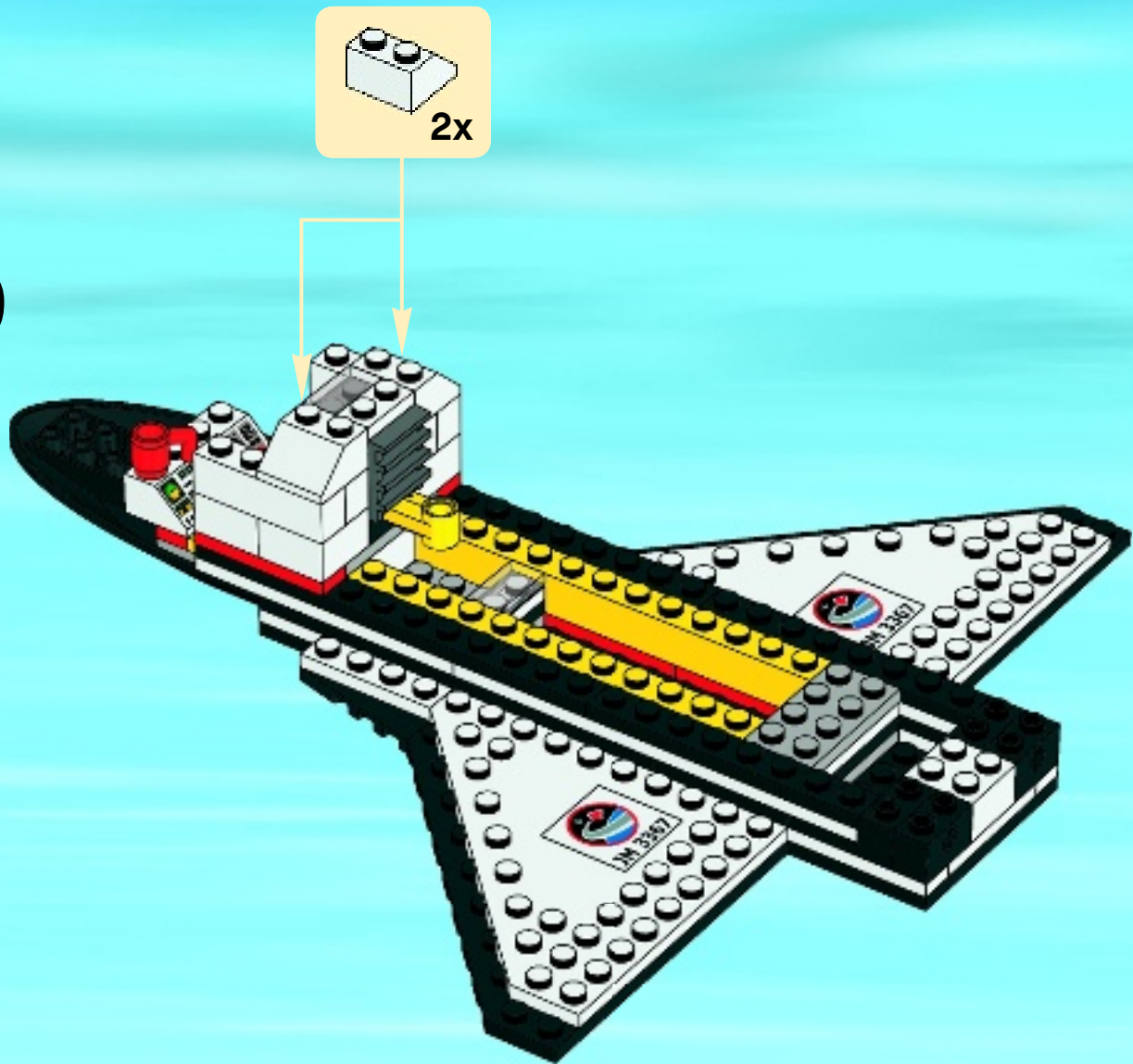

1

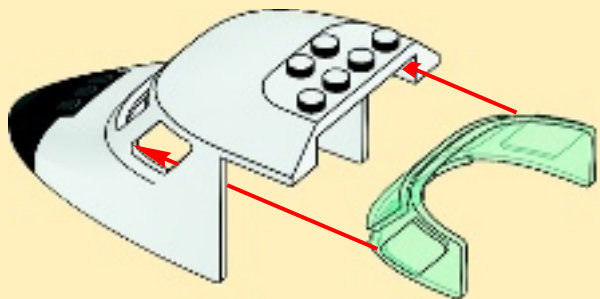

2



30

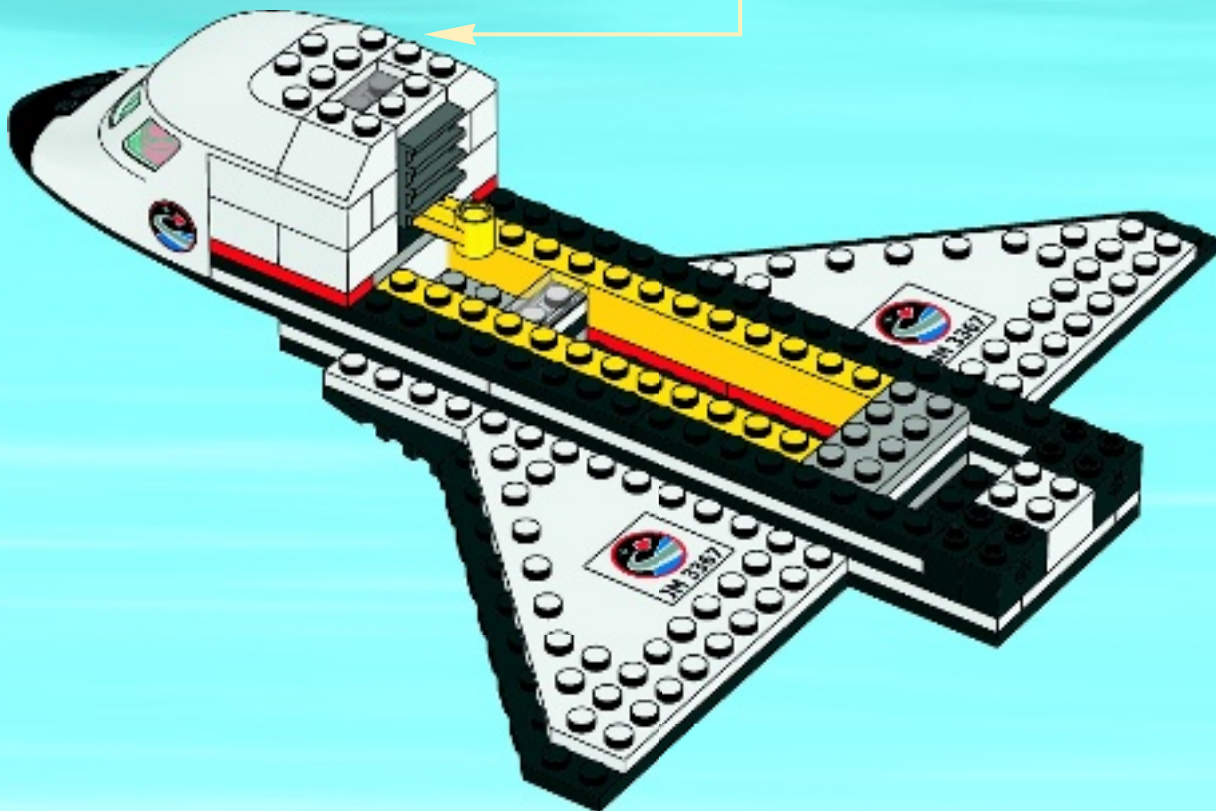

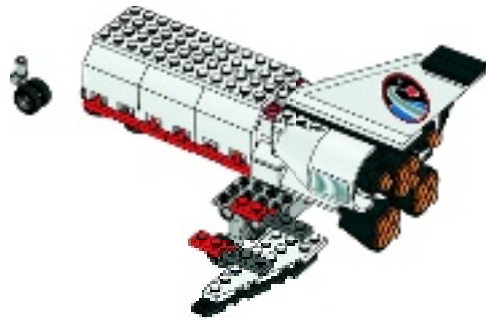

31

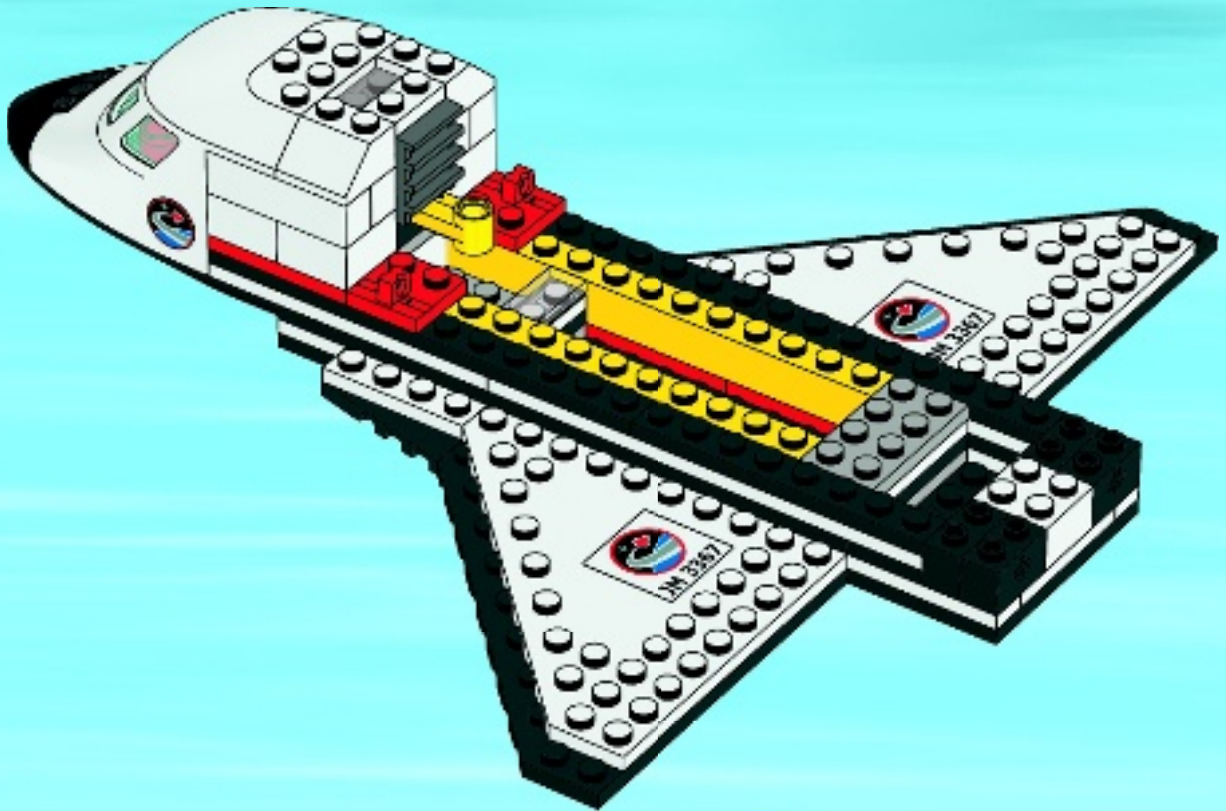

32

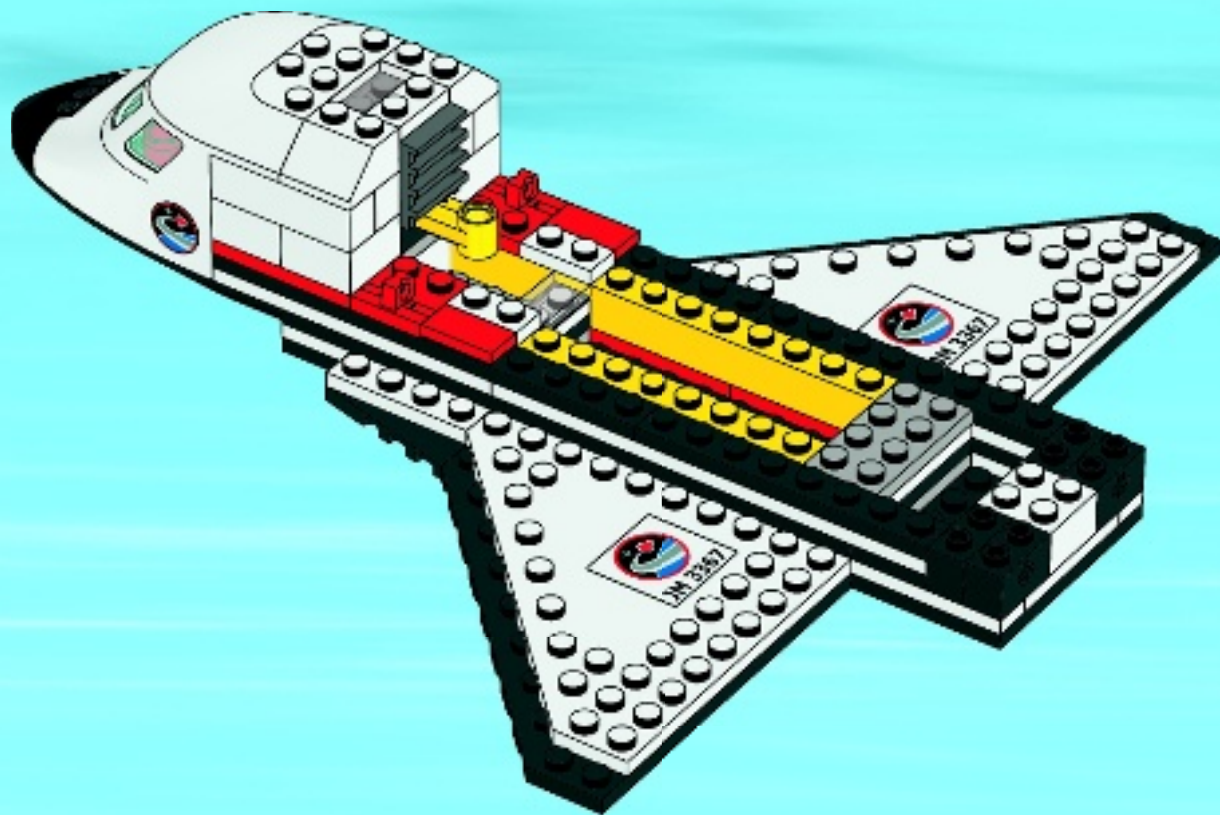



33

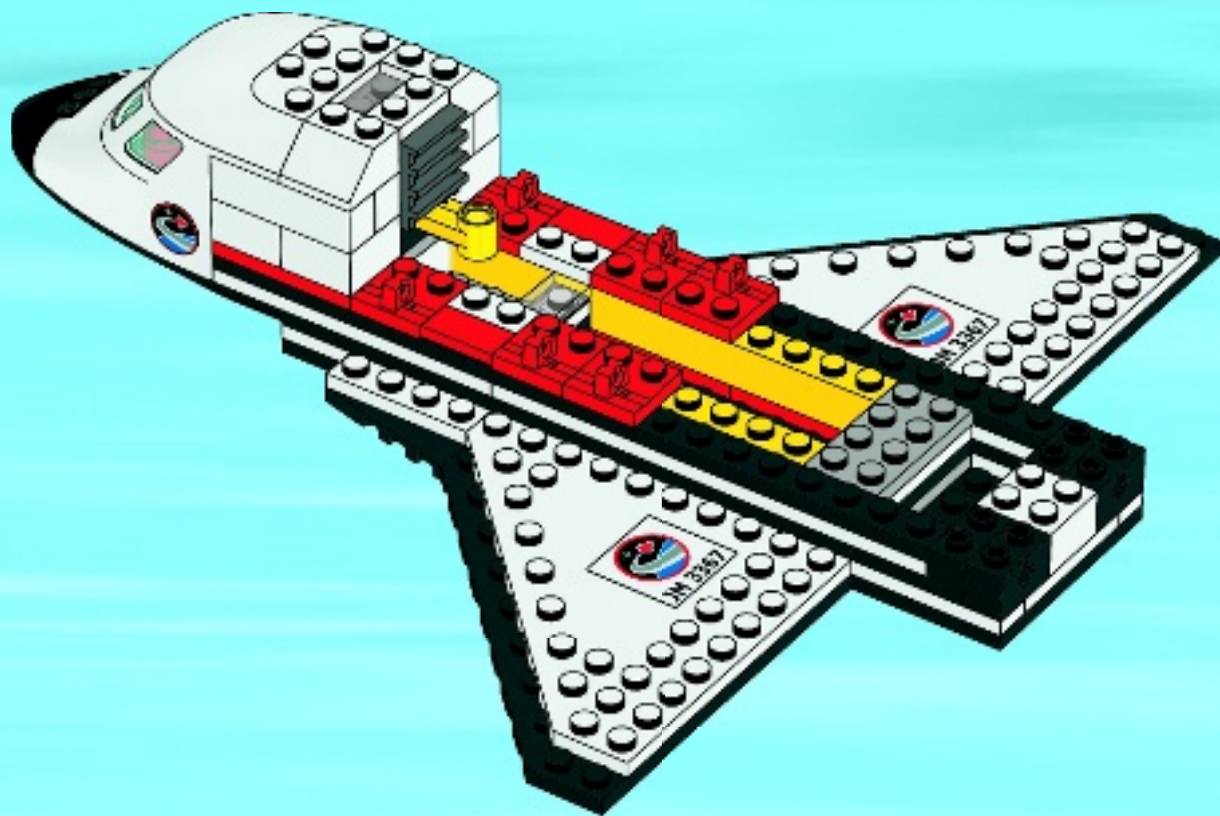

34

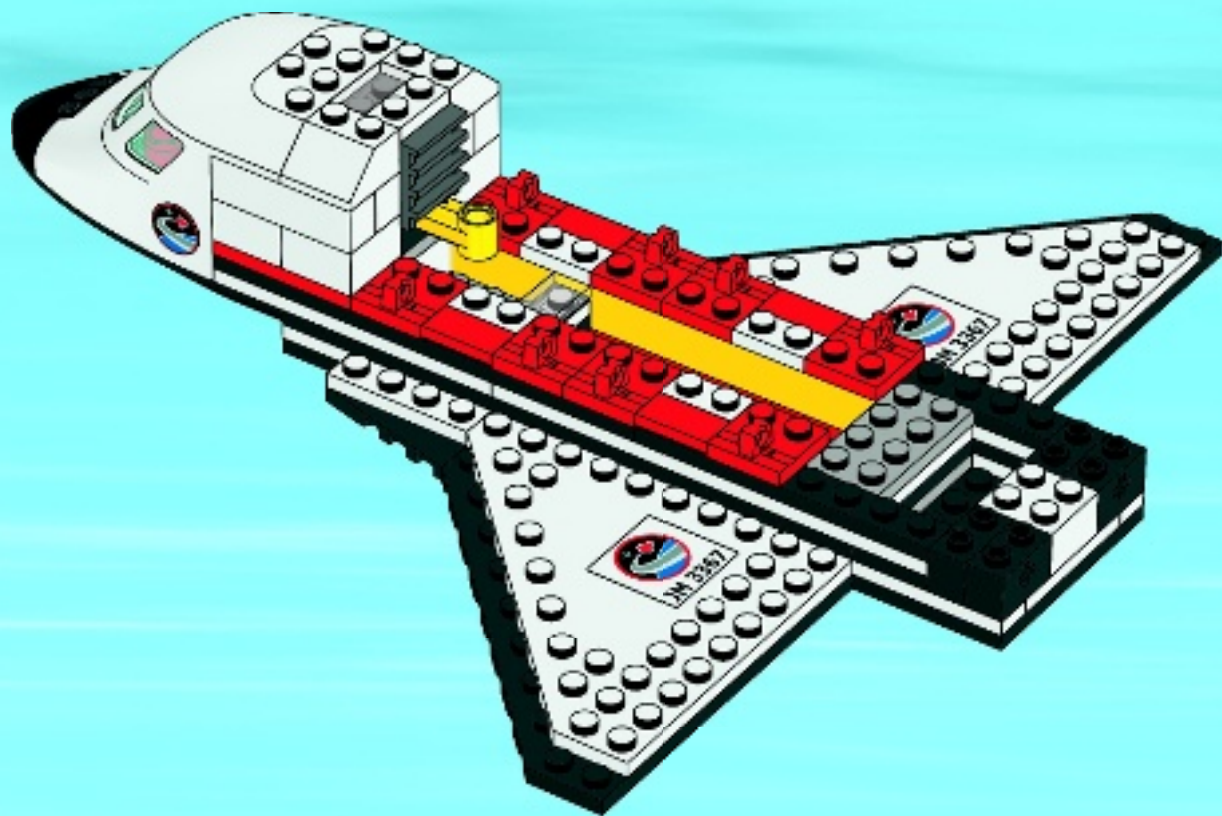

35

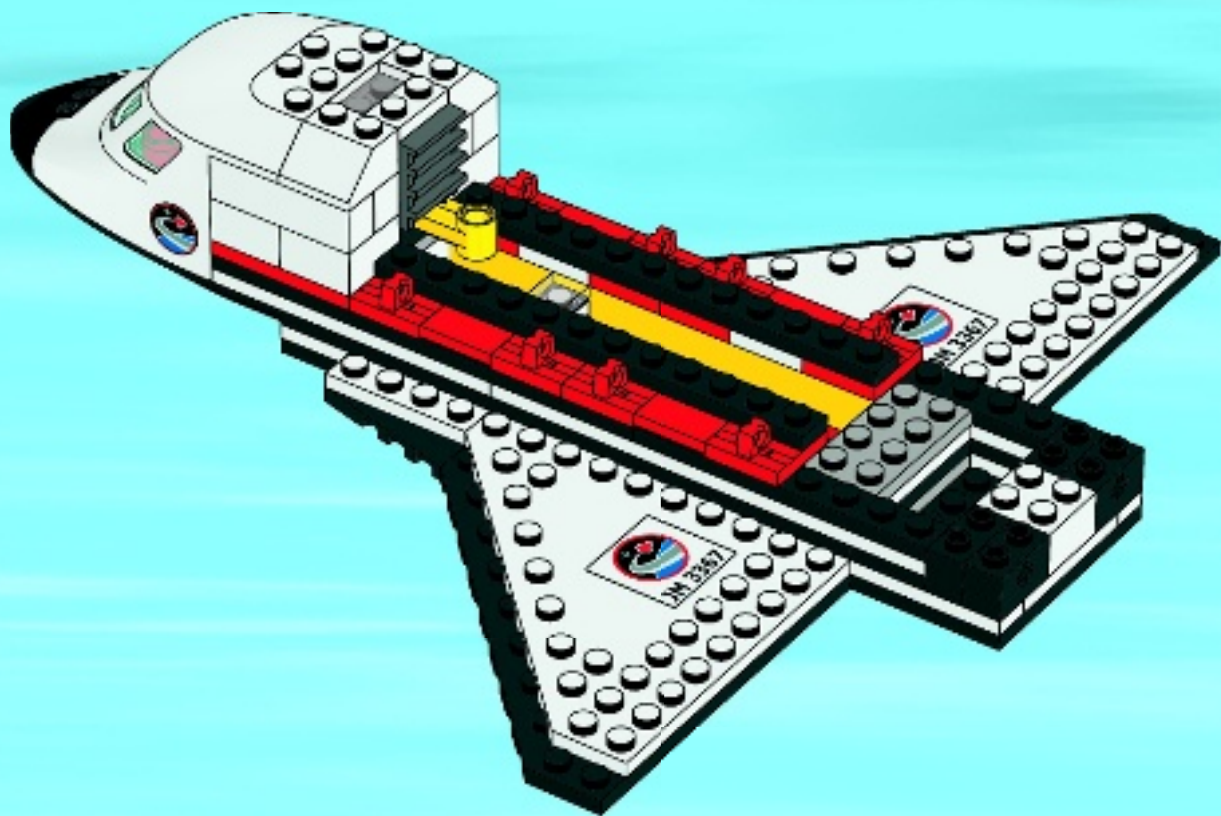

36

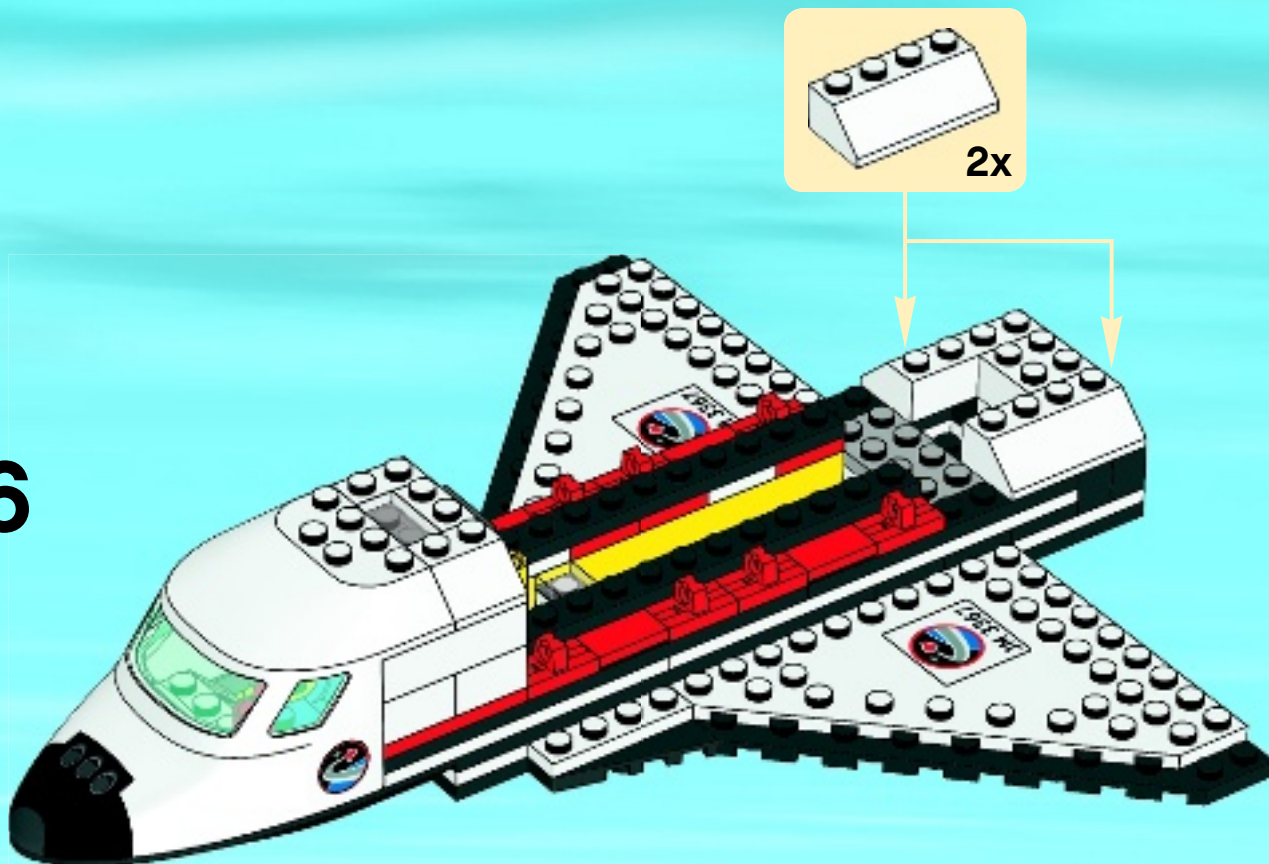



1

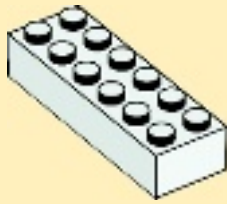

2

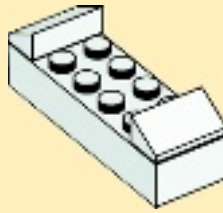

37

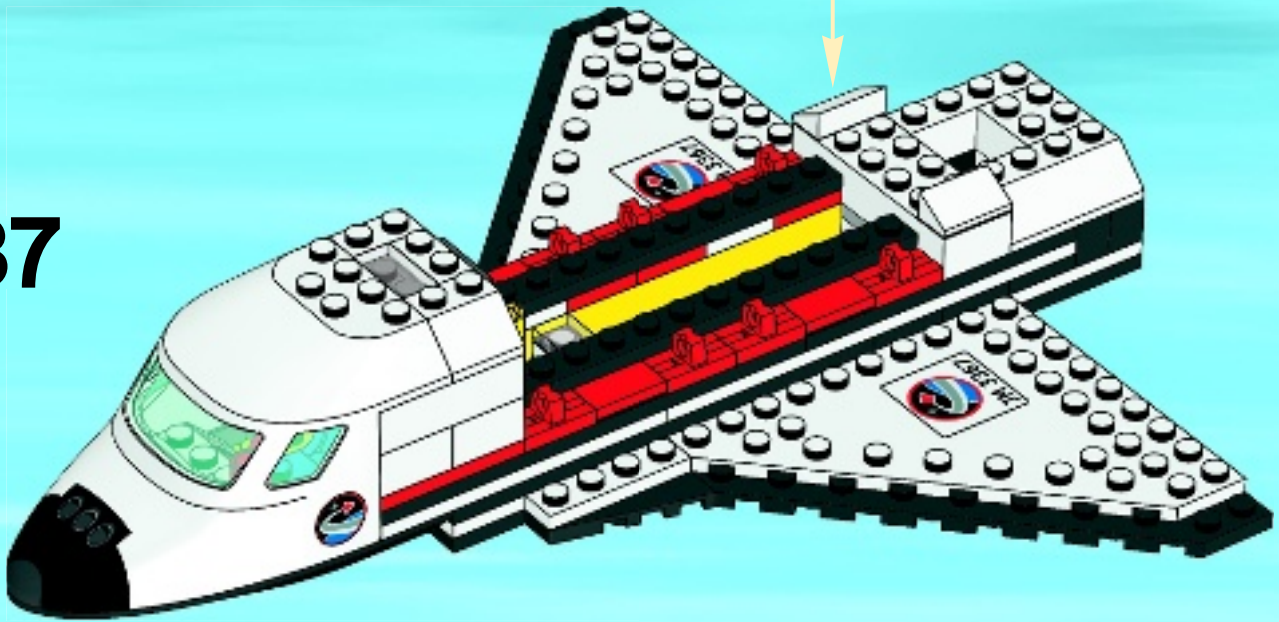

38

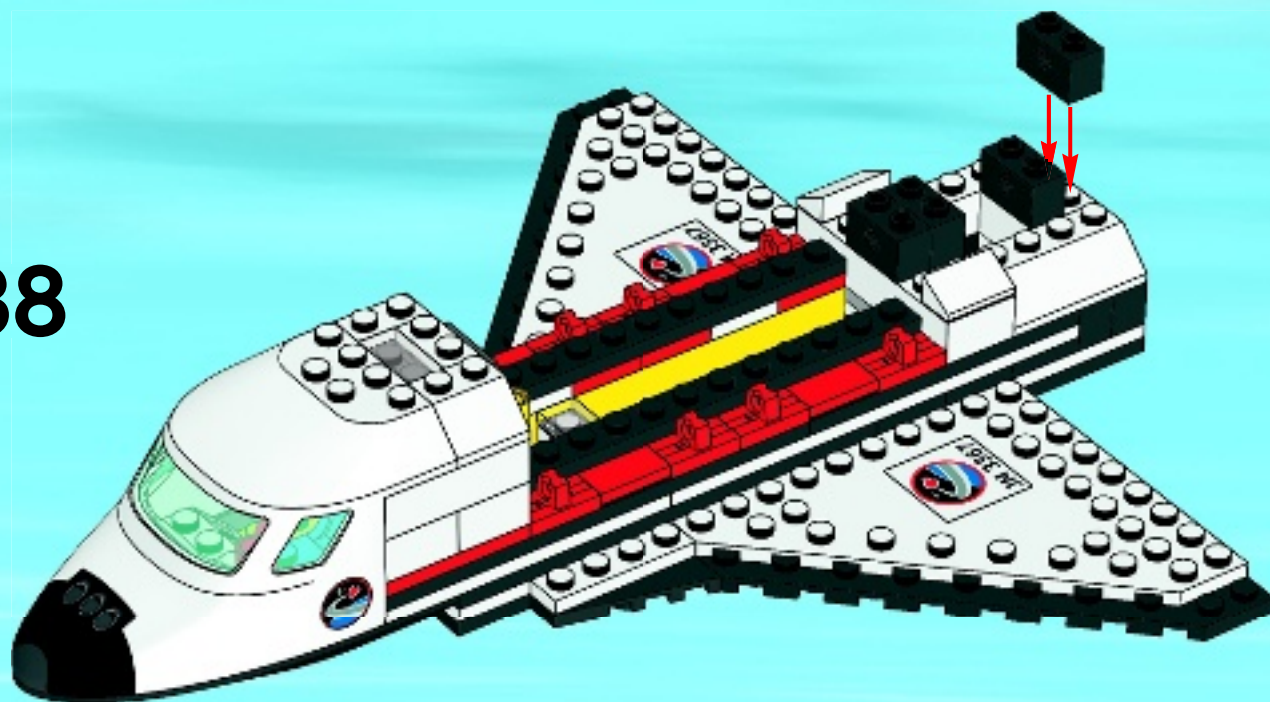

39

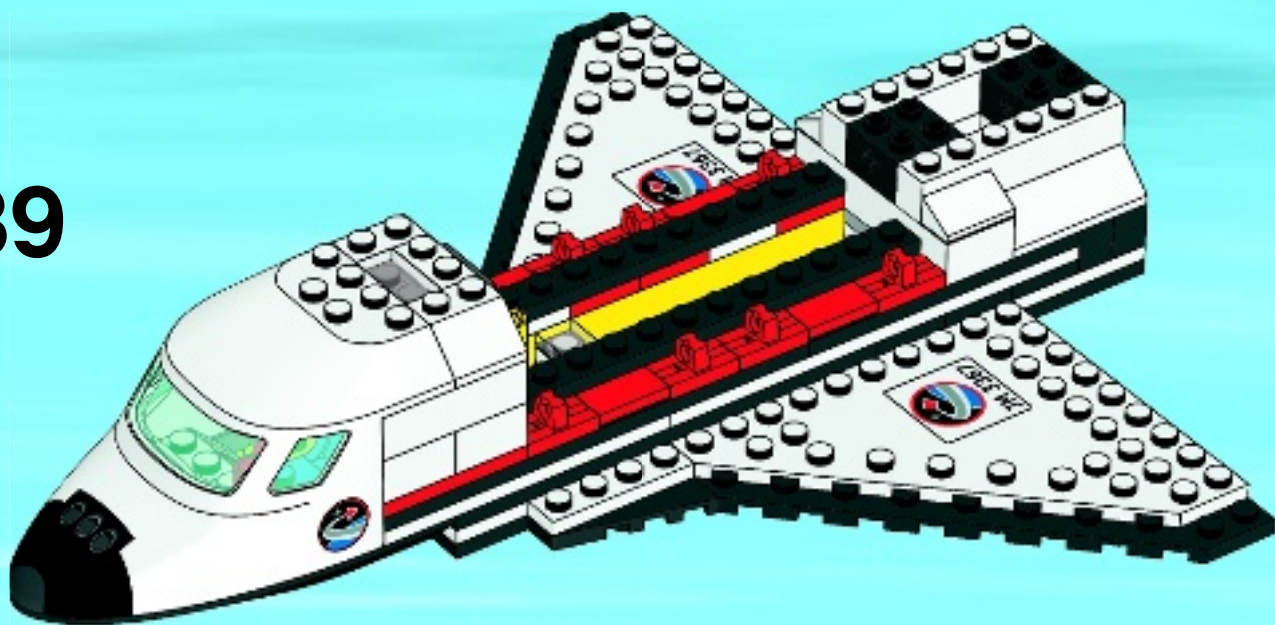

1



2

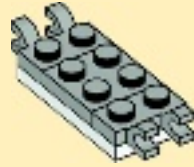

3

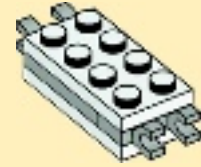

40

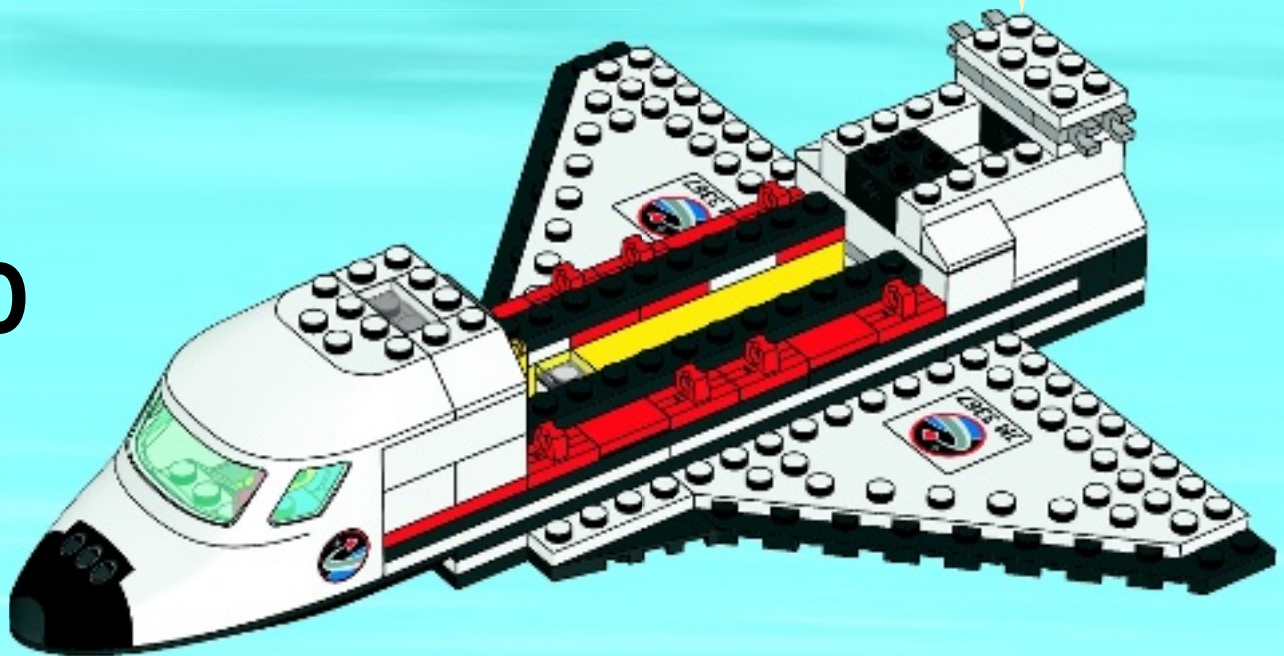



41

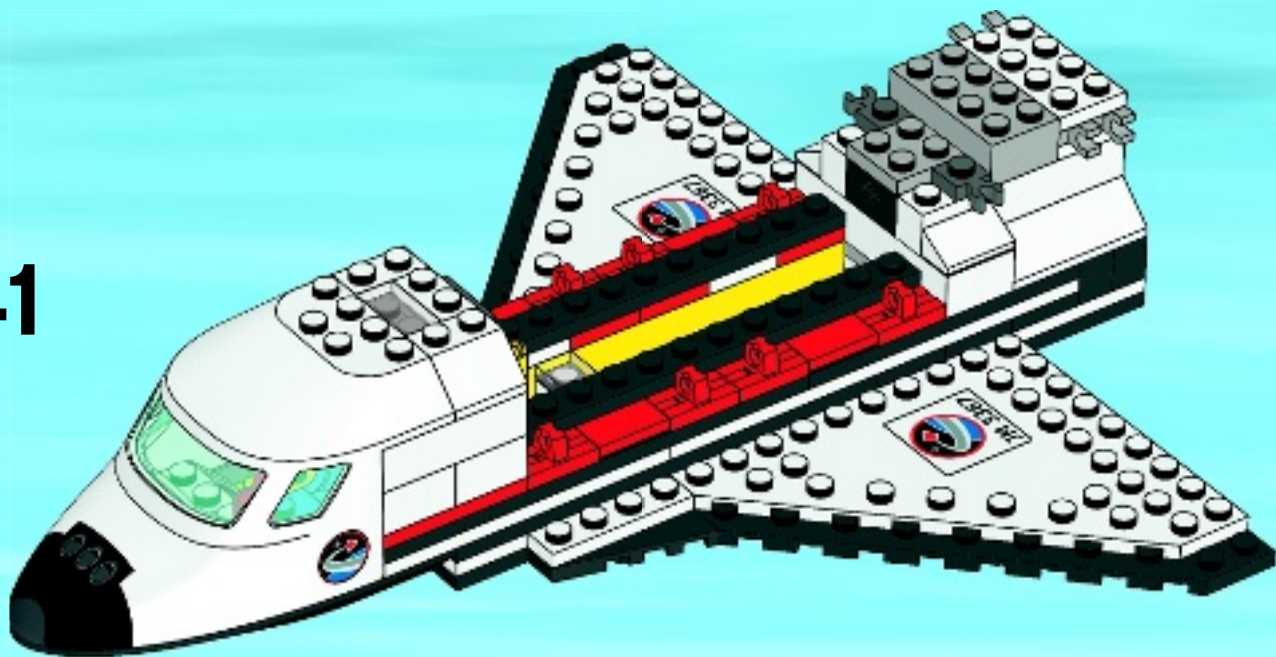

42

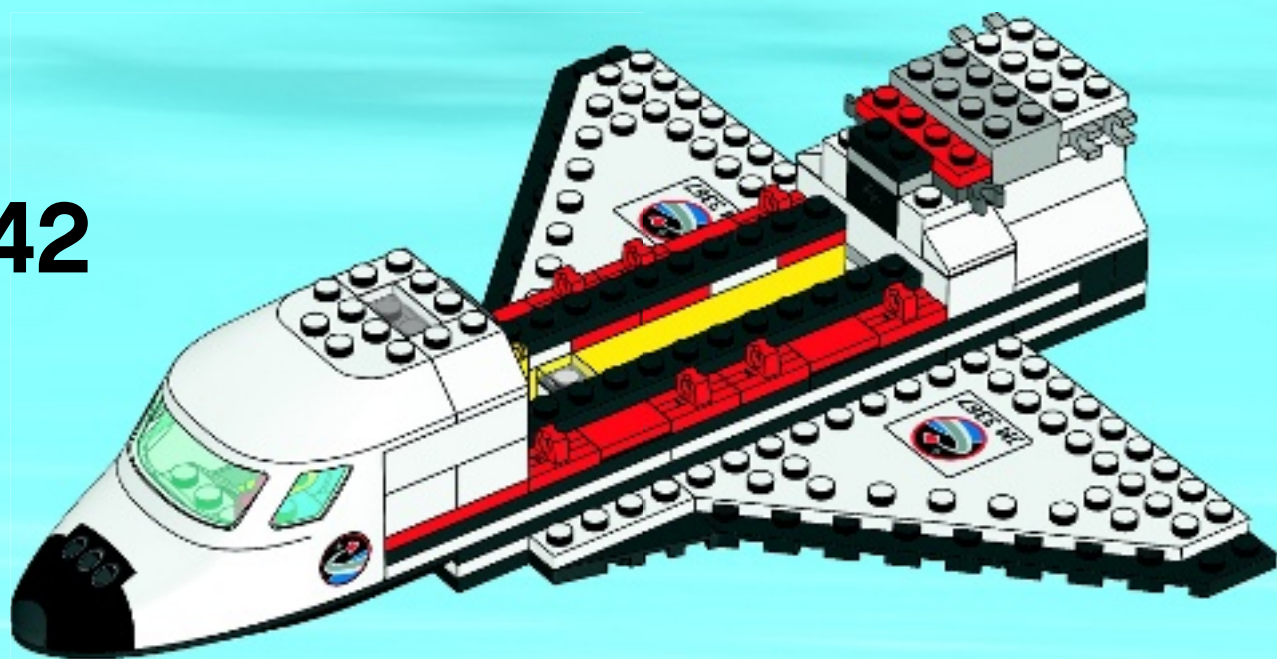

43

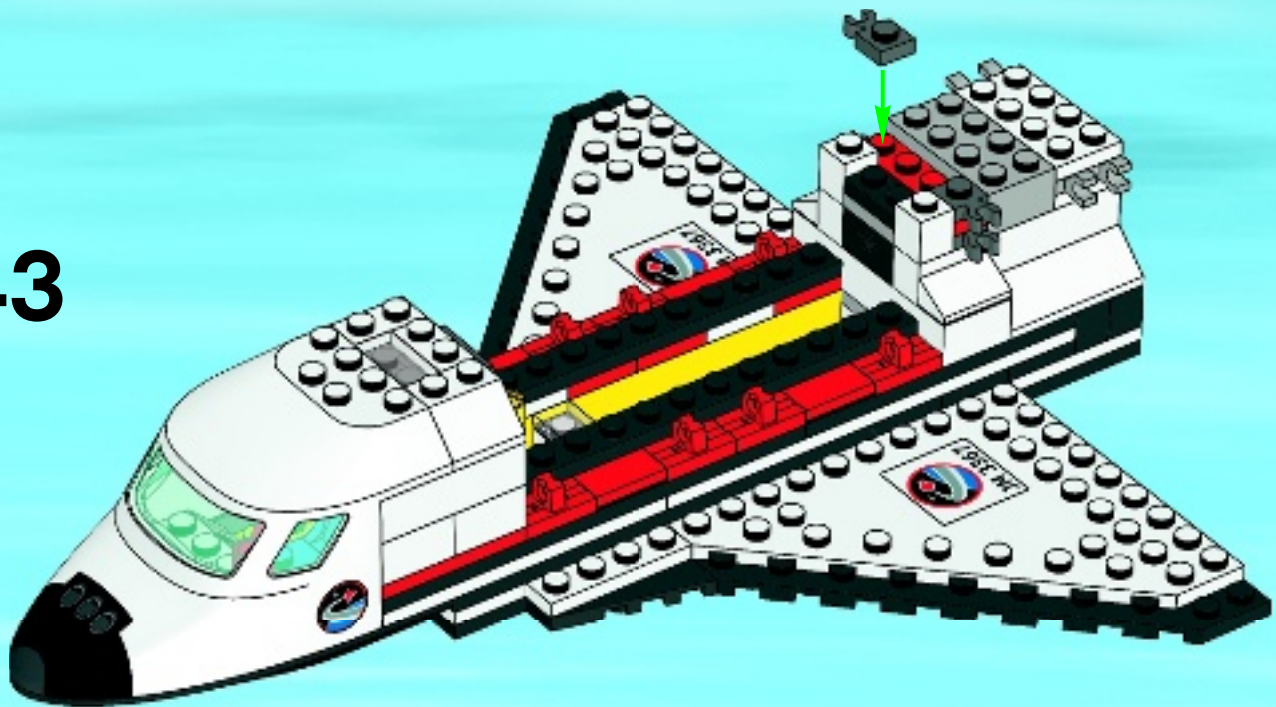

44

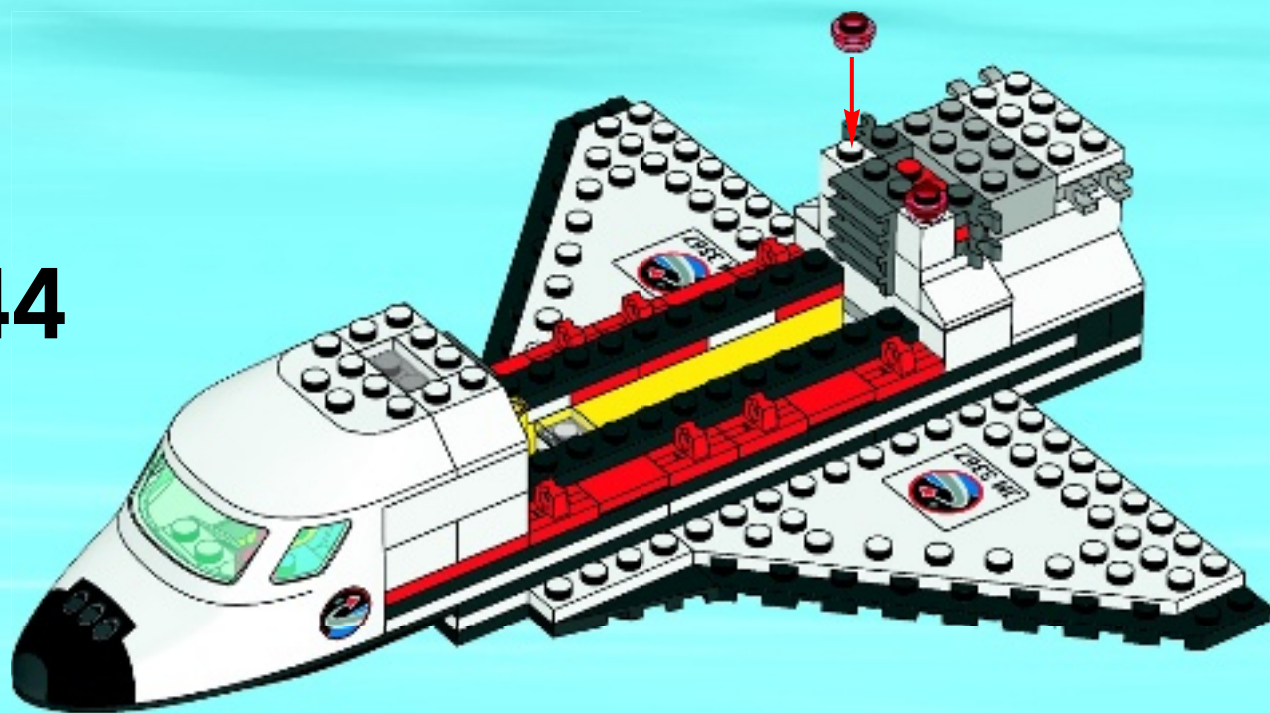



45

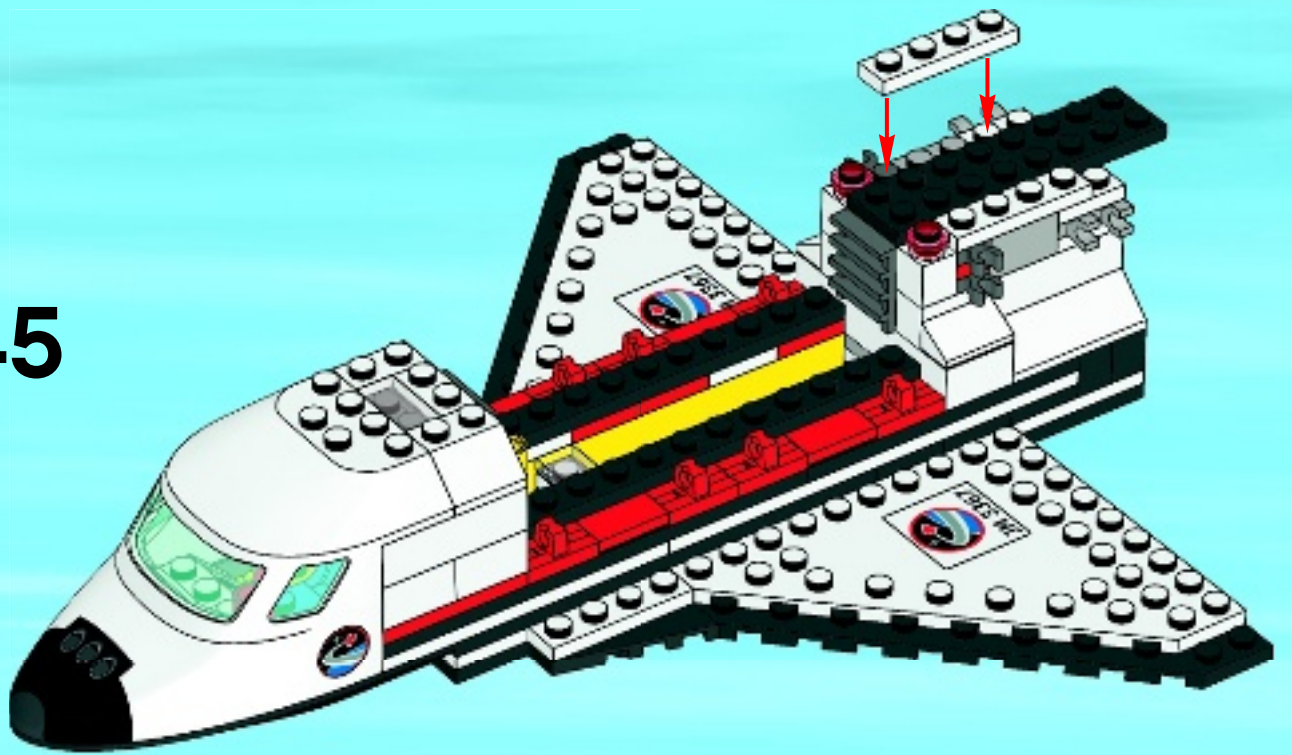

46

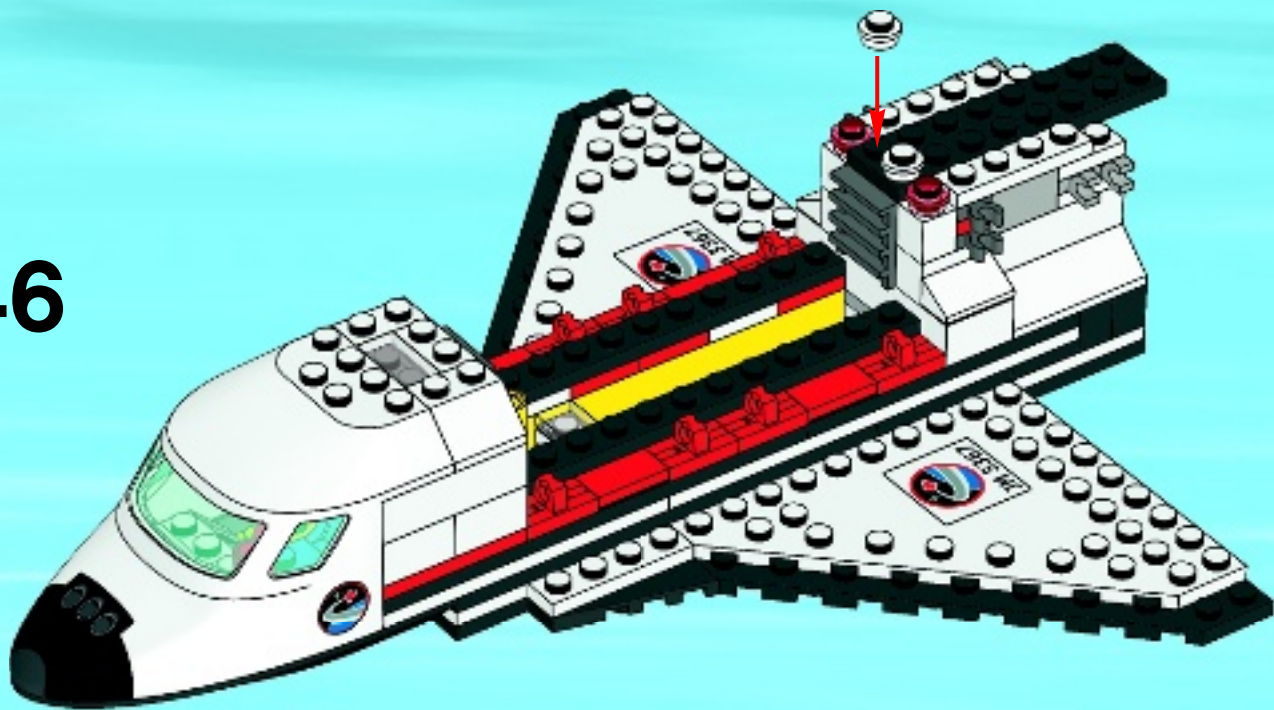

47

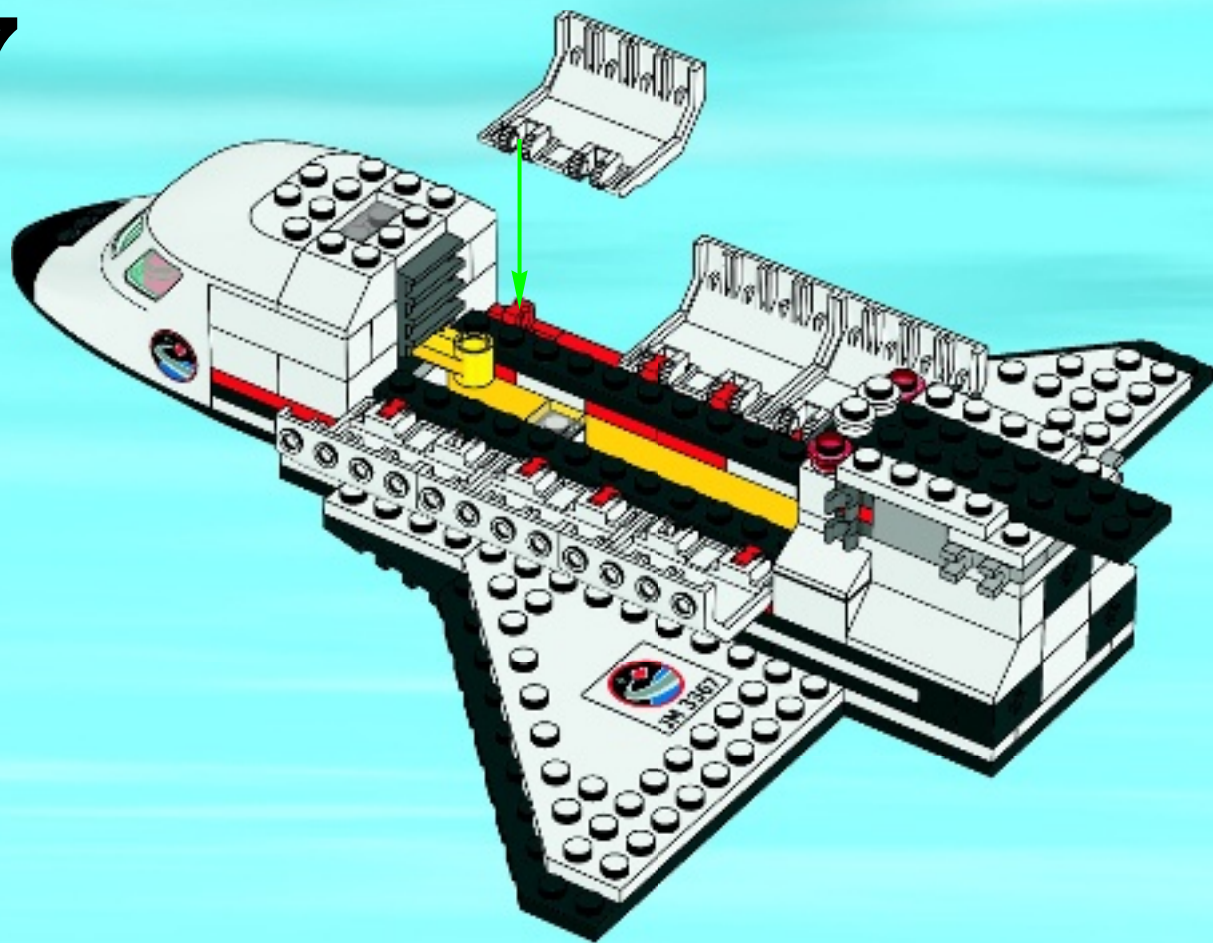



48

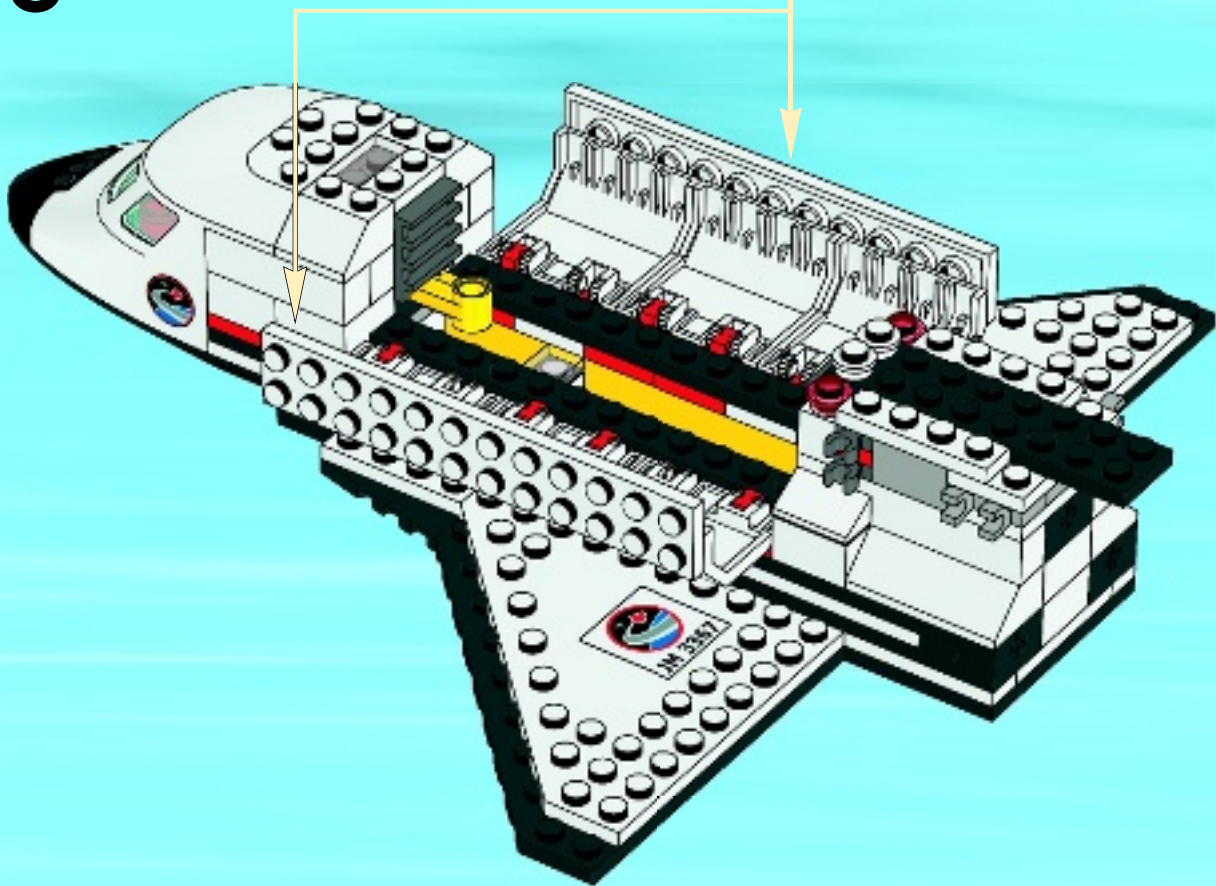
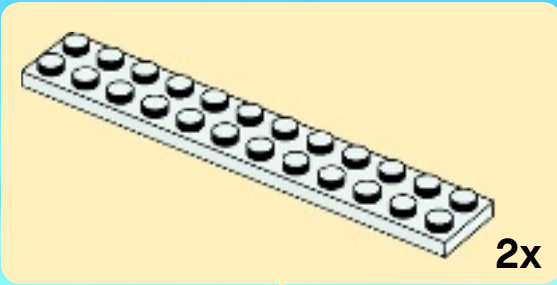



# 49

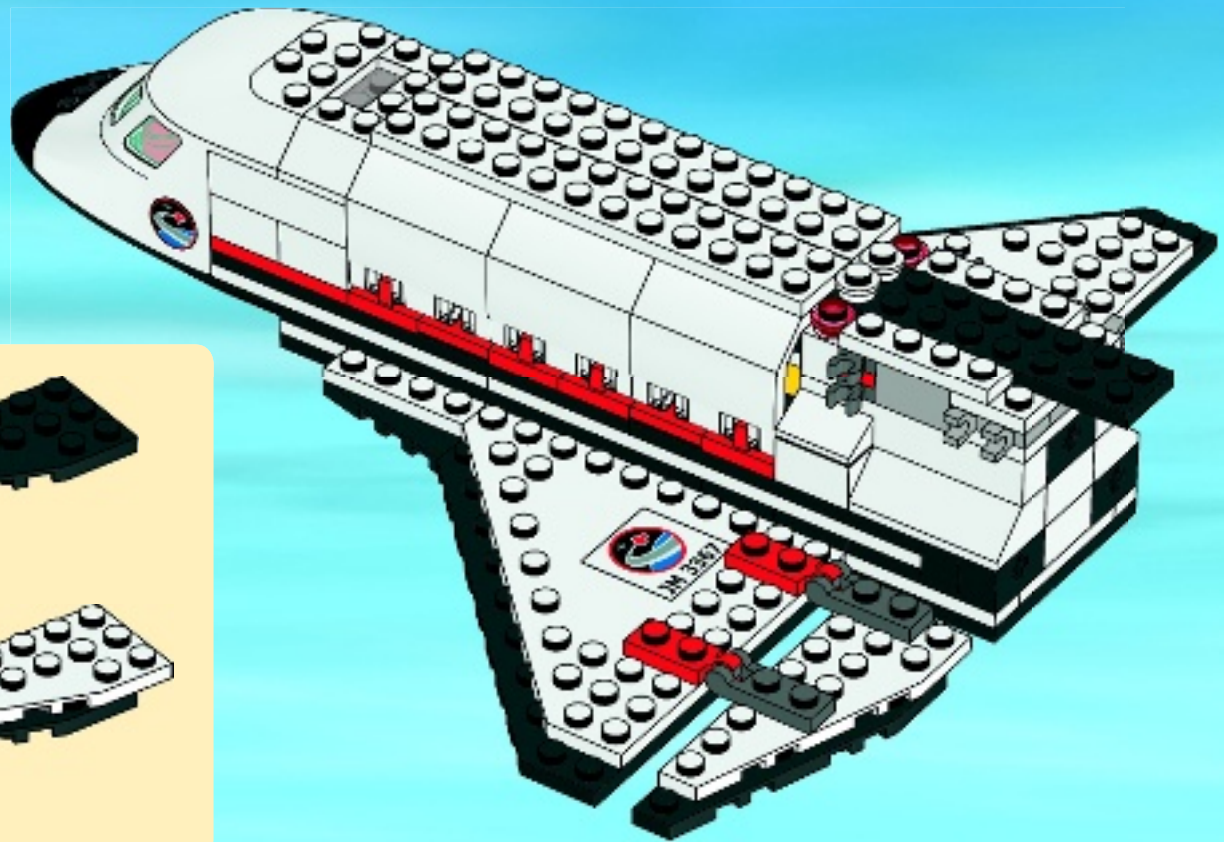

1



2

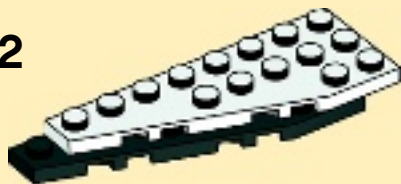

3

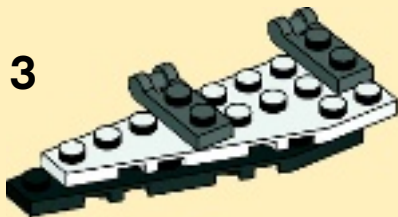

4

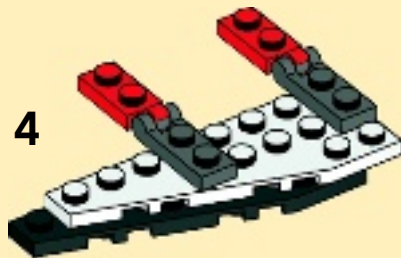

50

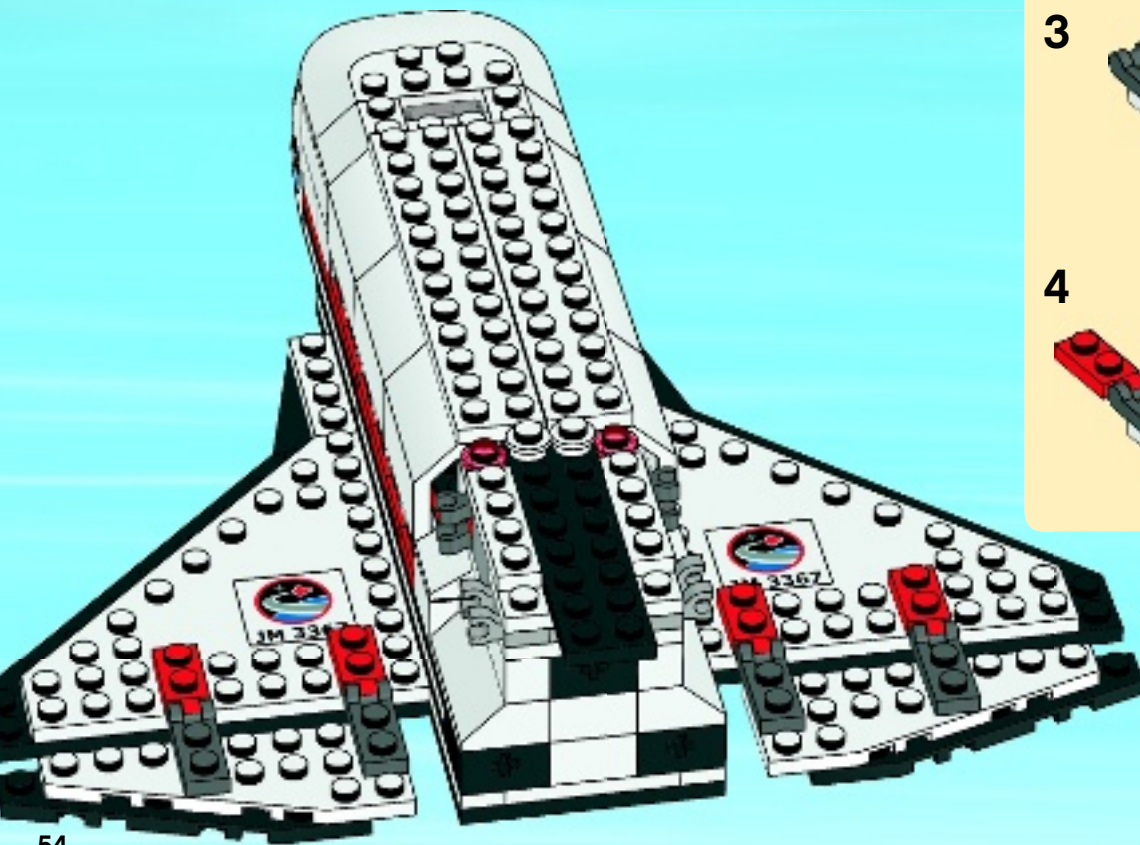

1



2



3



4



51

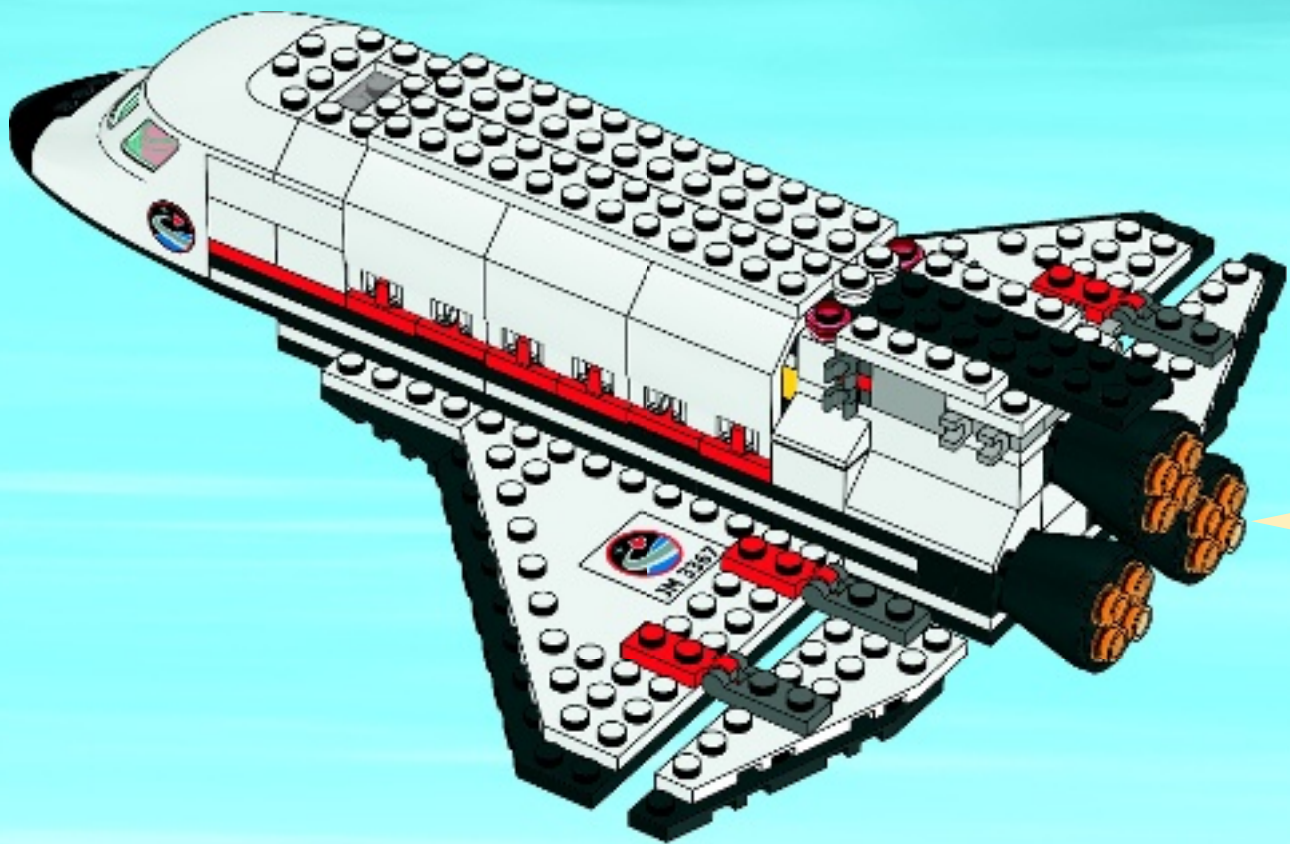



52

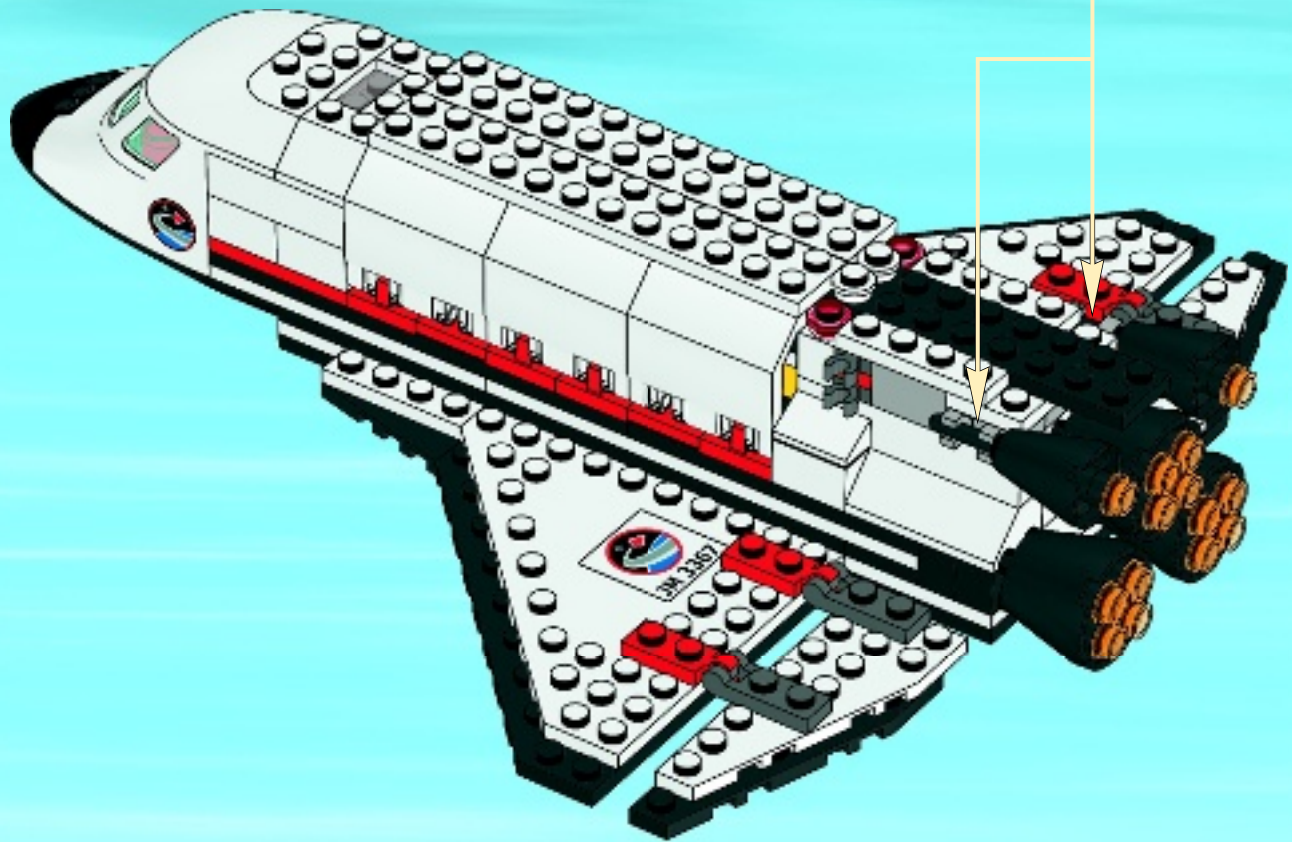
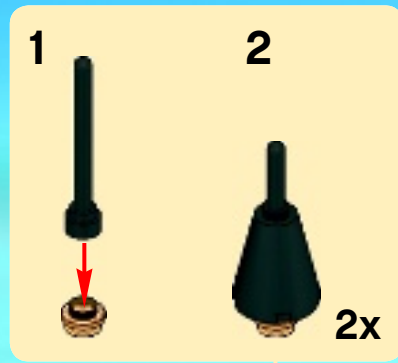



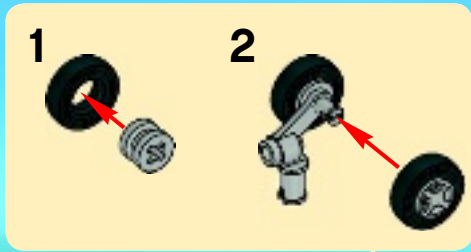

53

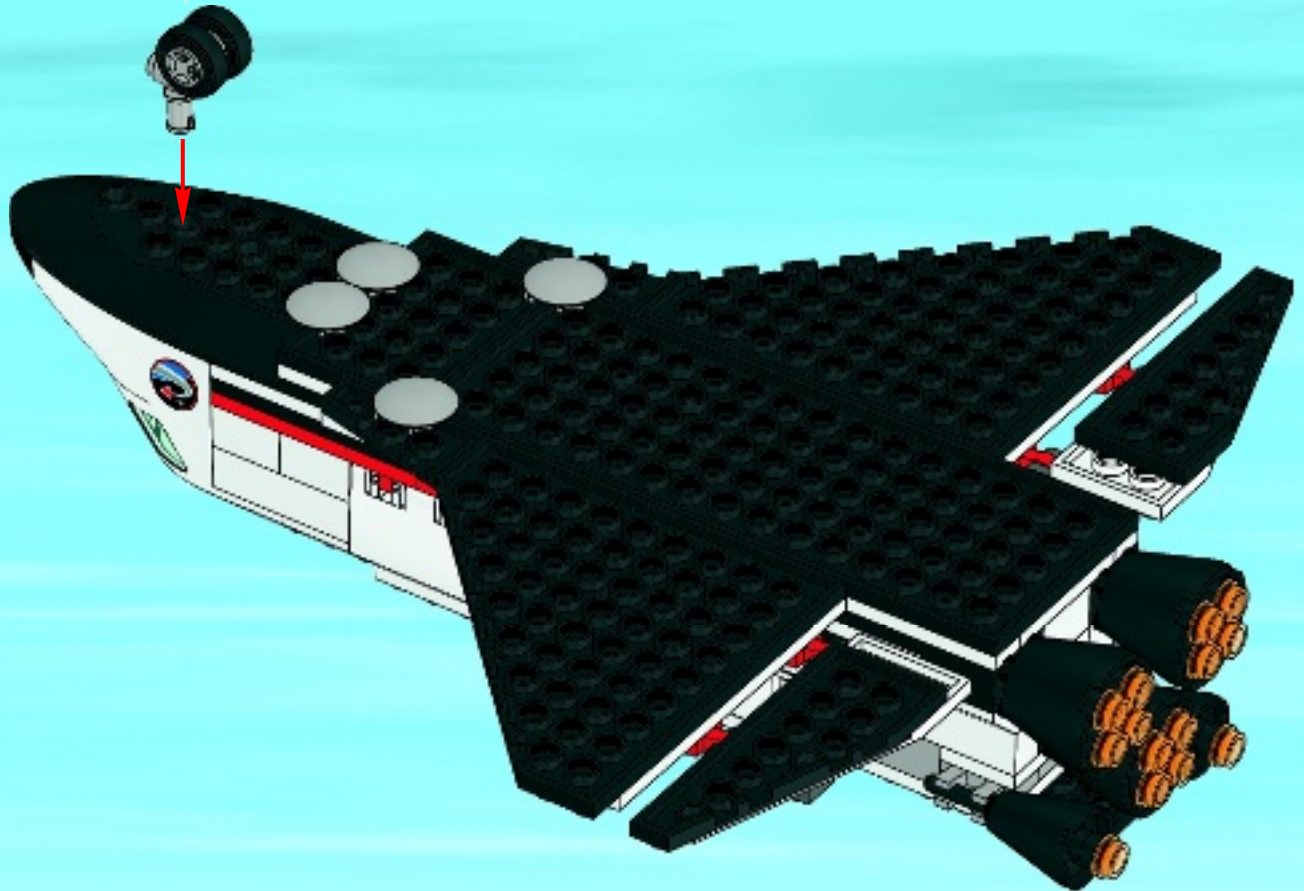

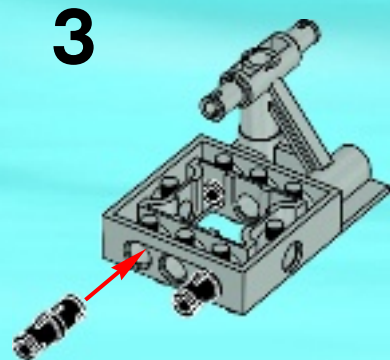
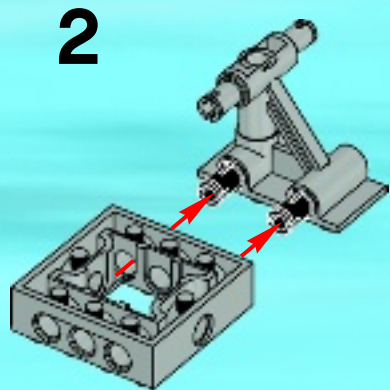
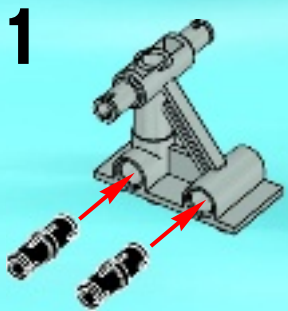

4

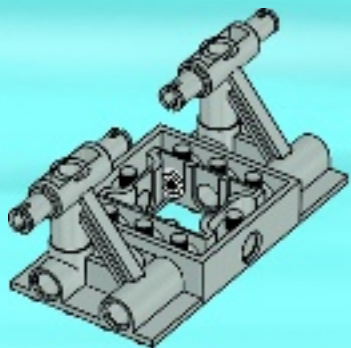

5

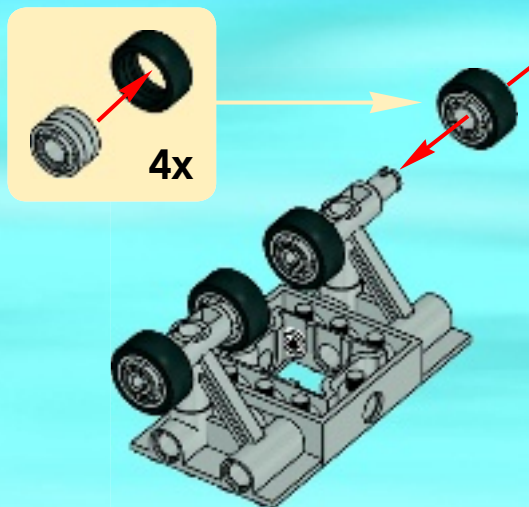

54

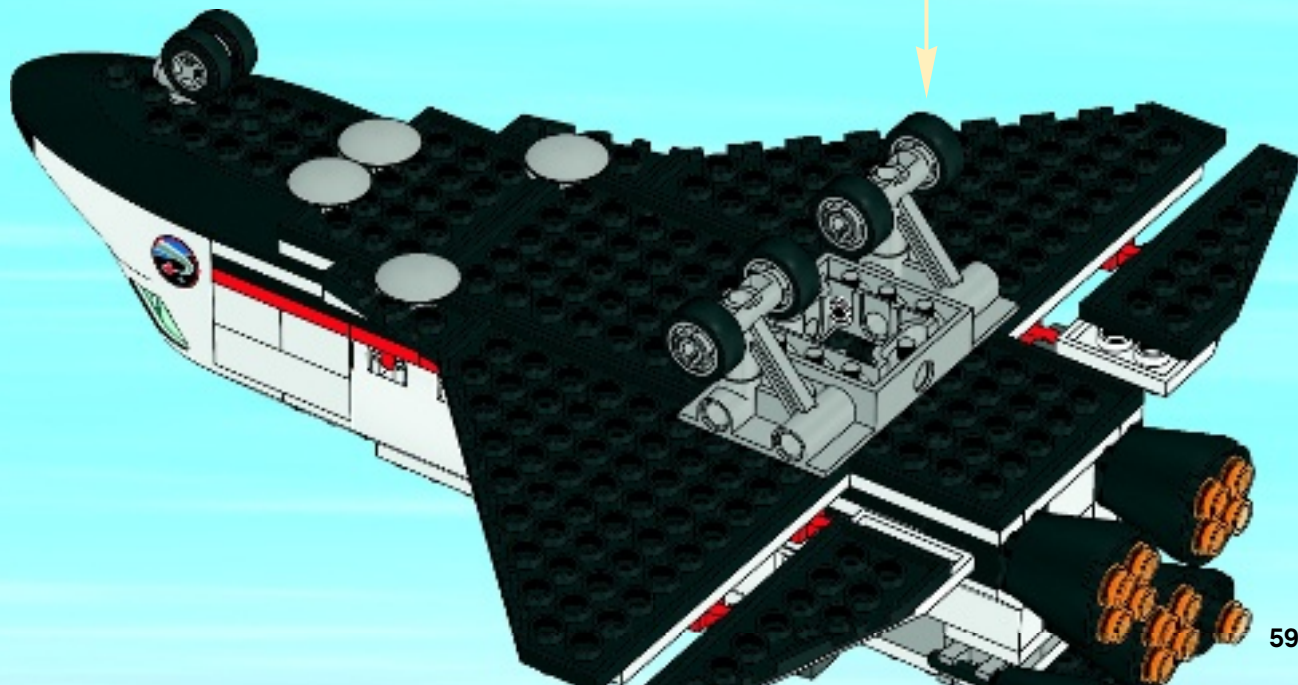



55

1

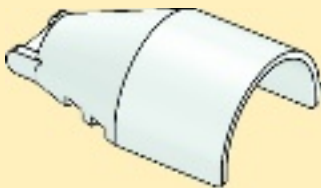

2

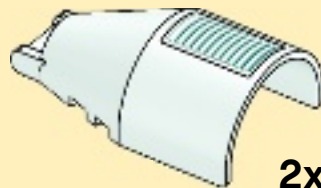

2x

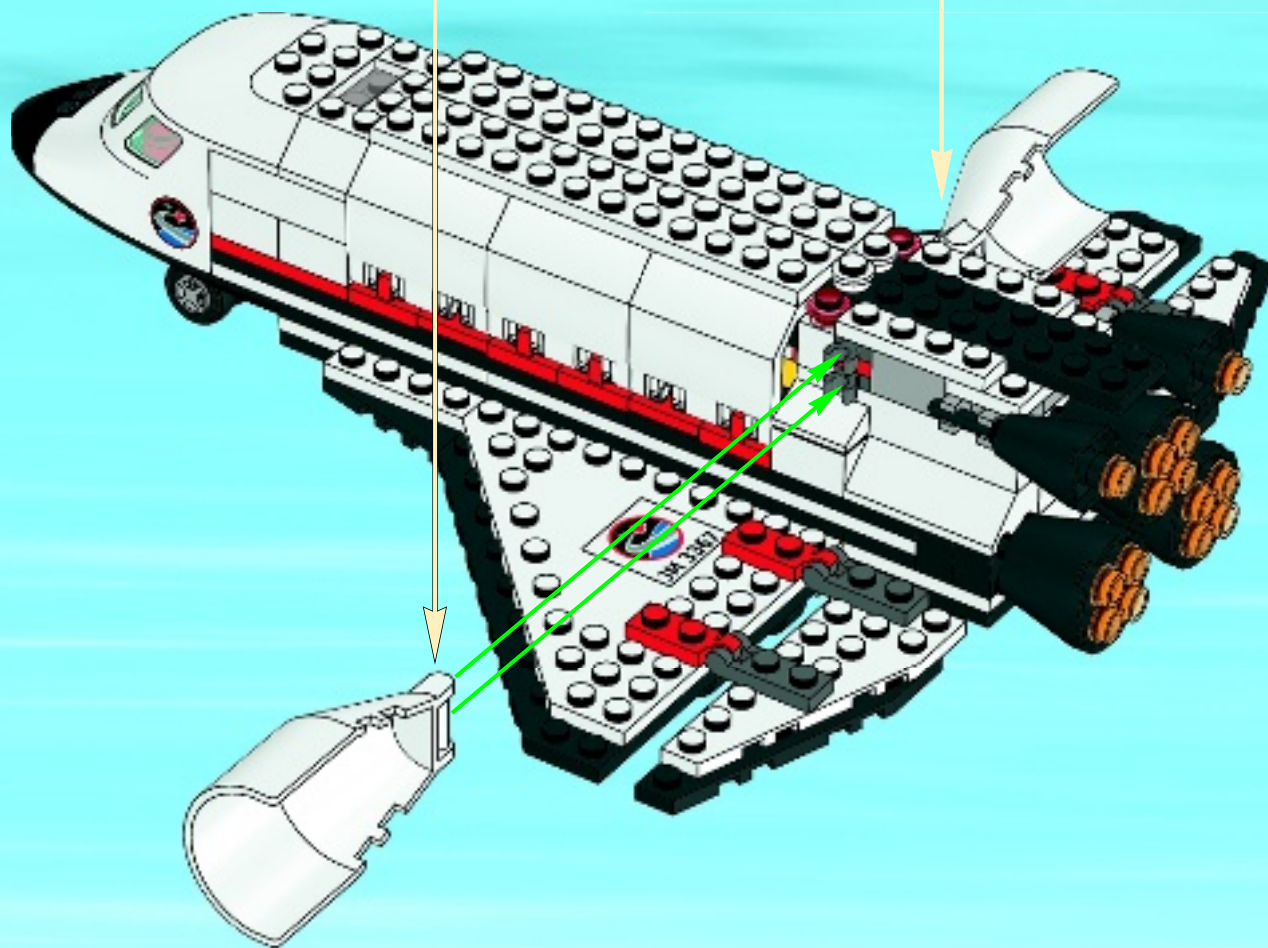



1

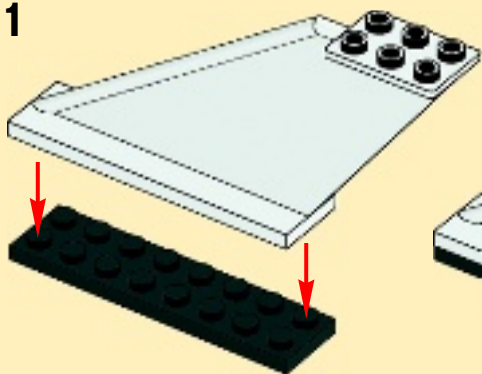

2

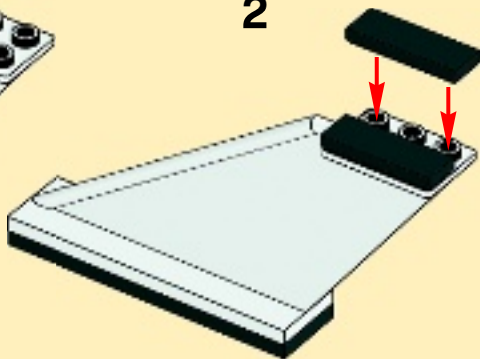

3

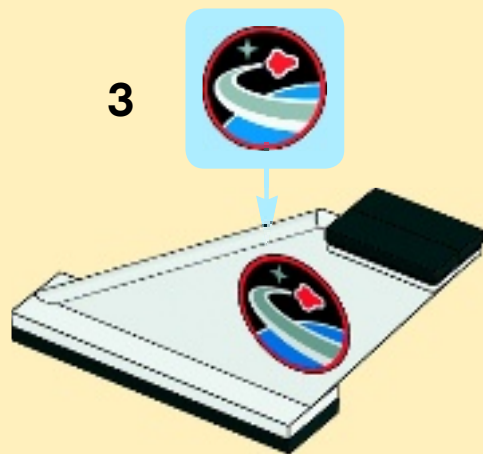

56

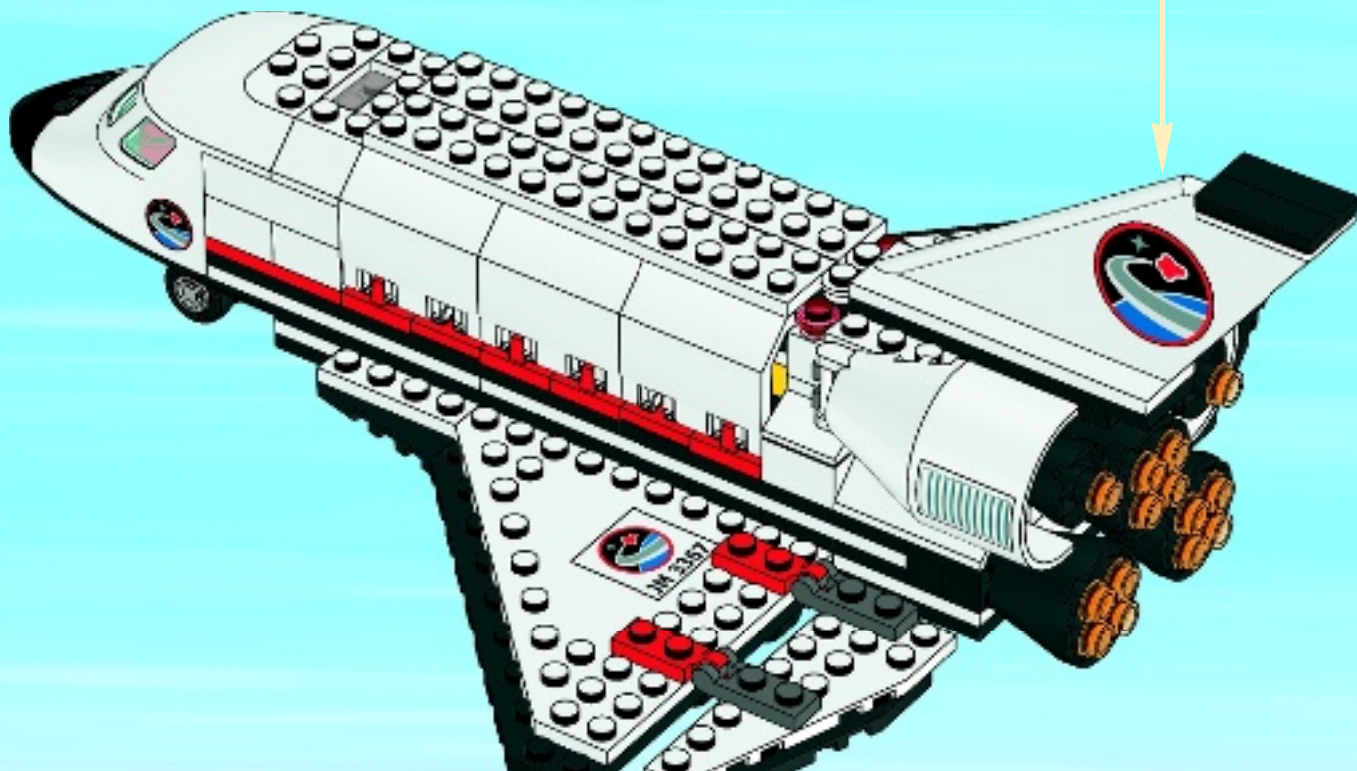

1

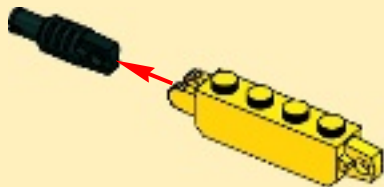

2

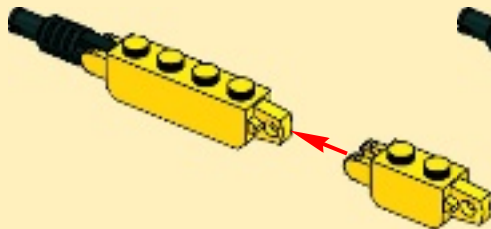

3

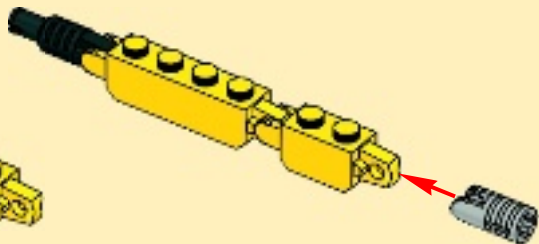

57

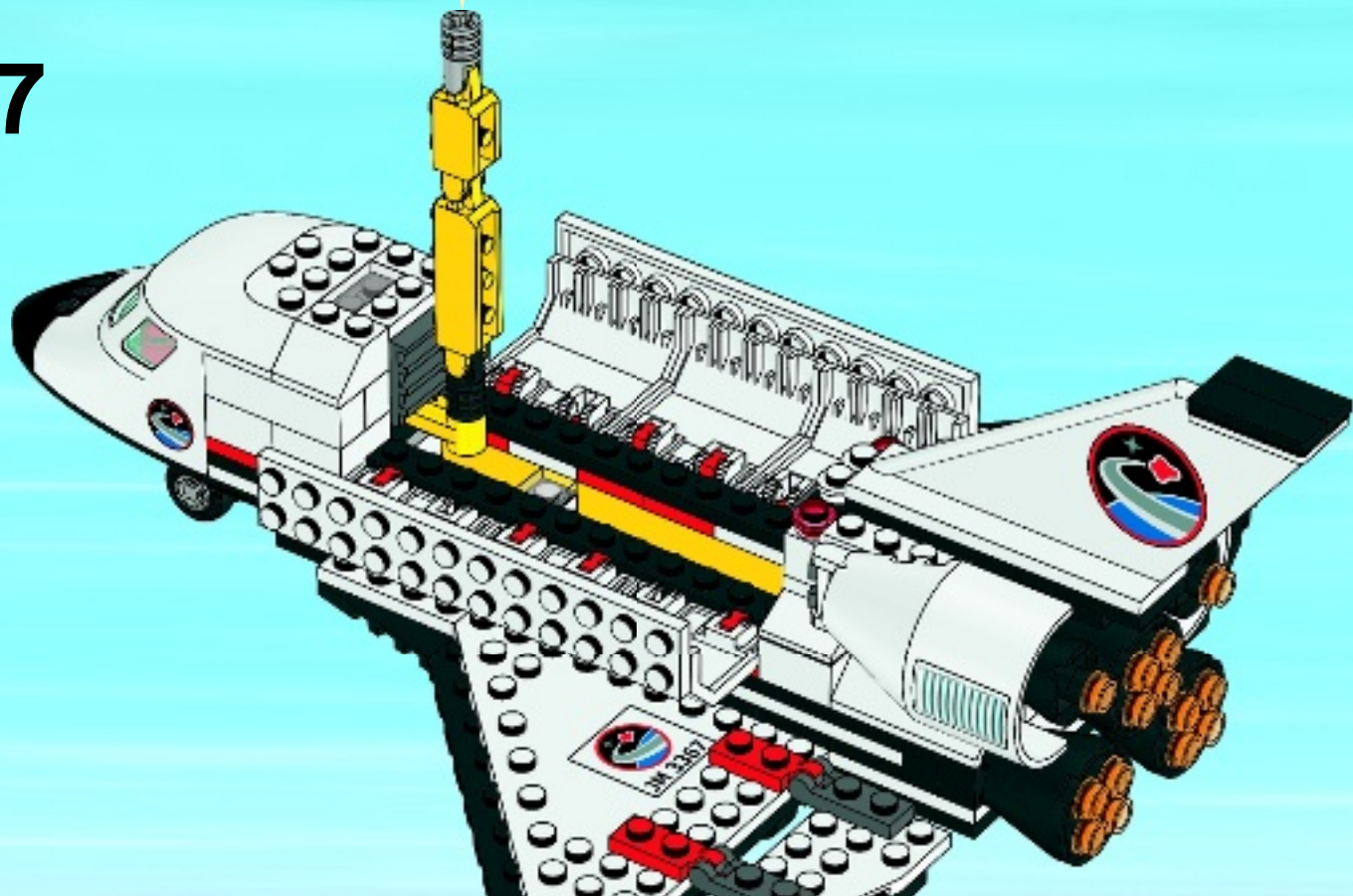

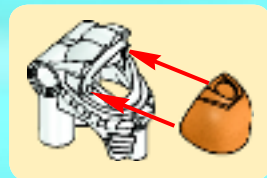
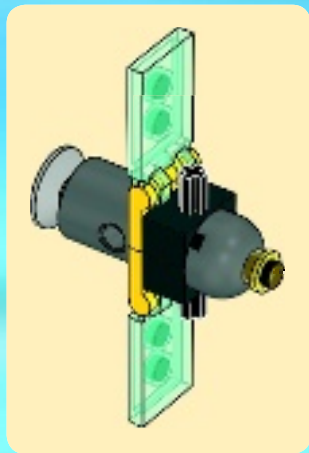

58

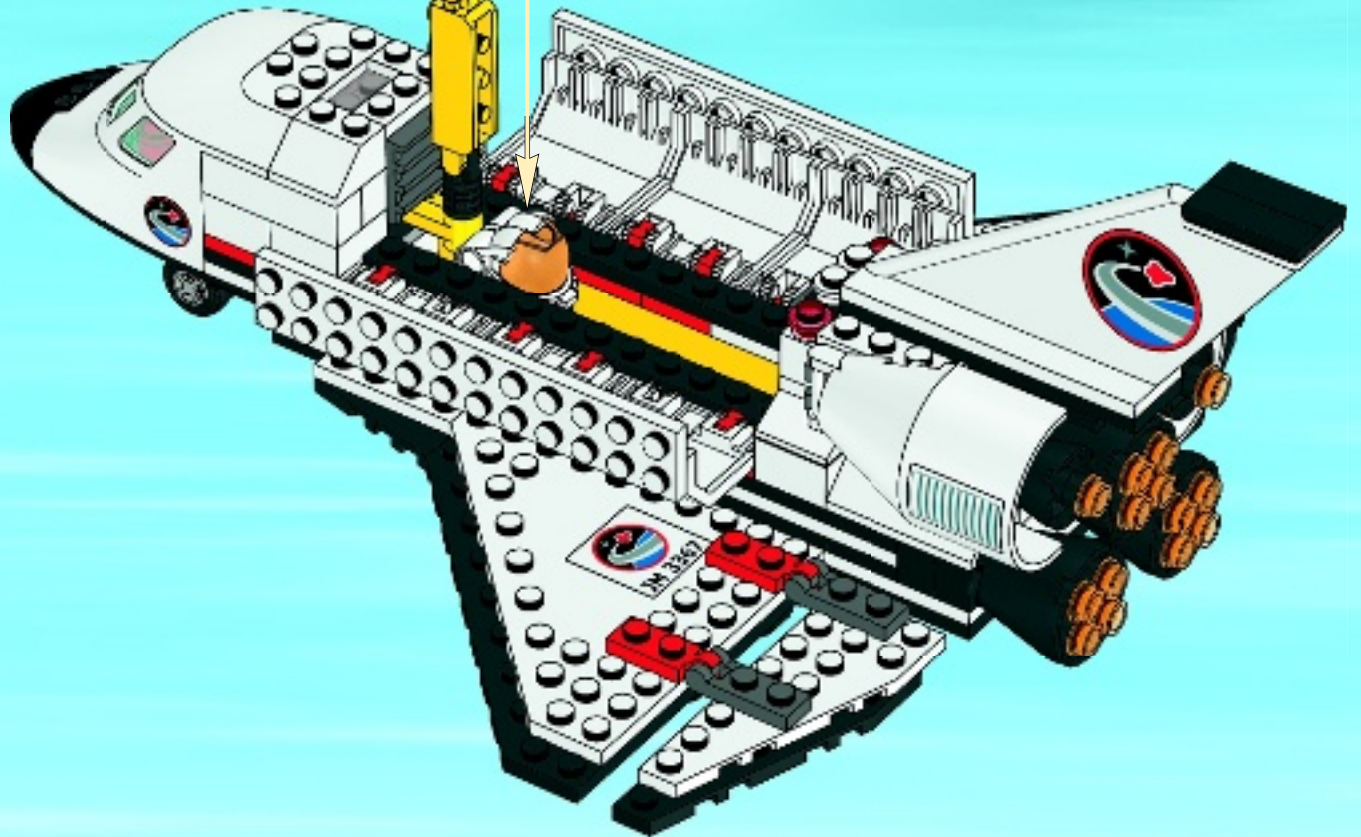



59

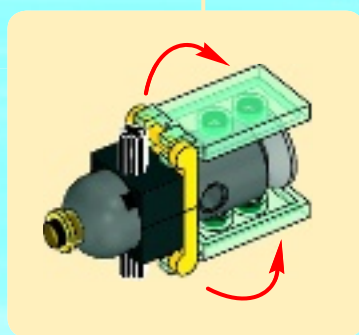
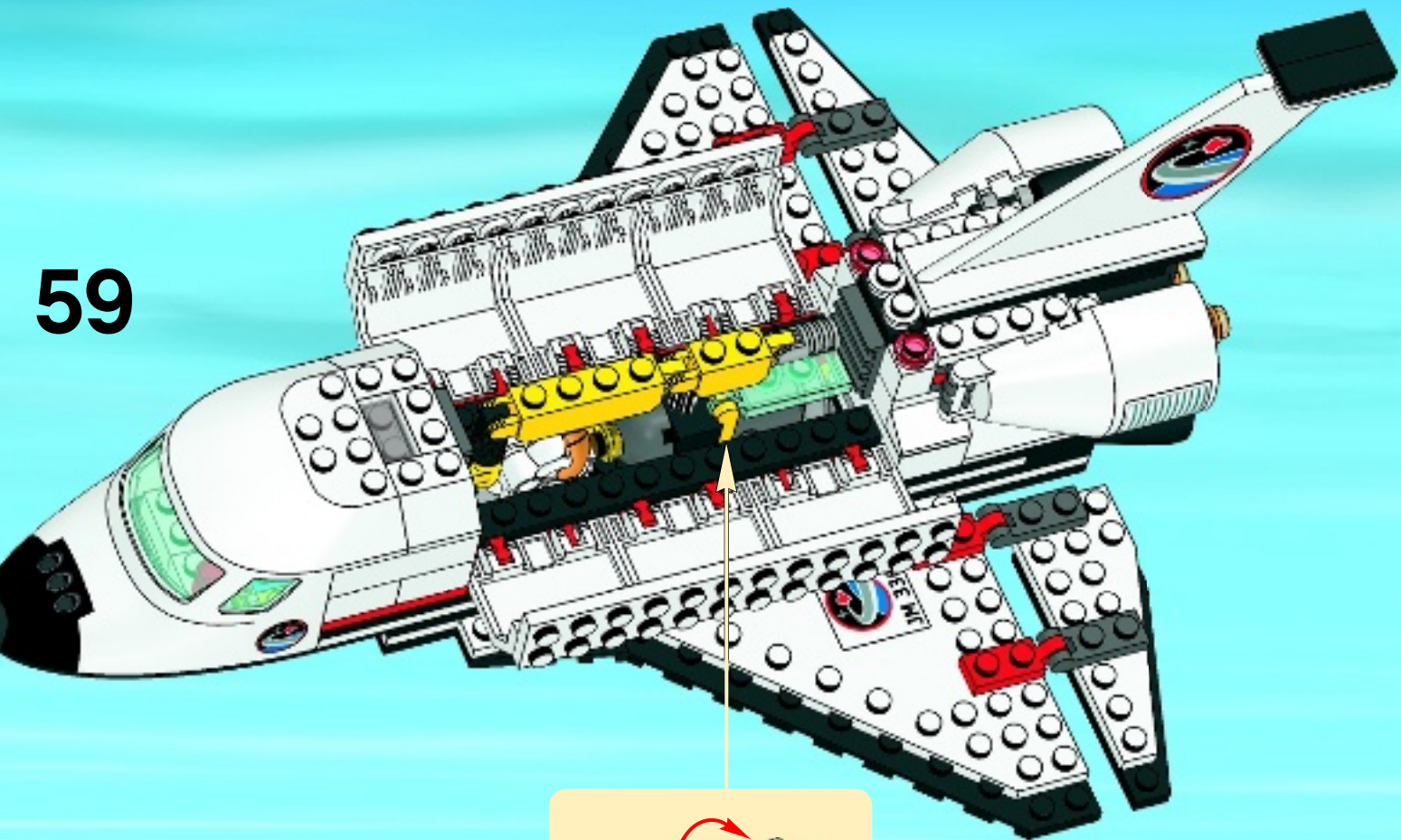



60

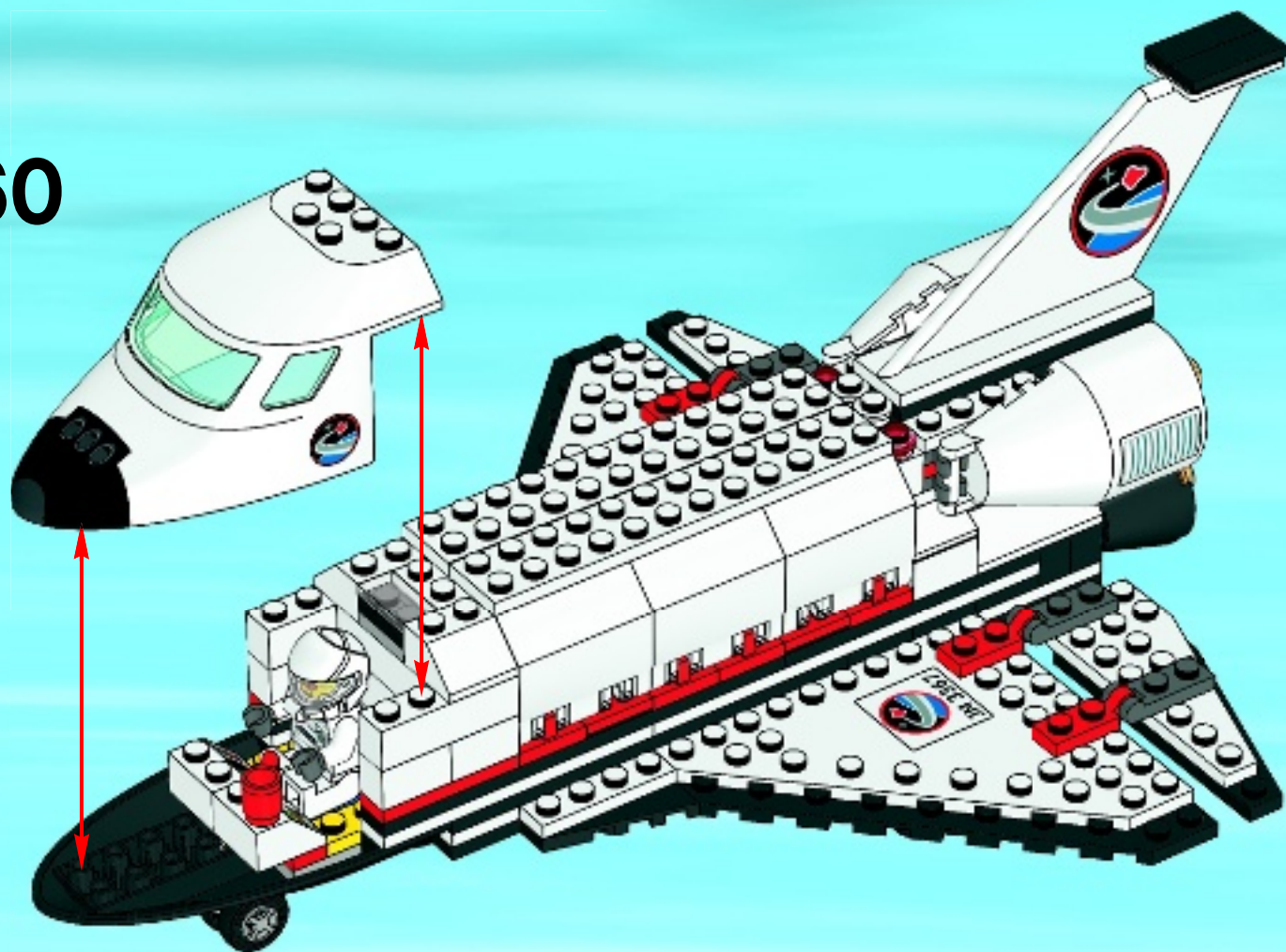

The LEGO CITY logo is located in the top left corner. It features the word "LEGO" in its signature font on a red background, with the word "CITY" in a light blue, sans-serif font to its right.The word "CITY" is part of the logo, positioned to the right of the "LEGO" text.

**An astronaut's Feet can be attached to the end of the Canadian arm to position him or her at a specific location for work in space.**

Les pieds d'un astronaute peuvent être attachés à l'extrémité du Bras Canadien afin de le positionner à l'endroit précis où il doit travailler dans l'espace.

Los astronautas pueden sujetar sus pies al extremo de un brazo mecánico denominado Canadarm para alcanzar una posición específica y llevar a cabo su labor en el espacio.

**NASA Astronaut**



**LEGO**

**CITY**



**438 days was the longest duration for single human space mission.**

La mission spatiale humaine la plus longue en un seul vol a été de 438 jours.

La misión espacial más larga en la que han intervenido seres humanos duró 438 días.

**“Happy Birthday” was the first song to be performed in space.**

« Happy Birthday » a été la première chanson chantée dans l'espace.

La primera canción que se cantó en el espacio fue “Cumpleaños Feliz”.



**NASA Space Shuttle**







**The Space Shuttle's total thrust at liftoff is 7.8 million pound-force.**

La poussée totale de la navette spatiale lors du décollage est de 7,8 millions de livre-force.

Al despegar, una lanzadera espacial desarrolla un empuje total de 34,7 millones de newtons.

**NASA Space Shuttle**





The LEGO CITY logo is located in the top left corner. It consists of the word "LEGO" in its signature yellow font with a black outline, set against a red square background. To the right of this, the word "CITY" is written in a light blue, sans-serif font.The word "CITY" is part of the logo, rendered in a light blue, sans-serif font.

**If someone next to you  
shouted in the vacuum of space you wouldn't be able  
to hear them.**

Si une personne située à côté de vous dans le vide spatial crieait,  
vous ne pourriez pas l'entendre.

Si alguien gritara junto a ti en el vacío del espacio, no podrías oírle.



**A Space Shuttle is used to launch satellites, space telescopes and to fix other spacecraft.**

Une navette spatiale sert à lancer des satellites, des télescopes spatiaux et à réparer les autres vaisseaux spatiaux.

Un transbordador espacial sirve para lanzar satélites y telescopios espaciales, así como para solucionar los problemas de otras naves.



**A School bus can fit in the payload bay of the Space Shuttle.**

Un autobus scolaire peut entrer dans la soute de la navette spatiale.

La bodega de carga de un transbordador espacial podría albergar un autobús escolar.

**NASA Space Shuttle**



**LEGO****CITY**

In collaboration with NASA, En collaboration avec la NASA,  
En colaboración con la NASA.

### NASA Astronaut



**Astronauts are up to 2 inches taller while they are in space. This is due to lack of spinal compression by gravity.**

Les astronautes sont jusqu'à 5 cm plus grands lorsqu'ils sont dans l'espace. Ceci est dû à l'absence de compression de la colonne vertébrale par la gravité.

La altura de los astronautas aumenta hasta 5 centímetros durante su estancia en el espacio. Ello se debe a que la columna vertebral no sufre la compresión que la gravedad causa sobre ella.







CITY



3365



3366



3367



3368



**LEGO** CITY



7279



7285



7286



7287



7288



7498





[www.LEGOclub.com](http://www.LEGOclub.com)



LEGO® Club Email

**LEGO club**™

**FREE! GRATIS! GRATUIT!**



LEGO® Club Magazine

**SIGN UP ONLINE!**

**[www.LEGOclub.com](http://www.LEGOclub.com)**



**00800 5346 5555\***



**1-866-534-6258 • 1-877-518-5346**

US & Canada only

Canada seulement

- \* Freephone. Mobile charges may apply.
- \* Numéro sans frais. Des frais peuvent s'appliquer avec les téléphones cellulaires.
- \* Gebührenfrei. Kosten für Anrufe aus Mobilfunknetzen können abweichen.
- \* Gratis telefonnummer vanaf vaste lijn.
- \* Det er et gratis nummer, når du ringer fra fasttelefon.
- \* Det är gratis, när du ringer från en fast telefon.
- \* Numéro sans frais. Des frais peuvent s'appliquer avec les téléphones portables.



**Customer Service**  
**Kundenservice**  
**Service Consommateurs**  
**Servicio Al Consumidor**

[www.lego.com/service](http://www.lego.com/service) or dial



: 00800 5346 5555  
 : 1-800-422-5346





# WIN!

Go to [www.LEGOsurvey.com/product](http://www.LEGOsurvey.com/product) to fill out a survey for a chance to win a cool LEGO® Product.  
No purchase necessary.  
Open to all residents where not prohibited.

 [www.LEGO.com](http://www.LEGO.com)



## [www.LEGOsurvey.com/product](http://www.LEGOsurvey.com/product)

### GEWINNE! WIN!

Nimm an der Umfrage auf [www.LEGOsurvey.com/product](http://www.LEGOsurvey.com/product) teil und hab die Chance ein cooles LEGO® Produkt zu gewinnen!  
Die Teilnahme am Gewinnspiel führt zu keinerlei Kaufverpflichtungen. Teilnahme in allen nicht ausgeschlossenen Ländern möglich.

Ga naar [www.LEGOsurvey.com/product](http://www.LEGOsurvey.com/product), vul een enquêteformulier in en maak kans op een cool LEGO® product.  
Geen aankoopverplichting, iedereen mag deelnemen, uitzonderend ingezetenden van landen waar een enquêteverbod geldt.

### GAGNE! 当てよう!

Visite [www.LEGOsurvey.com/product](http://www.LEGOsurvey.com/product) pour répondre à un questionnaire et avoir une chance de gagner un produit LEGO® très cool!  
Aucune obligation d'achat.  
Ouvert à tous les résidents des pays autorisés.

[www.LEGOsurvey.com/product](http://www.LEGOsurvey.com/product) にアクセスして、アンケートにご記入ください。当選者にはレゴ®製品を差し上げます。  
お買い上げの必要はありません。  
禁止されていない限り、すべての皆様にご利用いただけます。