

BIONICLE®

www.bionicle.com



8621

TURAGA DUME
& NIVAWK

LEGO

BIONICLE

METRU NUI





1

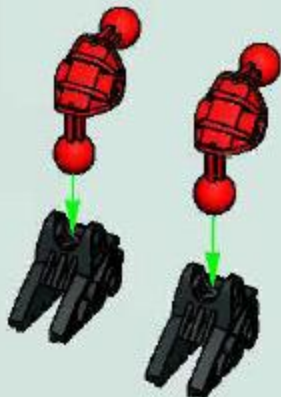

2





3

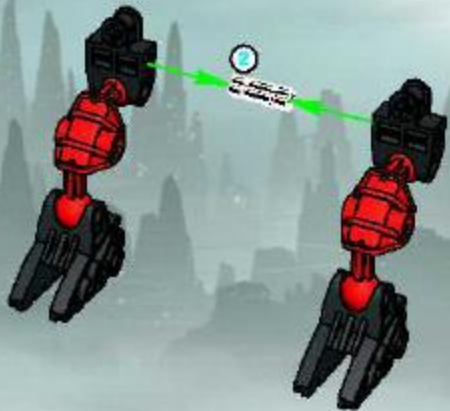

4



5





6

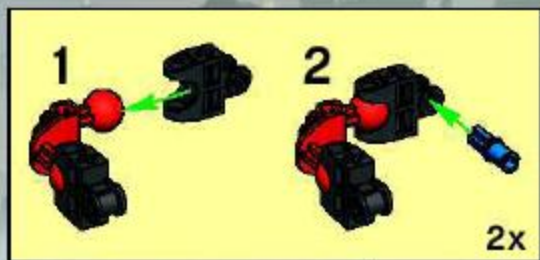

7





8



9



BIONICLE™

2



0925

© 2001

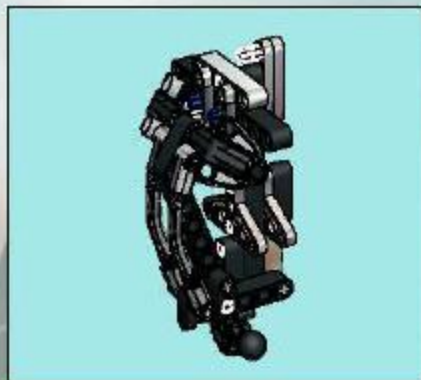
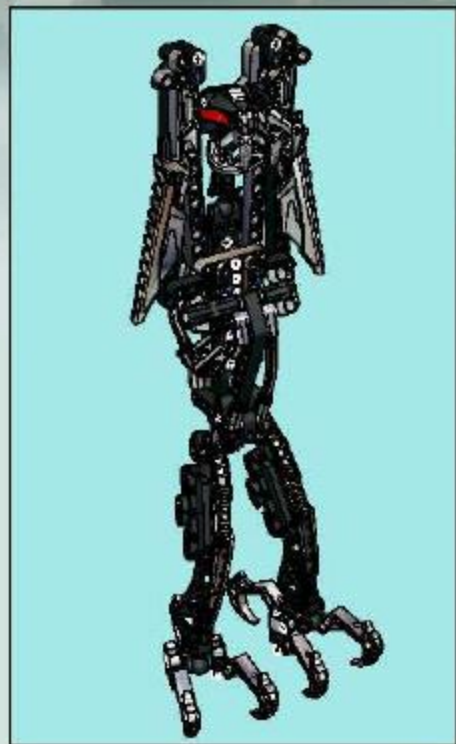

1



2





3



4

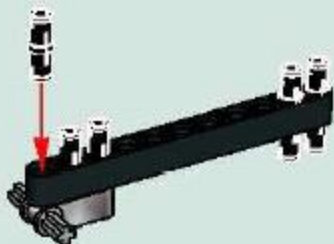

5

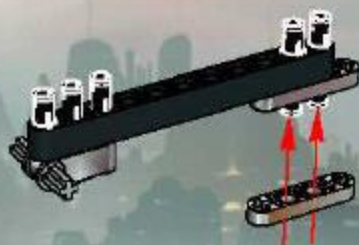

6

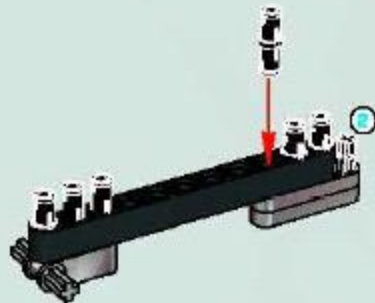



7



8



9

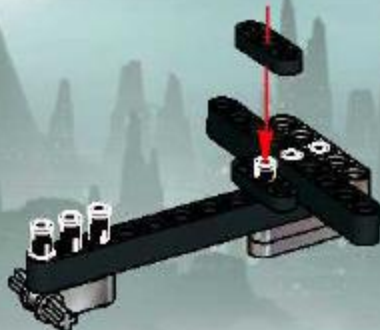



10

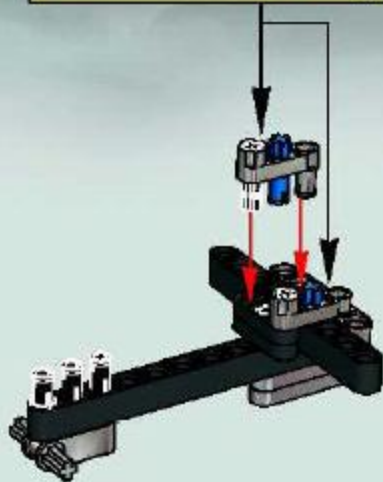
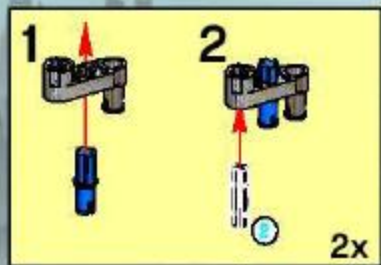

11

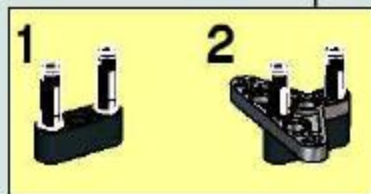
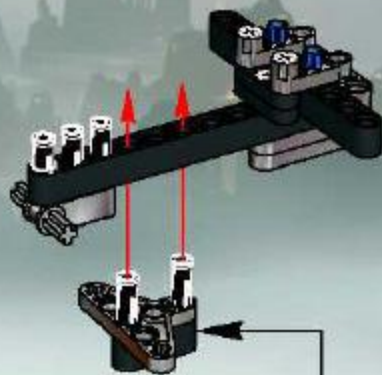

1

2



12

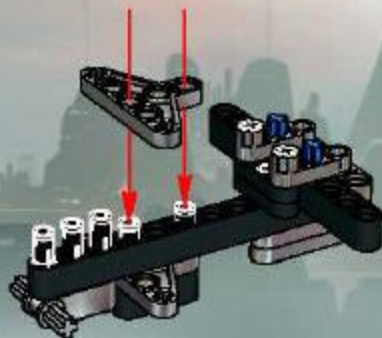

13

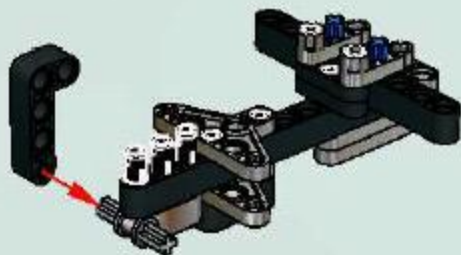

14



15

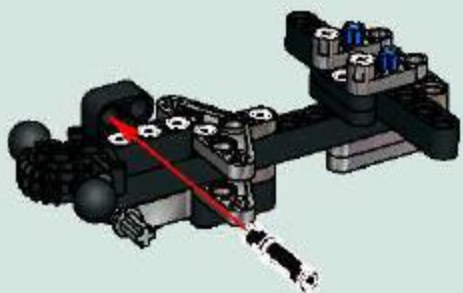



16

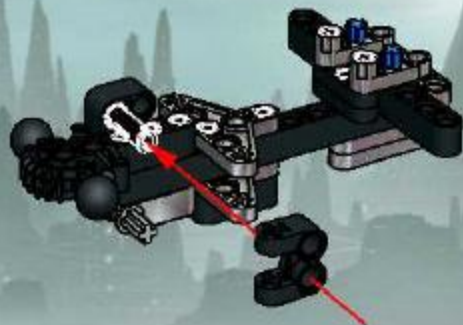

17

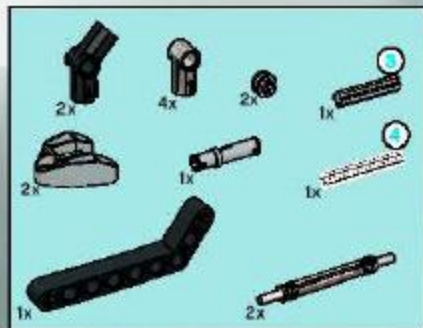
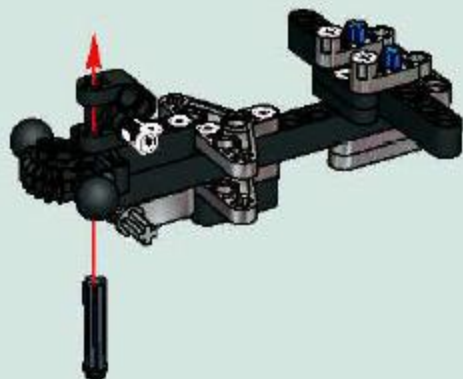

18



3



4



5

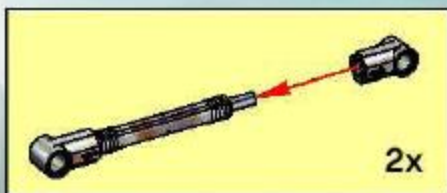

6



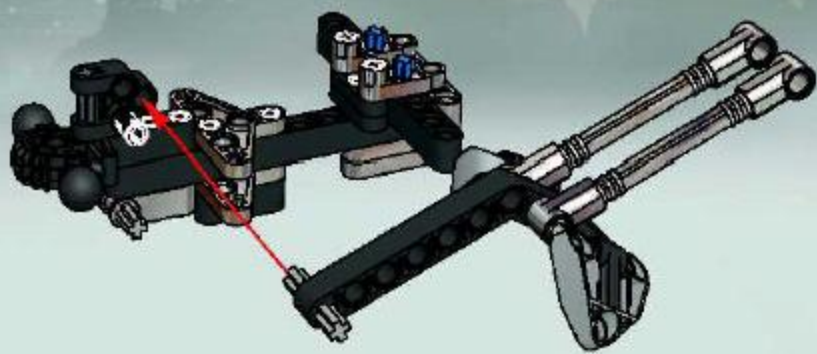



19



20

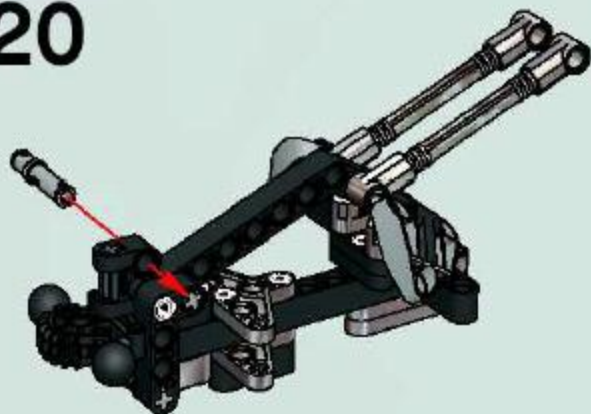

21





1

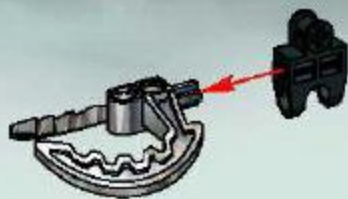

2



3

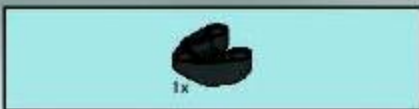

4

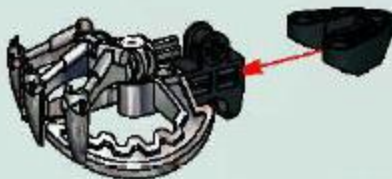



5



6

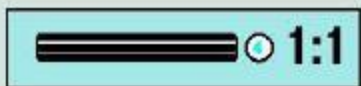

7



8





9



10



22



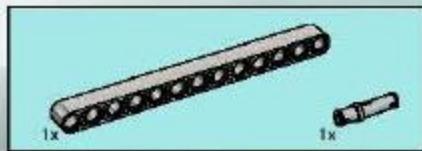
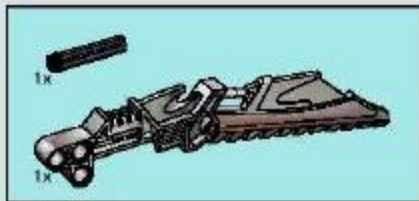
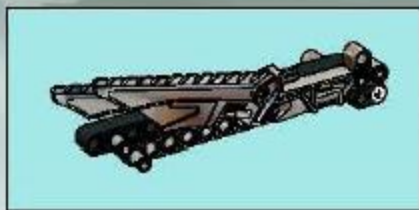

2

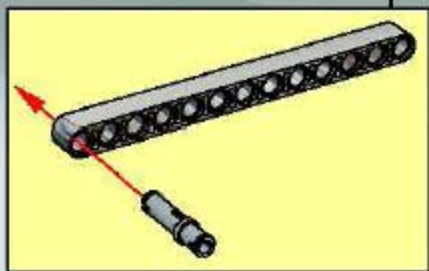



3

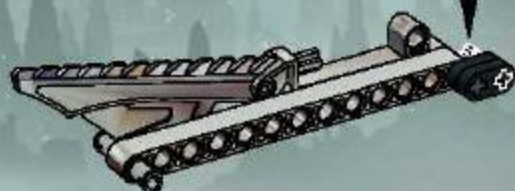

4

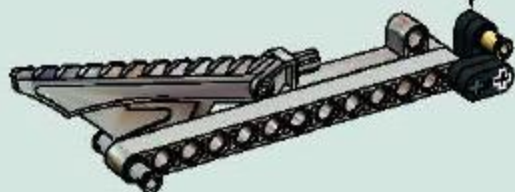
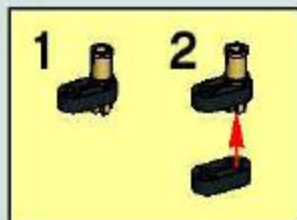

5

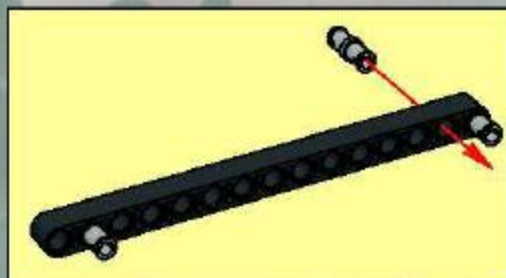

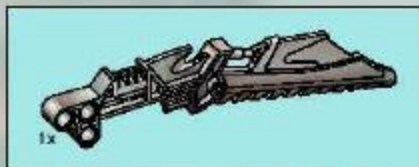

6



7

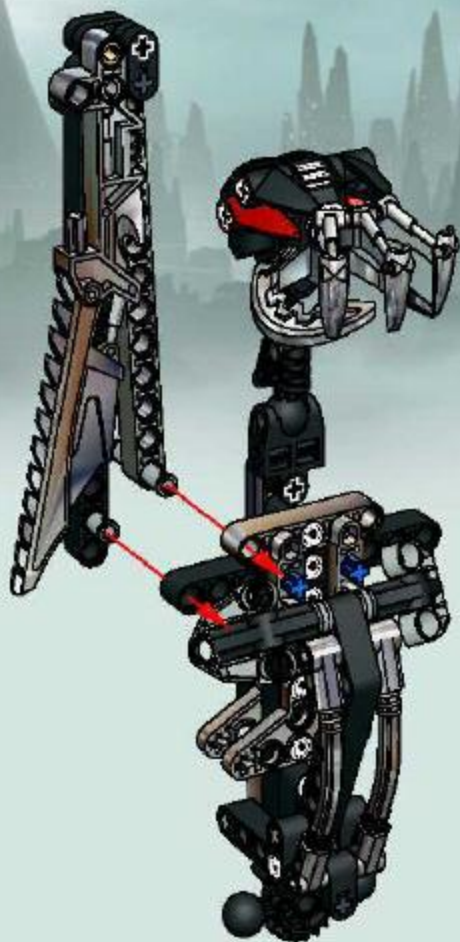

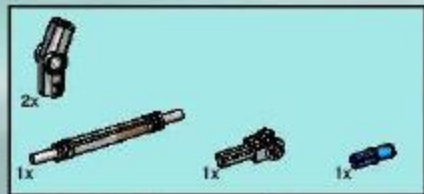

8

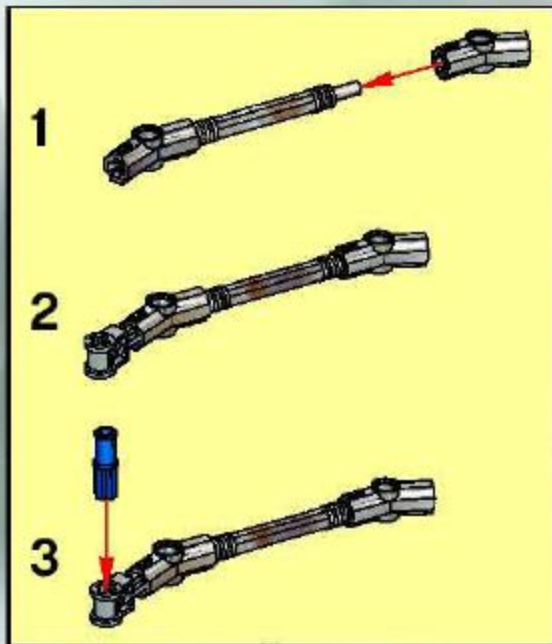
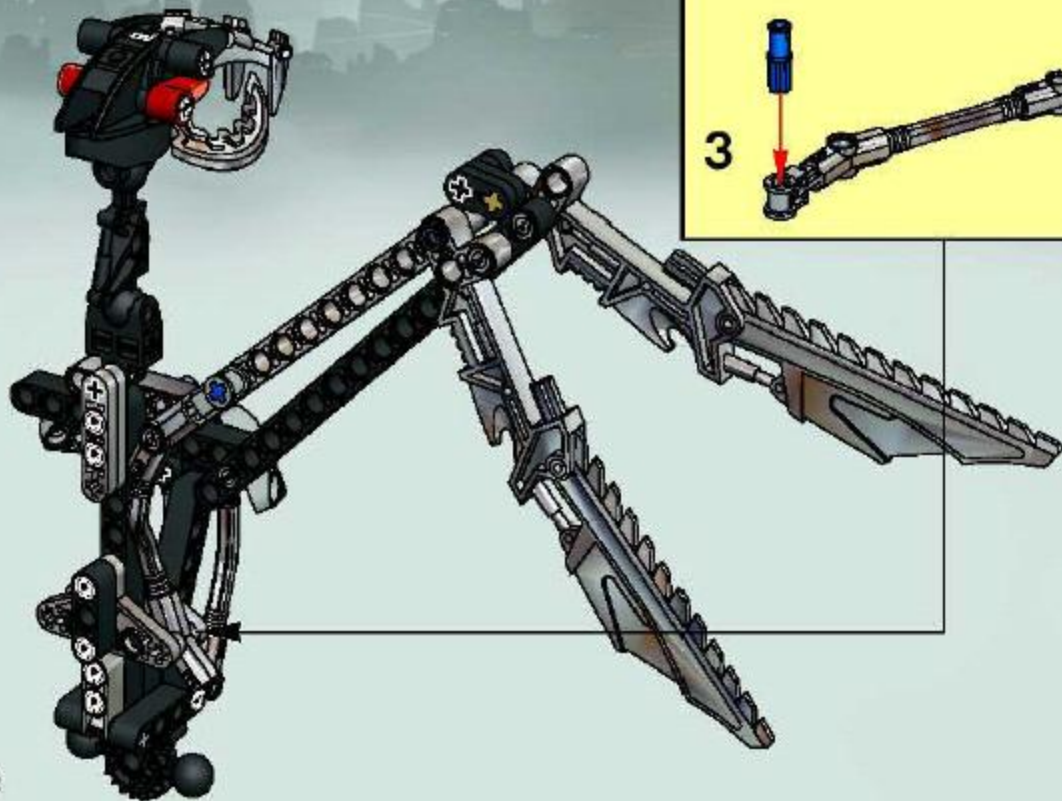



9



10



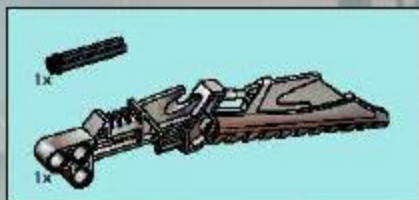

1

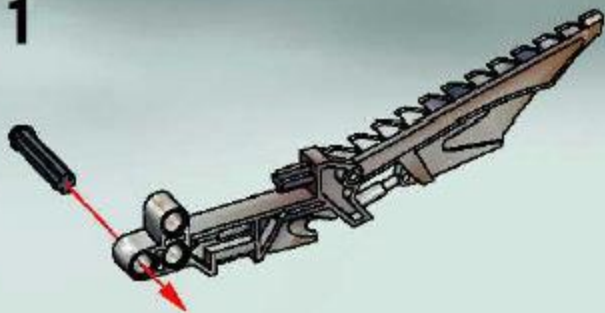

2

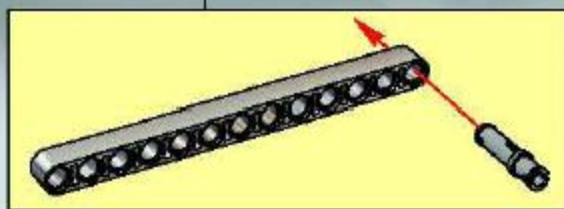
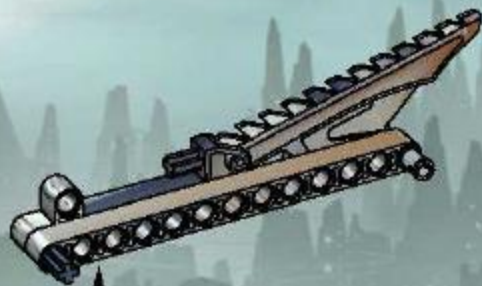



3

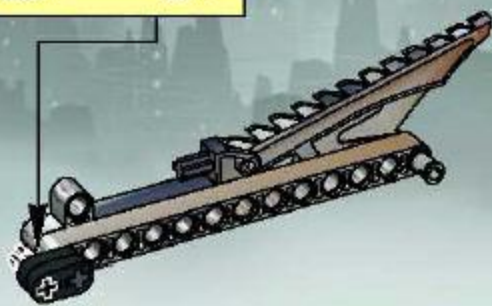

4

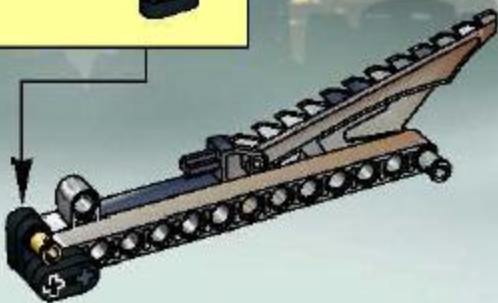
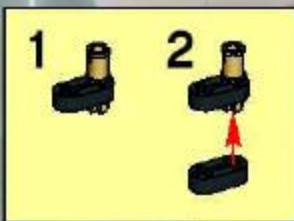



5

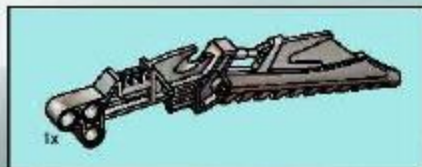
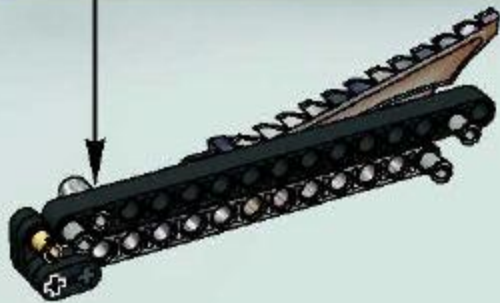
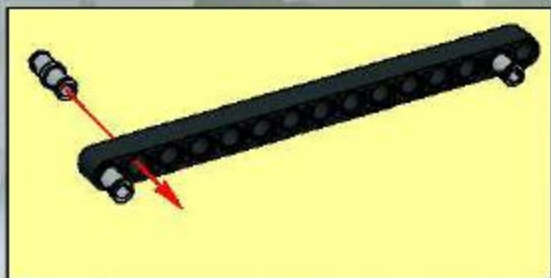

6



16

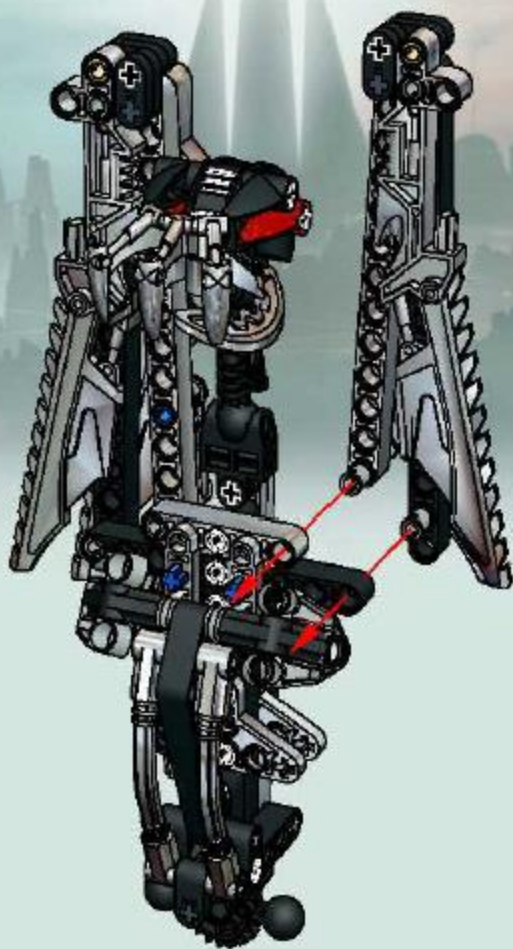

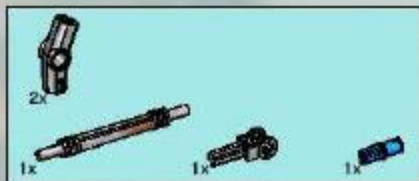

17

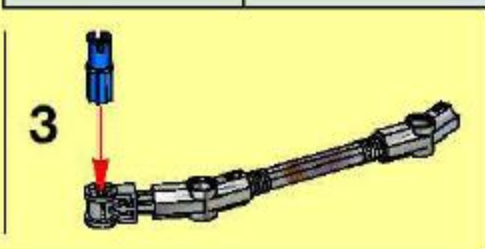
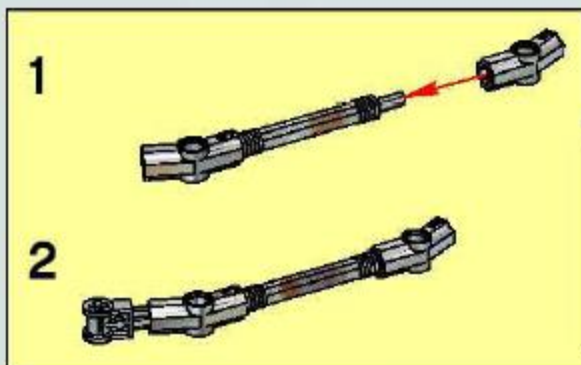
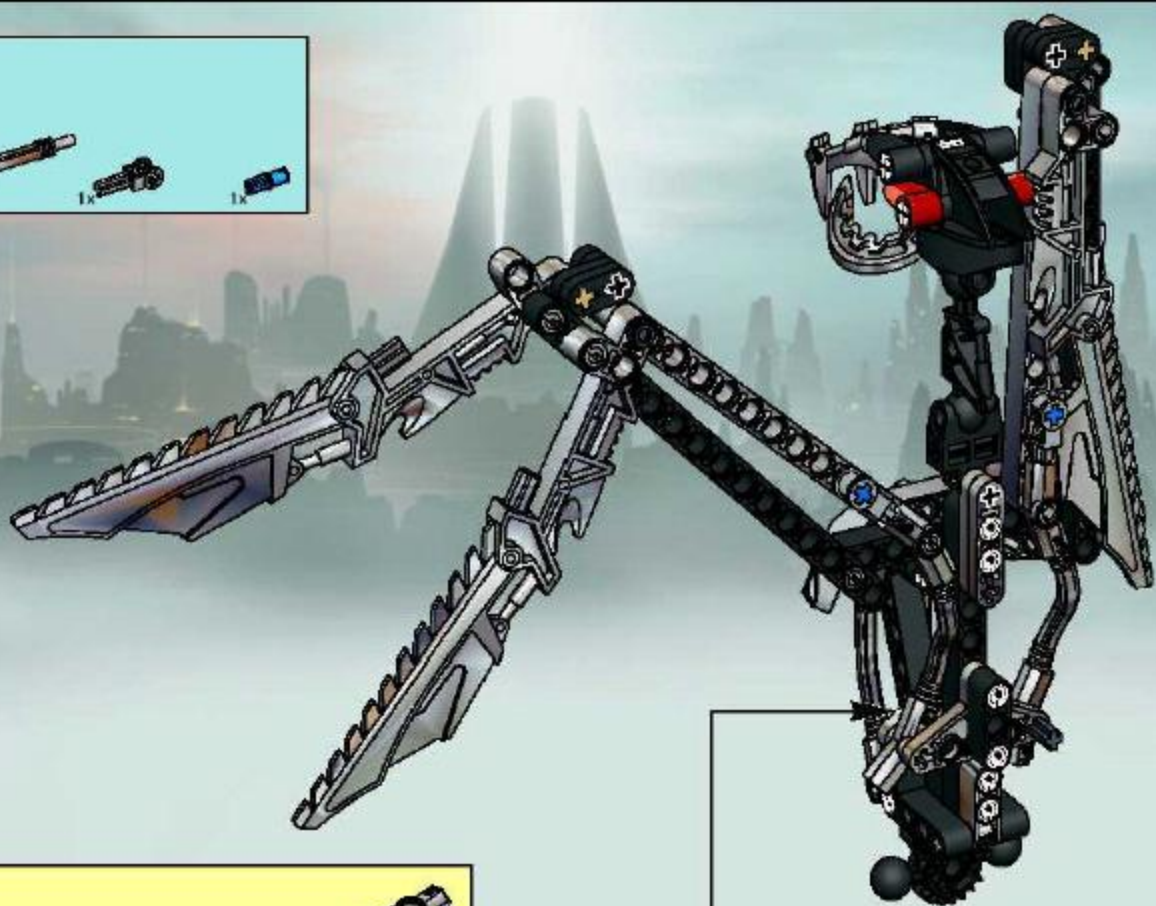



1x

18



19



BIONICLE™

4

9621

© 2001



1x



2x

1



2x

2



2x

3





4



5



6



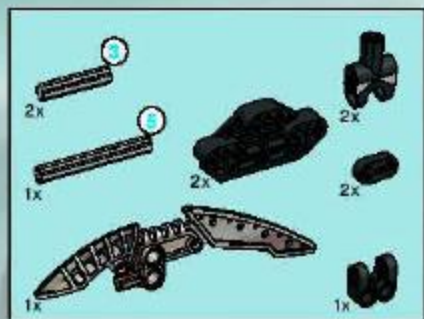

7

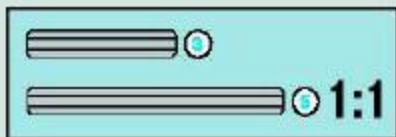

4



5



6



7

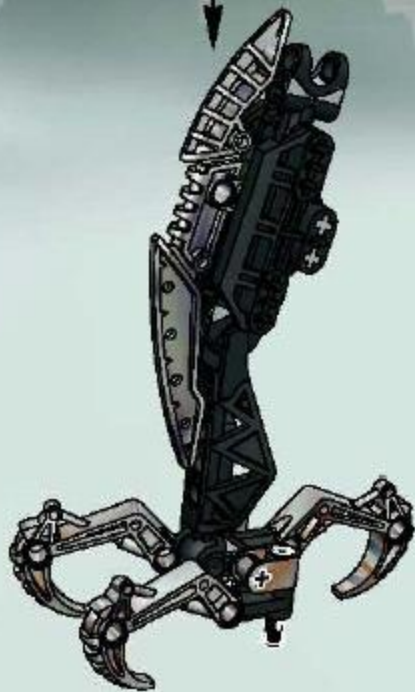

8

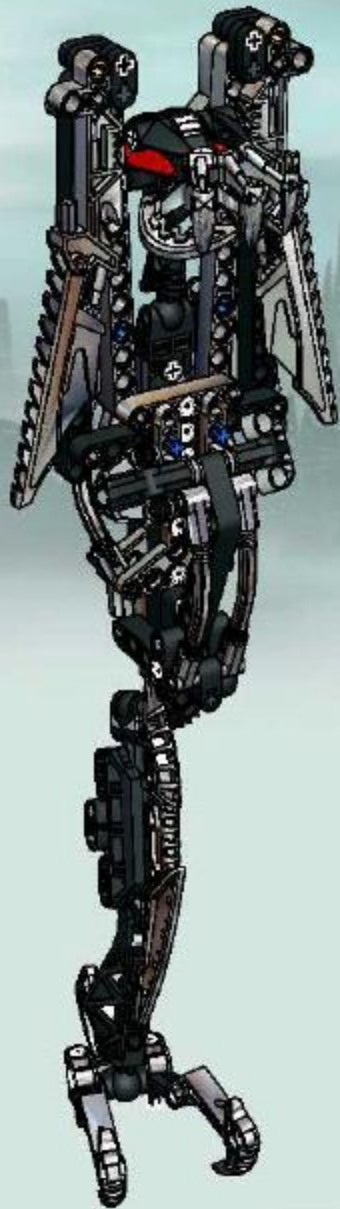



9



10



11

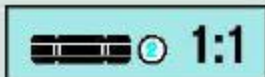



12

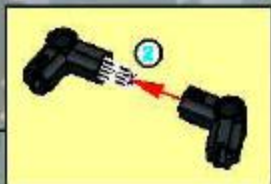

13



14



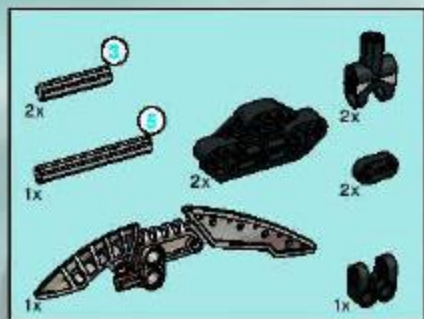

15

1



2



3

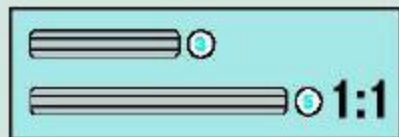

4



5



6



7

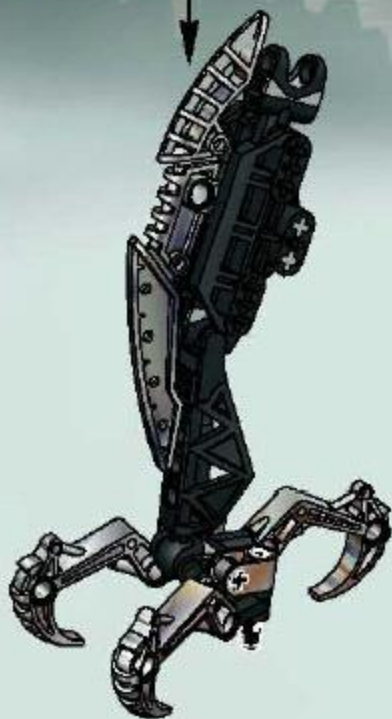

16

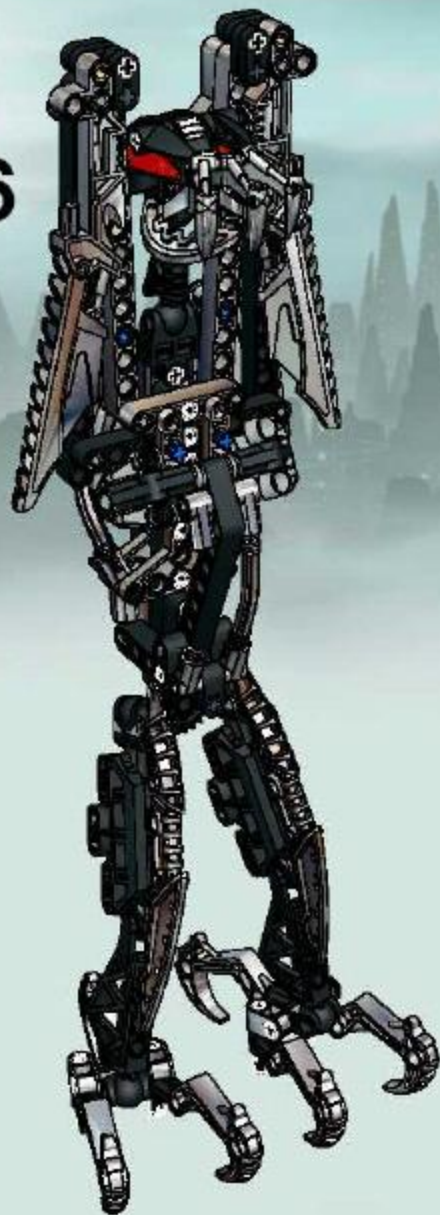

1

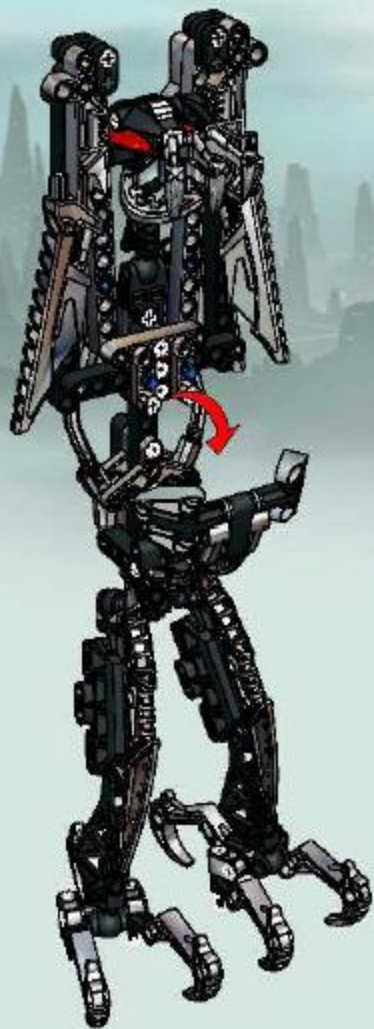

2



3

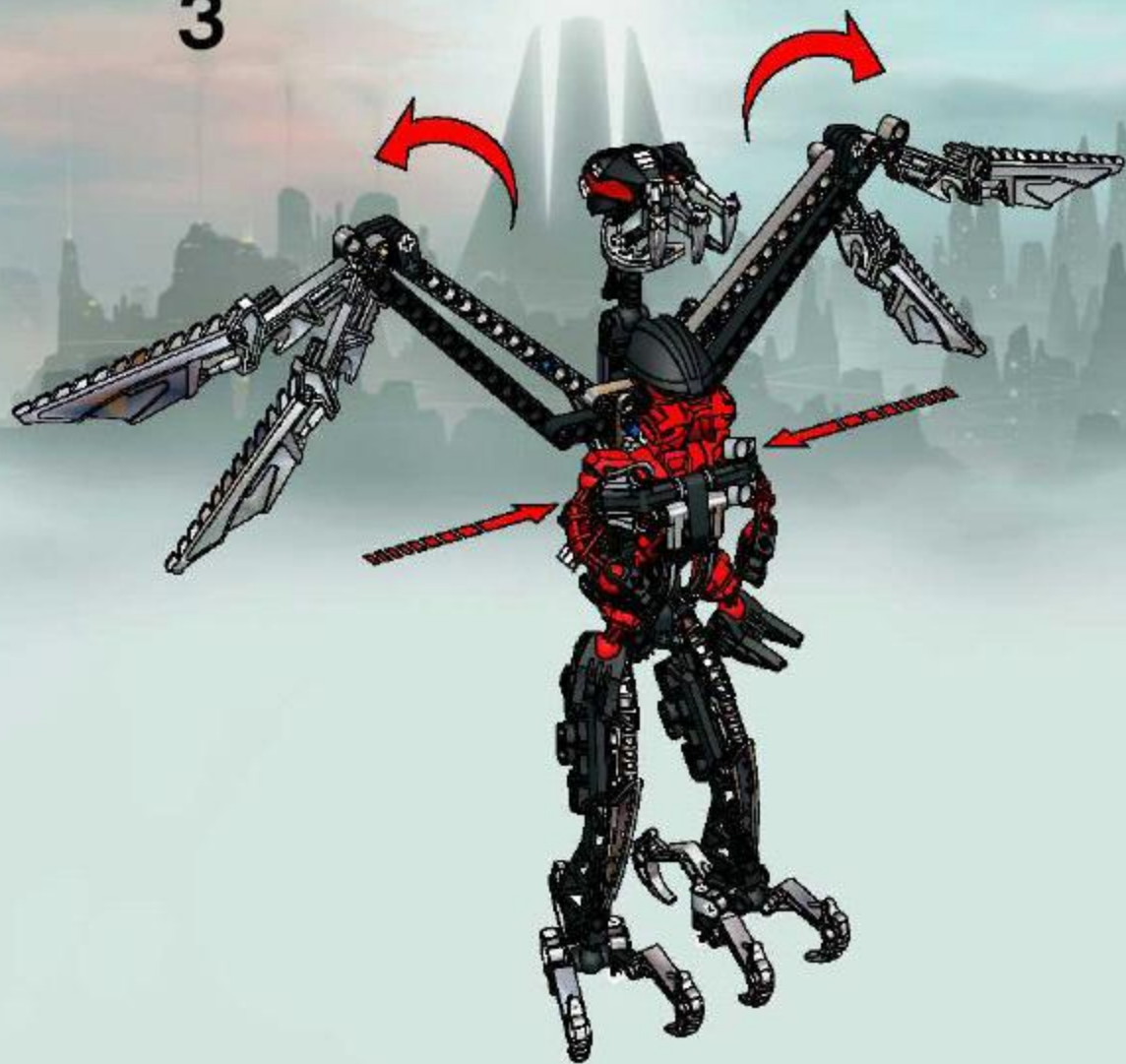



8621



8622



8623

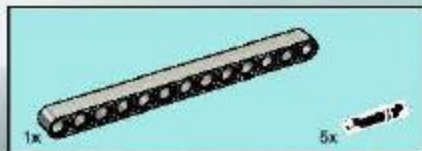
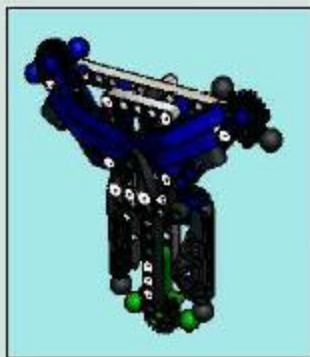

1

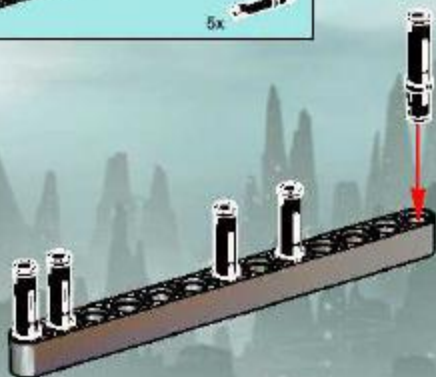

2

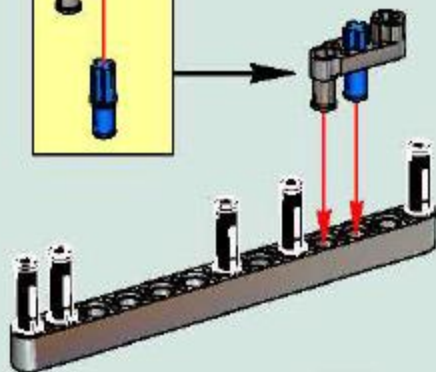
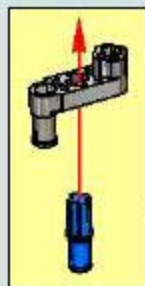

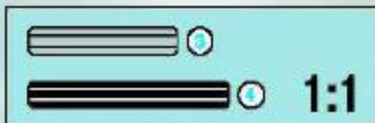
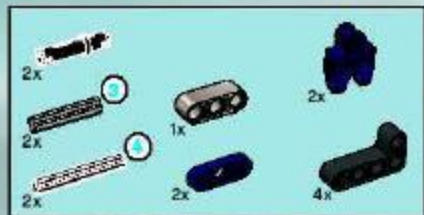

3

1



2



3



4



5

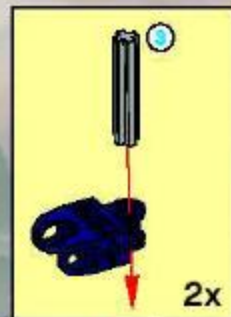

6

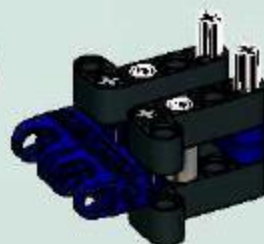

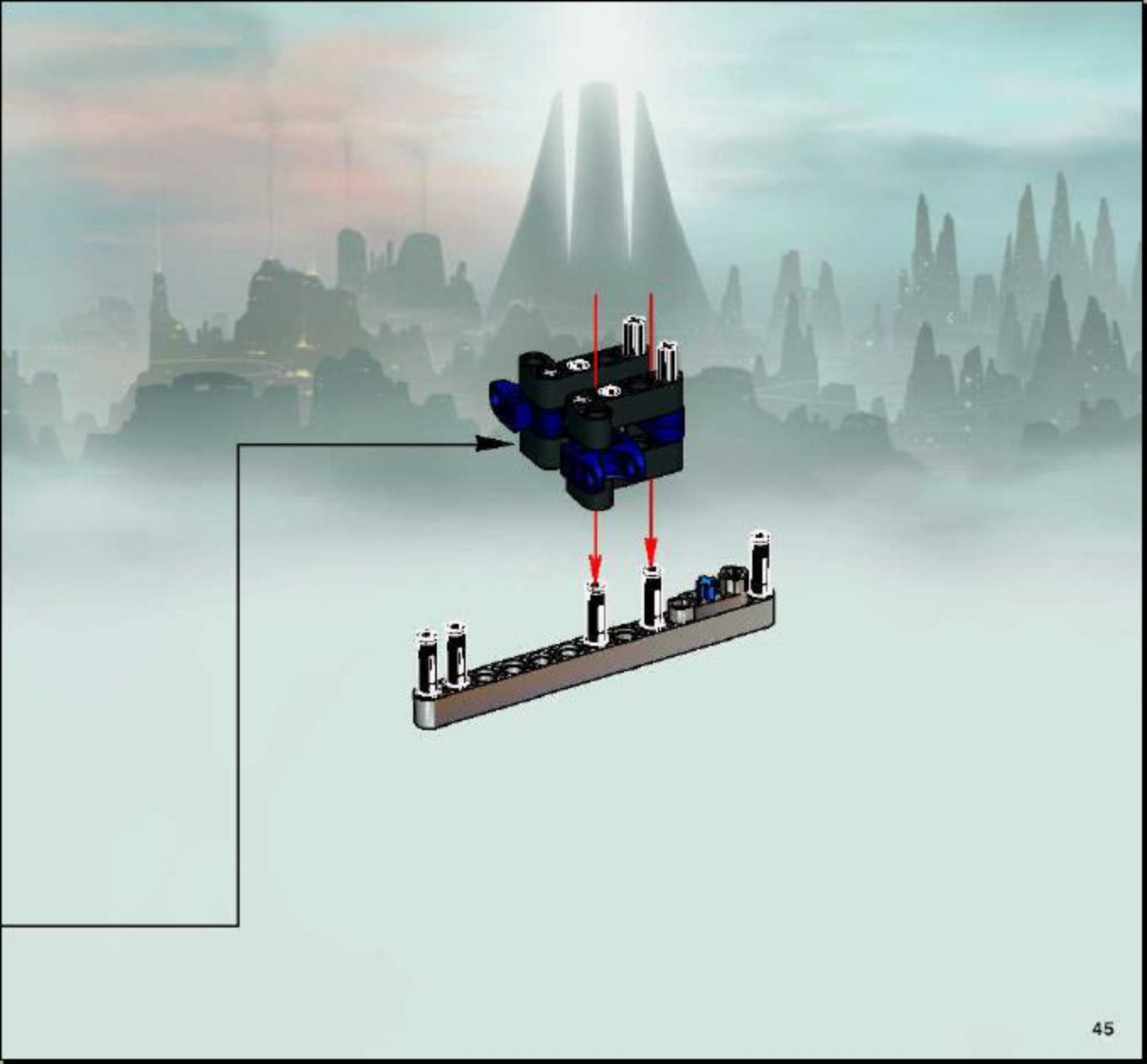

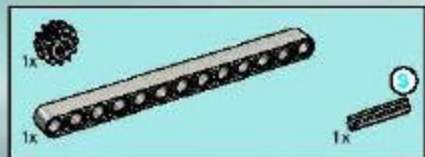

4

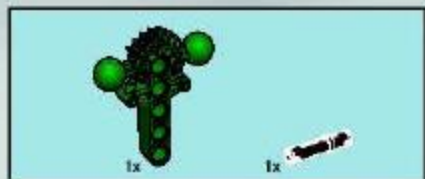
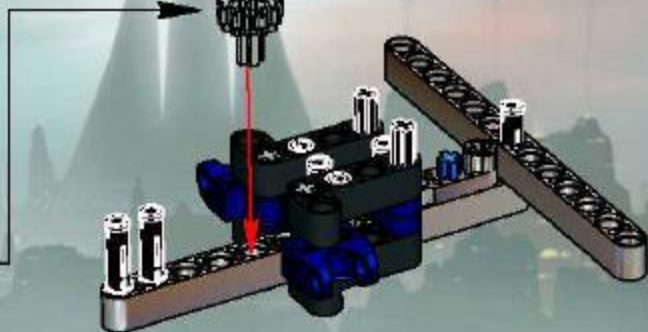
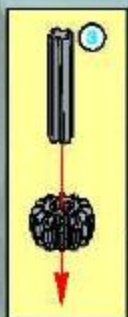

5

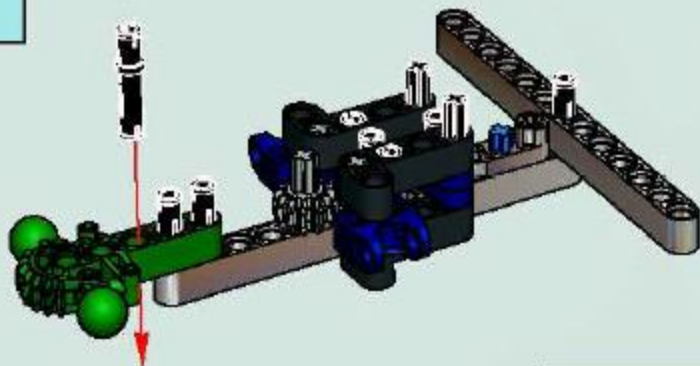



6

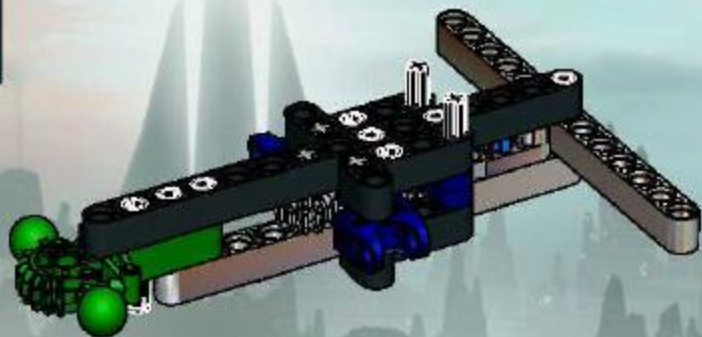

7

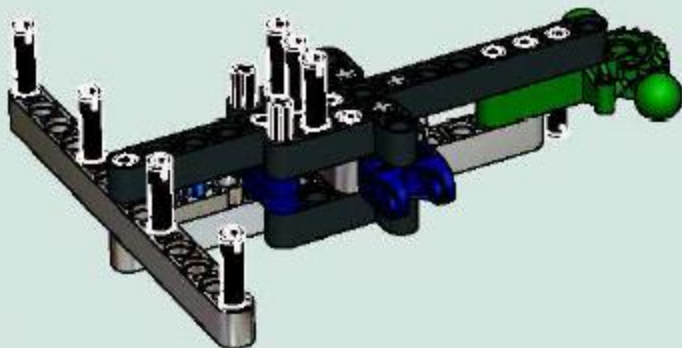

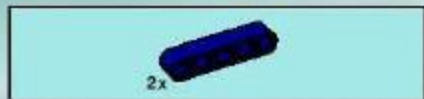

8

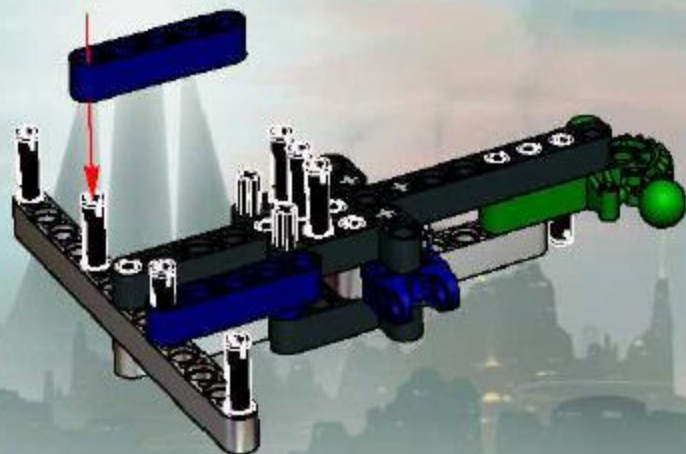

9

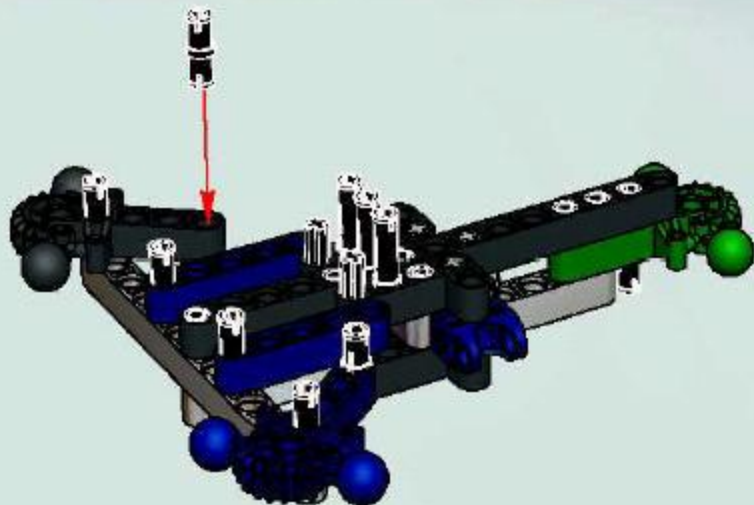



10

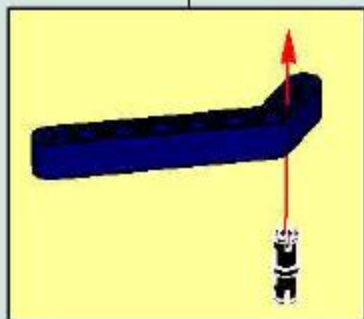
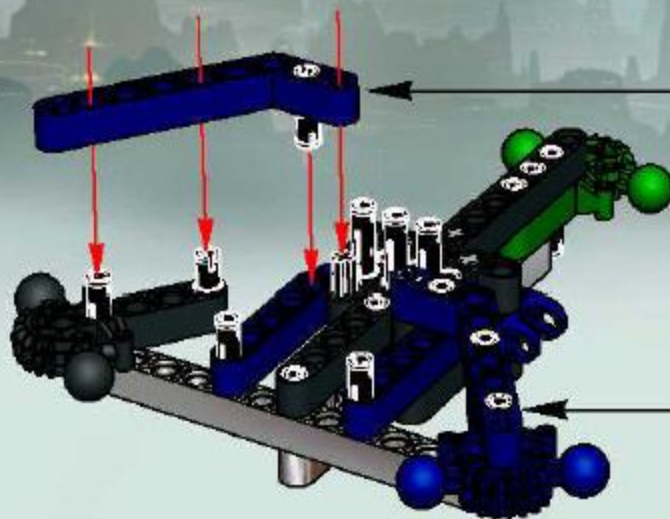
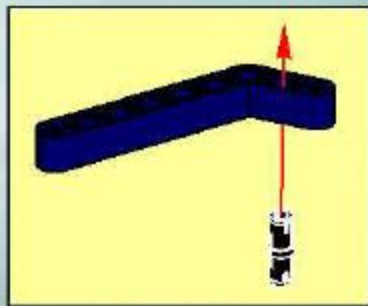



11

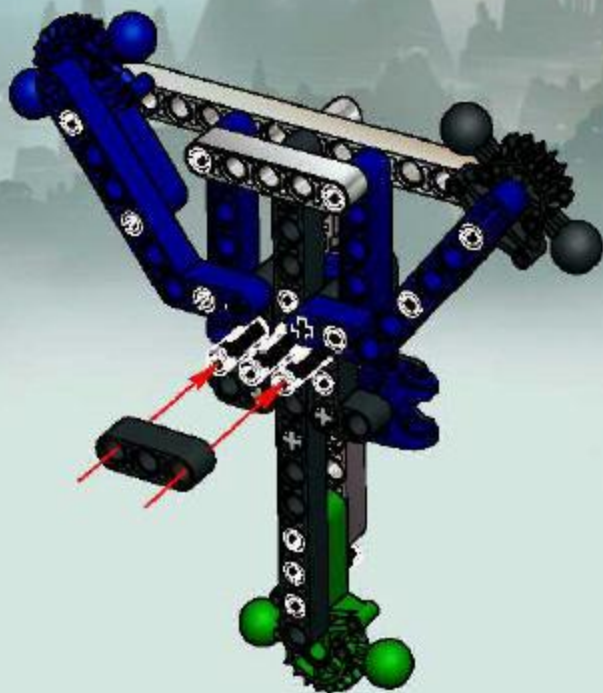

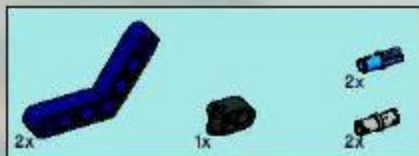

12

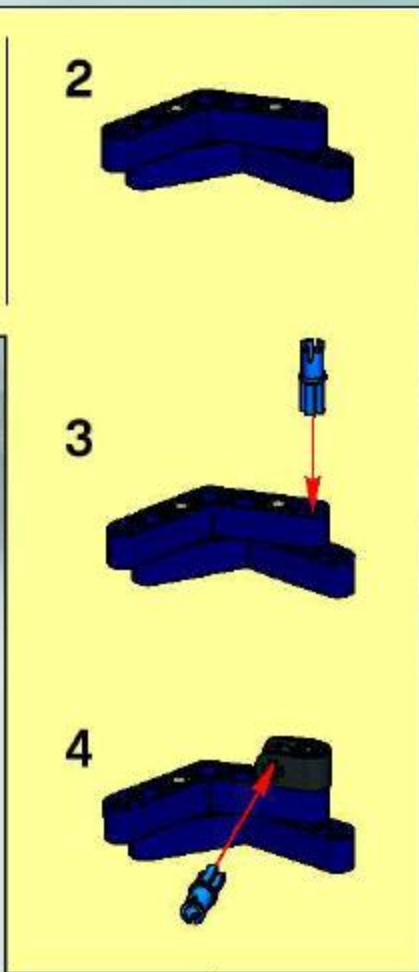
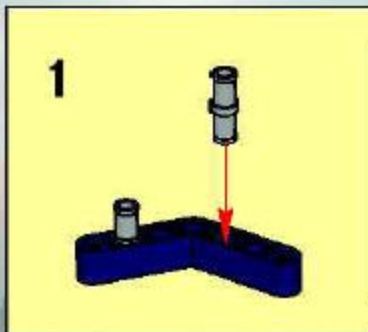
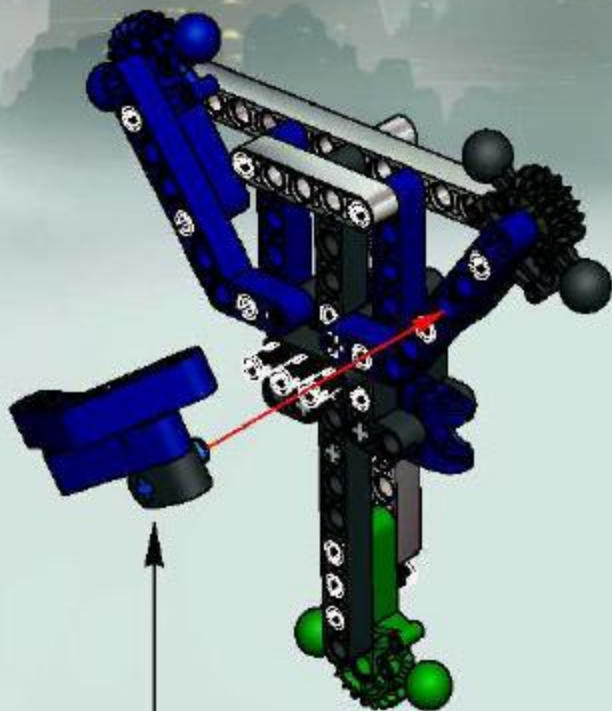



13

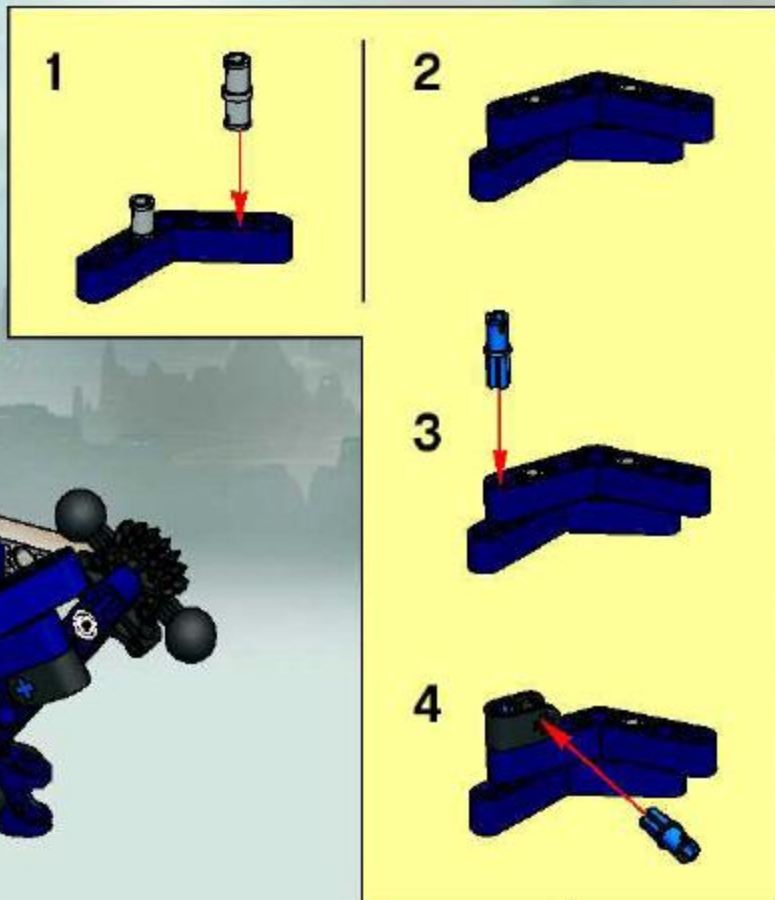
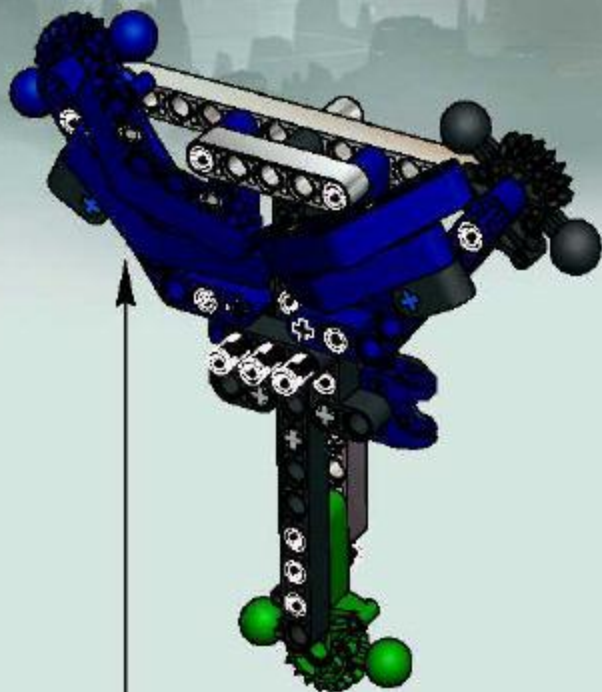



14

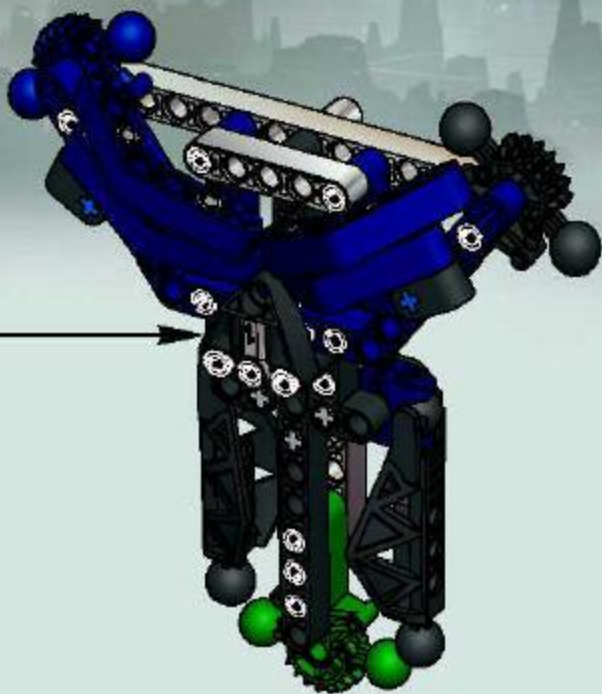

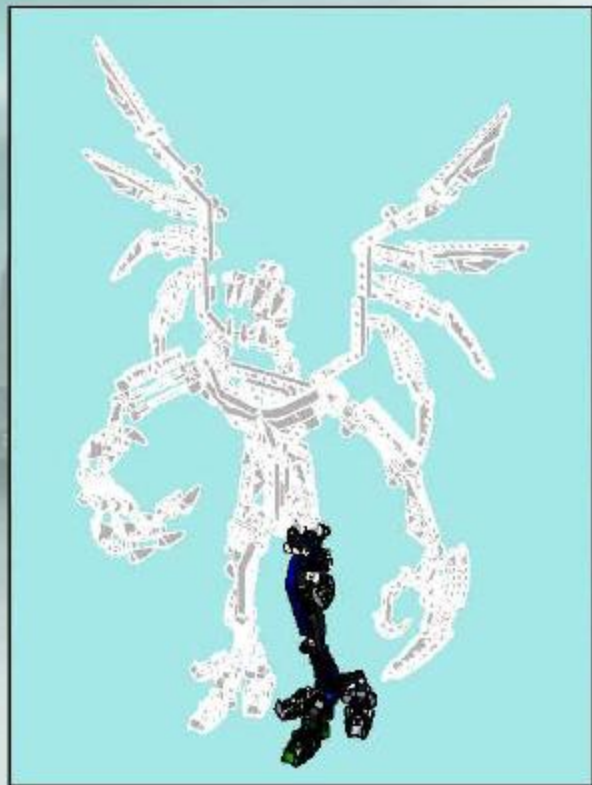

1





2

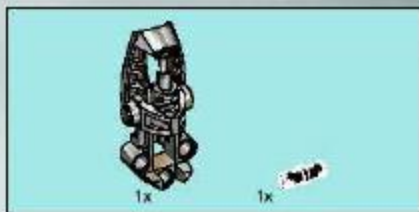

3

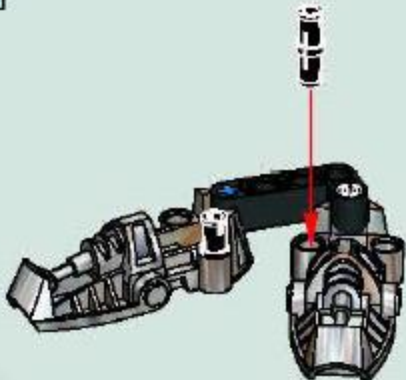

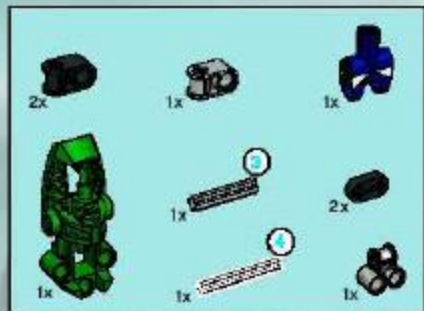

4

1



2

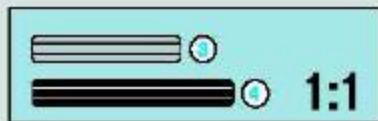

3



4



5



6



7

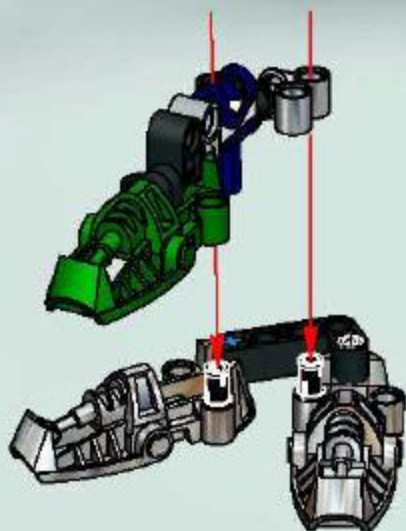

5

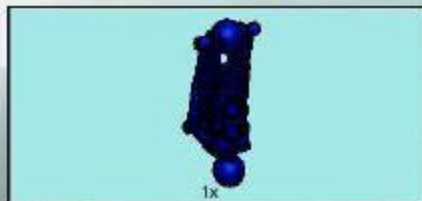



8622
NIDHIKI



8623
KREKKA

BIONICLE

www.bionicle.com



VAHKI
PUURAKH
8614



VAHKI
BORZAKH
8615



VAHKI
VORZAKH
8616



VAHKI
ZORAKH
8617



VAHKI
RORZAKH
8618



VAHKI
KEERAKH
8619



www.bionicle.com



BIONICLE

www.bionicle.com

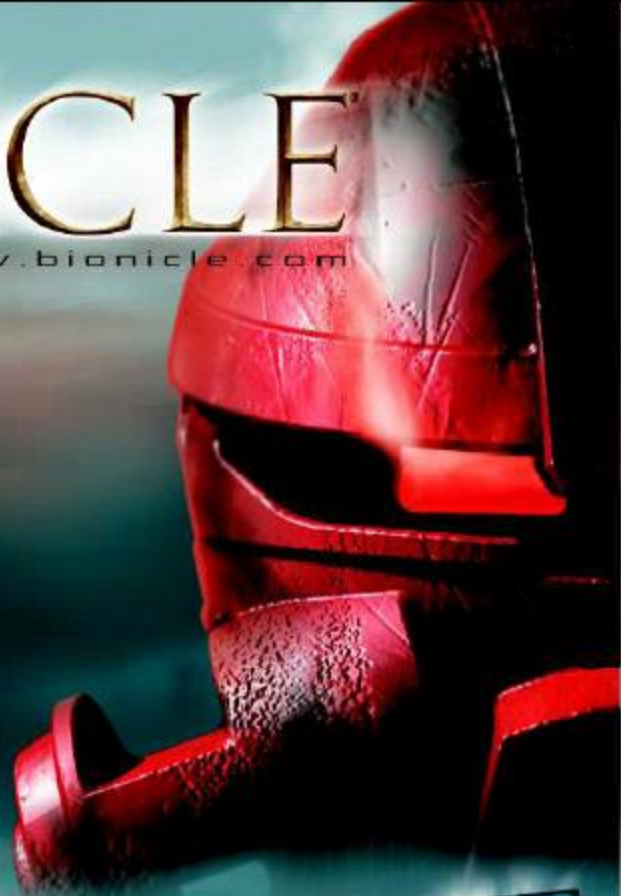



LEGO
LEGOLAND.

WWW.LEGOLAND.COM

LEGO, the LEGO logo, the Brick and Knob configuration and LEGOLAND are trademarks of the LEGO Group. © 2004 The LEGO Group.

Win! Gagne! Gewinne! 当たります



WIN LEGO® PRODUCTS

We would like to know what you think about our new LEGO® product. If you could help us by answering a few questions you are in with a chance of winning an exciting LEGO prize. It will only take you about 3 minutes! Log on to the web address below for further instructions.



Estimada usuario LEGO®

Al contestar algunas preguntas en inglés, francés, alemán o japonés, en el sitio www.acnielsen.aim.dk/lego, podrás participar en el sorteo de algunos valiosos premios LEGO®.



知覚でしつゝ製品が買ひます

私たちの新しい製品について意見を述べた上で、あなたの意見を共有していただくことで、あなたの意見が他のユーザーにも共有され、あなたの意見が製品開発に役立ちます。アンケートに答えるだけで、あなたは当社の製品をよりよく知ることができ、また、いくつかの素晴らしい賞品を当選するチャンスがあります。



GAGNE DES PRODUITS LEGO®

Nous aimerions savoir ce que tu penses de ton nouveau produit LEGO®. Si tu veux bien nous aider en répondant à quelques questions, tu recevras peut-être bientôt un fantastique prix LEGO. Et cela ne te prendra que 3 minutes environ ! Tu obtiendras davantage d'informations en visitant le site Internet indiqué ci-dessous.



Care Consumidor de LEGO®

Ao responder a algumas perguntas em inglês, francês, alemão ou japonês no endereço www.acnielsen.aim.dk/lego irá participar num concurso para ganhar valiosos prémios de LEGO®.



GEWINNE LEGO® PRODUKTE

Wir sind sehr an deiner Meinung über dein neues LEGO® Produkt interessiert. Wenn du uns den Gefallen tust und ein paar Fragen beantwortest, kannst du einen tollen LEGO Preis gewinnen. Das Ganze dauert nur etwa 3 Minuten! Gehe einfach zu der unten angegebenen Webadresse - dort findest du weitere Informationen.



Kérdés új LEGO® Vásárló

Ha ellátogat az www.acnielsen.aim.dk/lego honlapra és ott angol, francia, német vagy japán nyelven megválaszol néhány kérdést, akkor részt vehetsz egy versenyben, amelyben értékes LEGO® ajándék nyerhetsz.

www.acnielsen.aim.dk/LEGO





www.bionicle.com

