

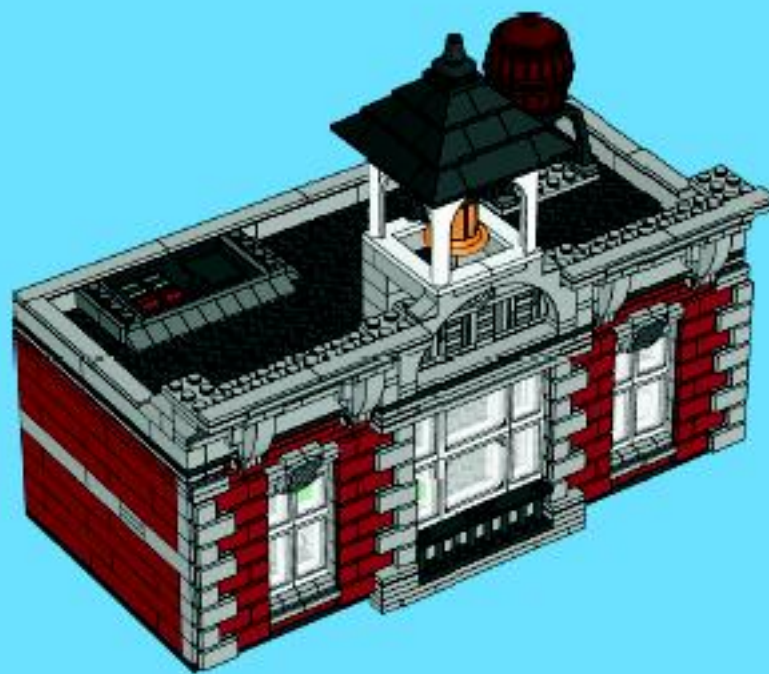

FIRE BRIGADE
LA BRIGADE DE FEU

10197

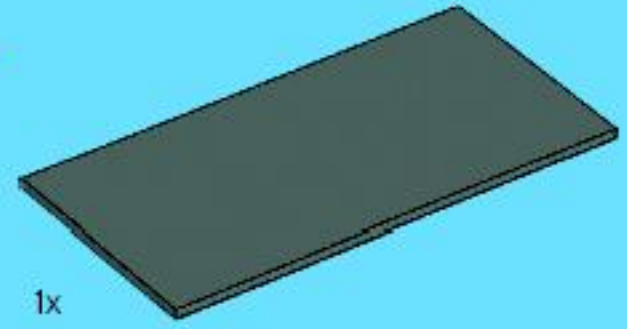

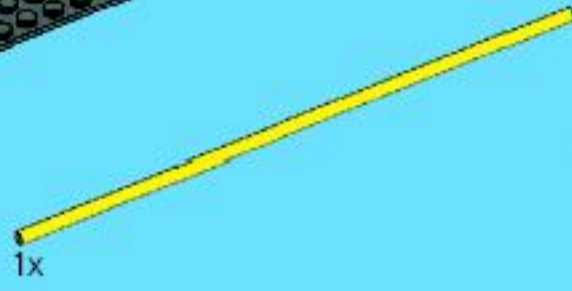
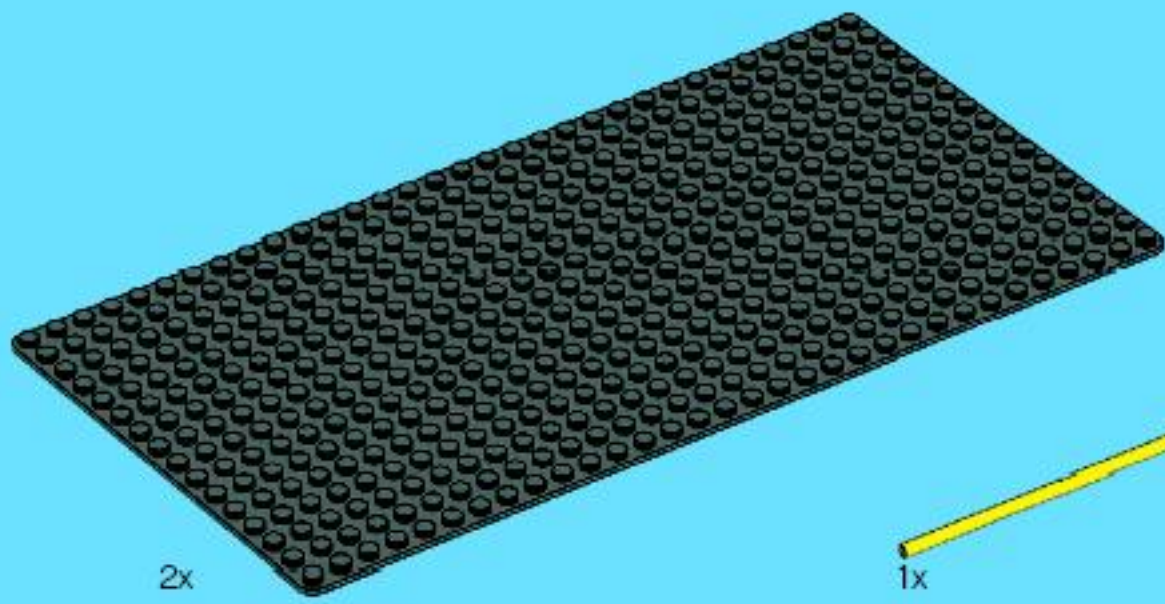

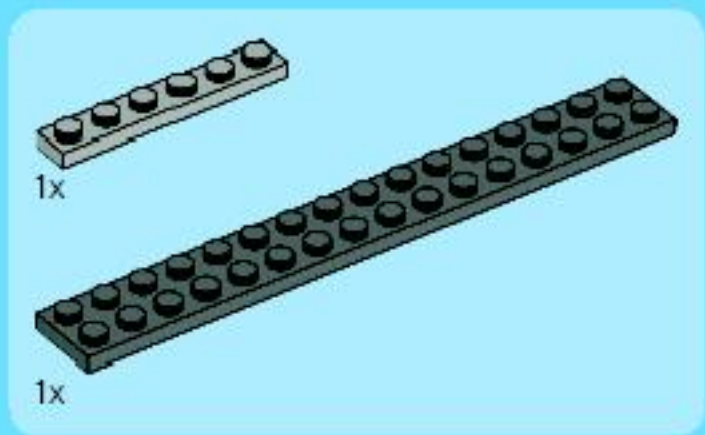
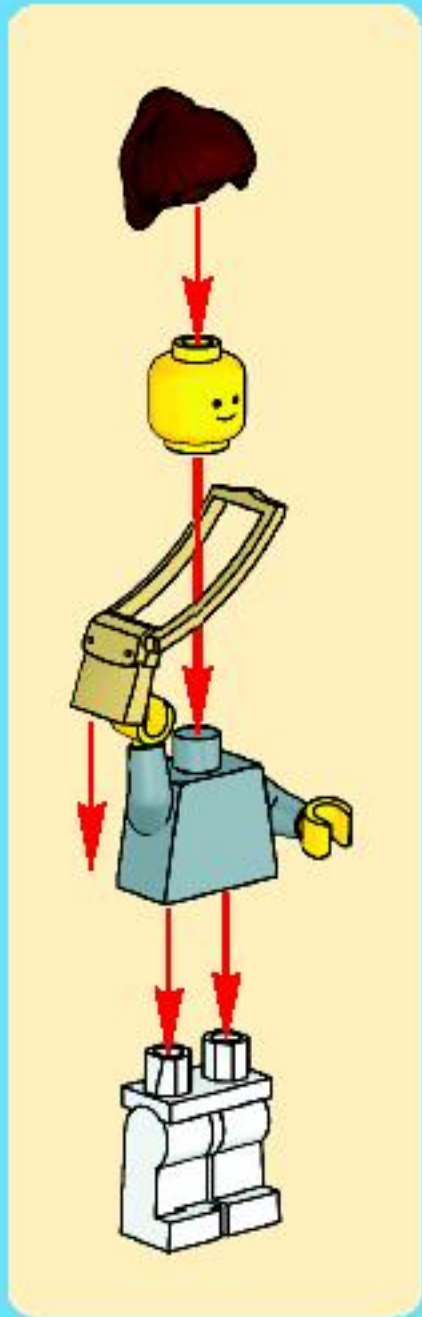

1

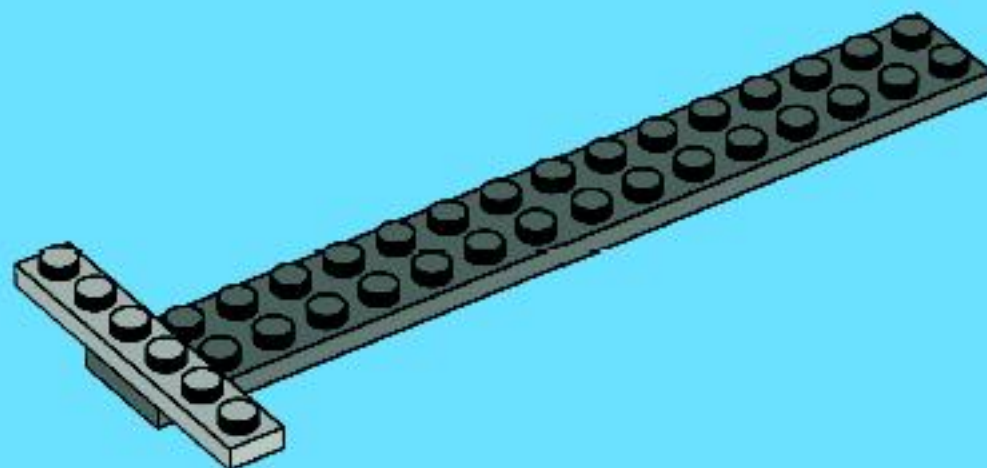

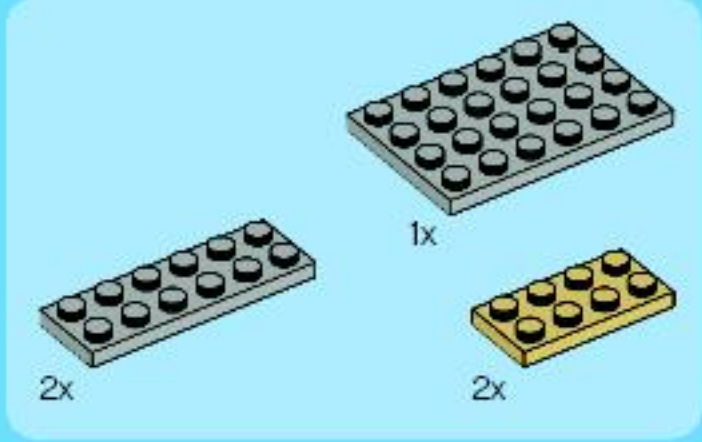

2

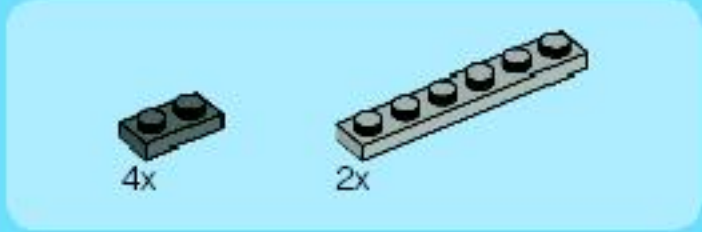
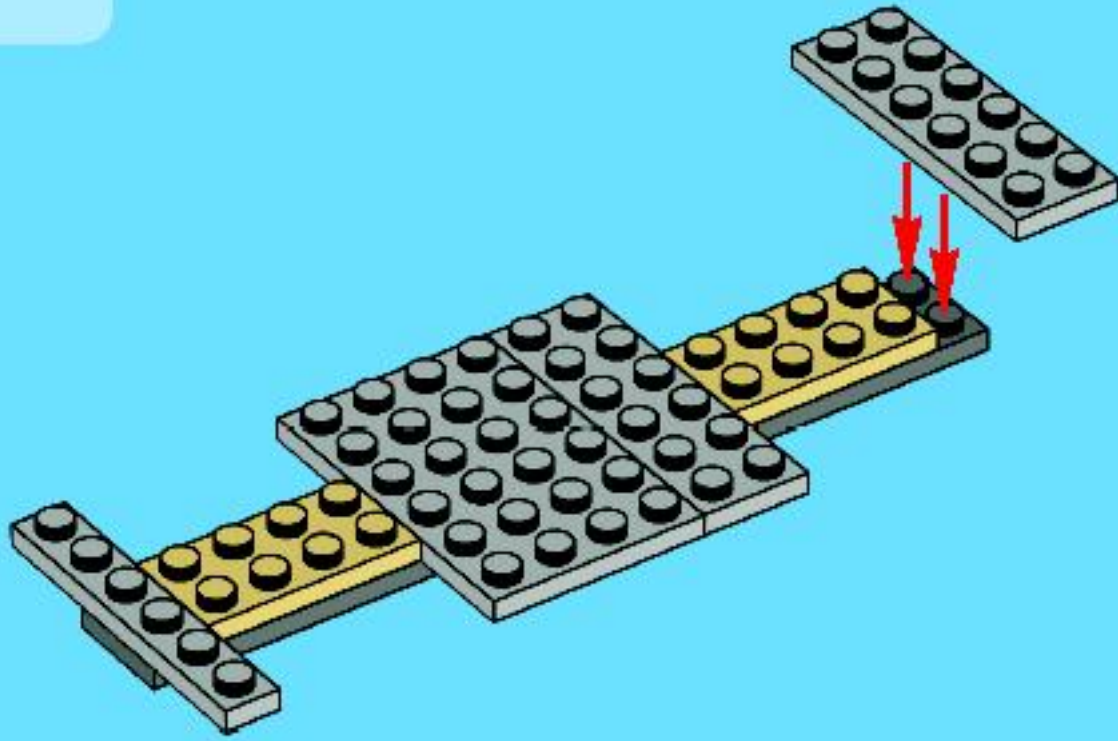

3

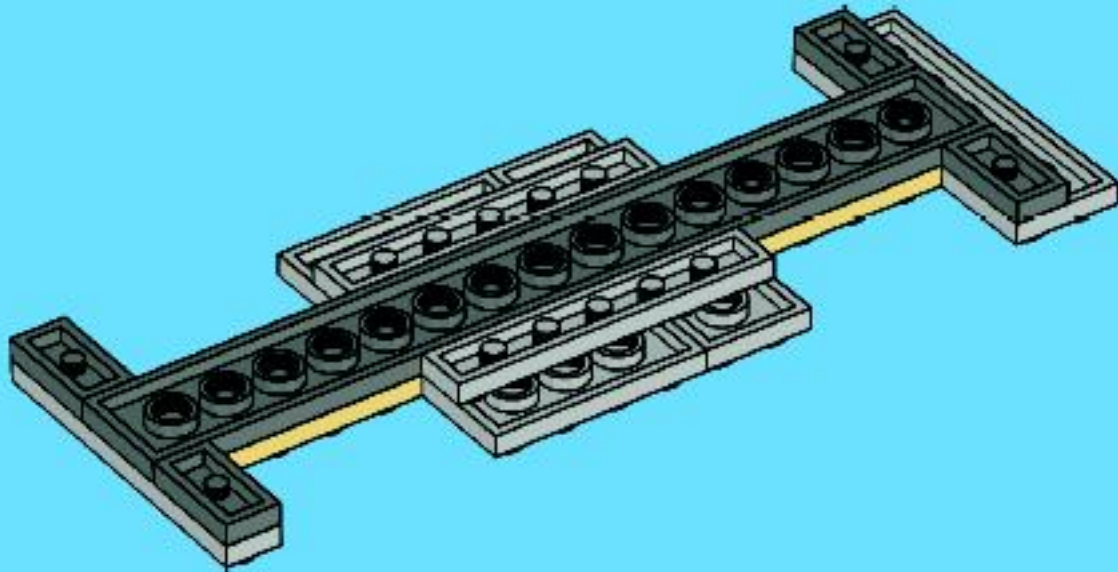

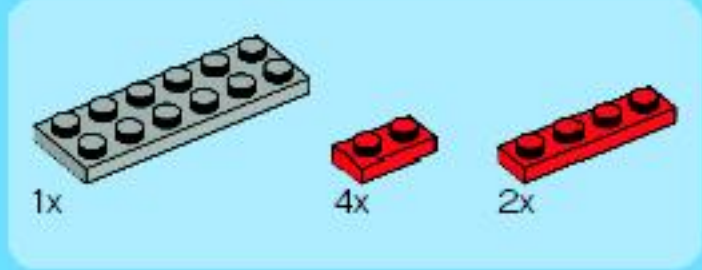

4

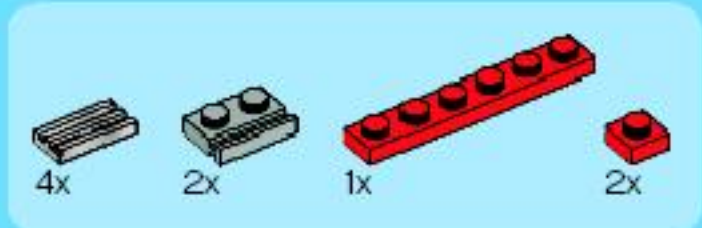
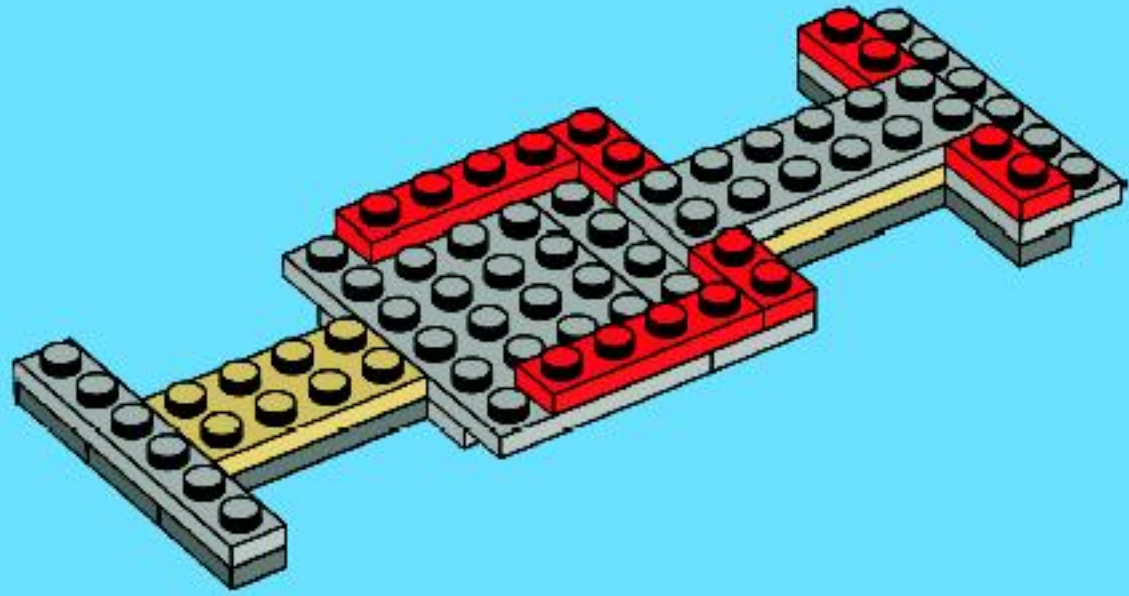

5

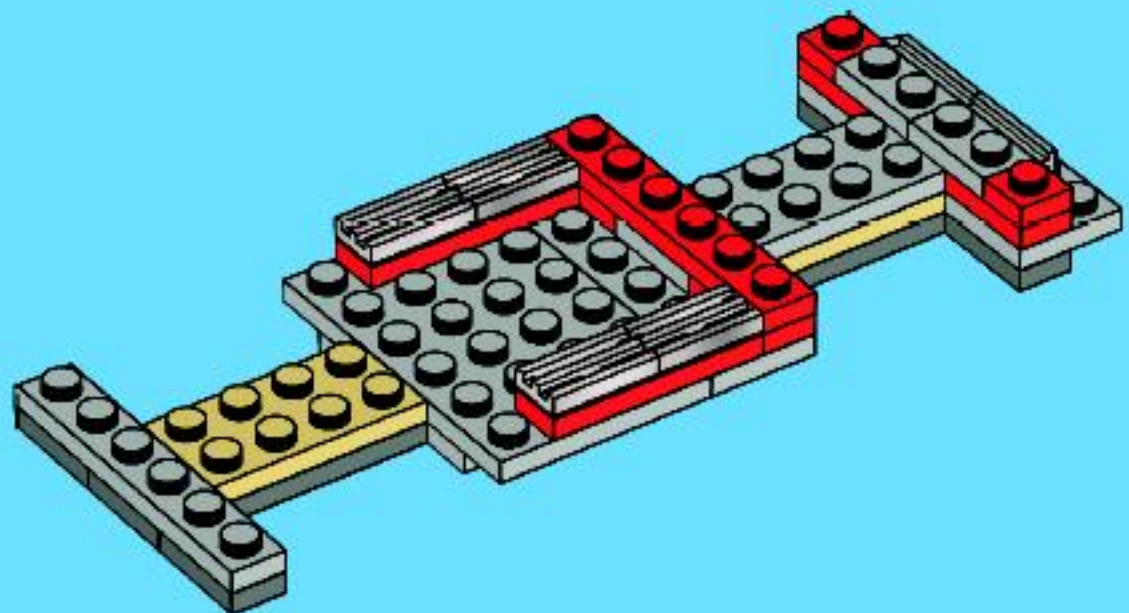

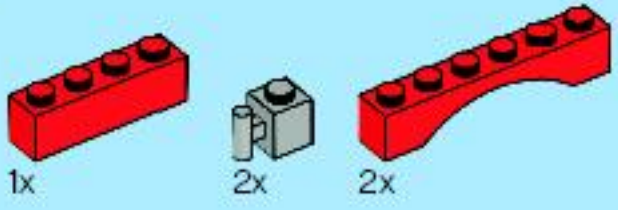

6

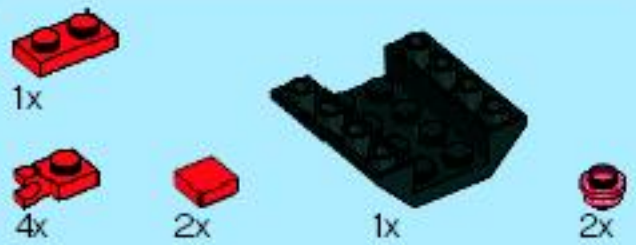
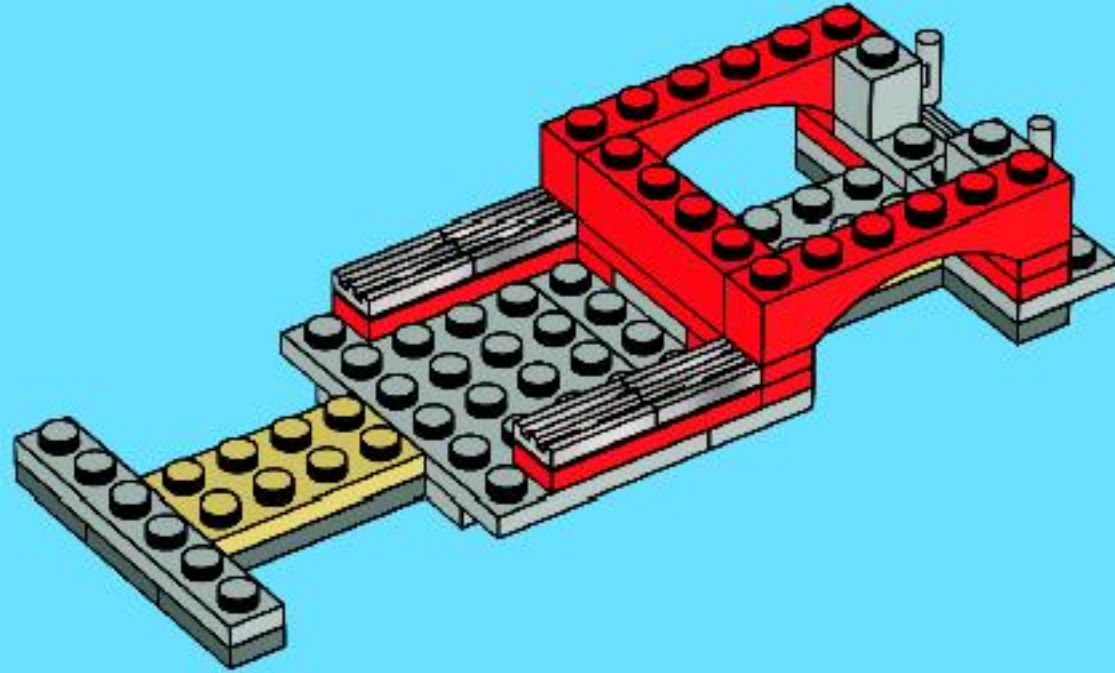

7

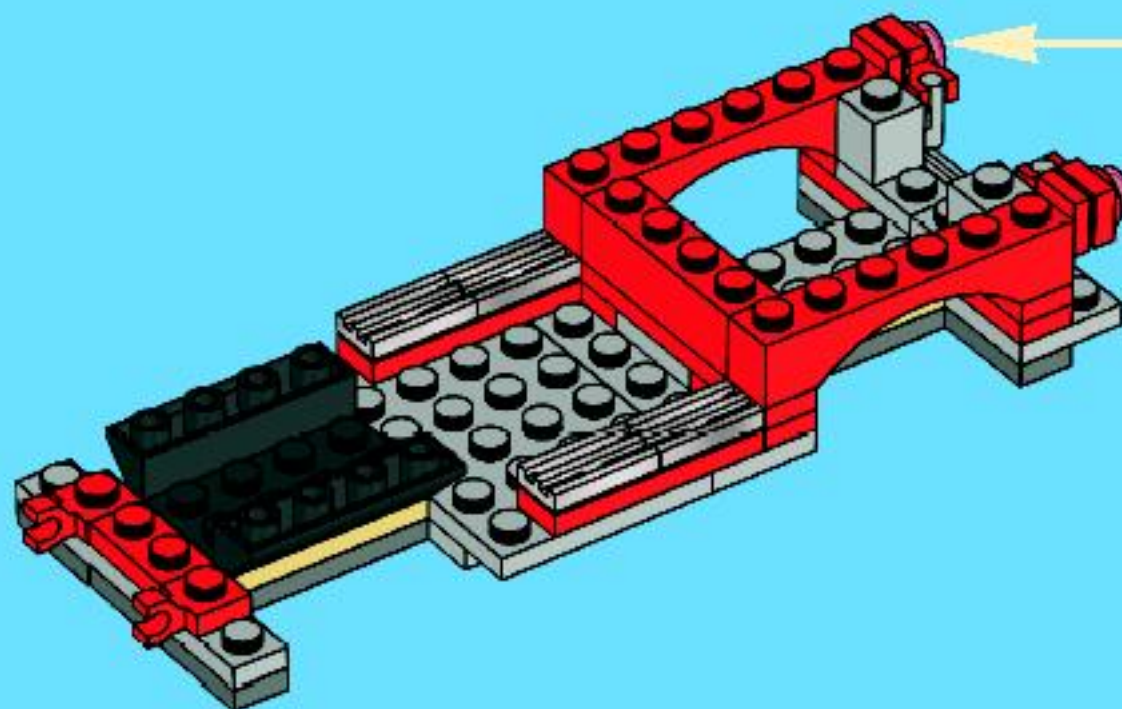
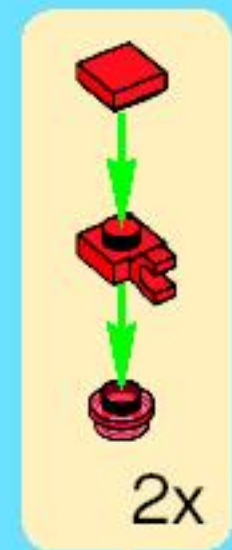



3x



1x



2x

8

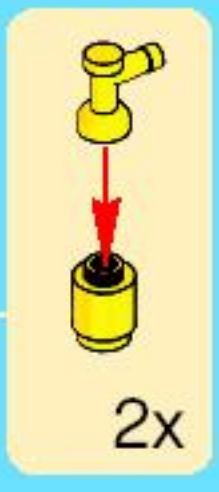
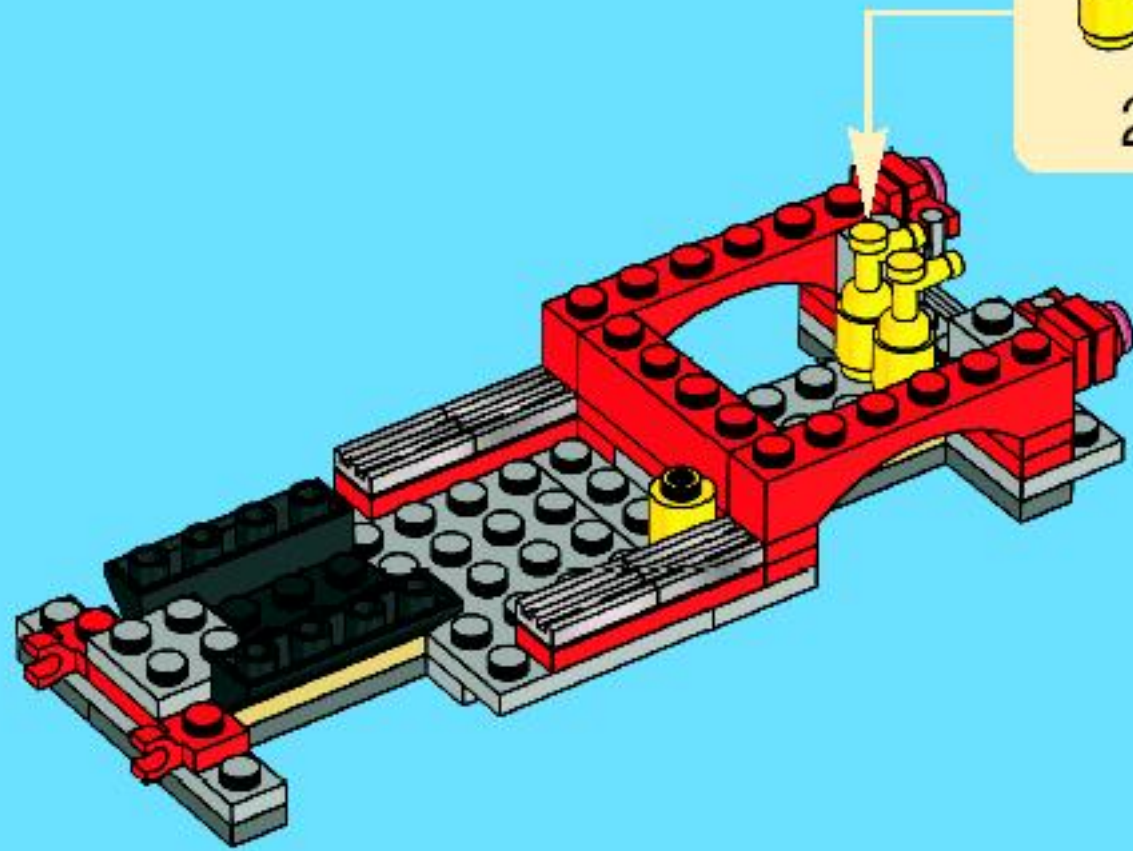

2x



1x



2x



1x



4x



1x

9

1



2



3

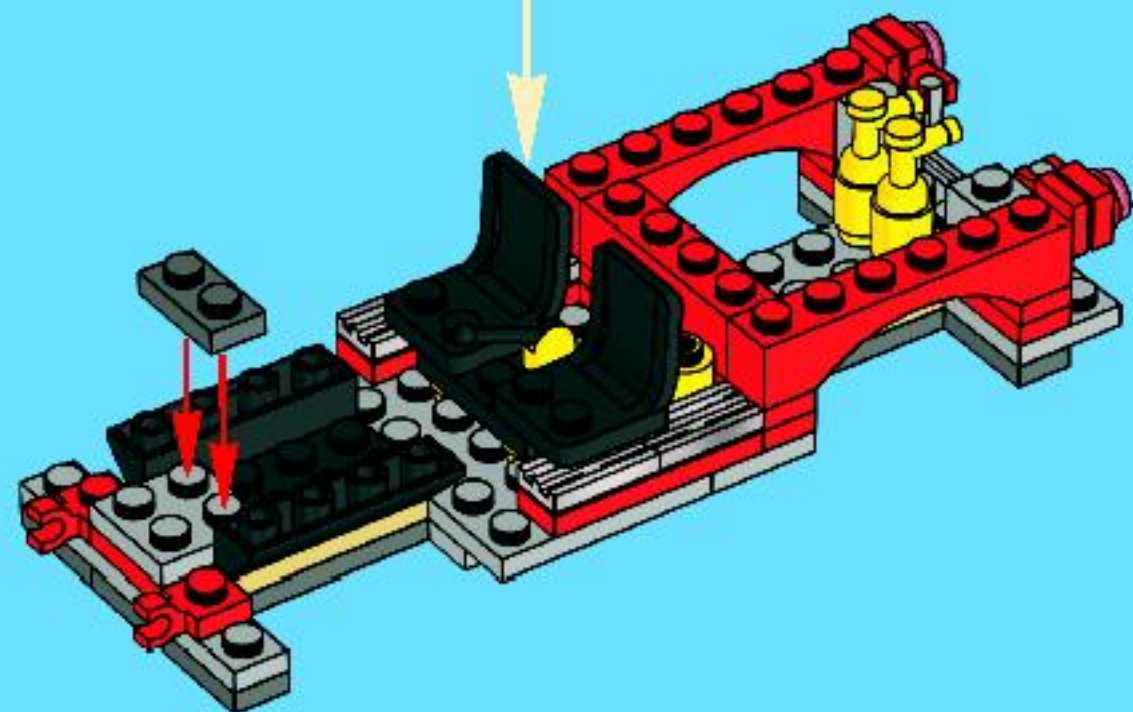



10

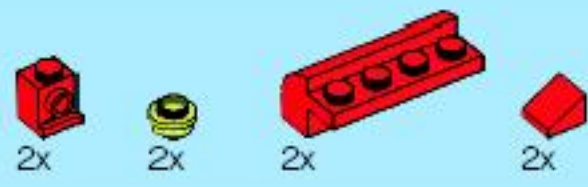
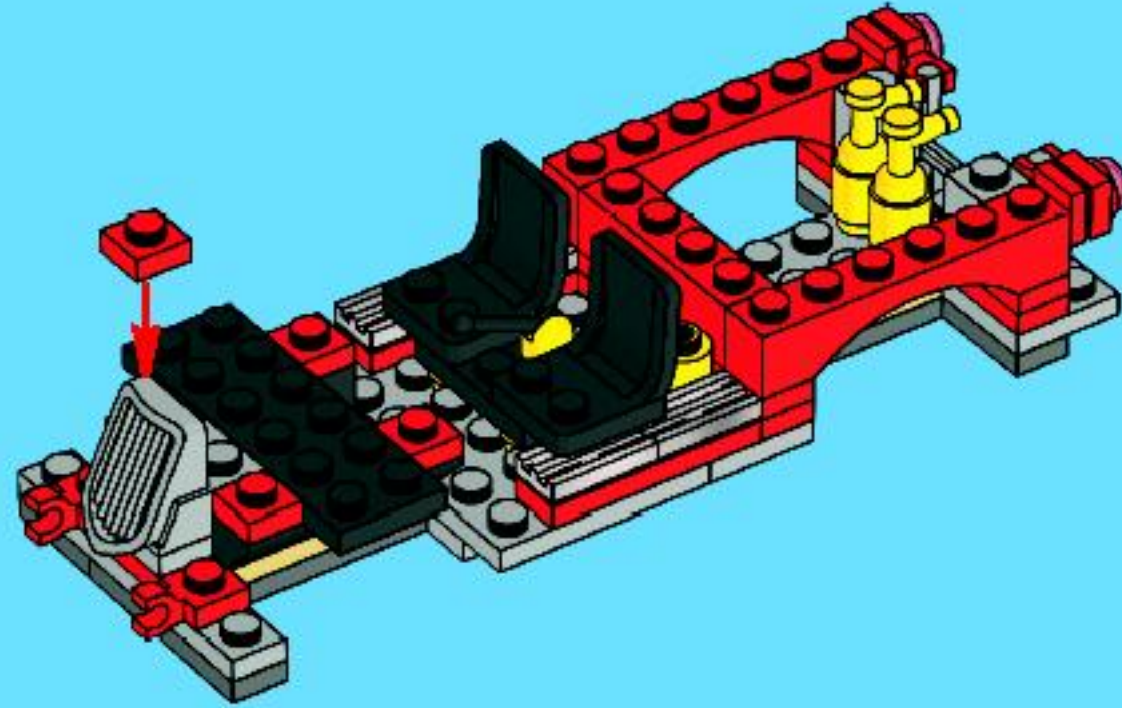

11

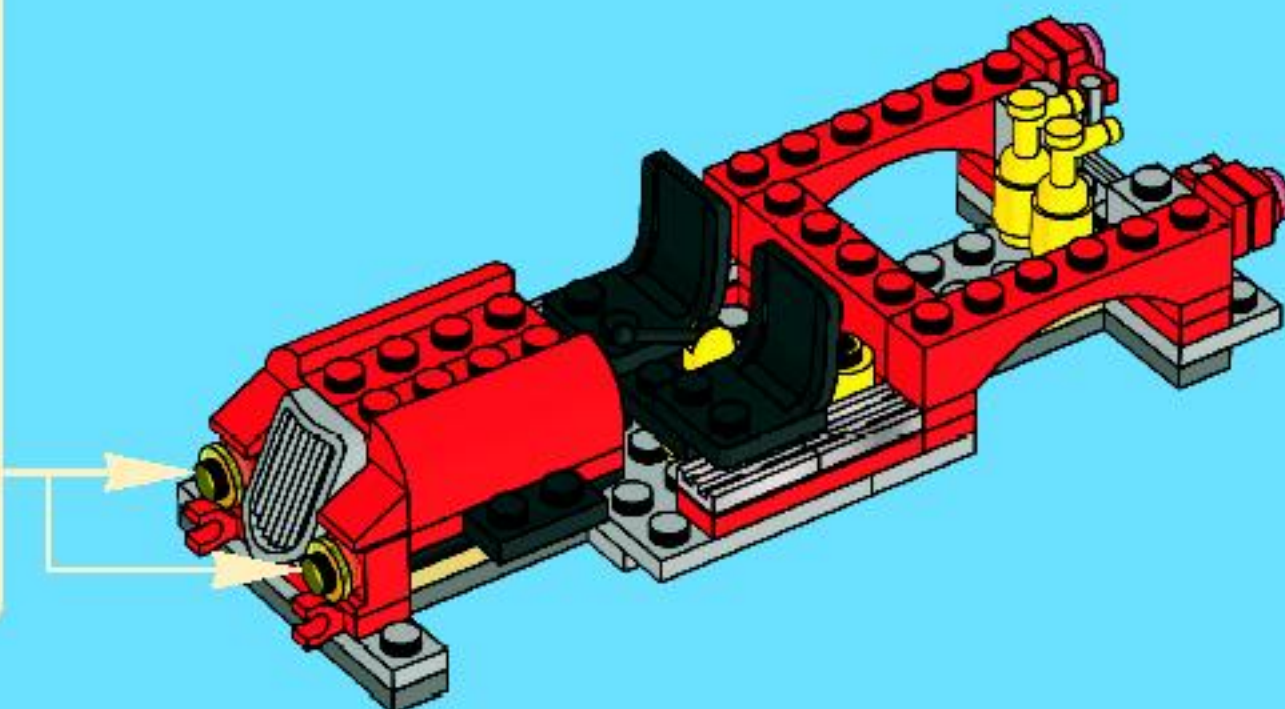
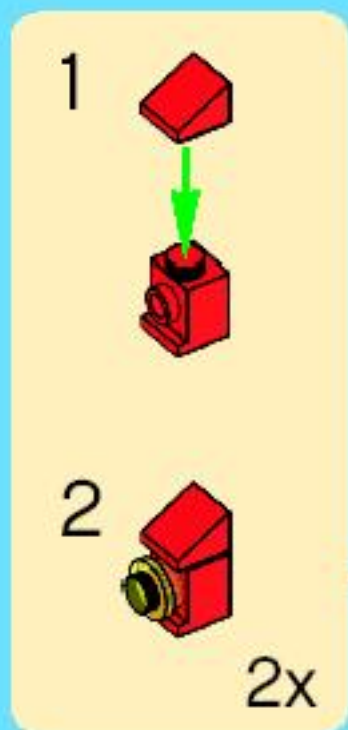



2x



4x

12

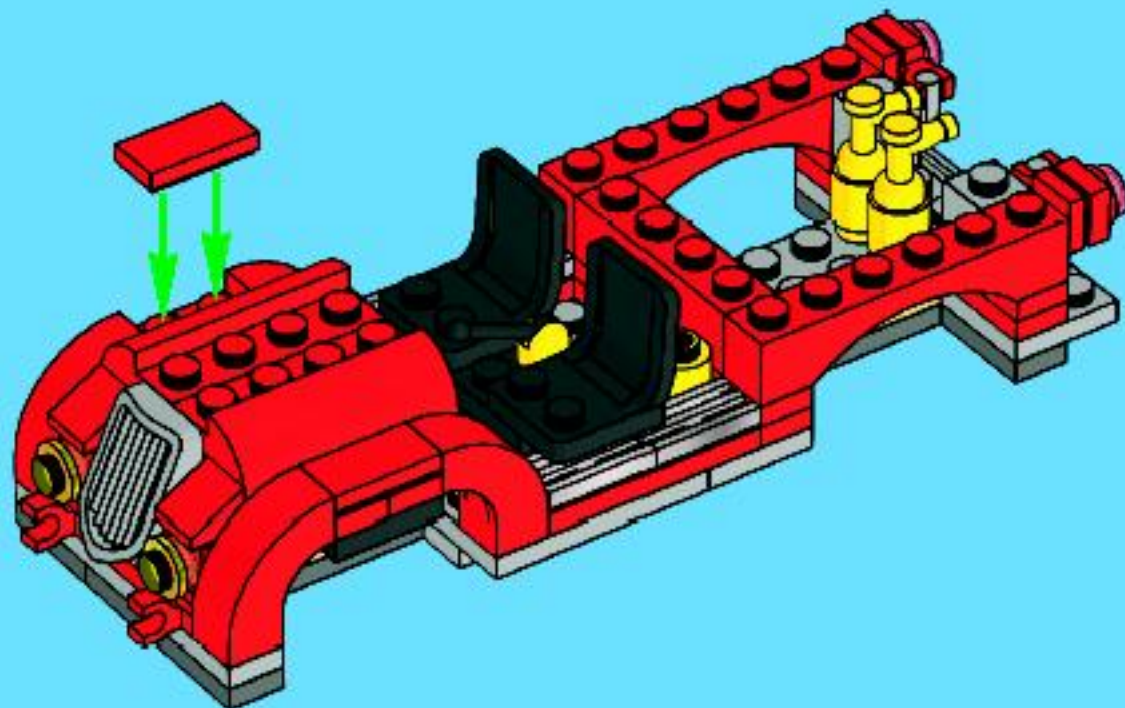

1x



1x



1x



1x



2x



1x

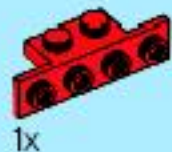

1x

1

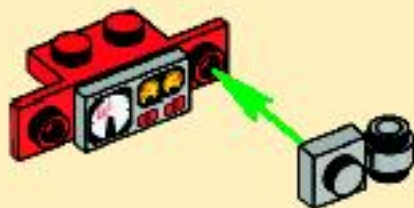

2



13

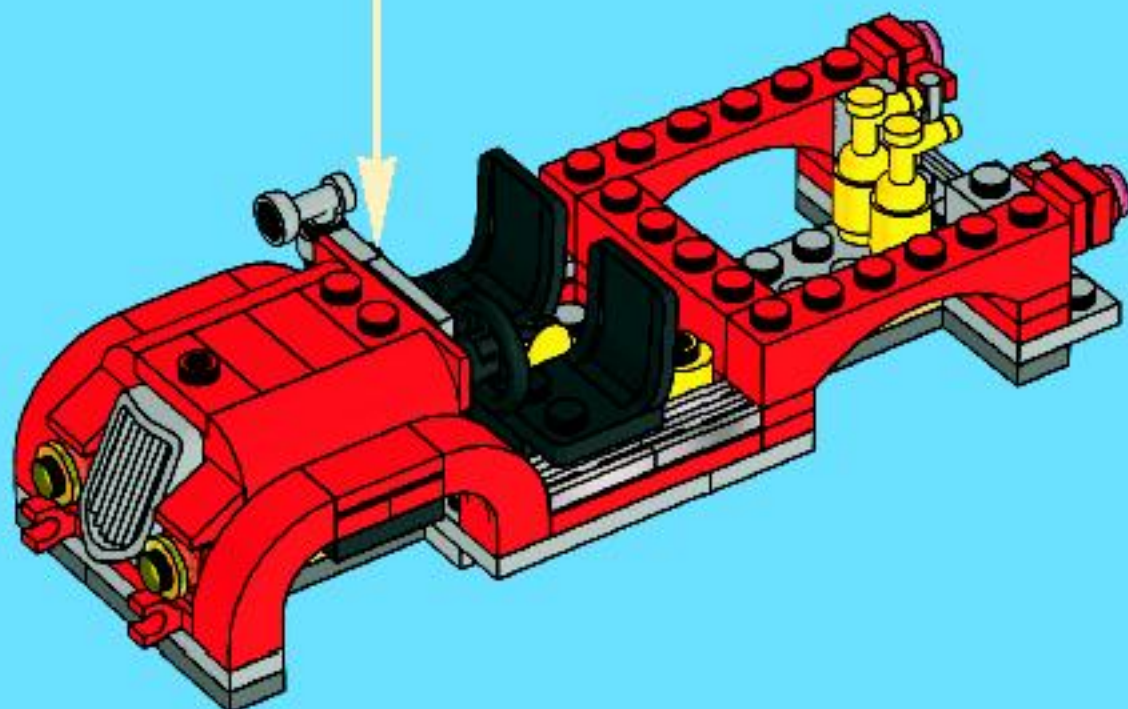



14

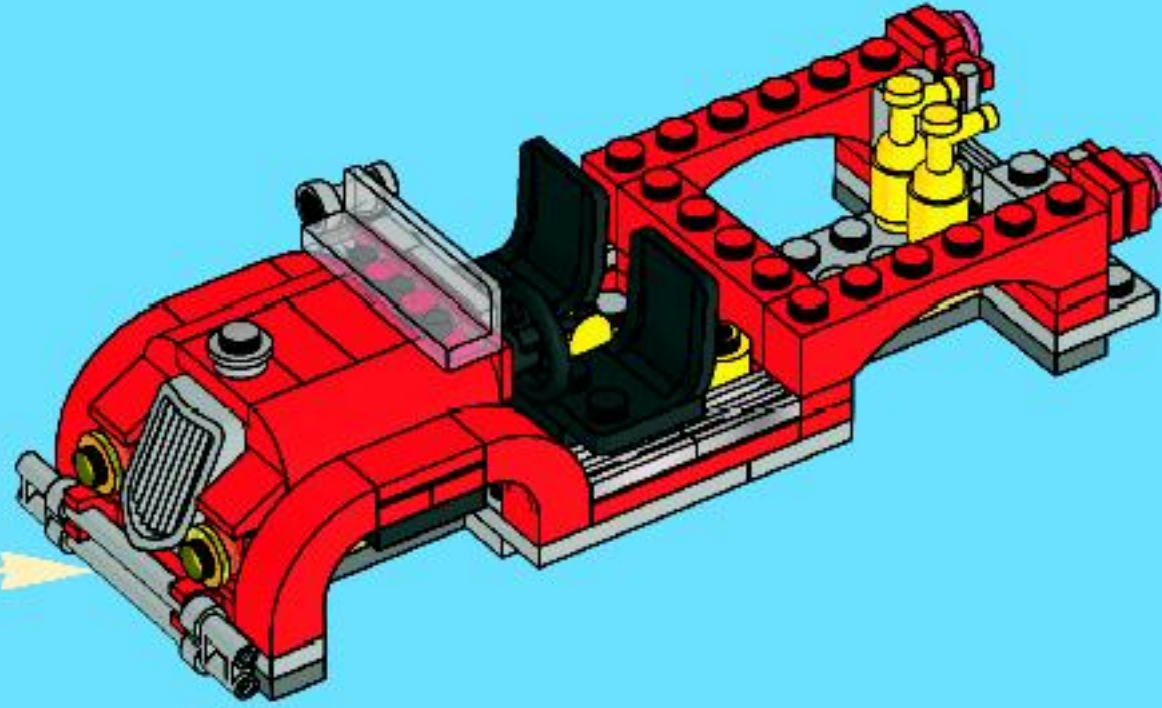
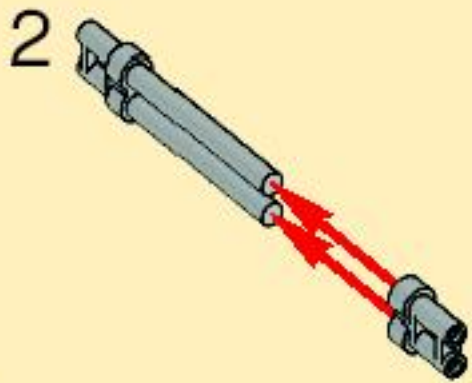
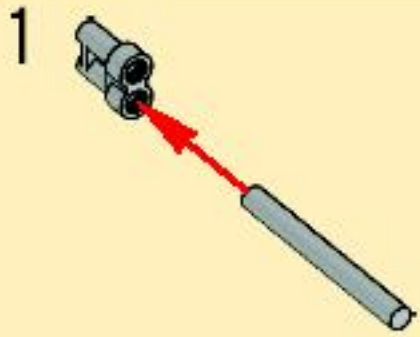

15

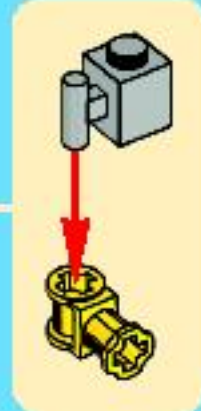
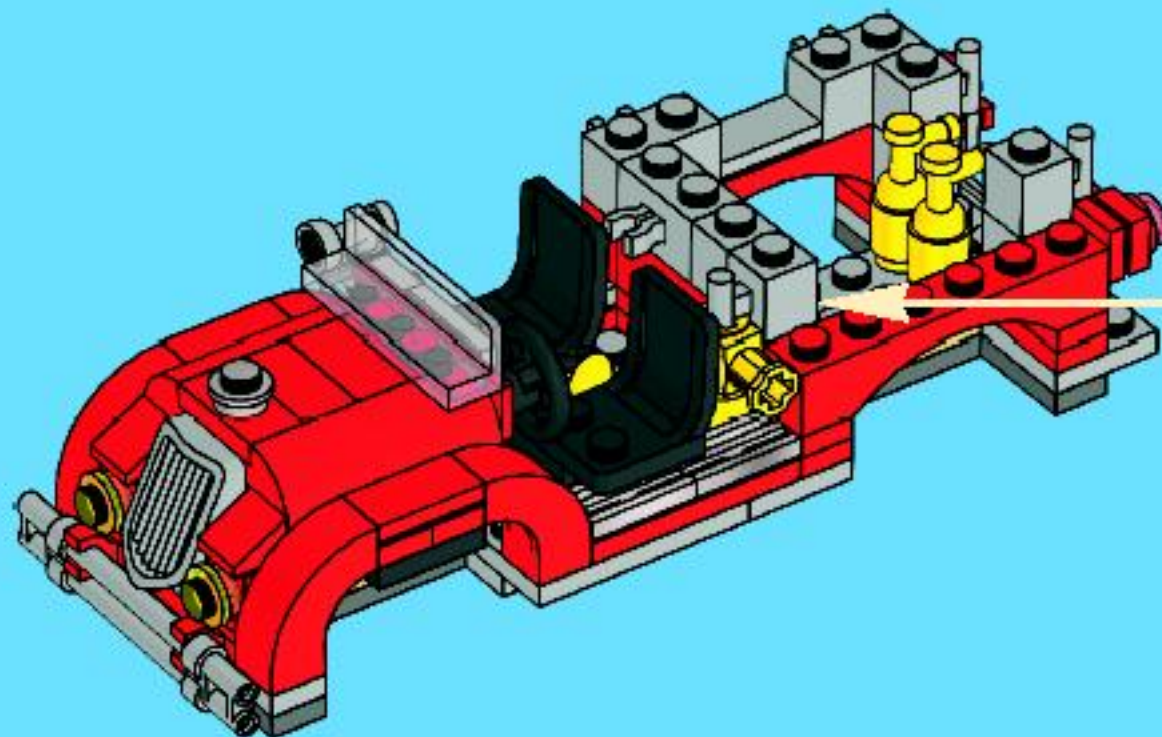

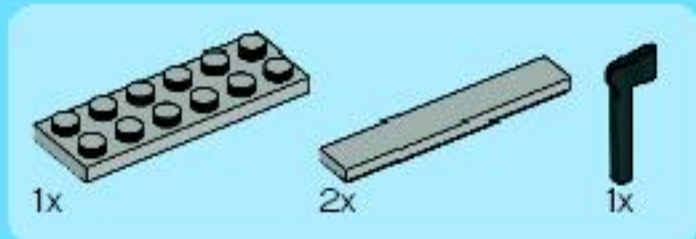

16

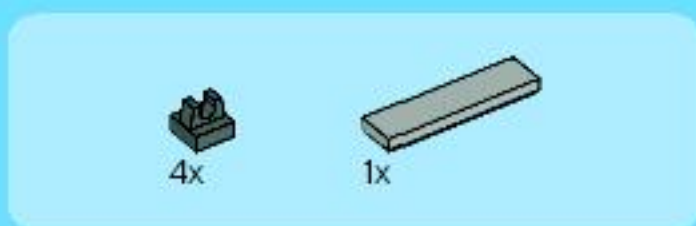
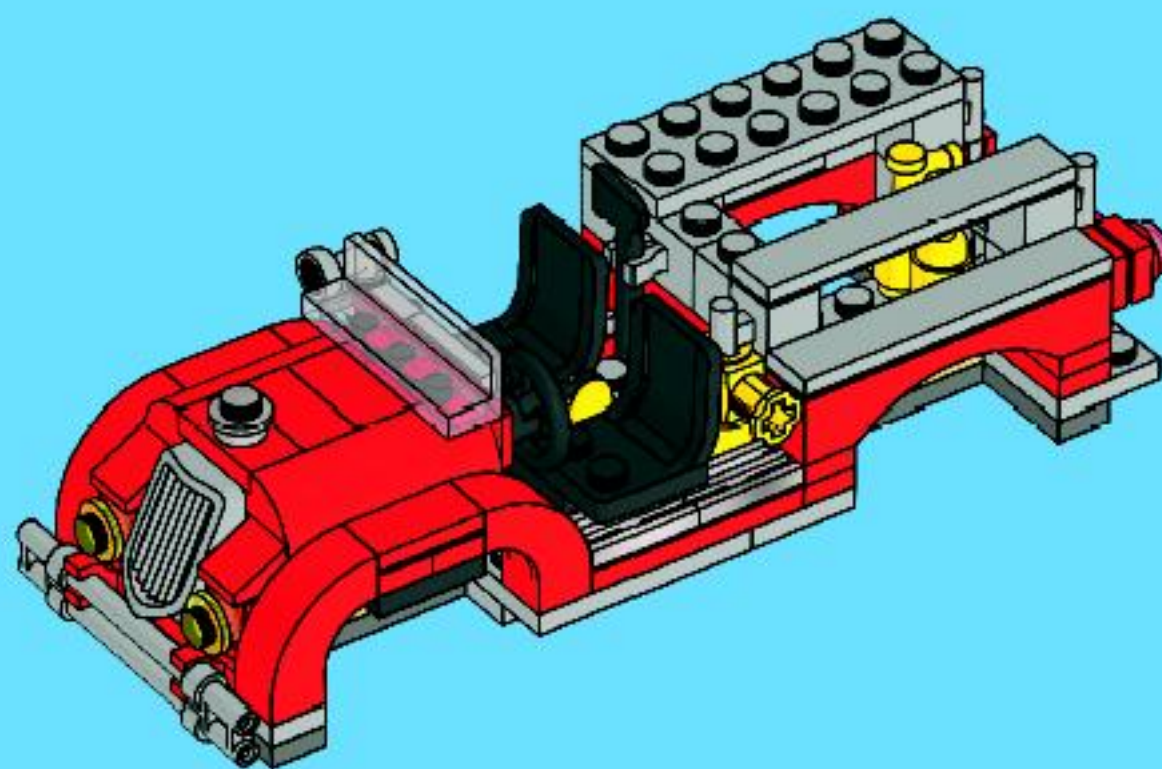

17

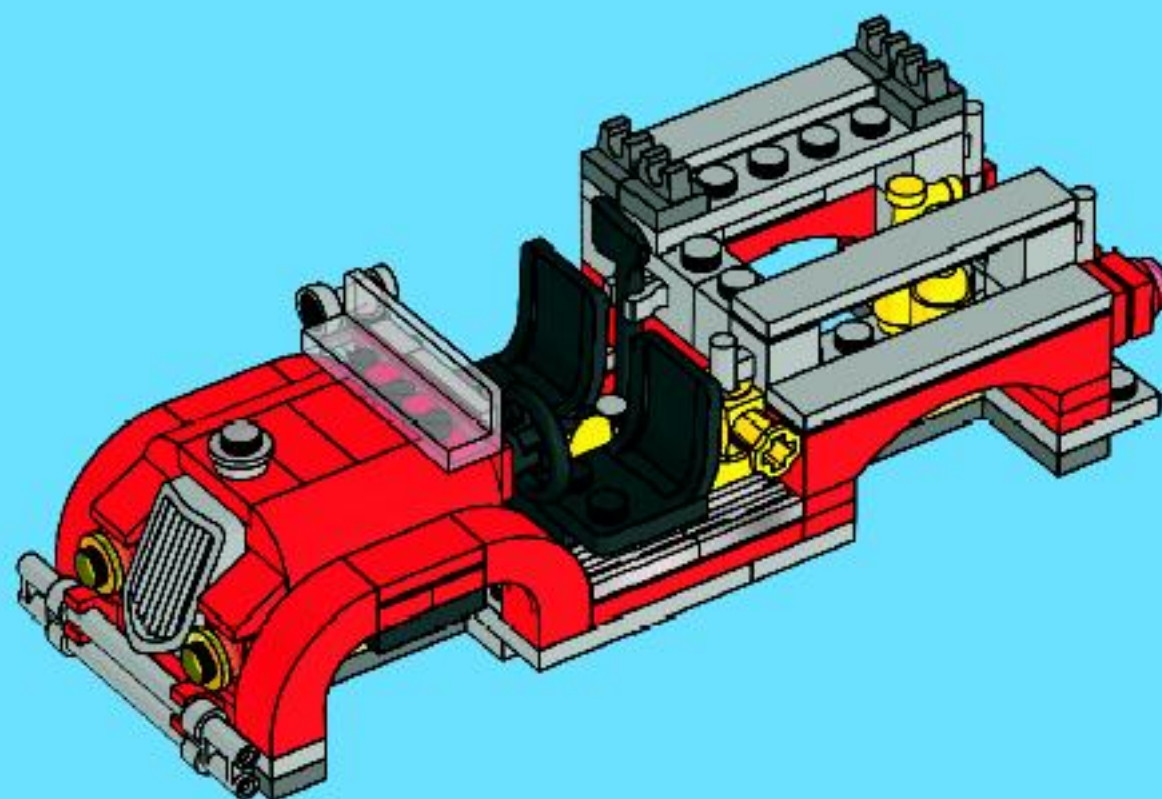

18

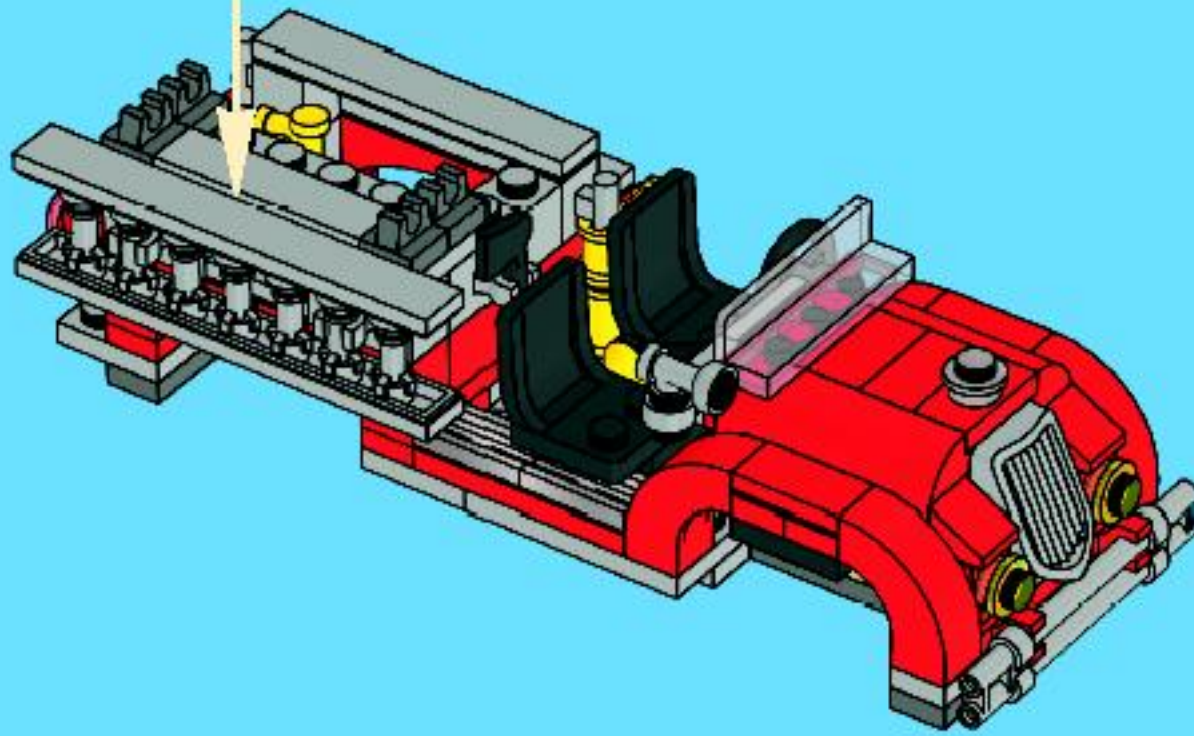
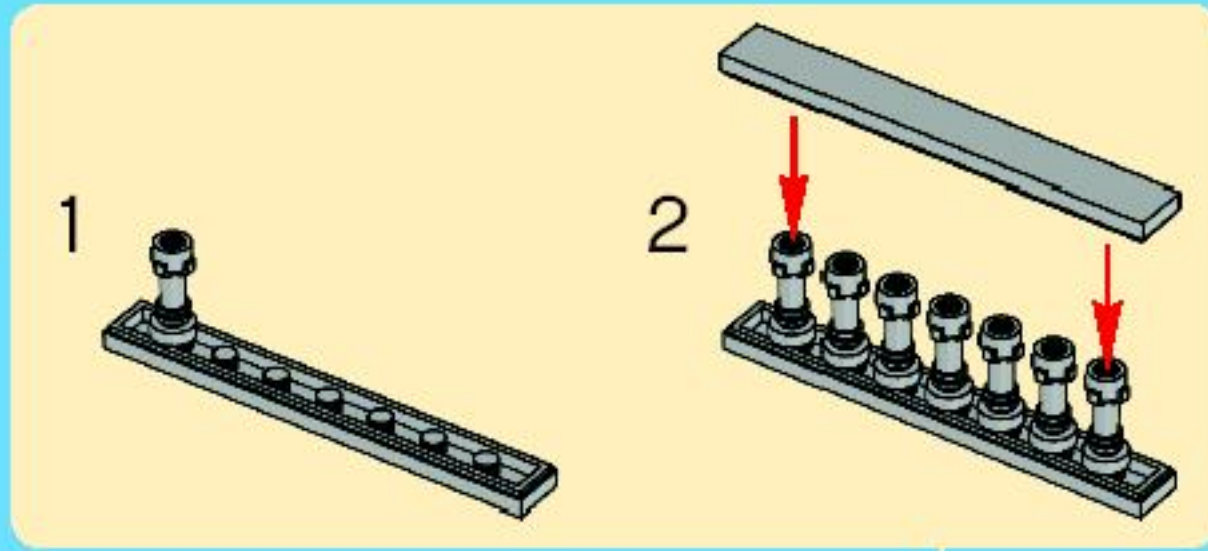
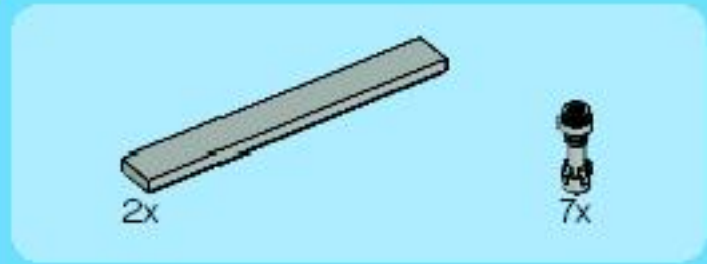

19

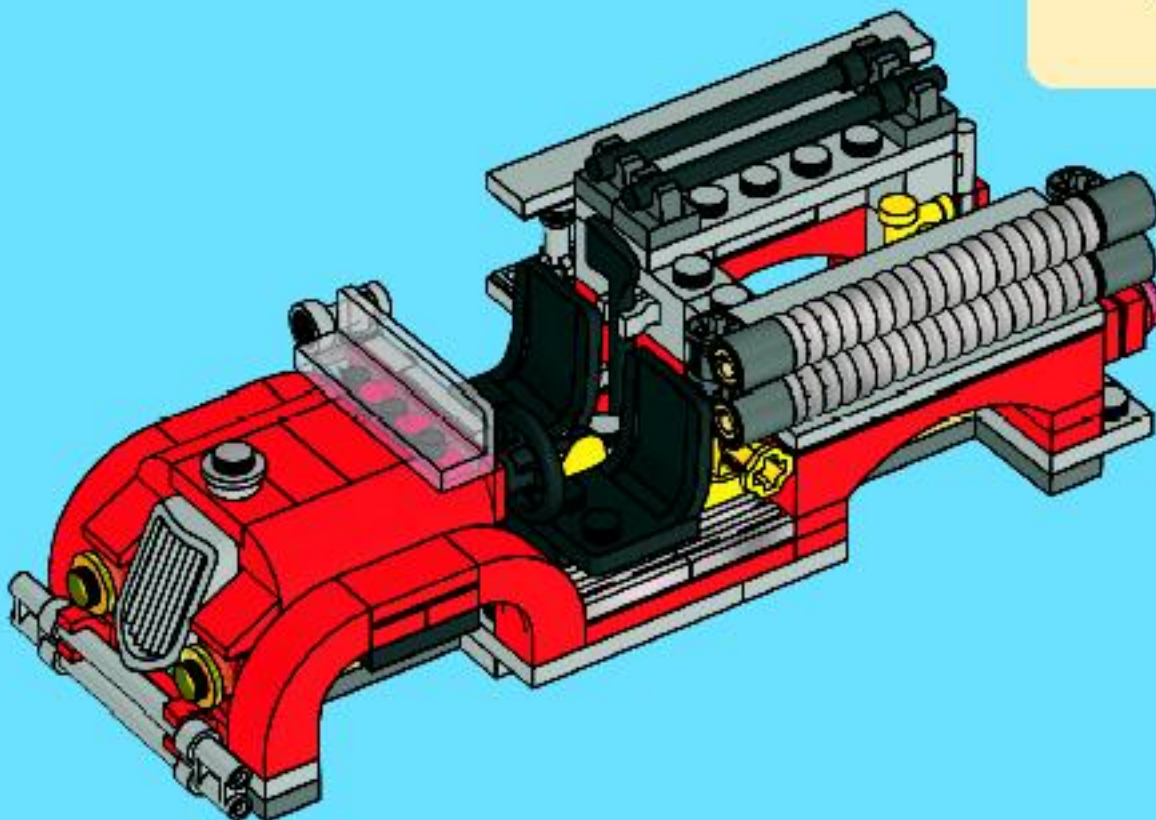
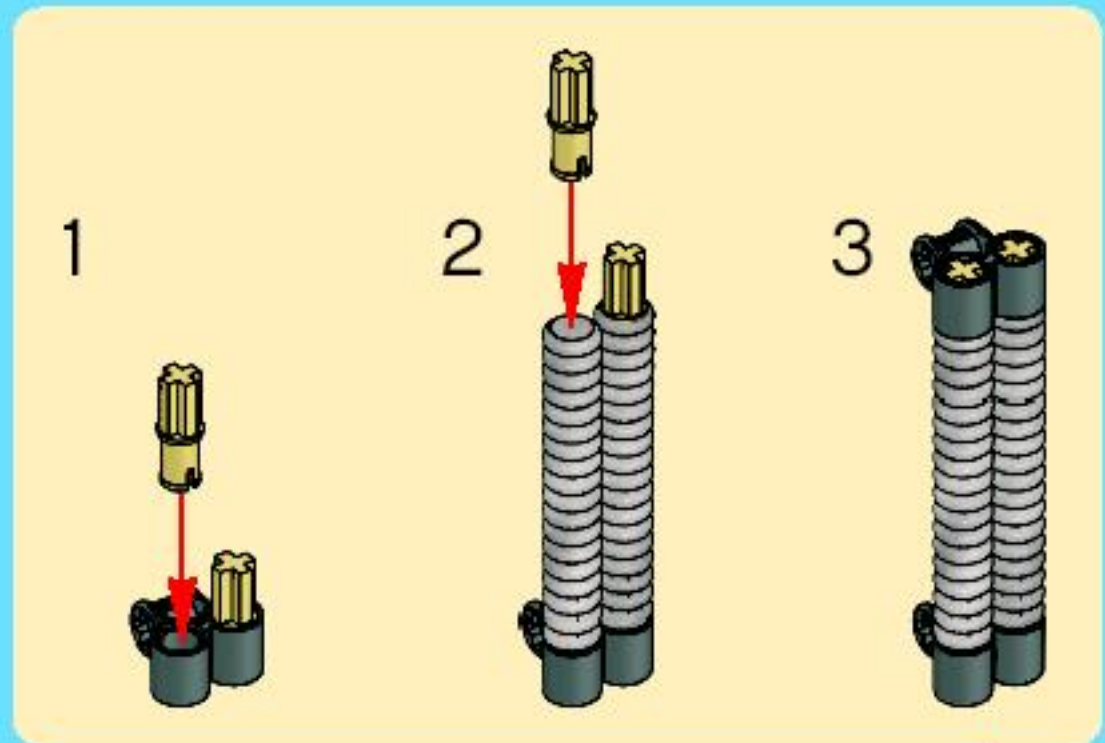
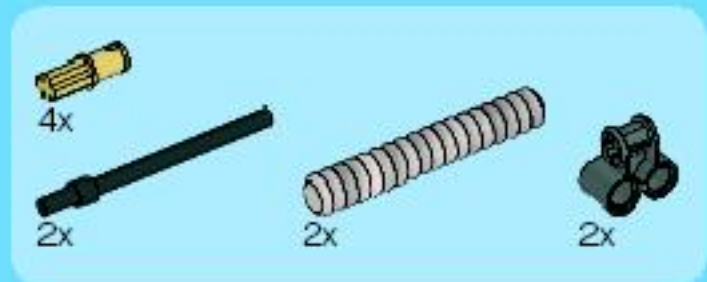



1x



1x



1x

1



2



20

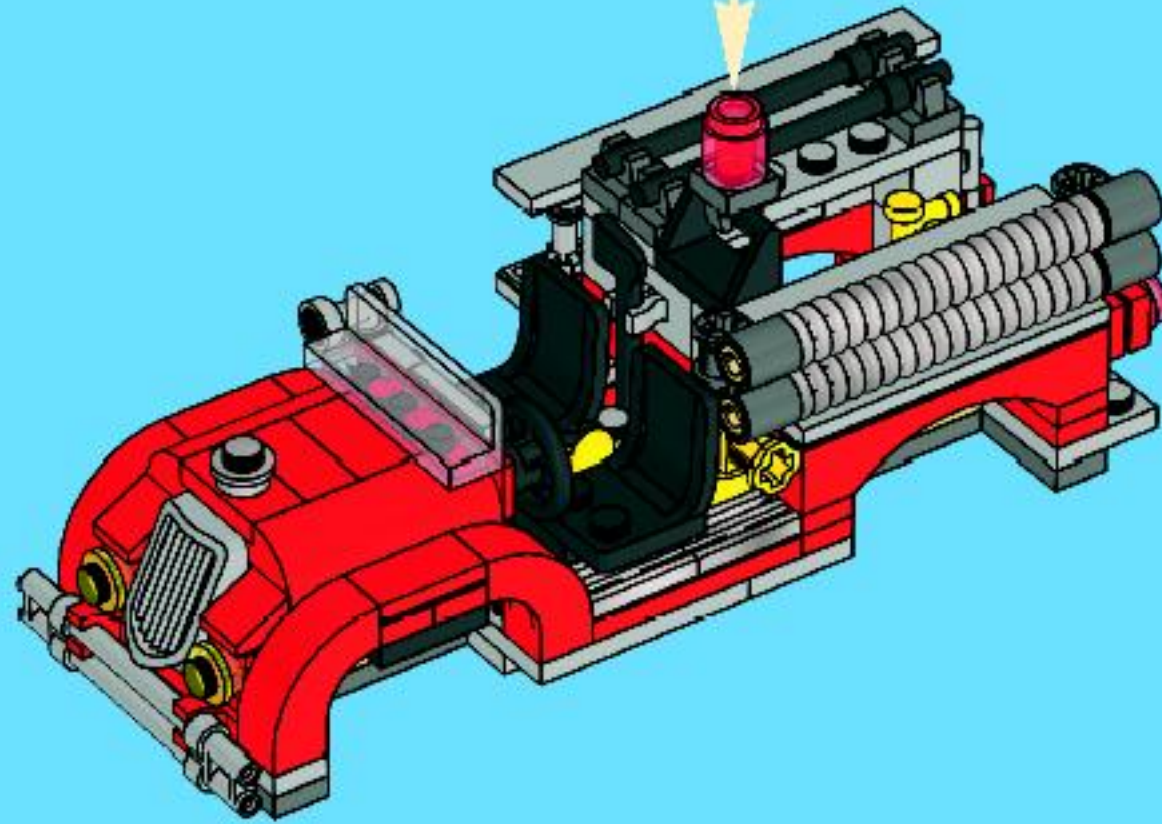

1x



4x



4x



2x

1



2



2x

21

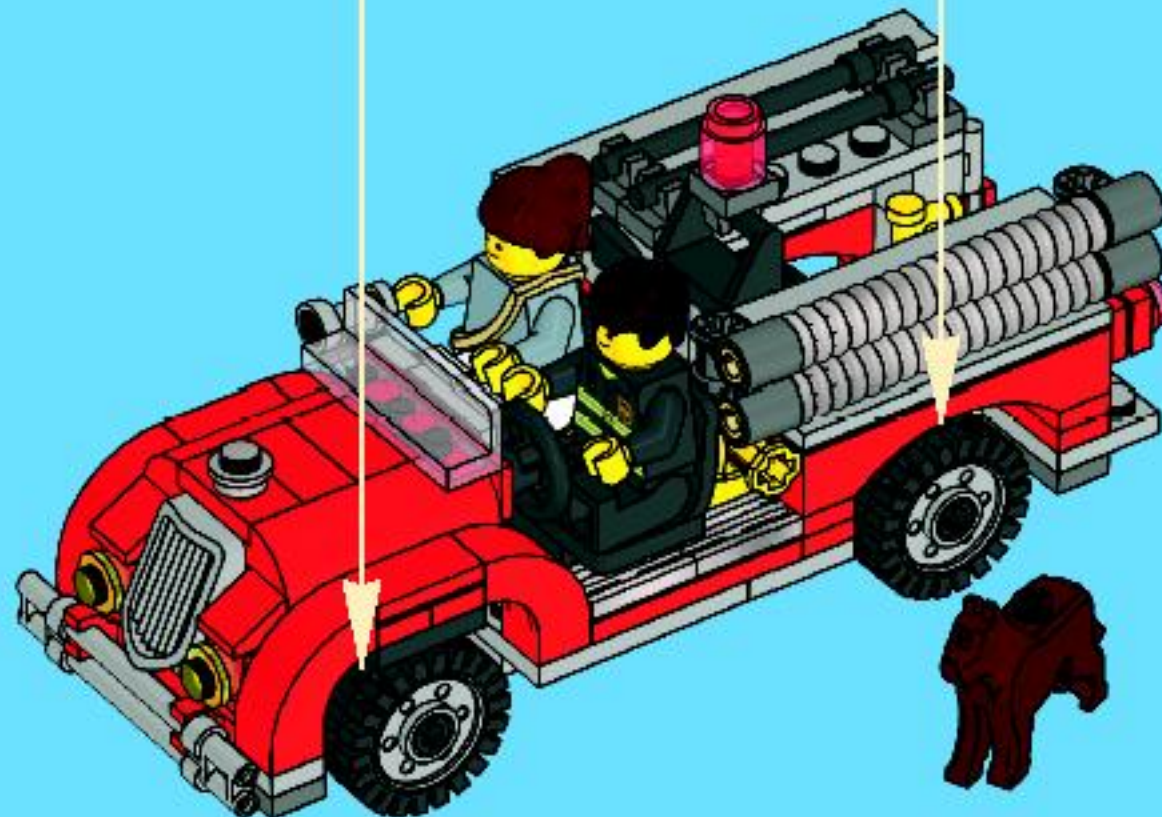

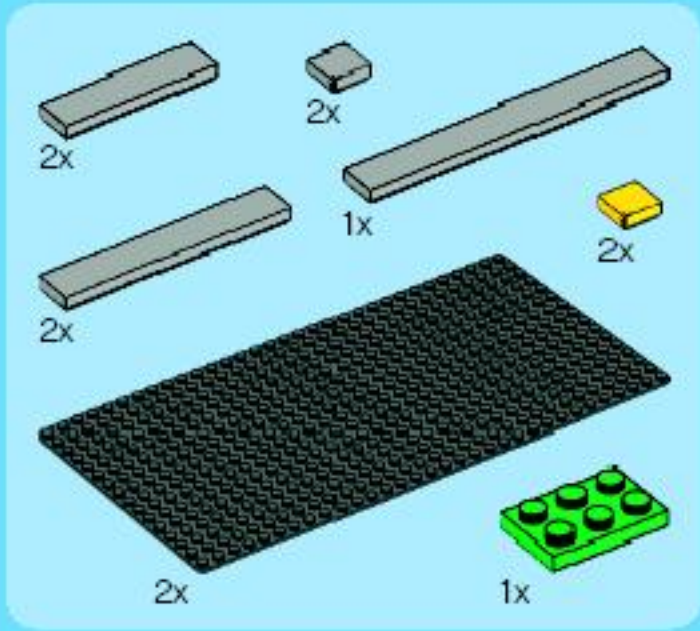

1

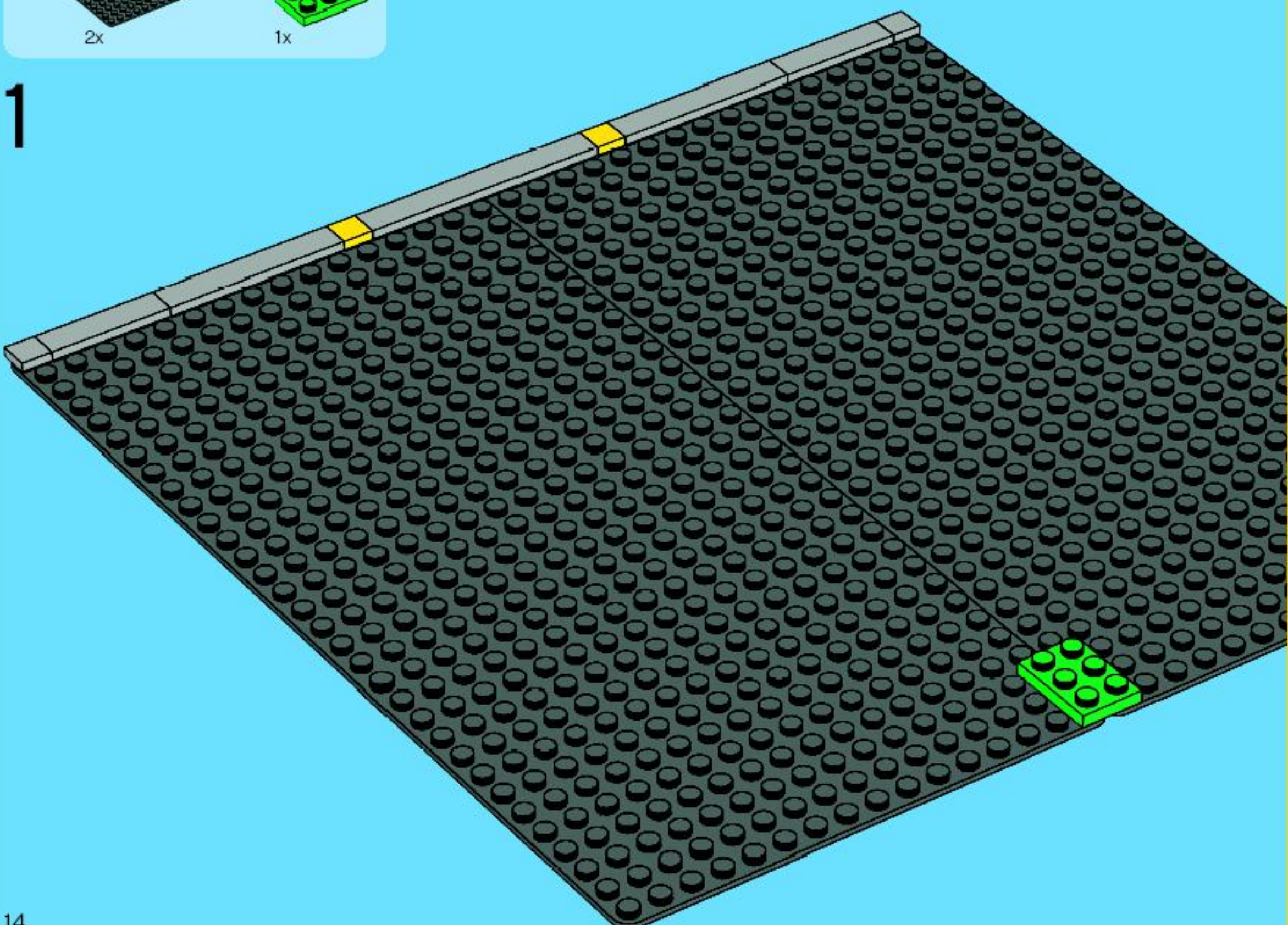

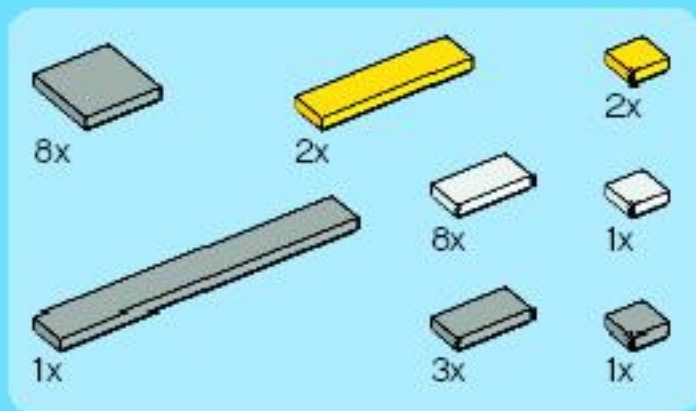

2

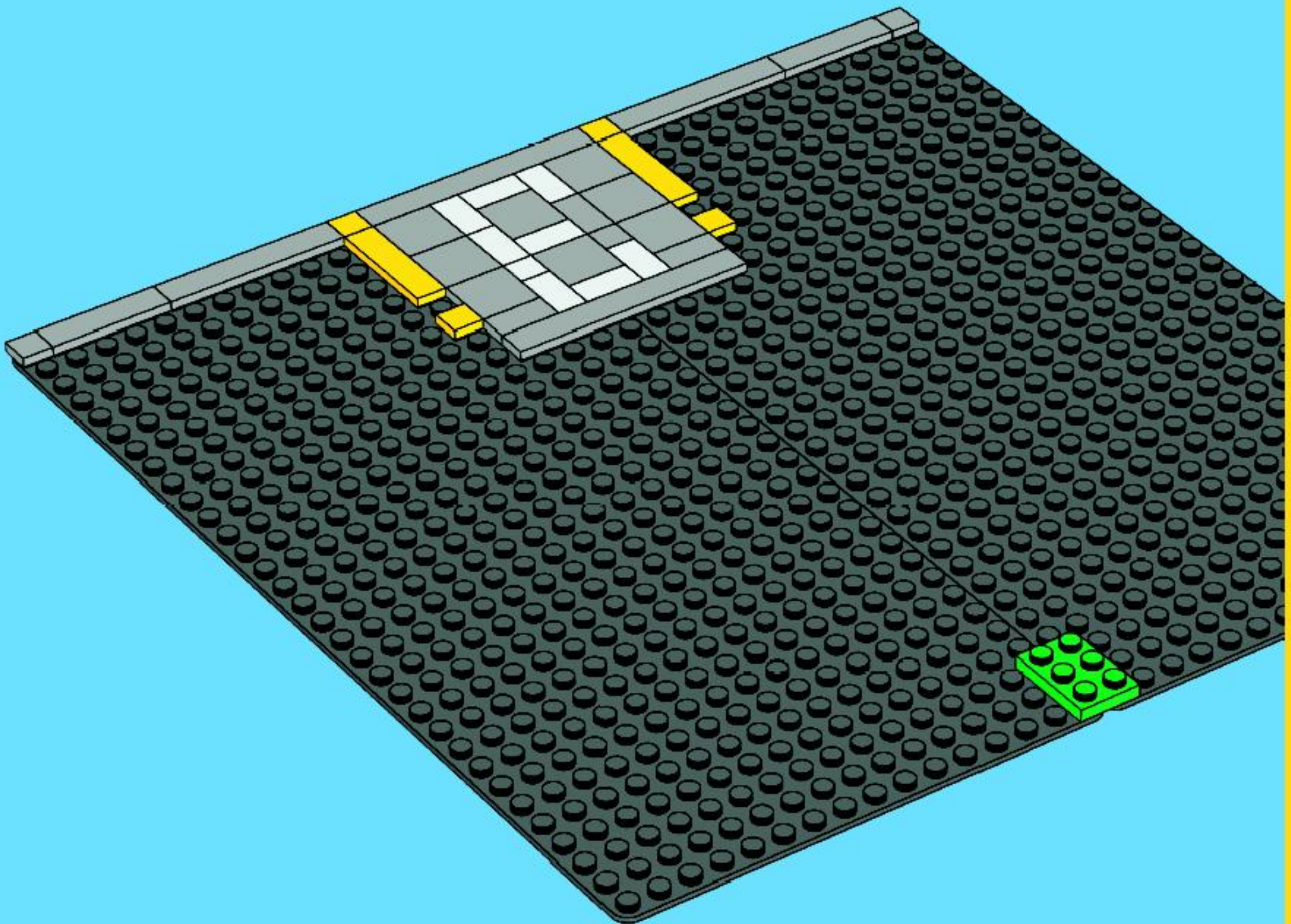

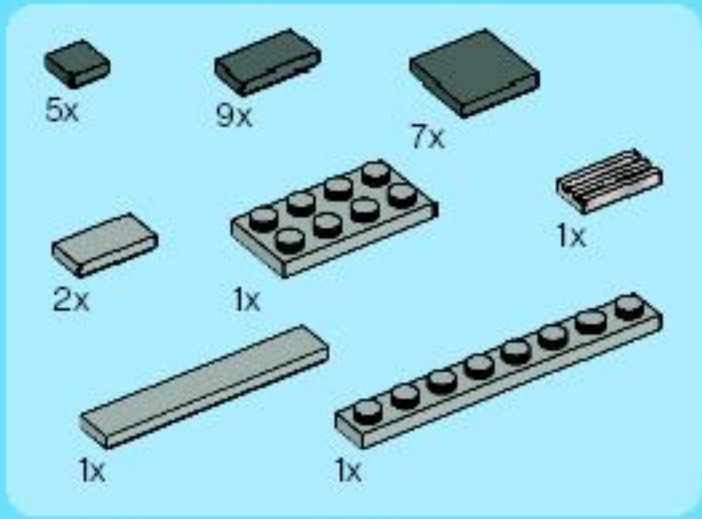

3

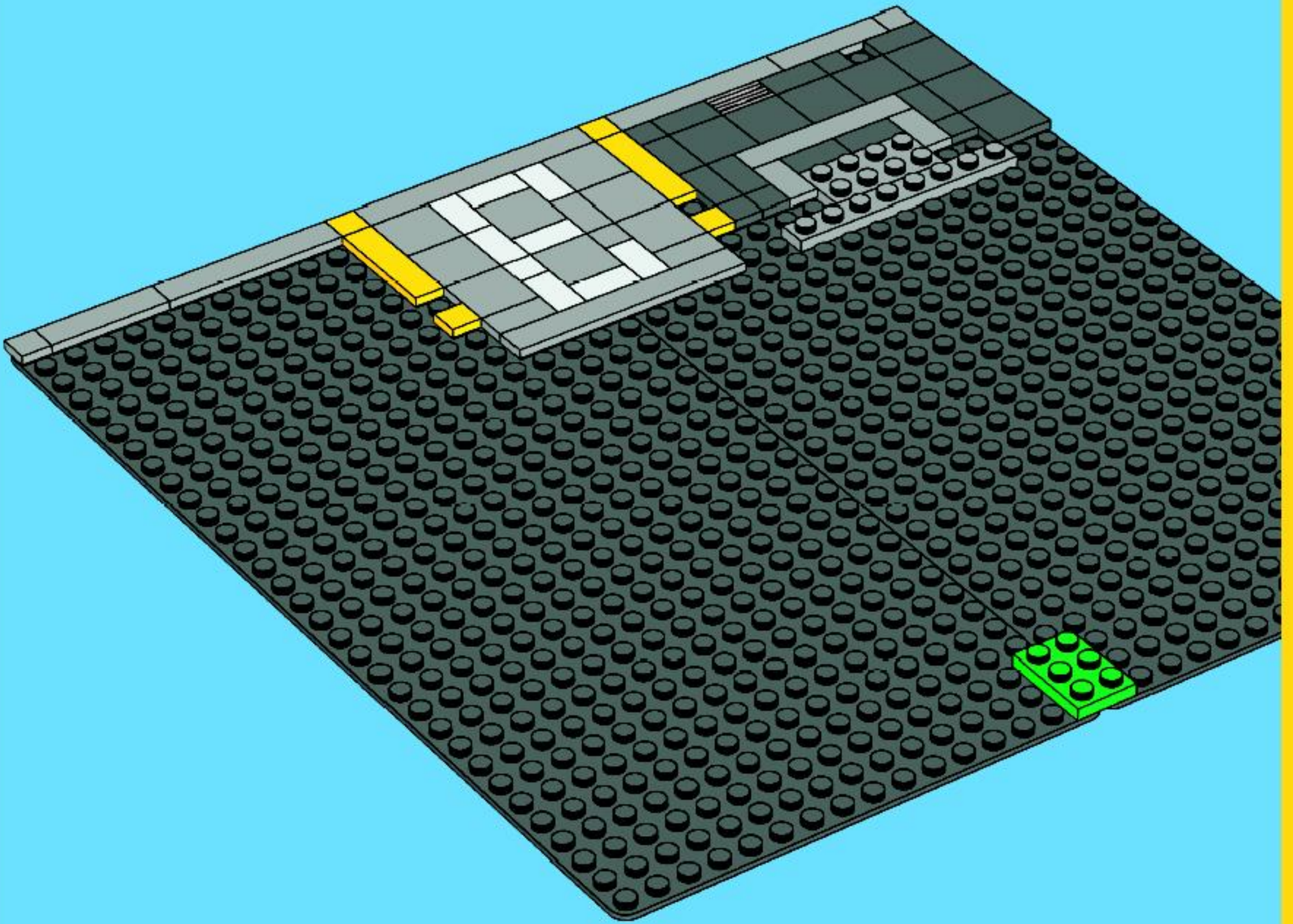

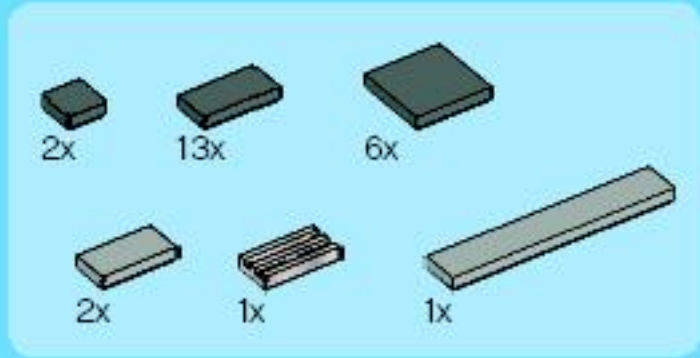

4

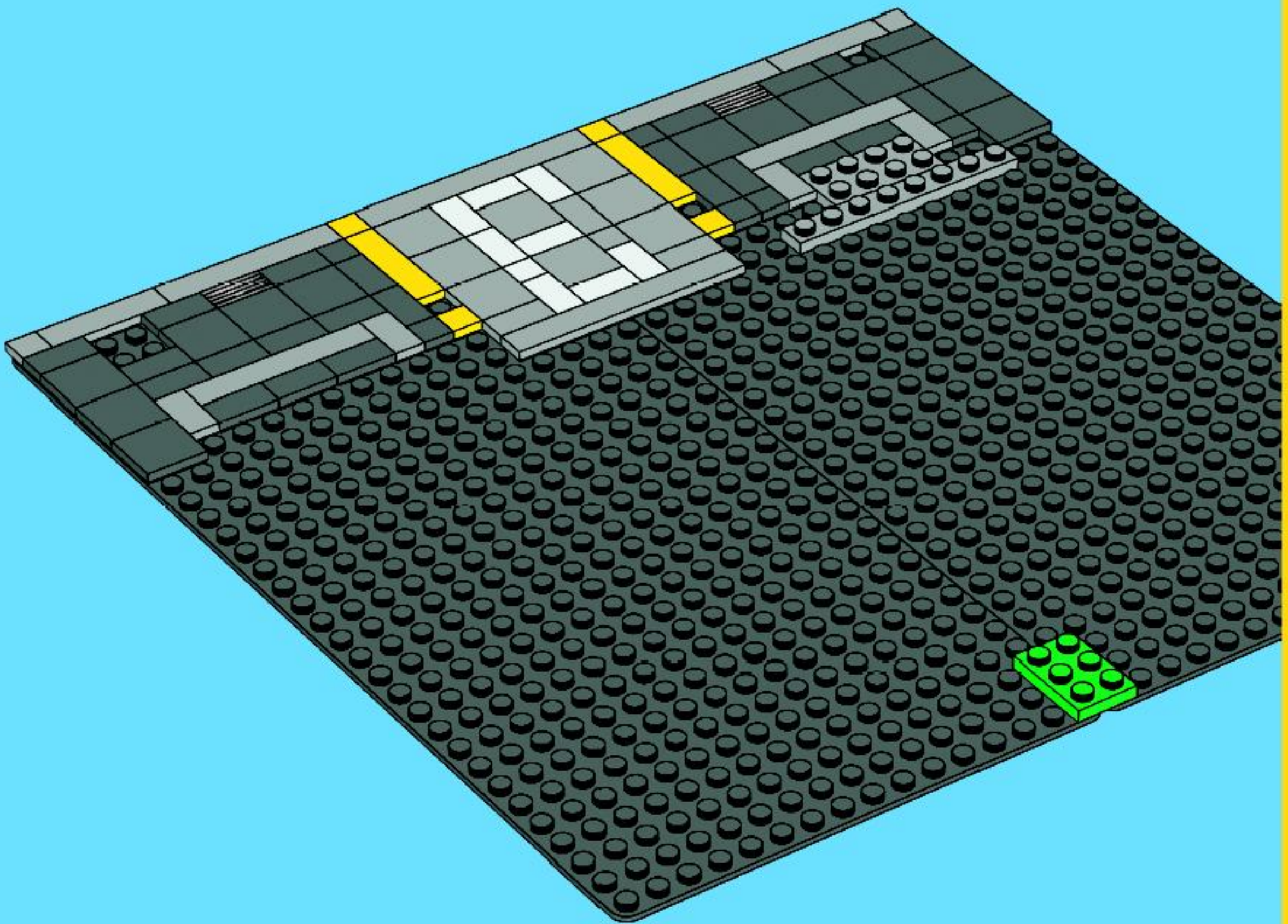

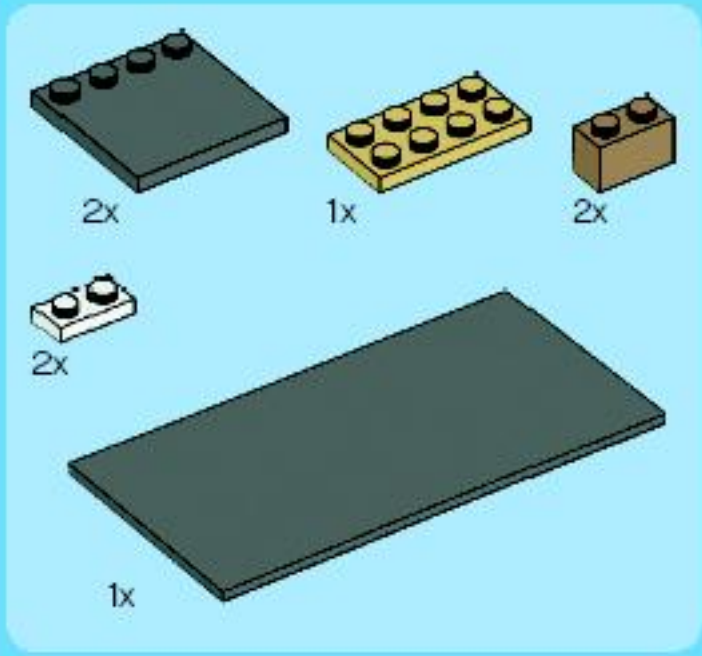

5

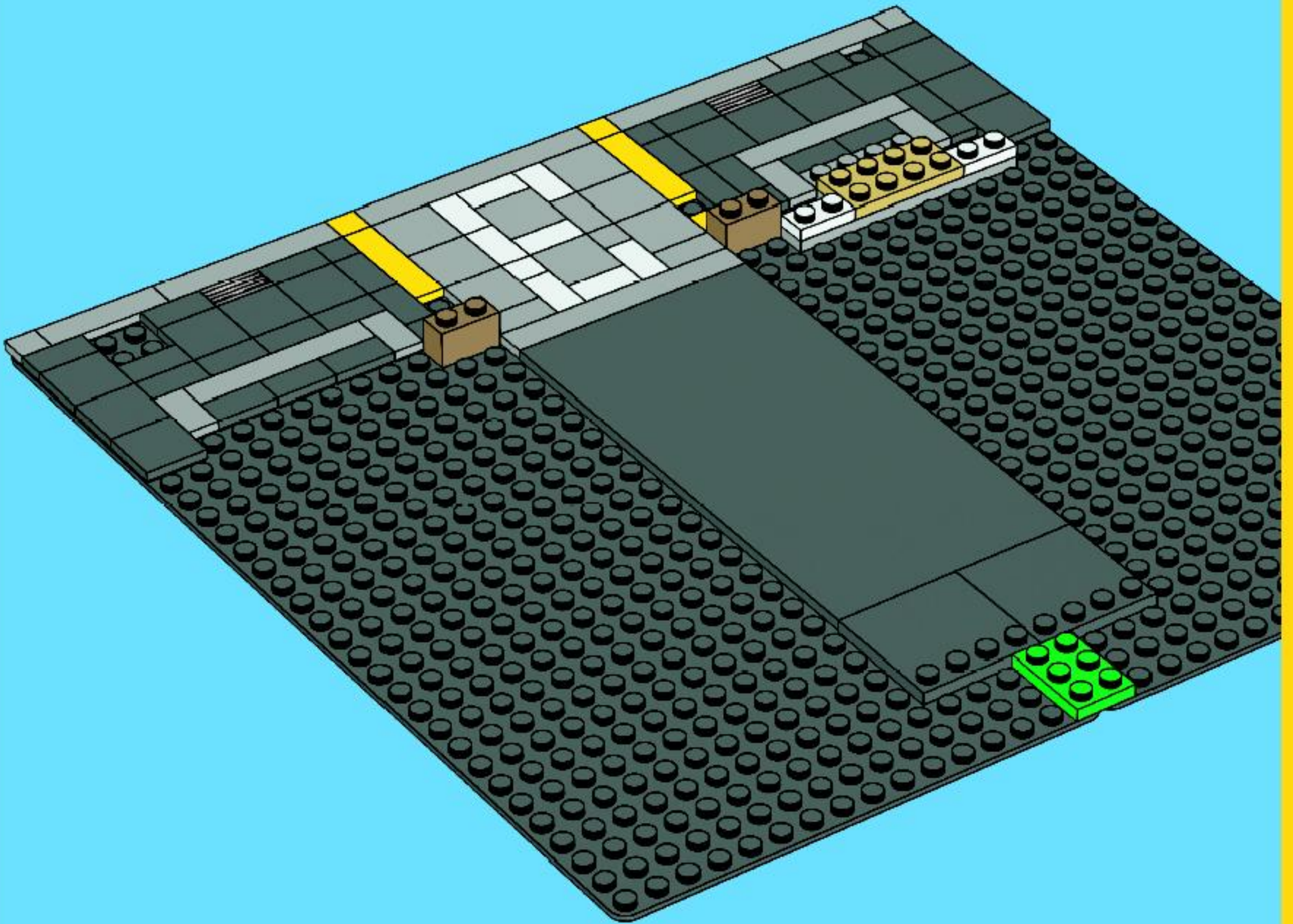

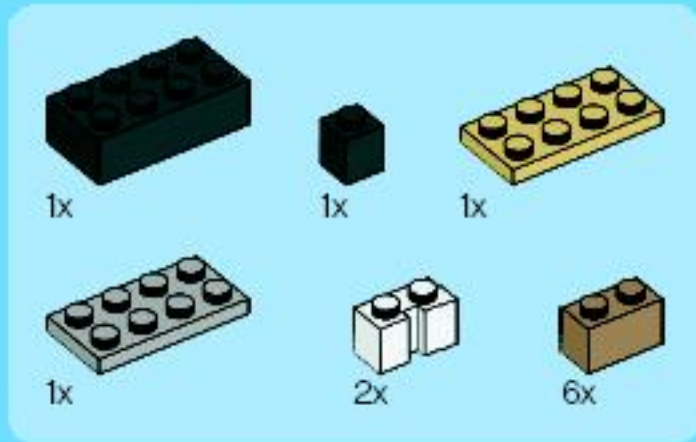

6

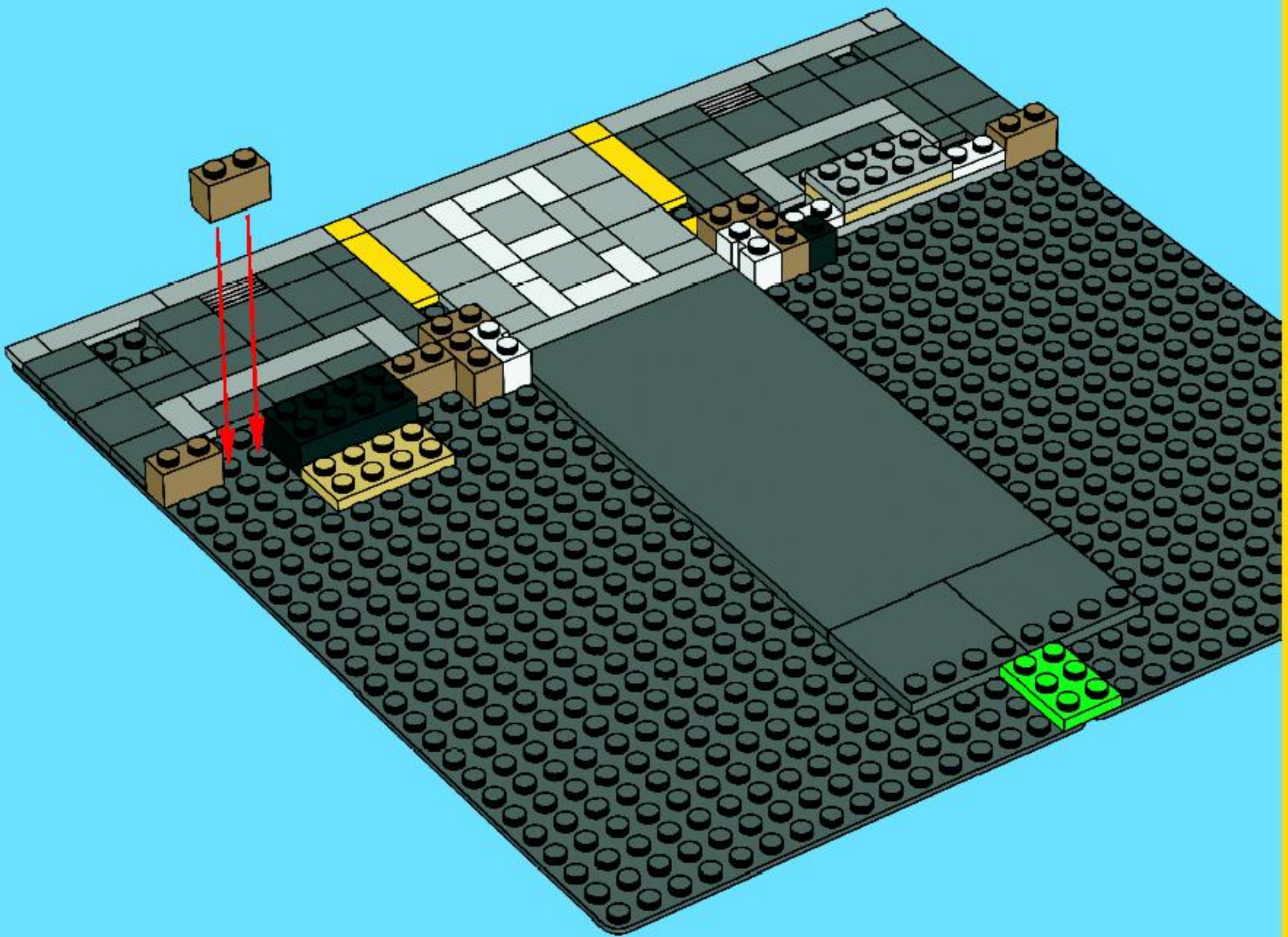

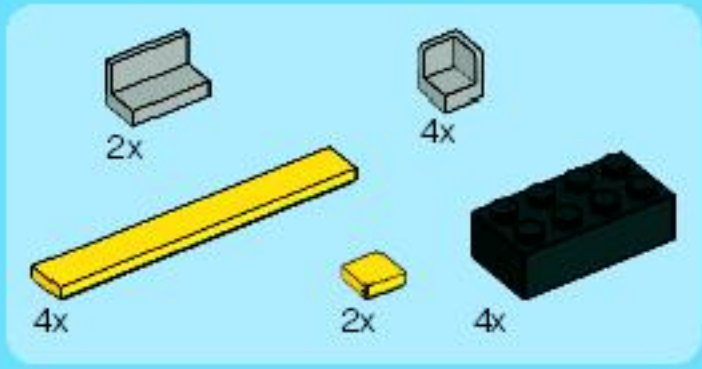

7

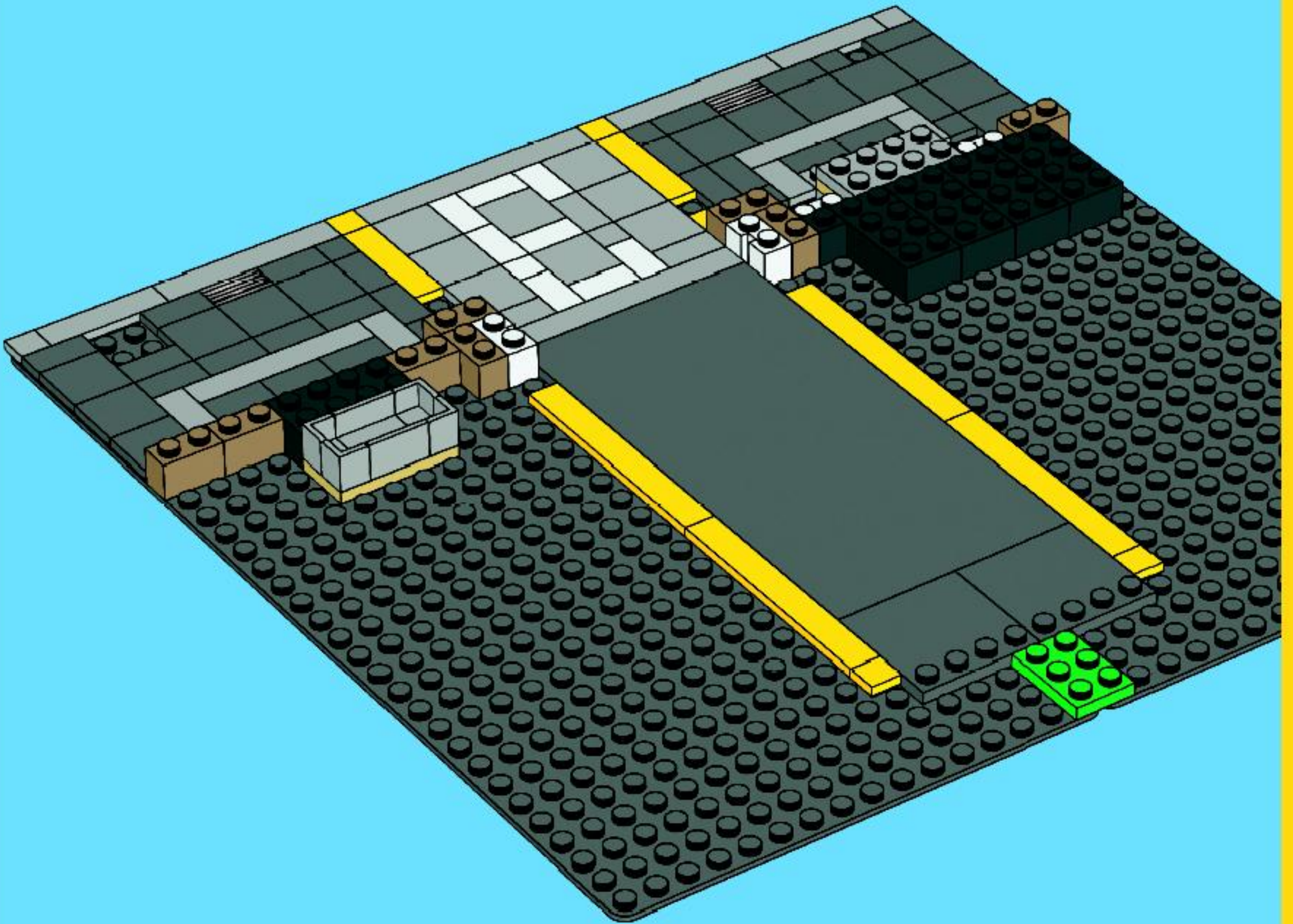

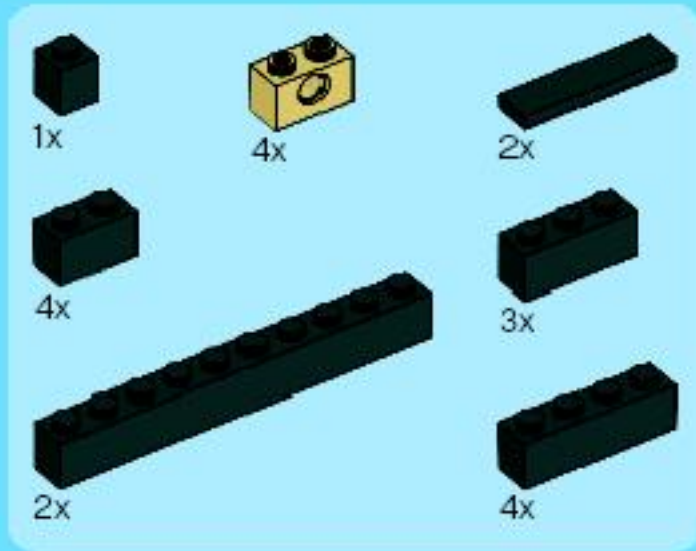

8

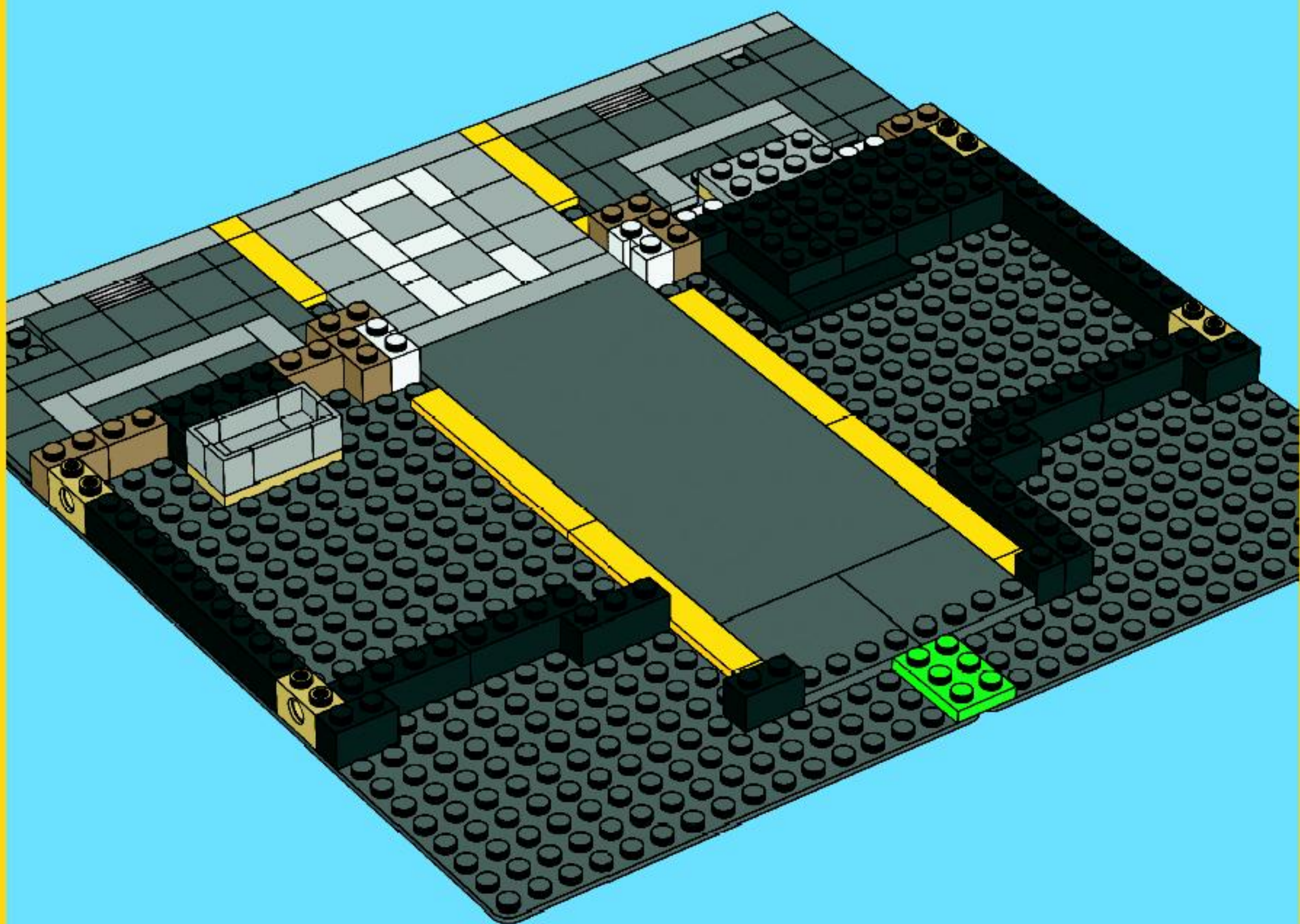

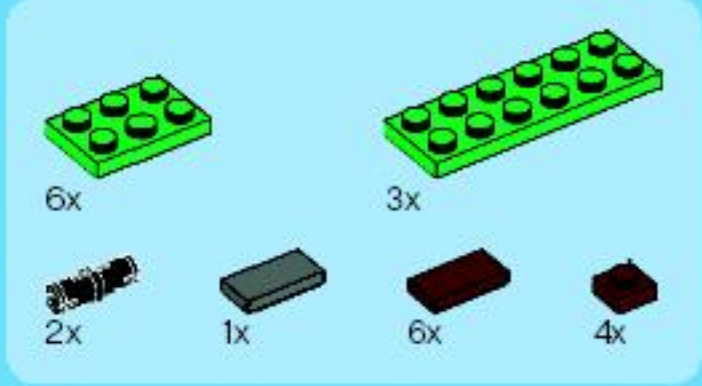

9

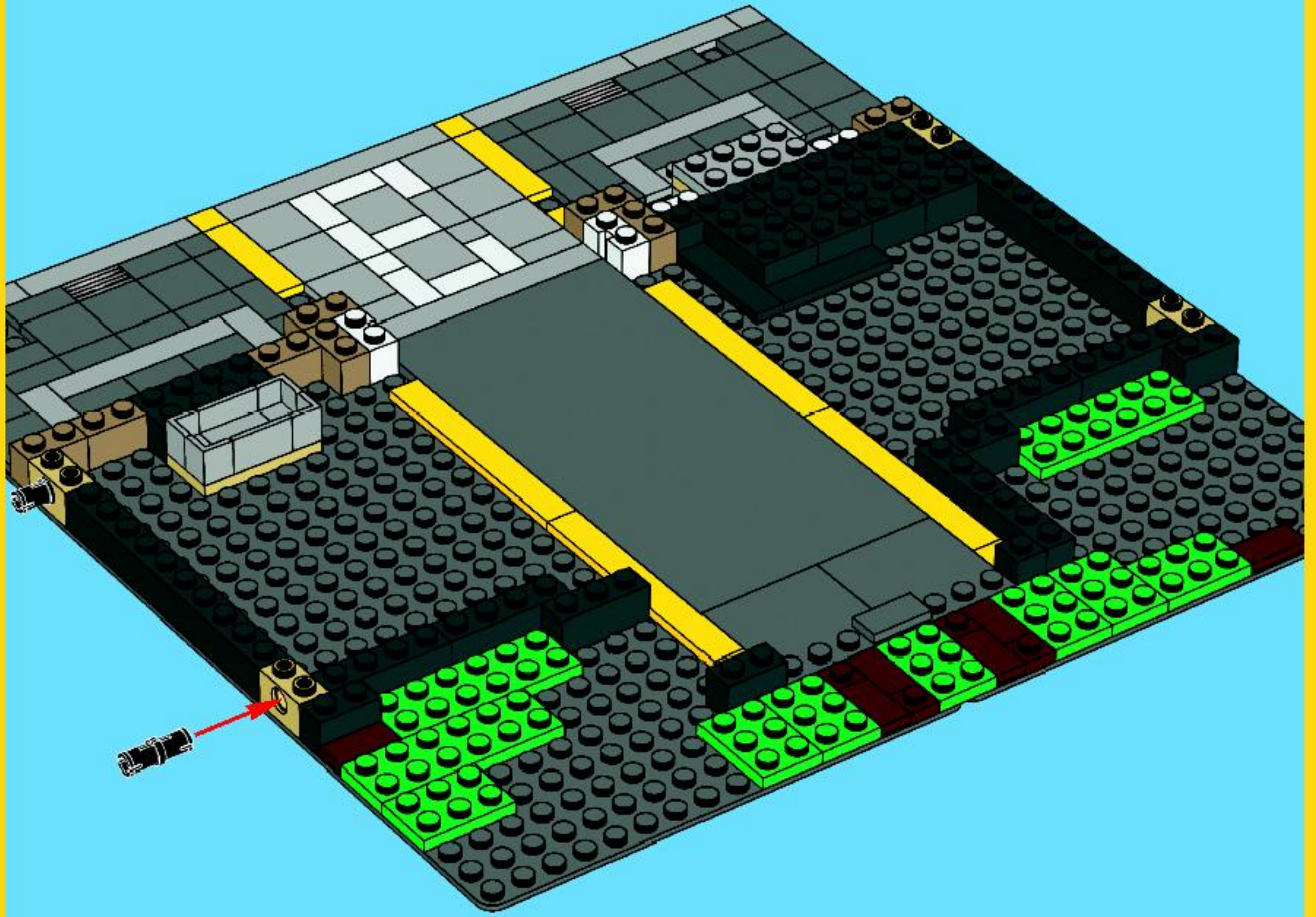

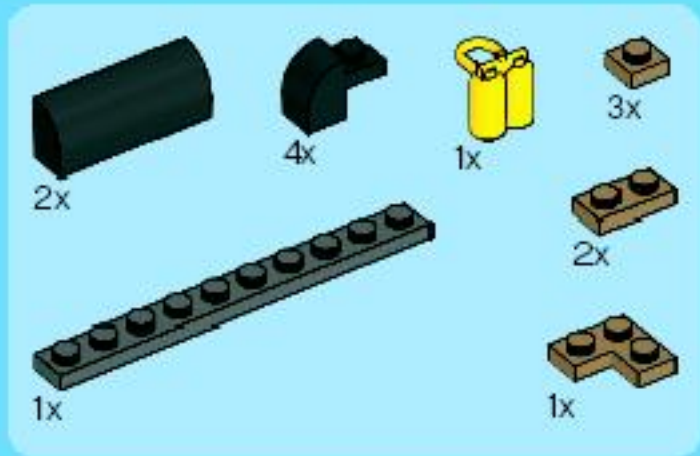

10

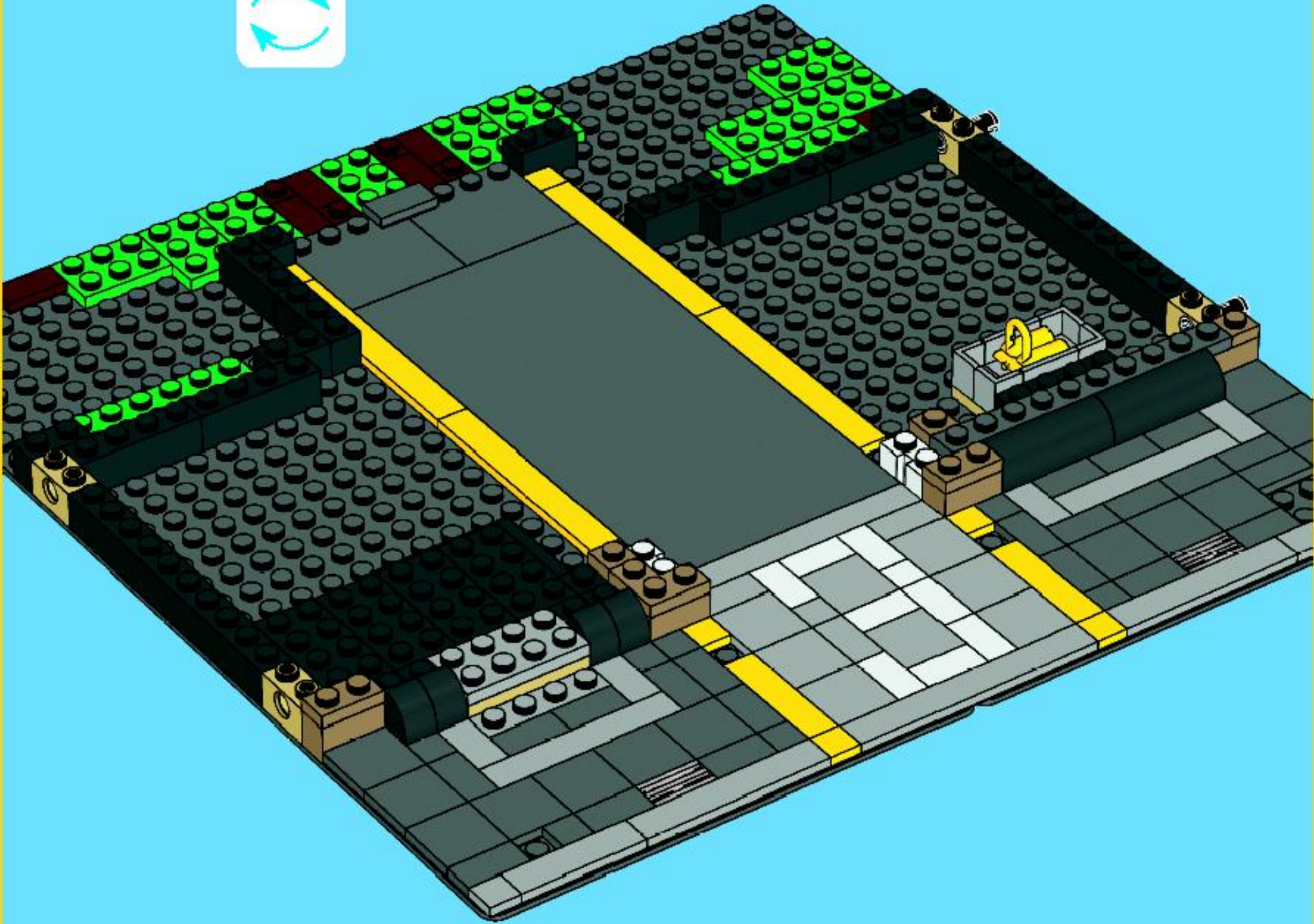

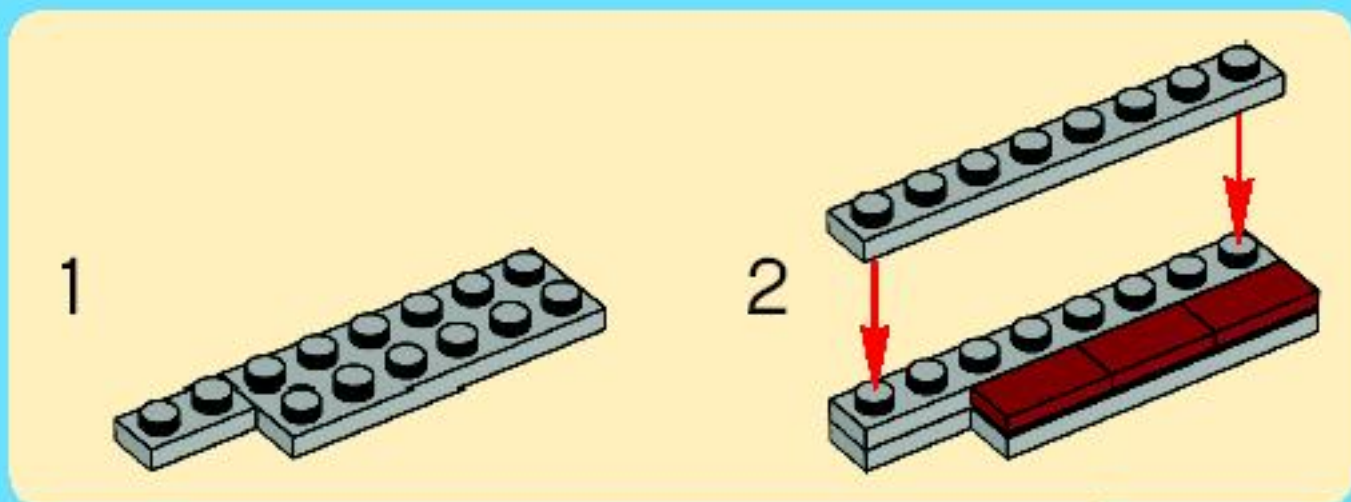
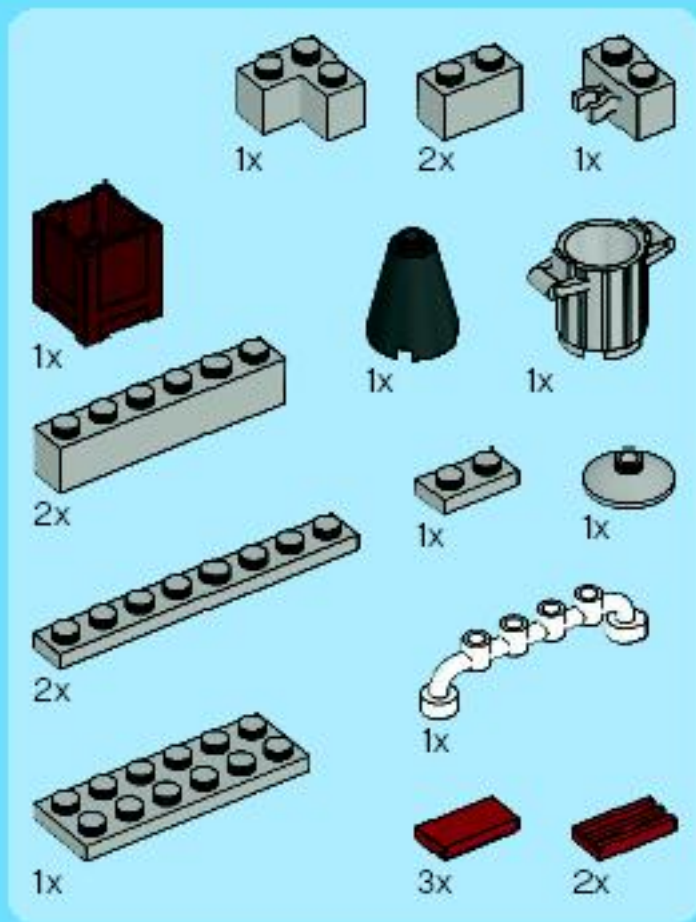

12

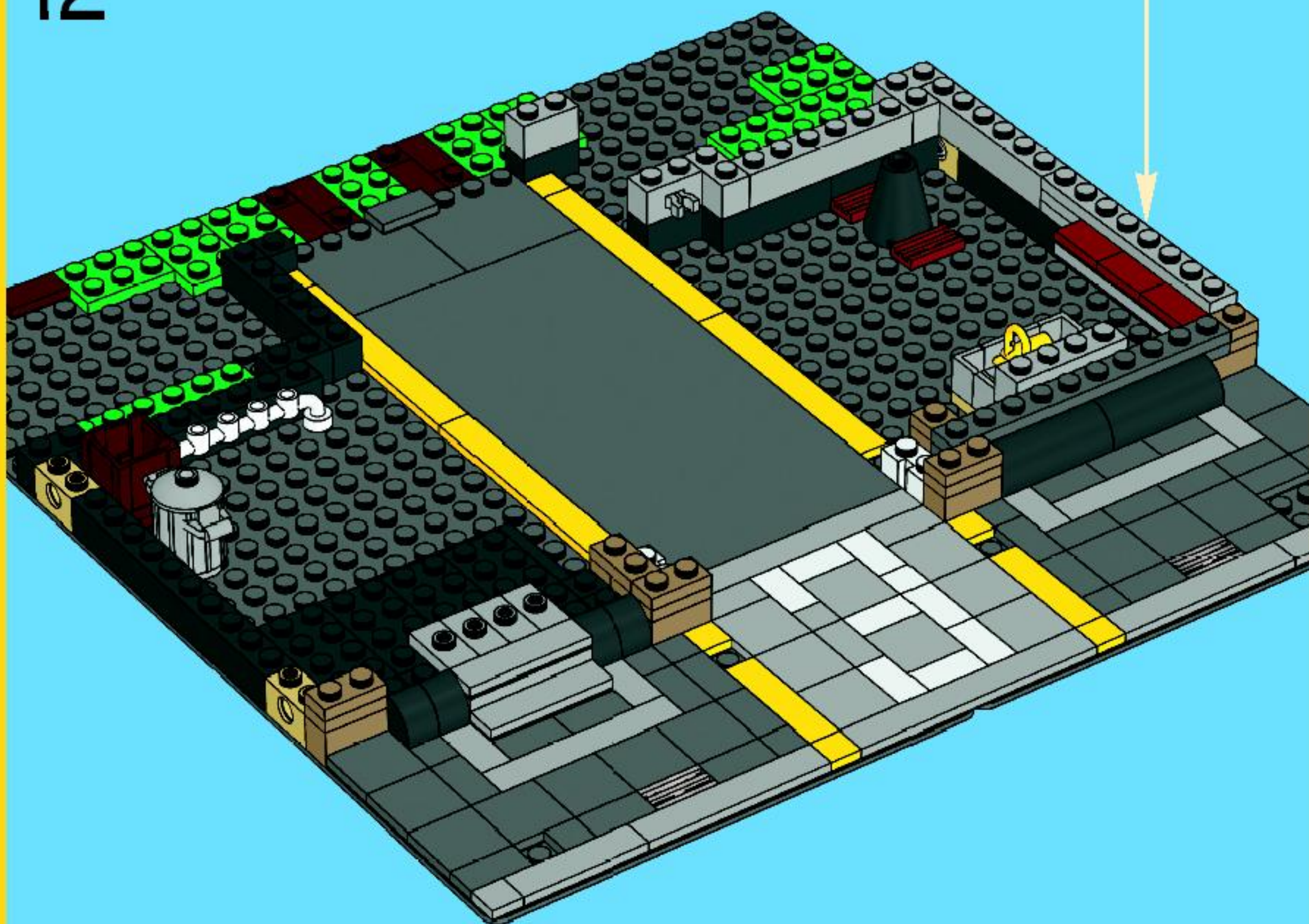

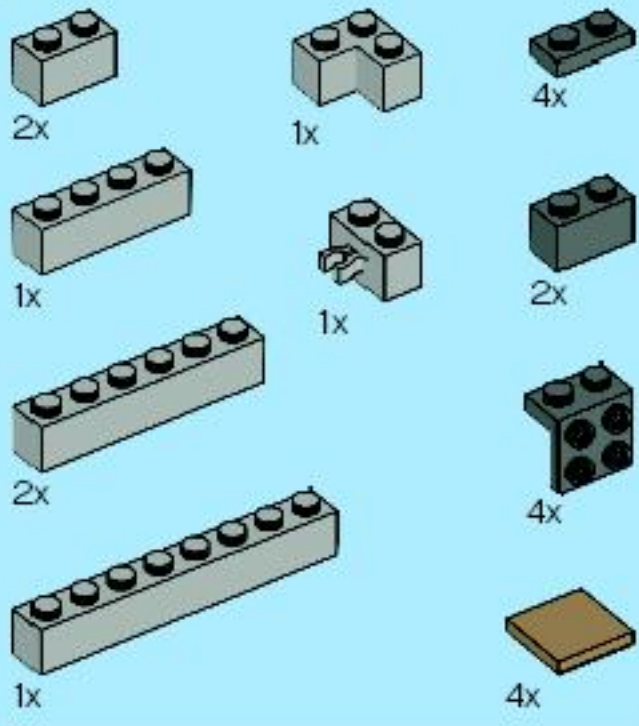

13

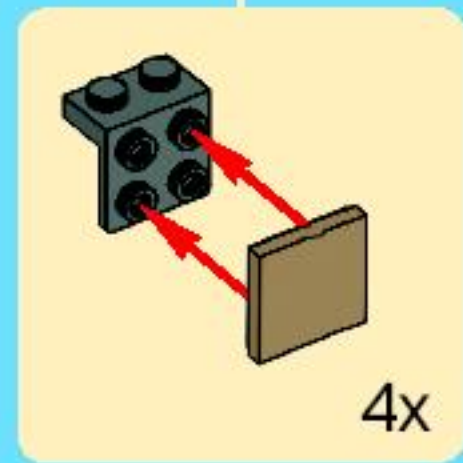
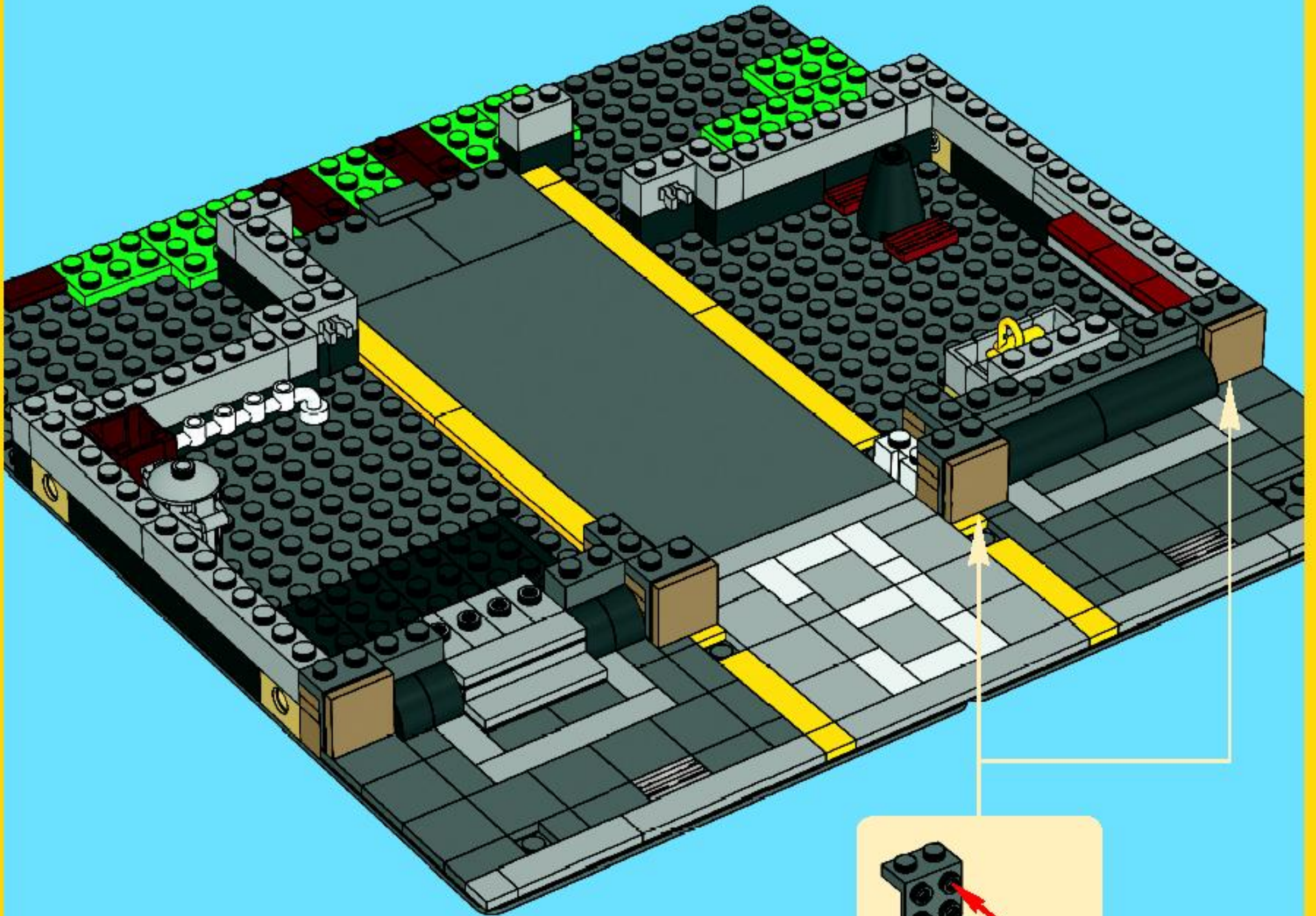

- 8x 
- 4x 
- 4x 
- 2x 
- 2x 
- 10x 

14

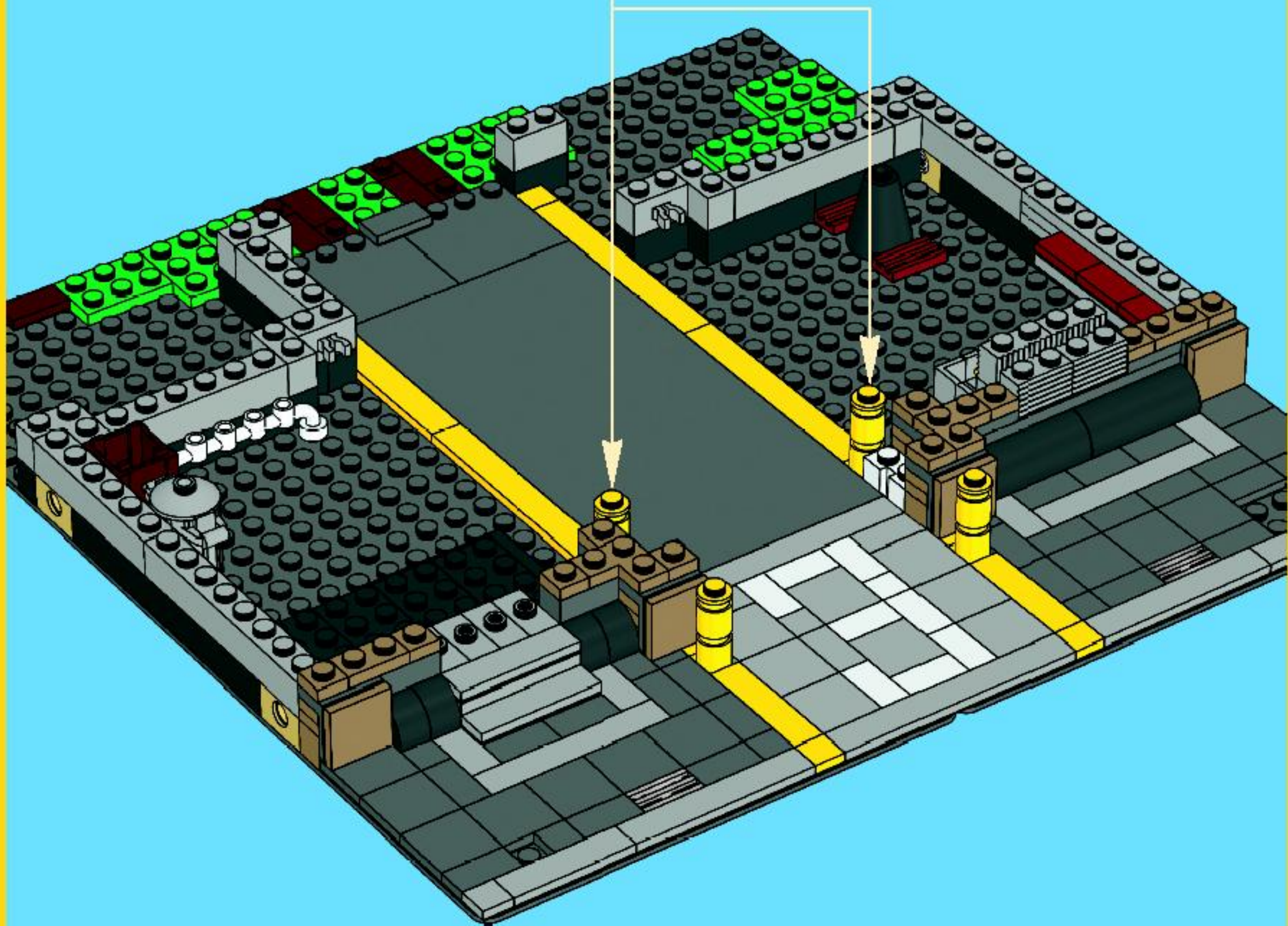
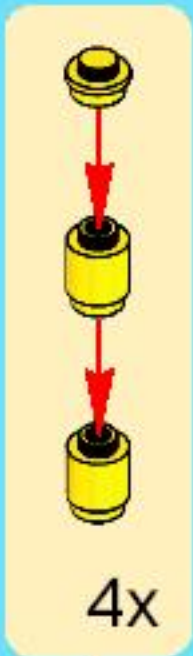

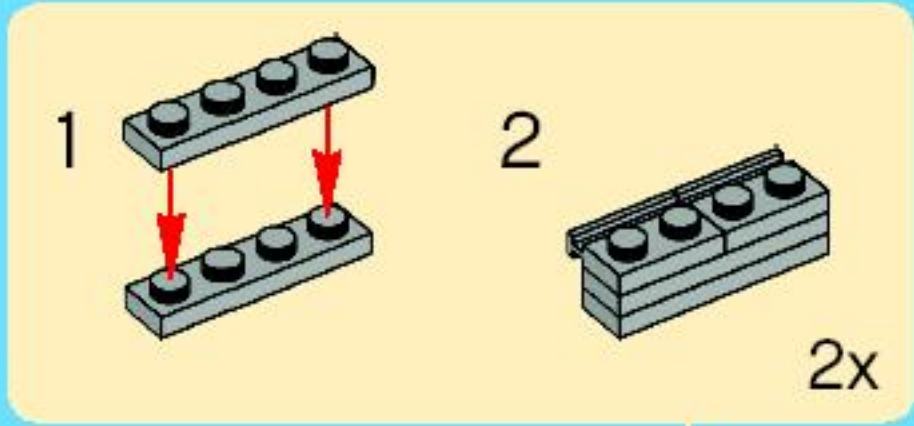
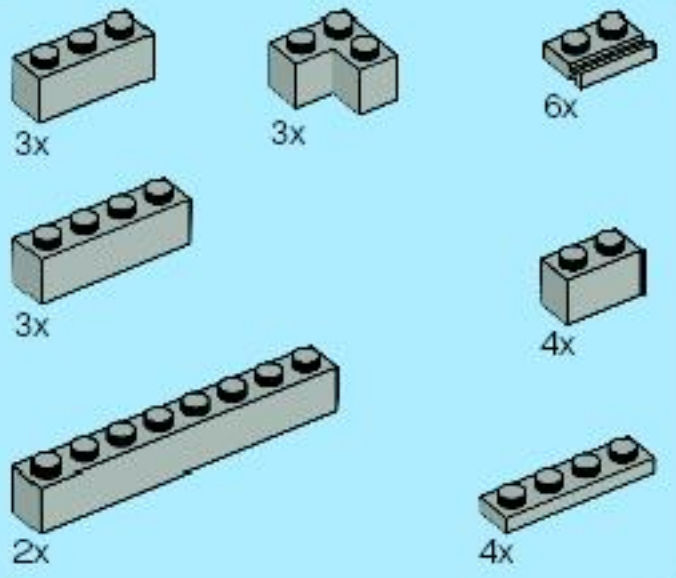

15

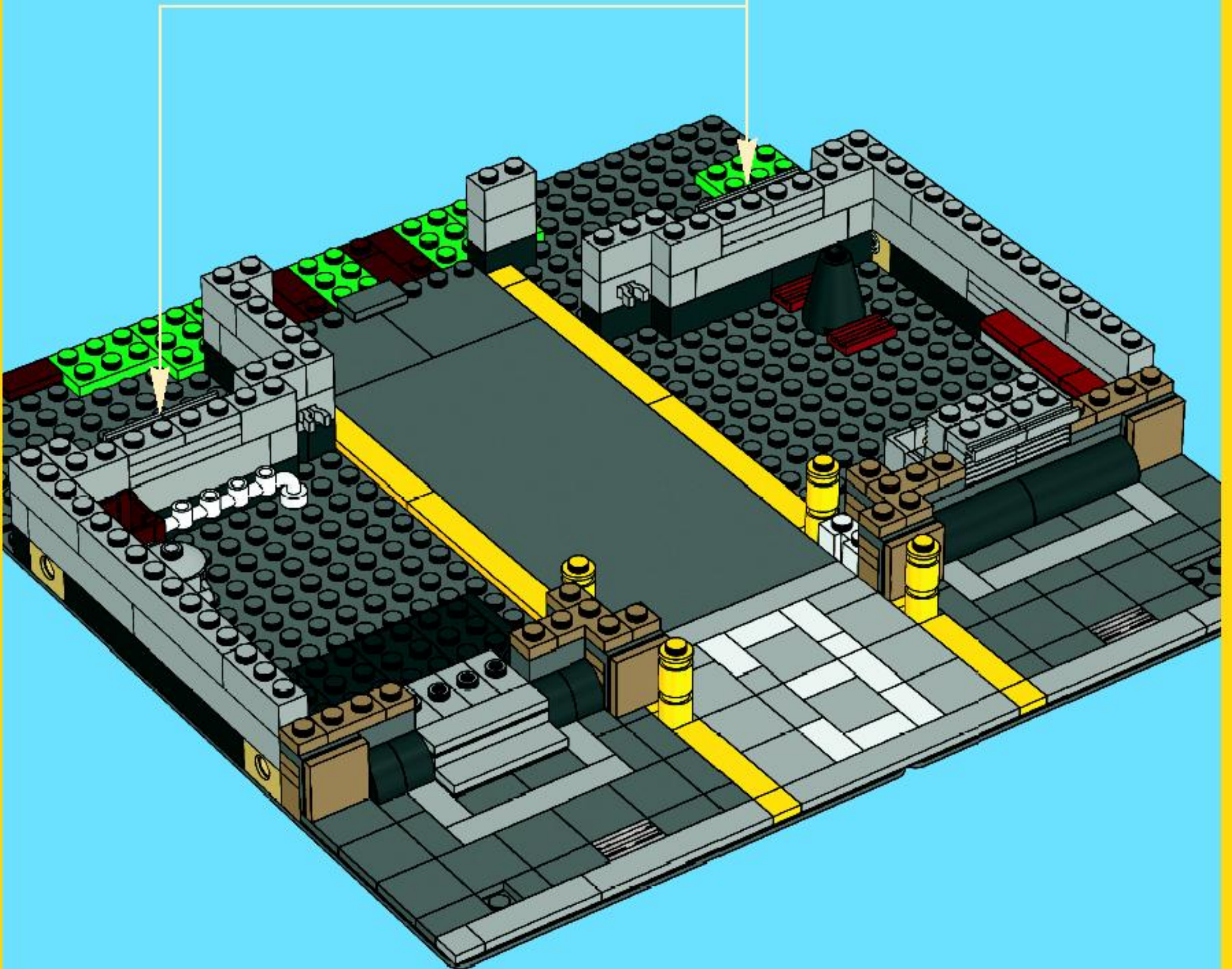

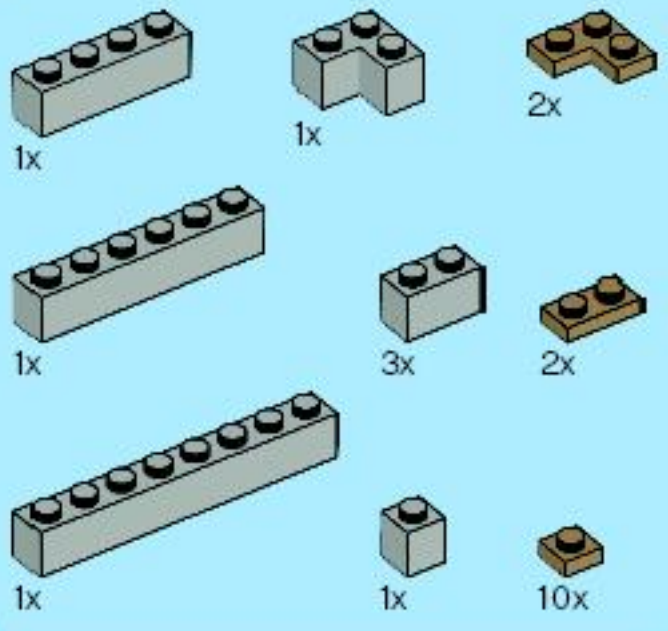

17

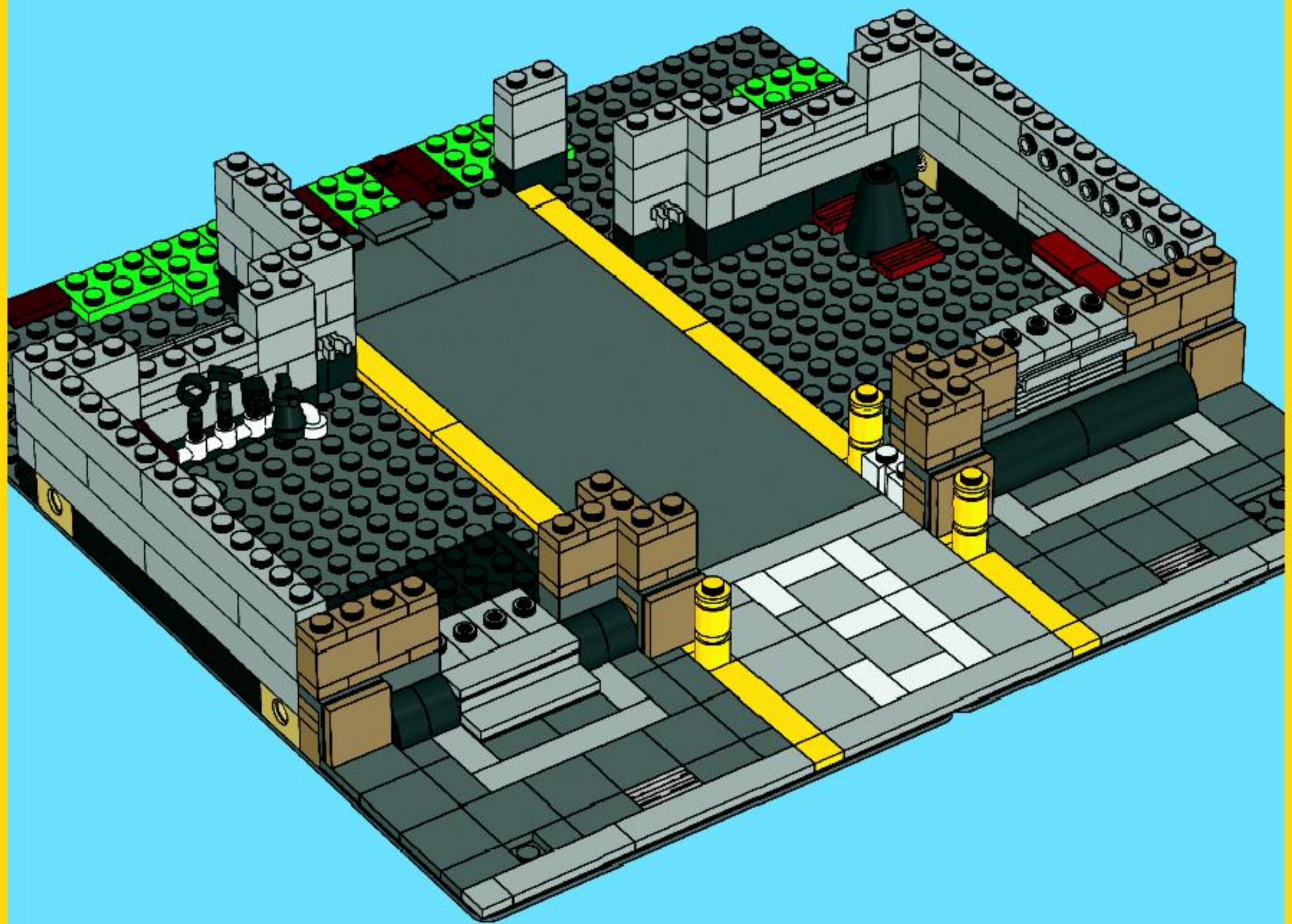

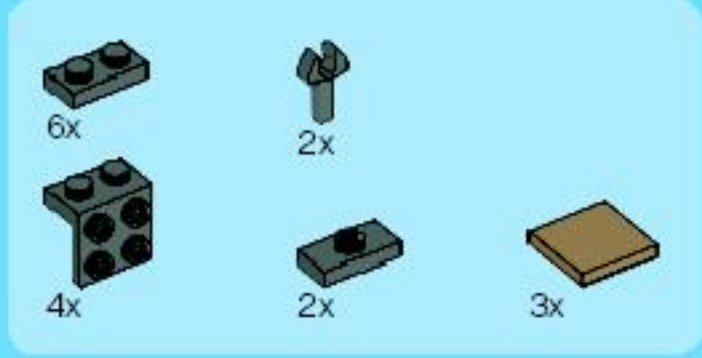

18

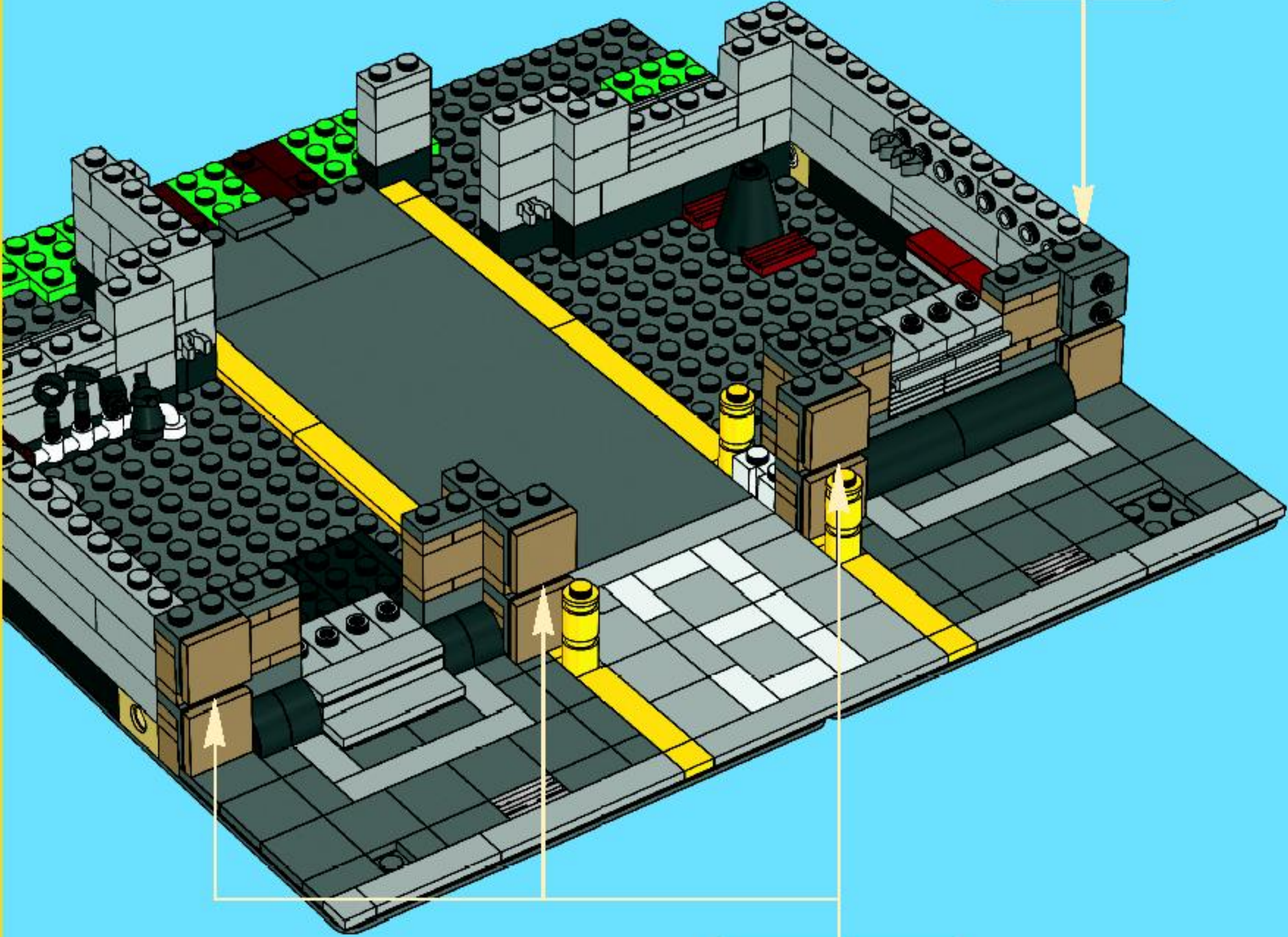
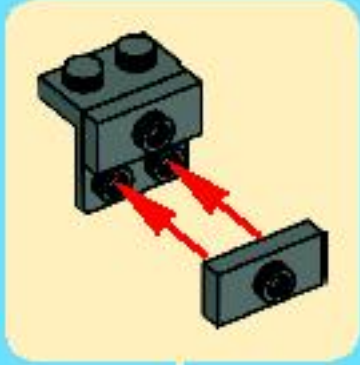

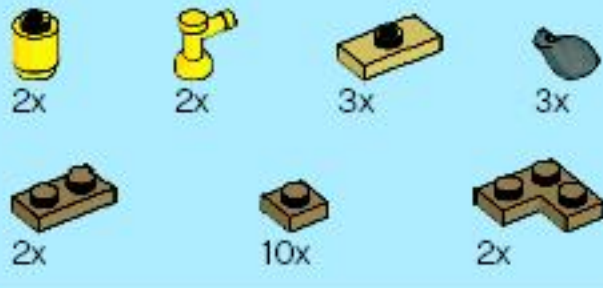

19

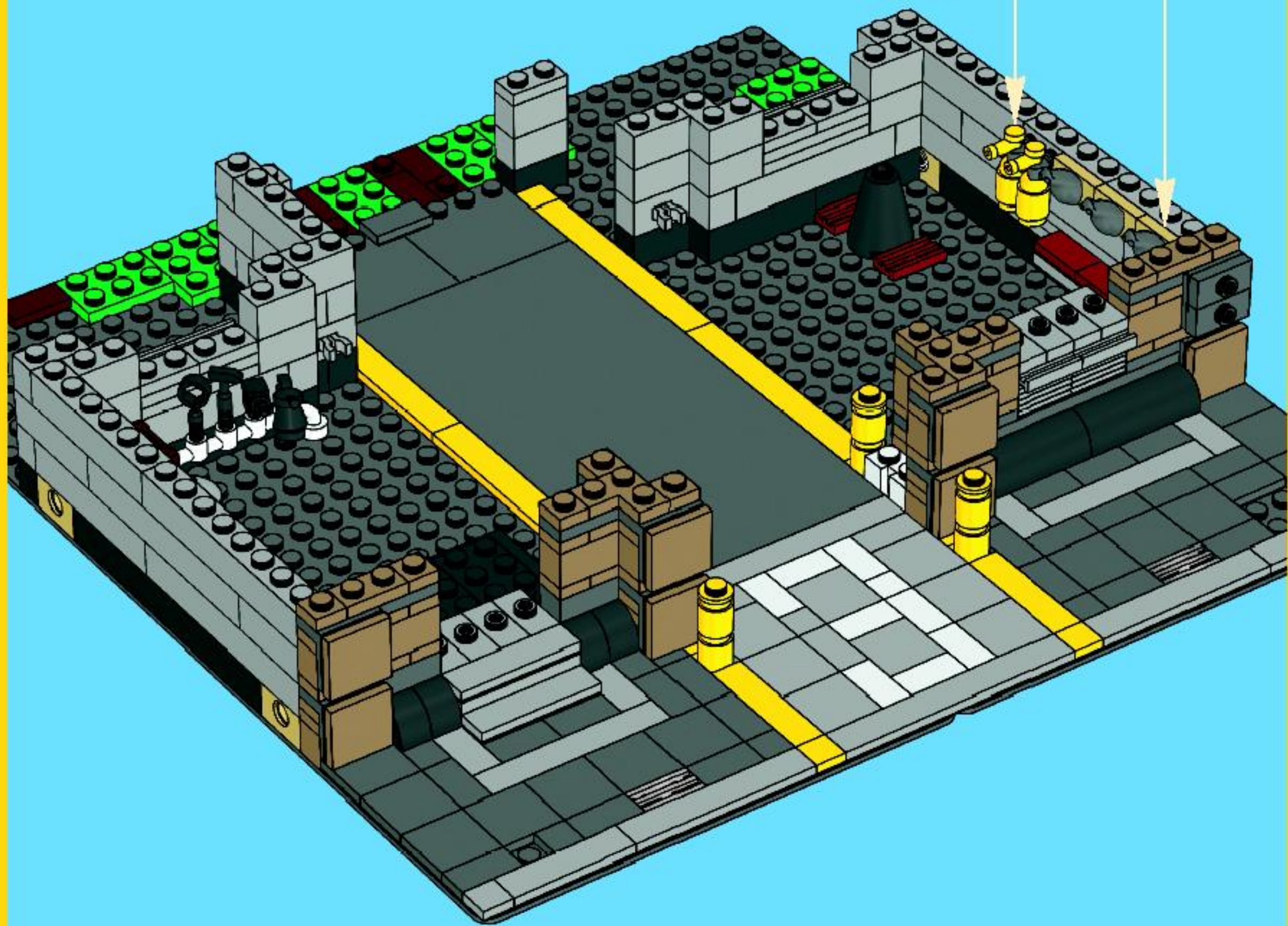
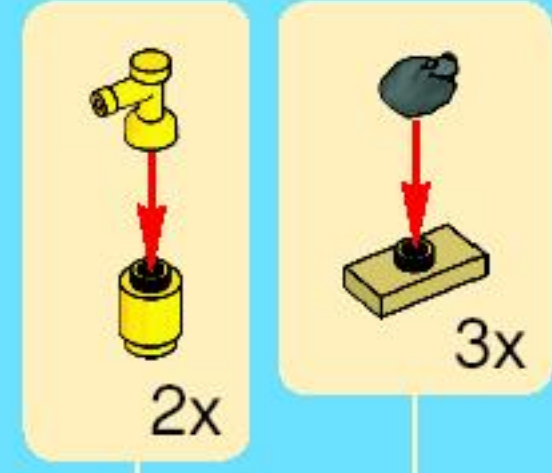

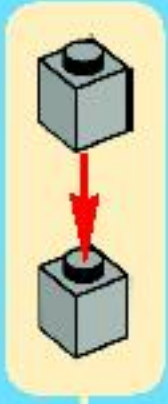
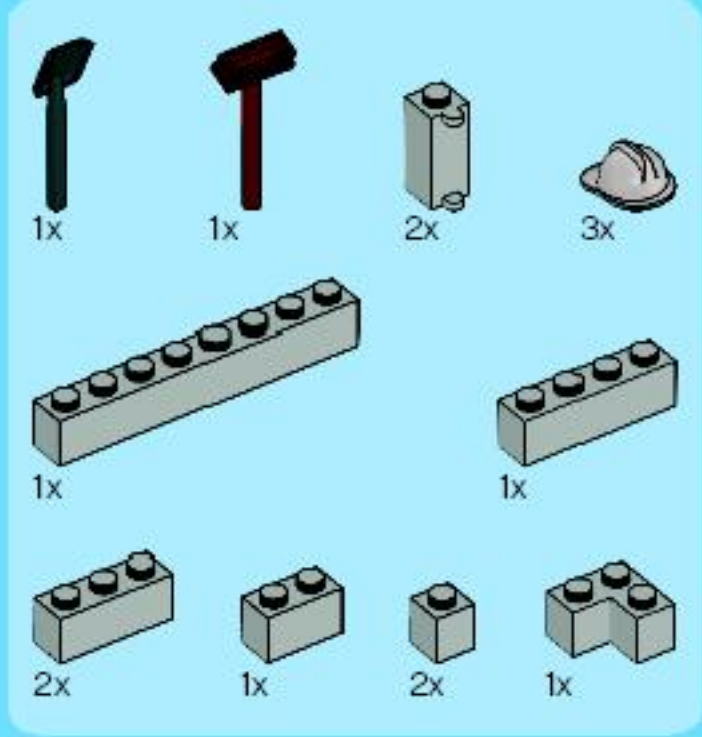

20

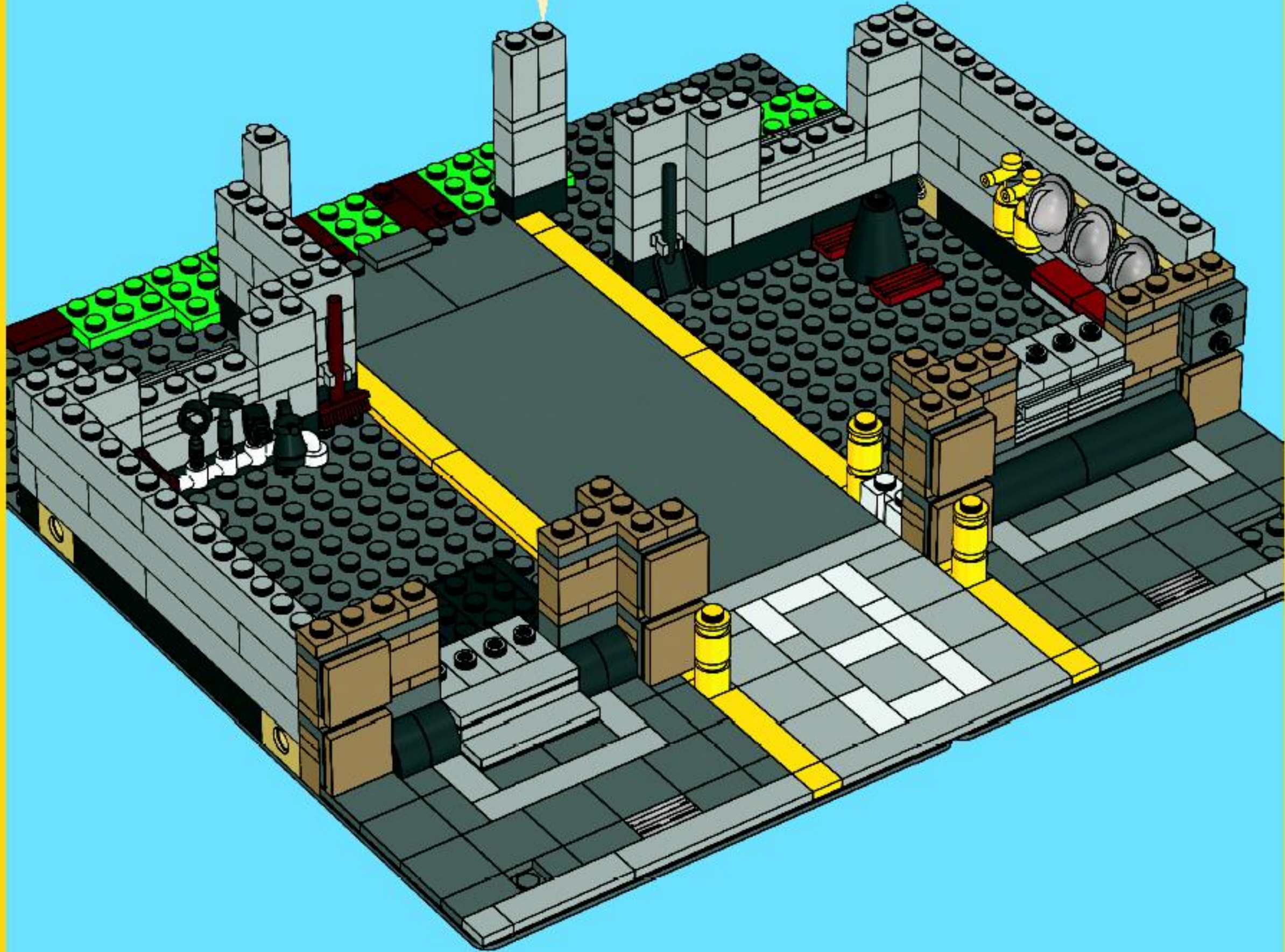

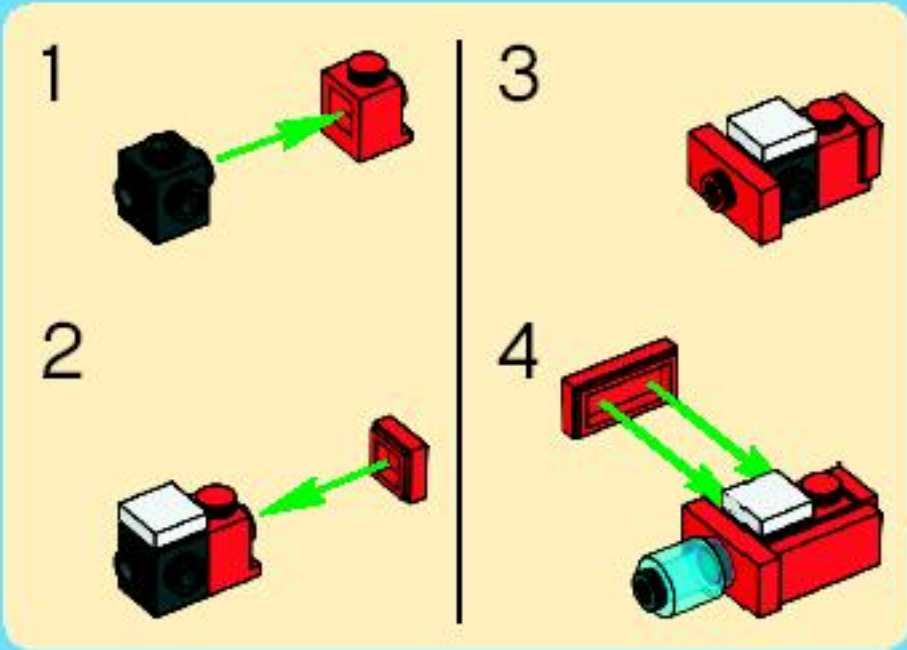
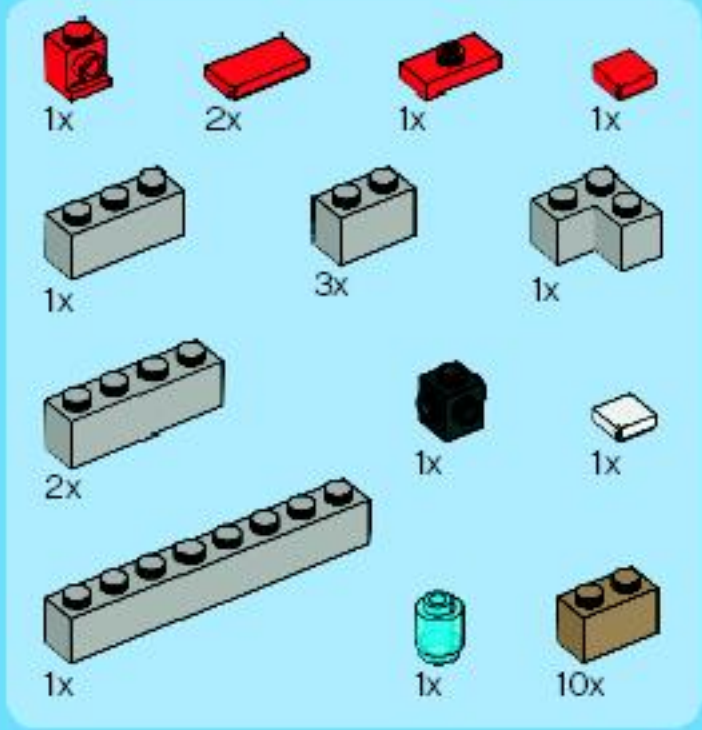

21

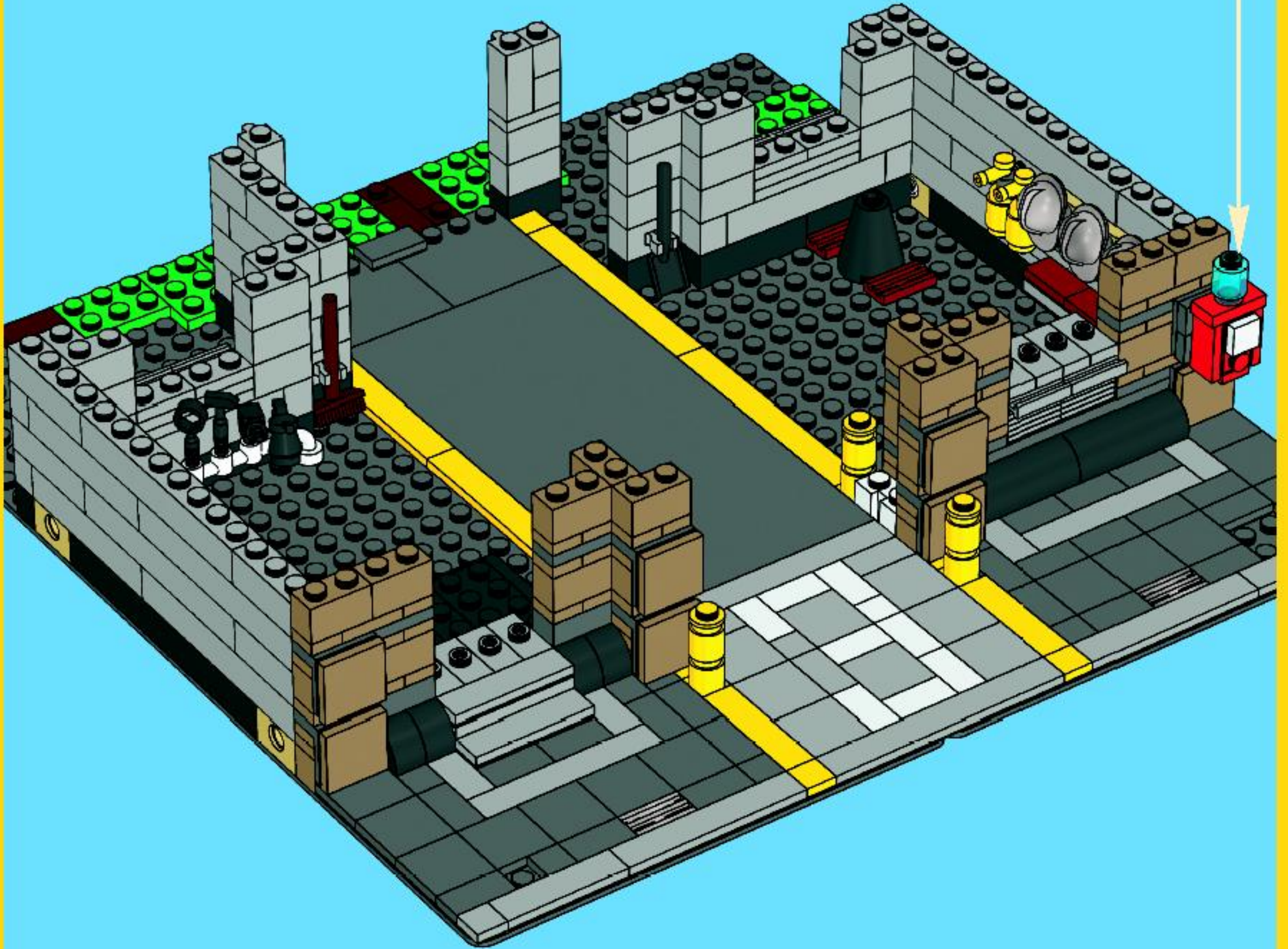

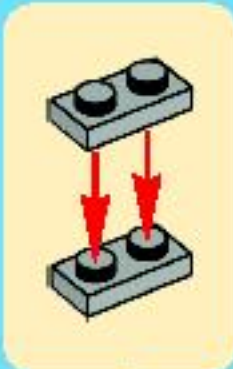
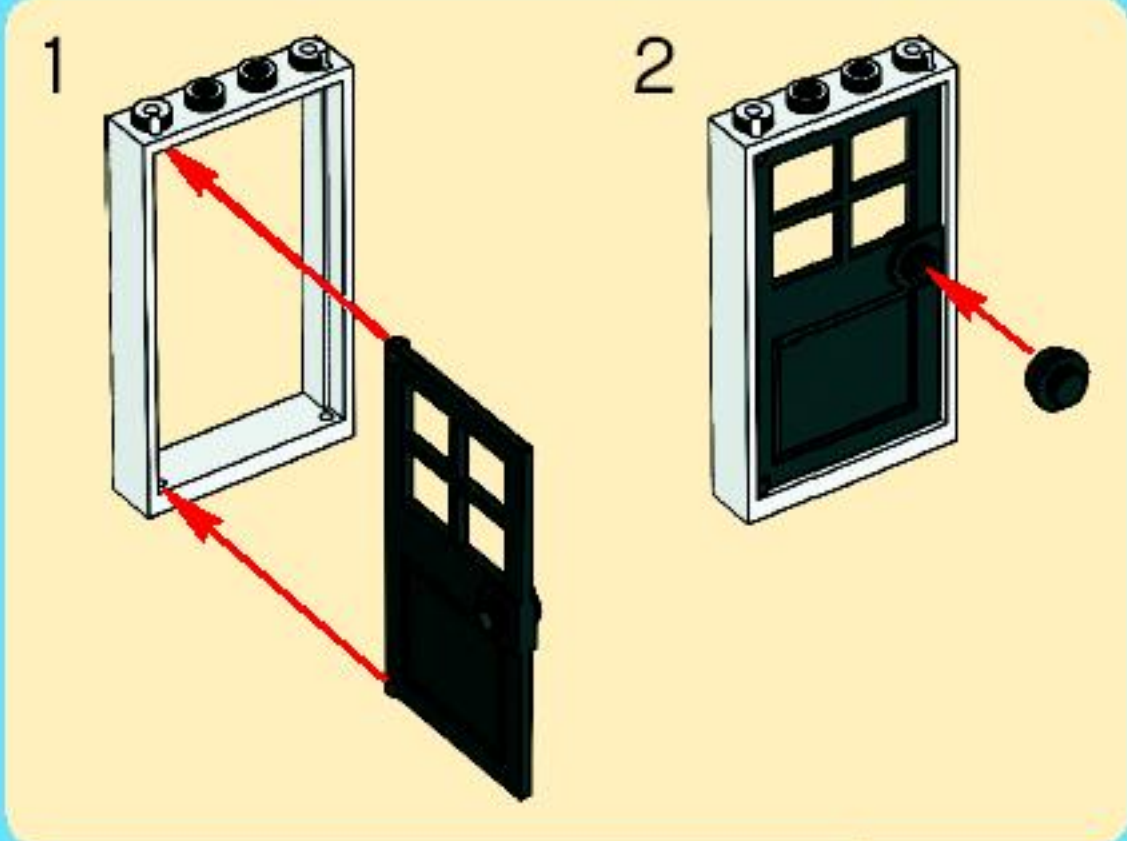
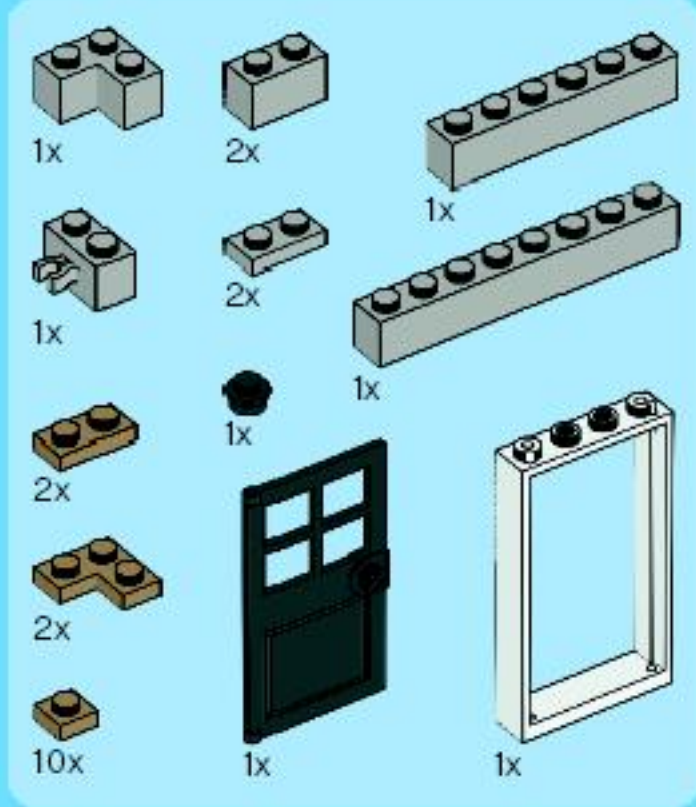

22

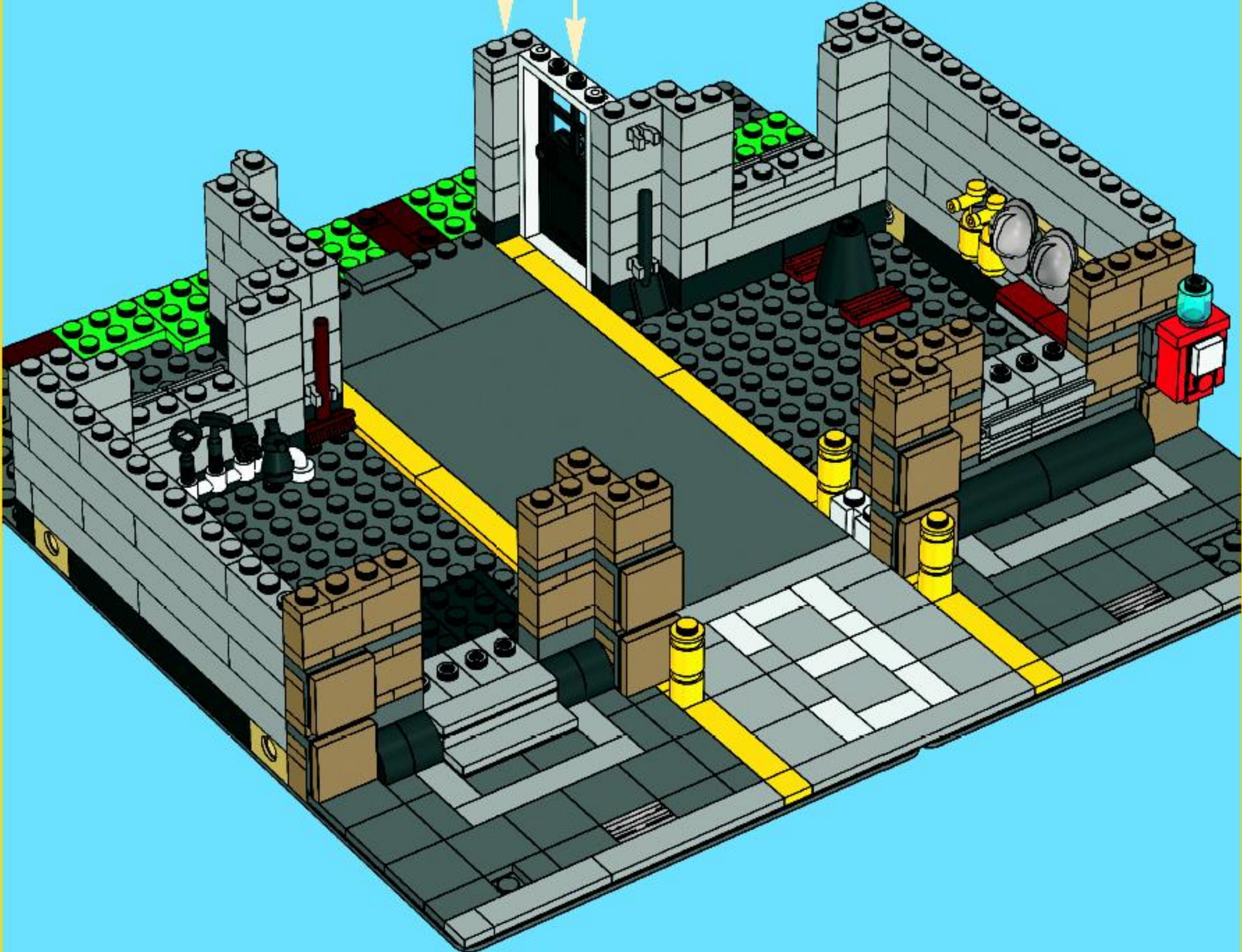

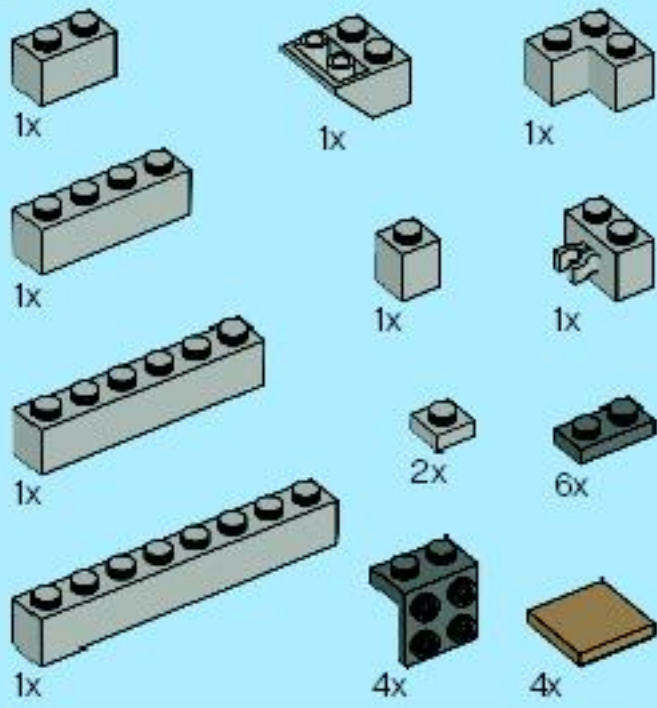

23

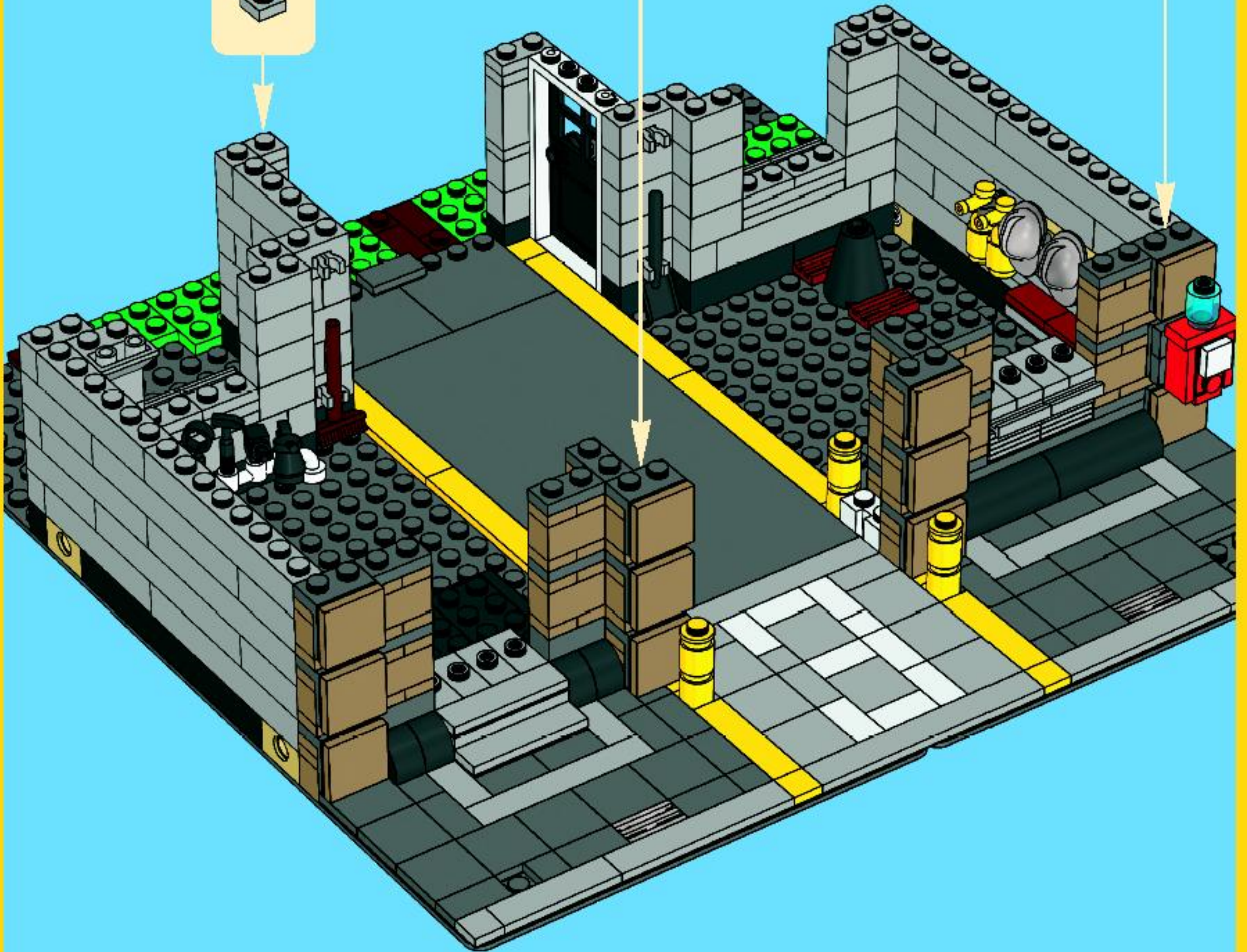
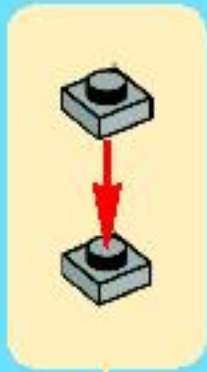
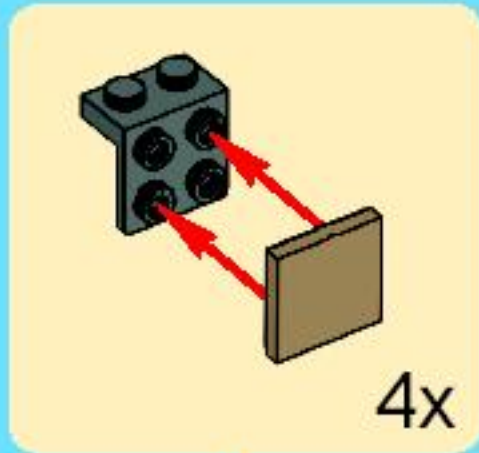



16x



8x



6x

24

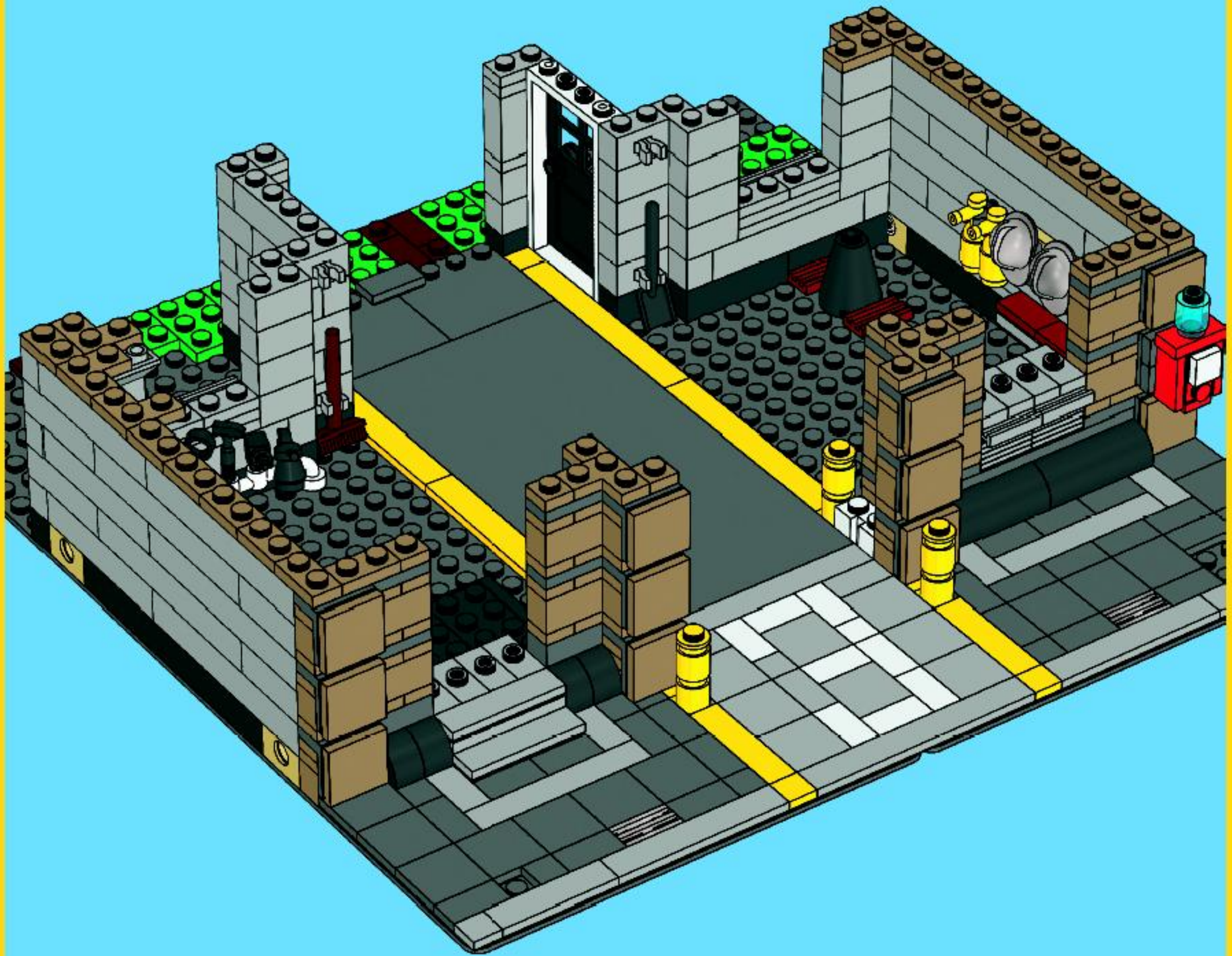

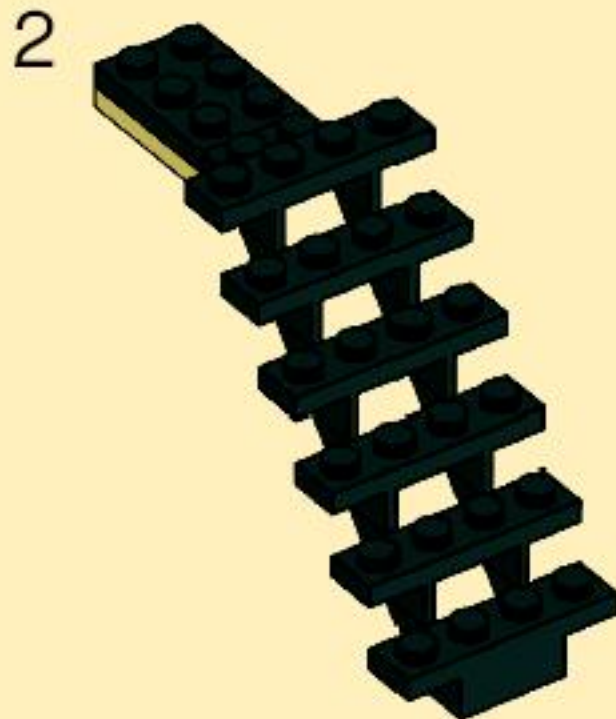
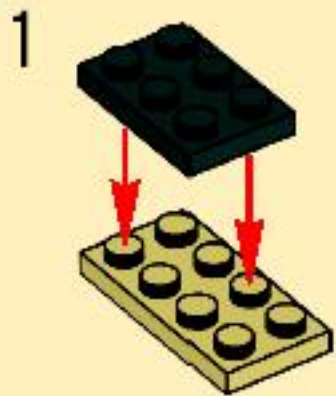
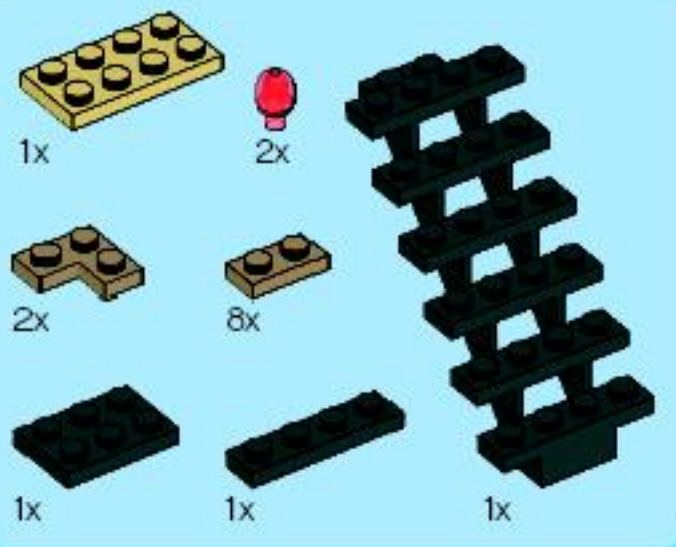

25

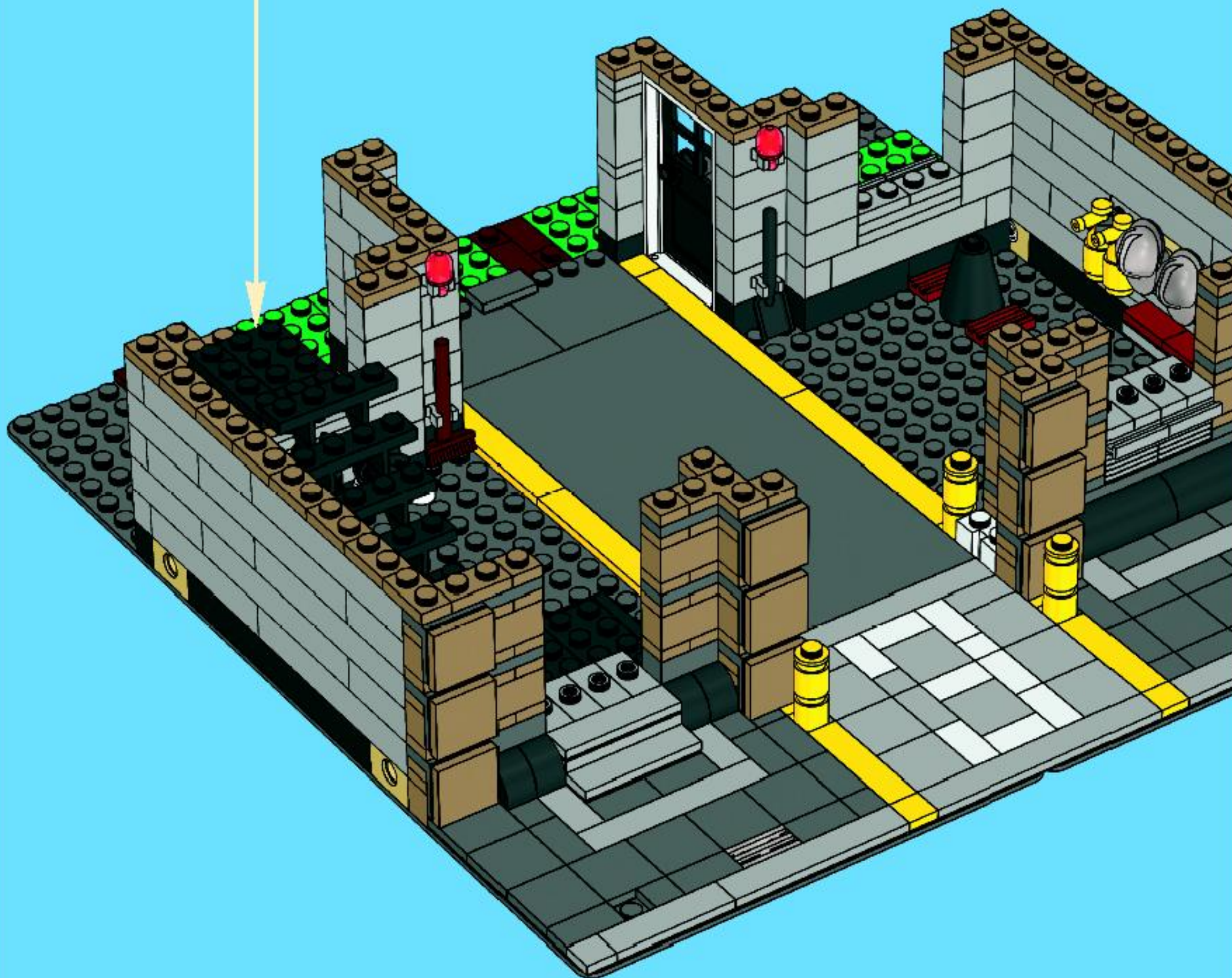

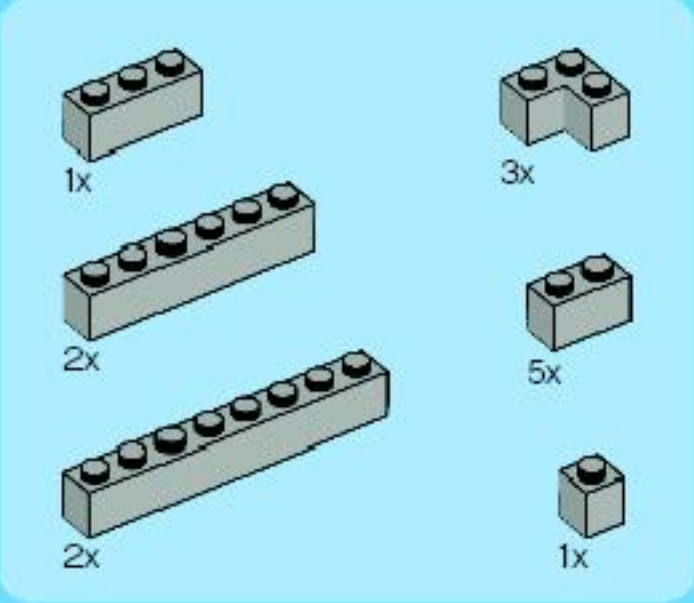

26

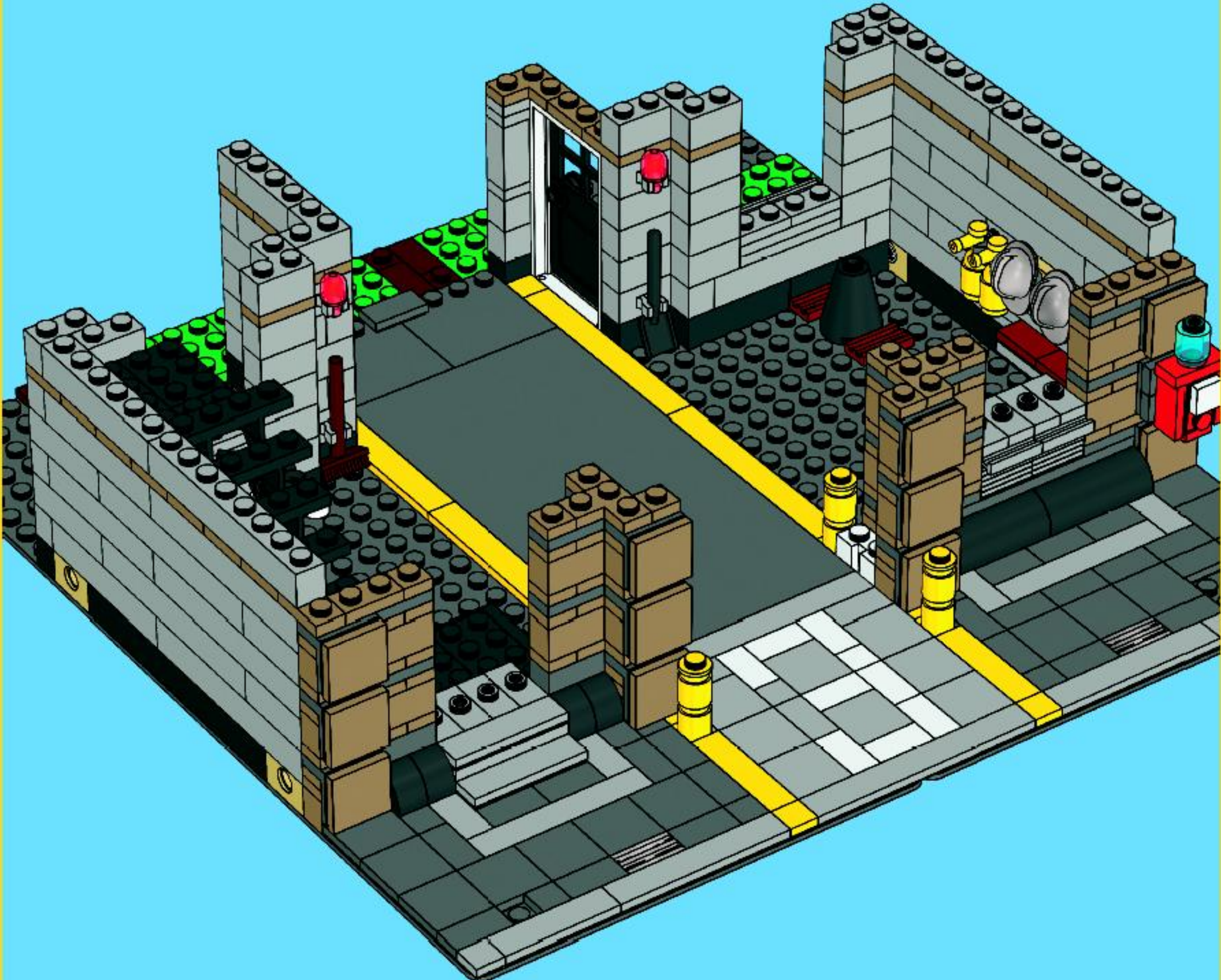



2x



10x

27

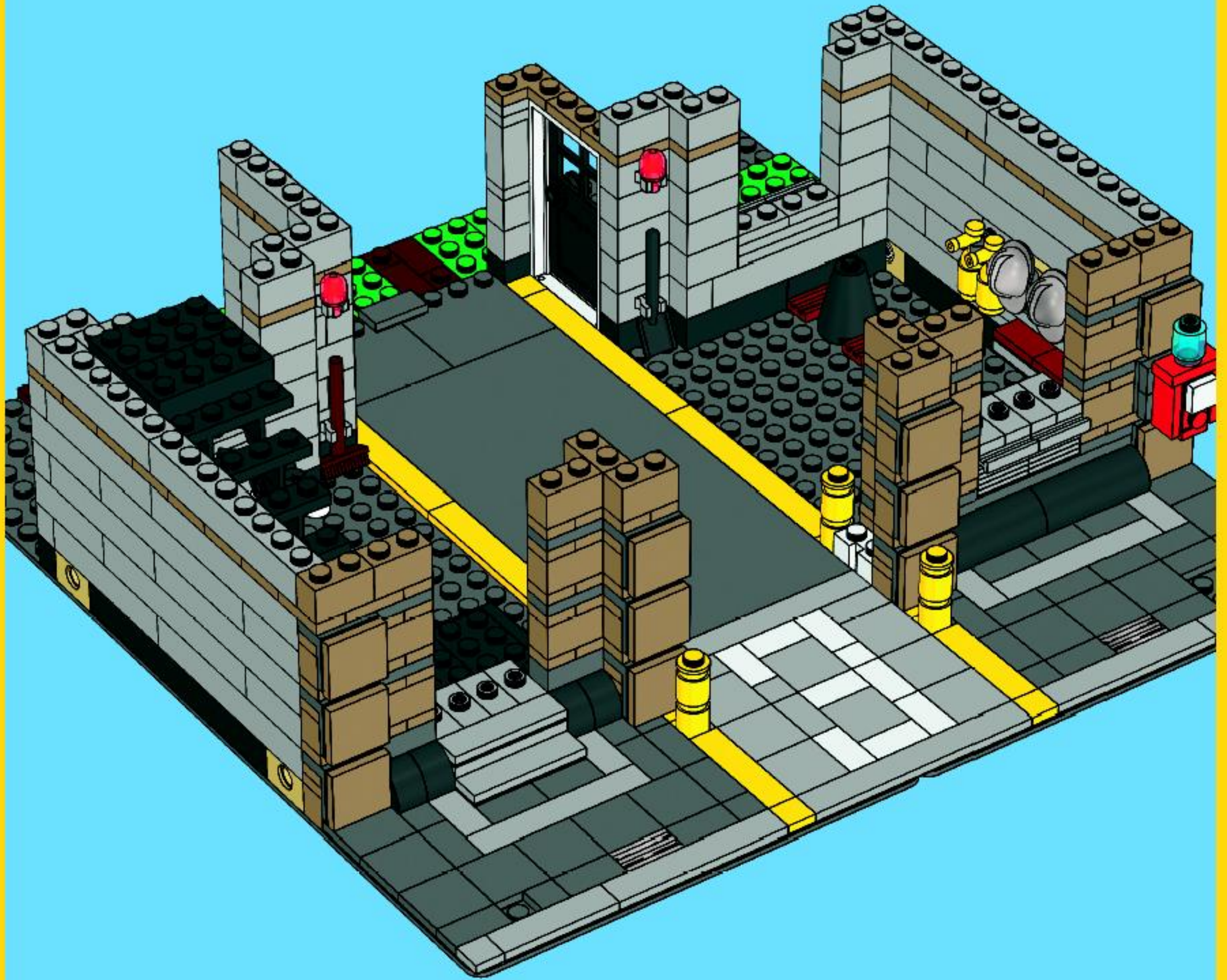

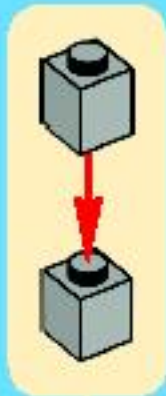
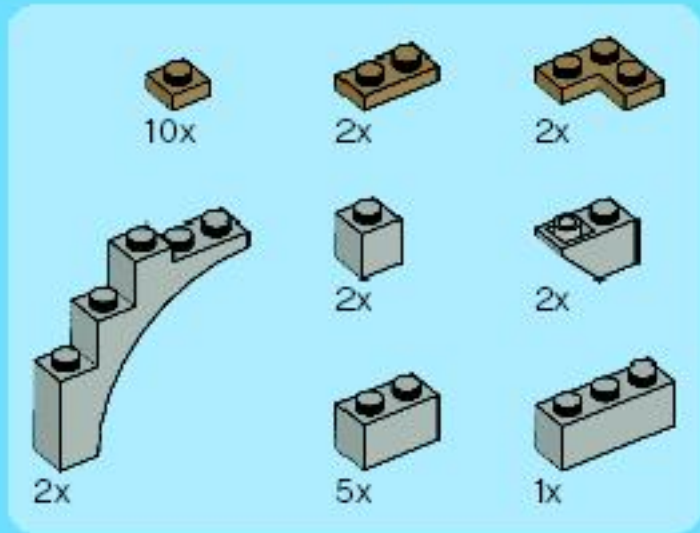

28

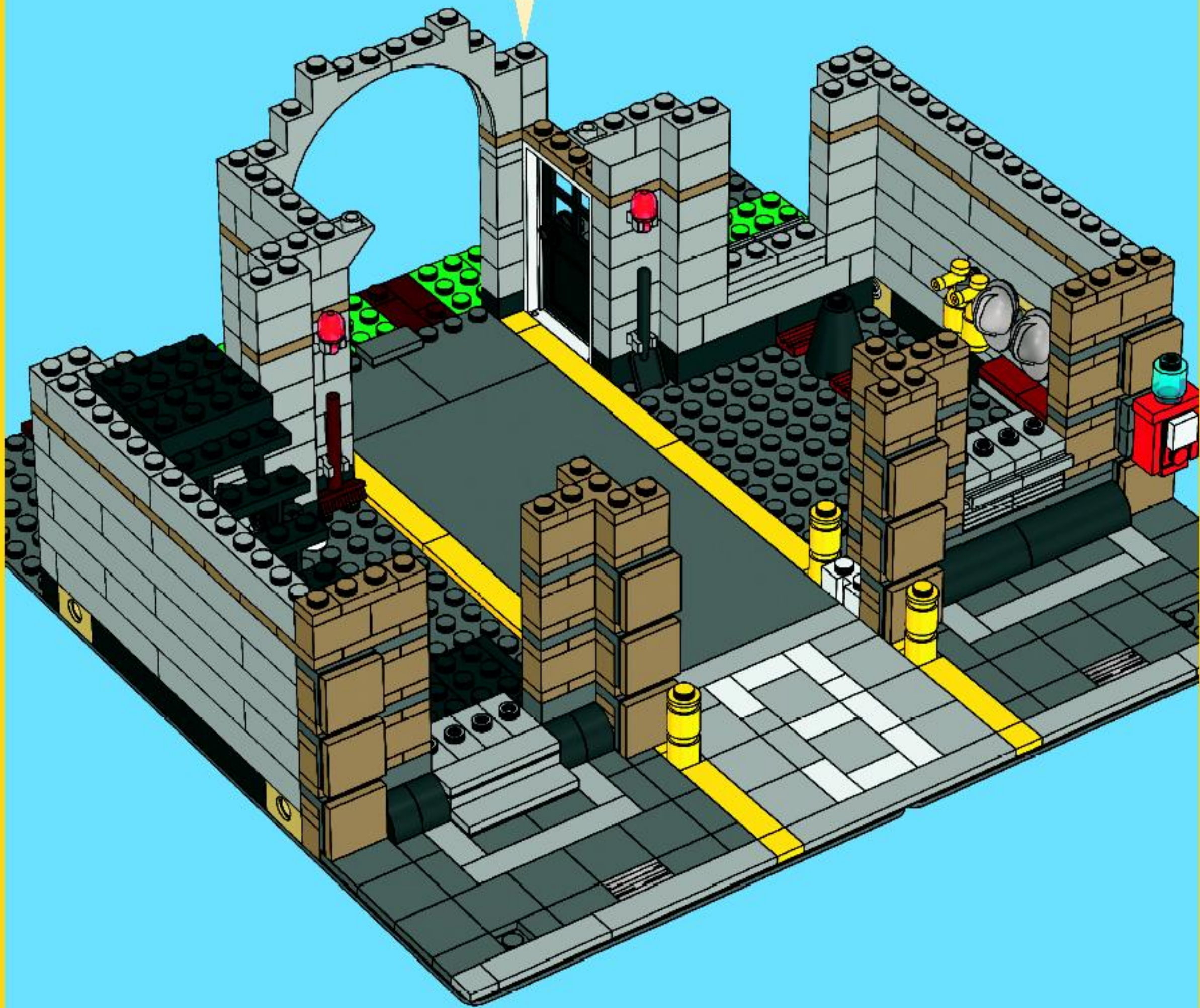

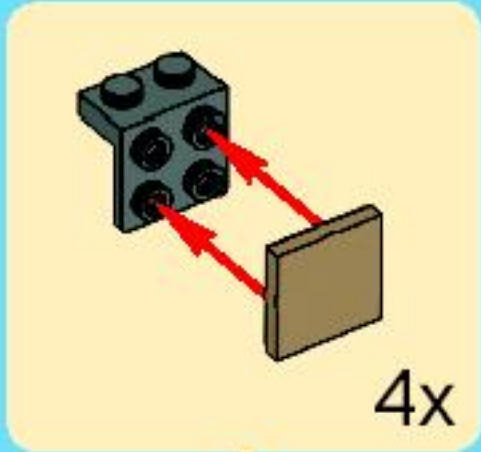
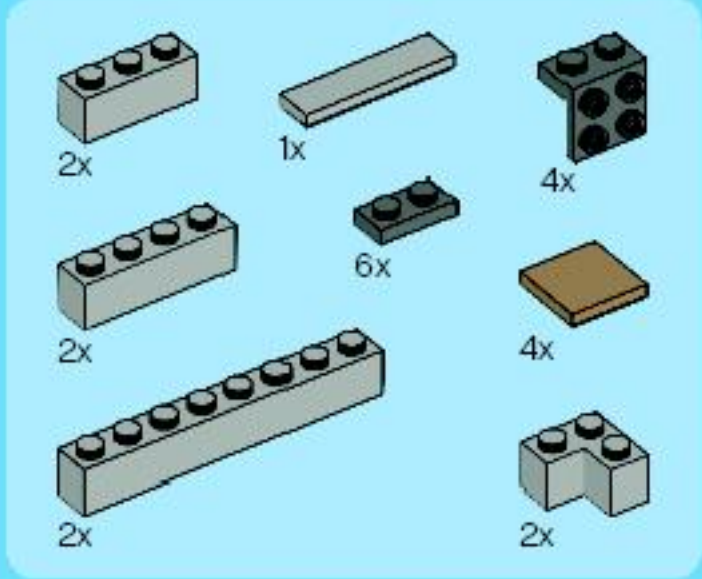

29

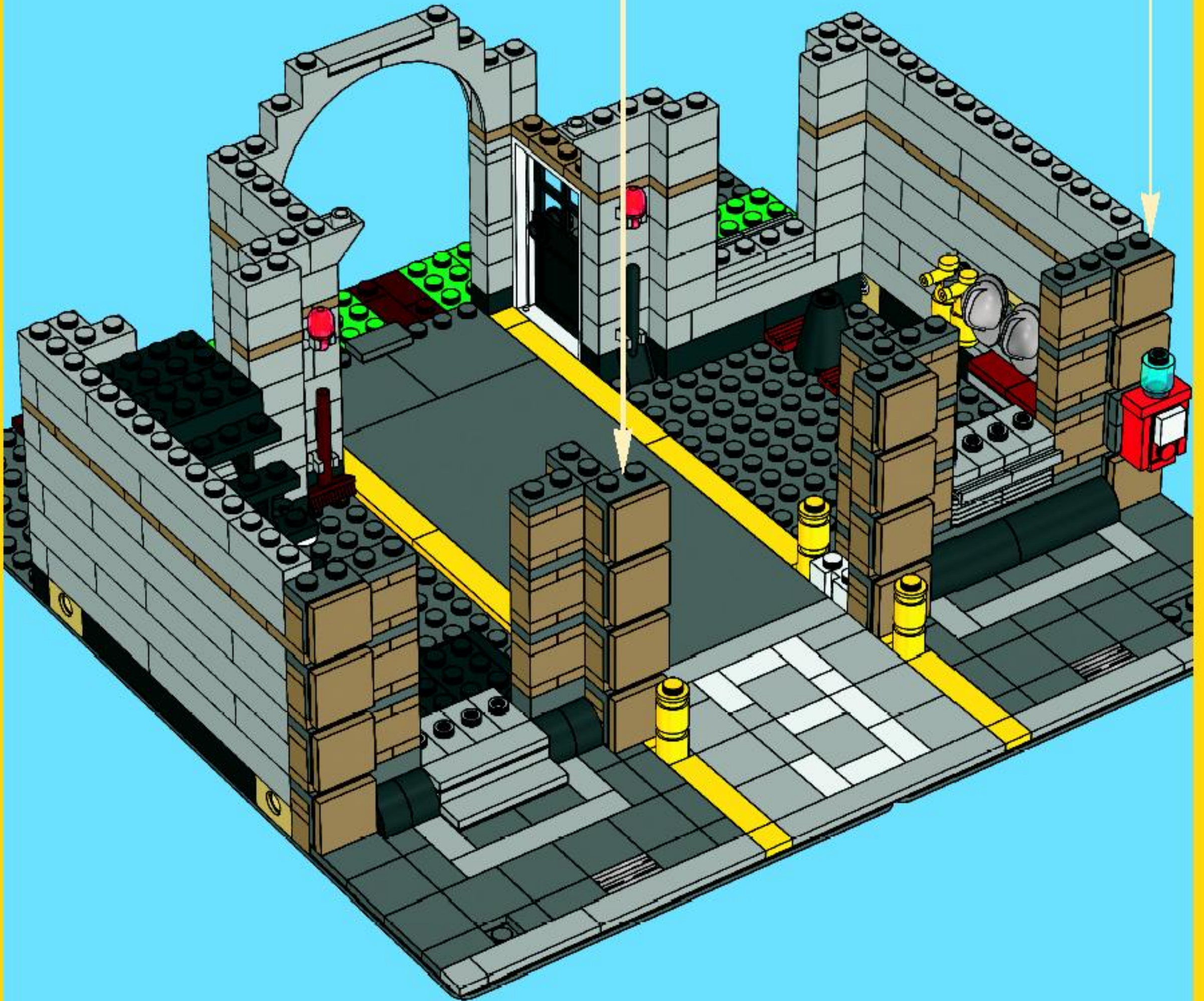



16x



2x



10x



2x

30

1

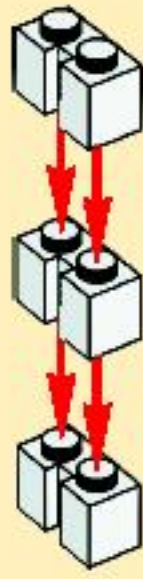

2

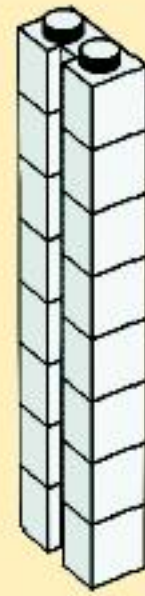

2x

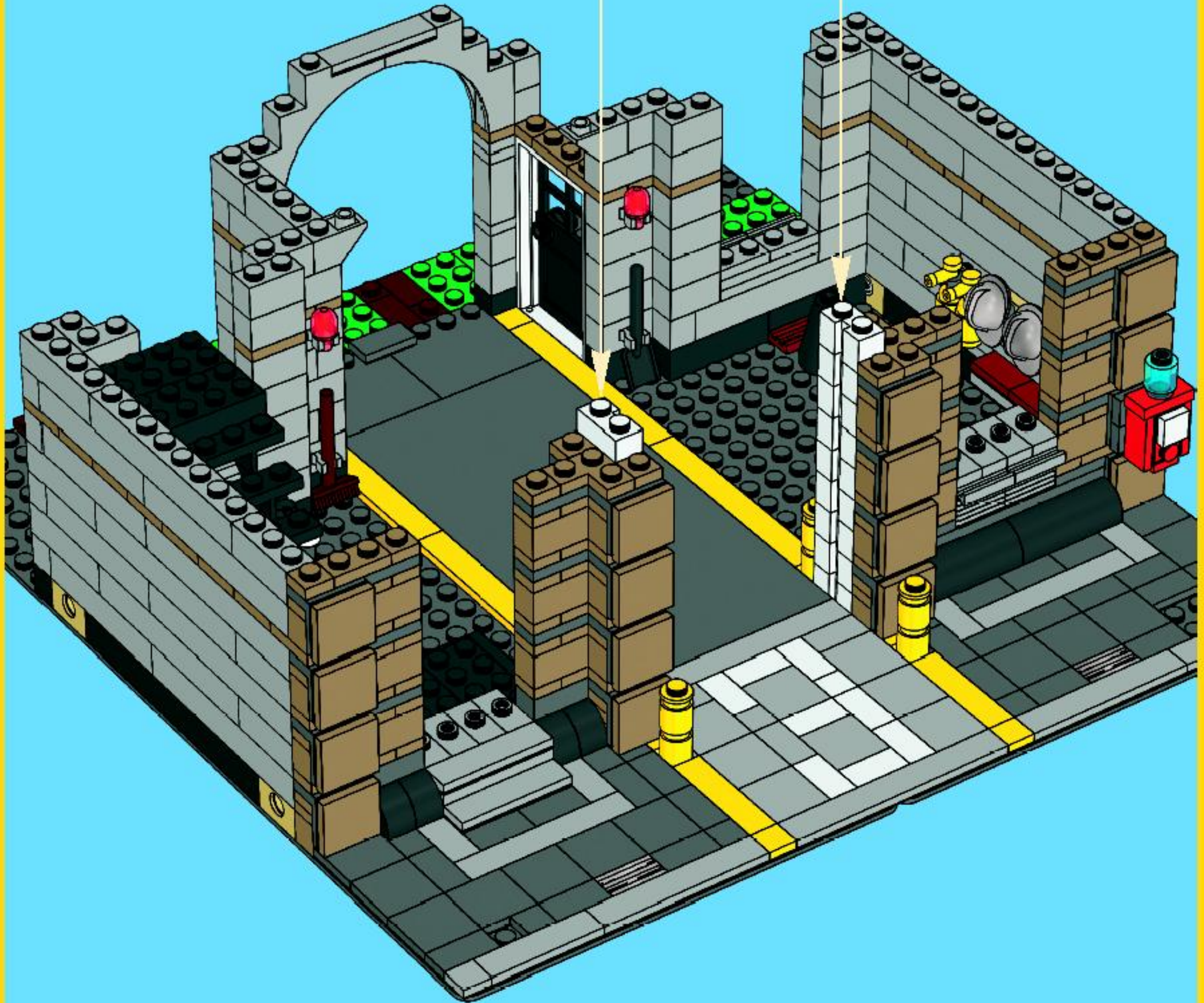



3x



3x

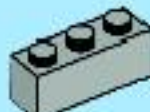

1x

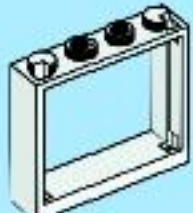

1x

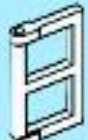

2x

31

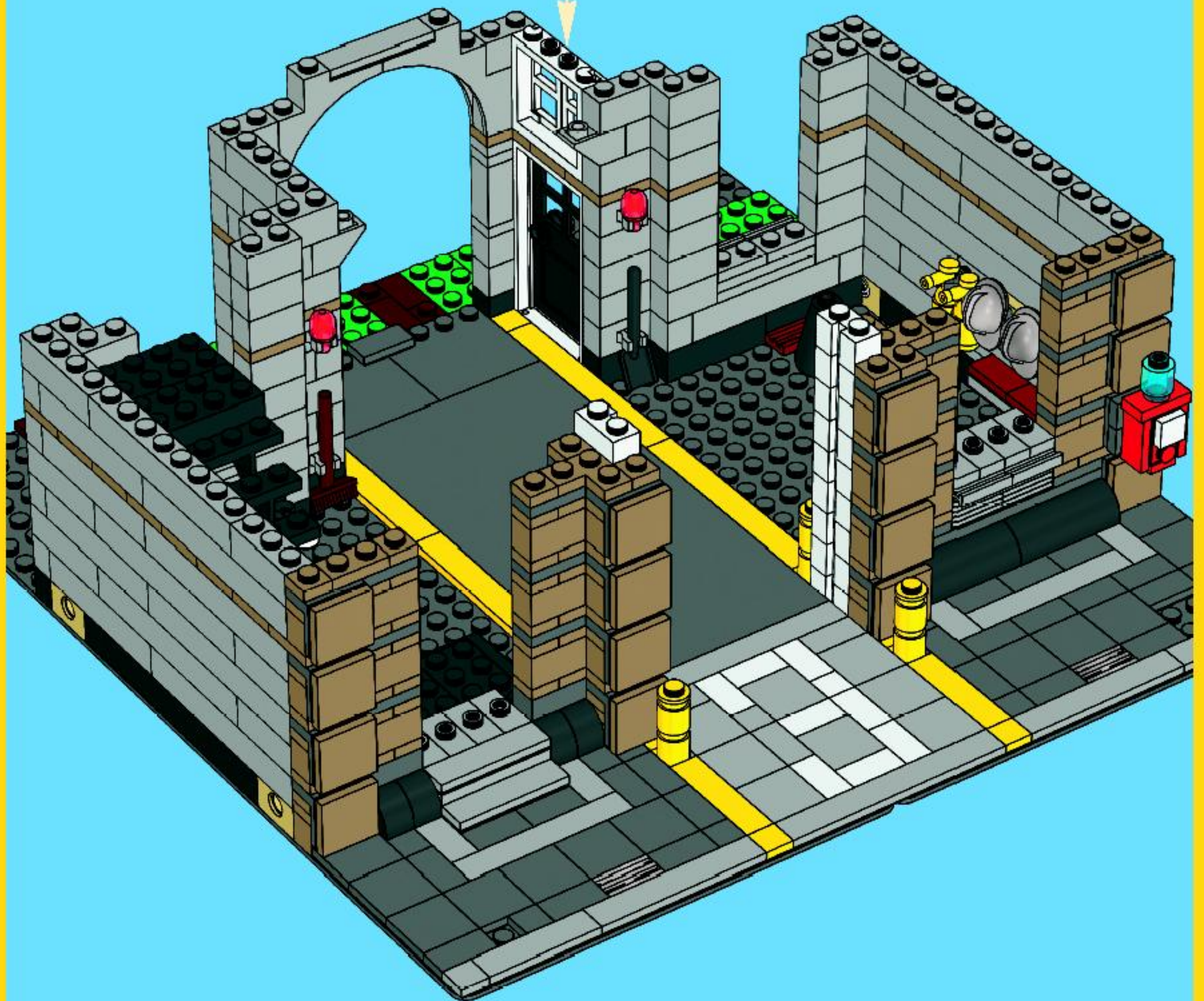
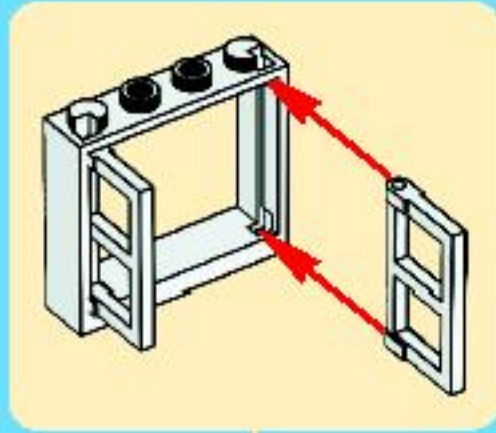

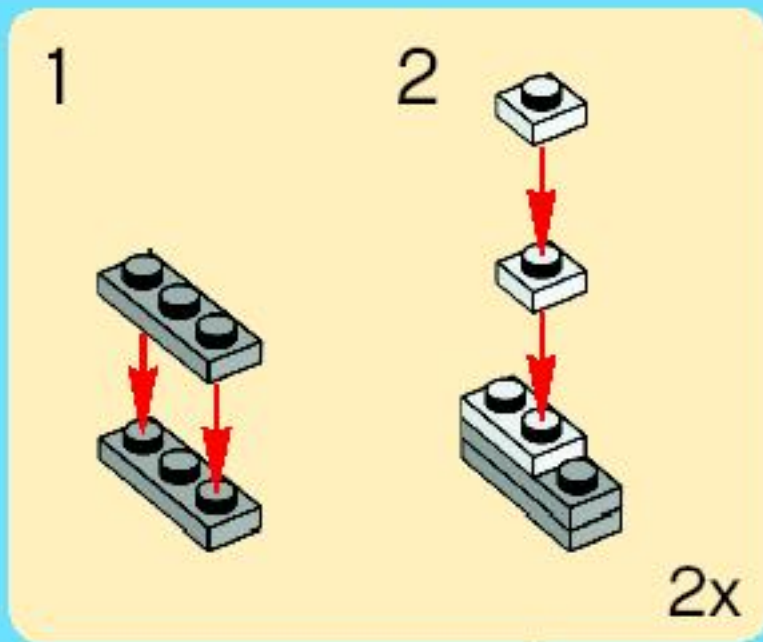
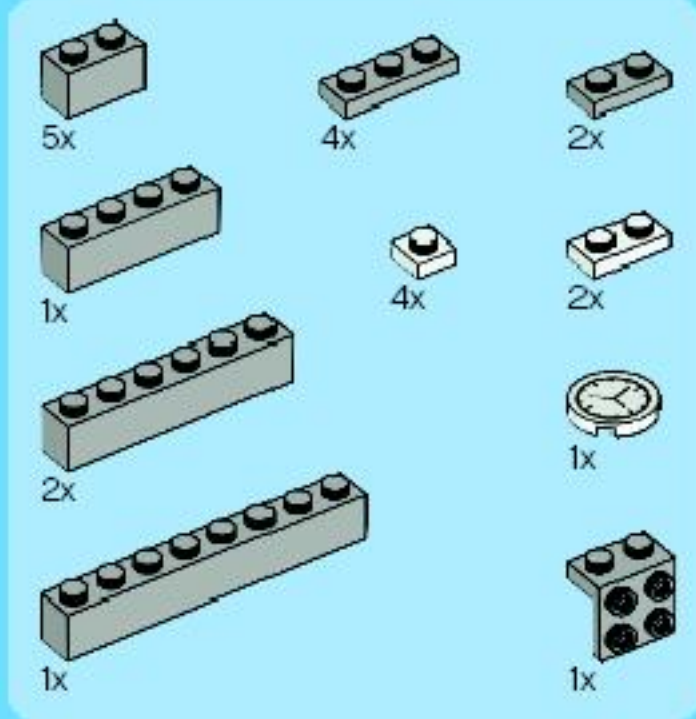

32

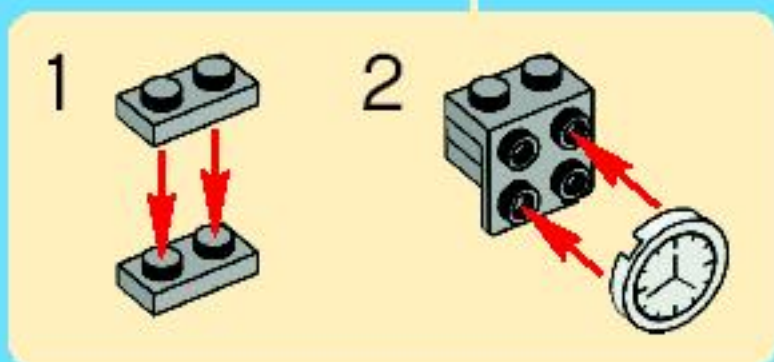
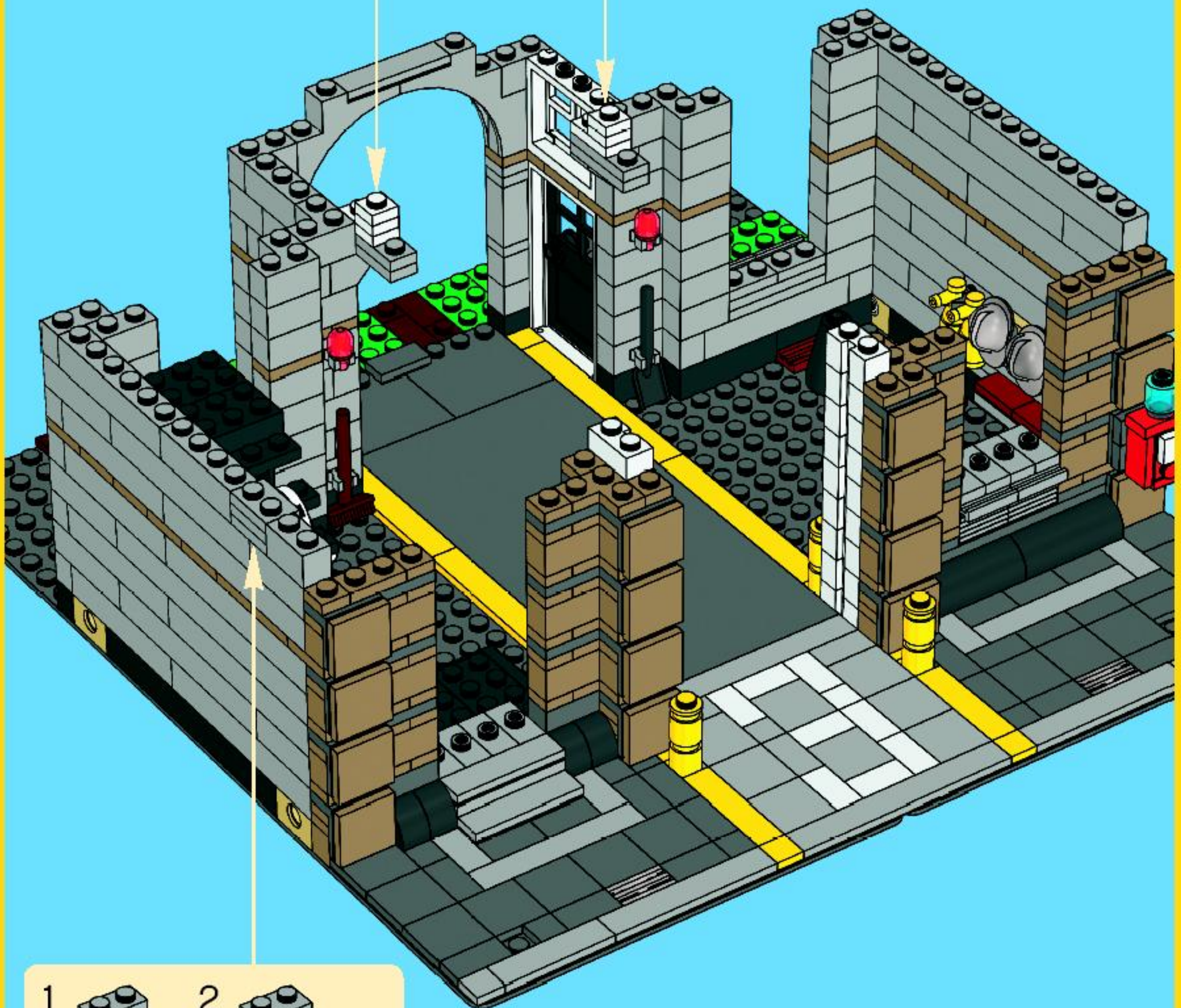

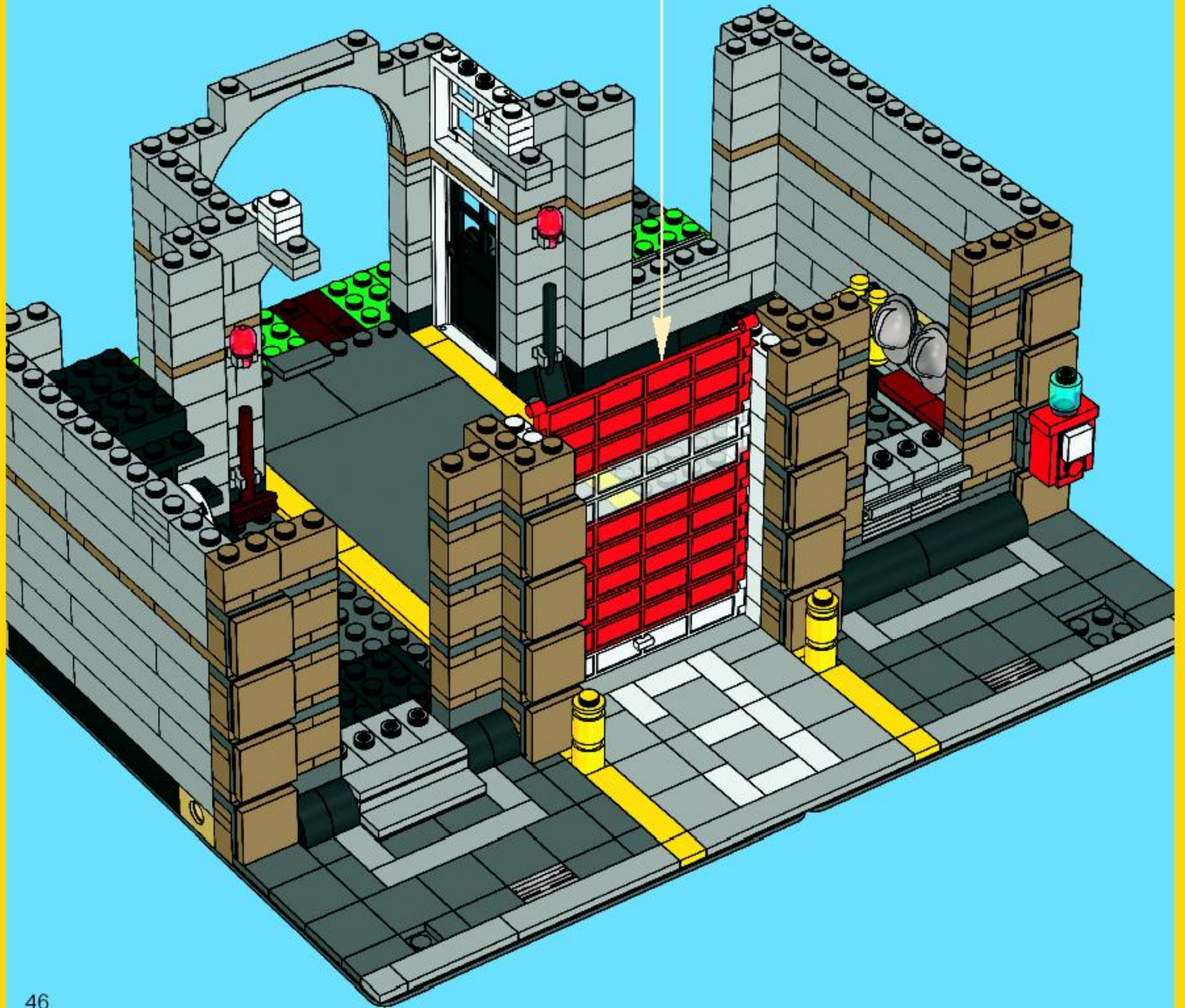
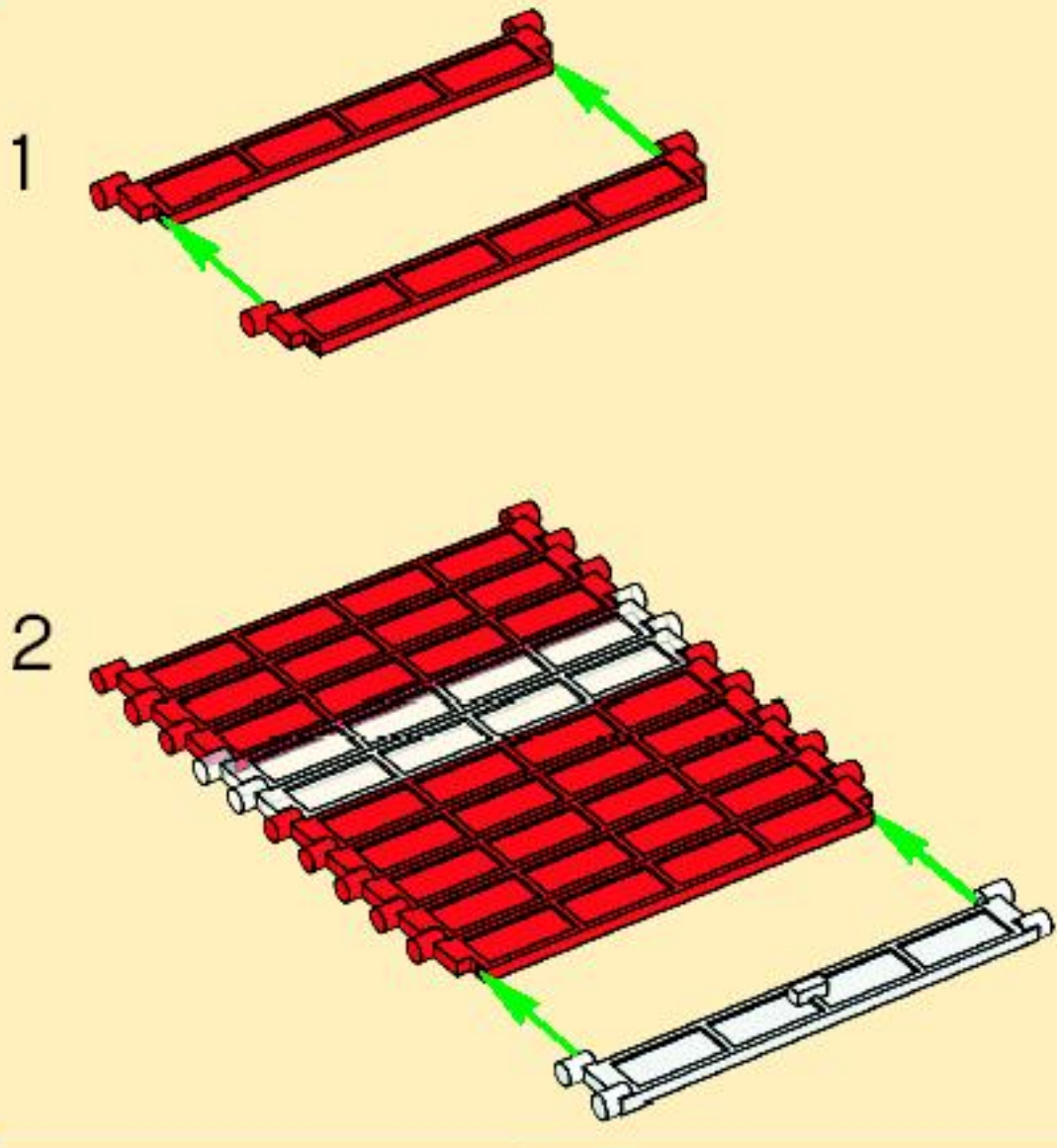
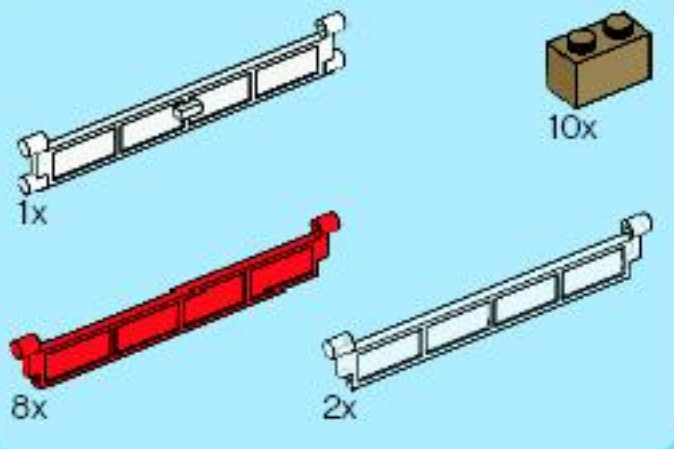

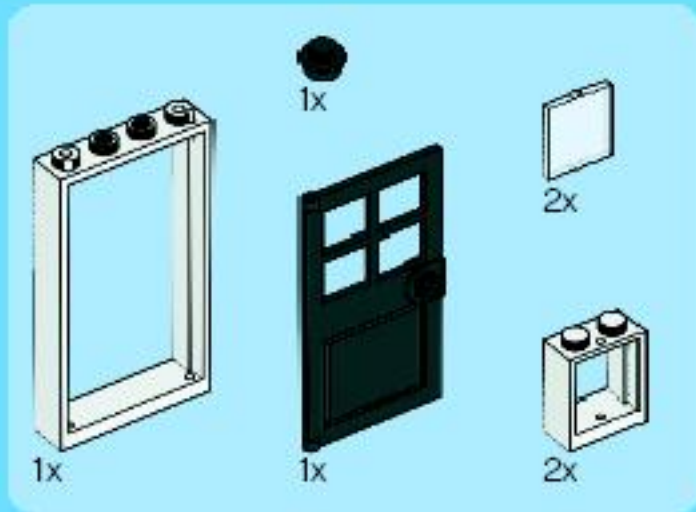

34

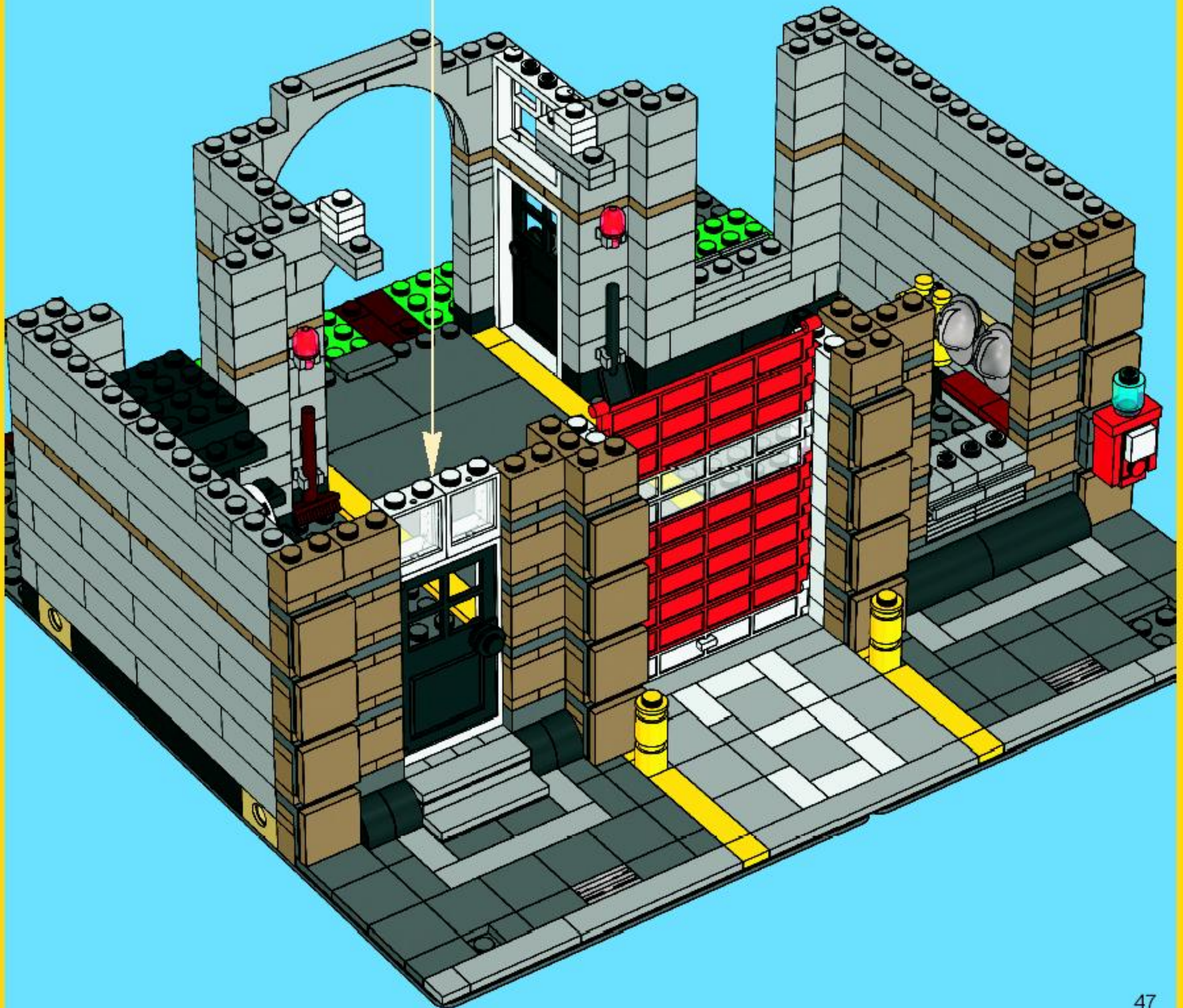
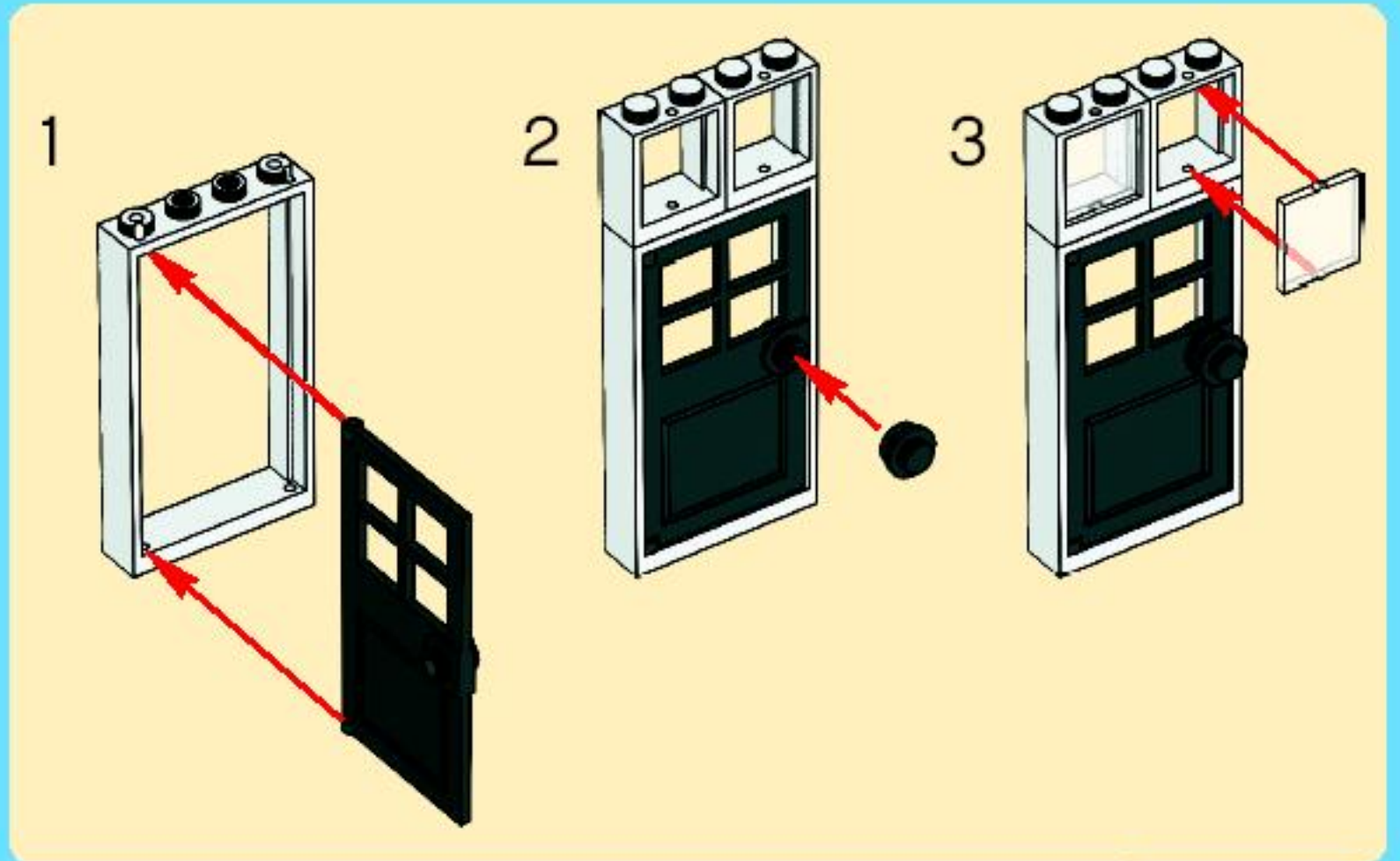

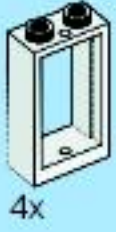

35

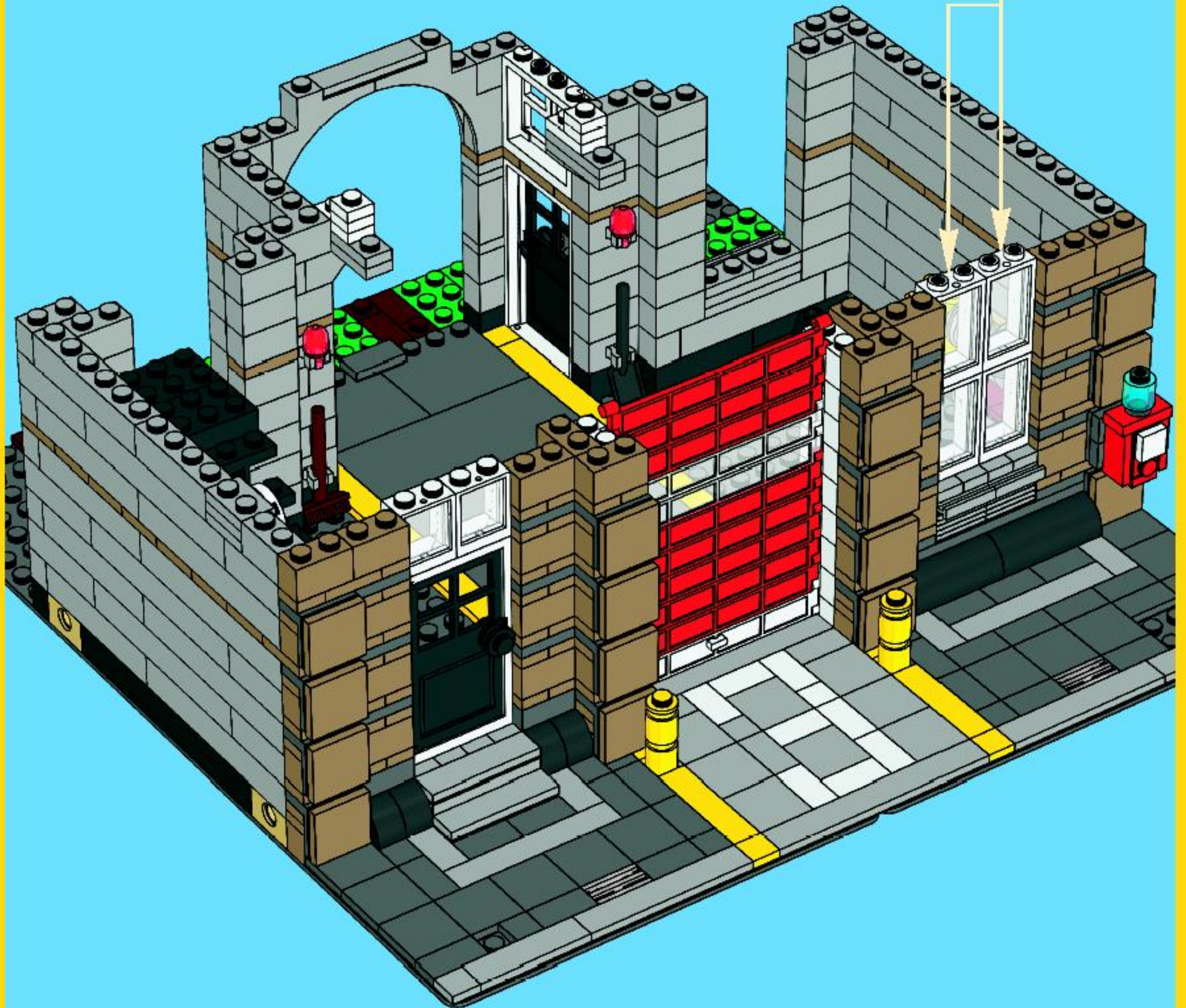
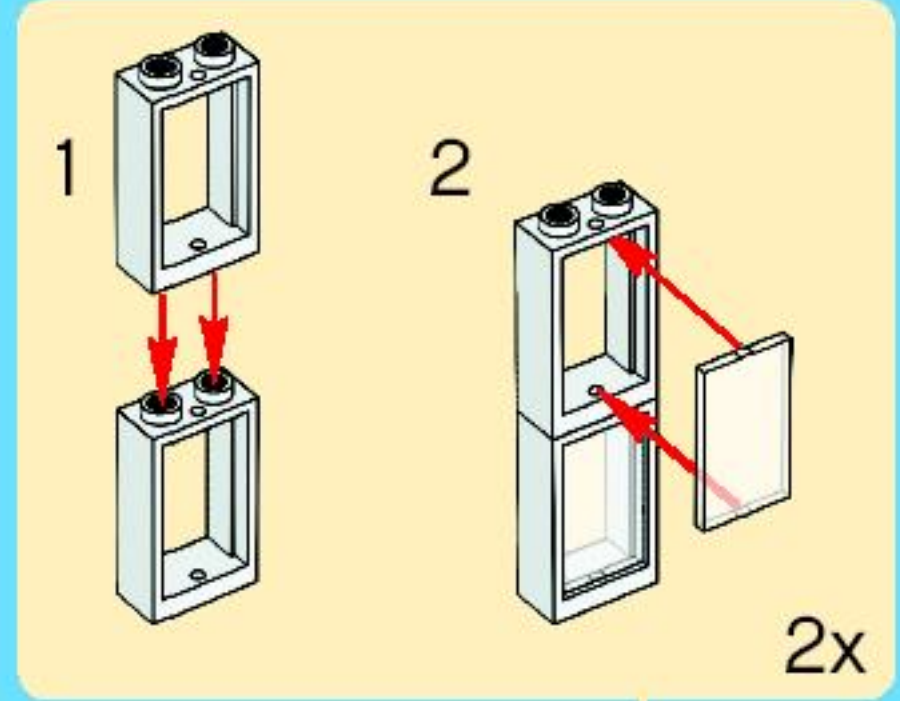

- 2x
- 8x
- 2x
- 10x
- 2x

36

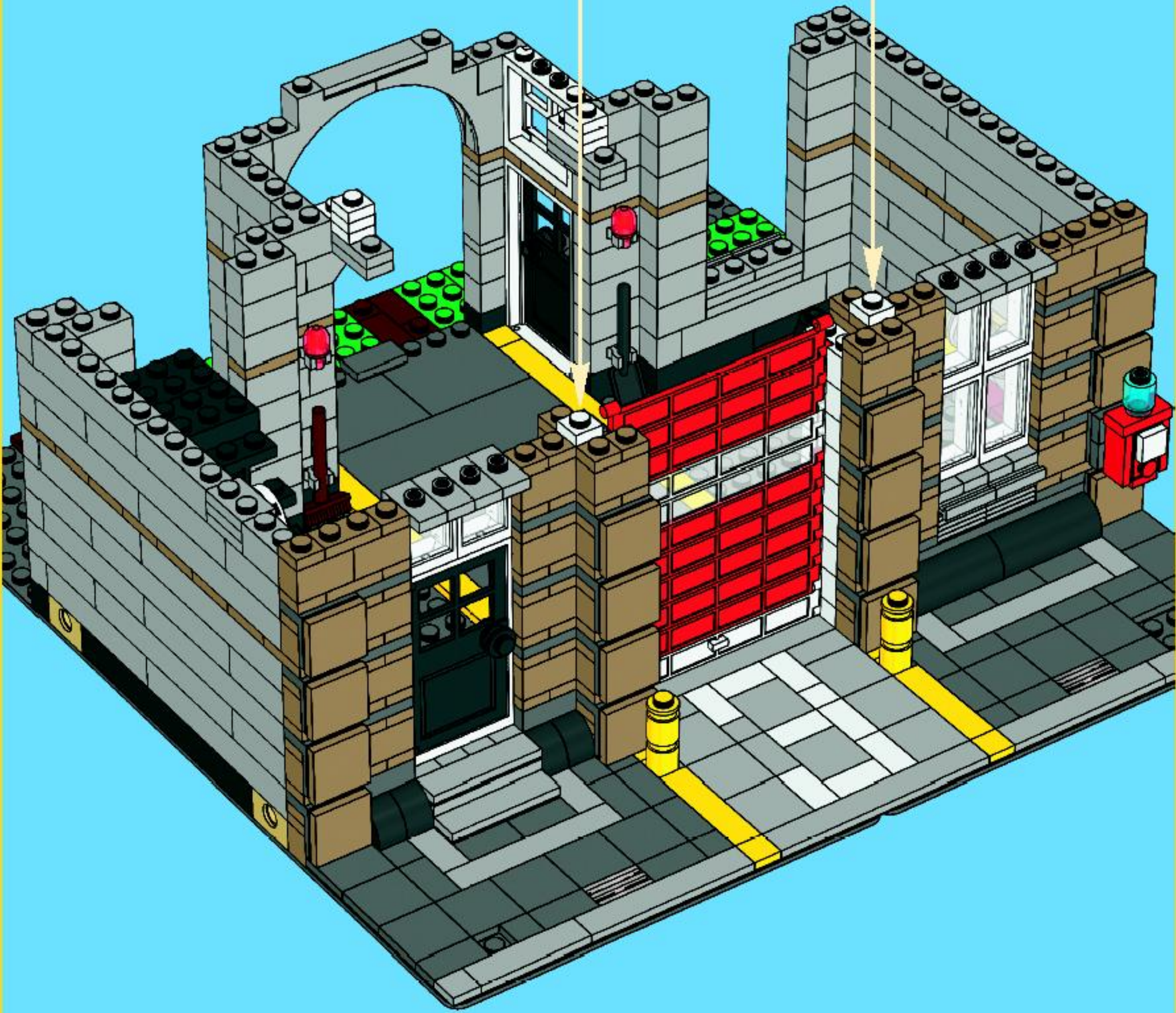
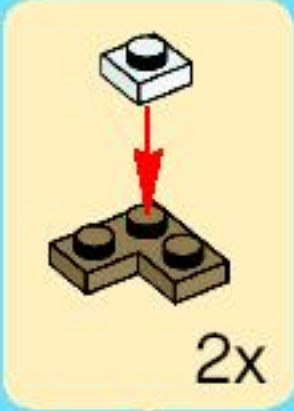

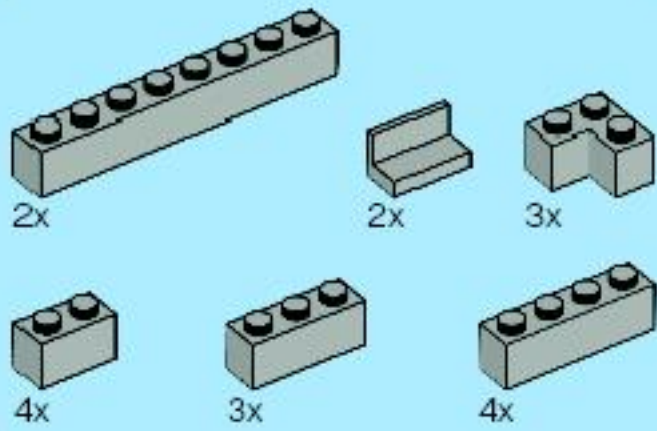

37

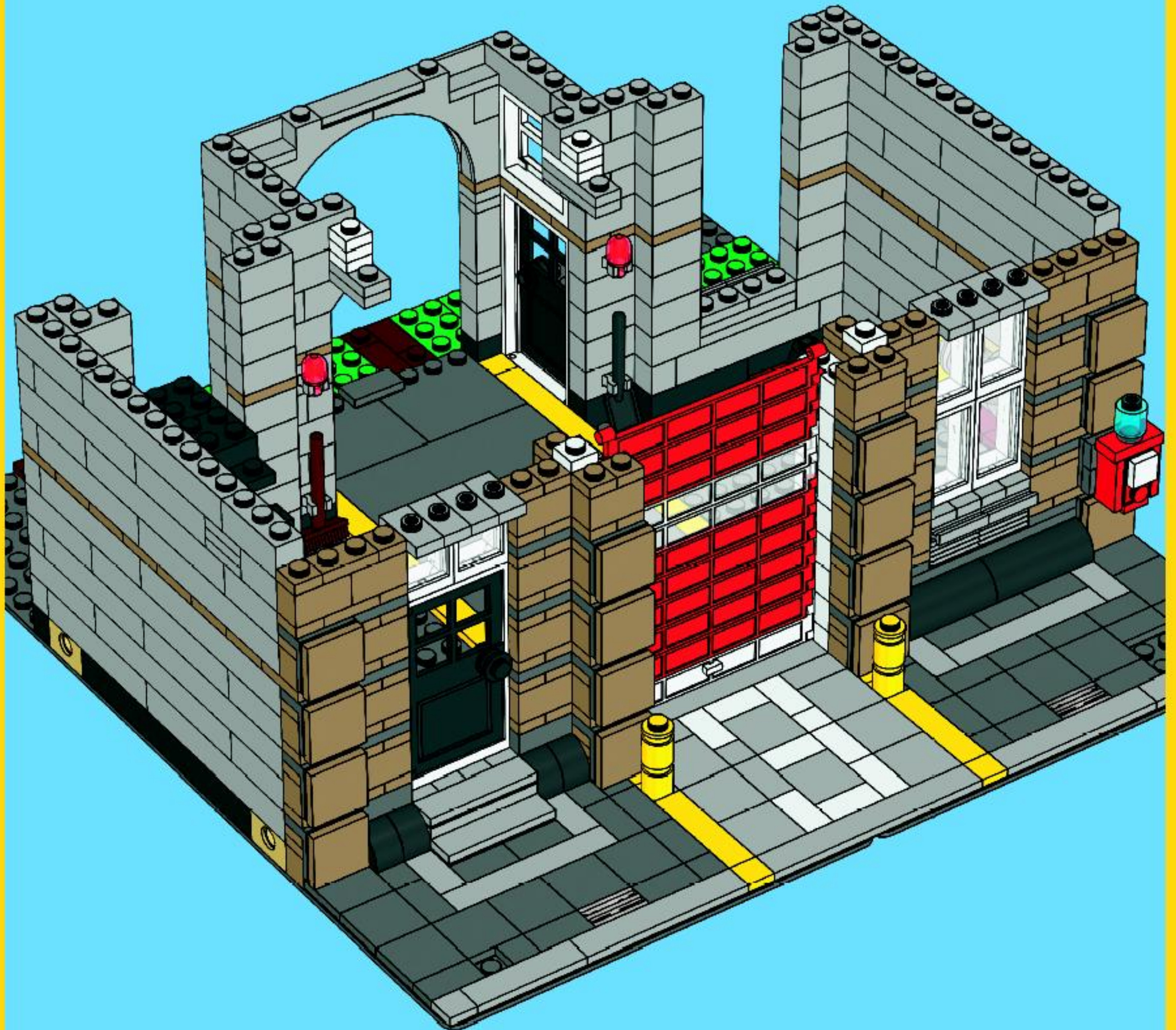

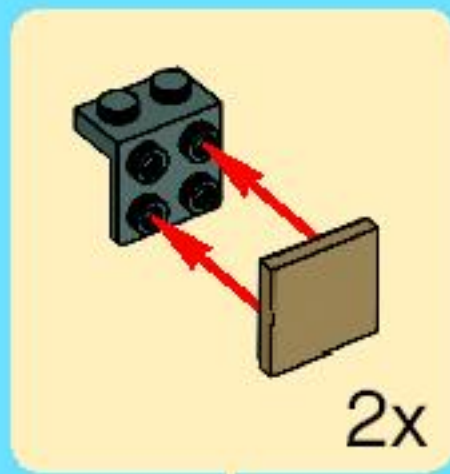
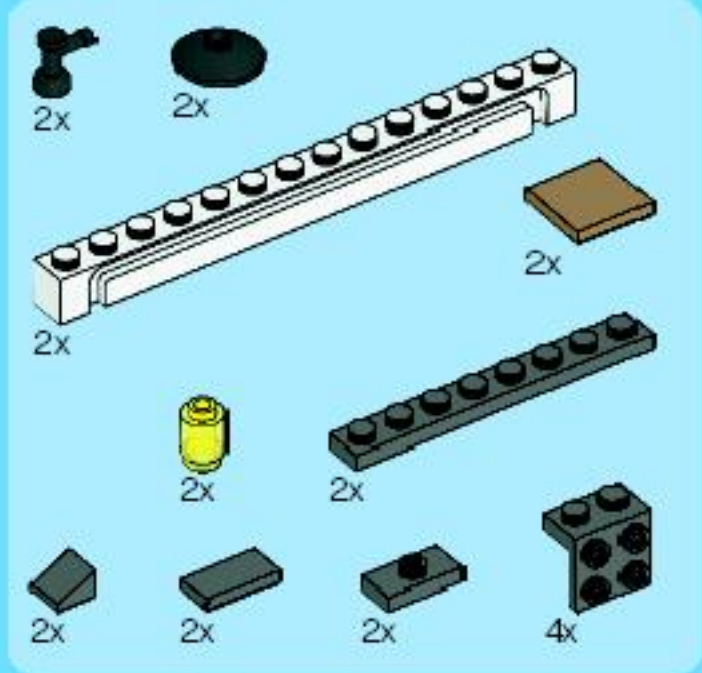

38

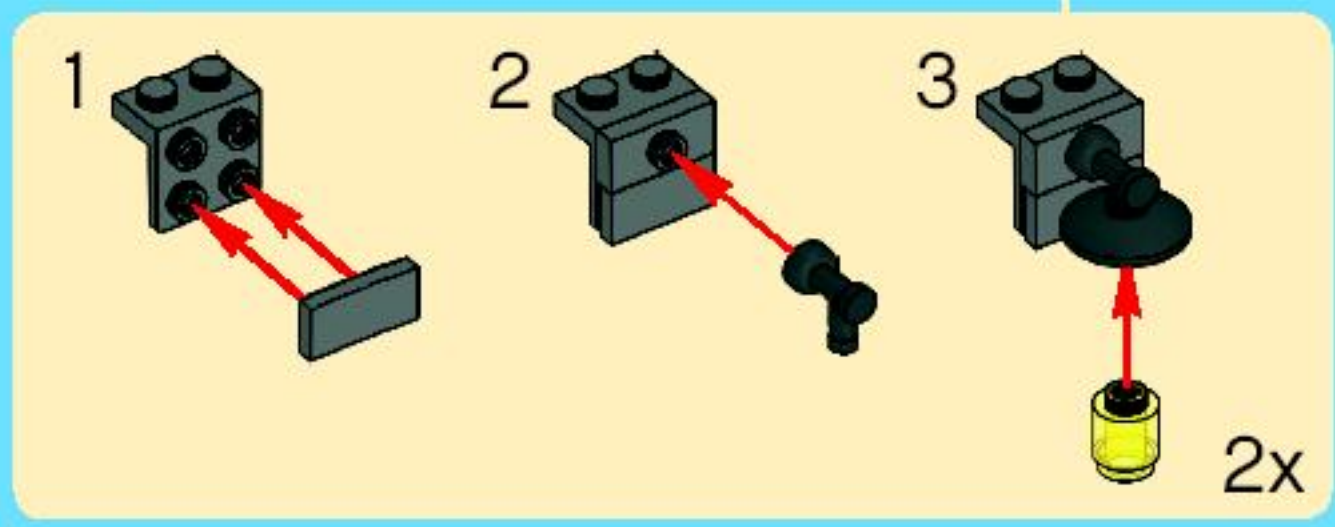
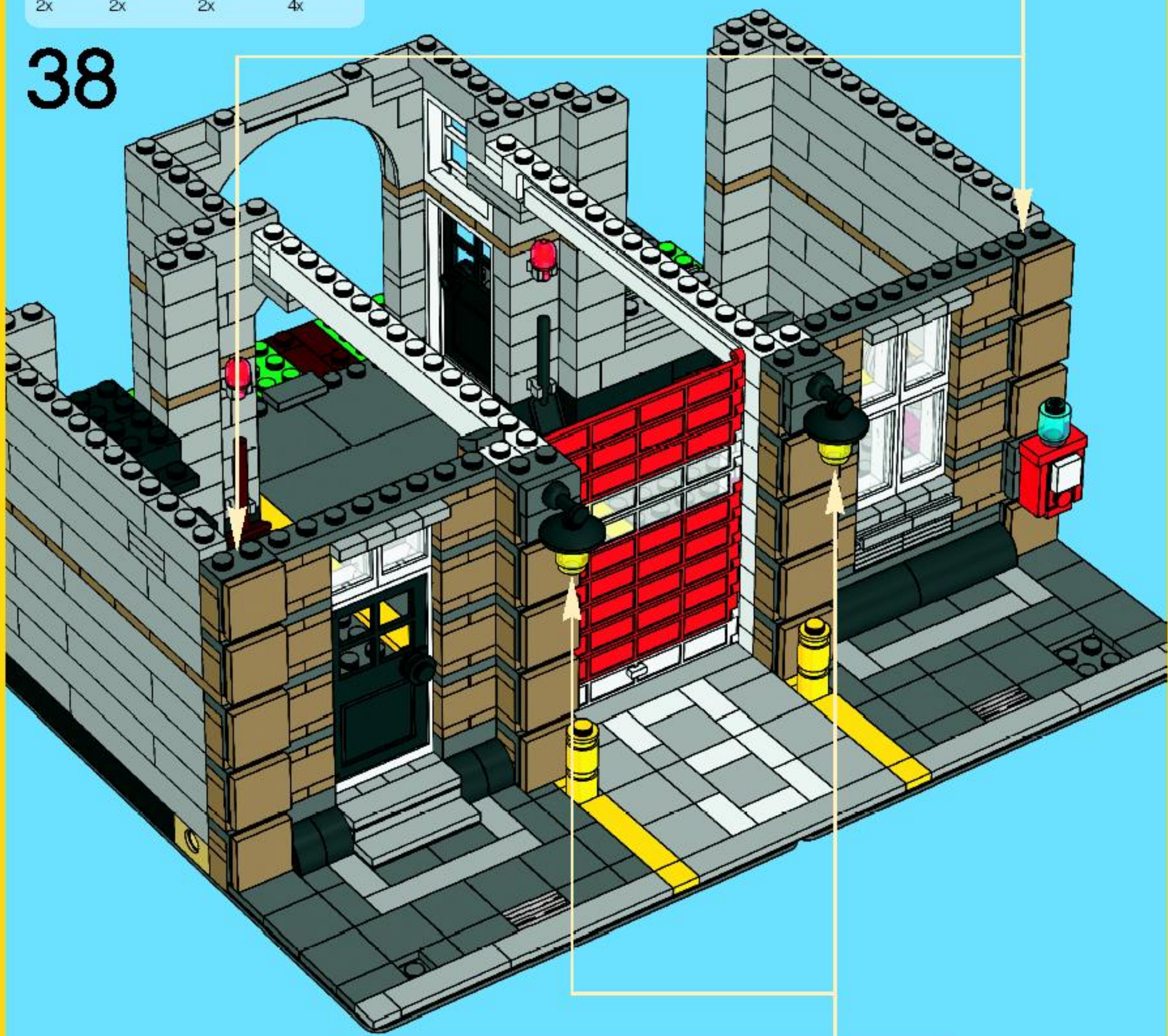

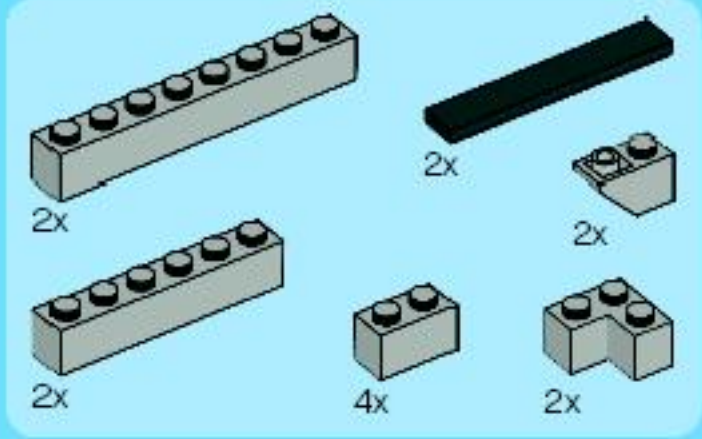

39

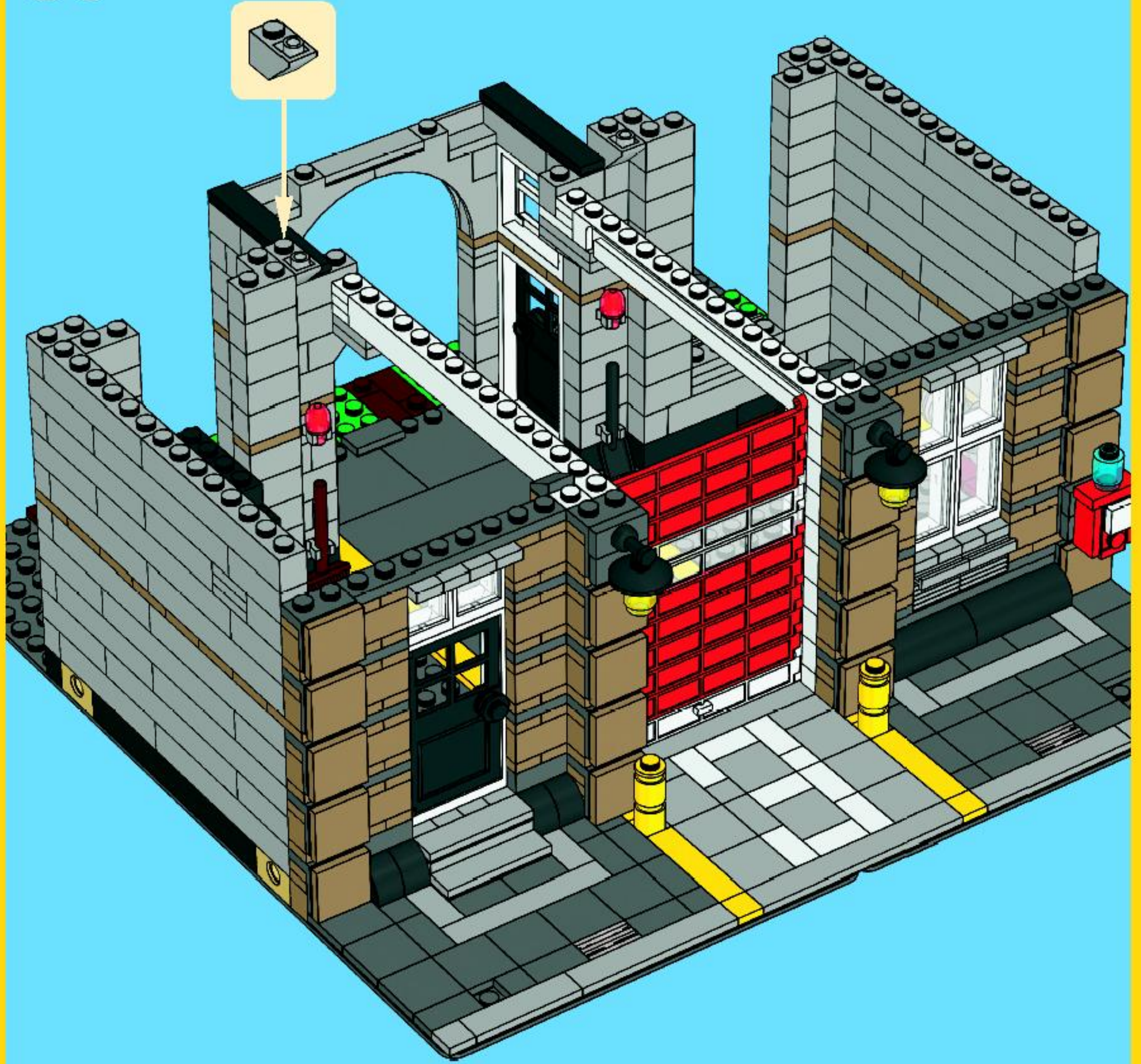

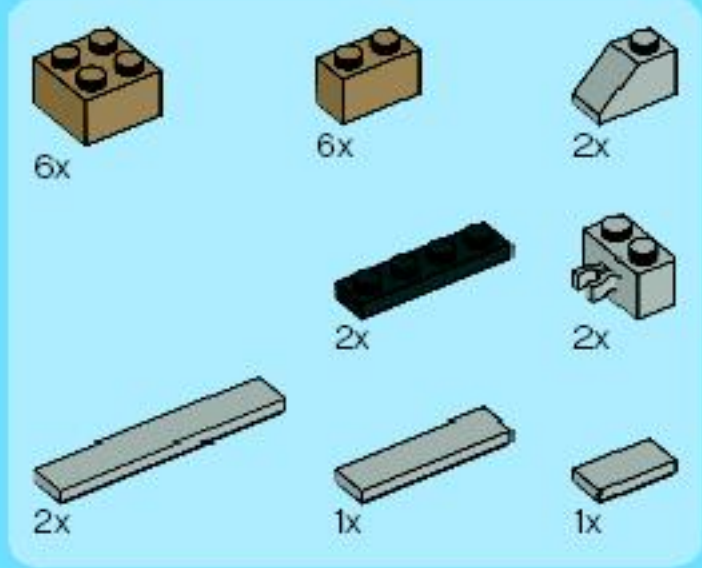

40

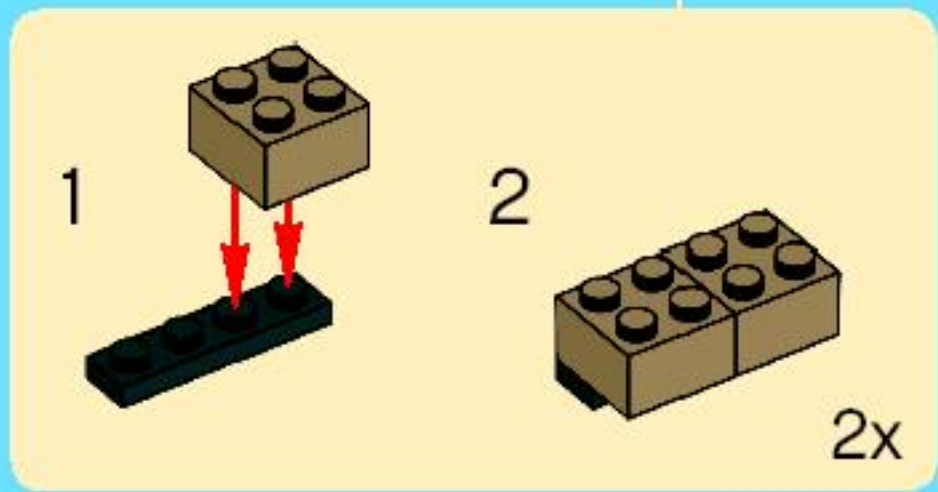
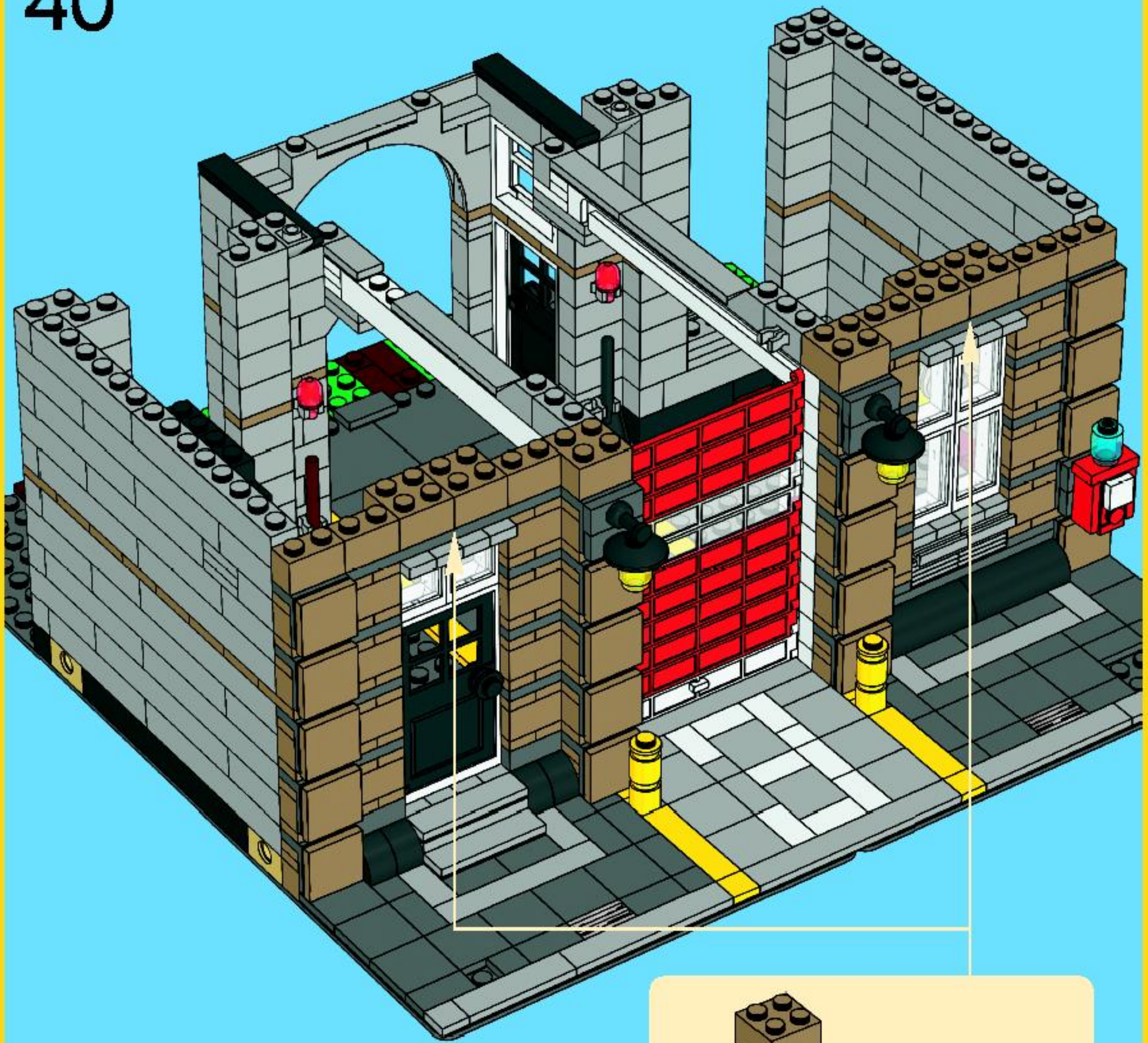

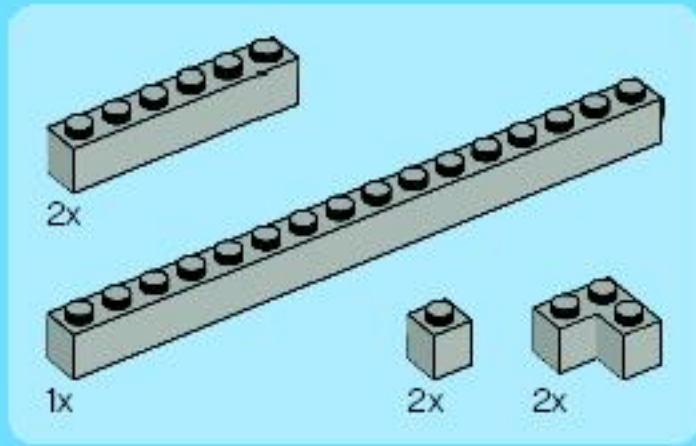

42

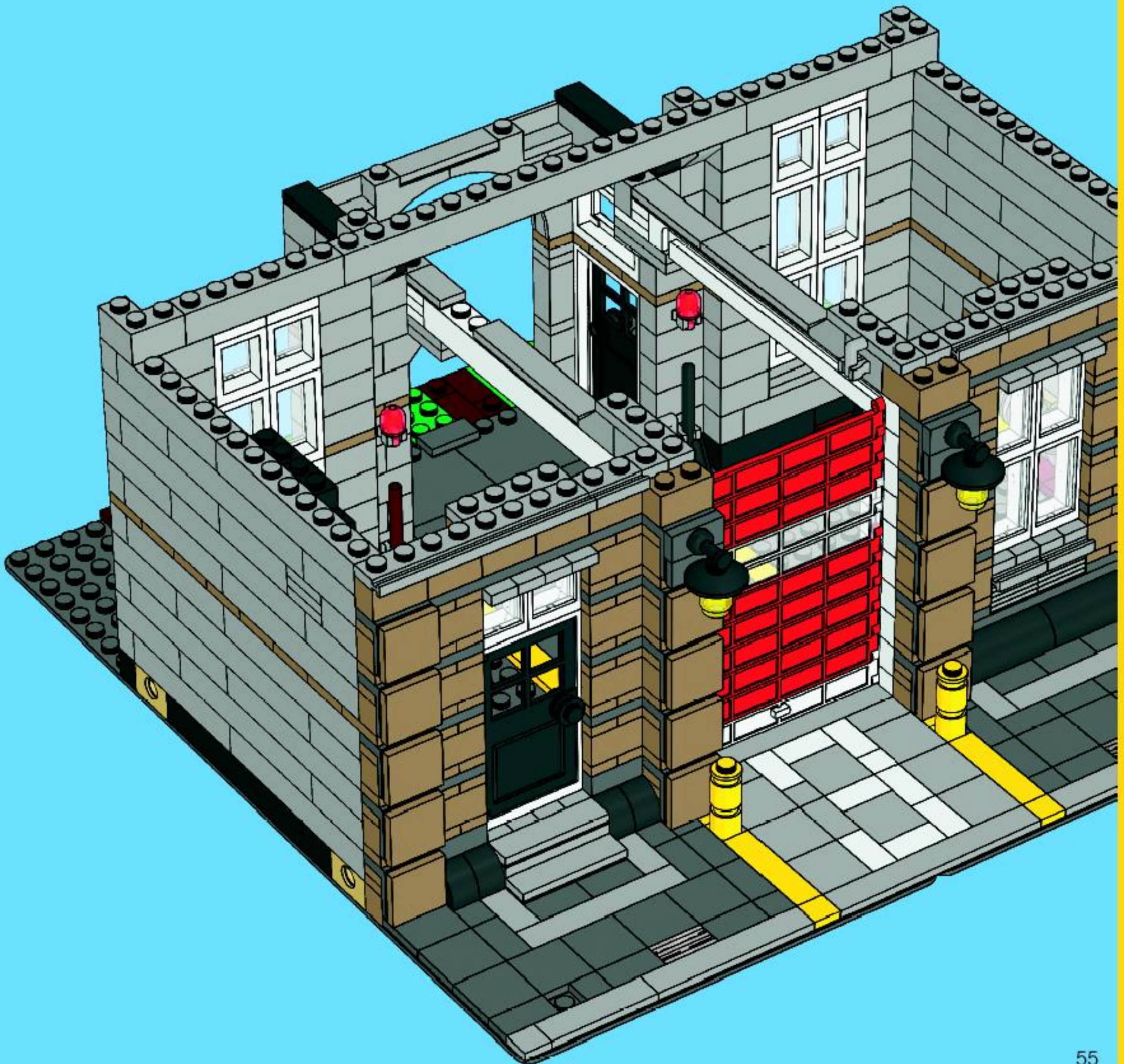

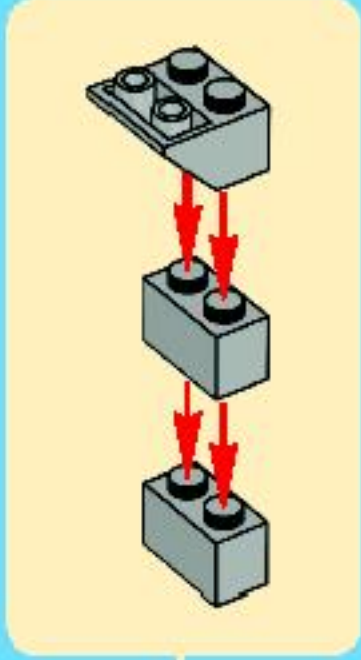
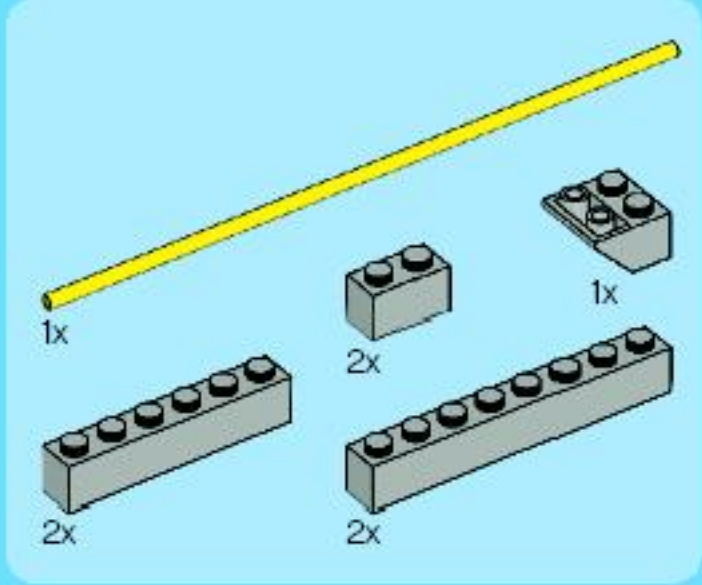

43

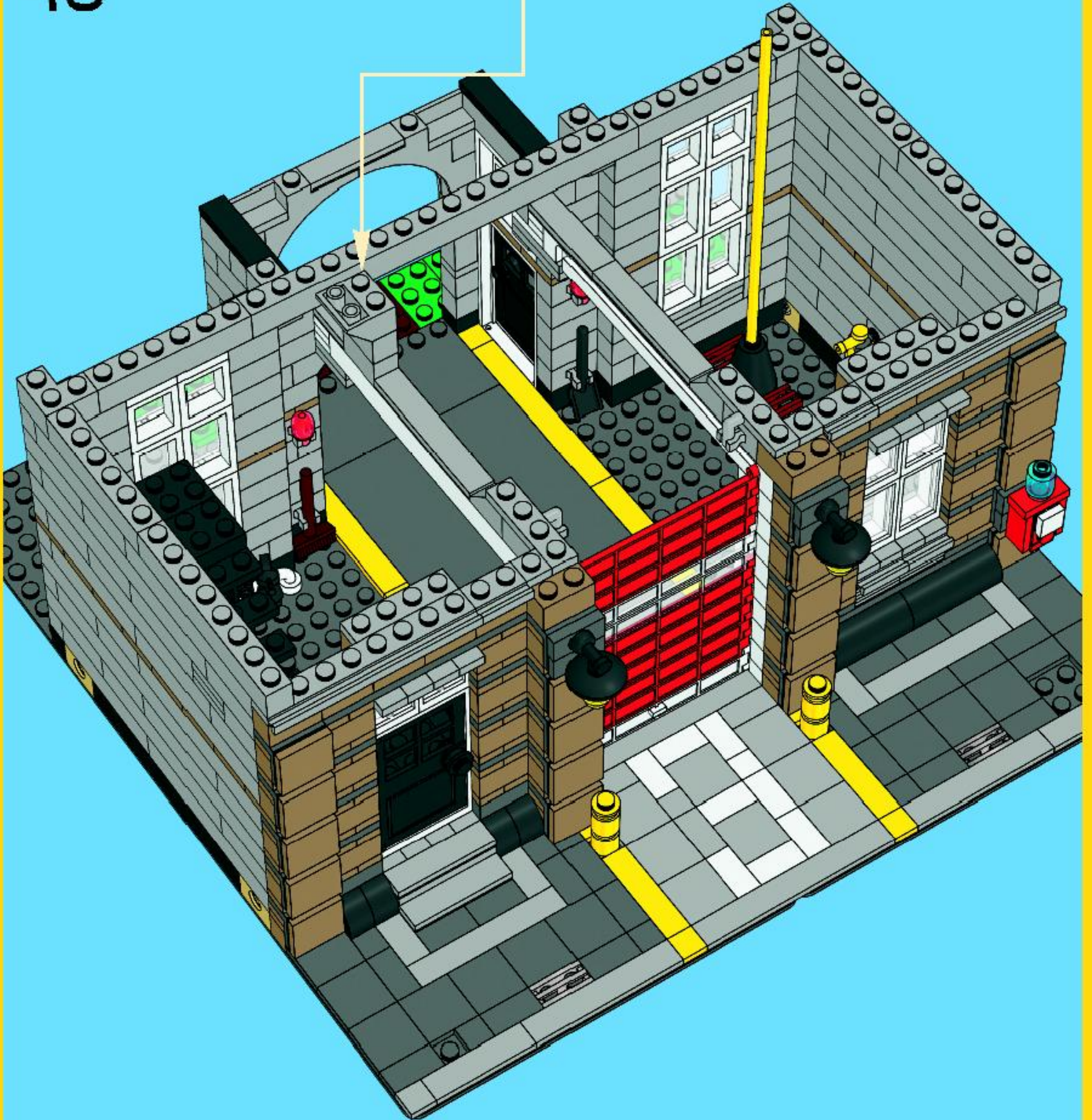

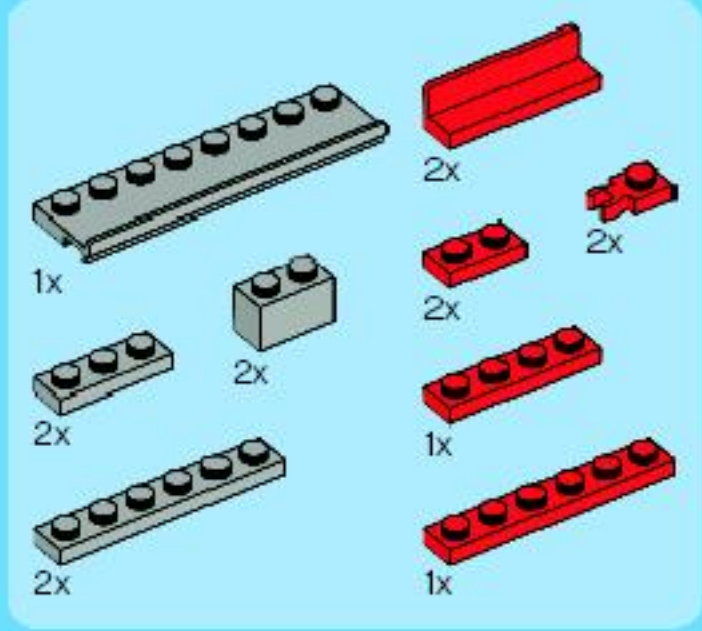

44

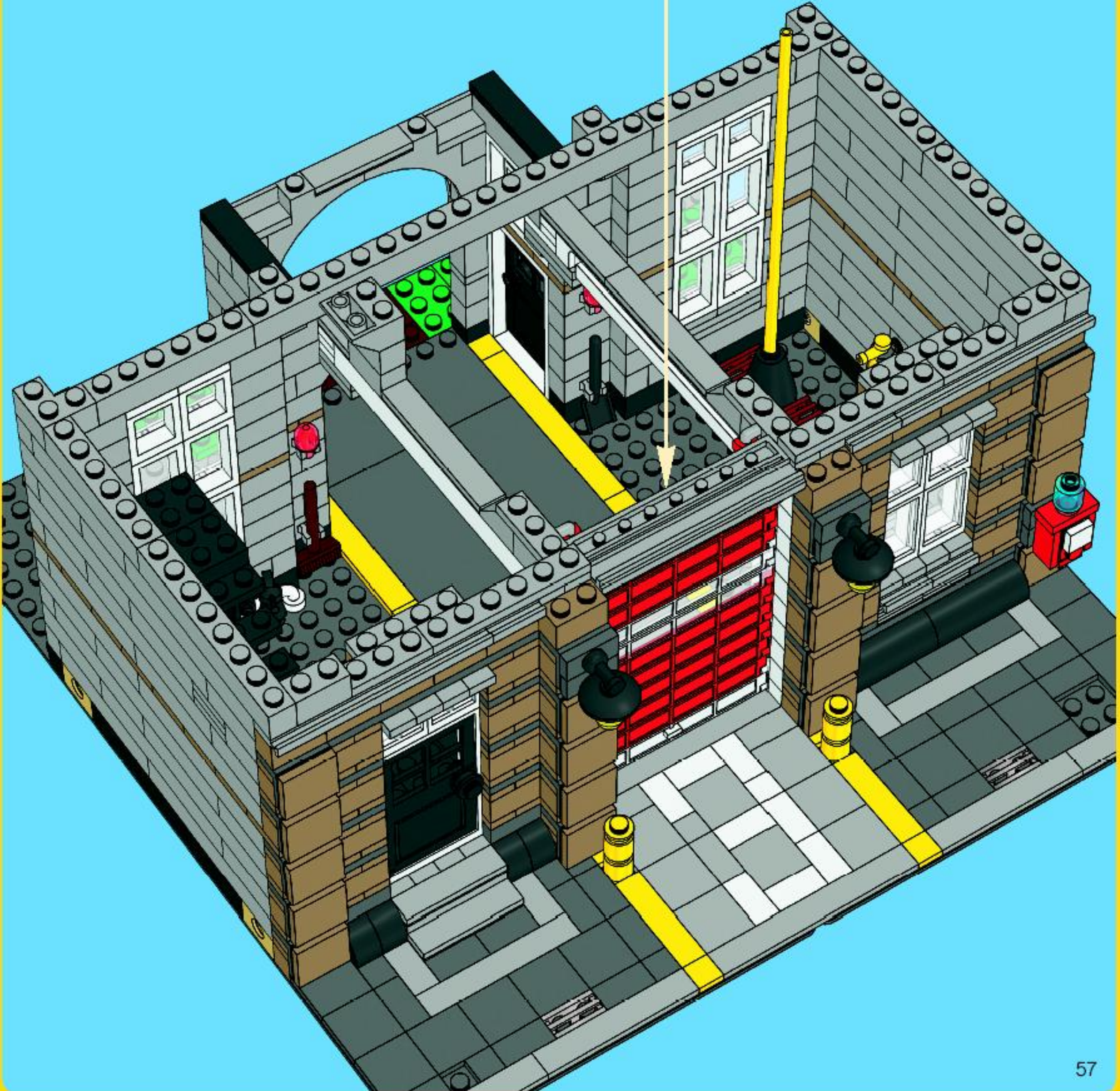
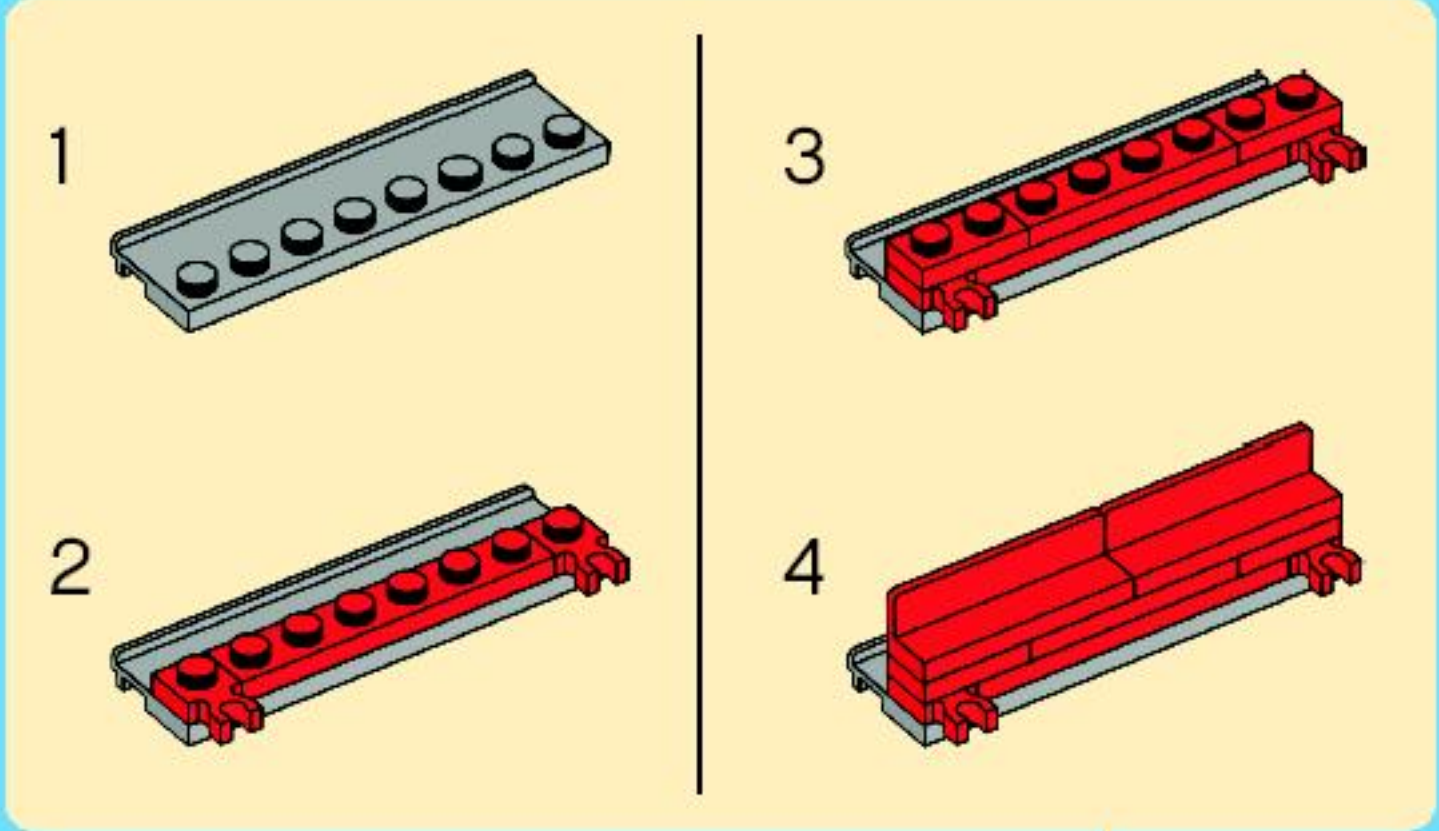

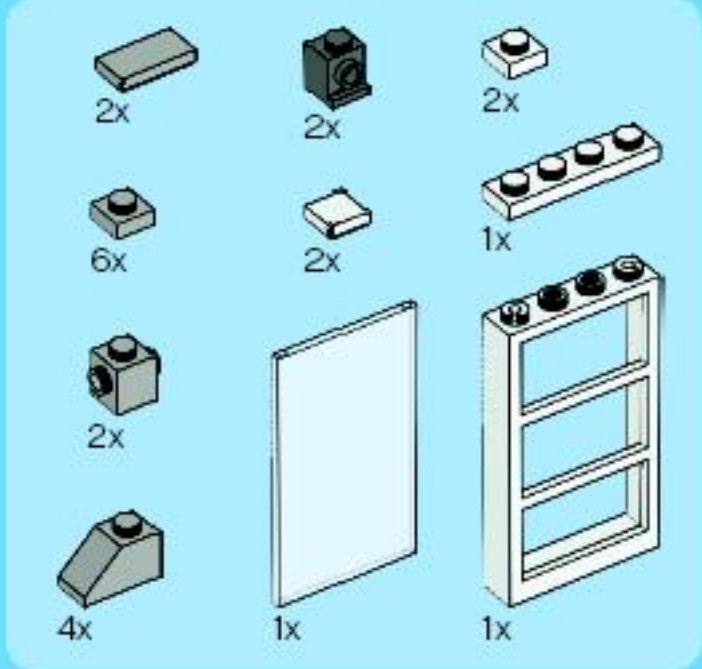

45

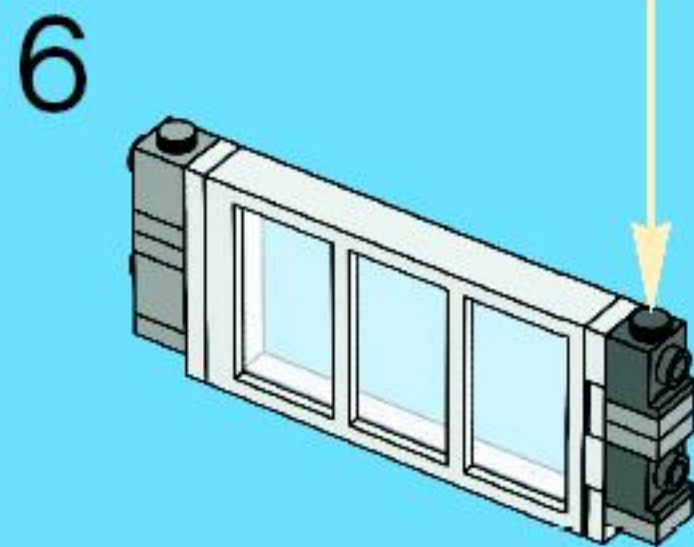
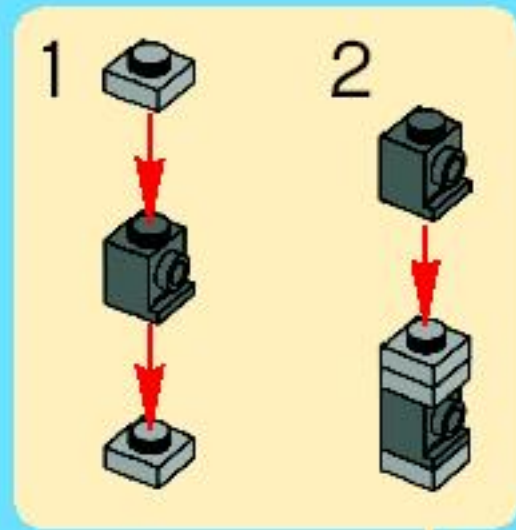
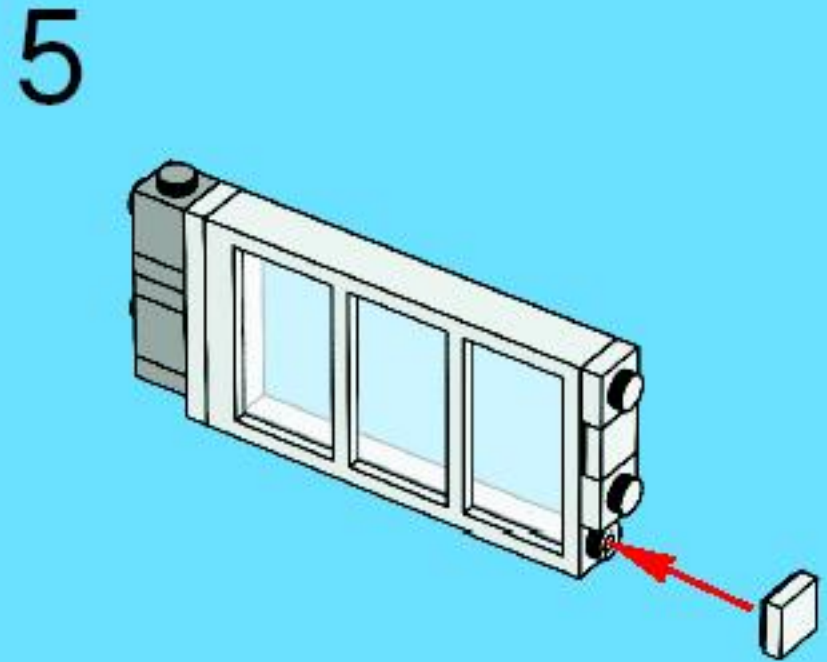
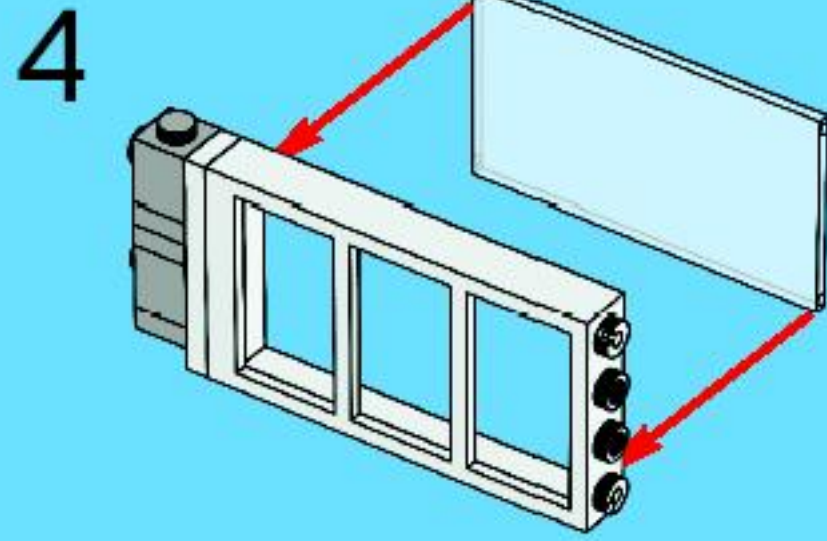
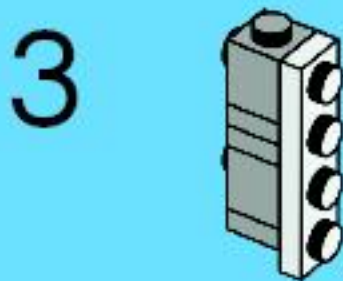
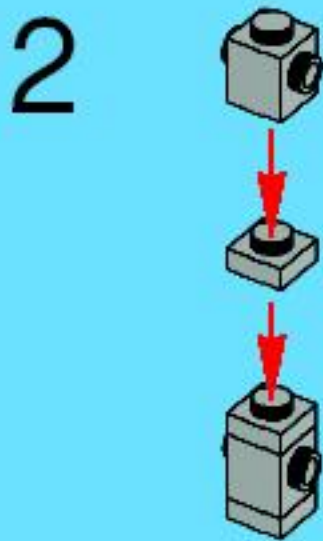
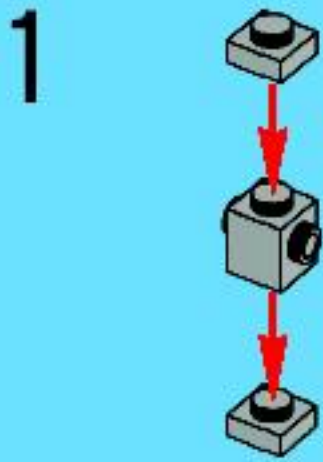

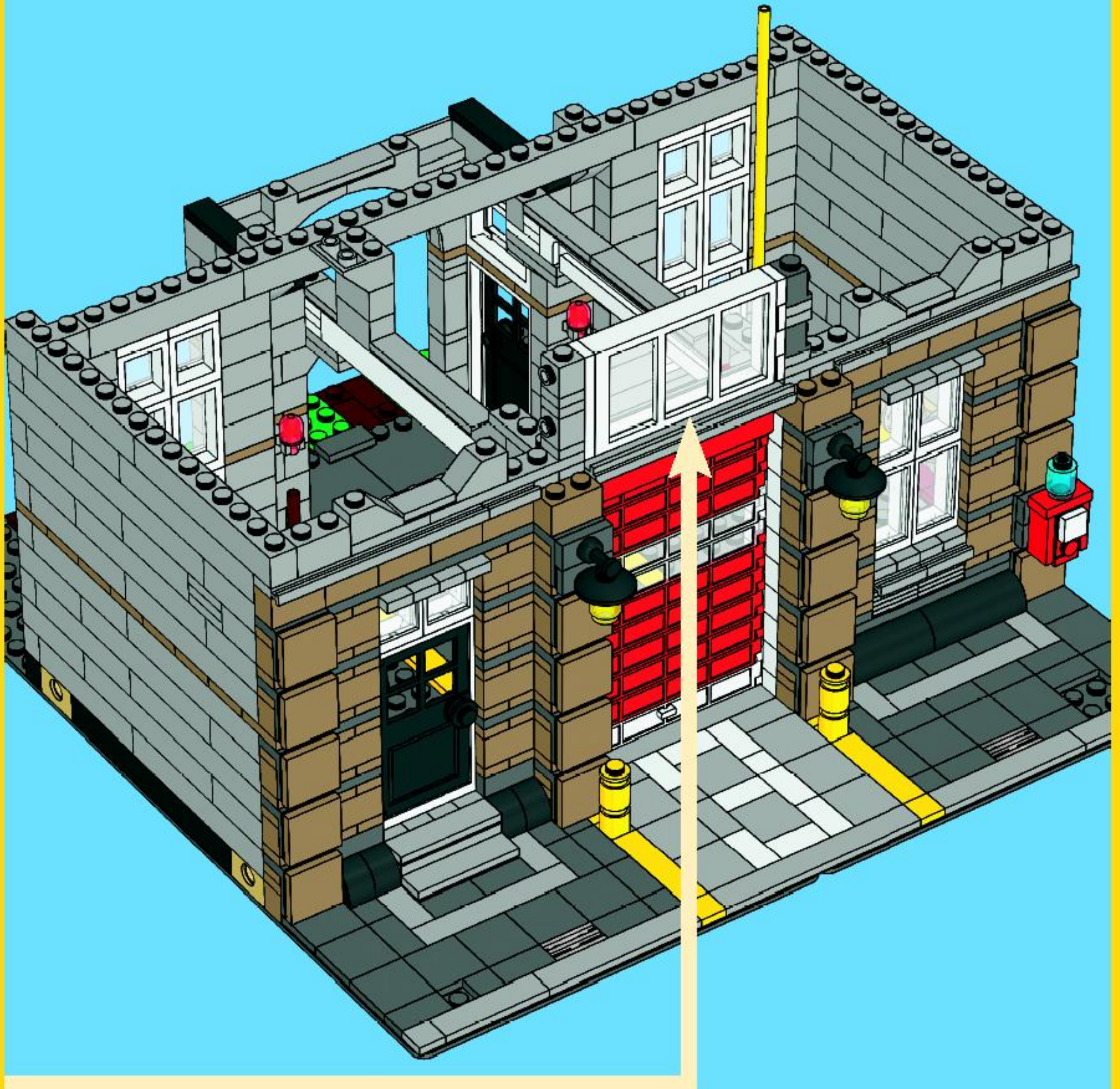

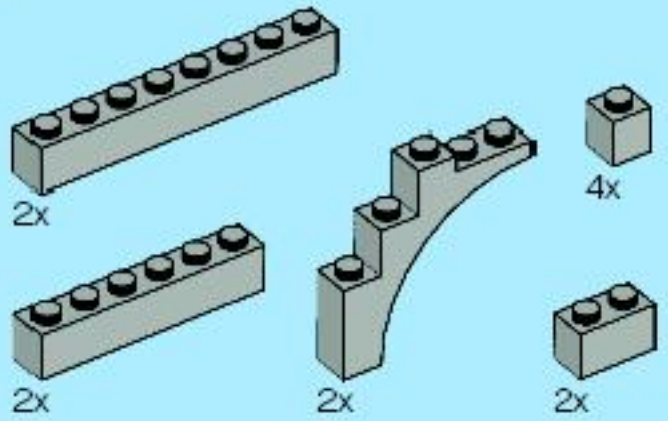

46

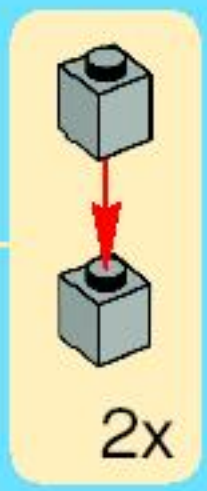
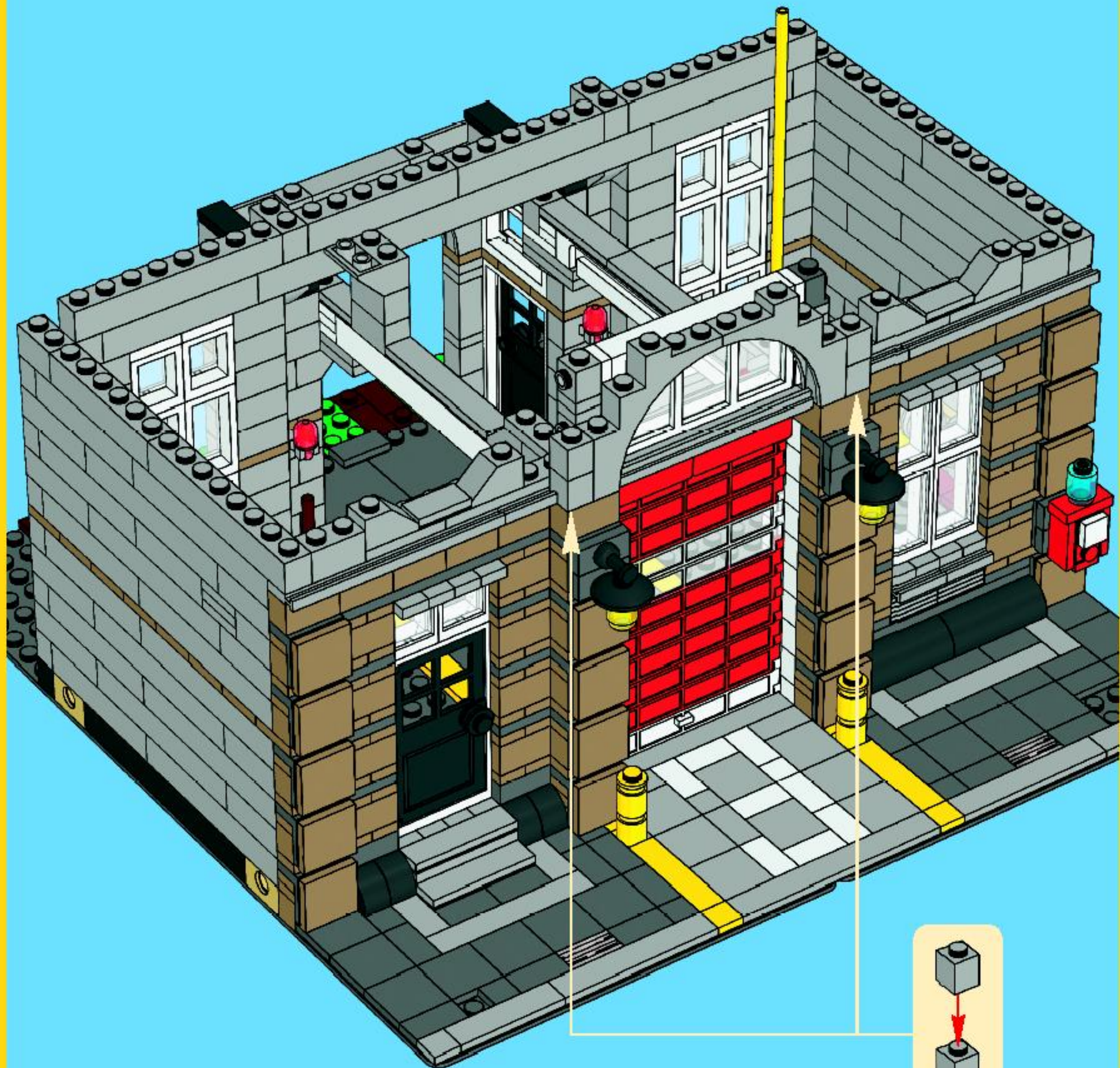



6x



1x



1x



1x



2x

47

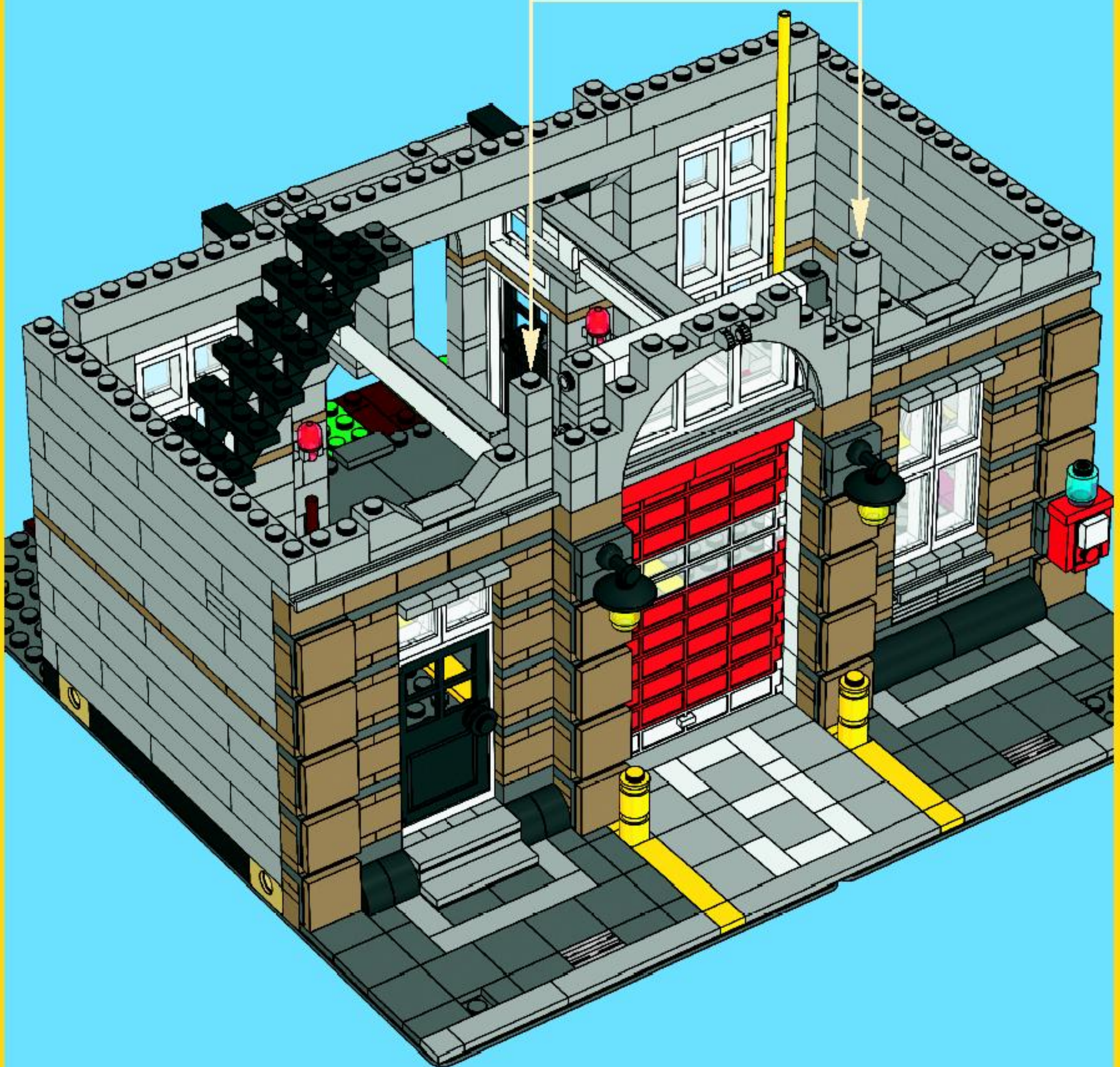



4x



4x



2x

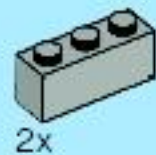

2x

48

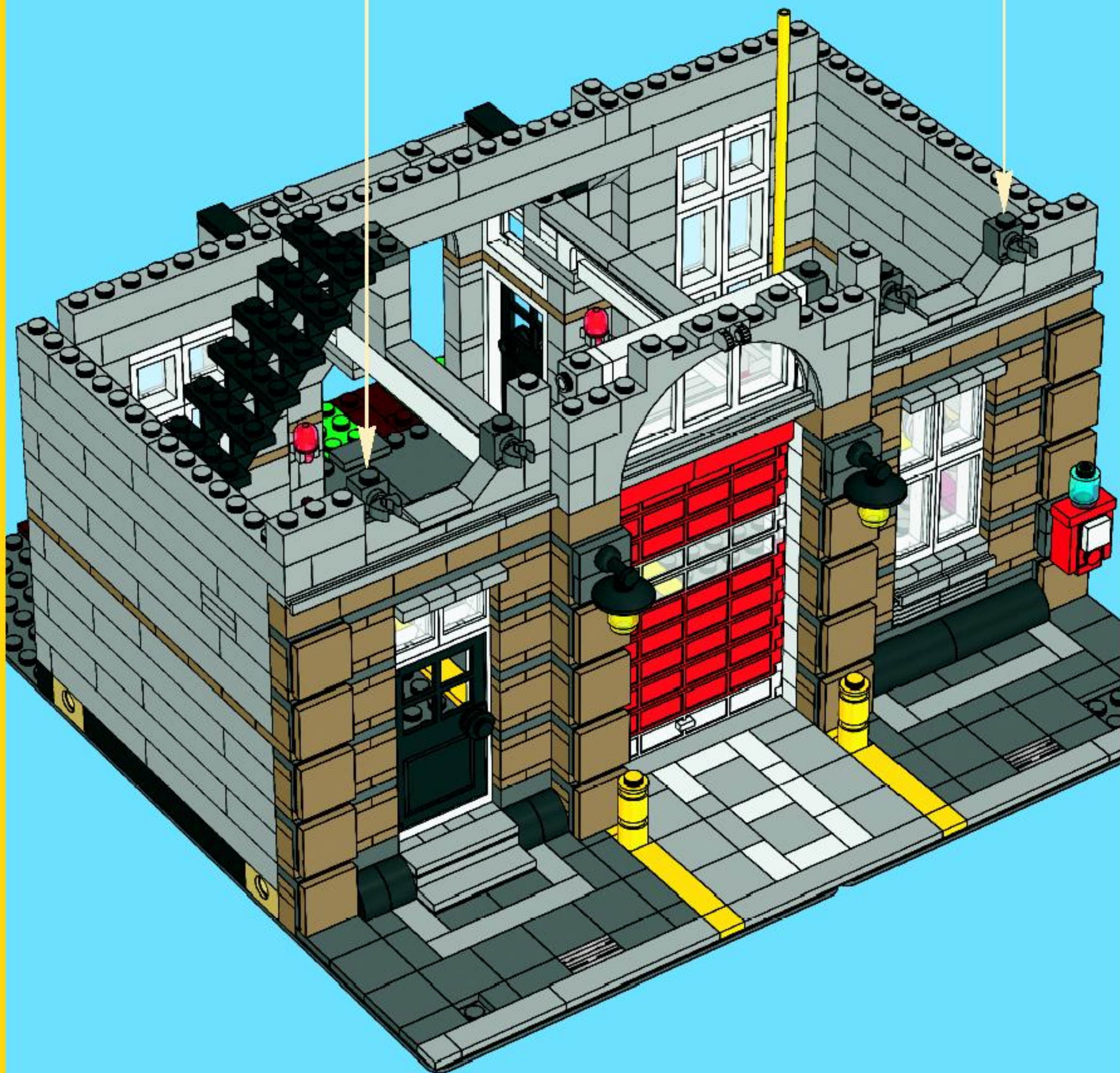
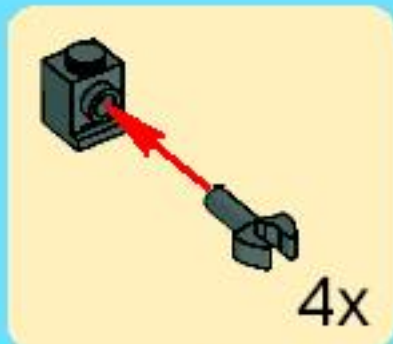

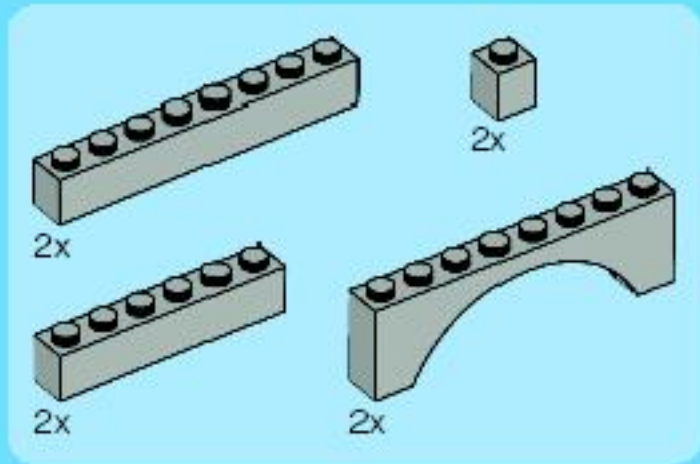

49

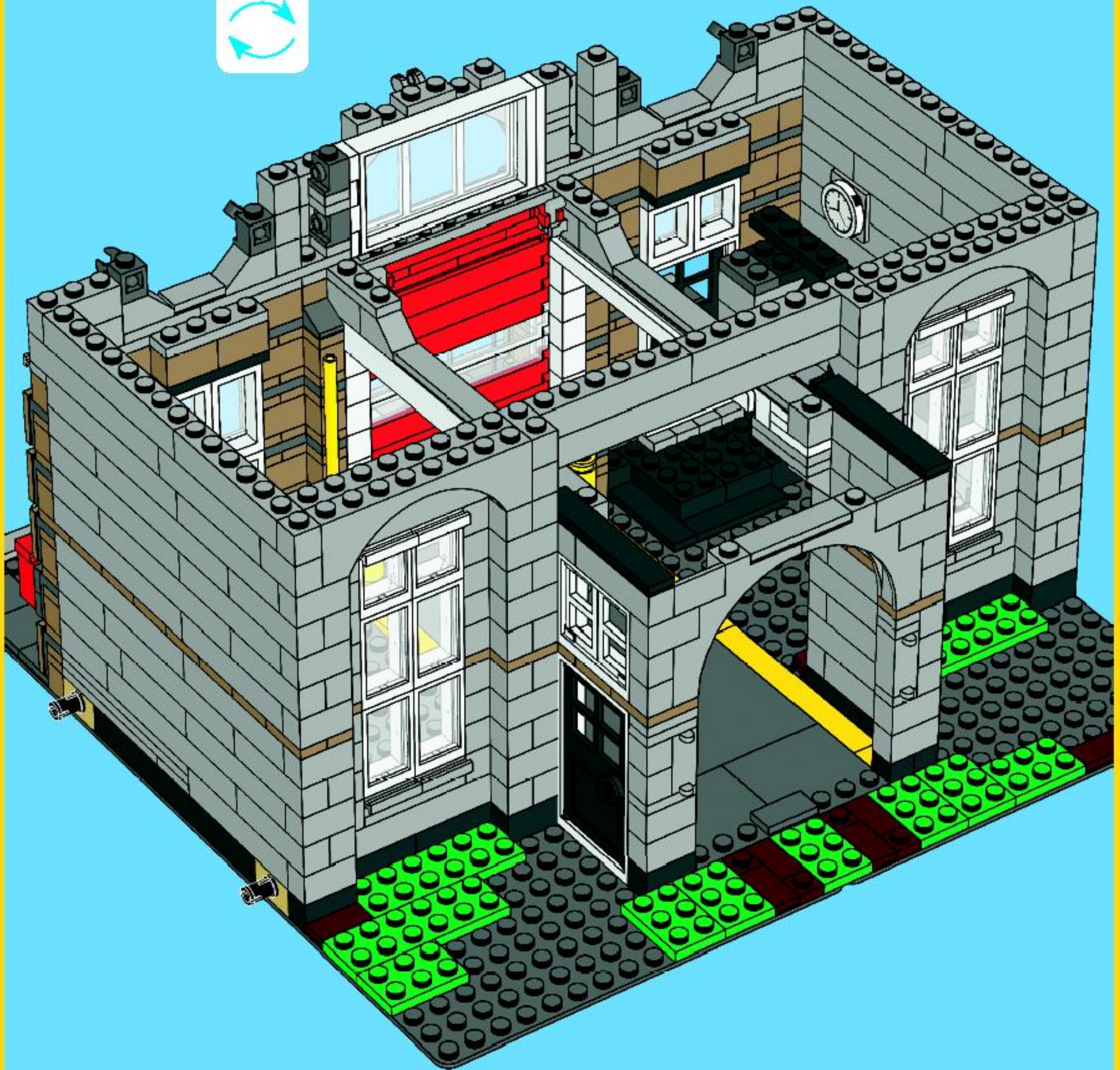

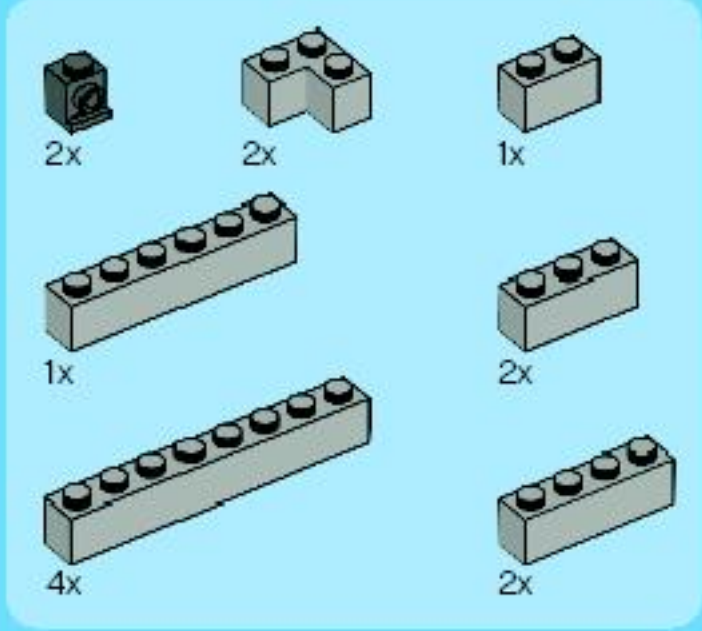

50

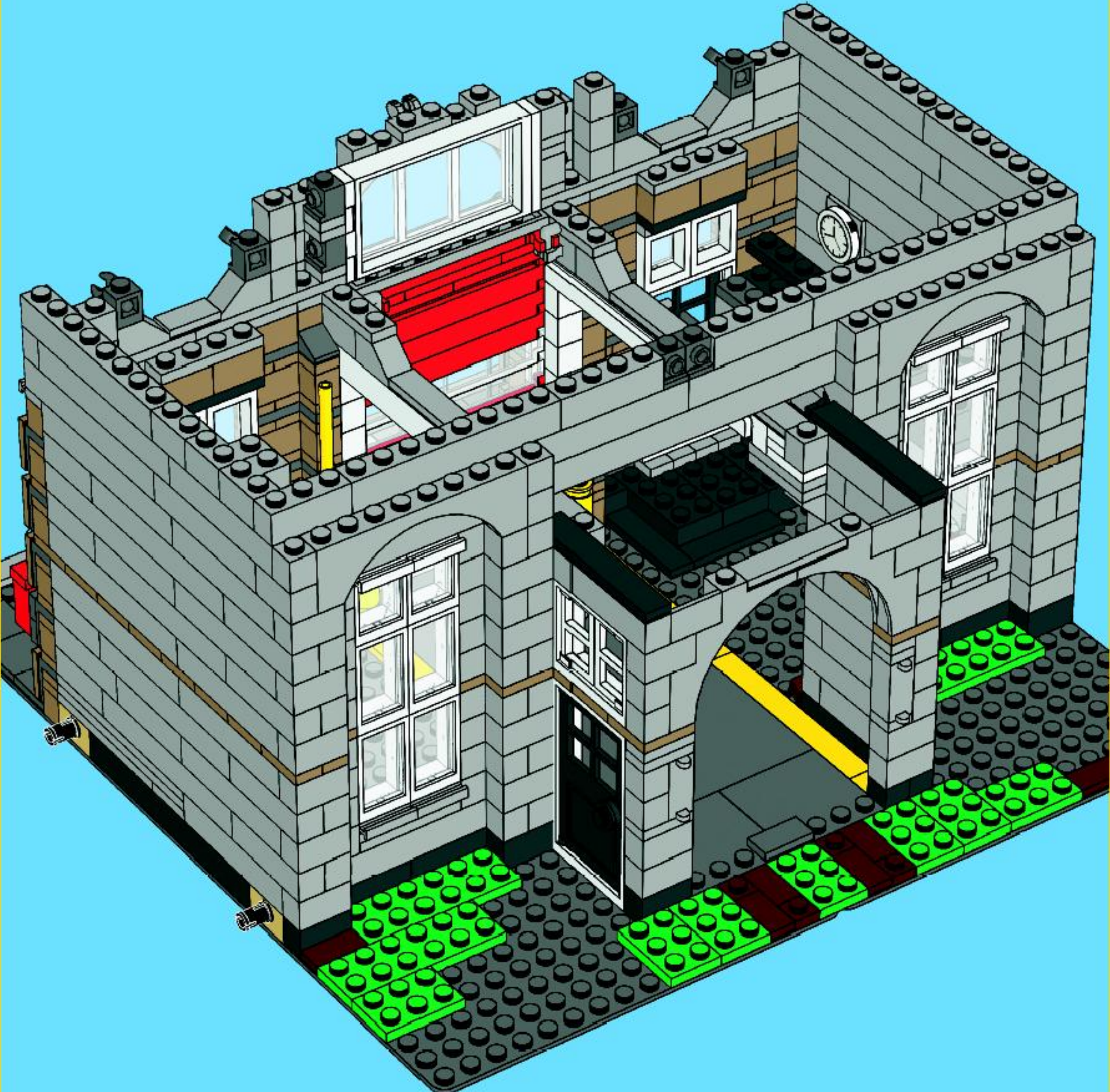

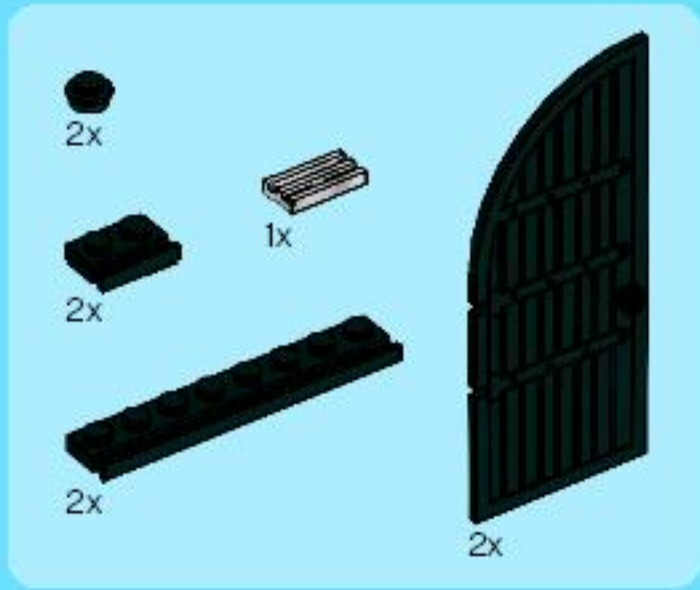

51

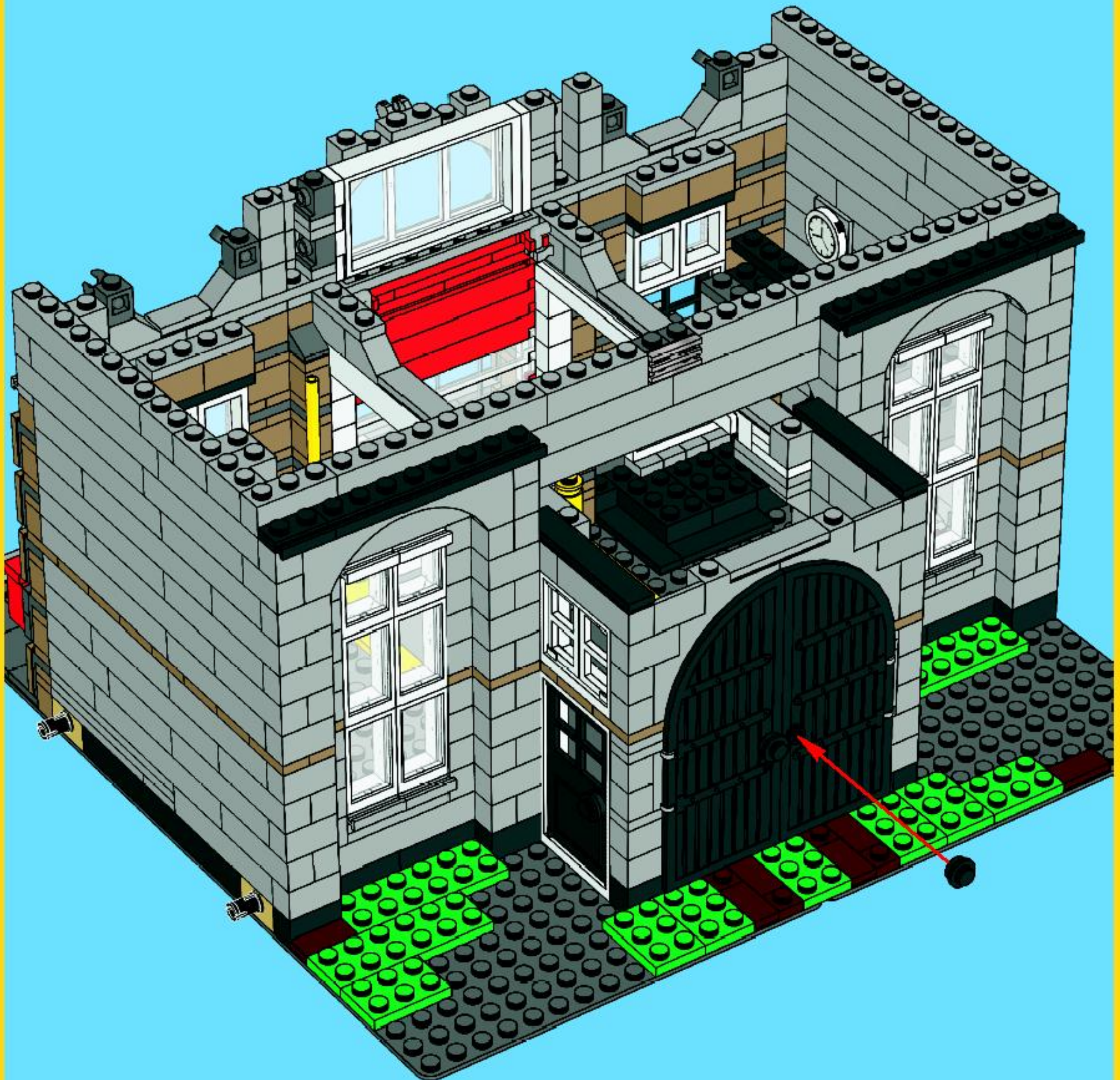

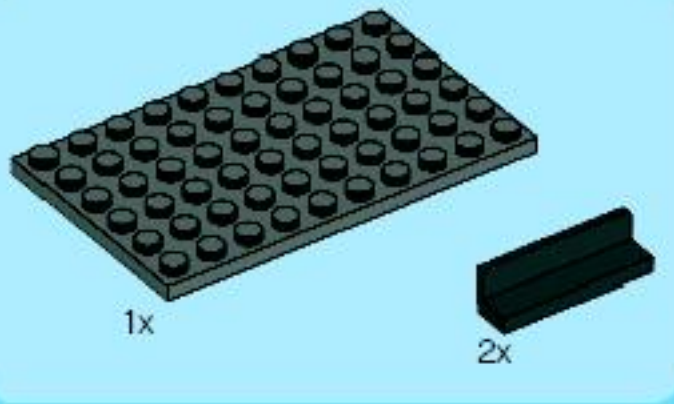

1

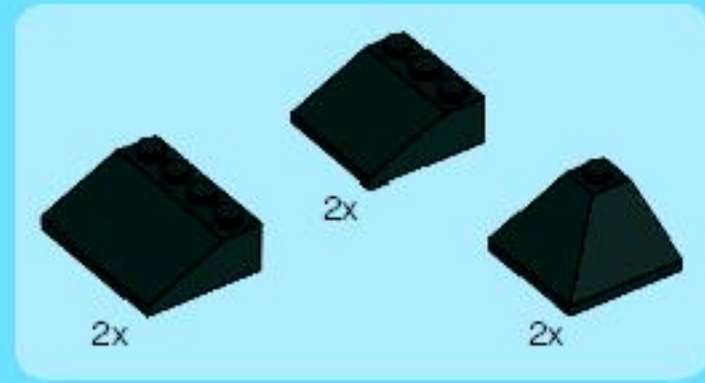
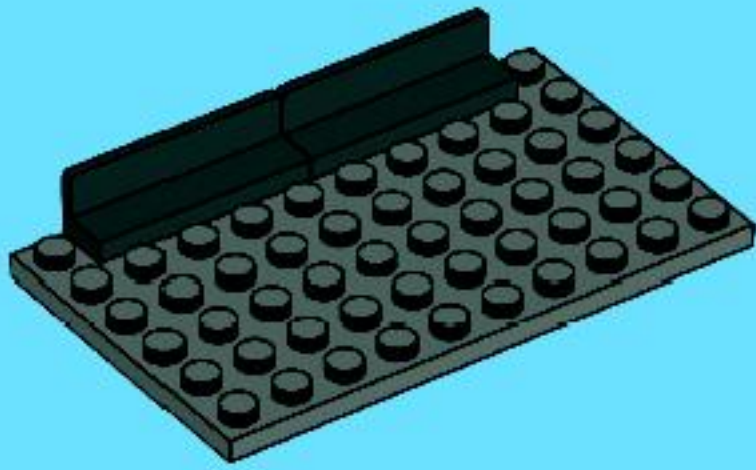

3

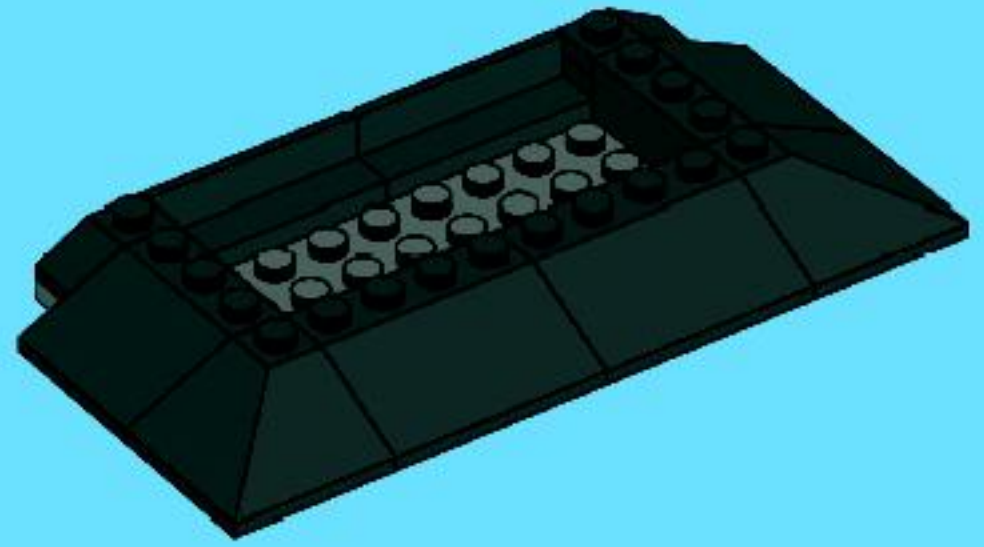

2

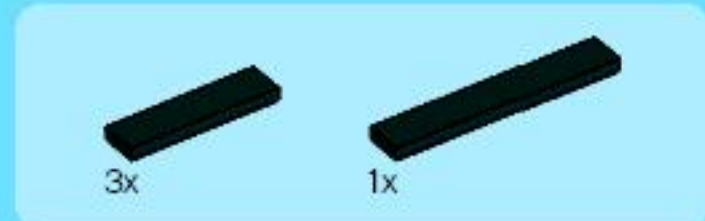
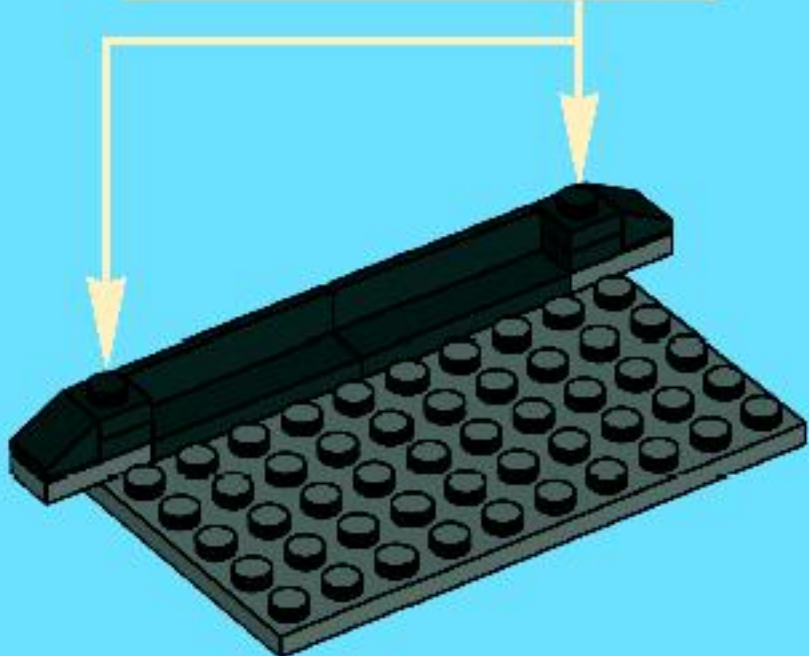
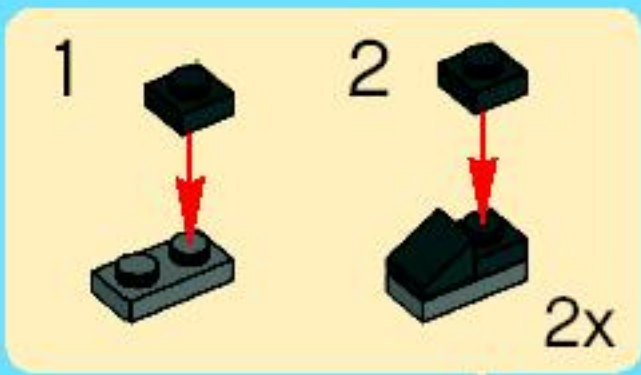

4

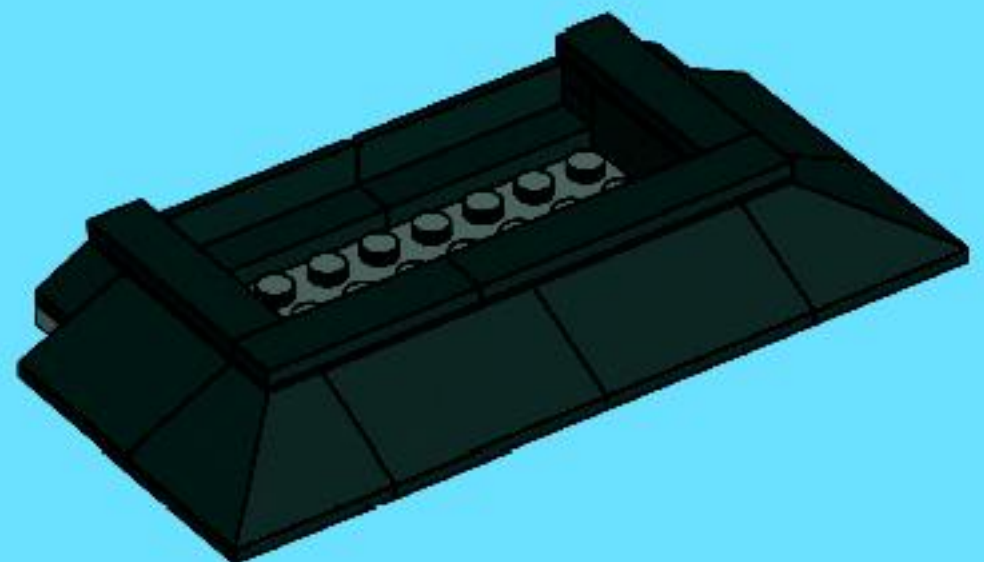

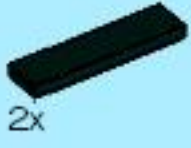

52

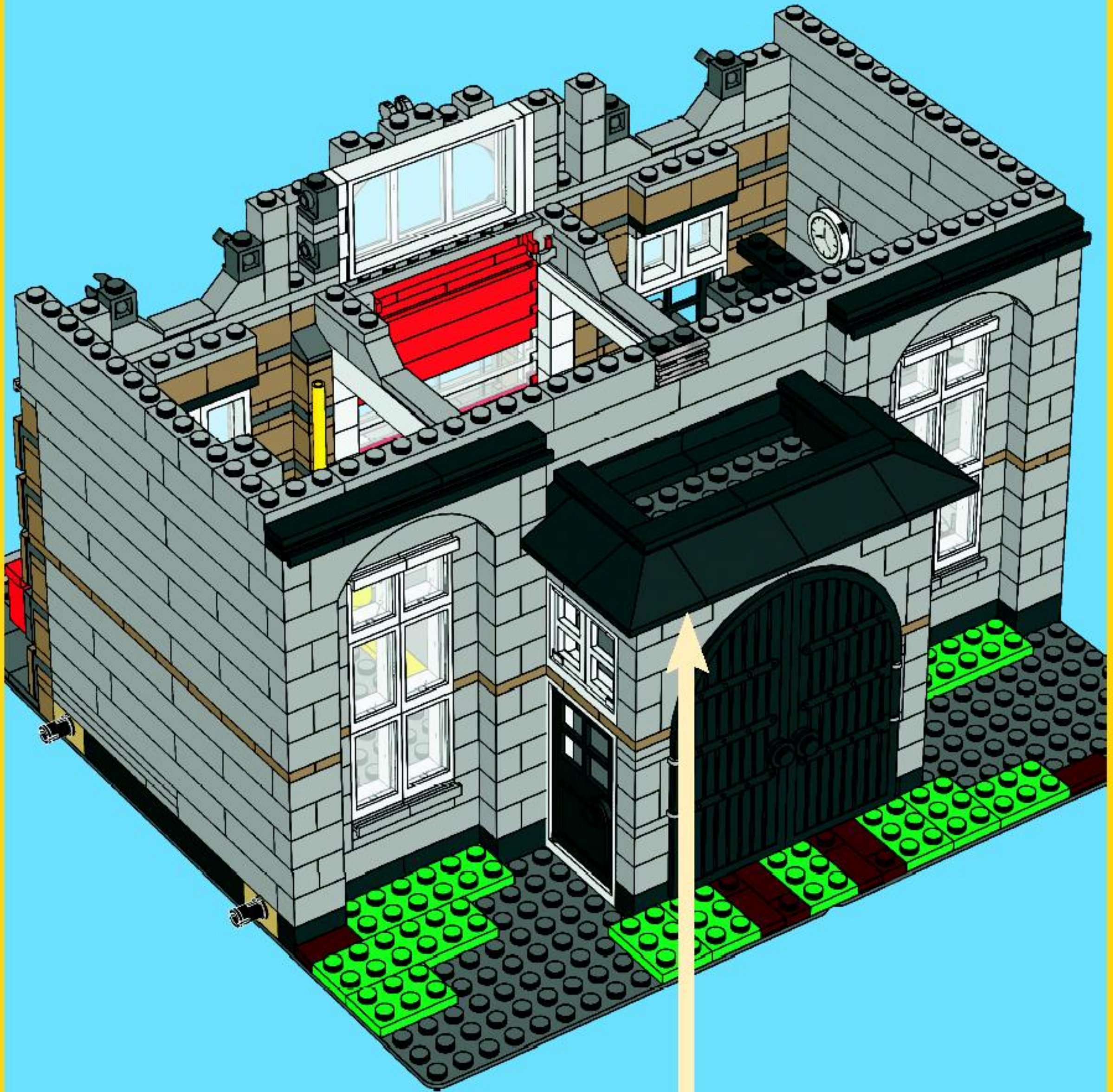

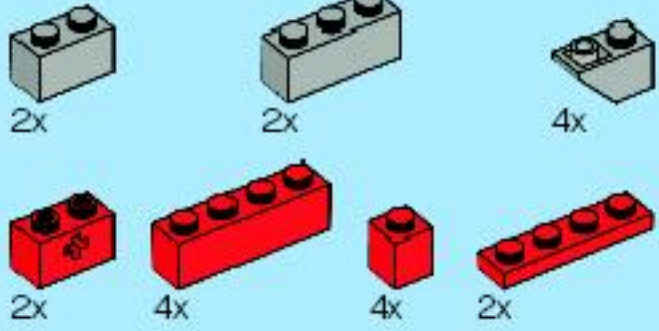

53

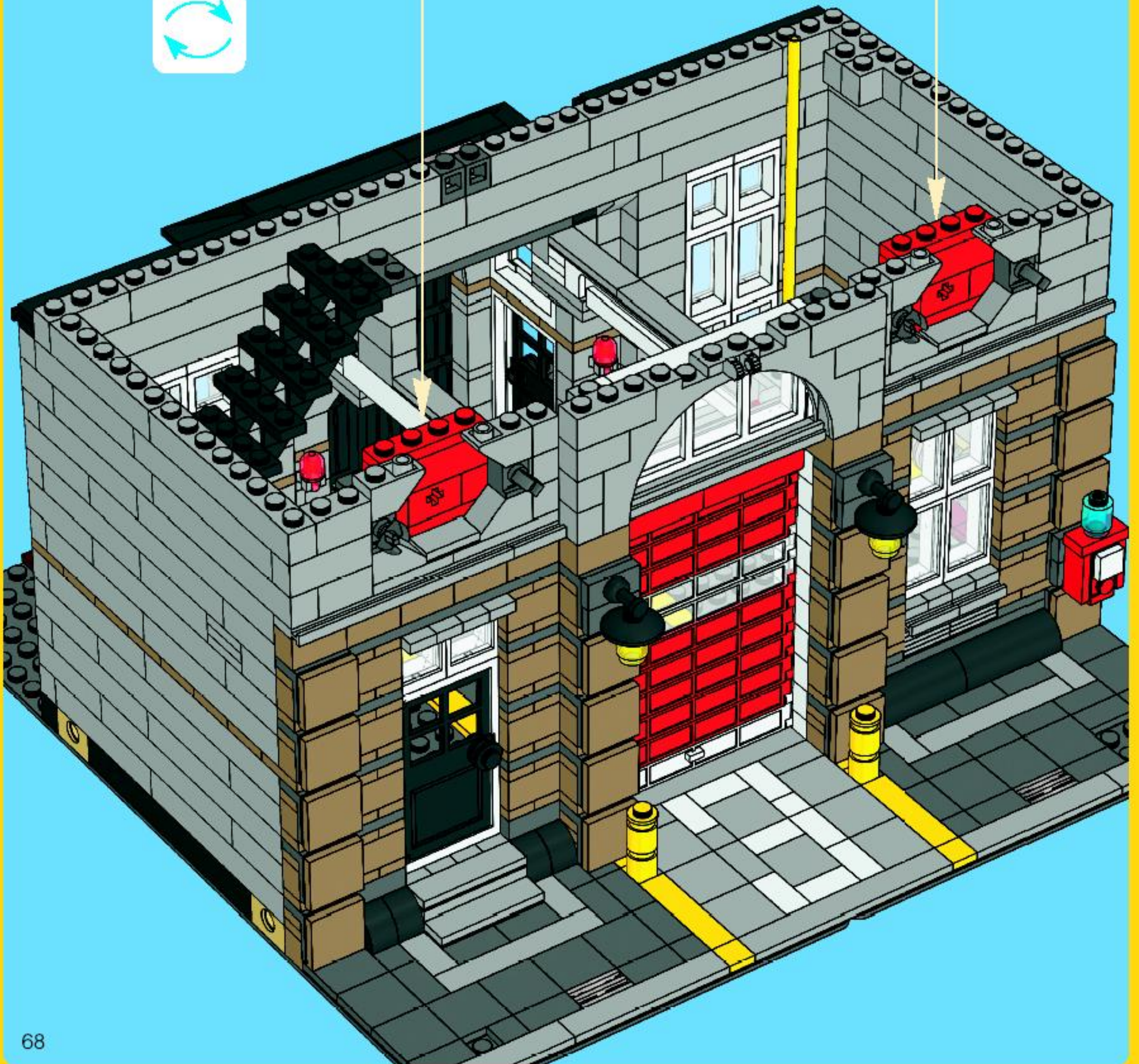
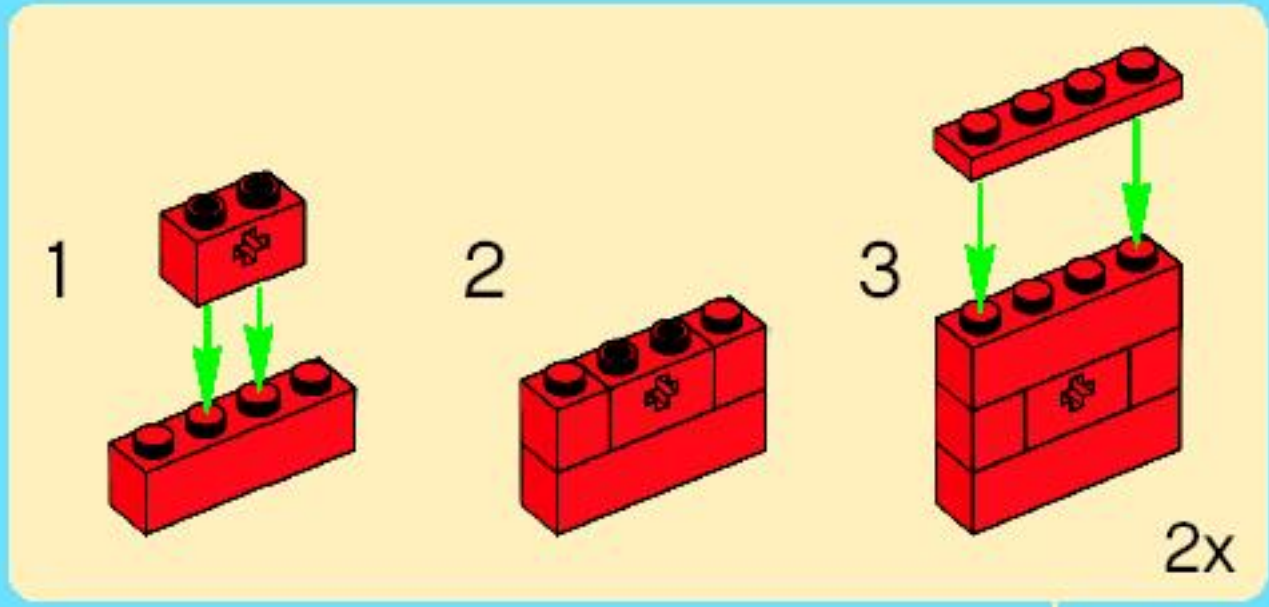

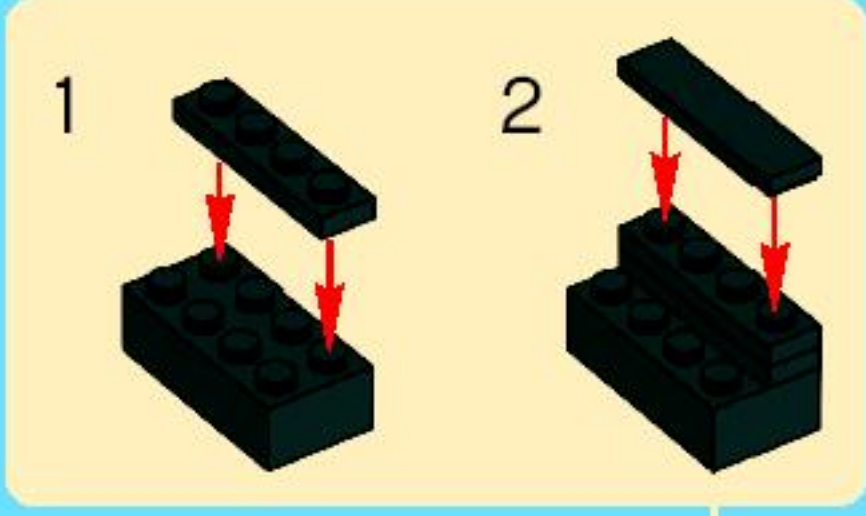
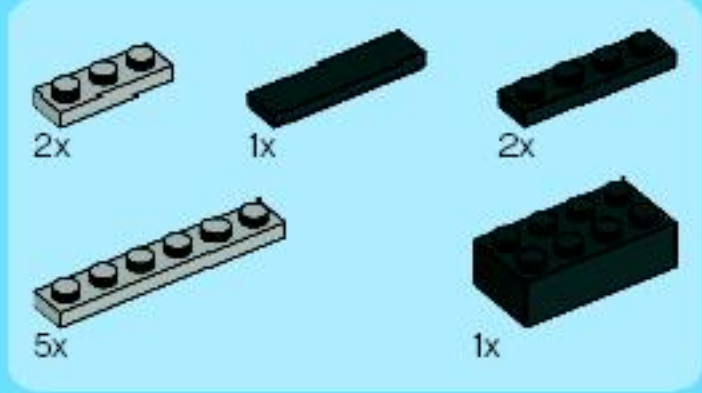

54

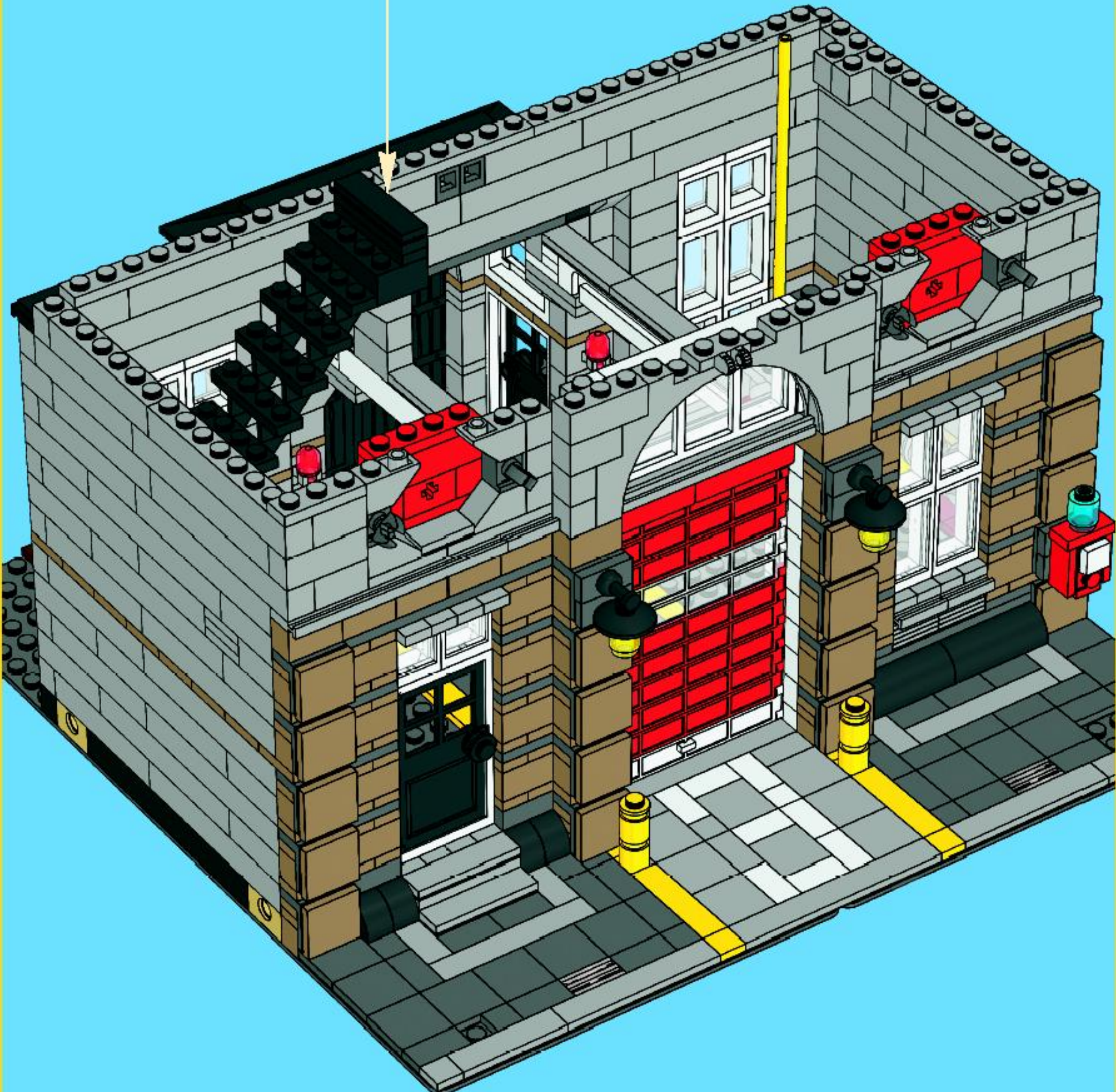

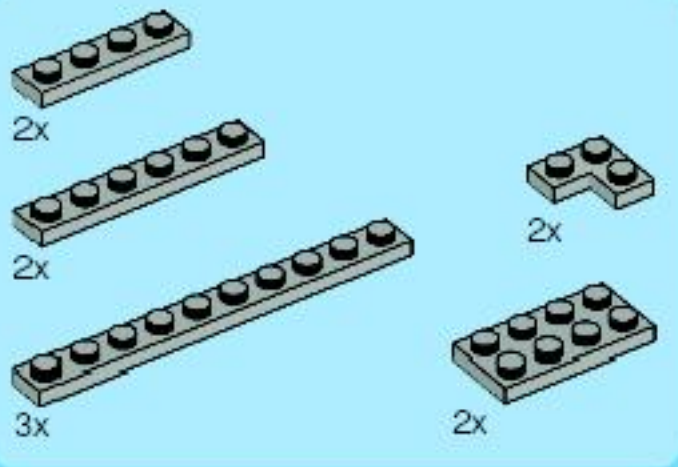

55

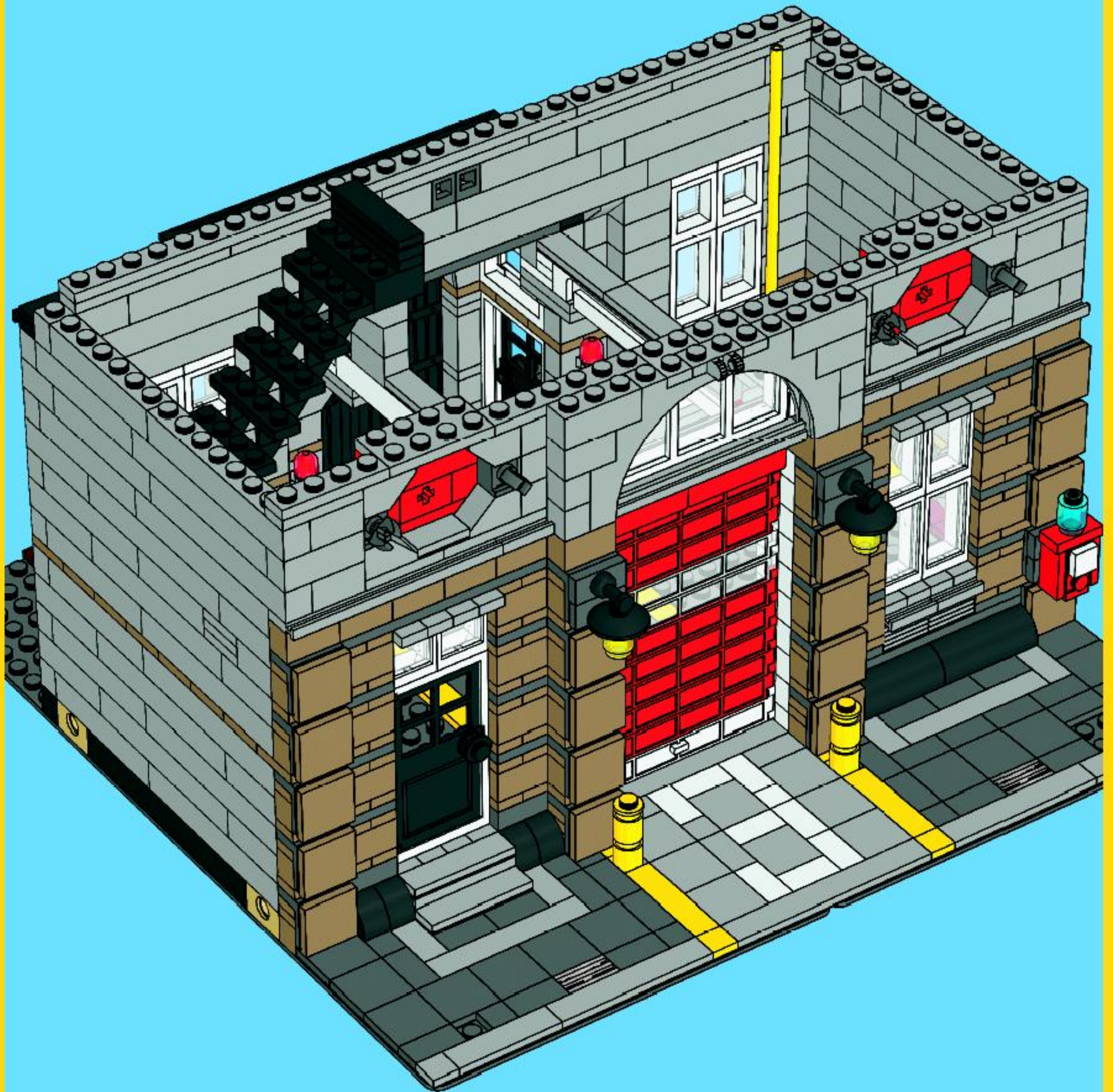

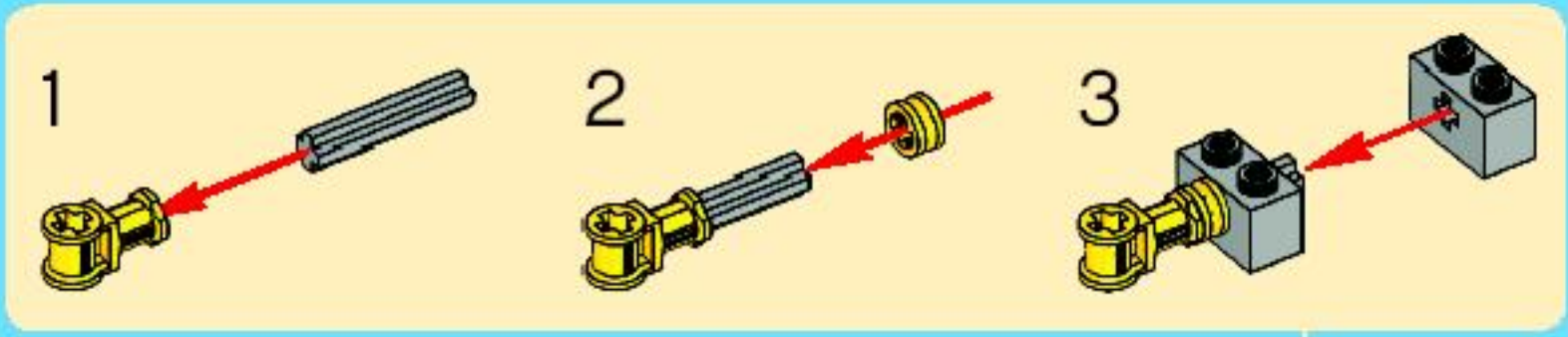
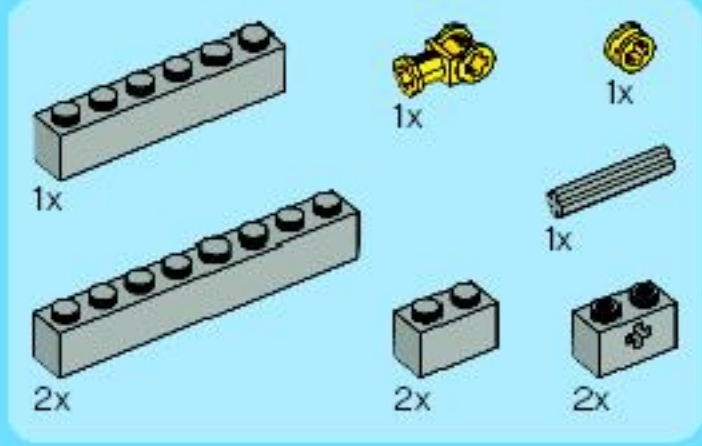

56

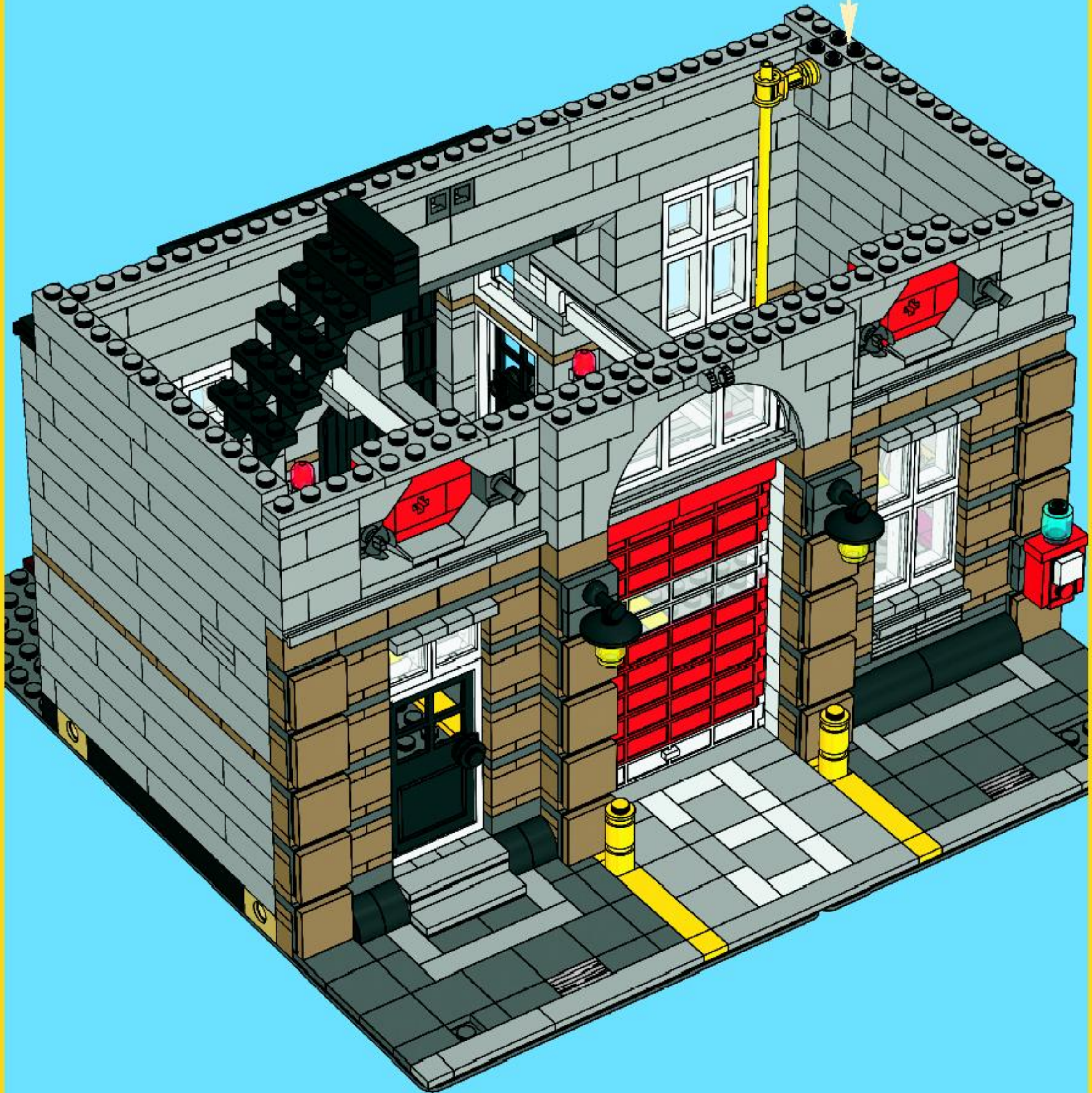

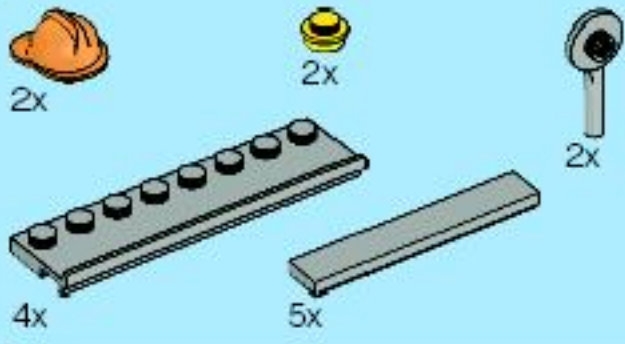

57

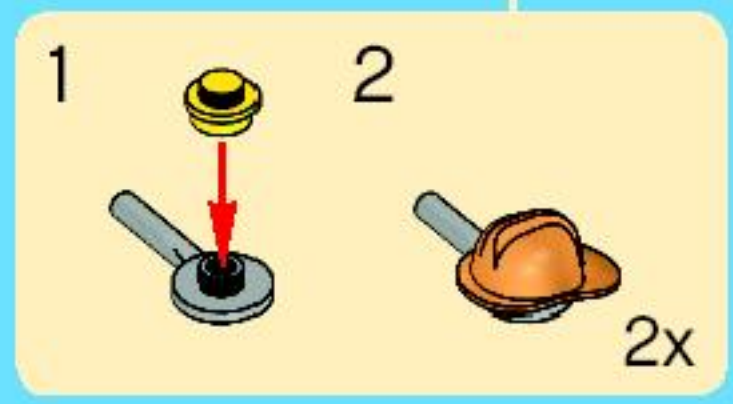
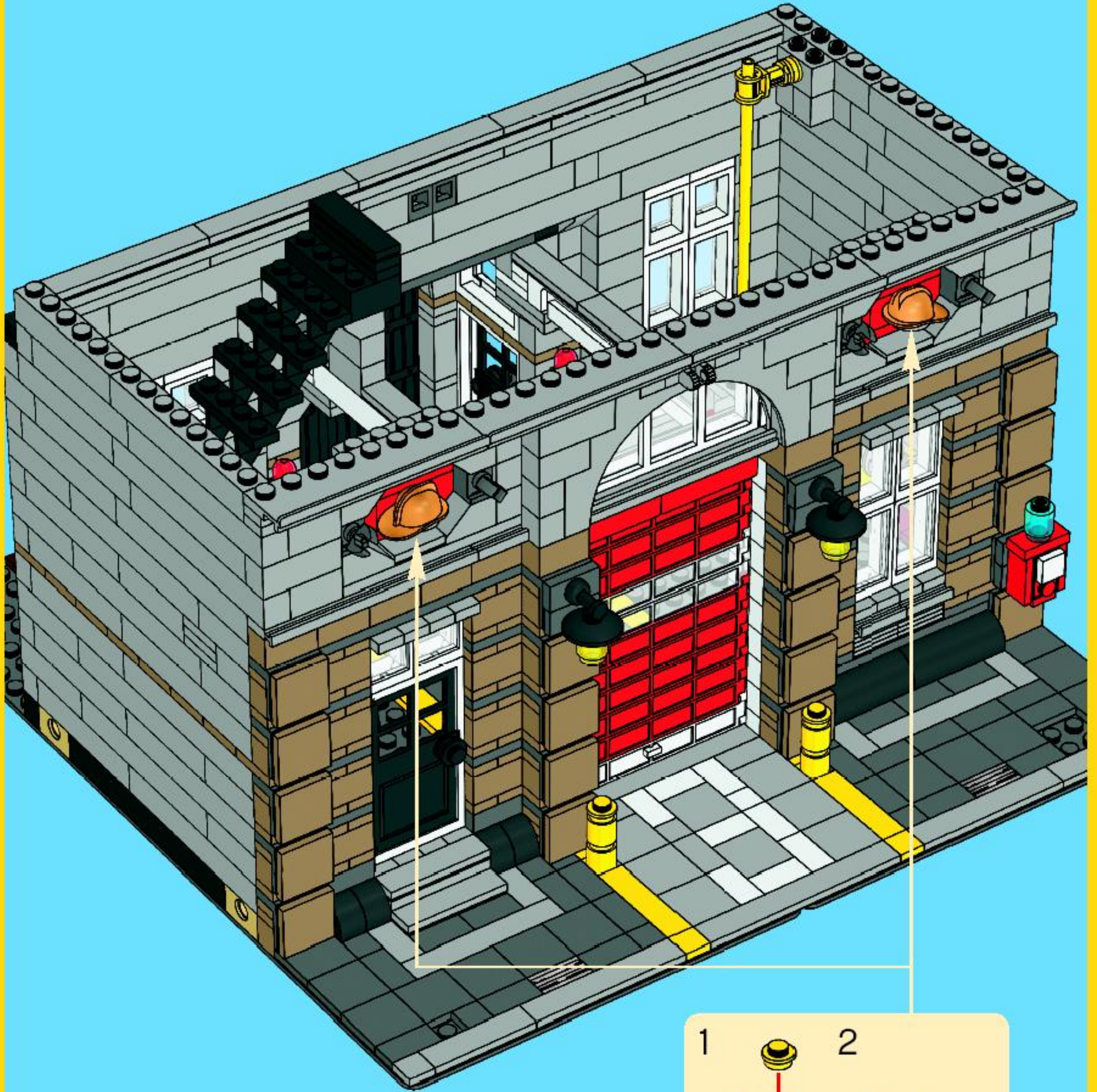

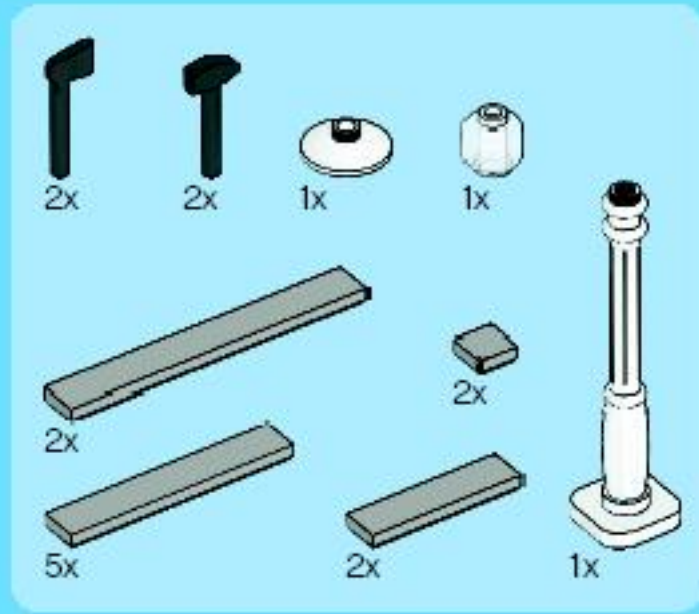

58

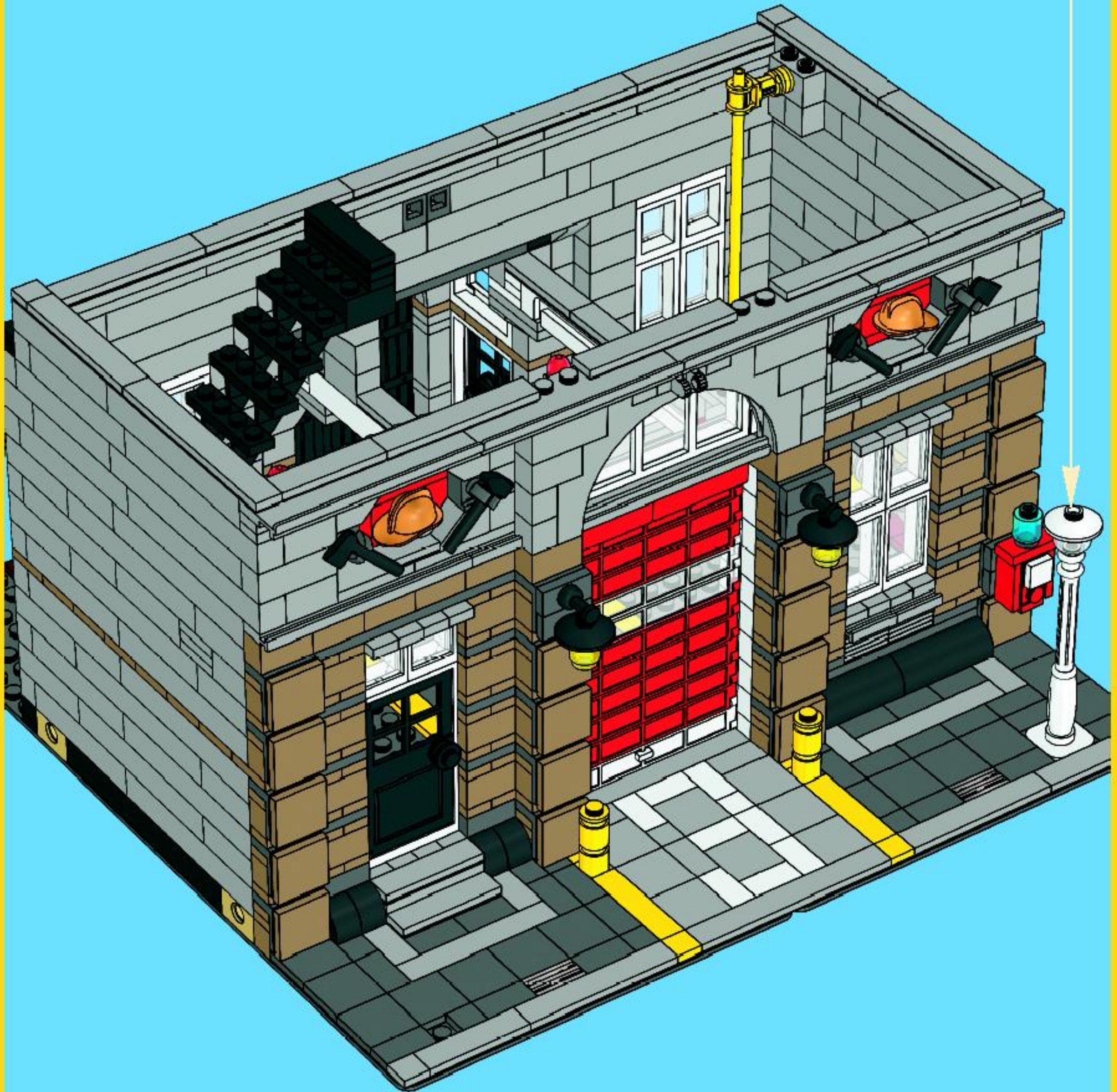
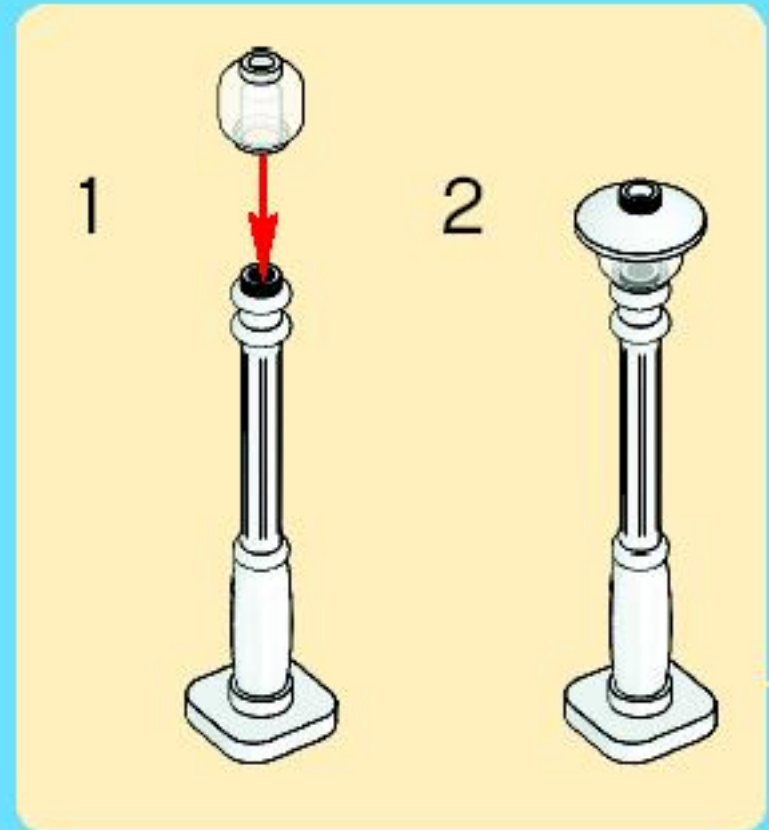

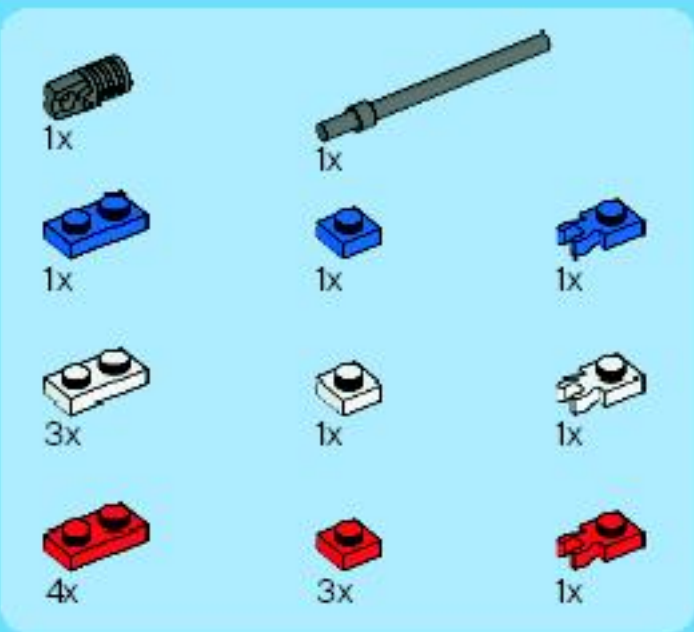

59

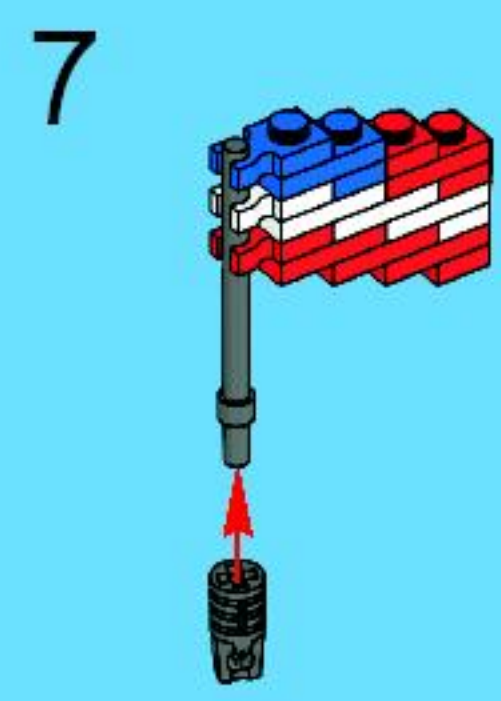
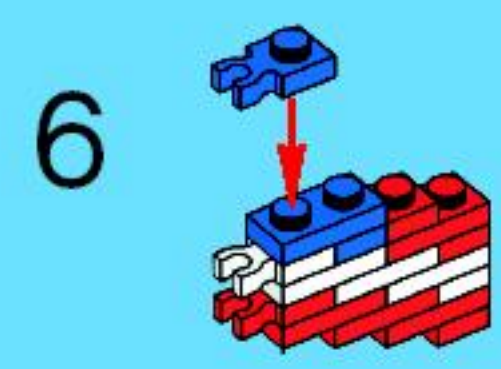
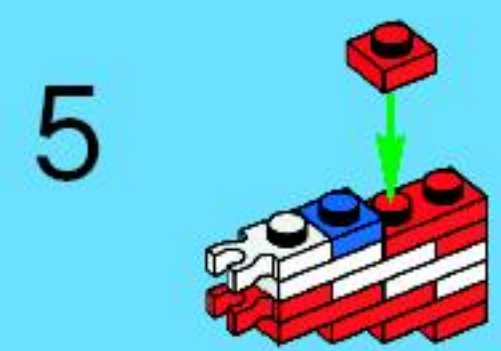
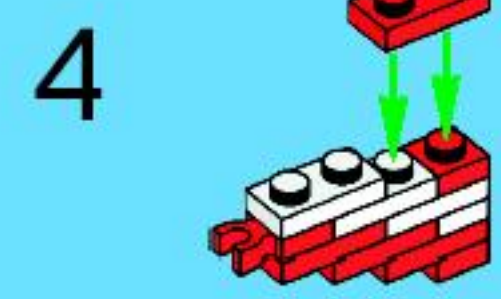
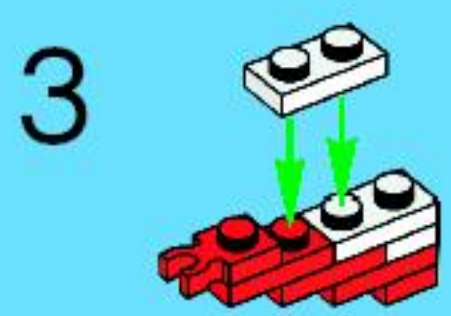
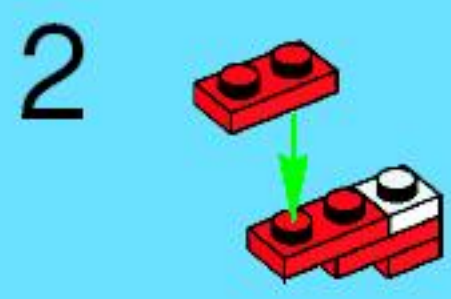
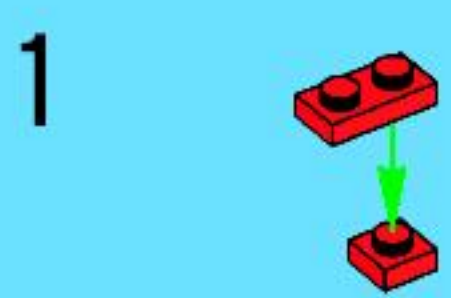

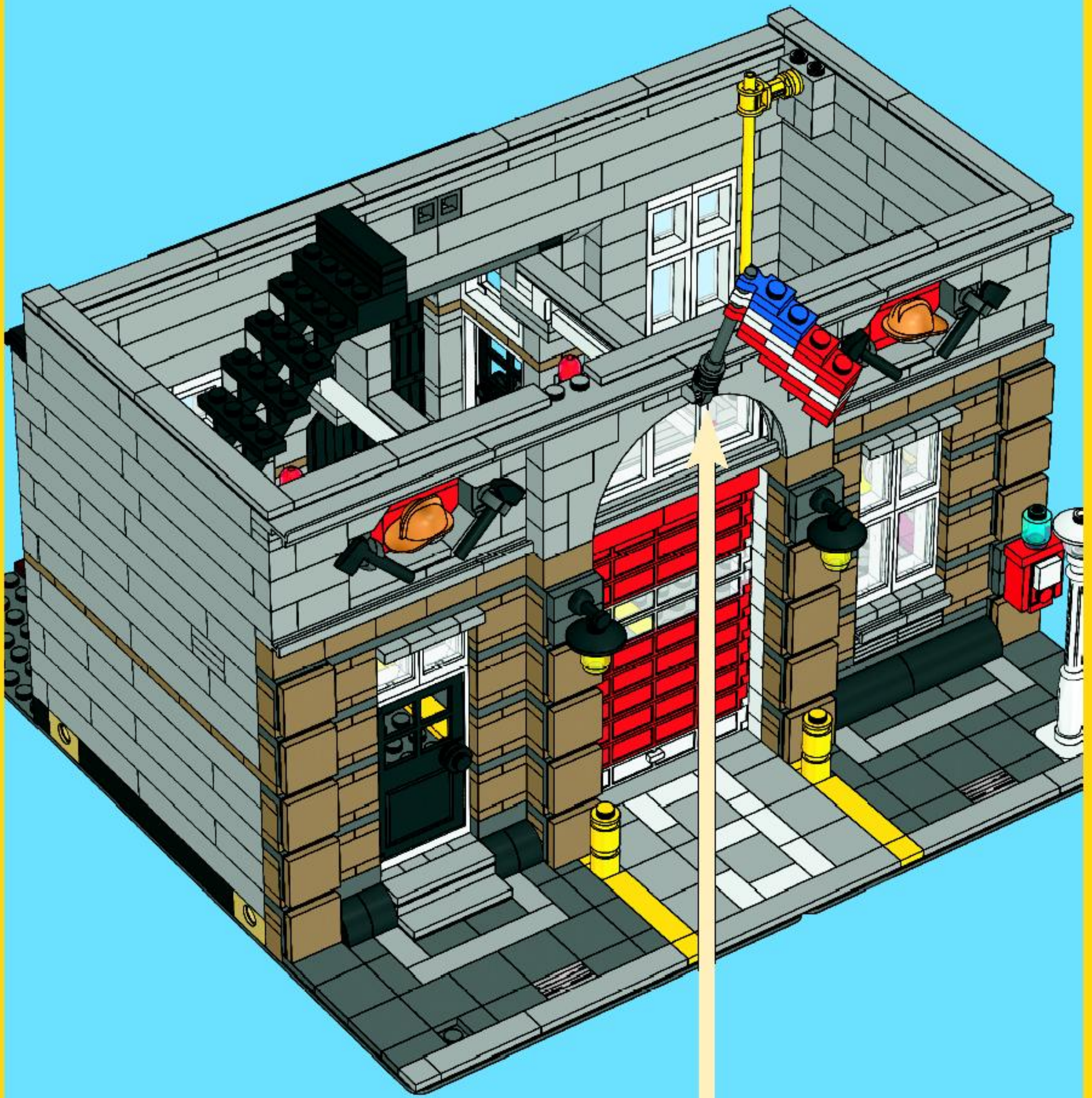



60

1



2



3



4



5

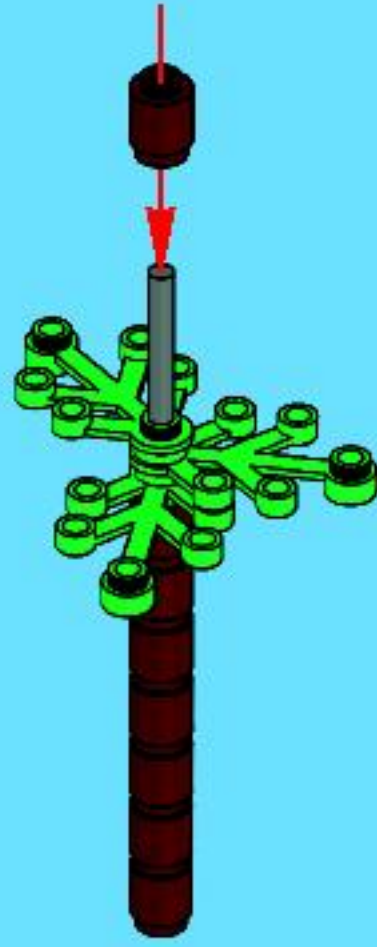

6

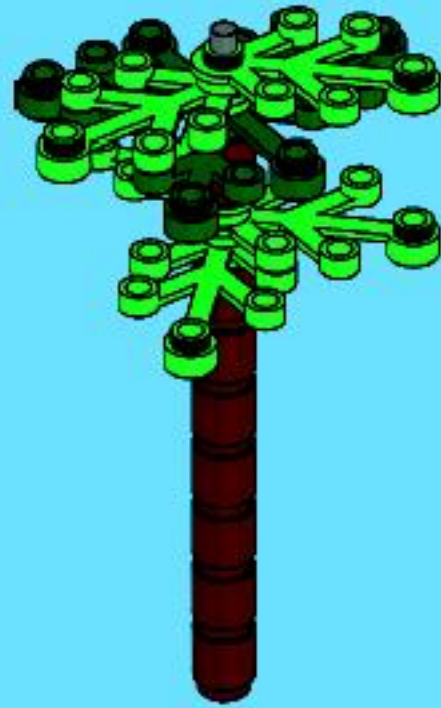

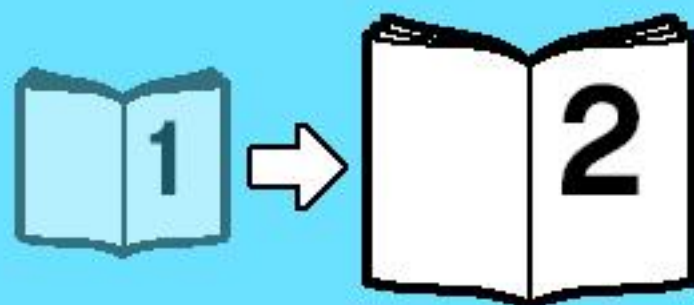
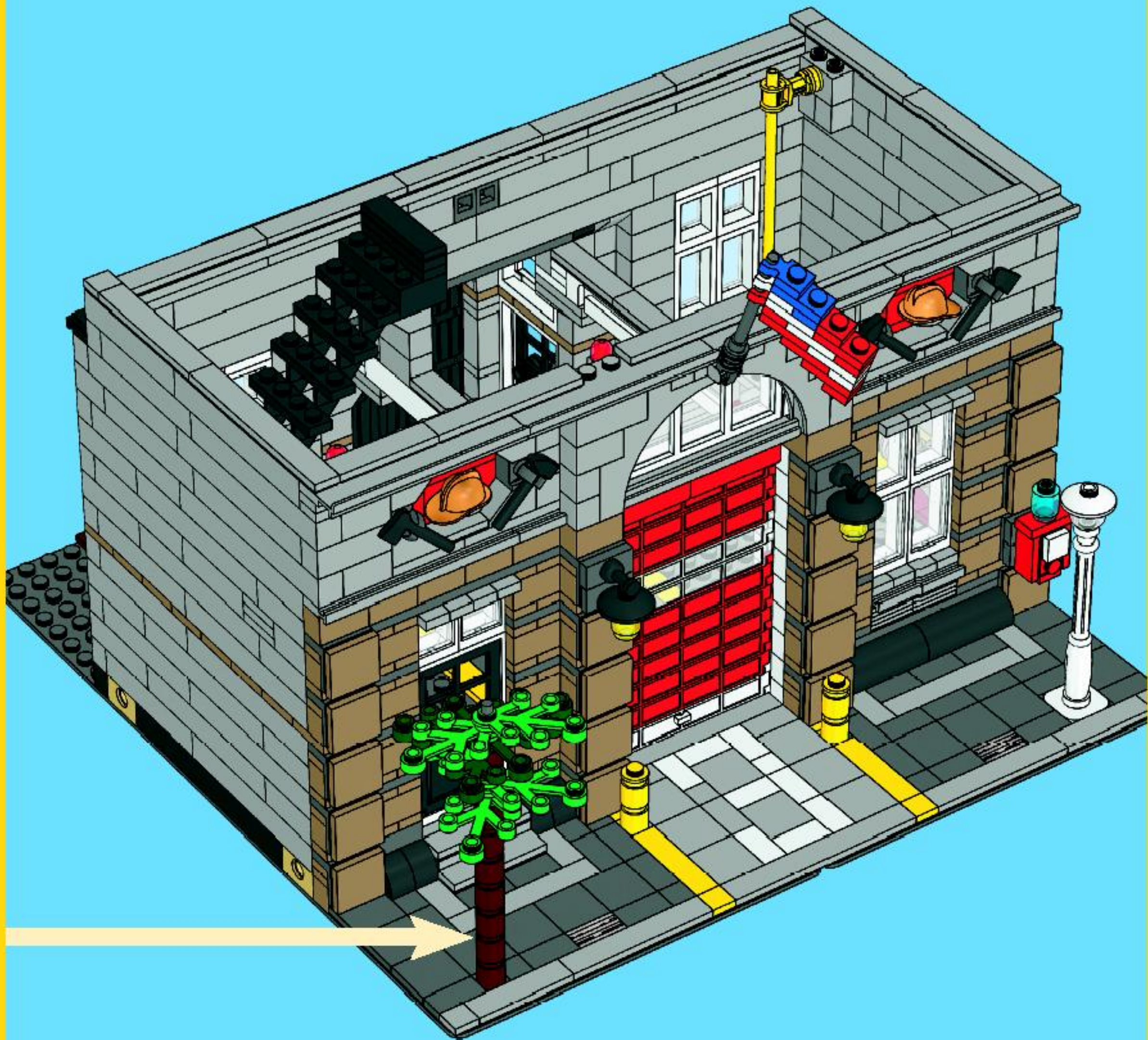



10132

10185

10197

10196





10194

10193





STAR WARS

II



10195



LEGO, the LEGO logo and the Minifigure are trademarks of the/son des marques de commerce de/son marcas registradas de LEGO Group. ©2009 The LEGO Group ©2009 Lucasfilm Ltd. & TM. All rights reserved. Used under authorization/Tous droits réservés. Utilisé sous autorisation/Todos los derechos reservados. Usado bajo autorización.



STAR WARS



10198



LEGO, the LEGO logo and the Minifigure are trademarks of the/son des marques de commerce de/son marcas registradas de LEGO Group. ©2009 The LEGO Group. ©2009 Lucasfilm Ltd. & TM. All rights reserved. Used under authorization/Tous droits réservés. Utilisé sous autorisation/Todos los derechos reservados. Usado bajo autorización.



©2009 The LEGO Group. 45 65 201



FIRE BRIGADE
LA BRIGADE DE FEU

10197



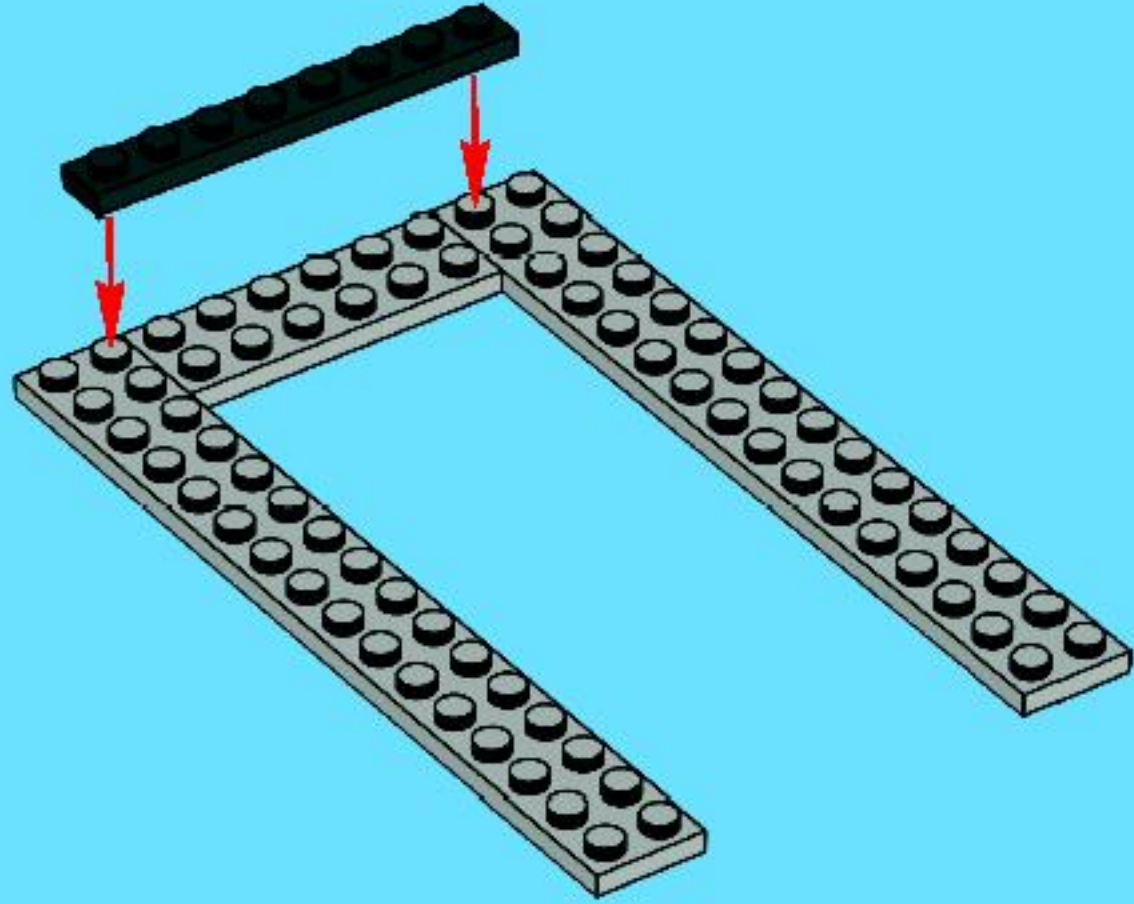
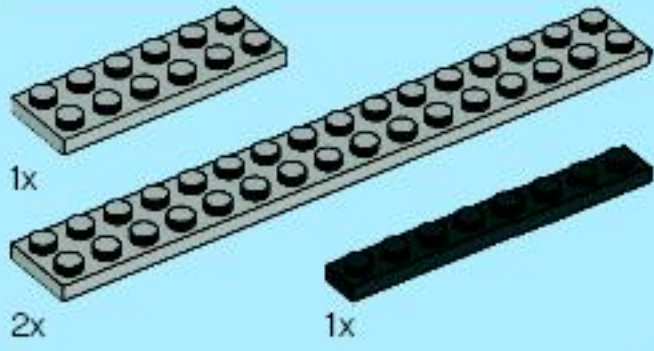

1

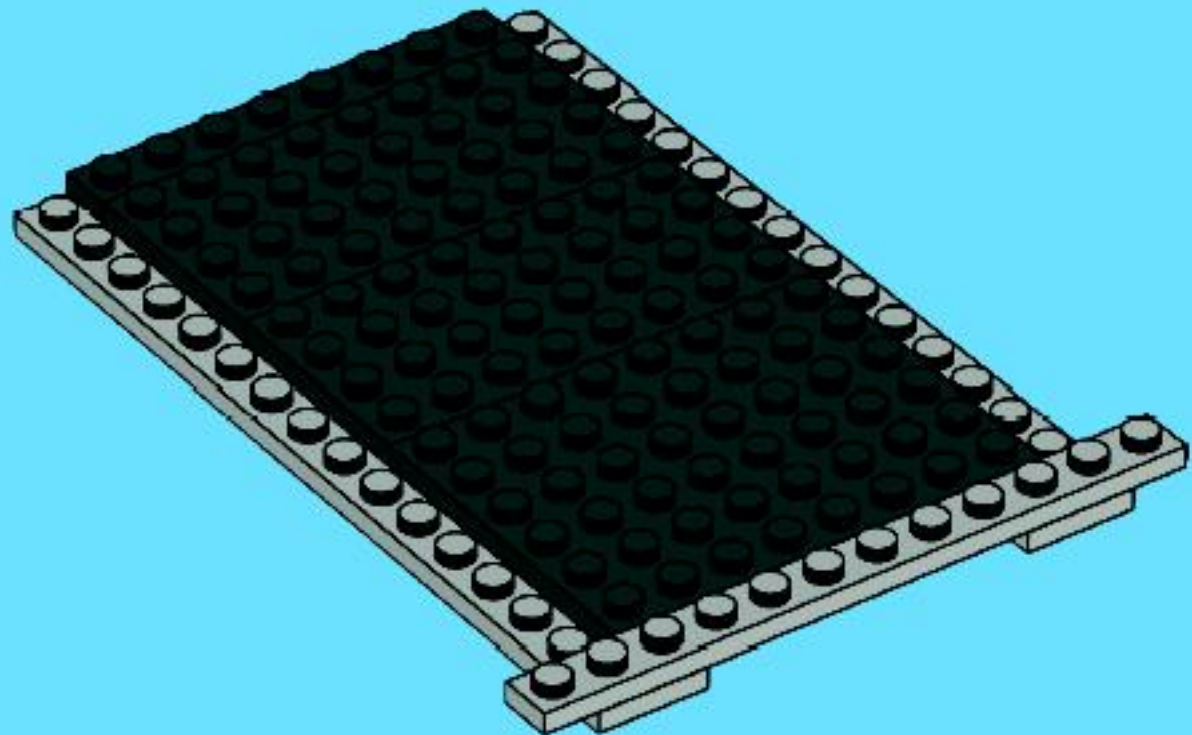
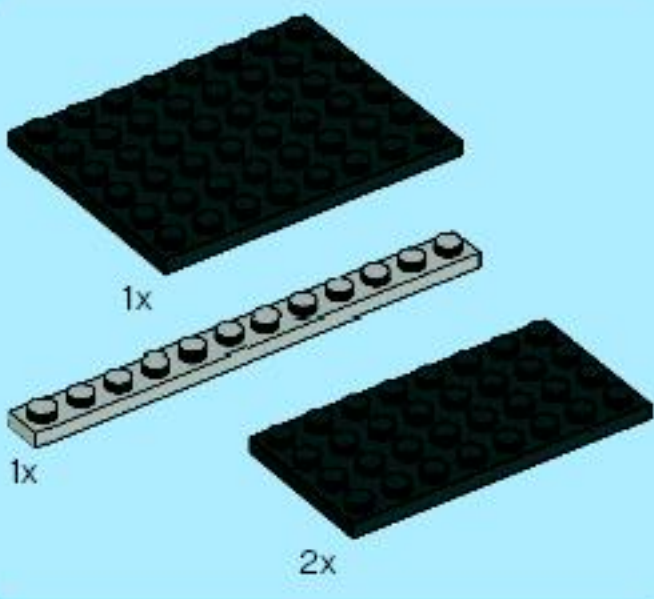

2

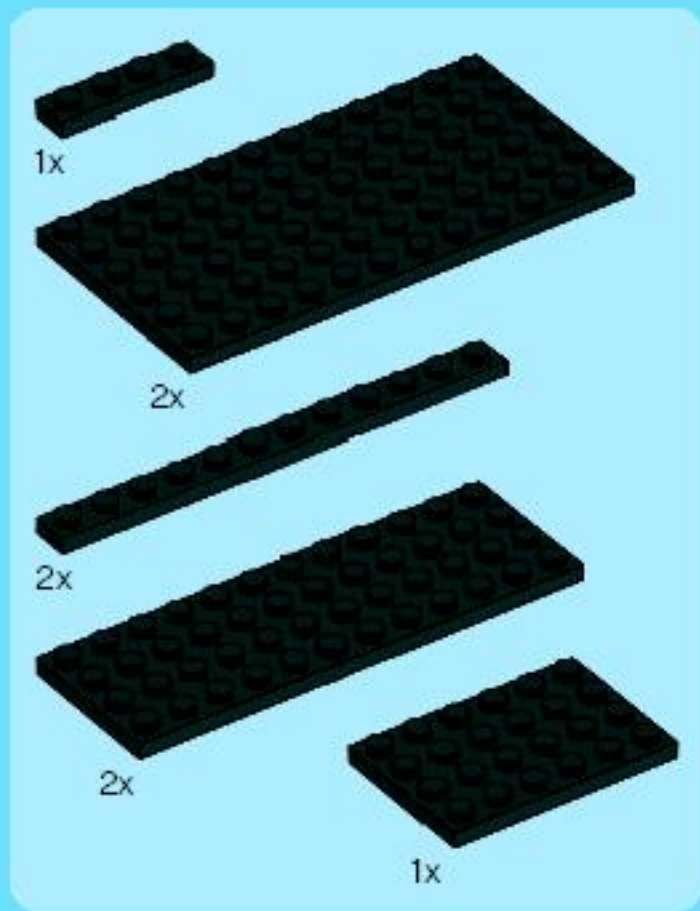

3

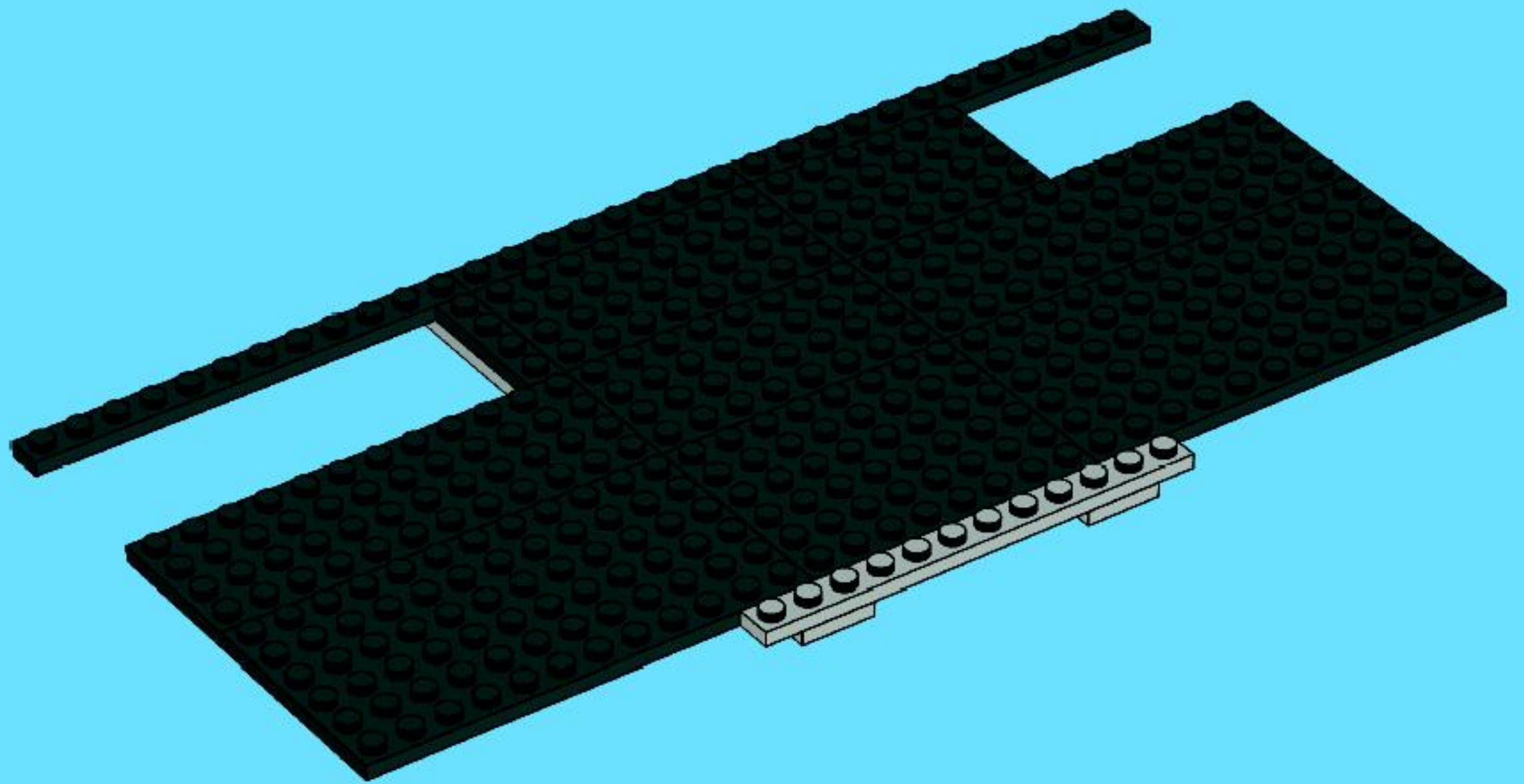

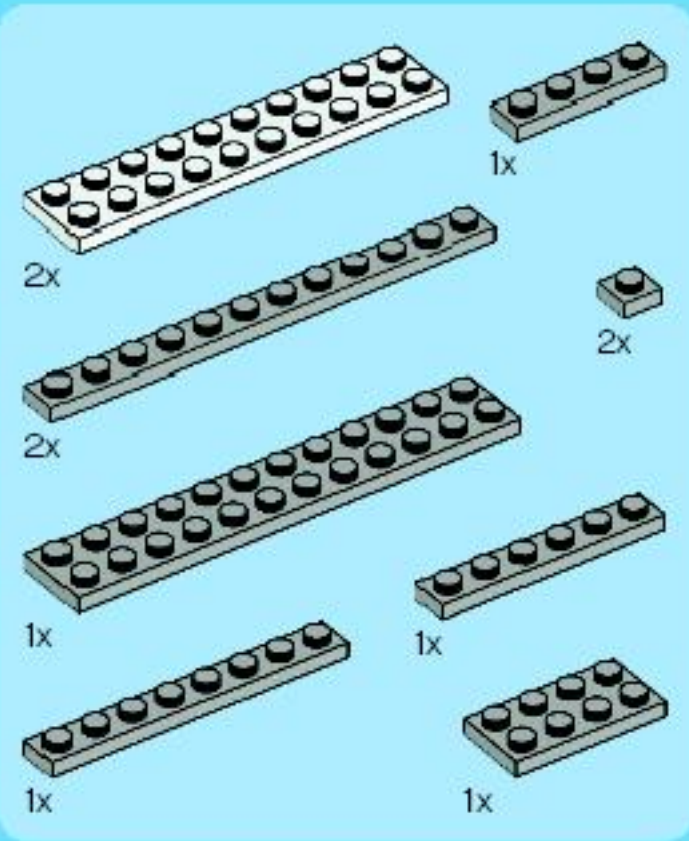

4

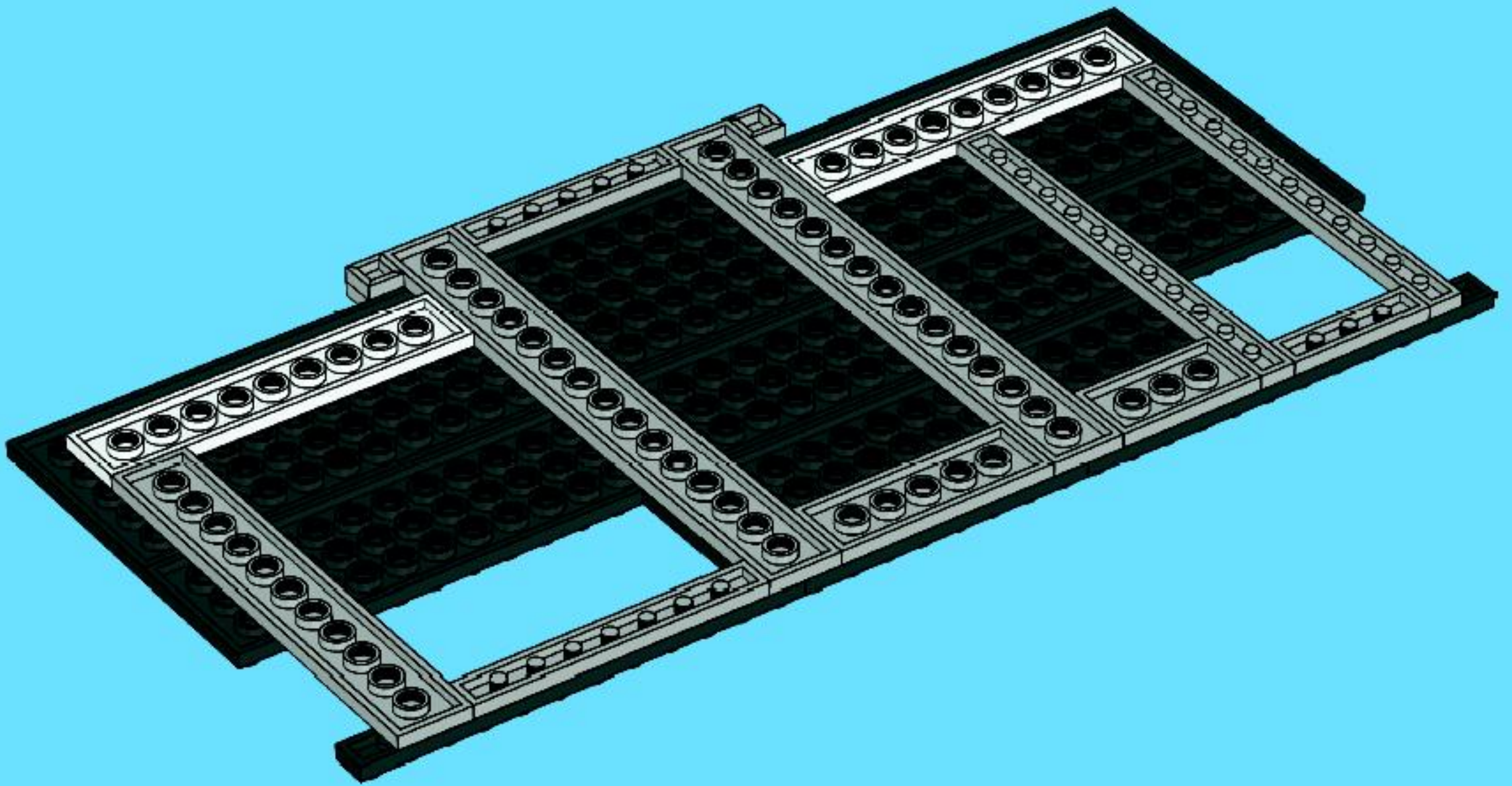

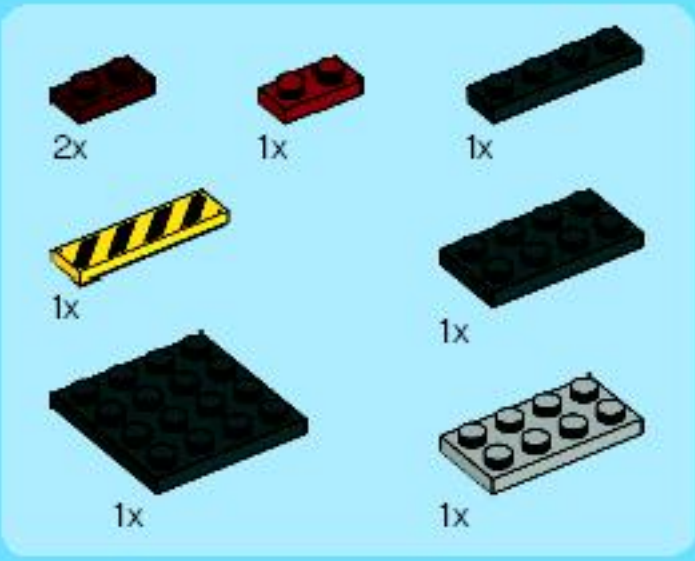

5

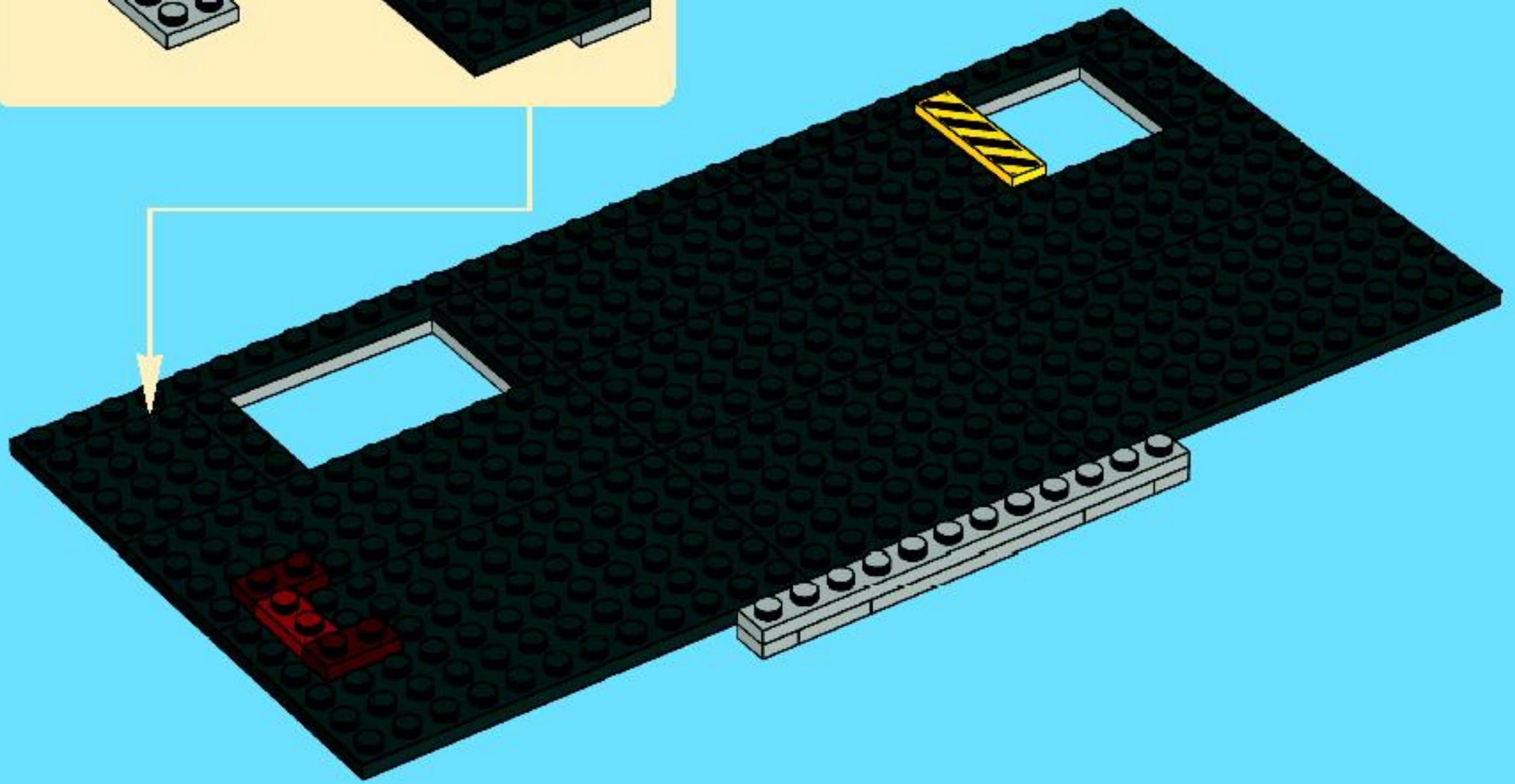
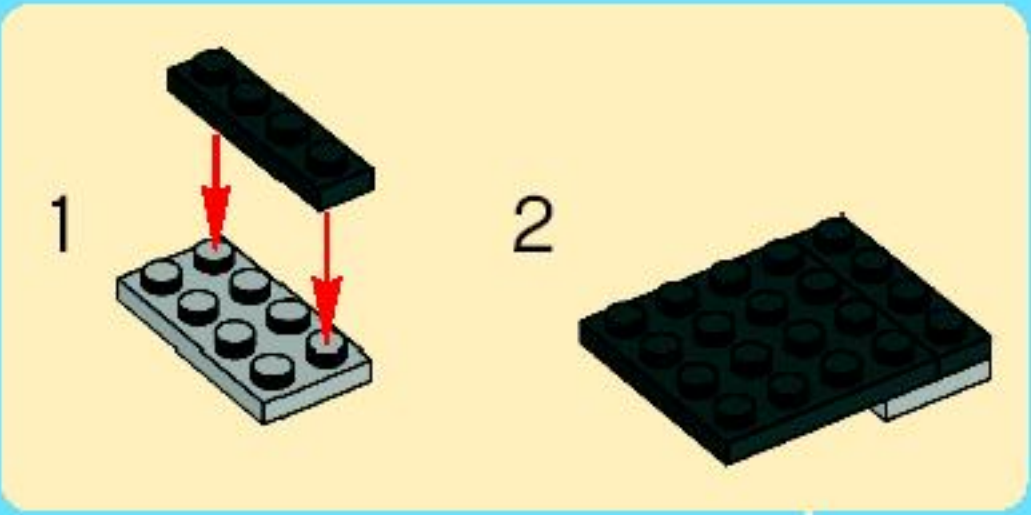

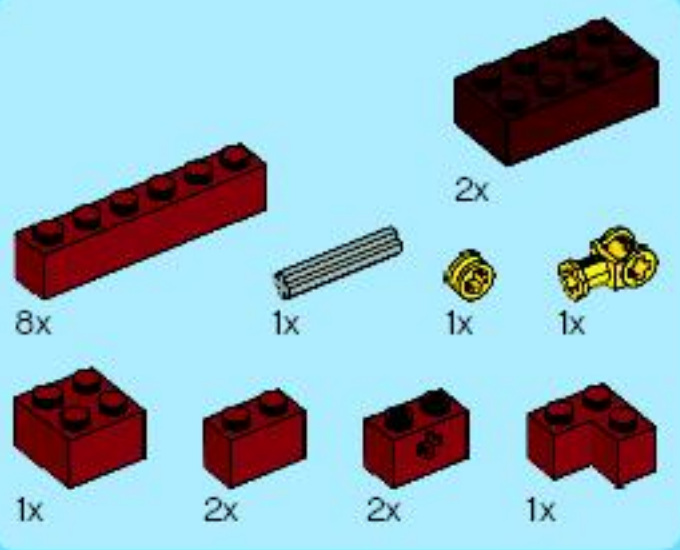

6

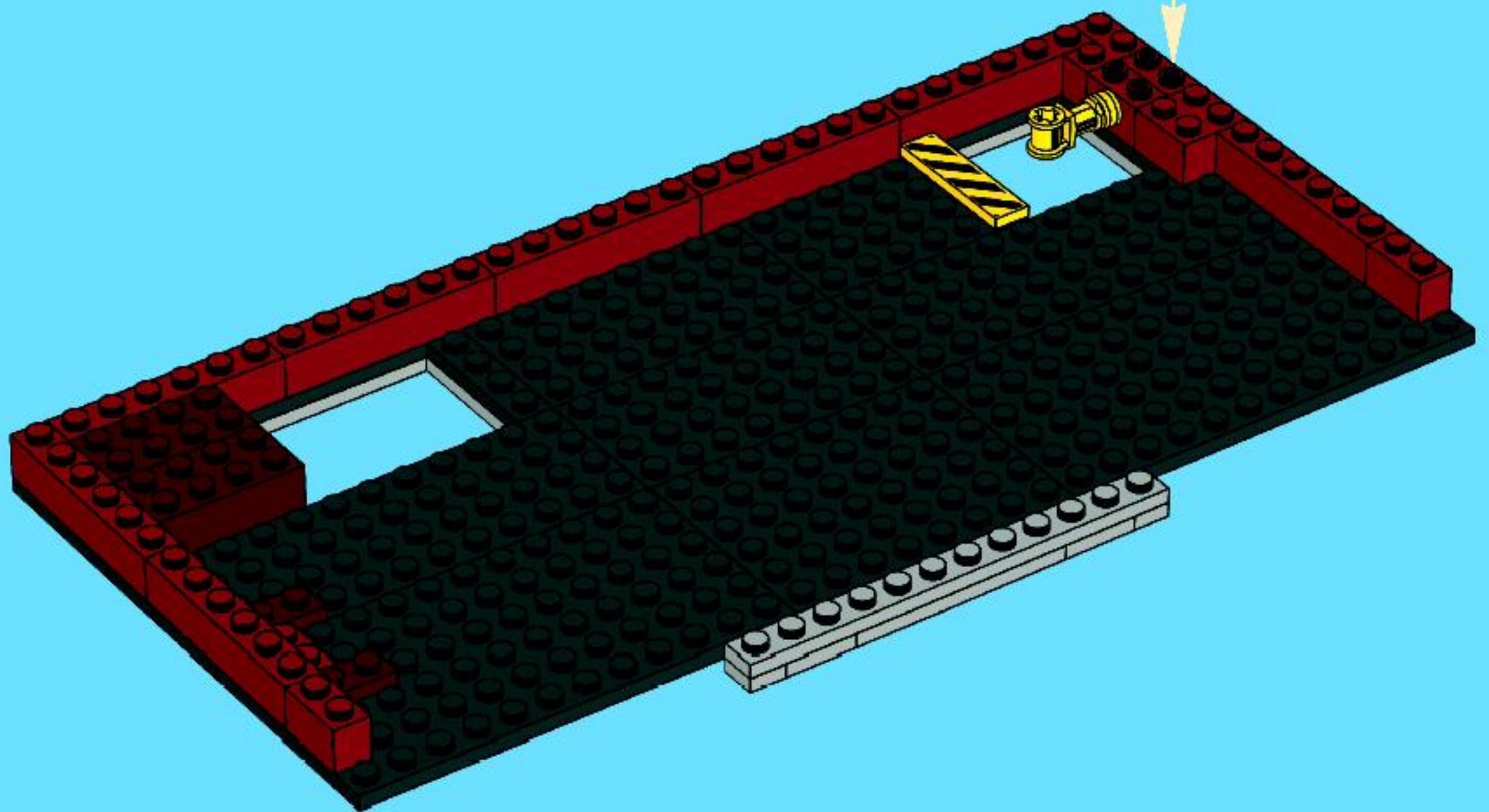
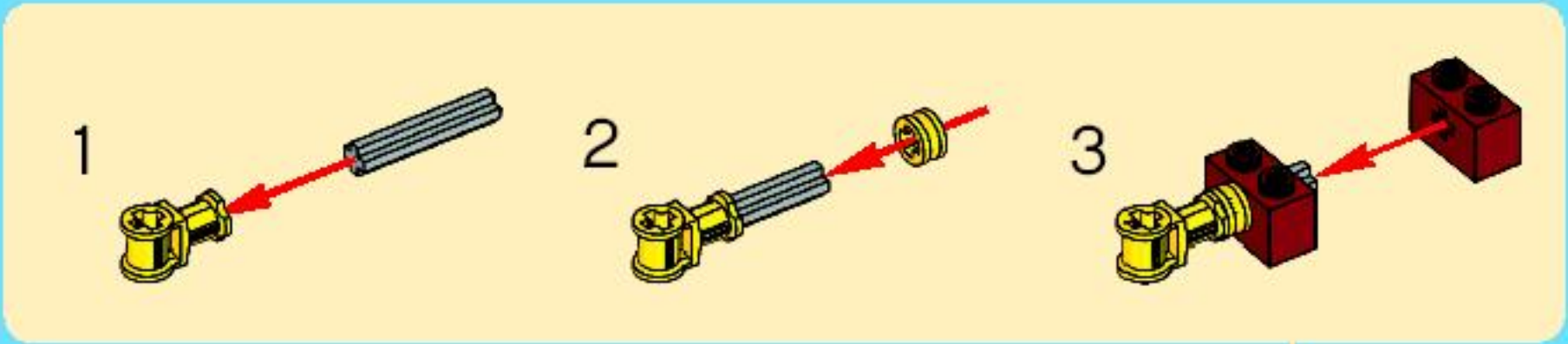

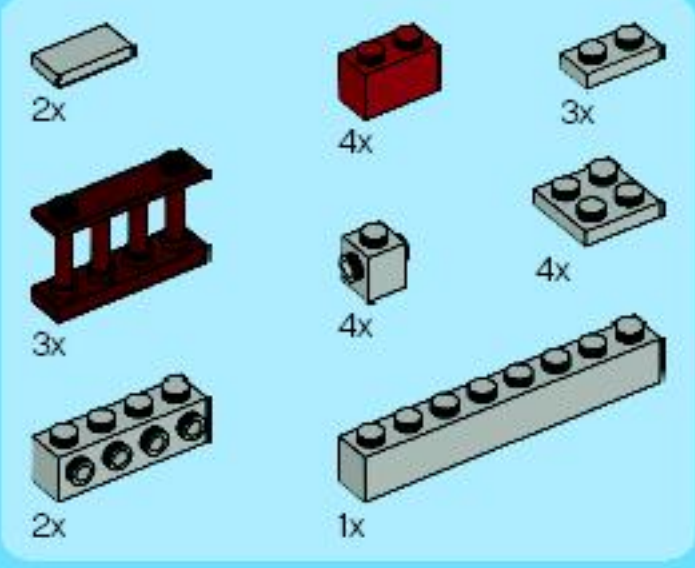

7

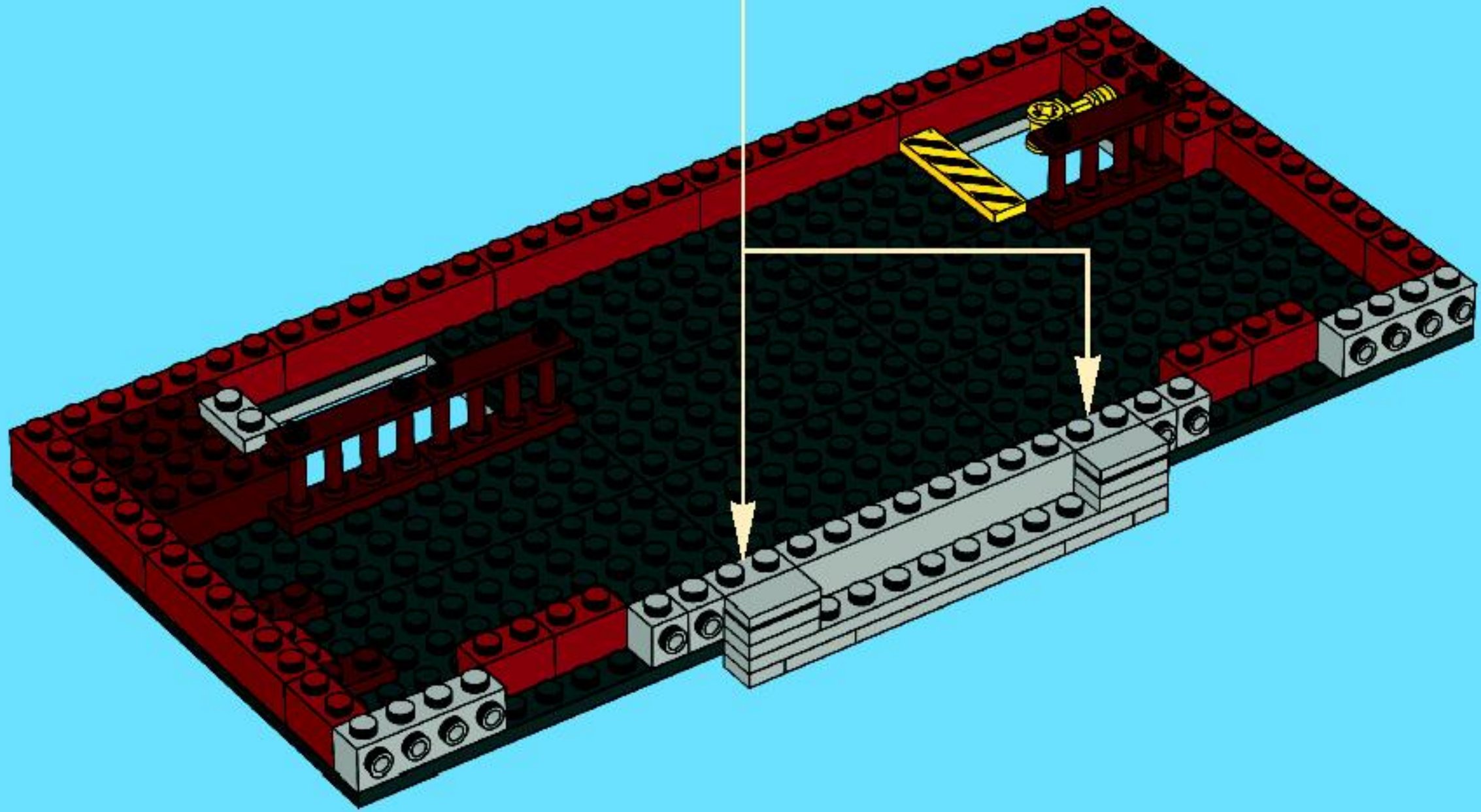
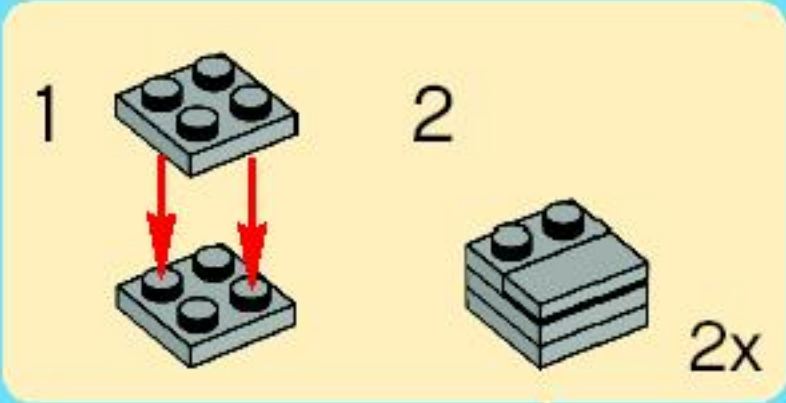

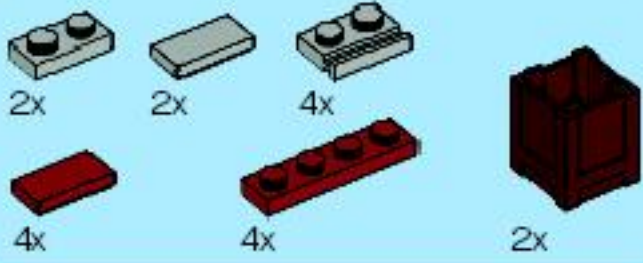

8

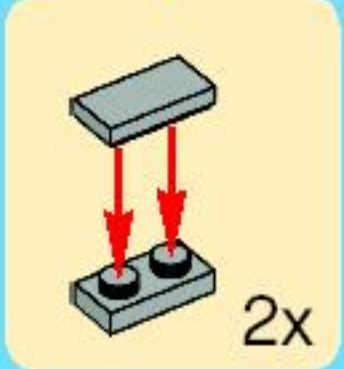
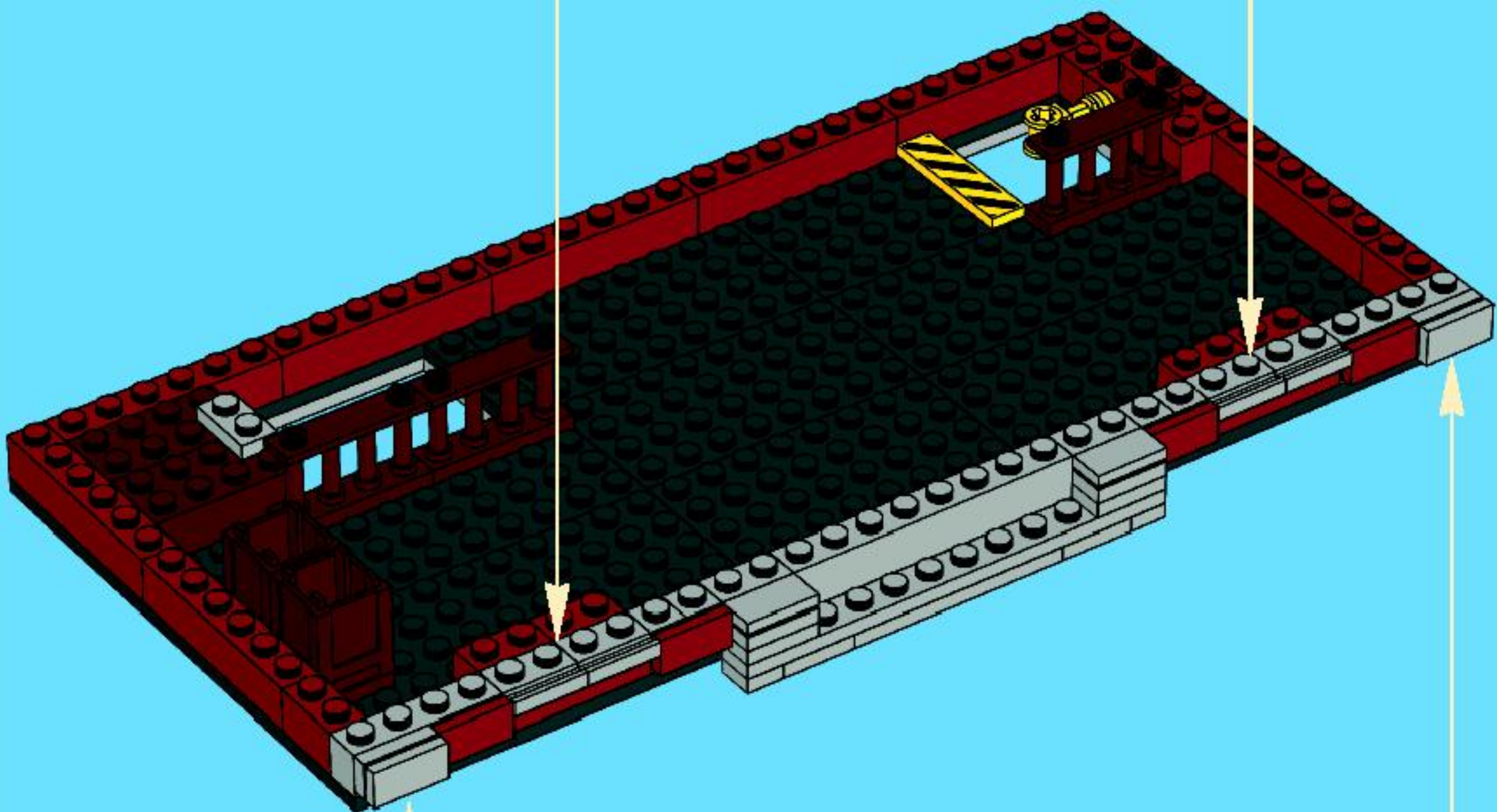
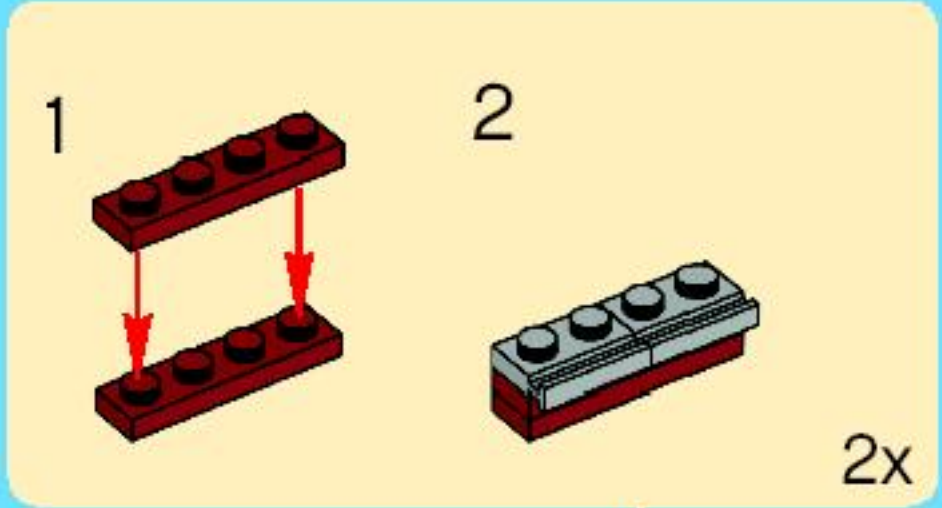

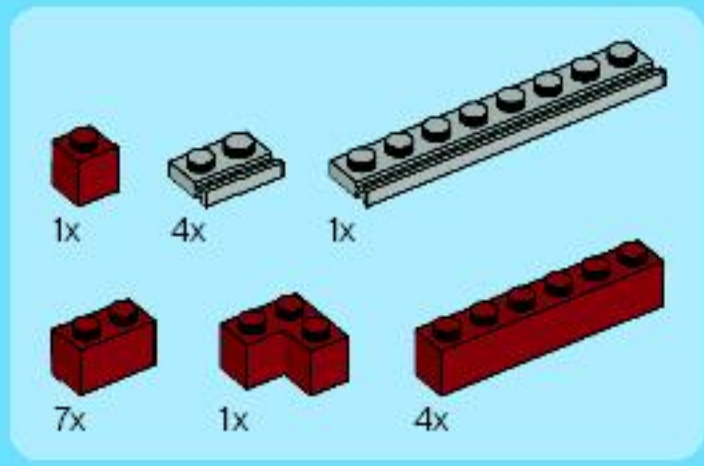

9

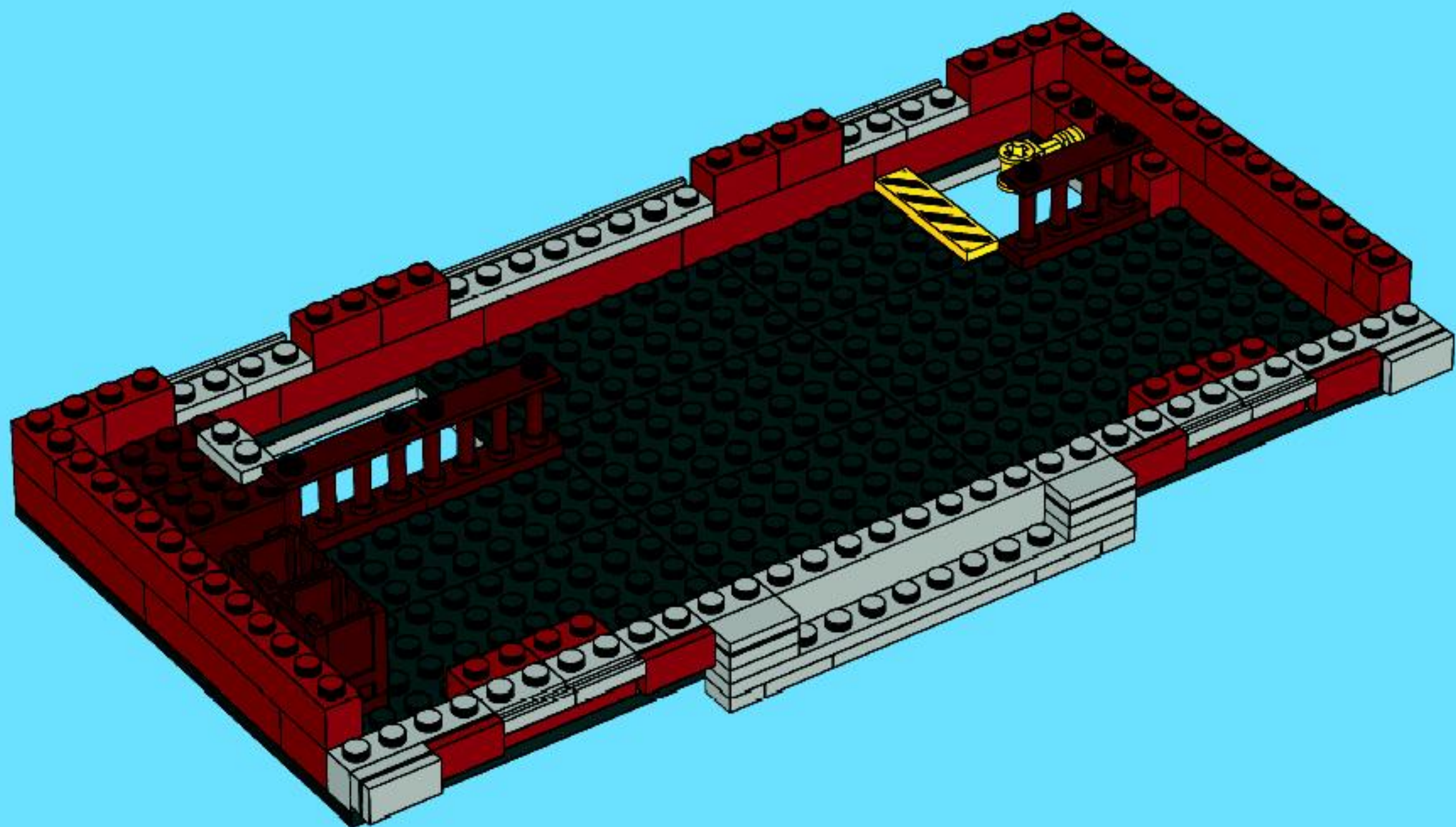

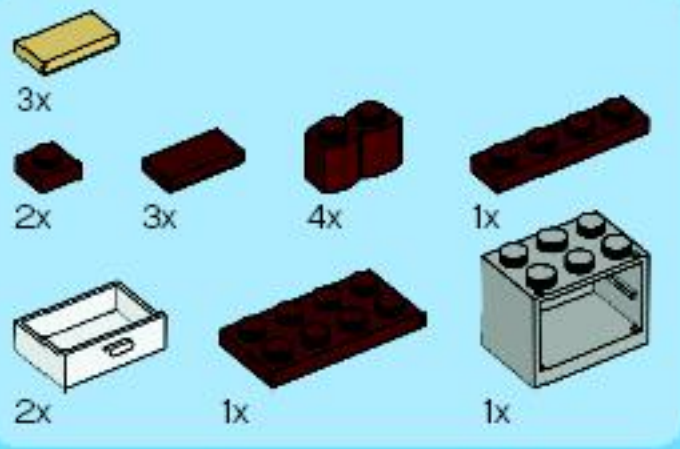

10

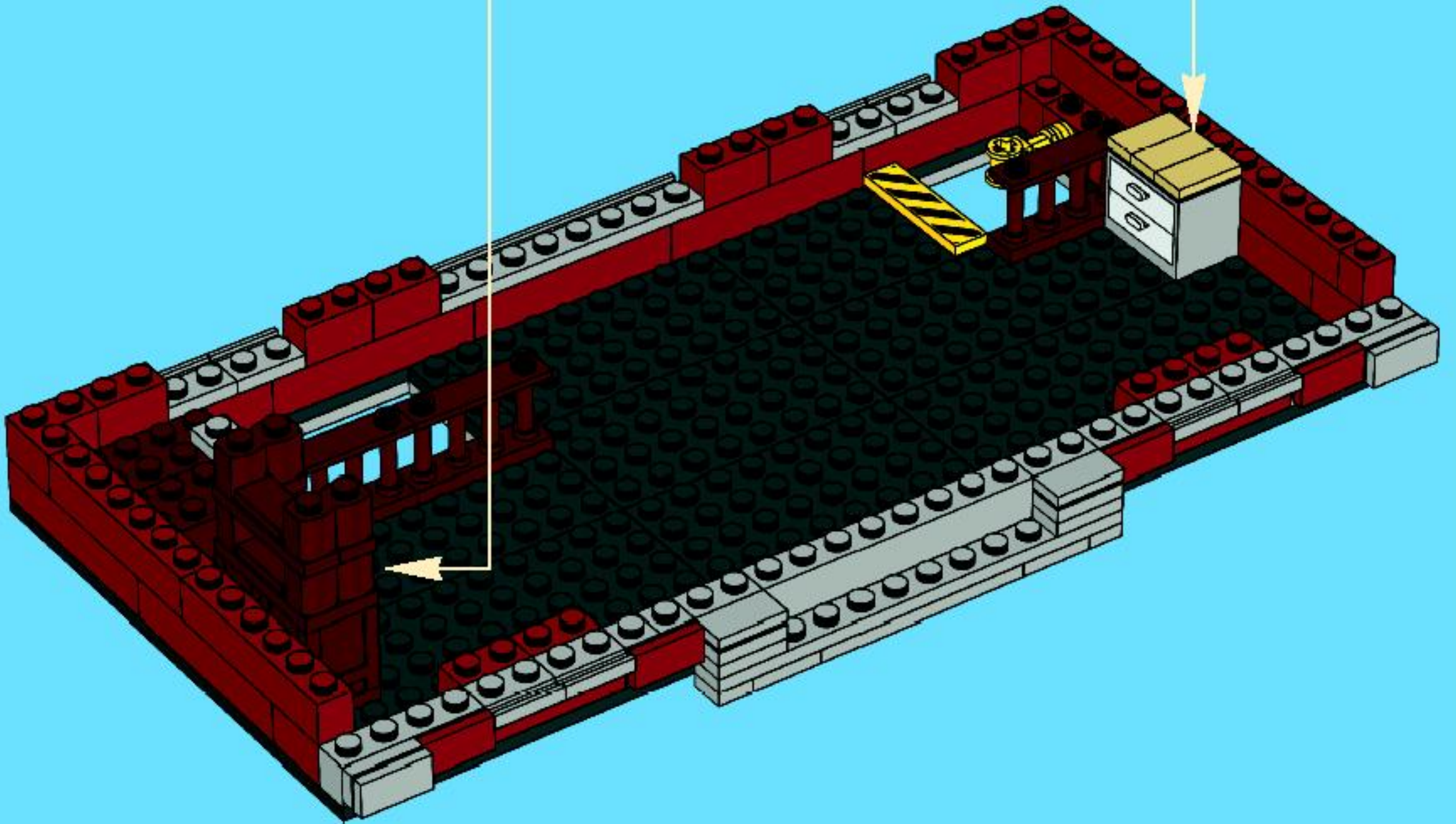
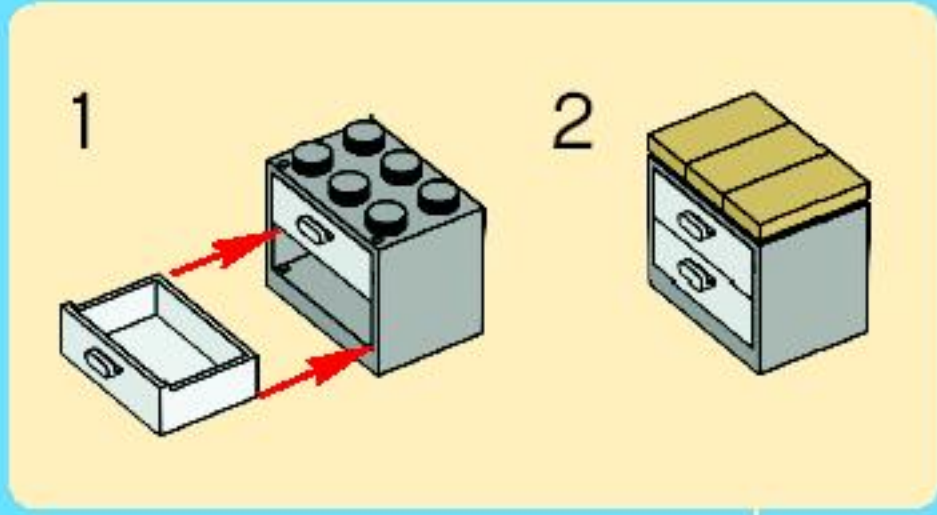
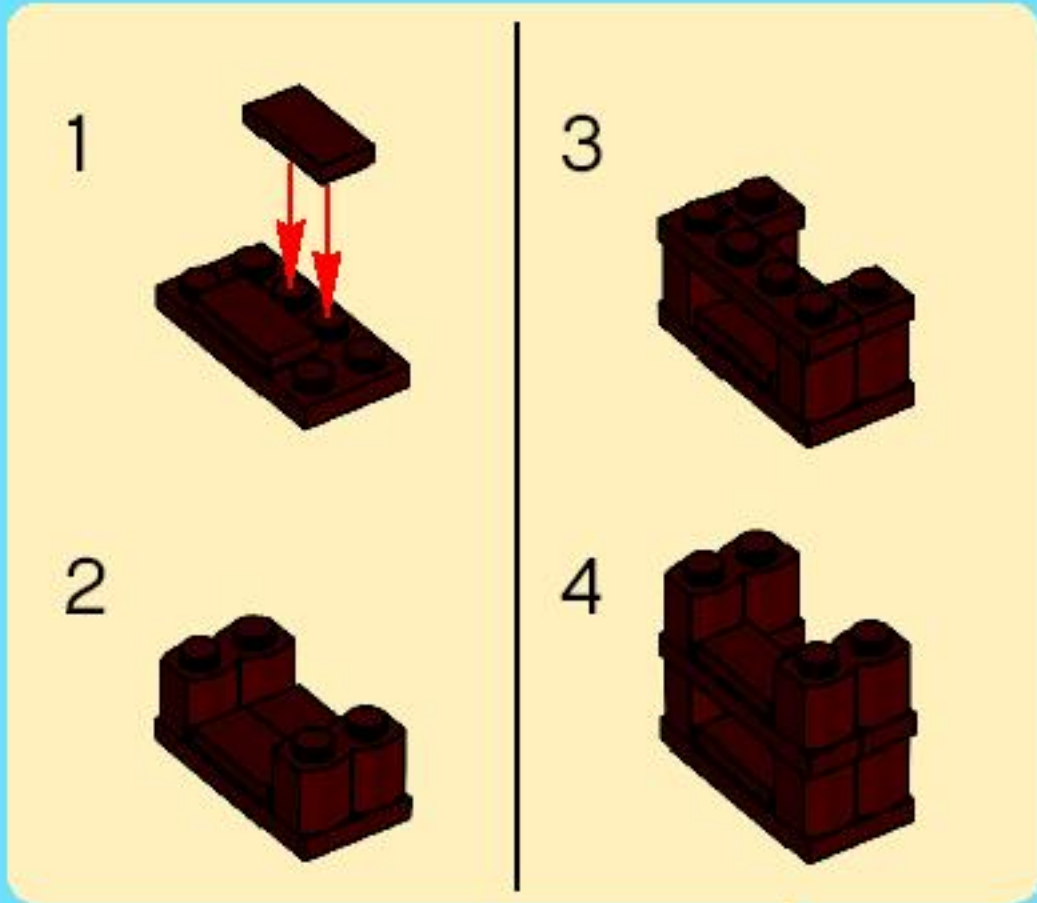

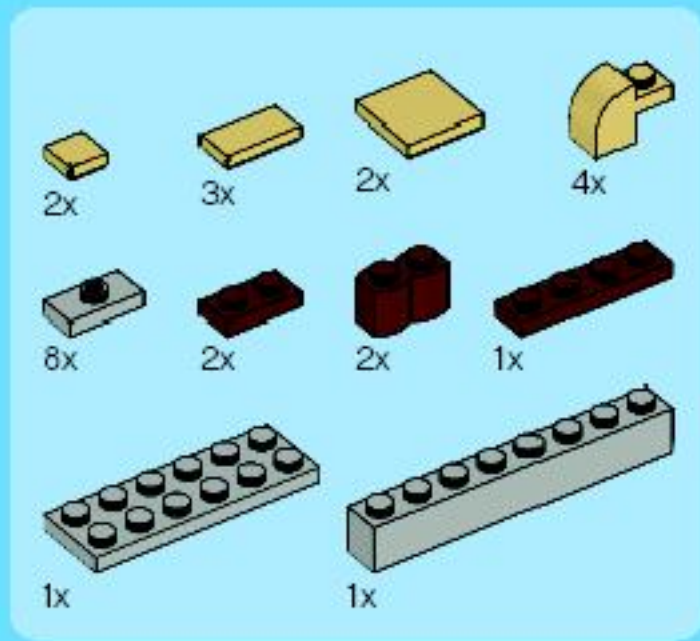

11

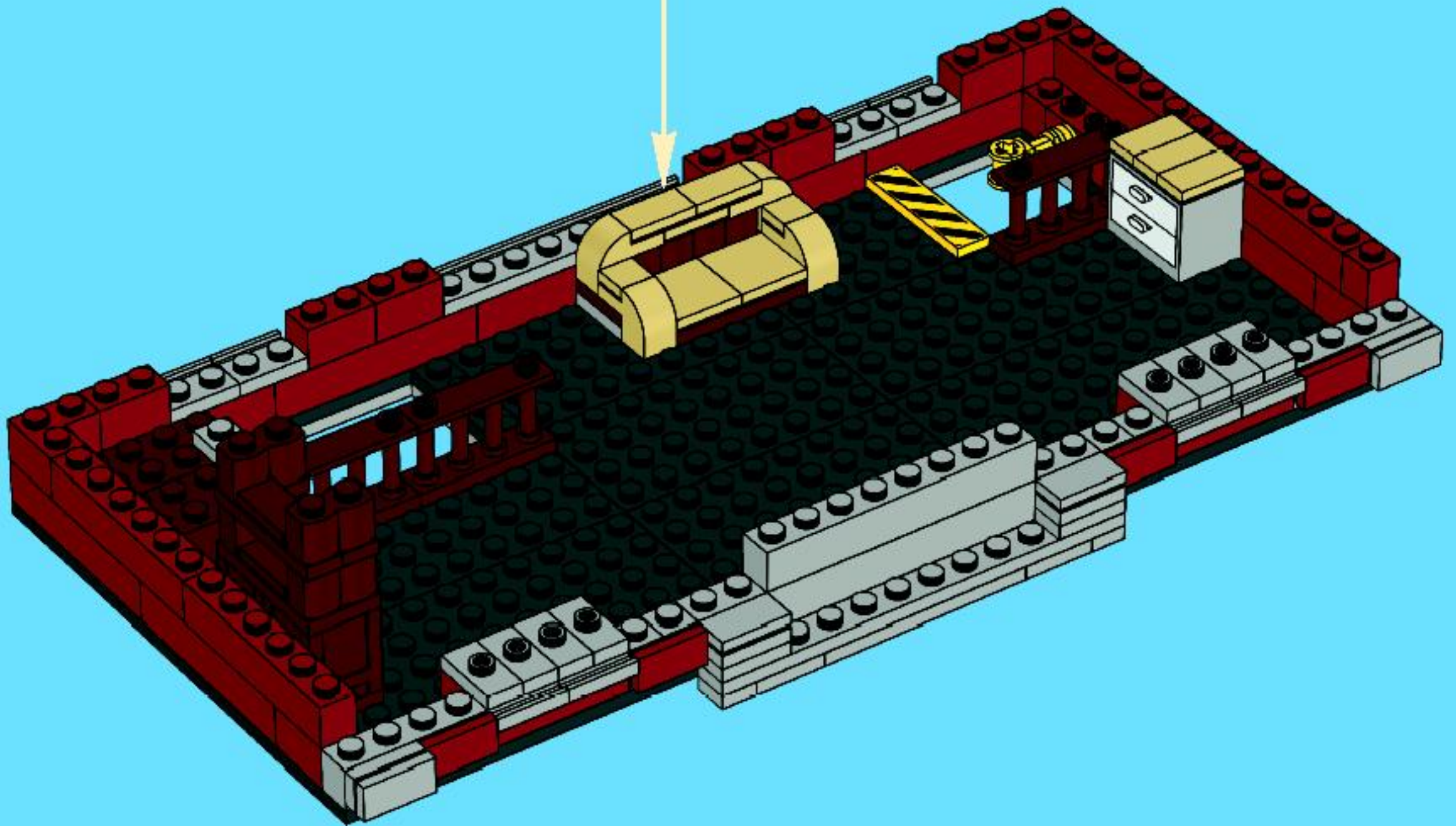
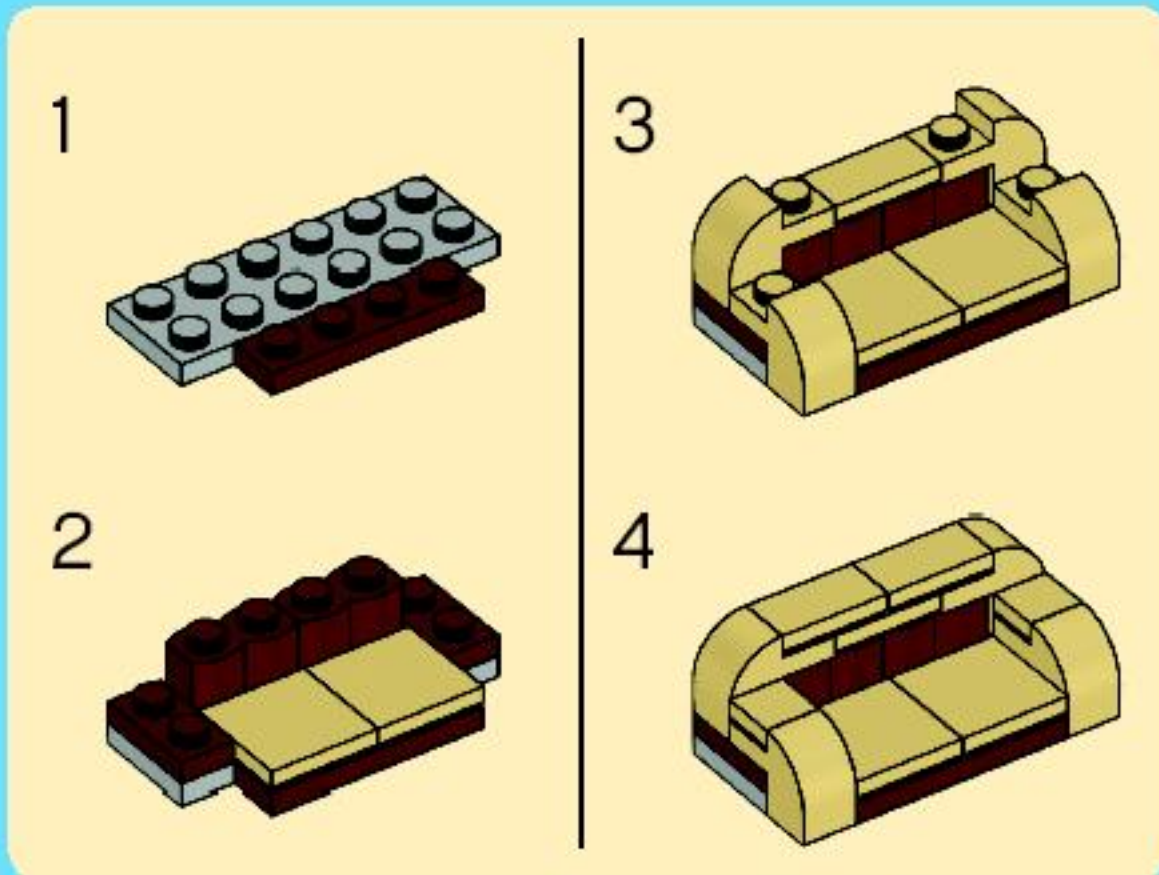

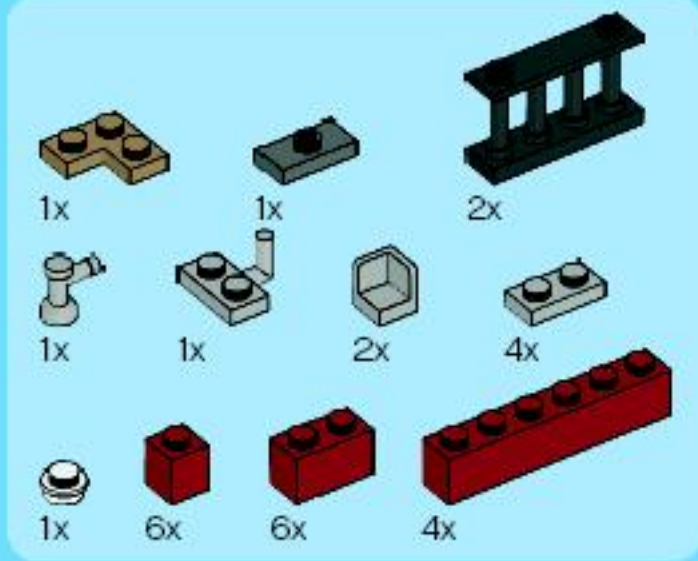

12

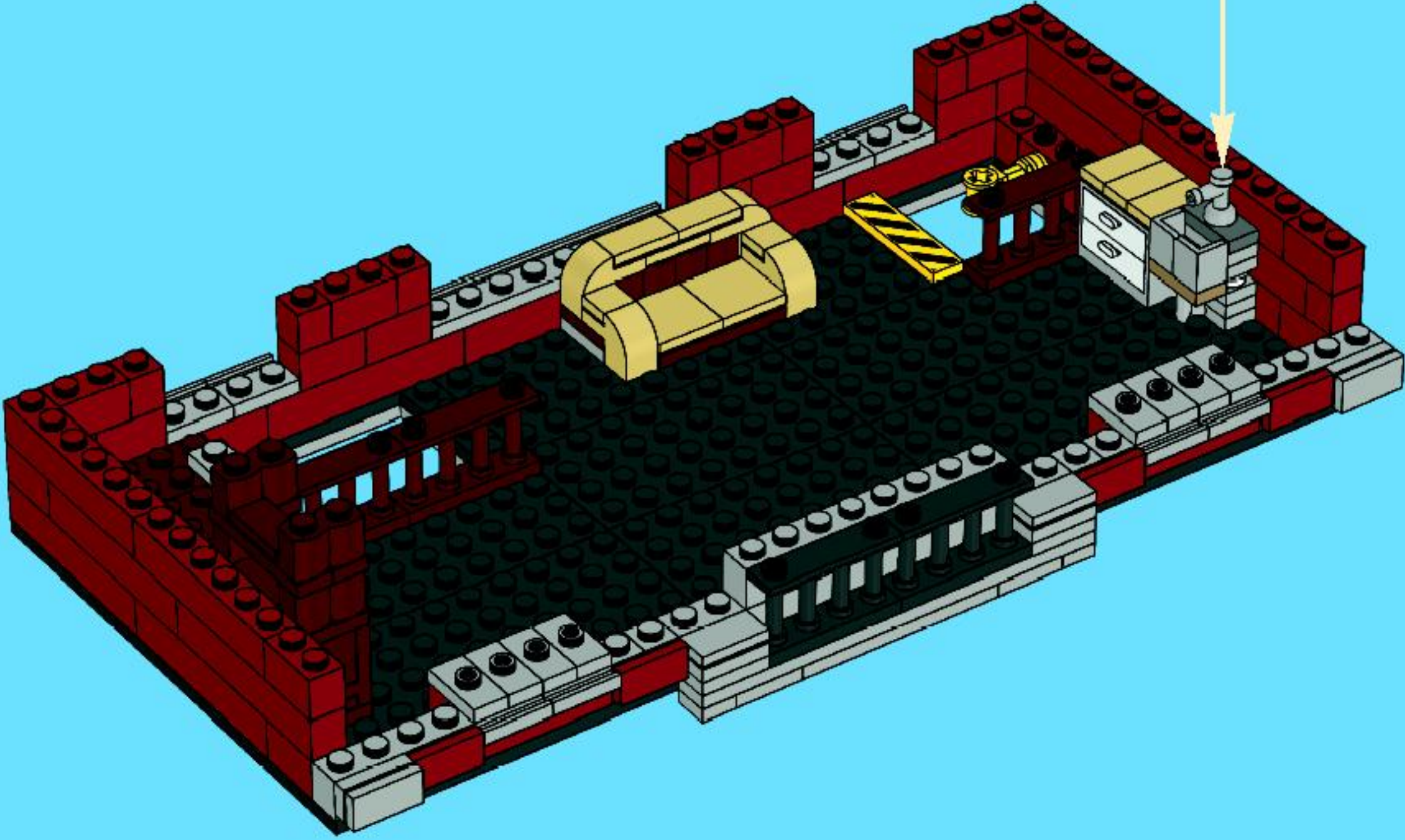
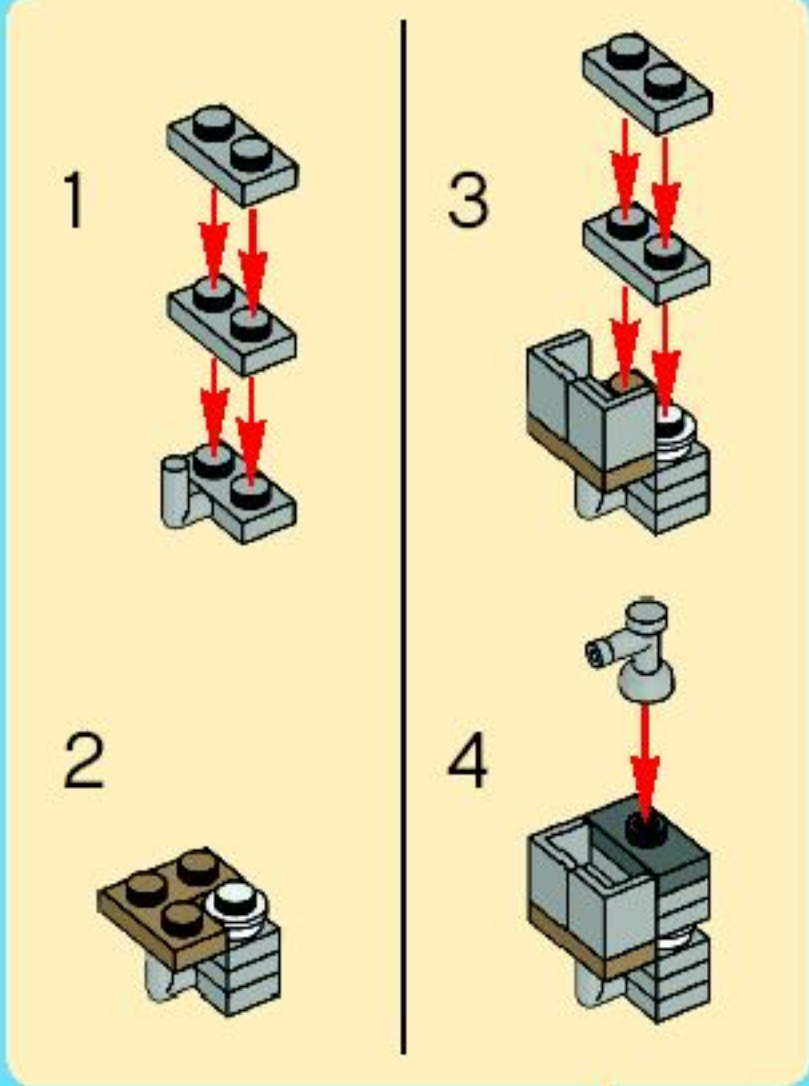

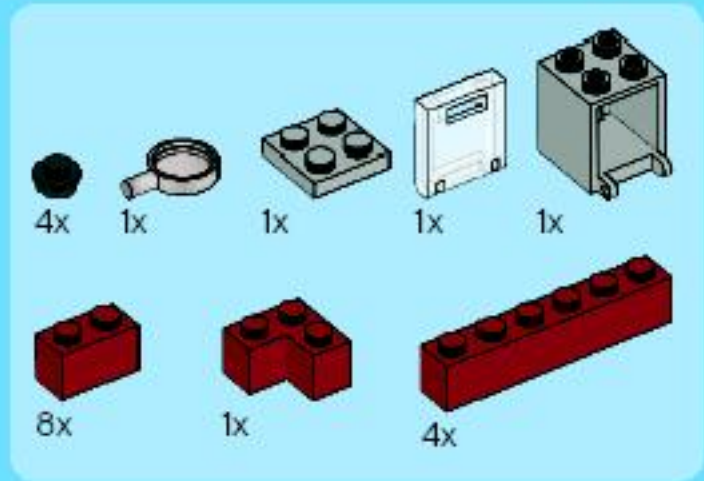

13

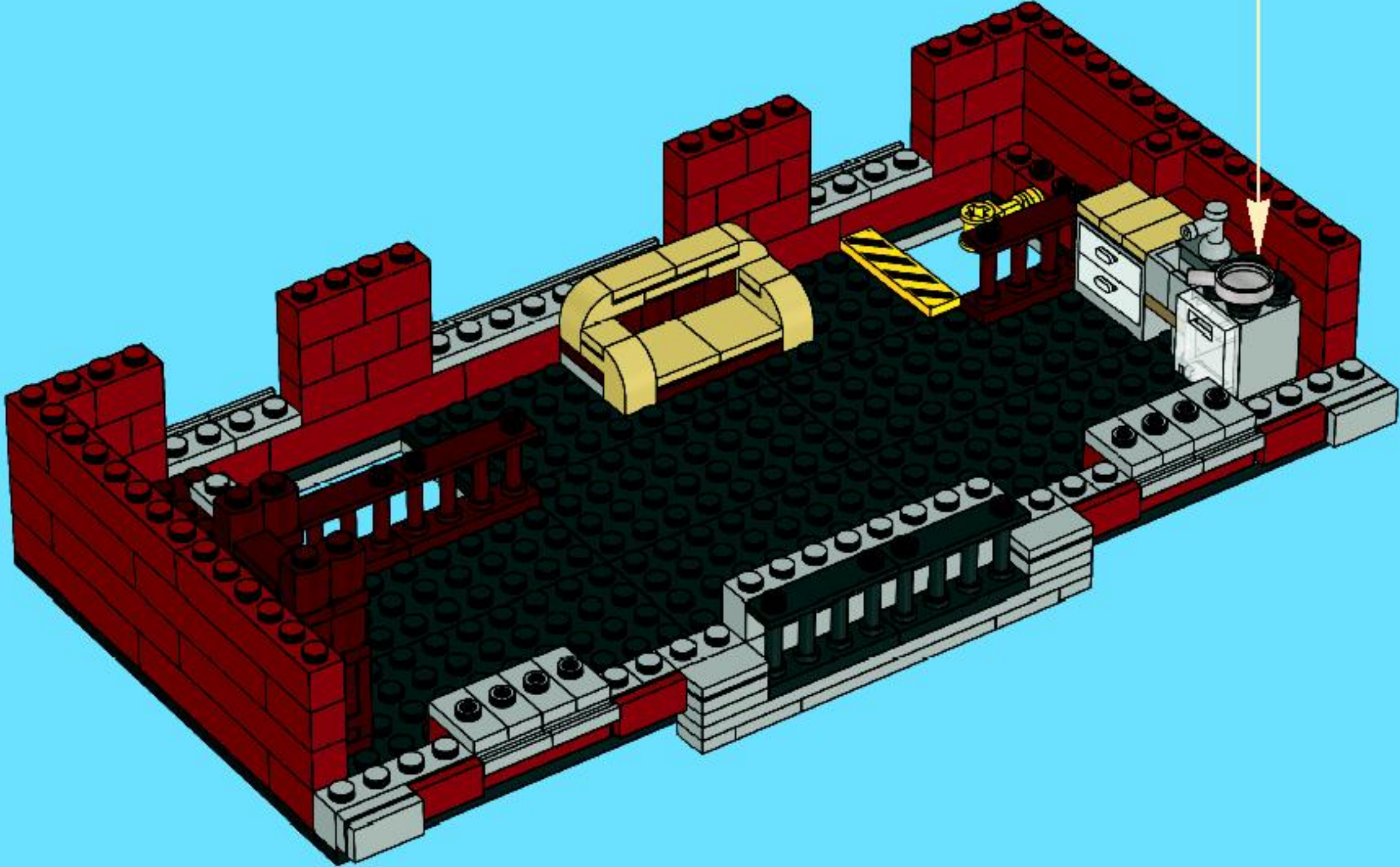
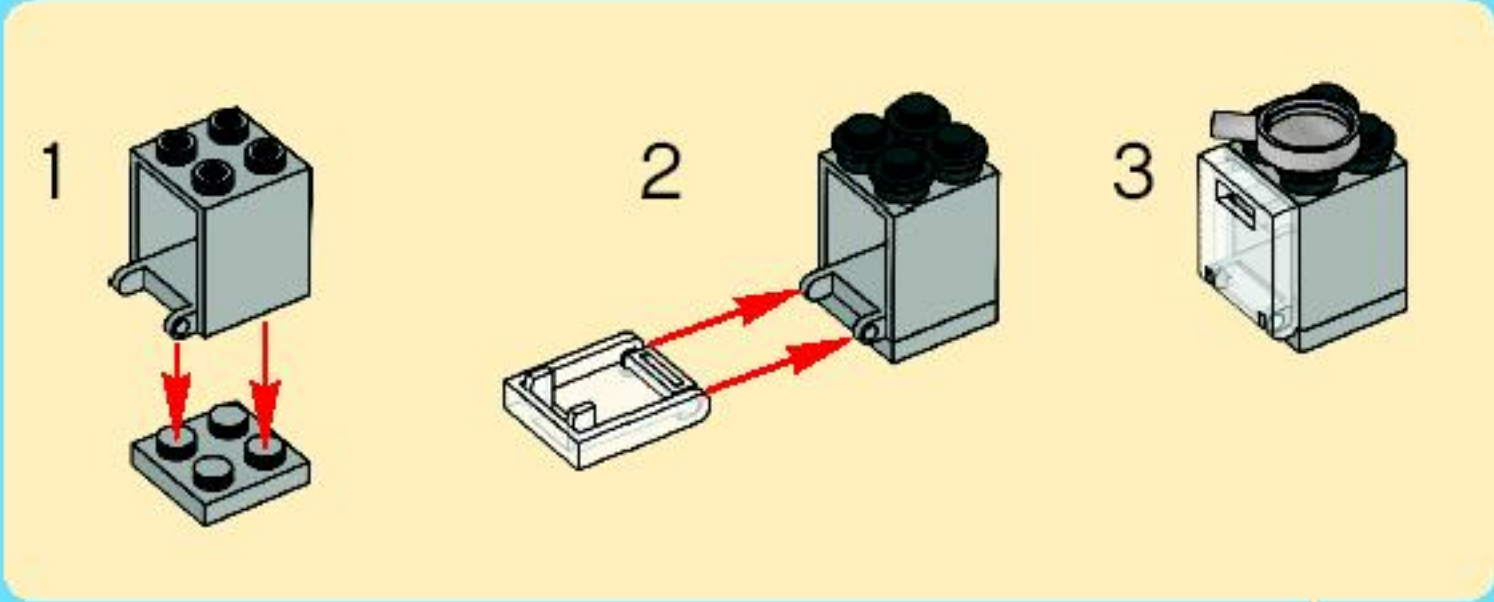

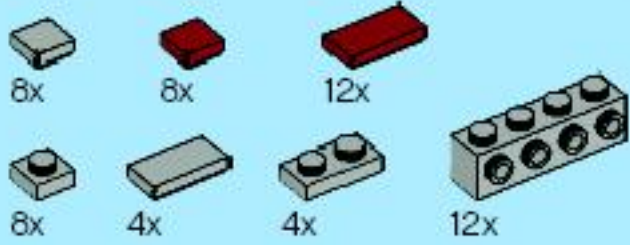

14

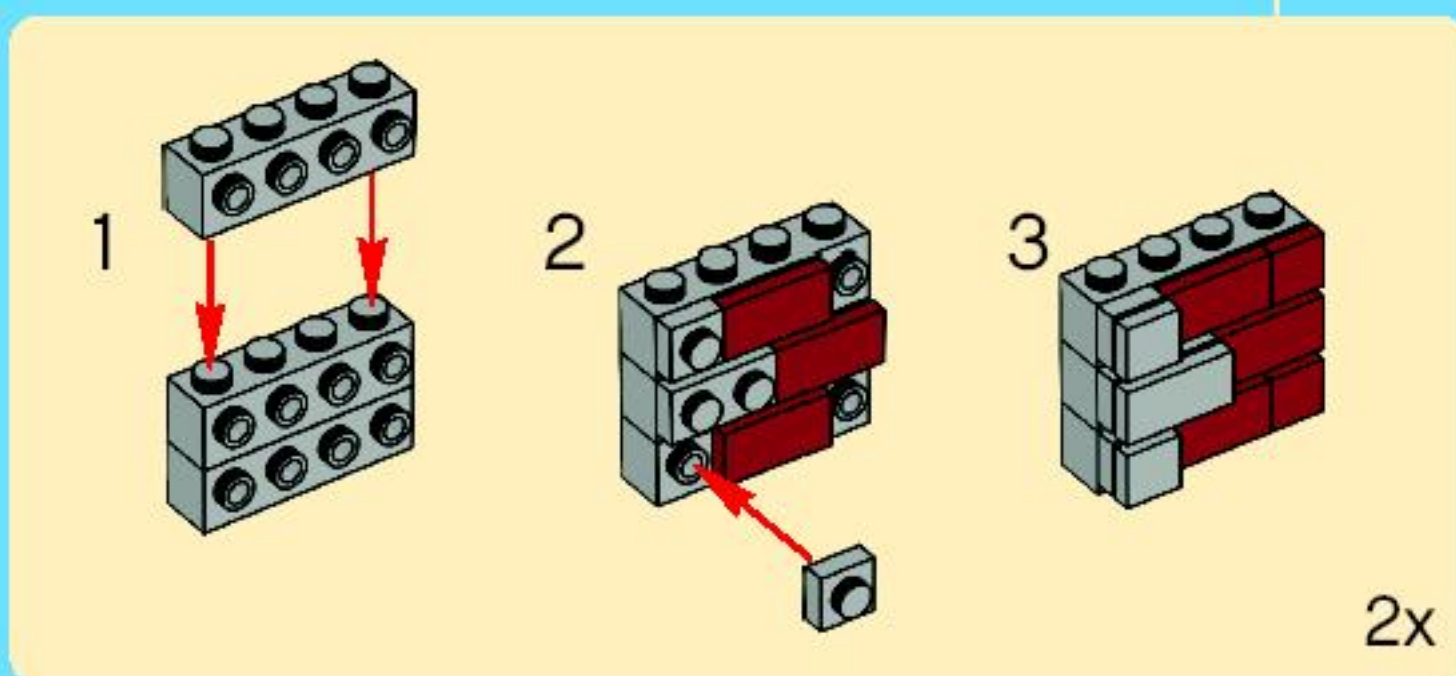
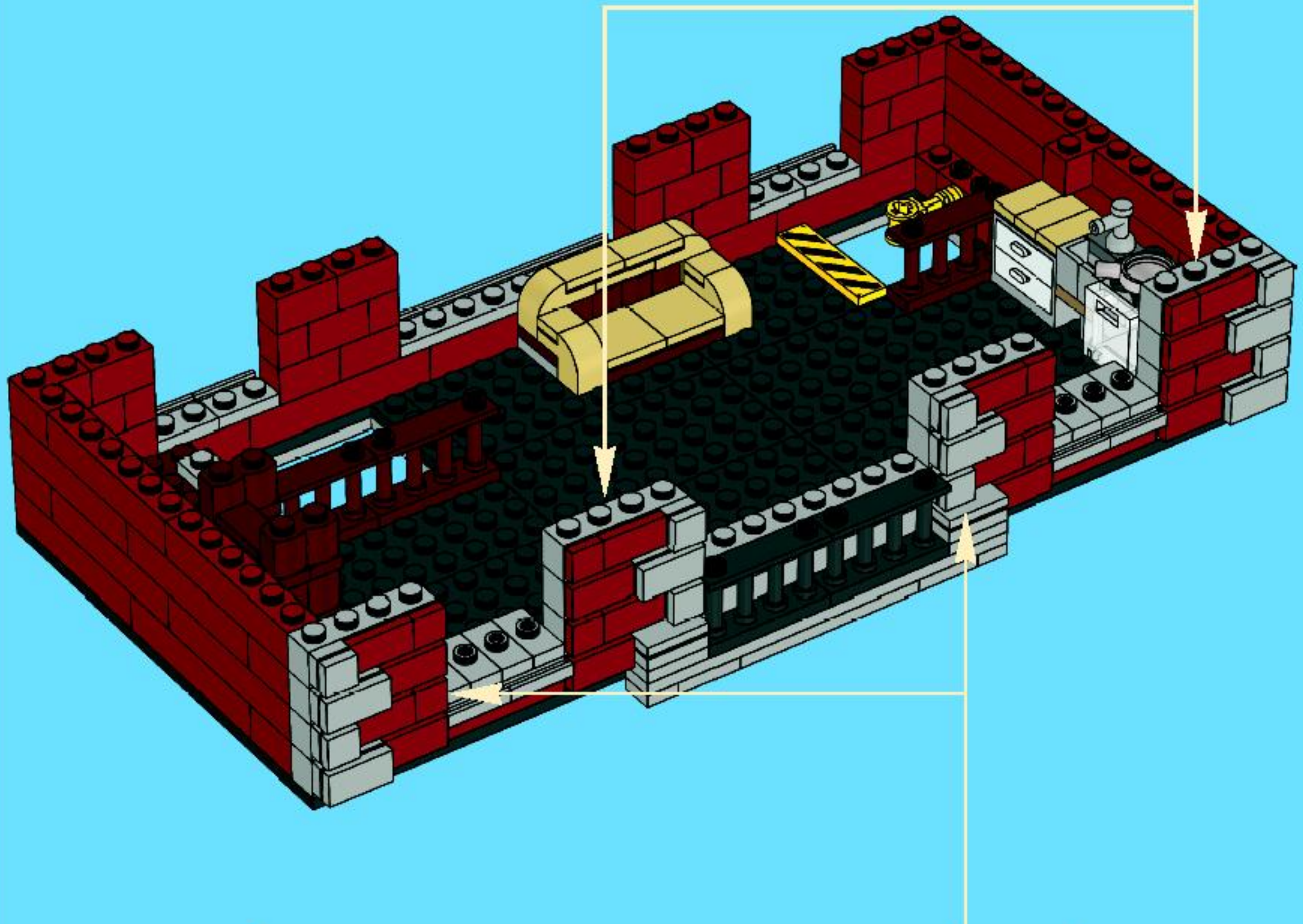
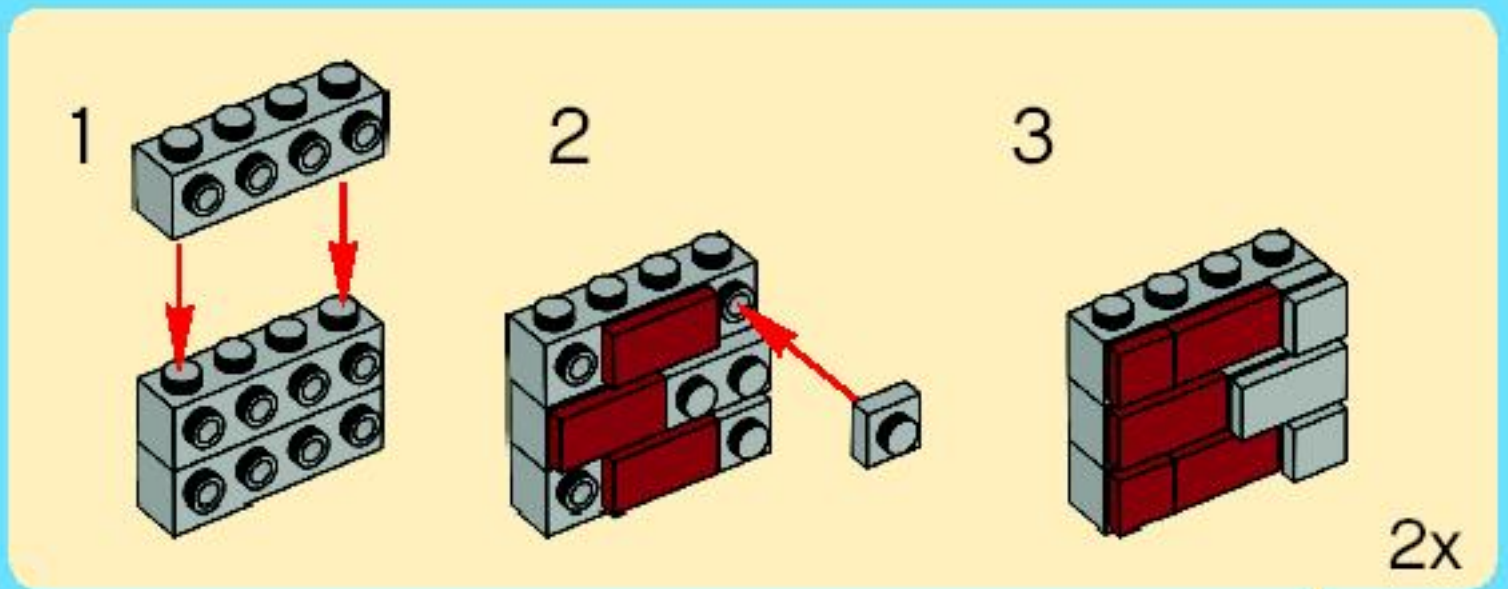



3x

1

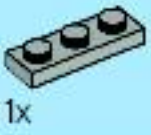
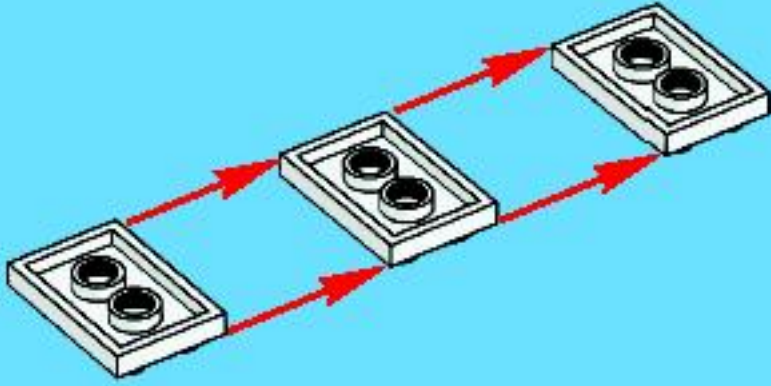

1x

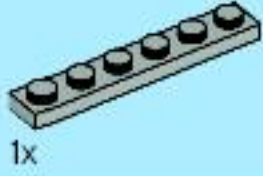

1x

2

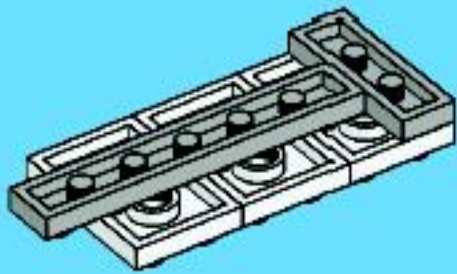

6x

3

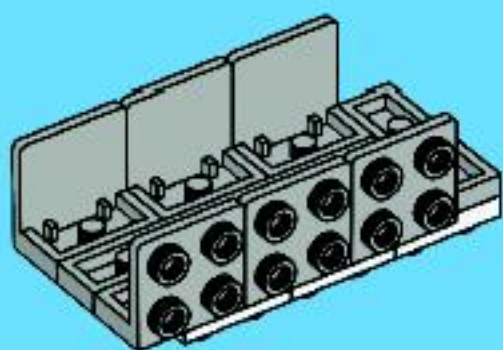

2x

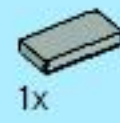

1x



1x

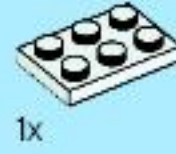

1x

4

1

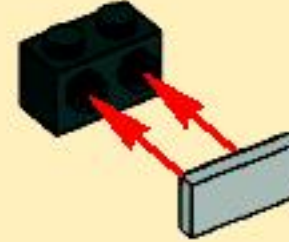

2

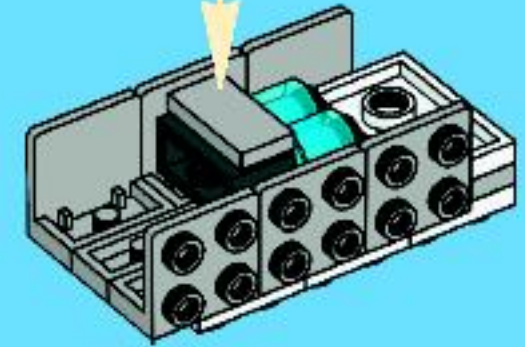

2x

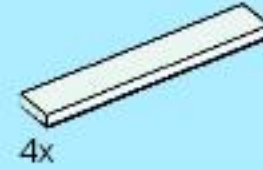

4x

5

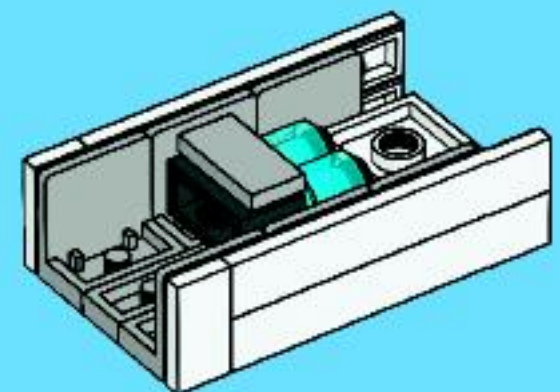

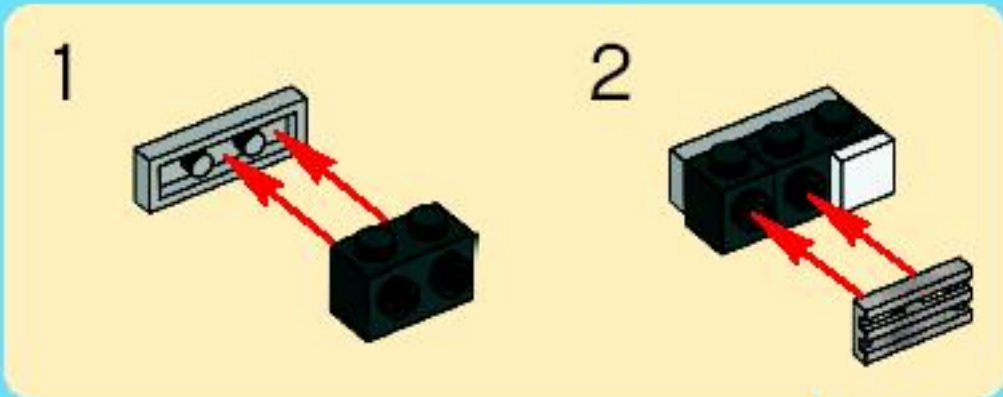
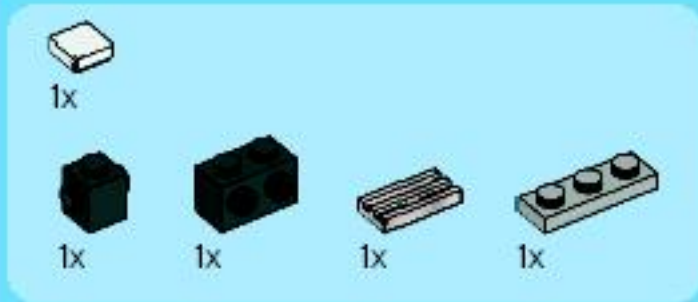

6

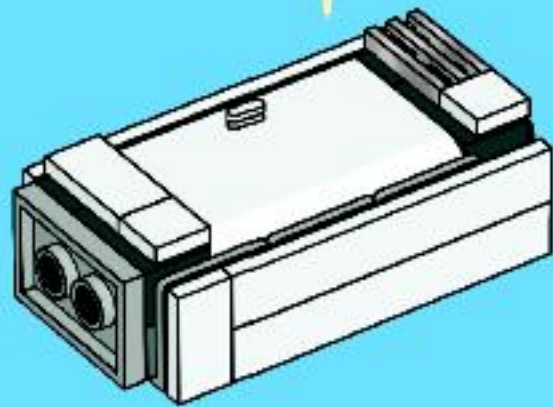
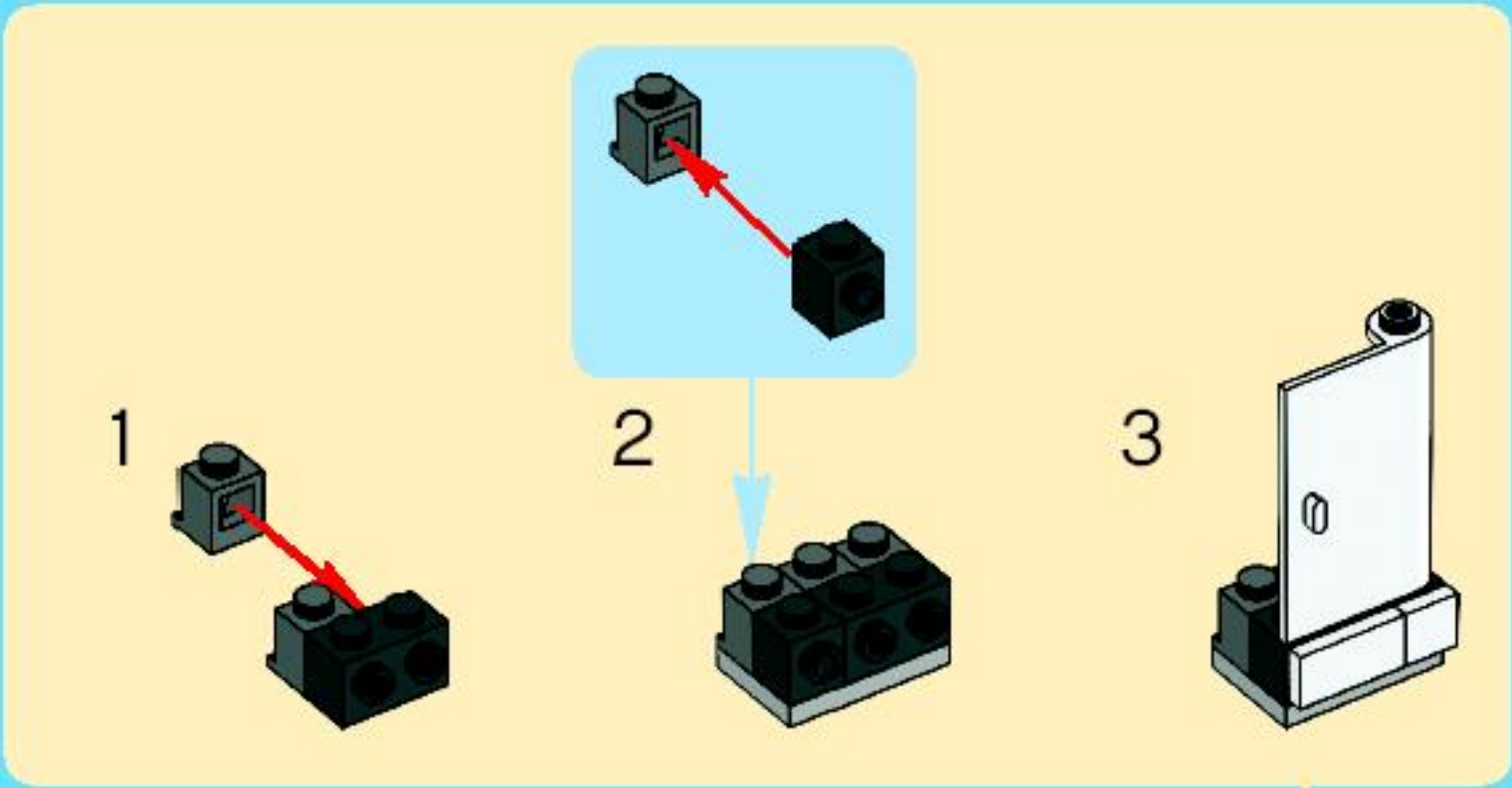
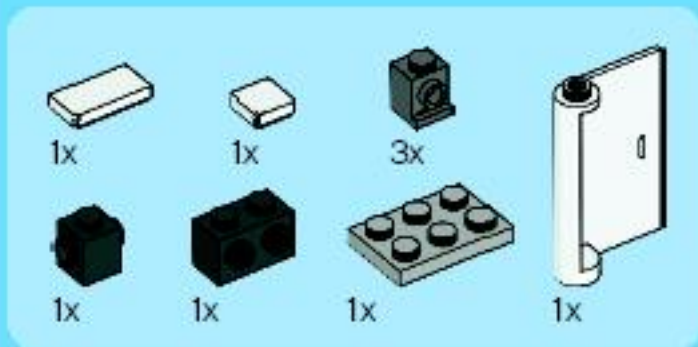
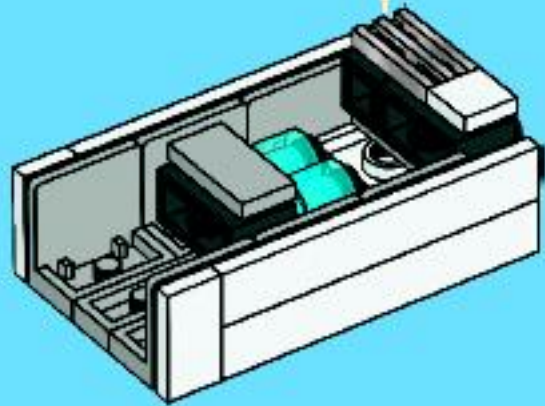

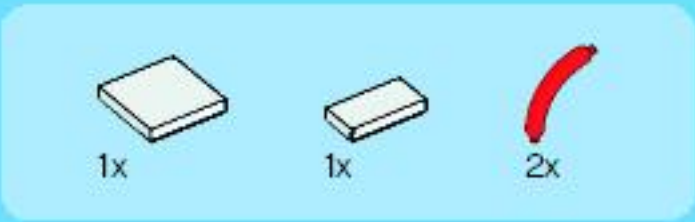

8



15

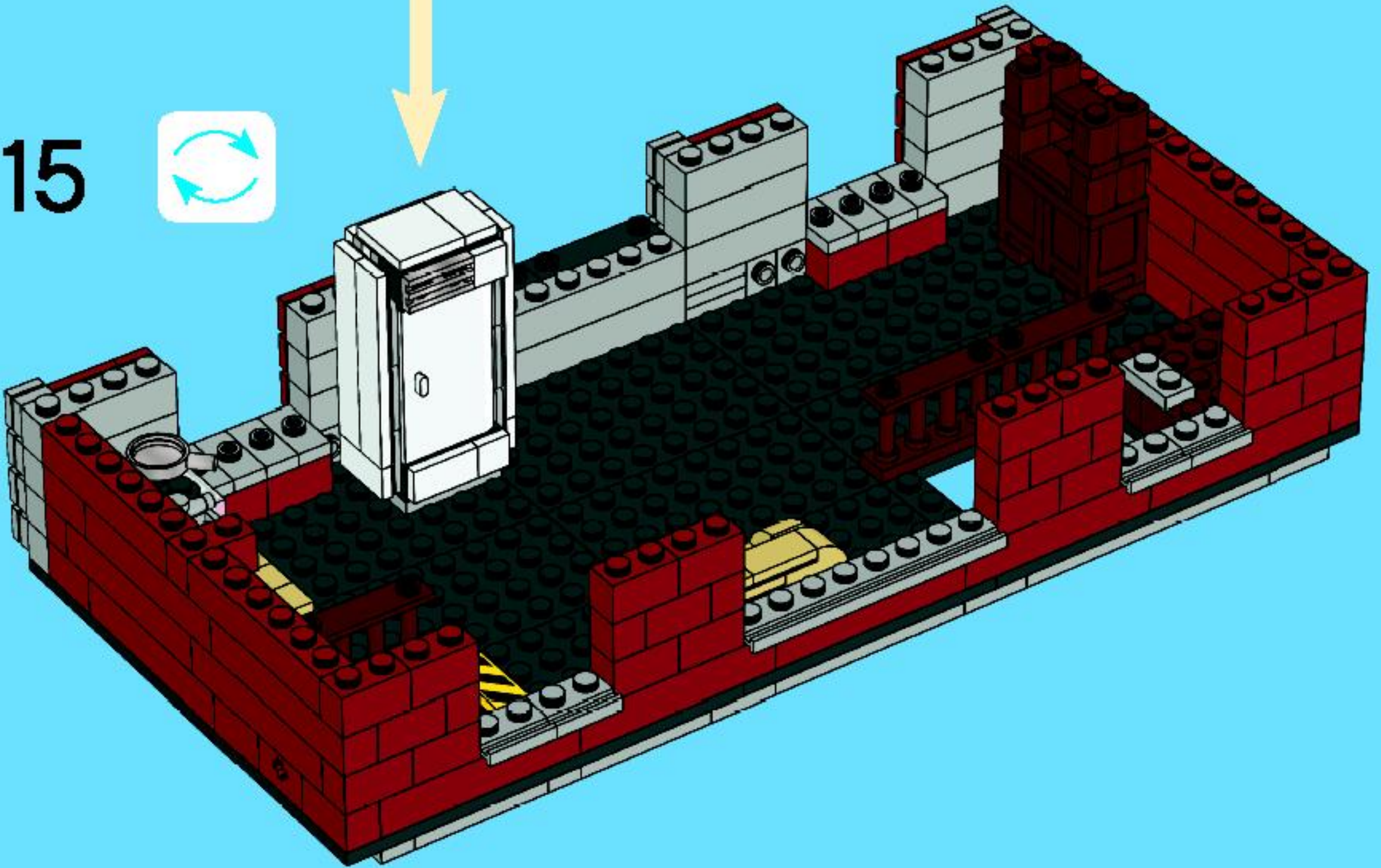

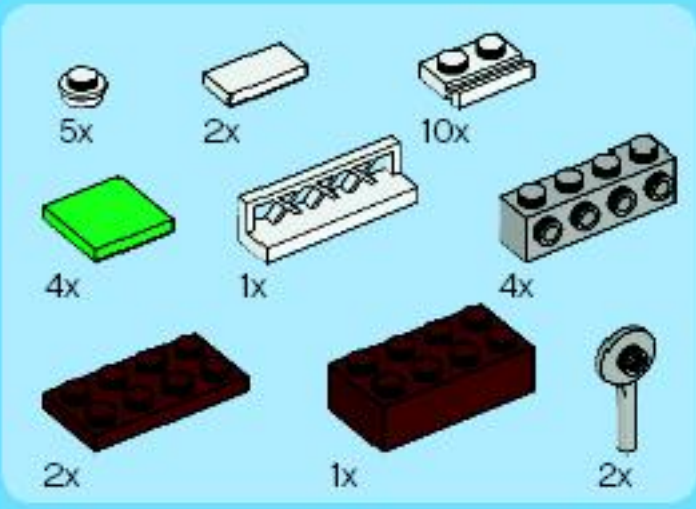

16

1

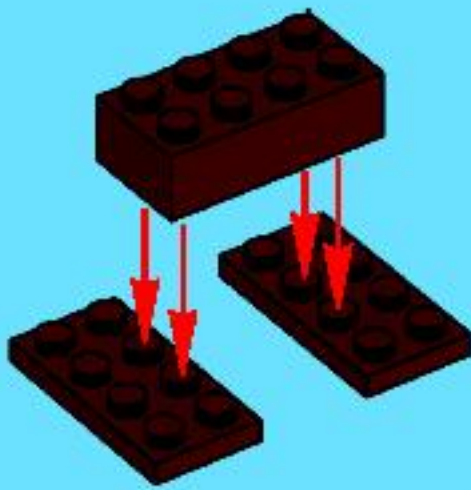

2

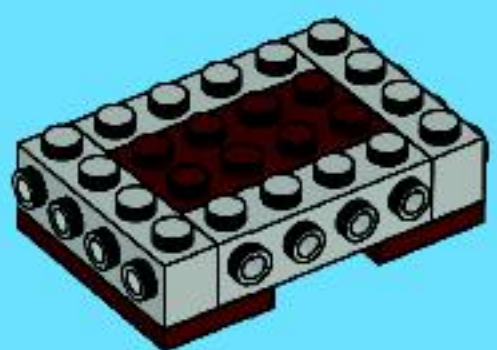

3

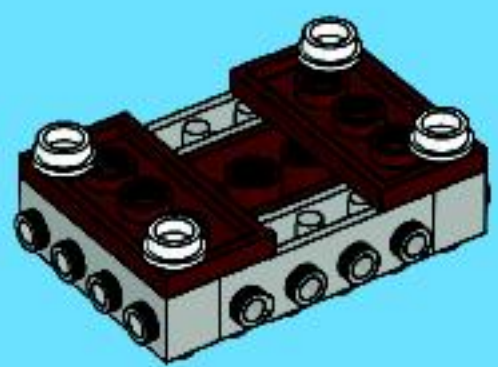

4

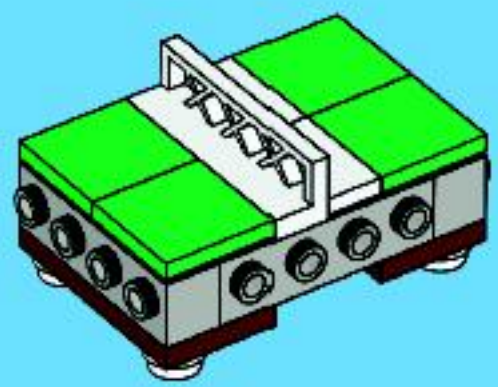

5

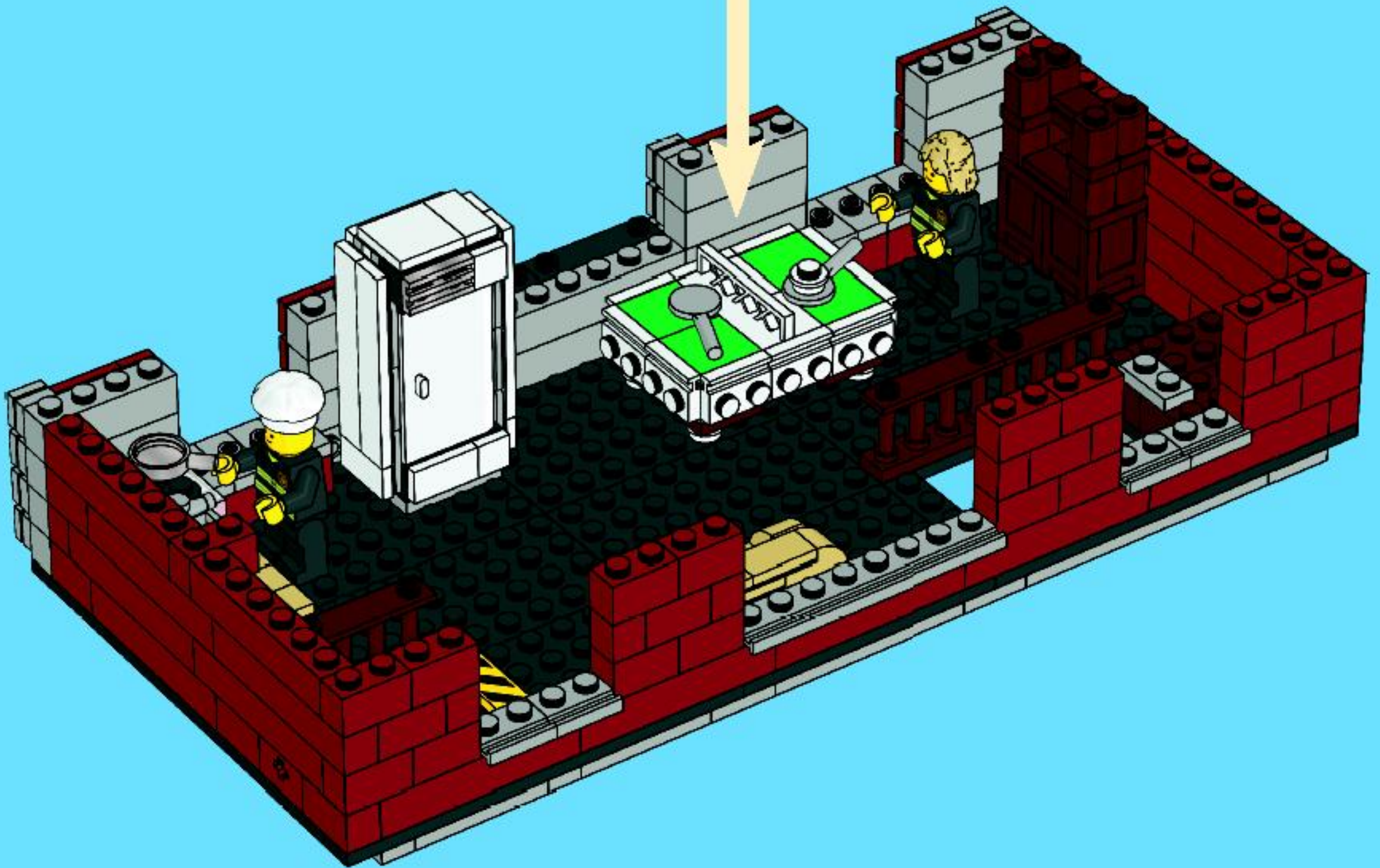
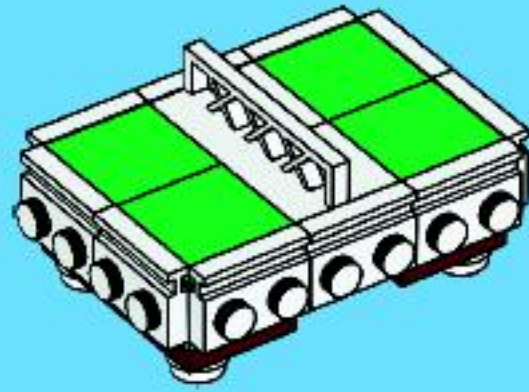

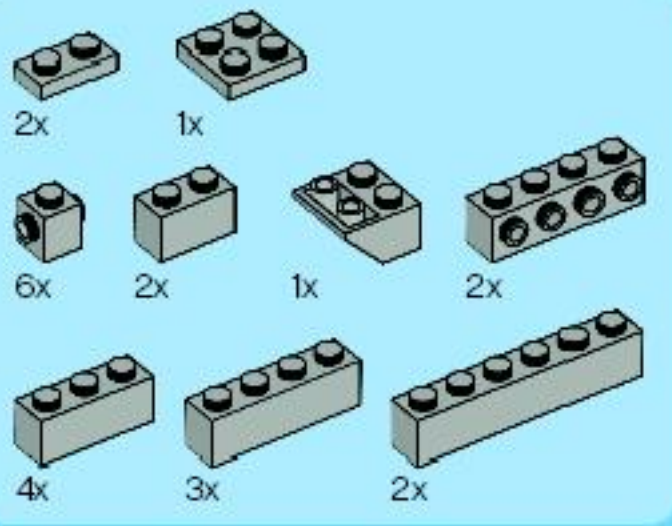

17

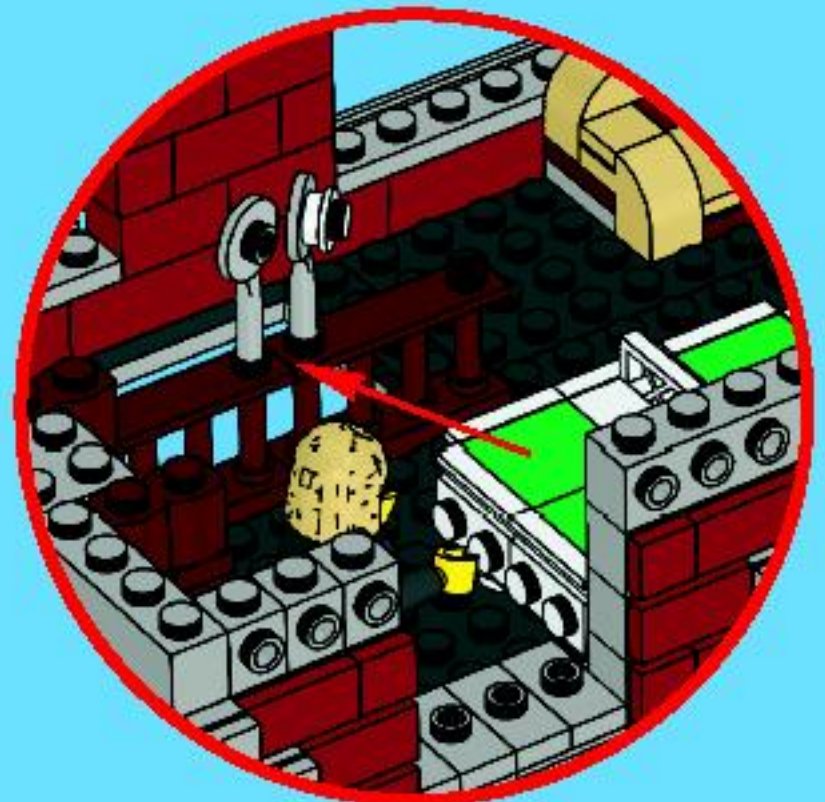
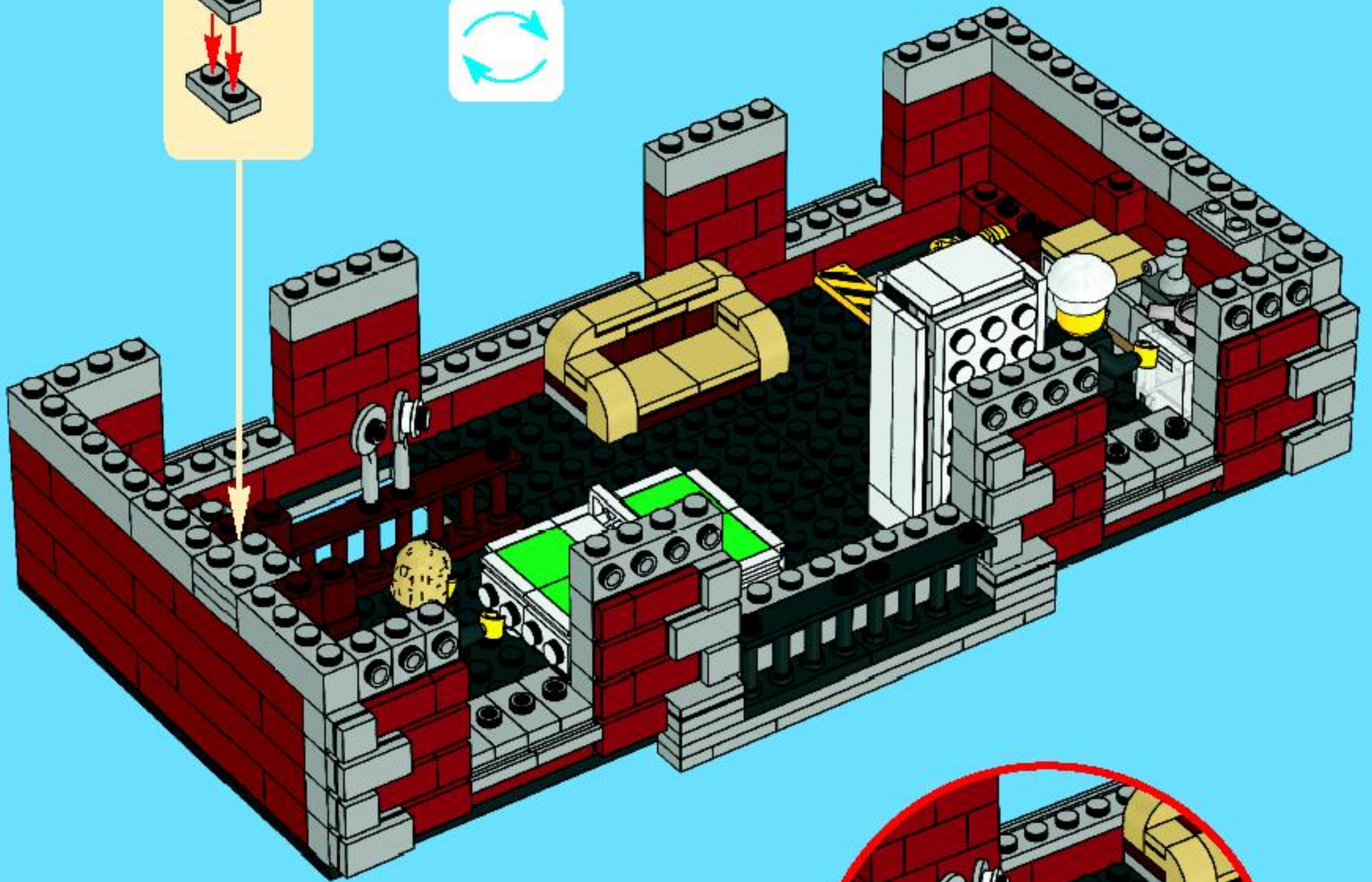
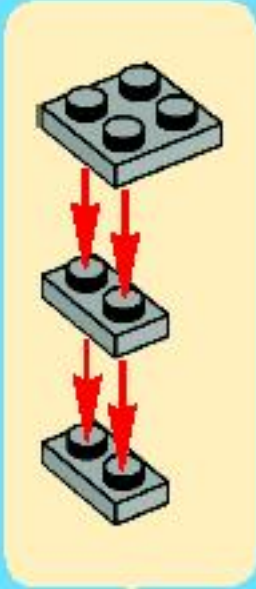

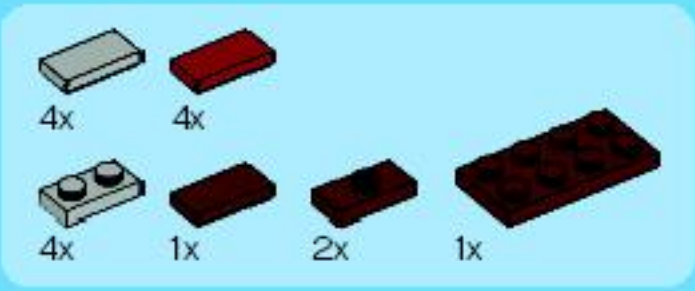

18

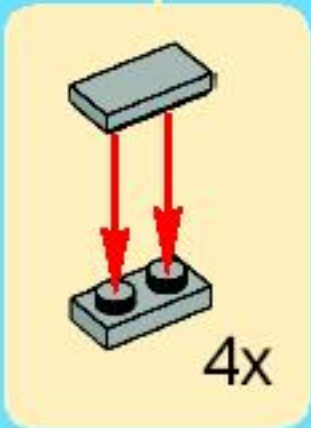
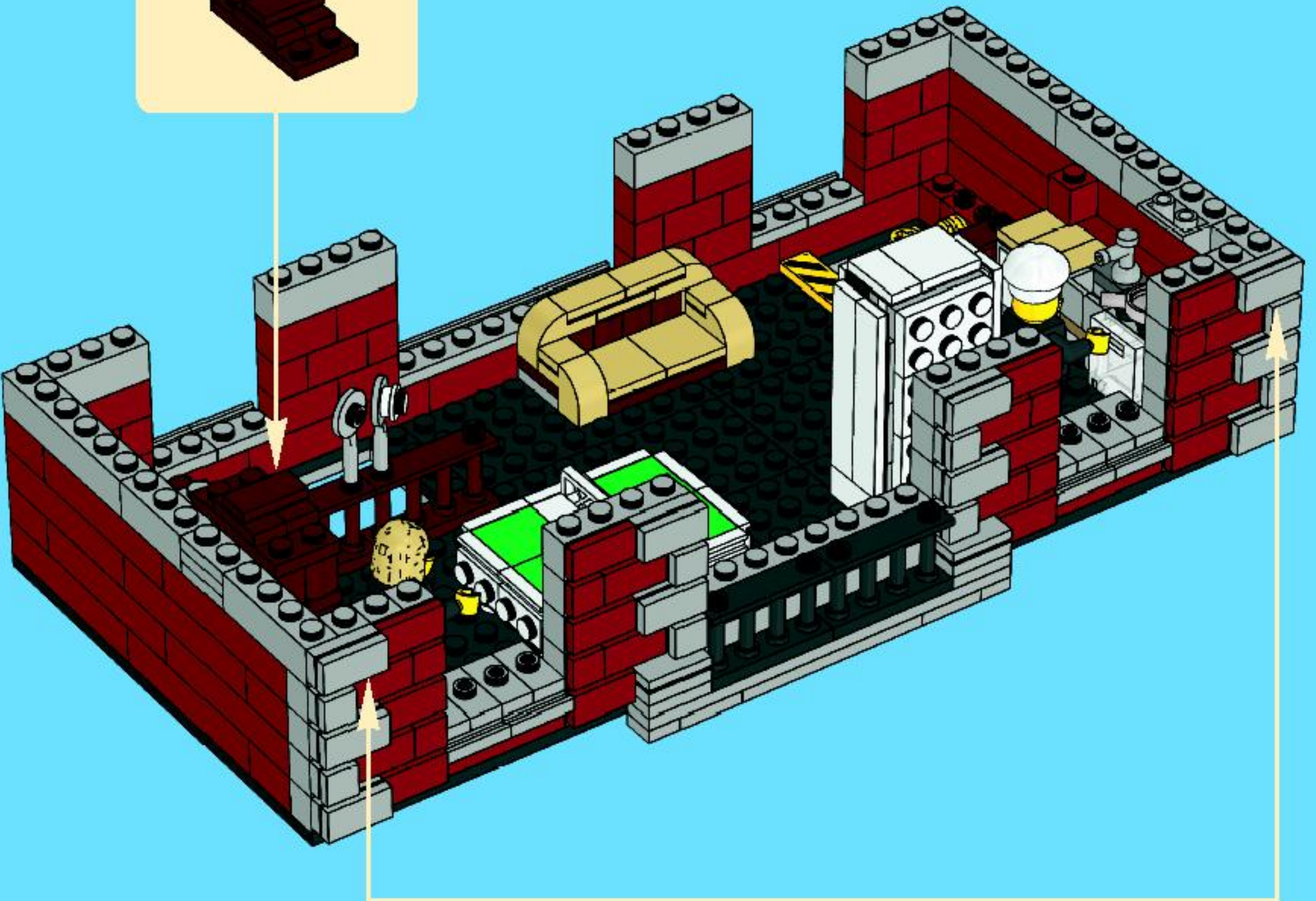
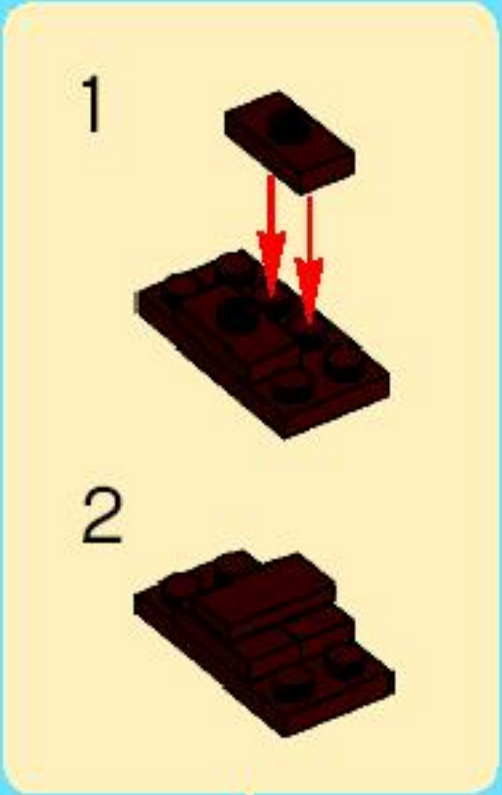

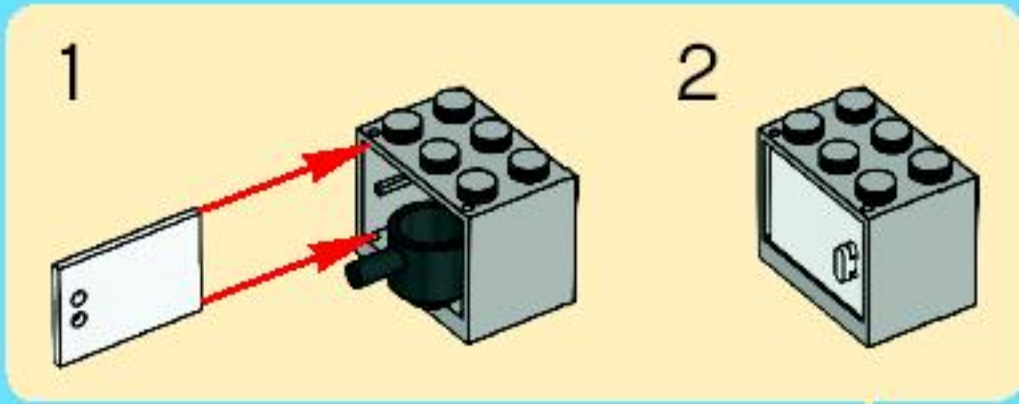
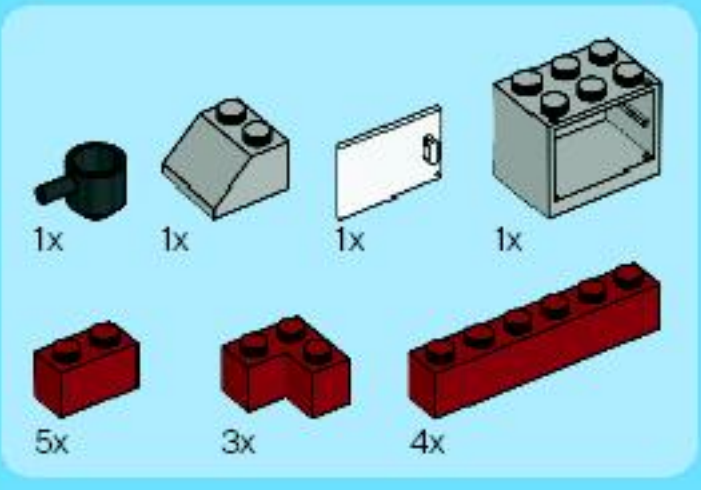

19

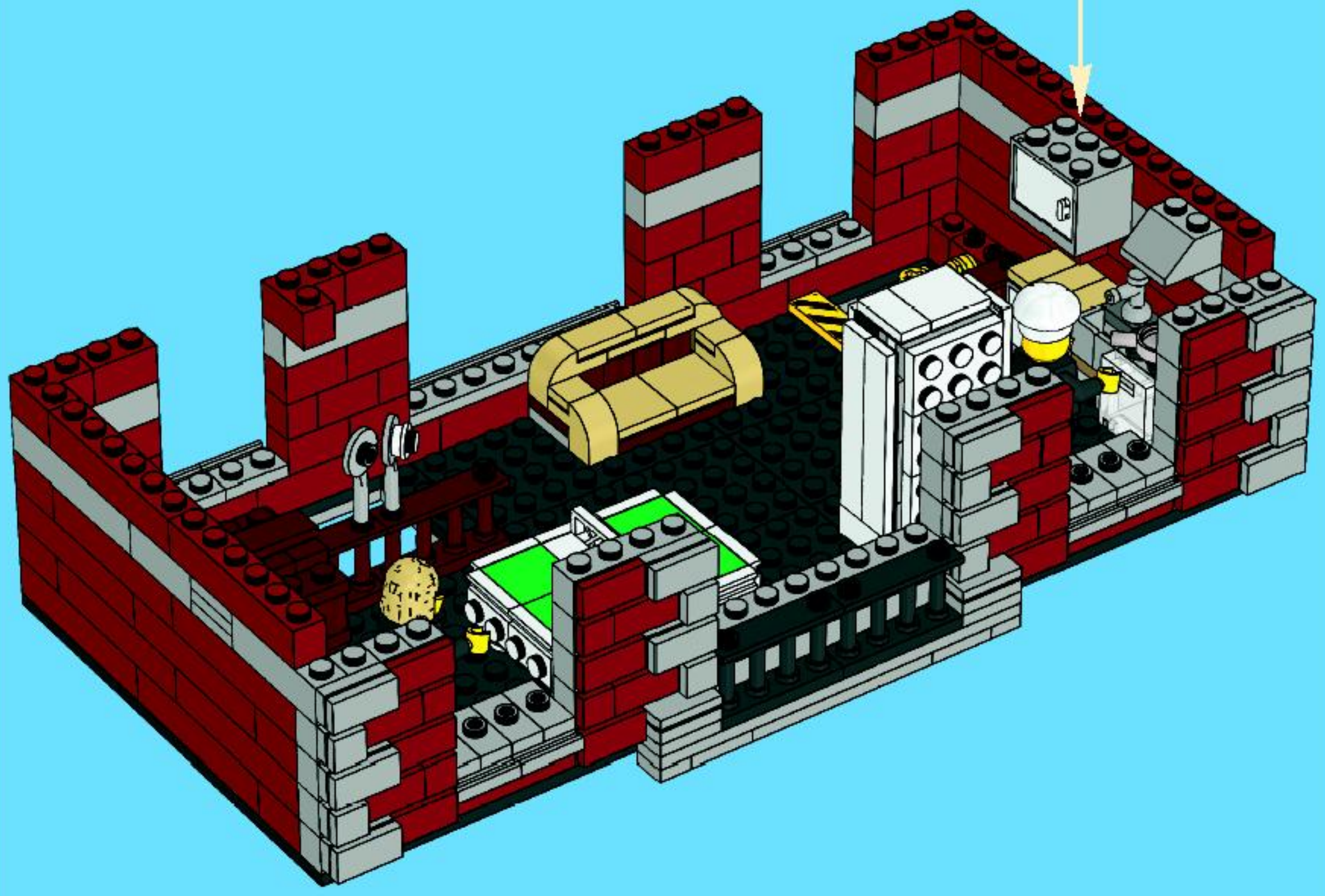

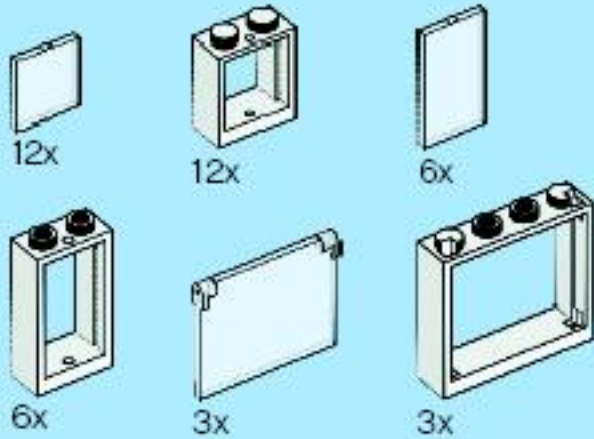

20

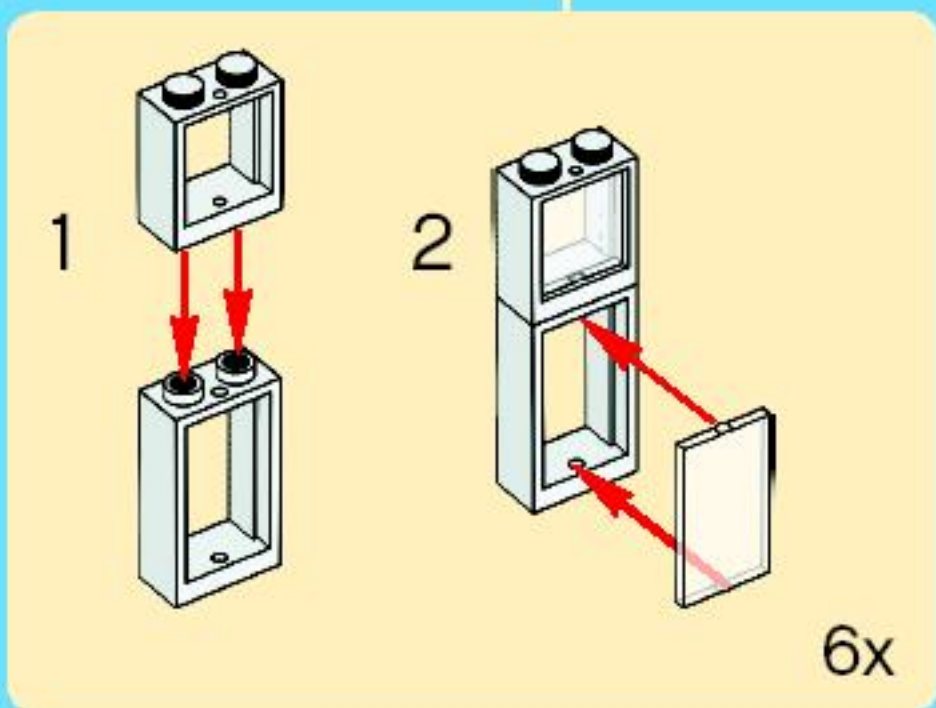
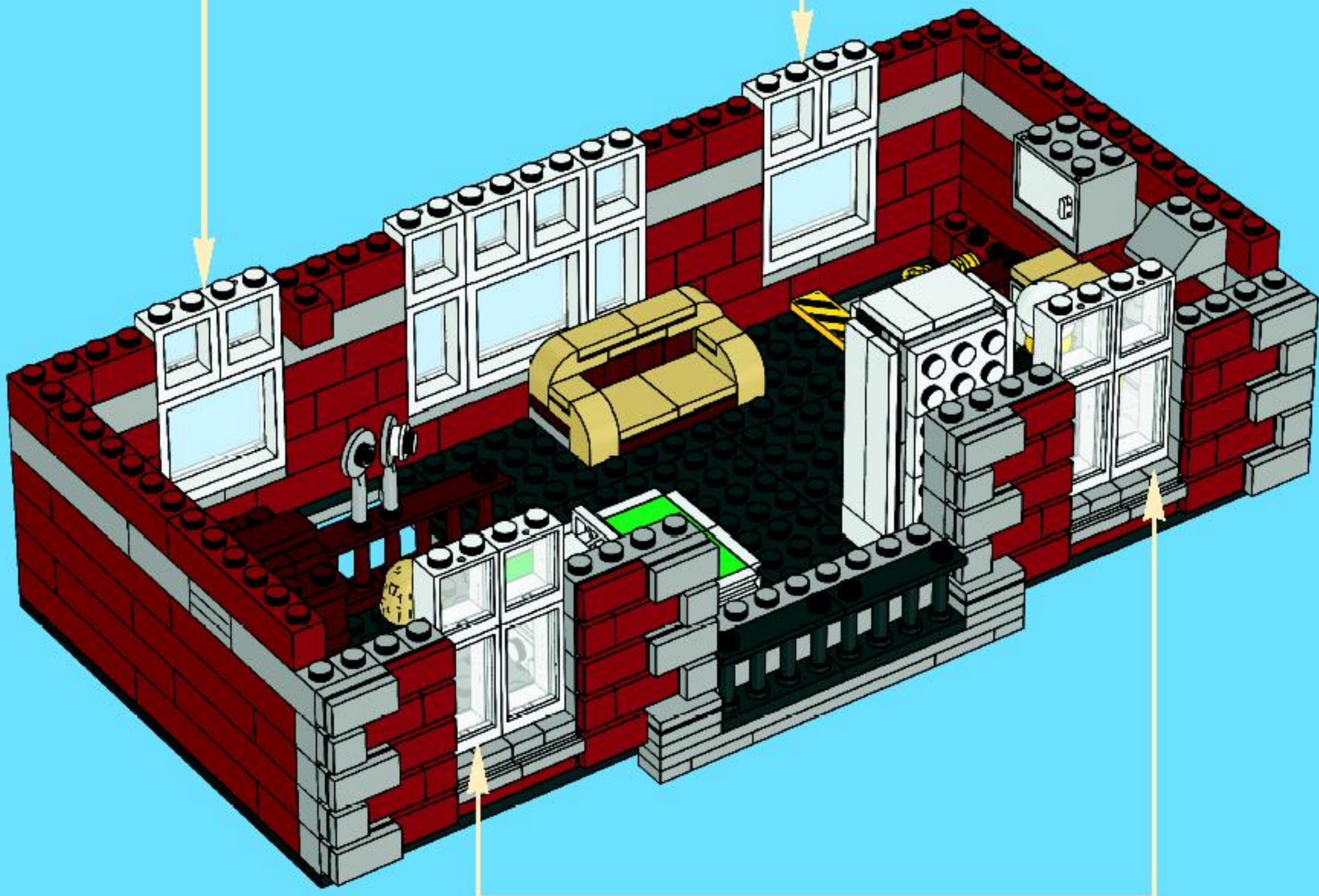
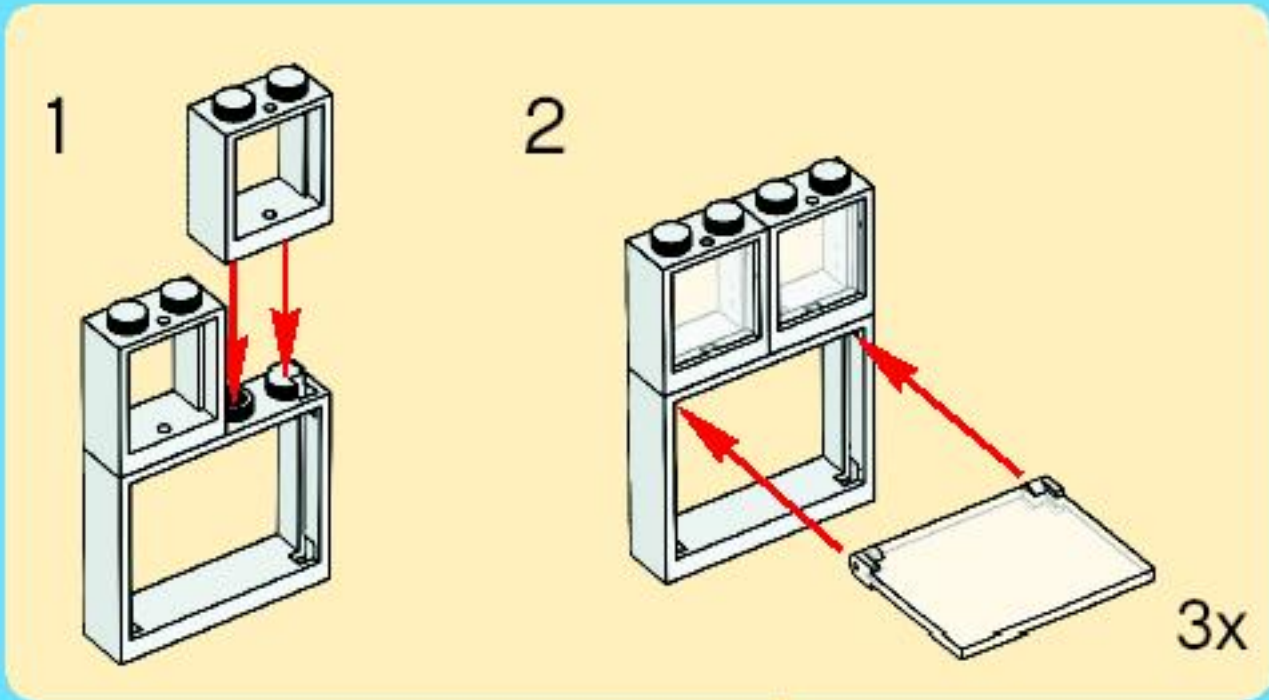

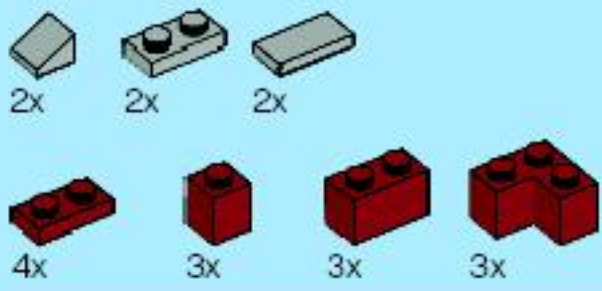

21

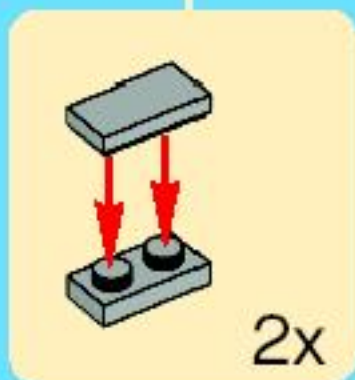
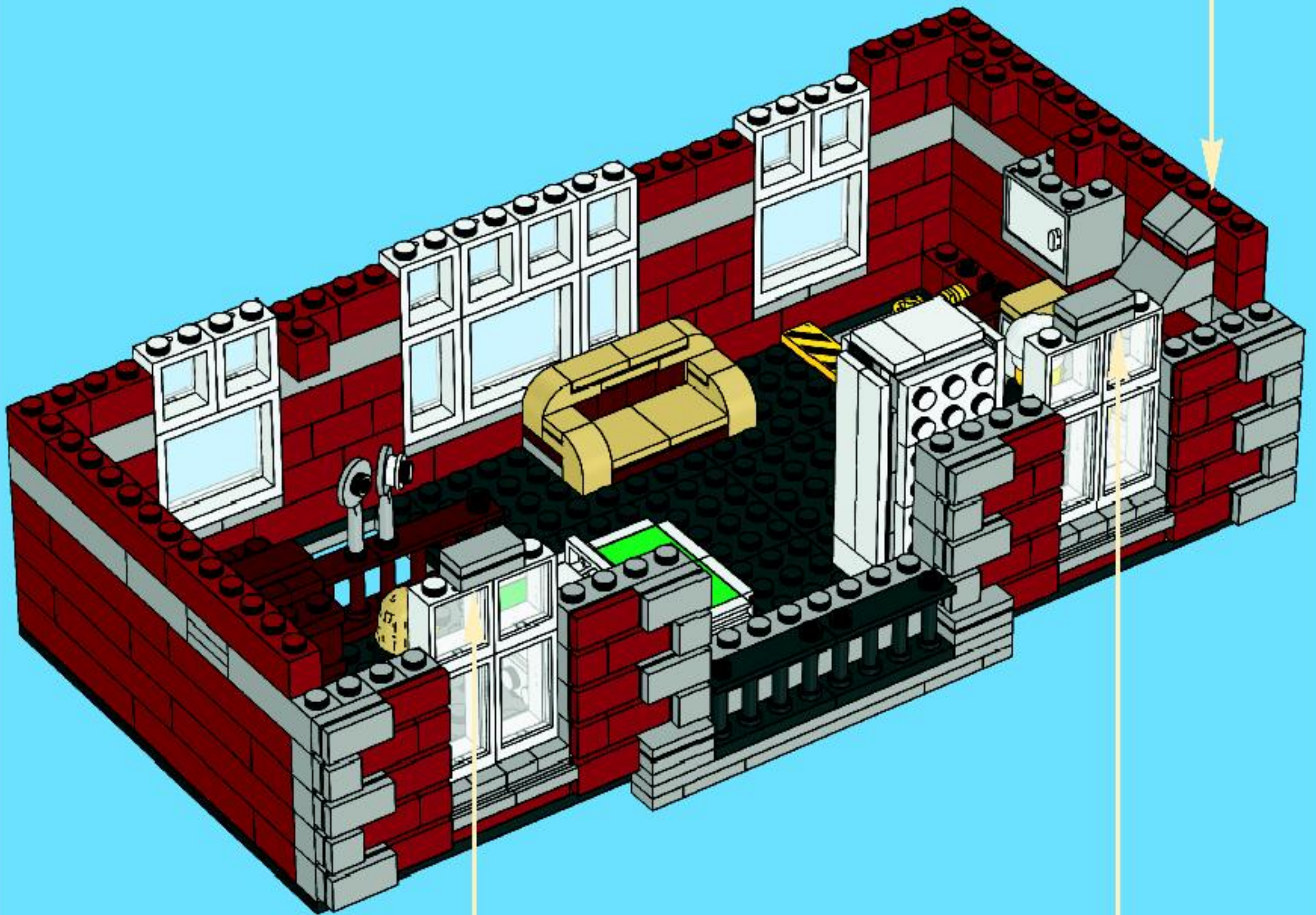
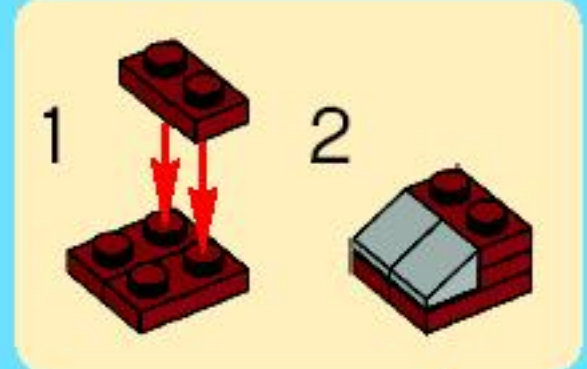

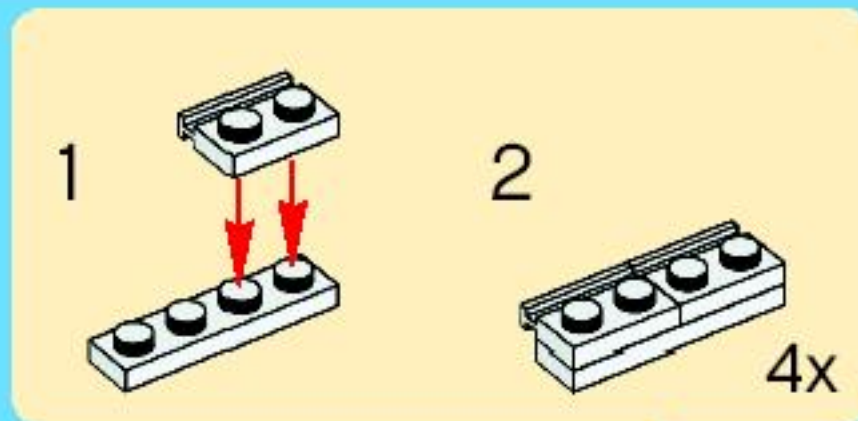
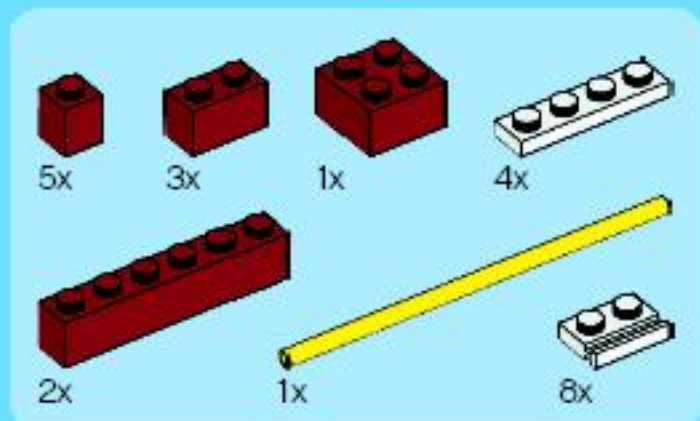

22

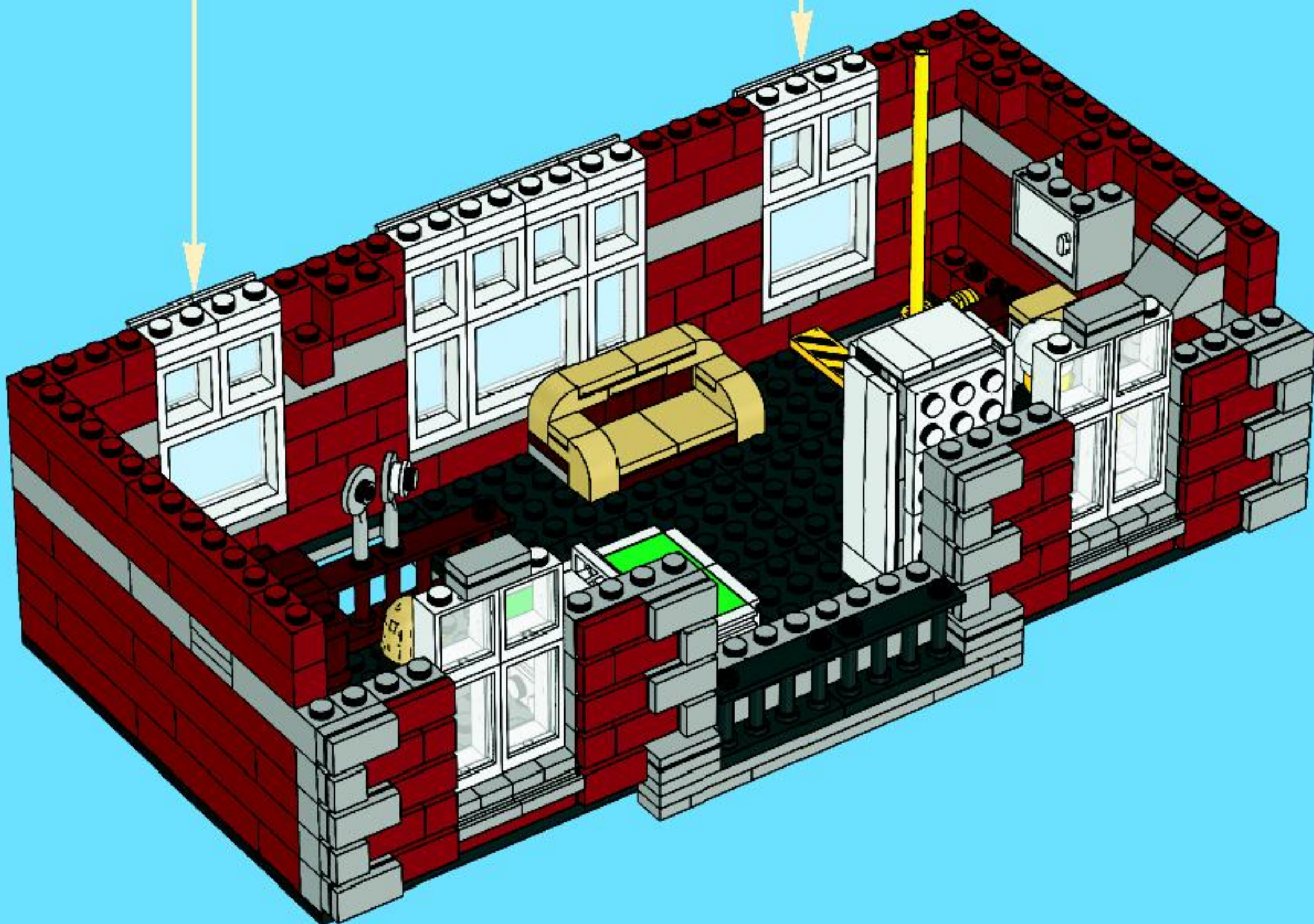

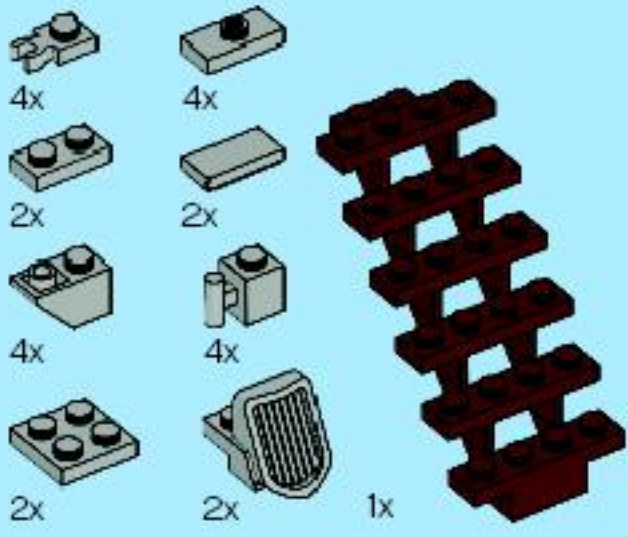

23

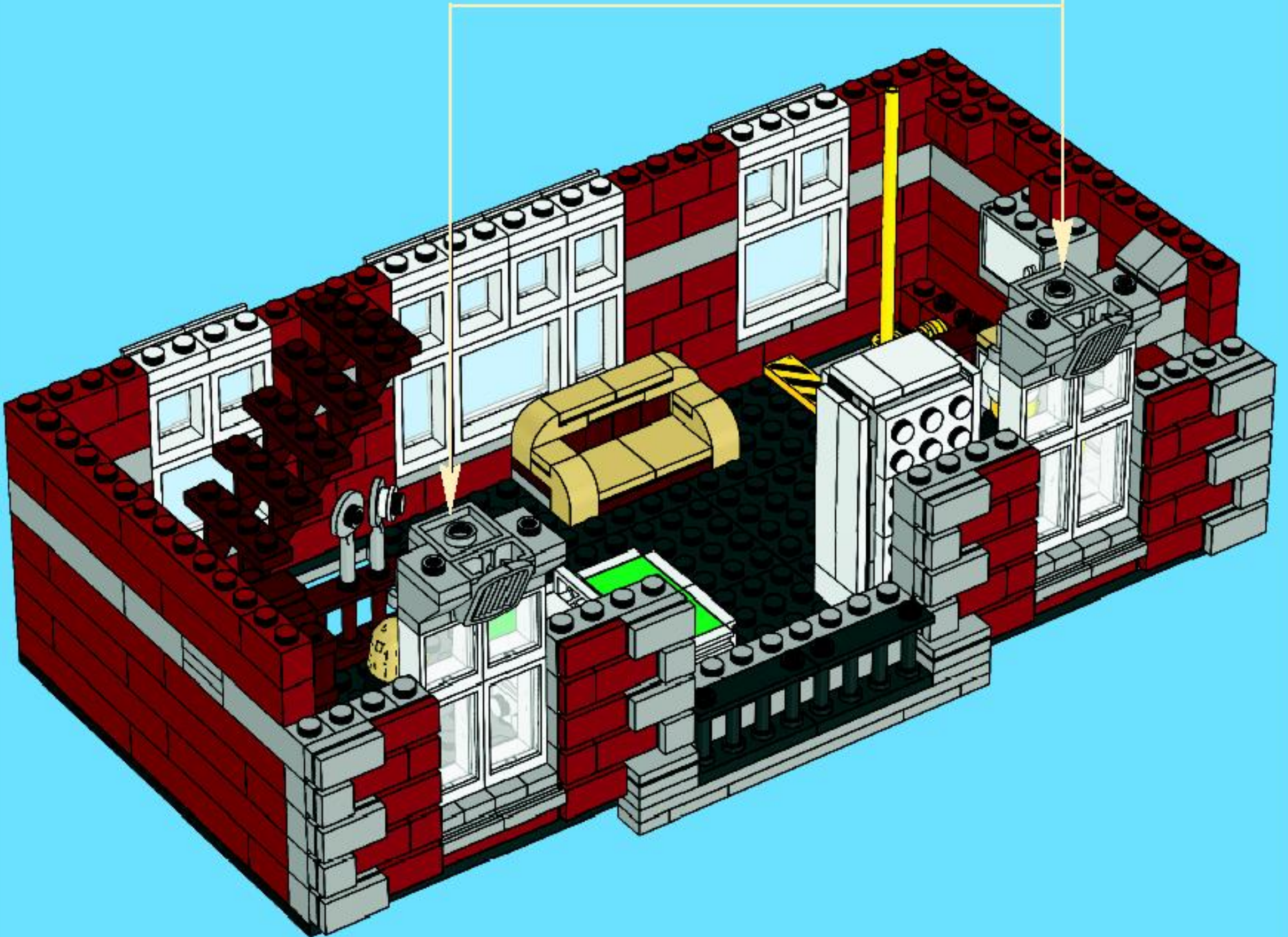
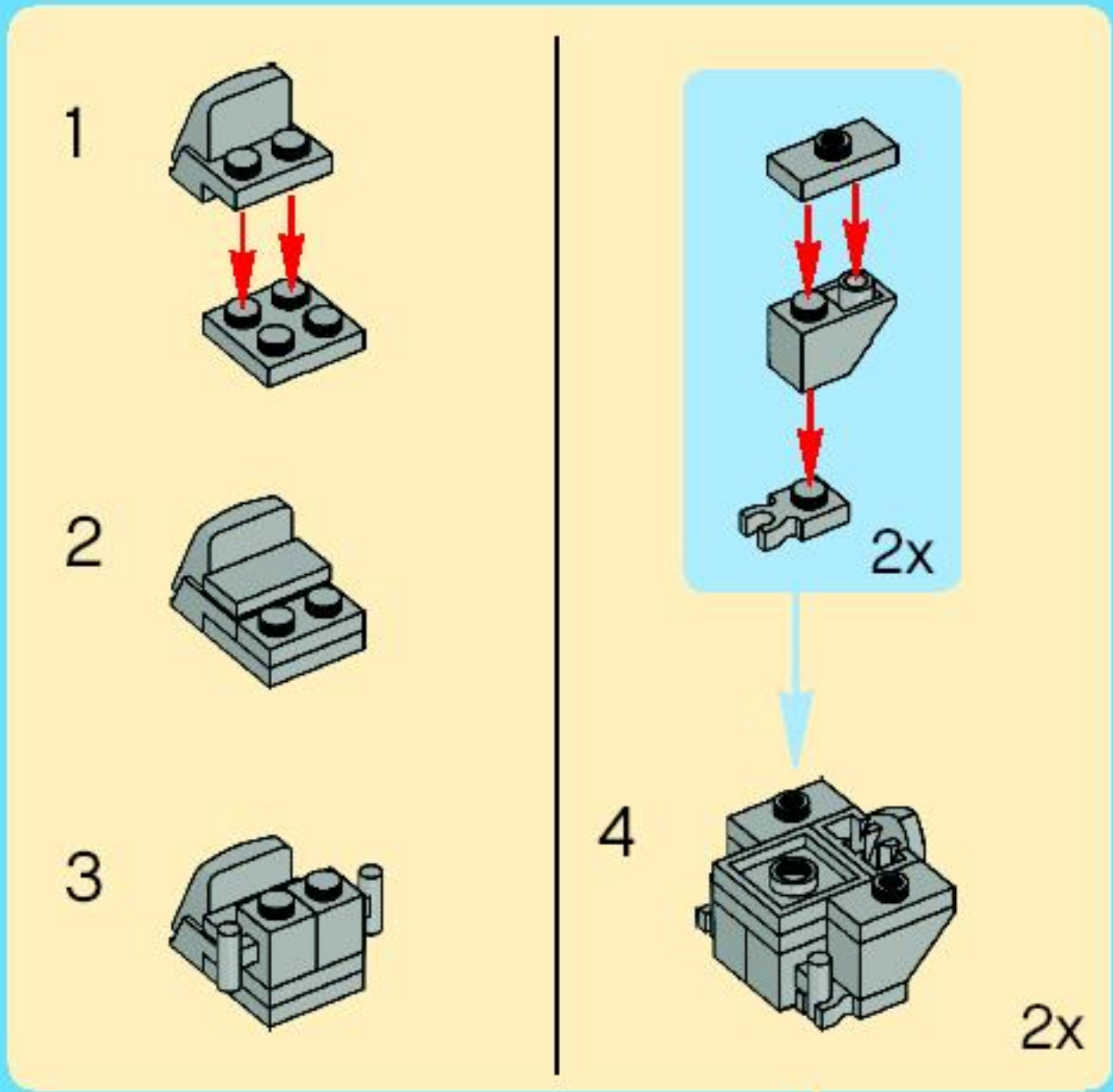

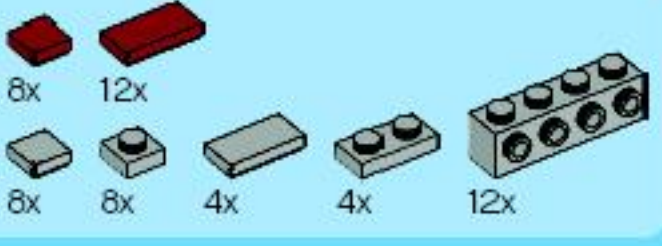

24

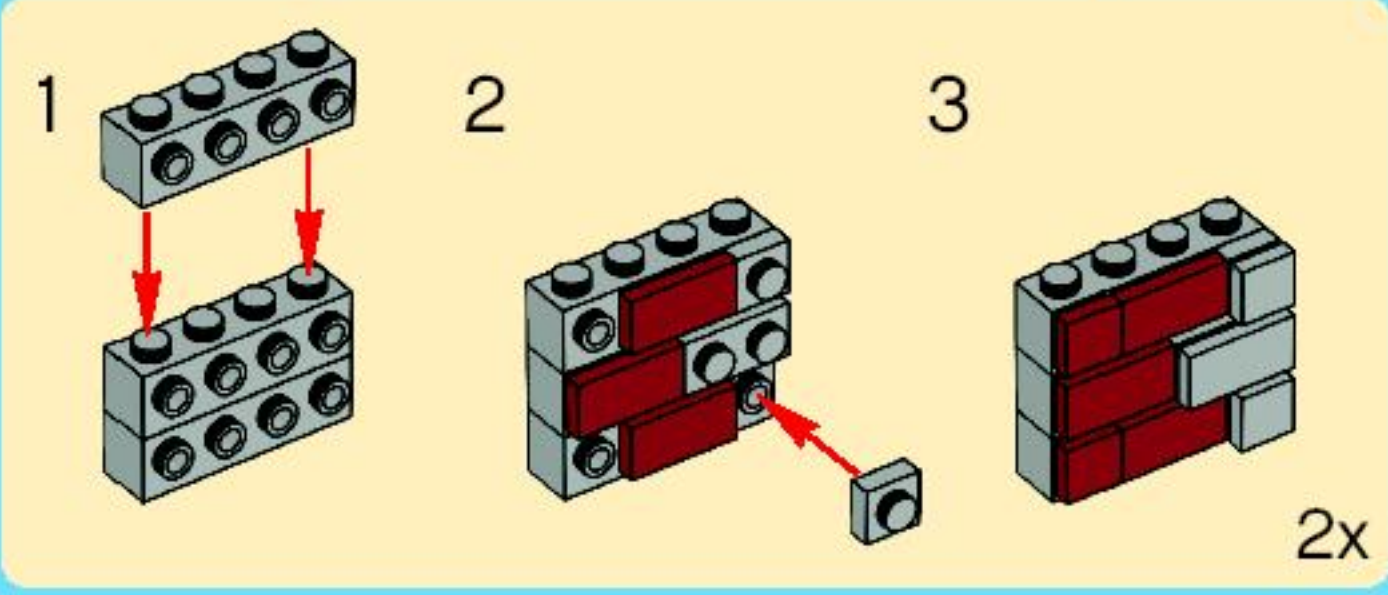
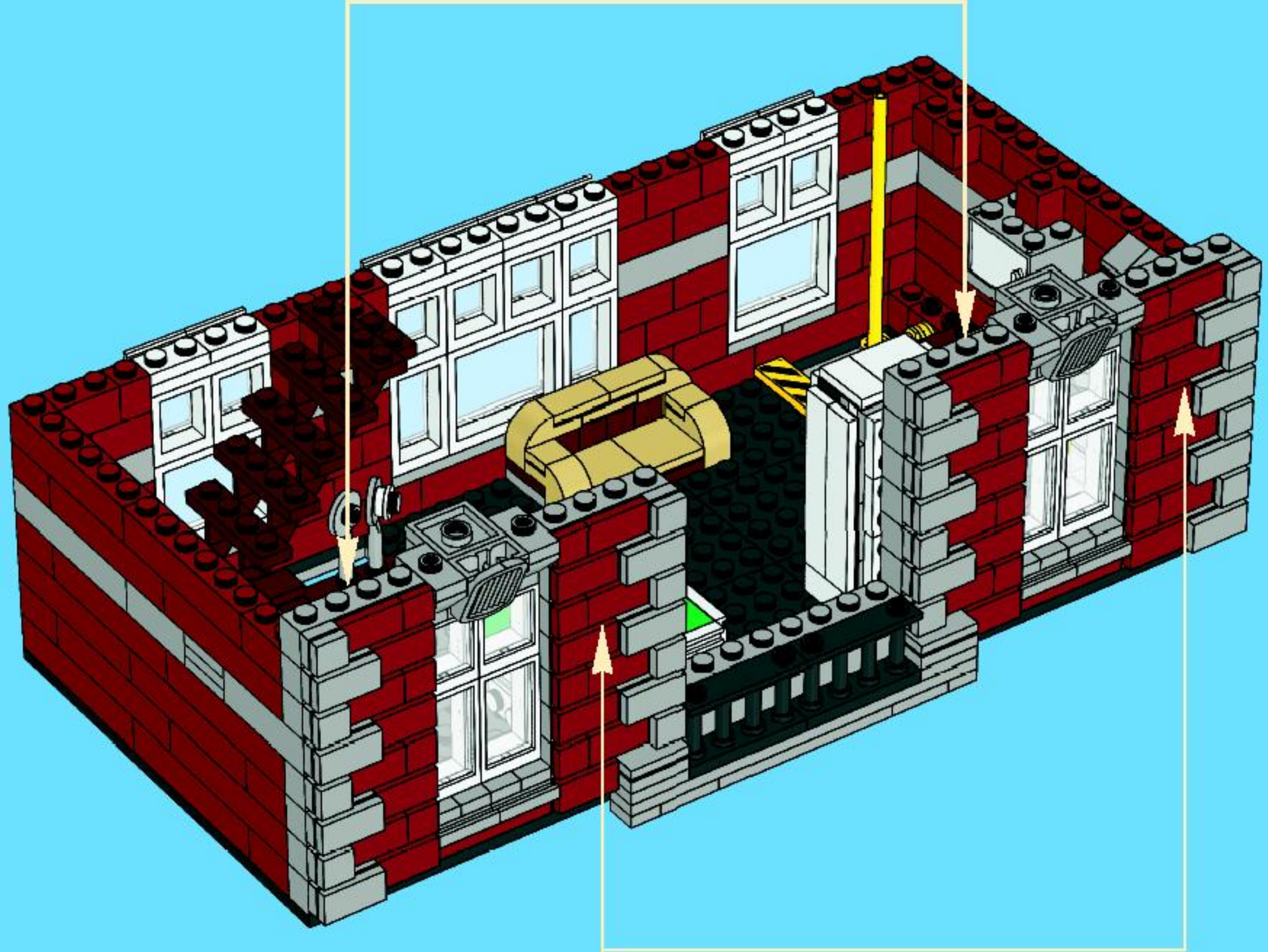
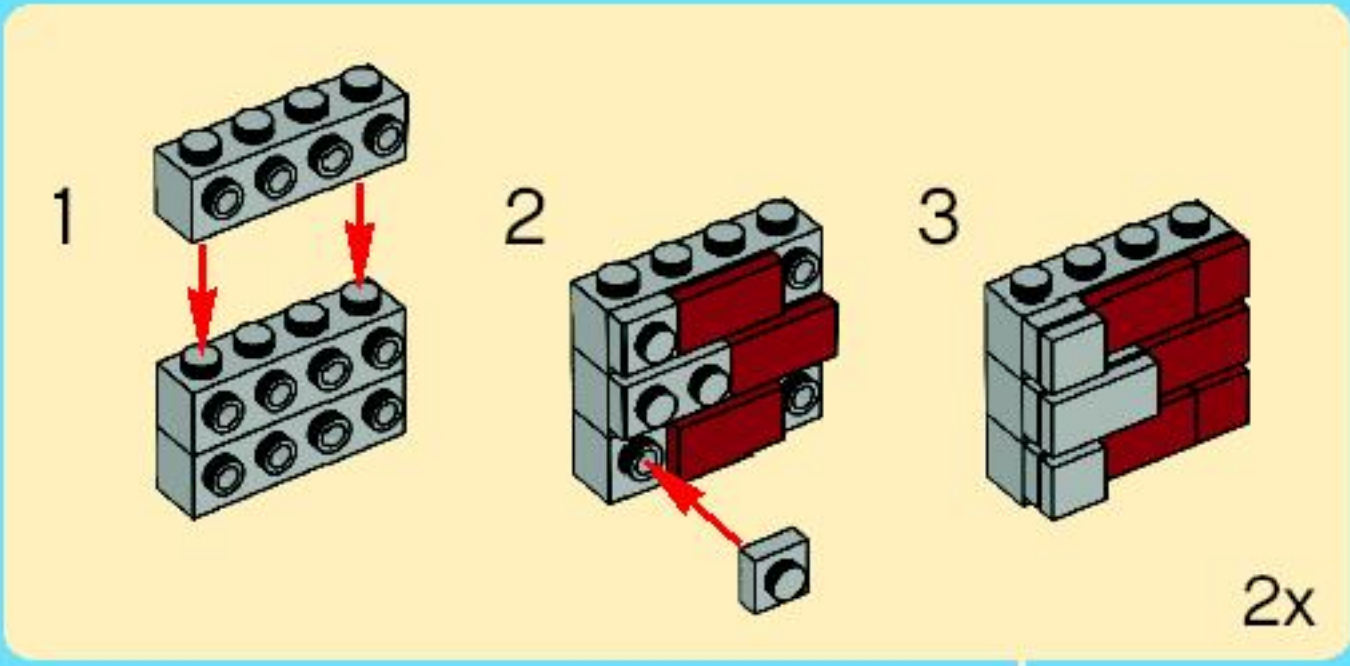

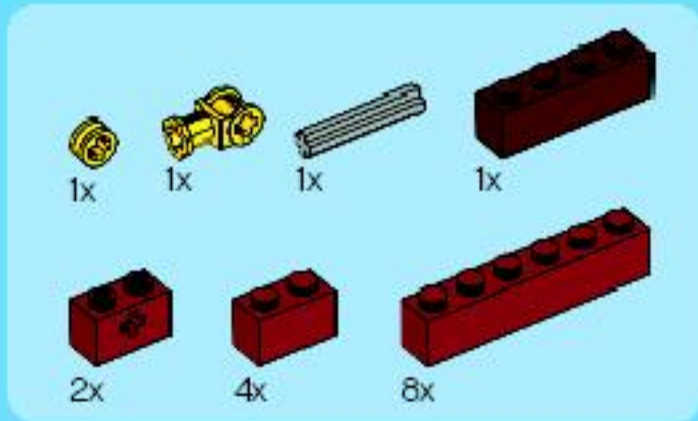

25

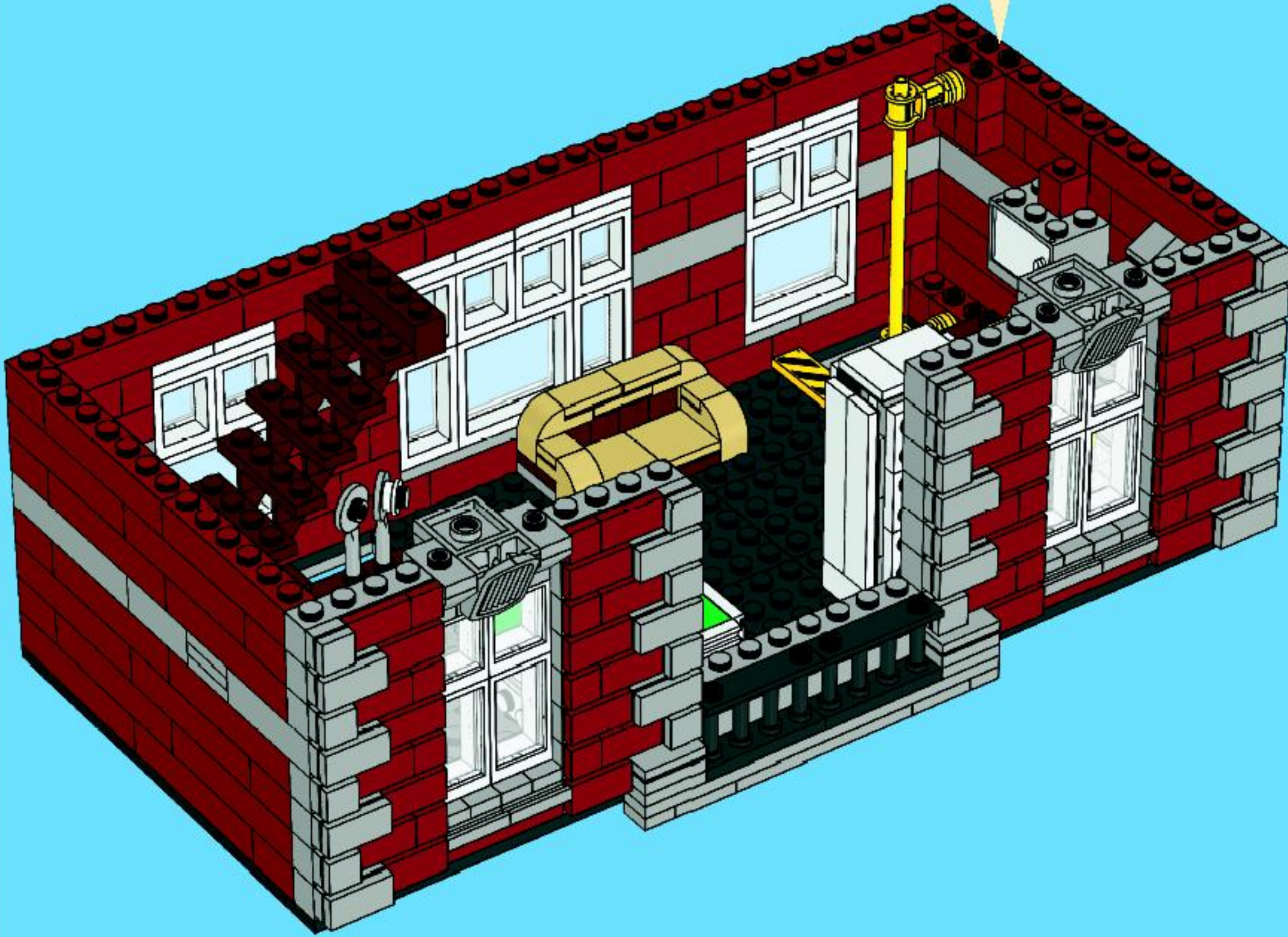
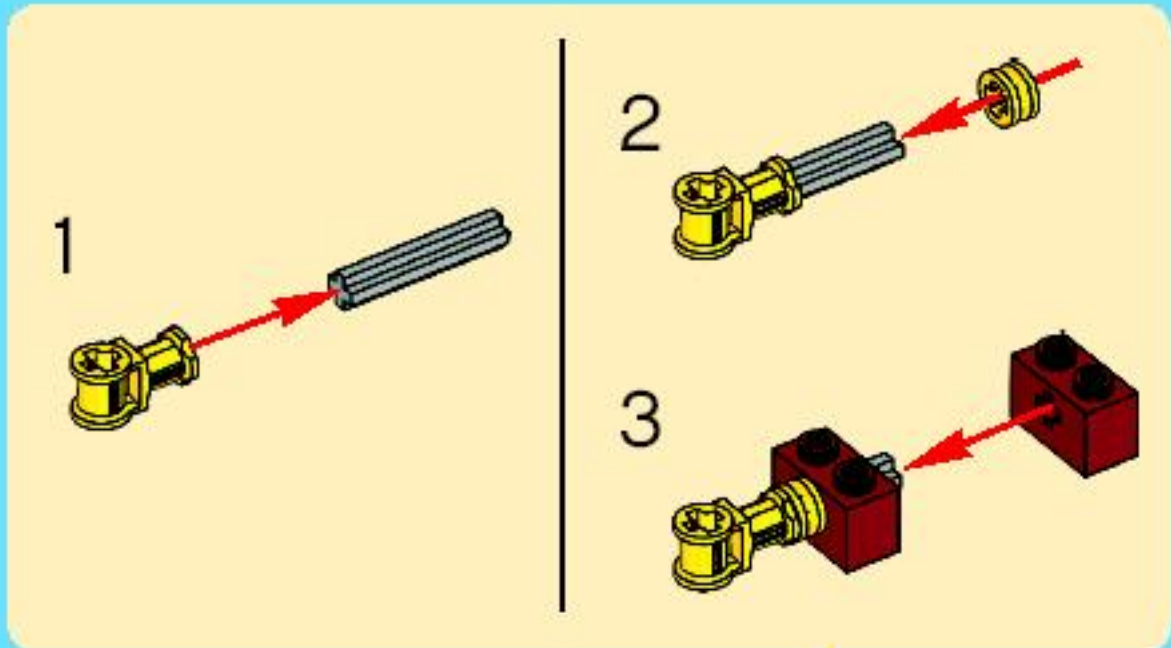

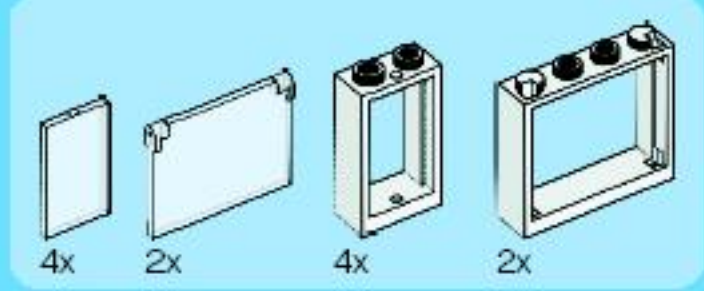

26

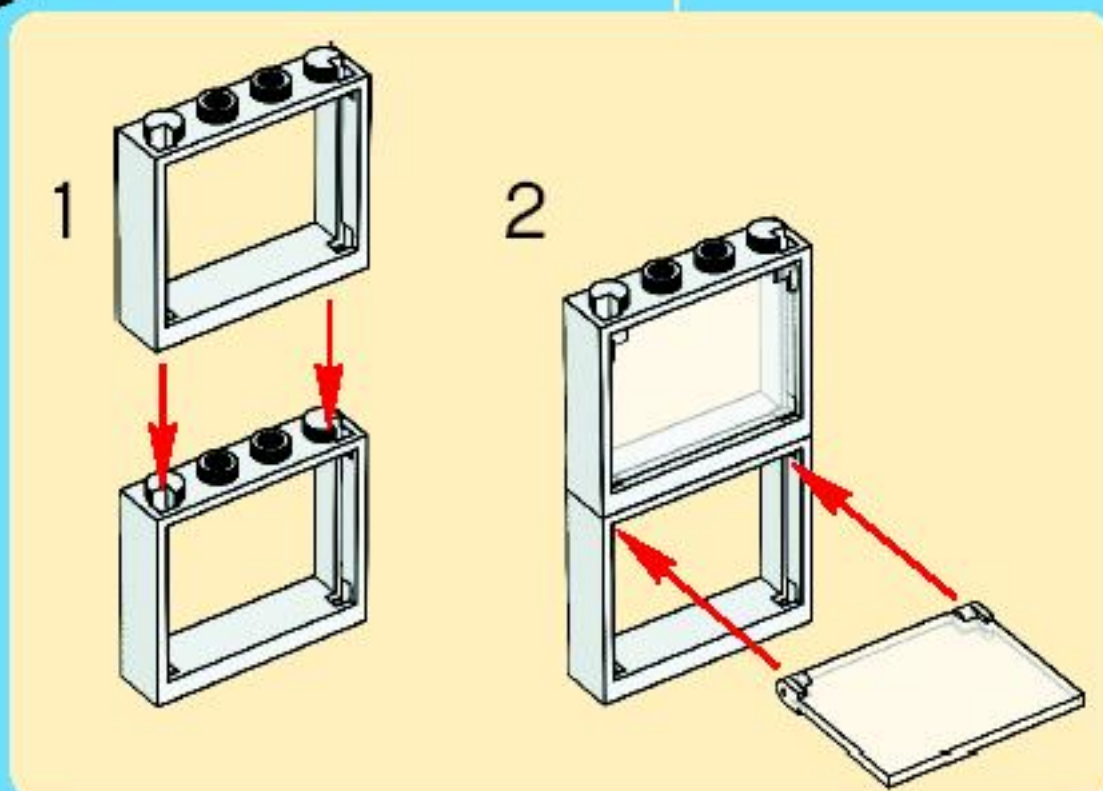
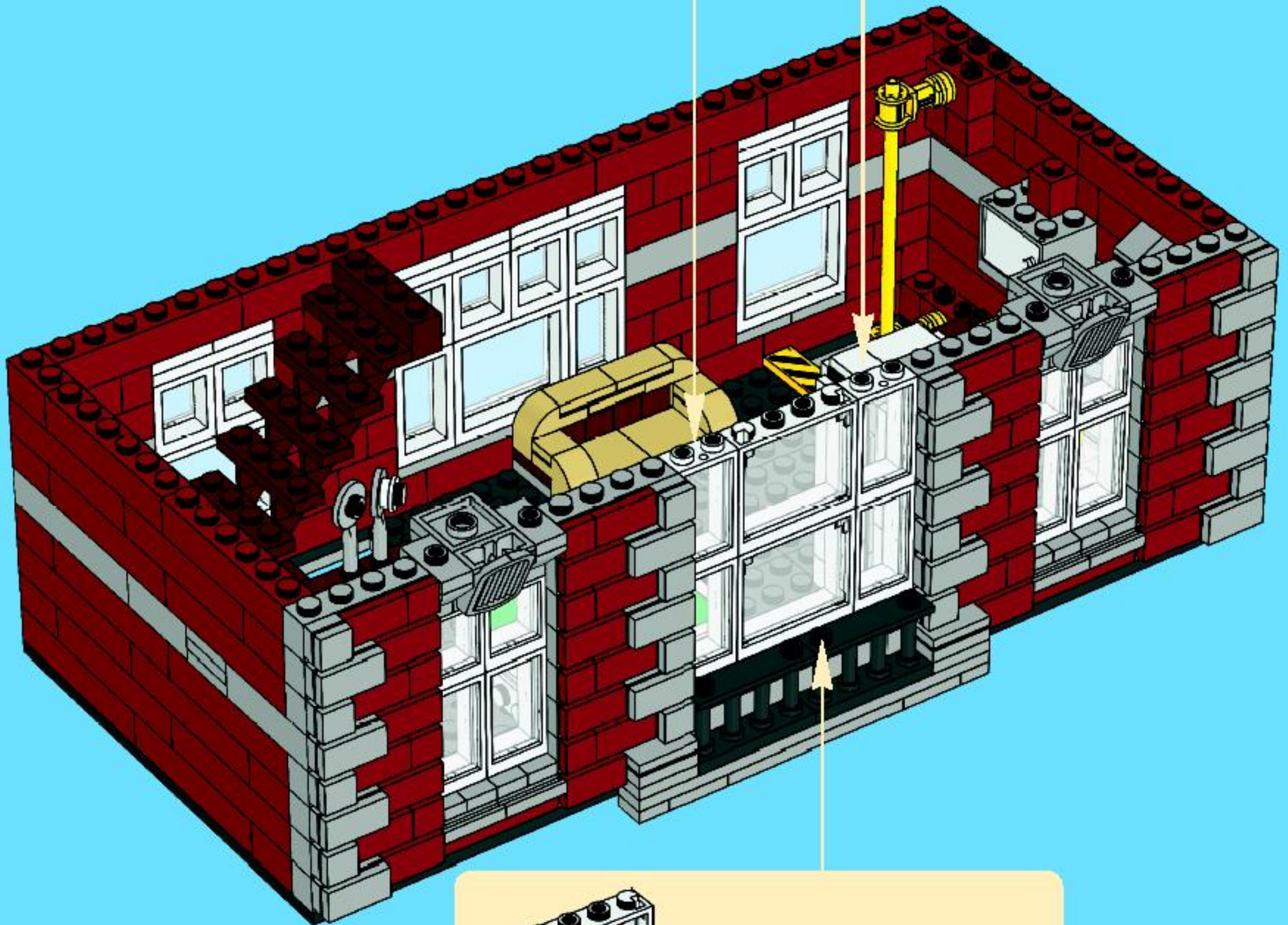
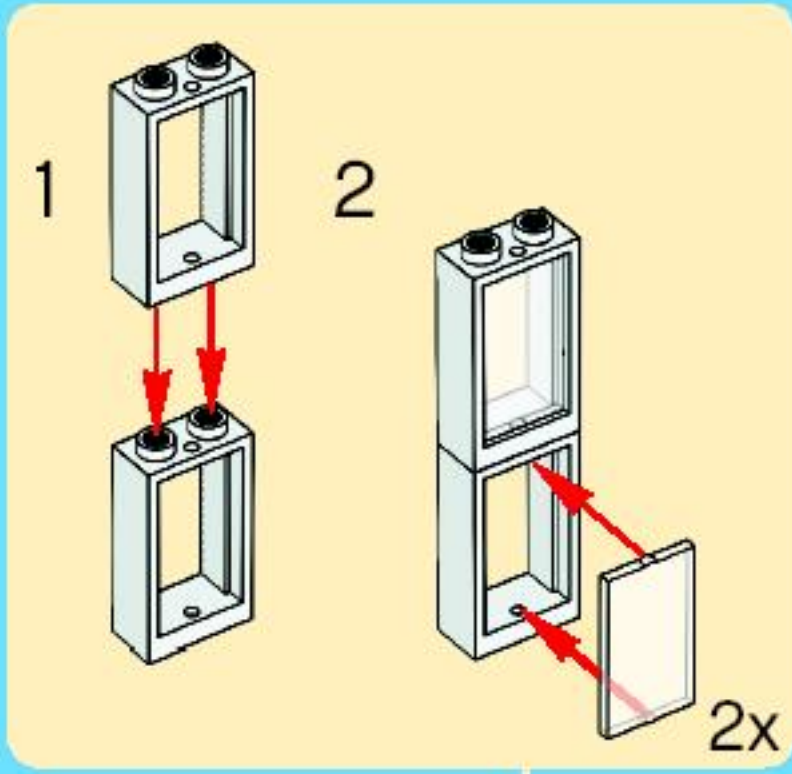

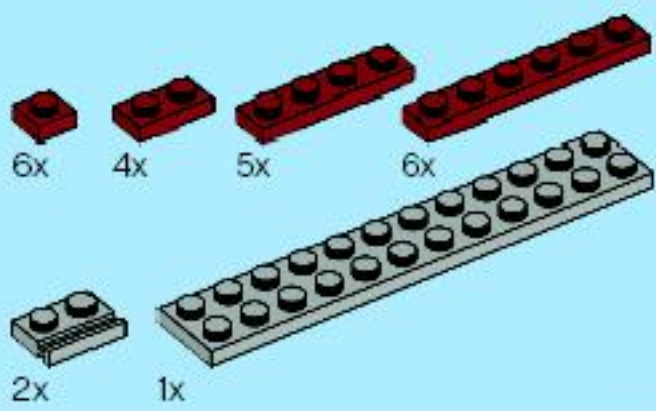

27

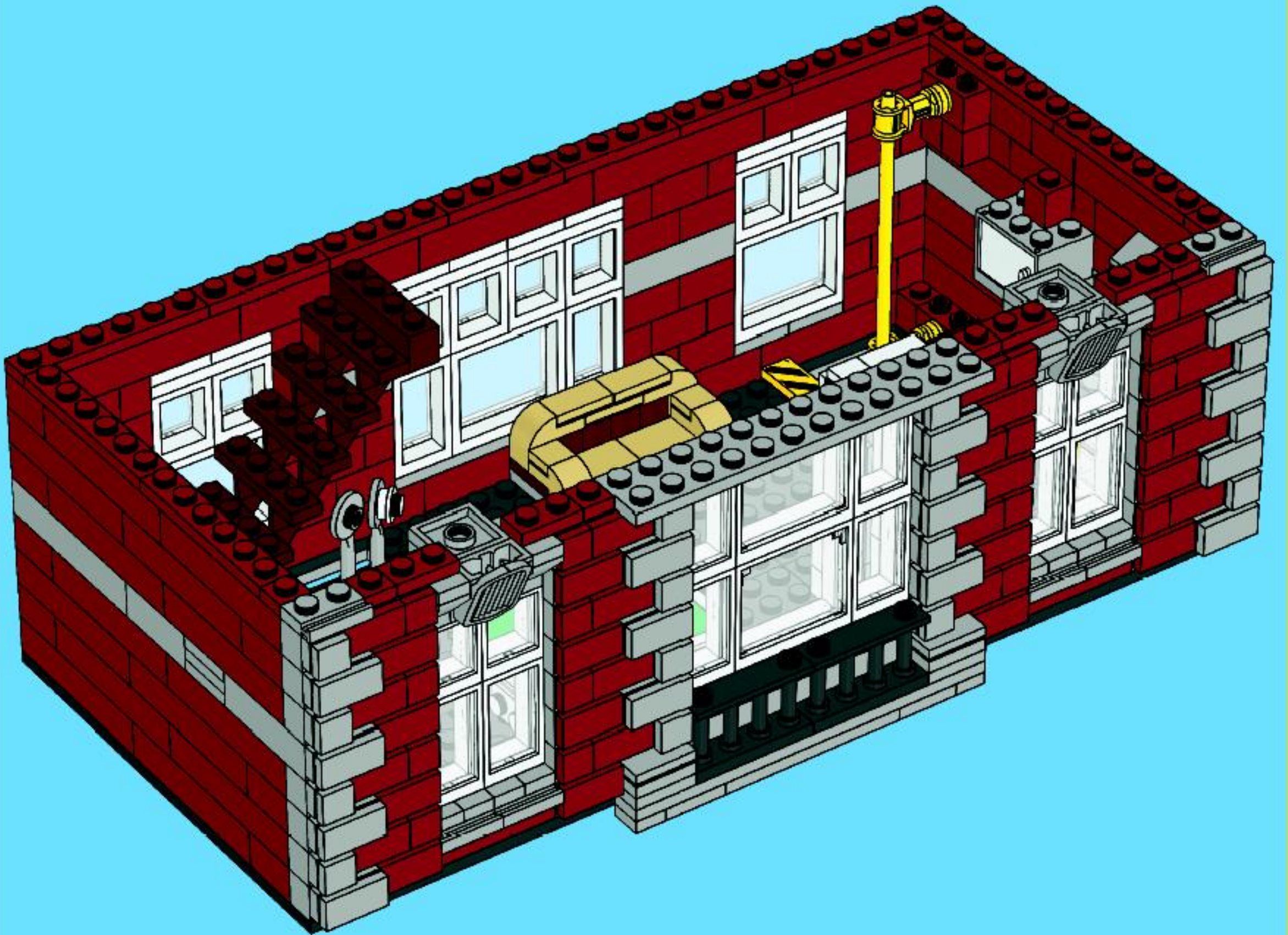

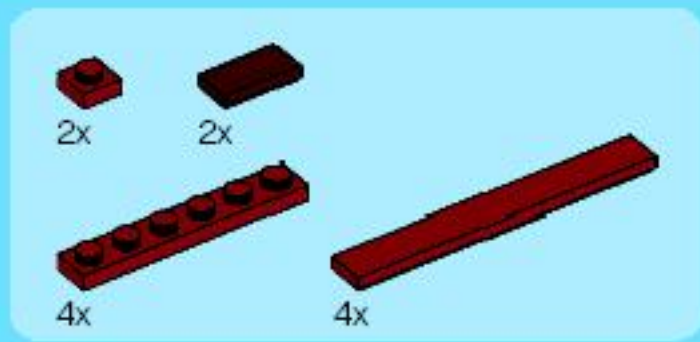

28

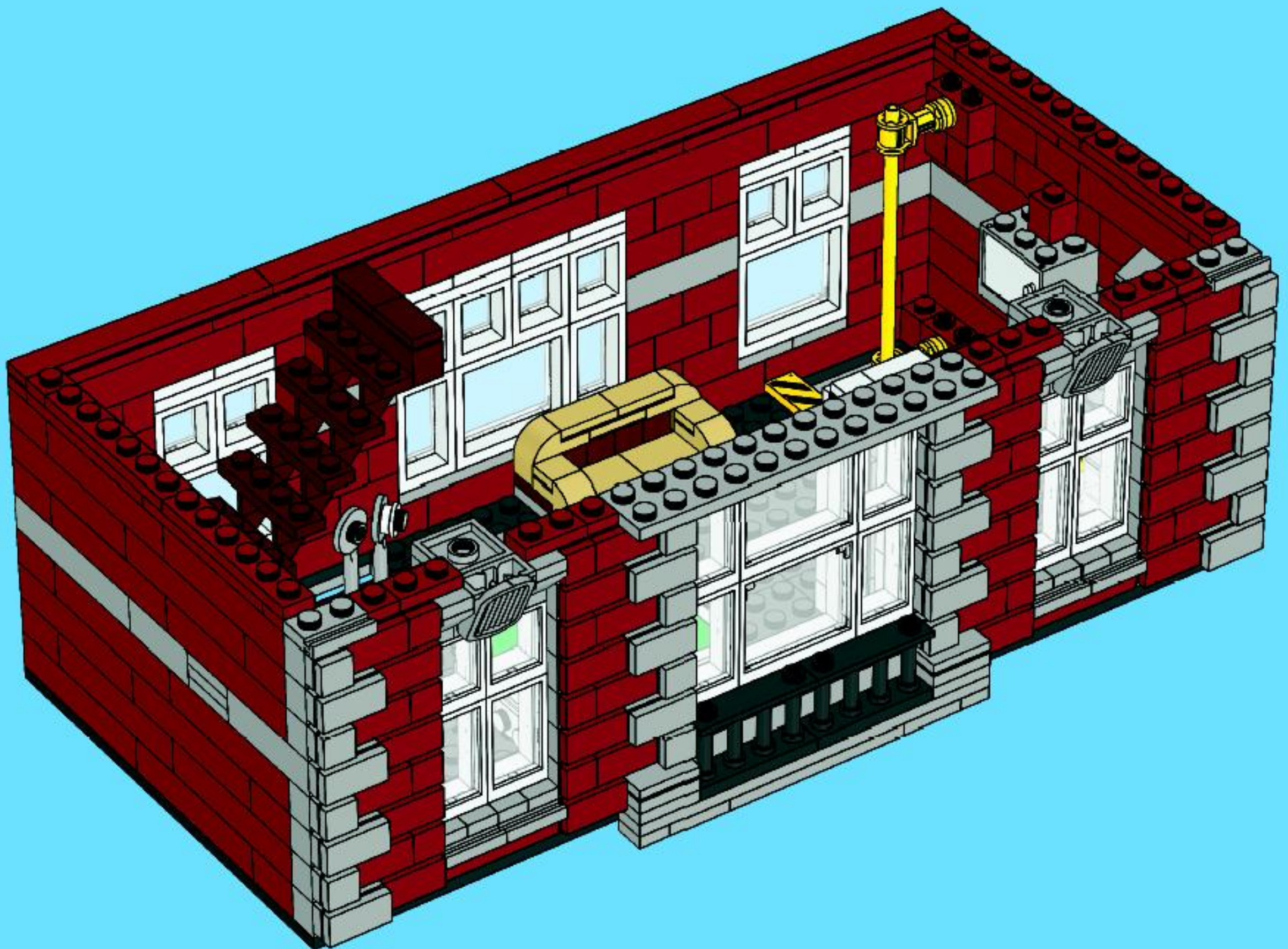

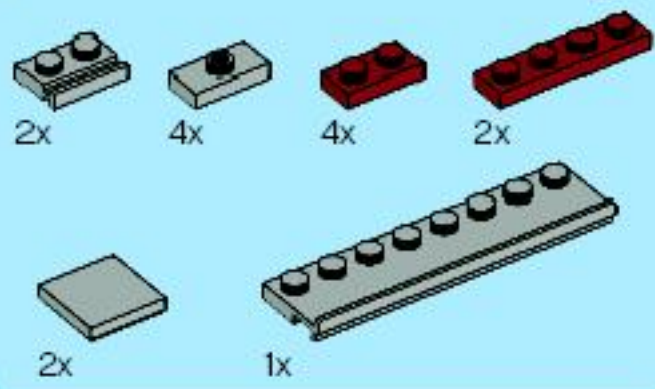

29

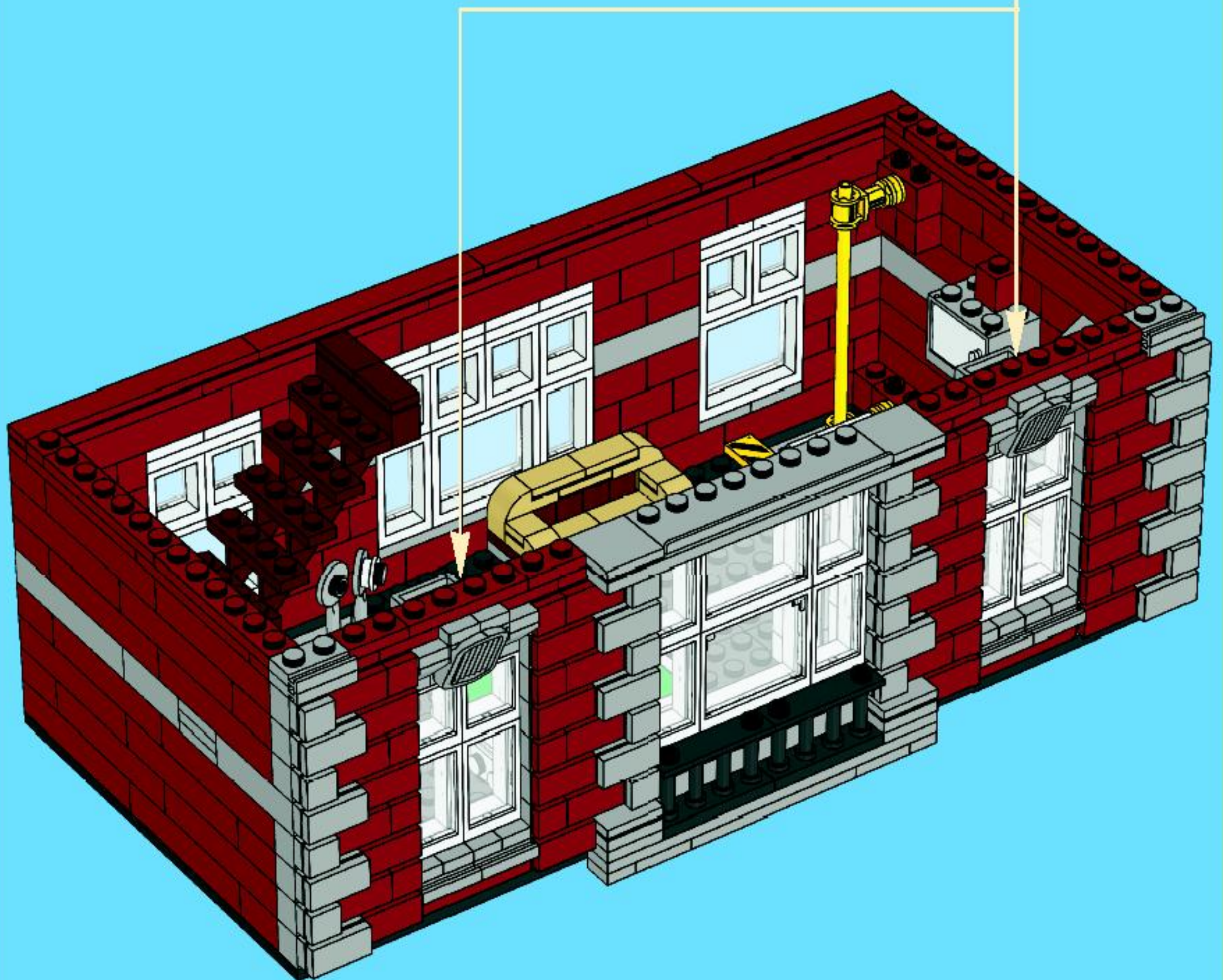
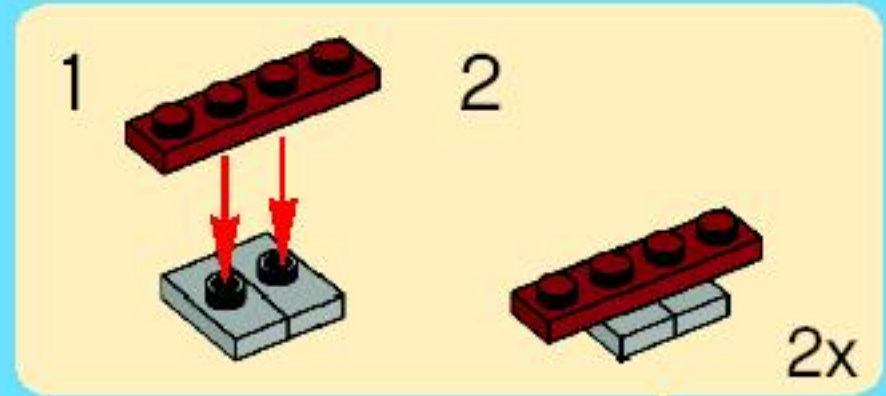

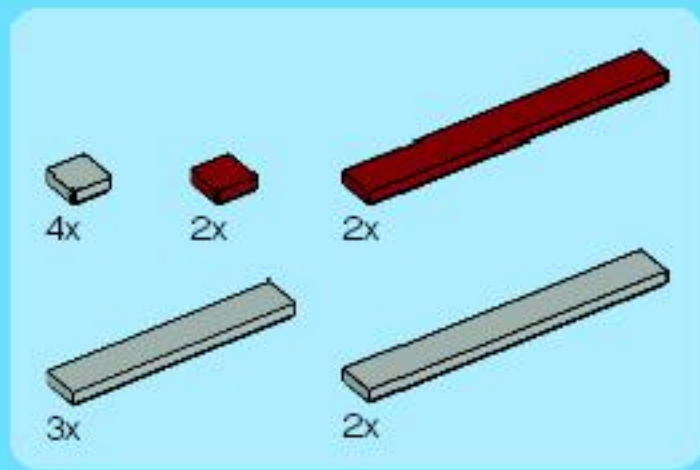

30

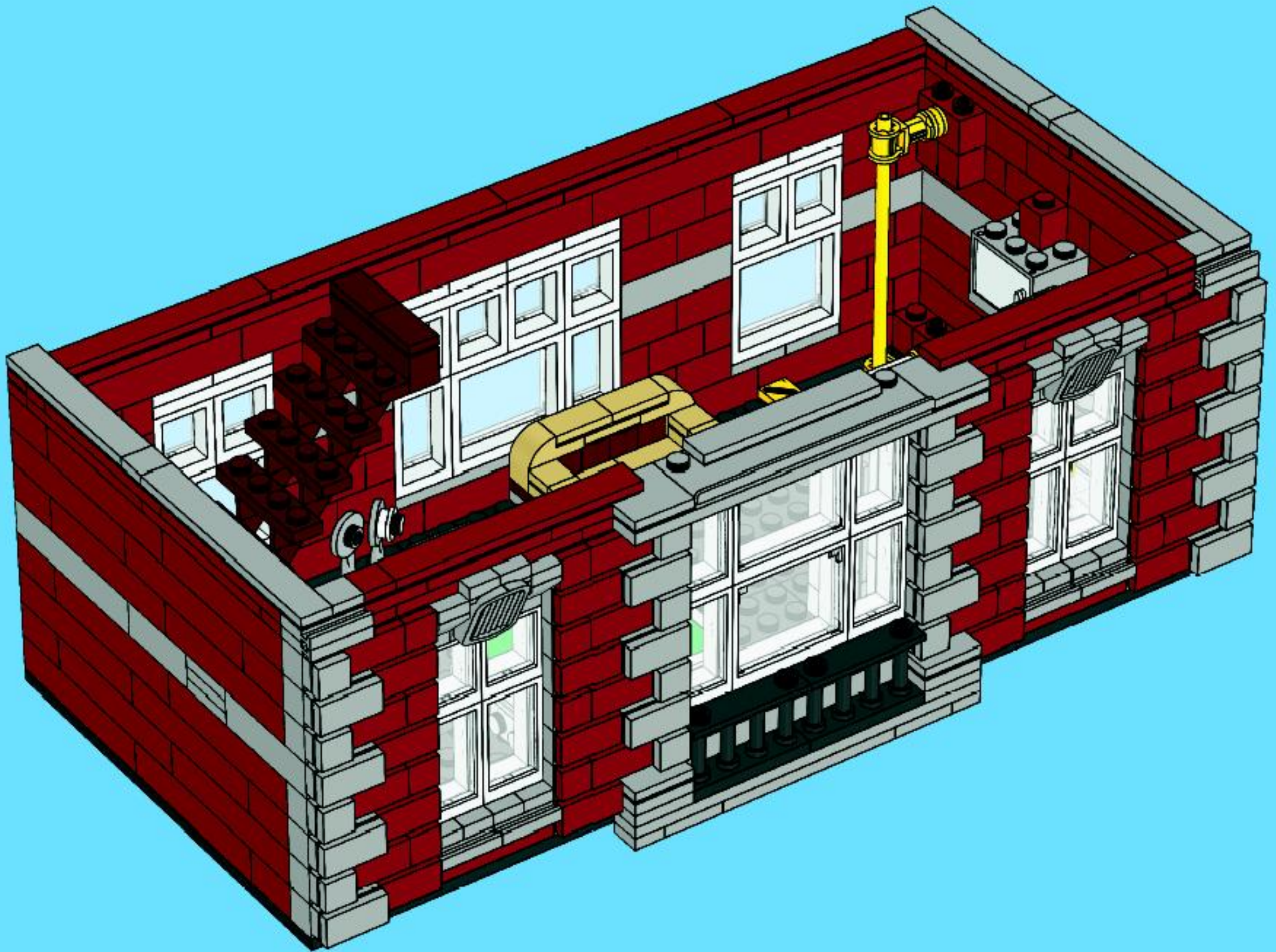



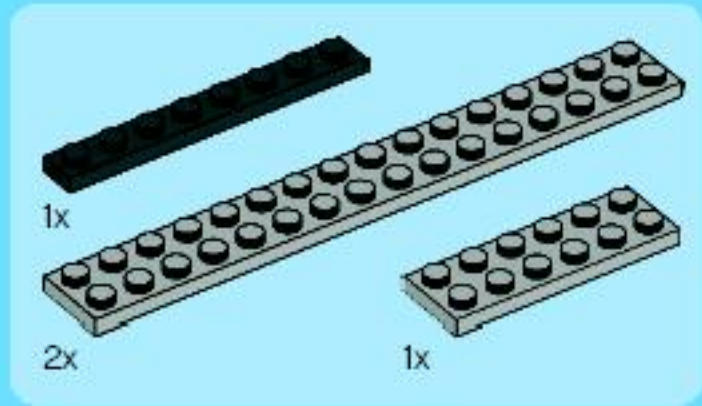
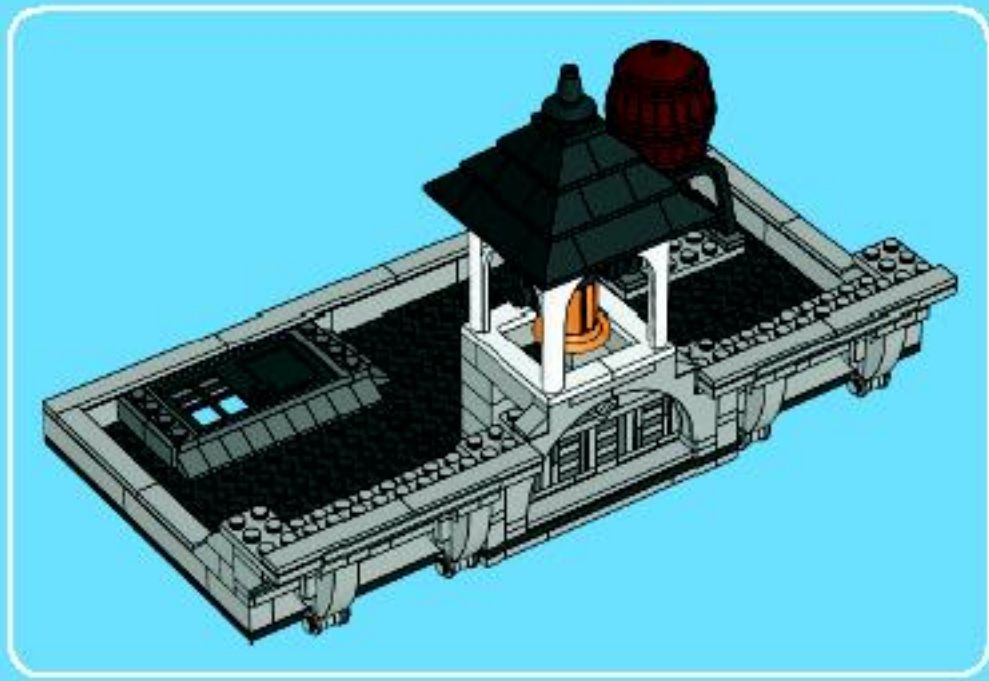

1

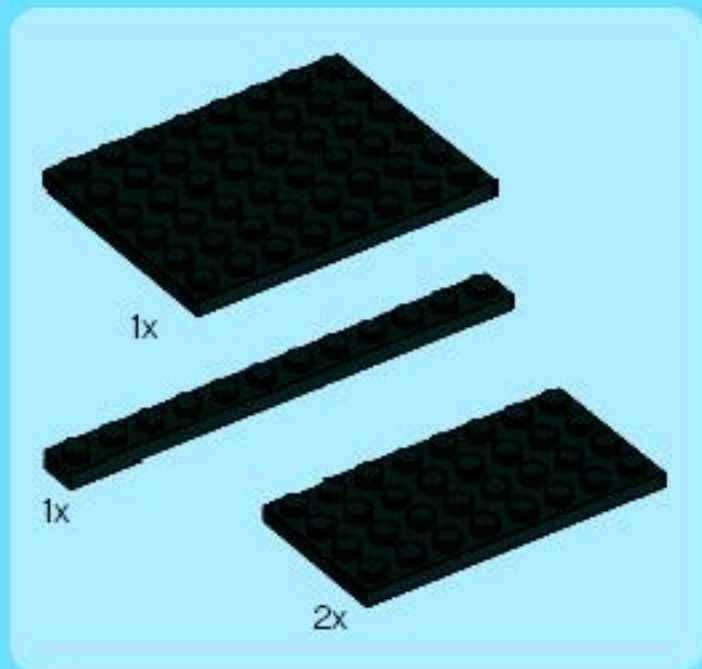
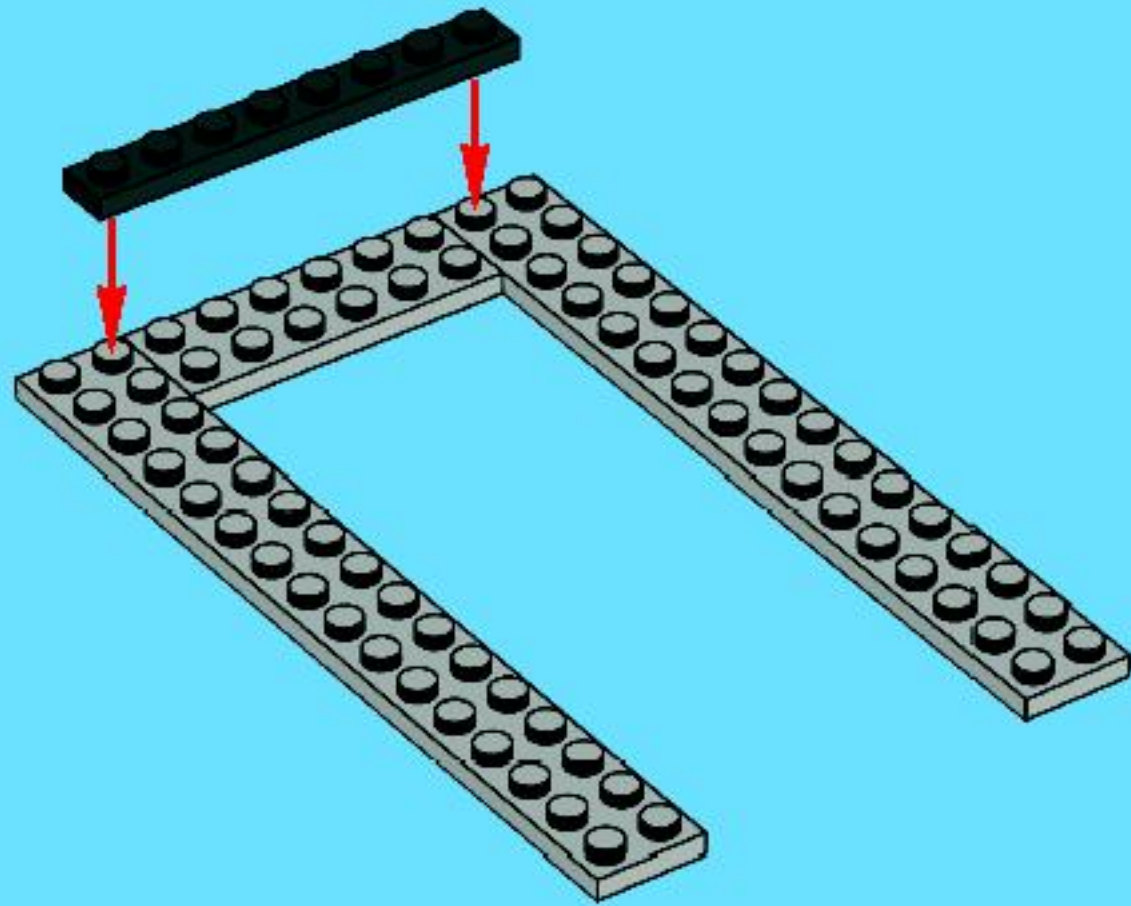

2

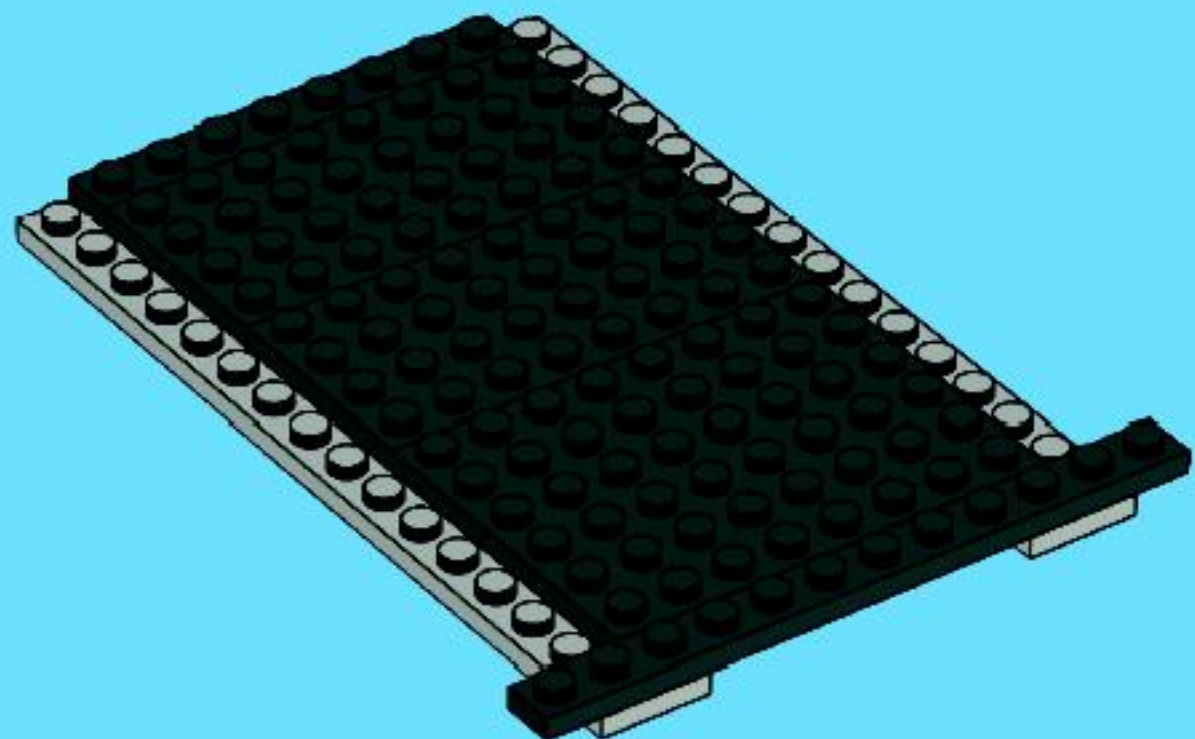

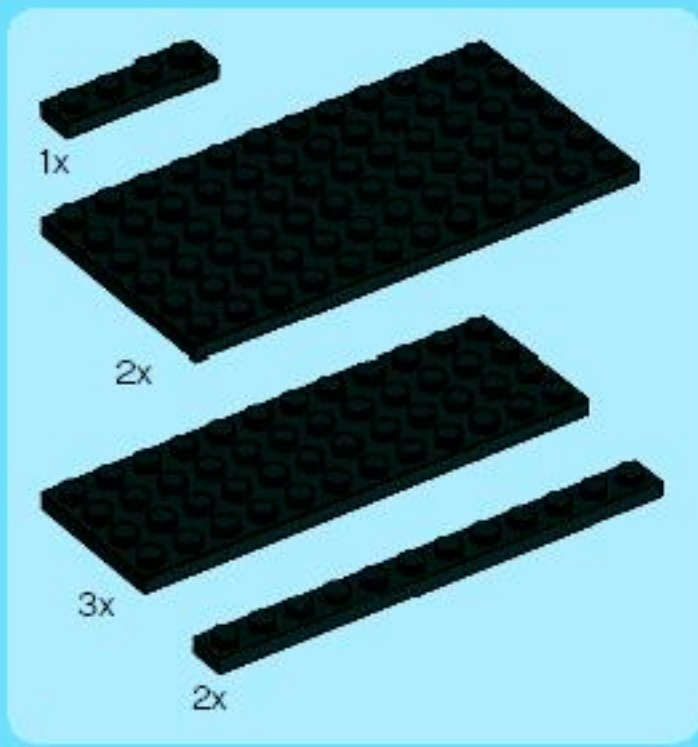

3

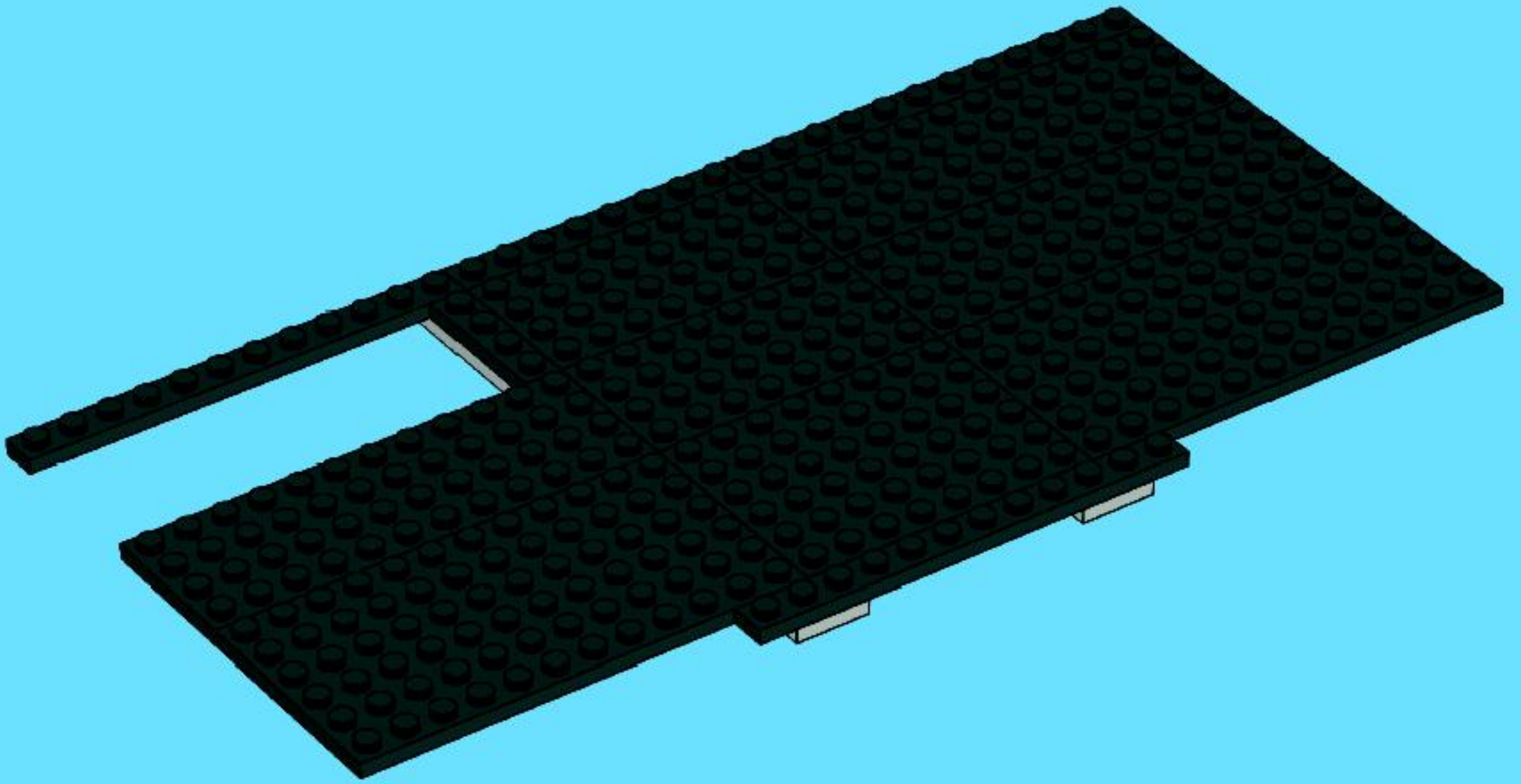

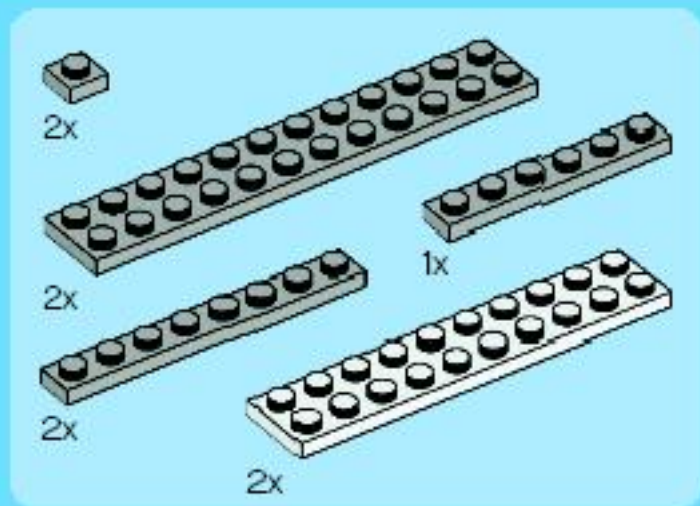

4

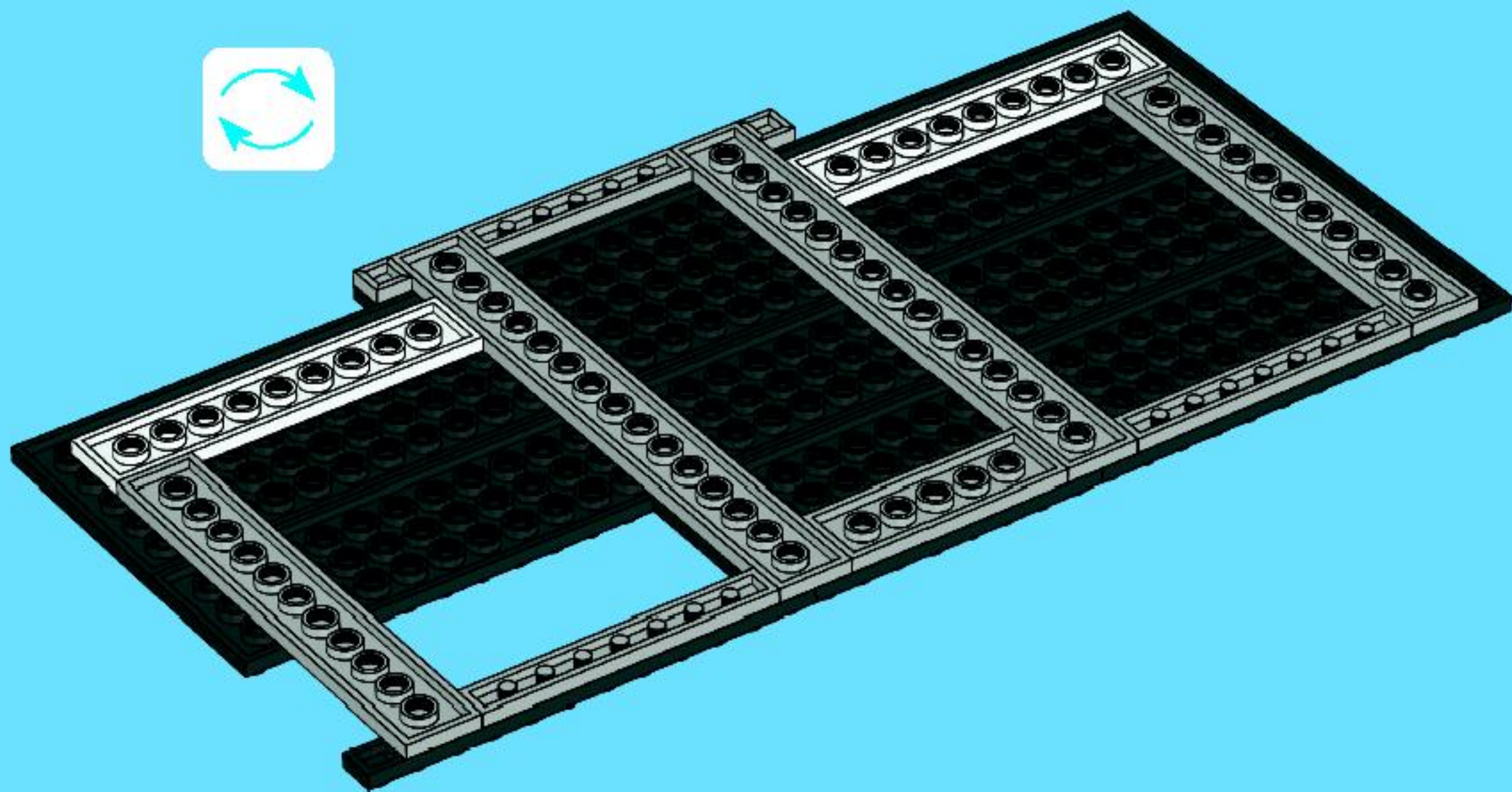

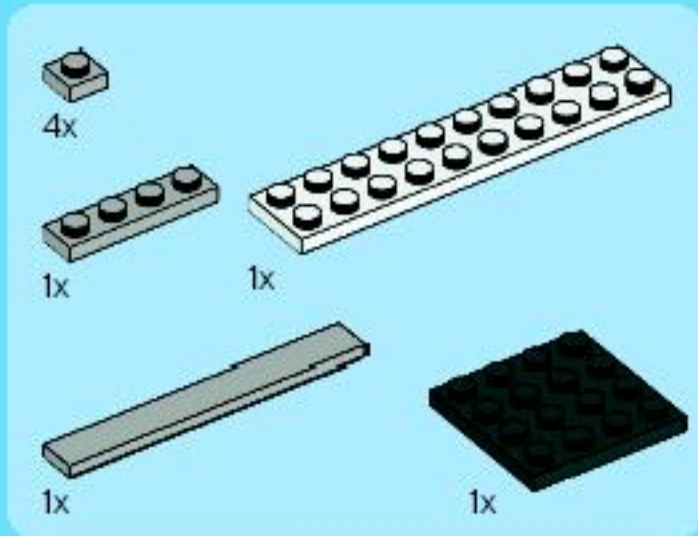

5

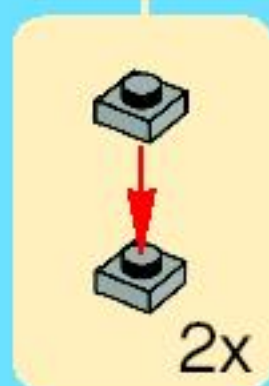
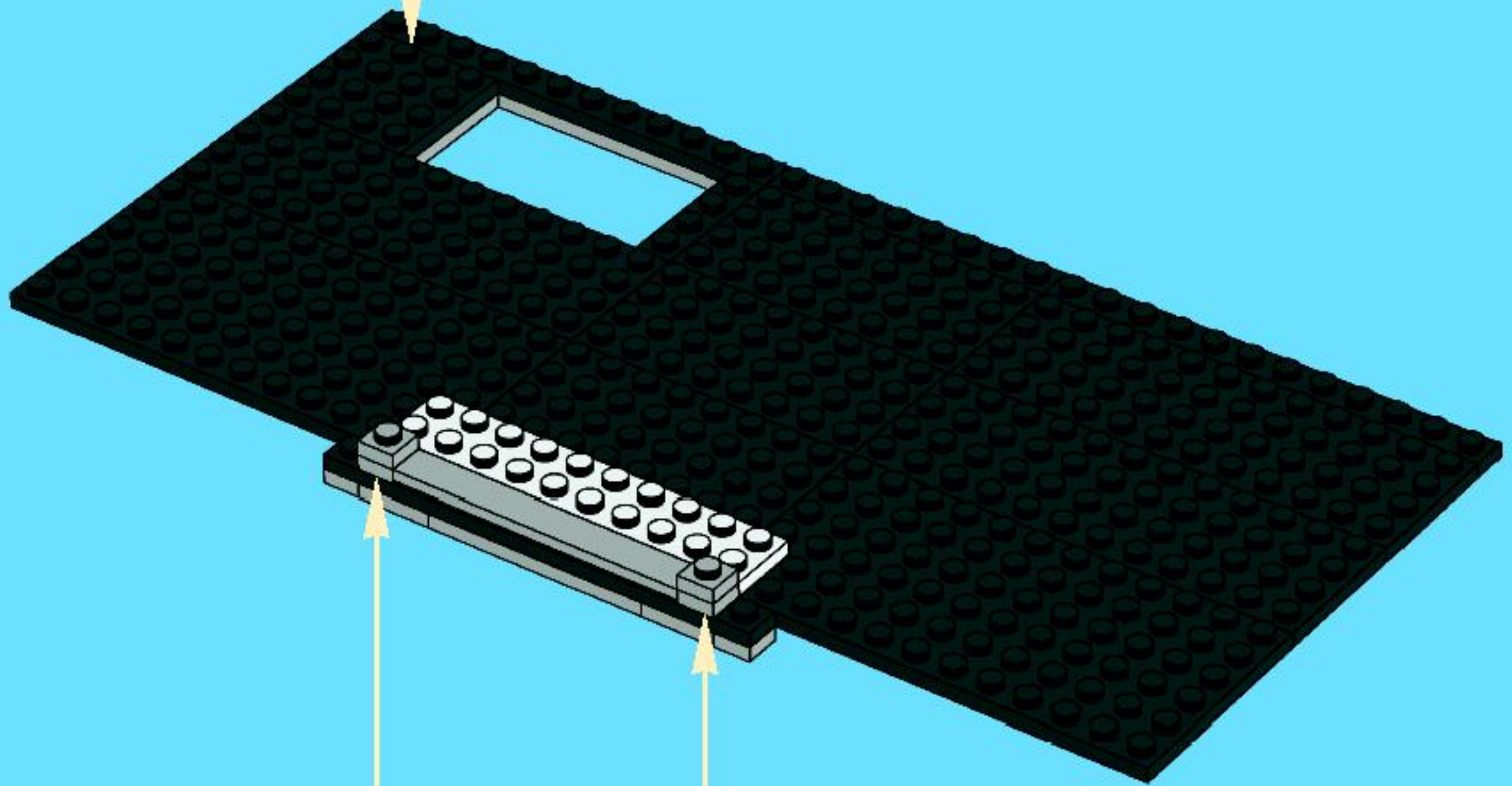
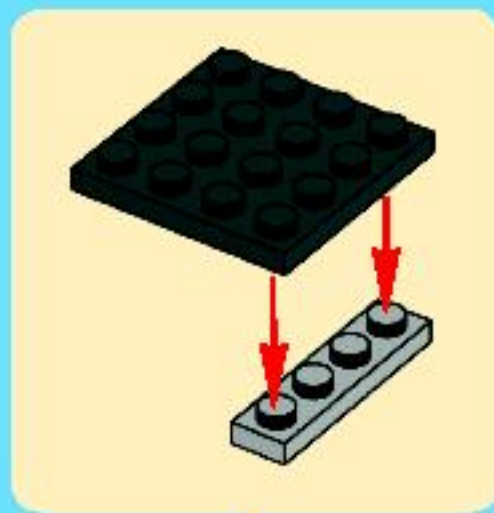

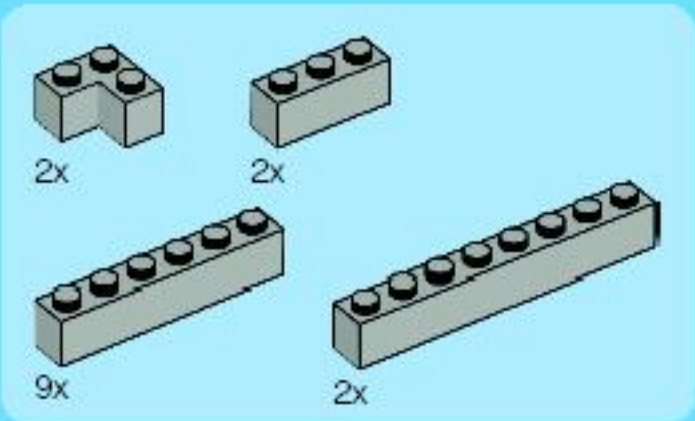

6

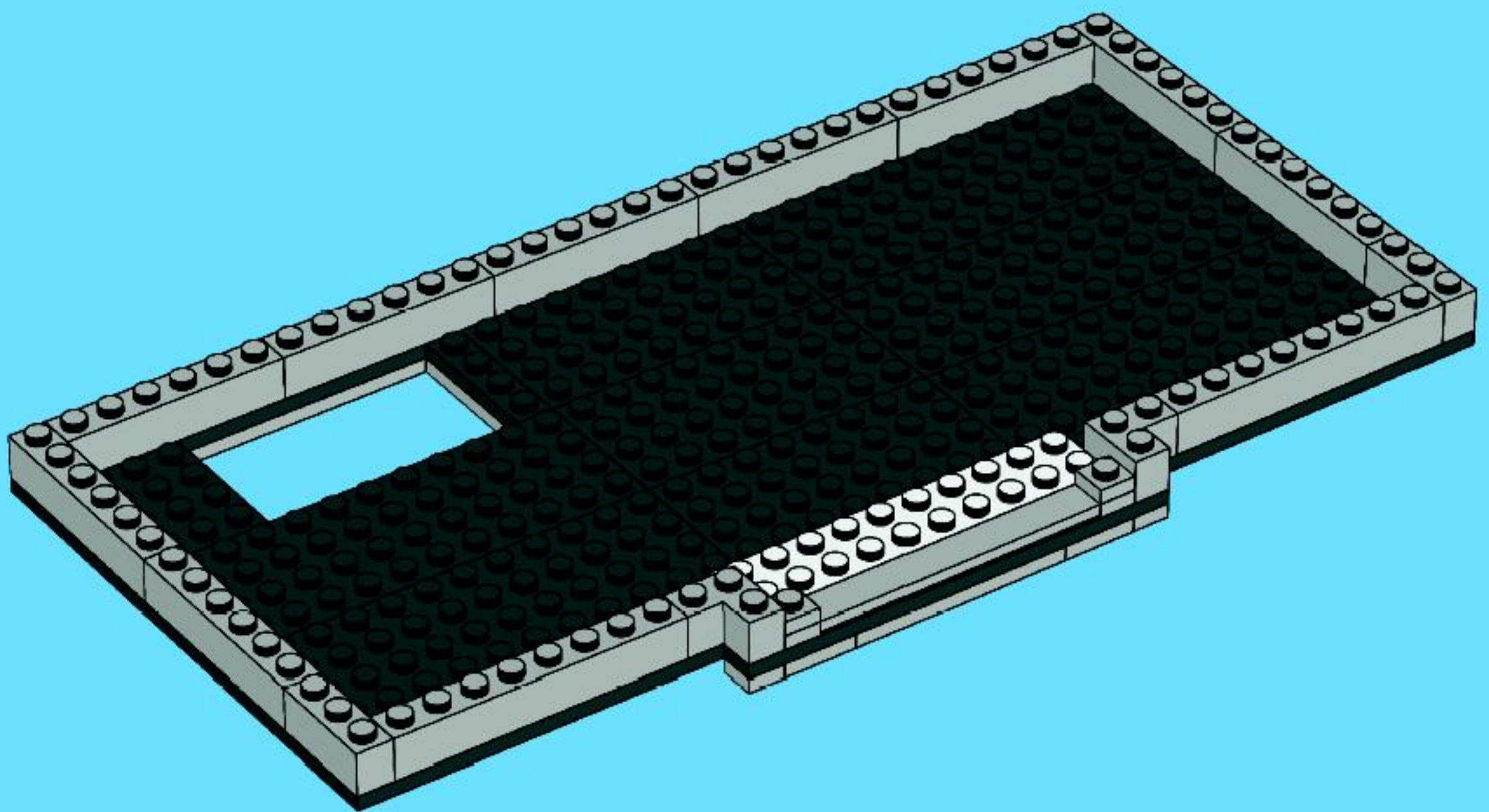

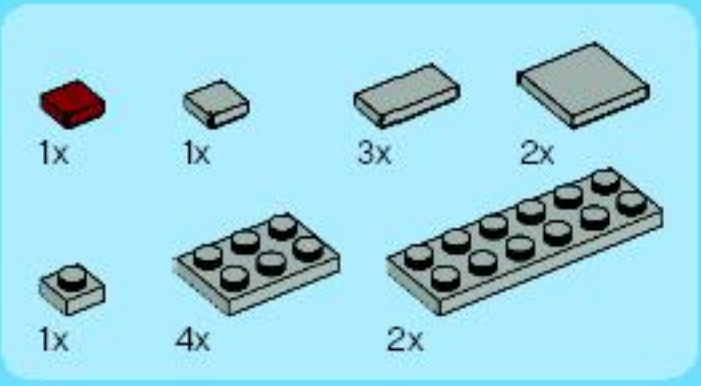

7

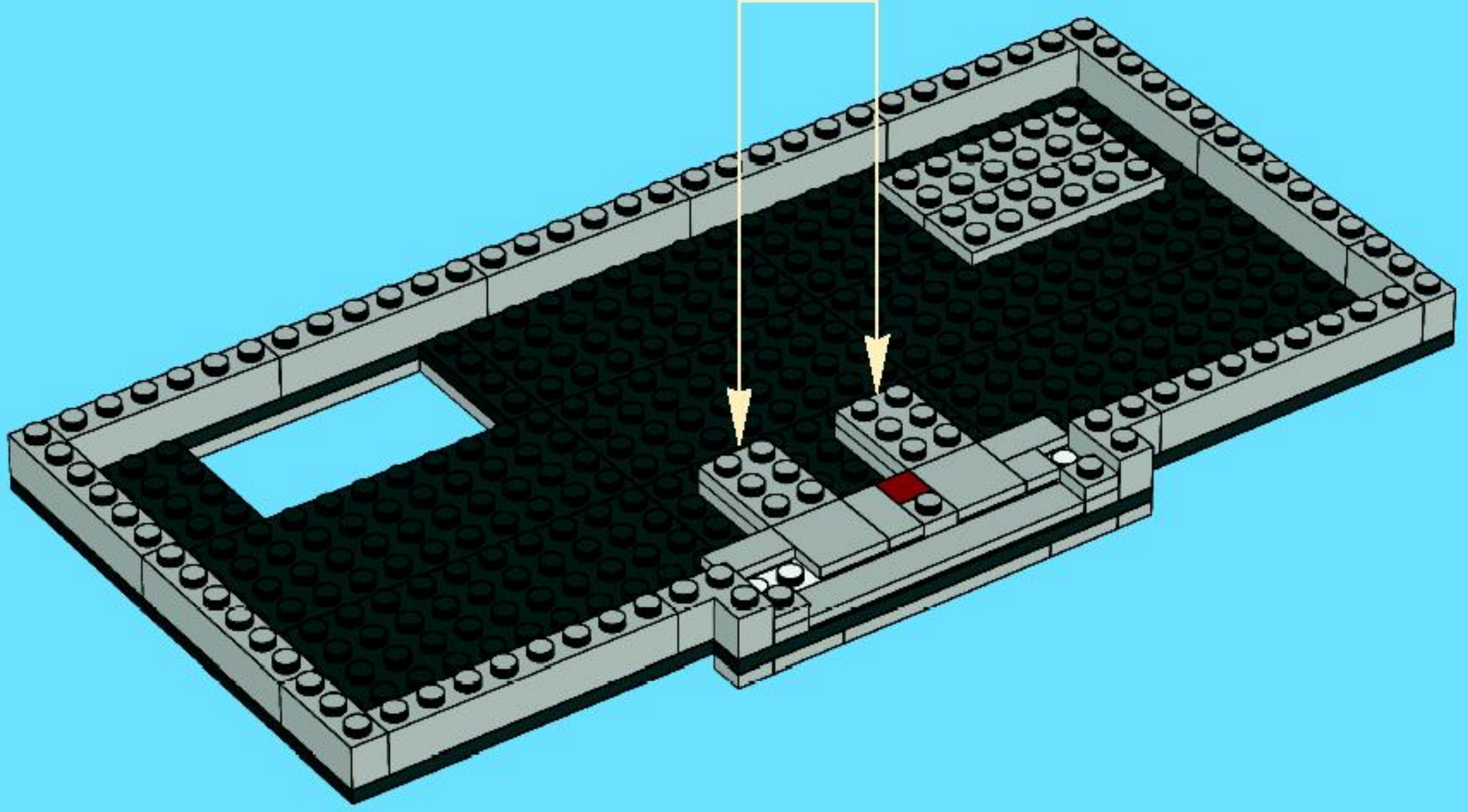
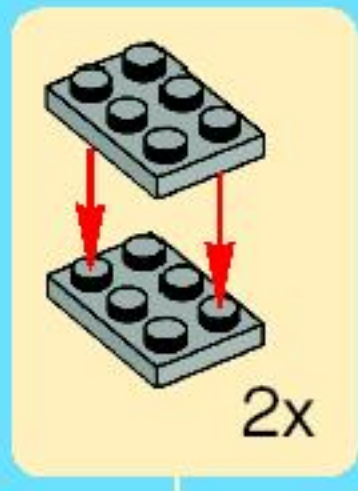

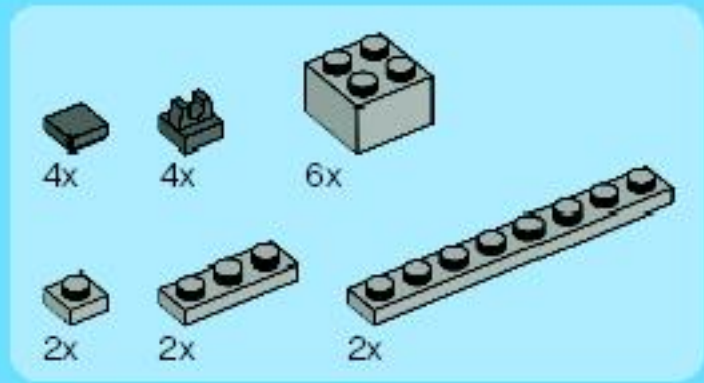

8

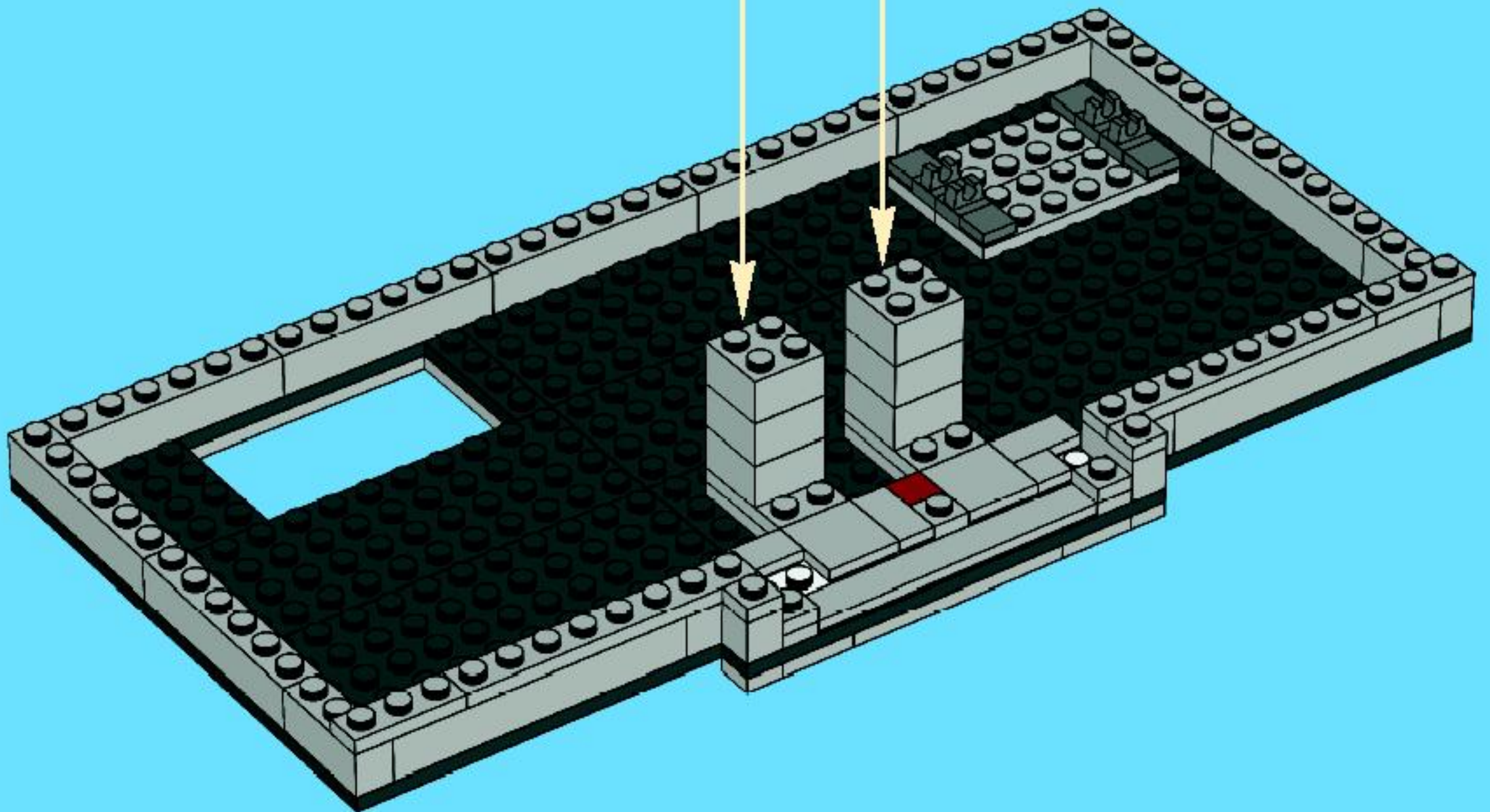
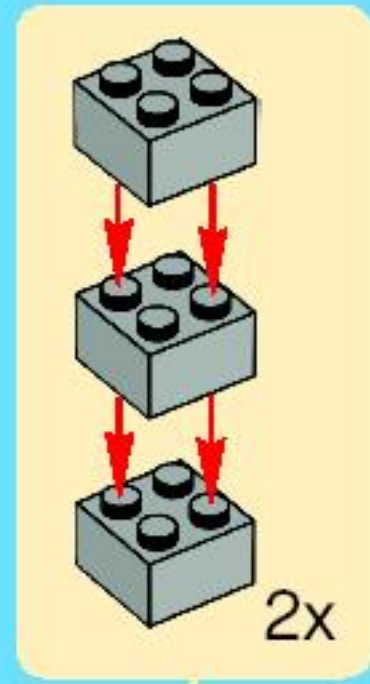

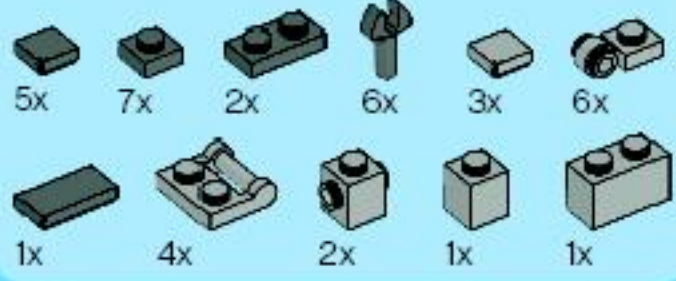
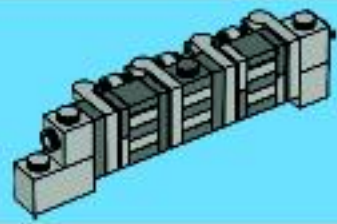

9

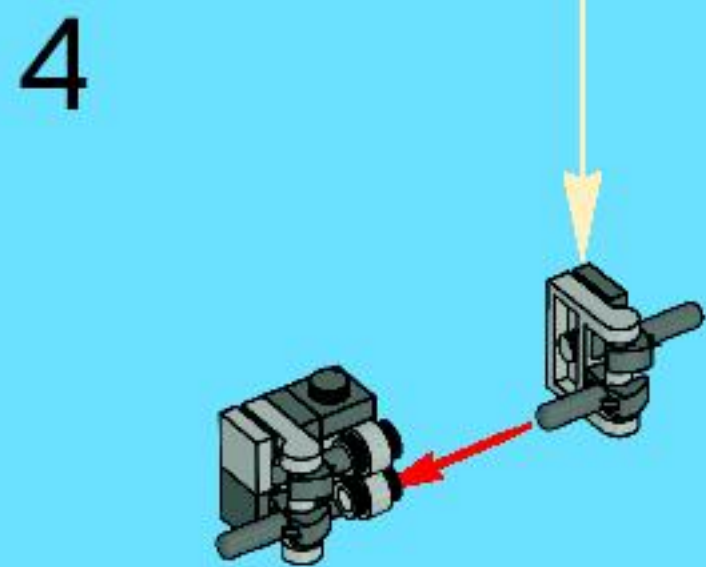
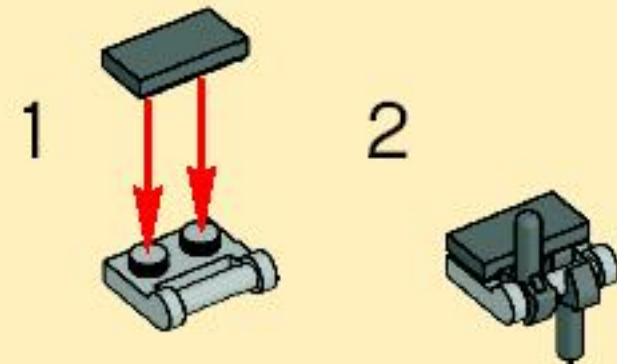
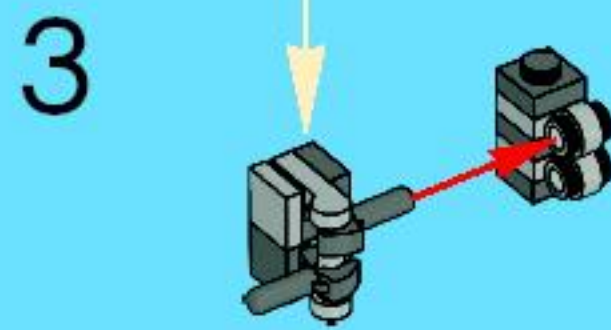
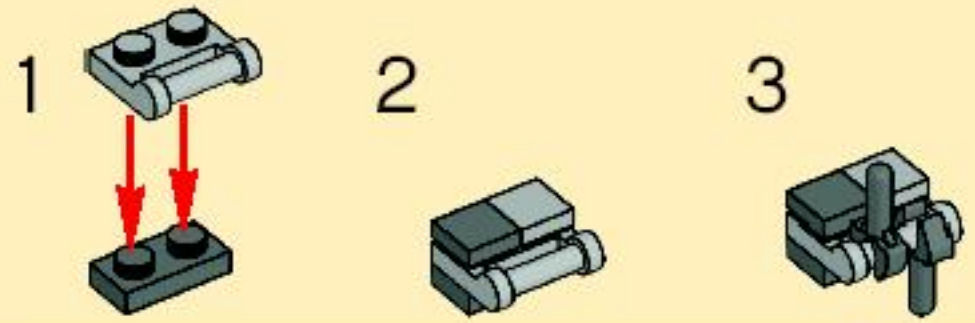
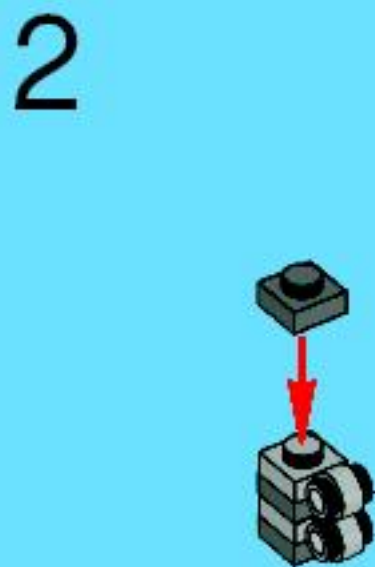
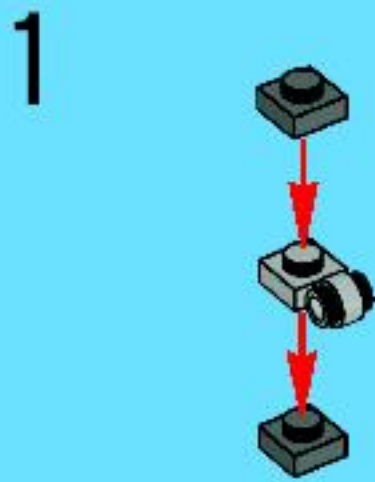

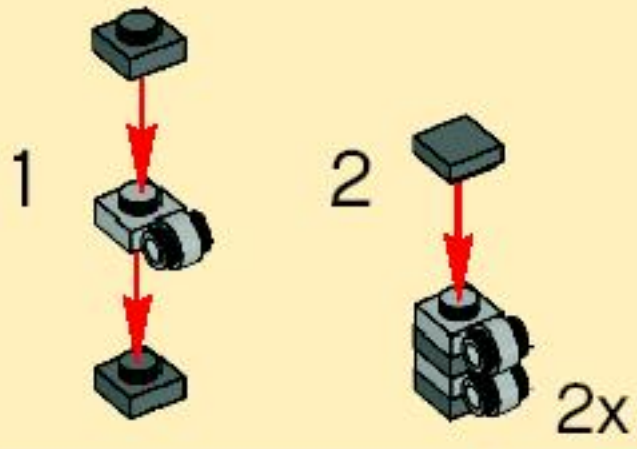

5

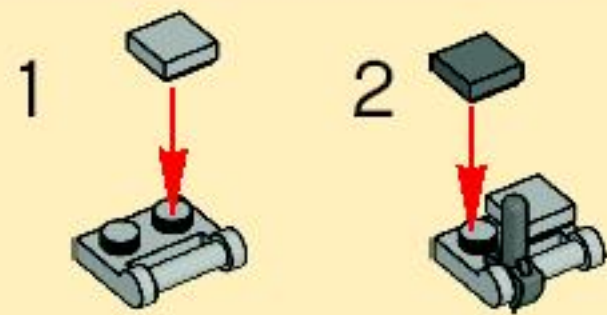

6

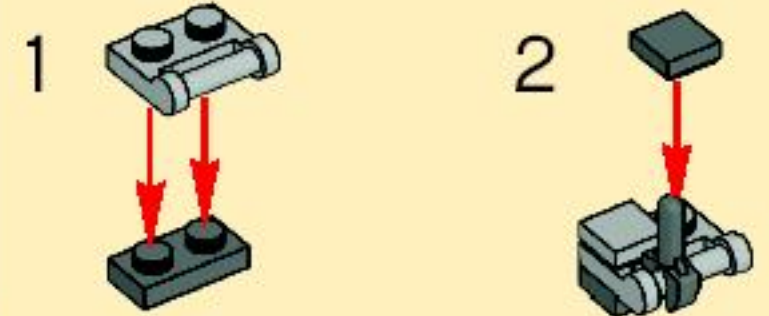

7

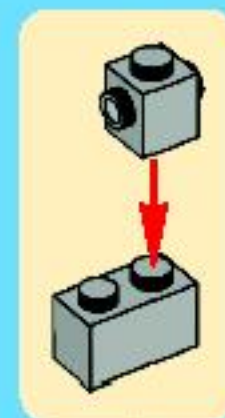
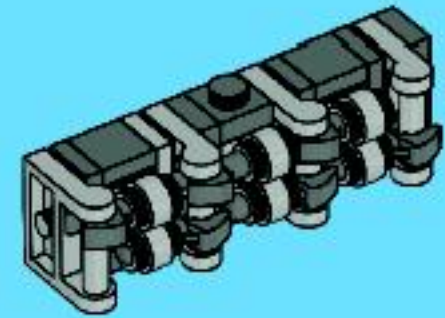

8

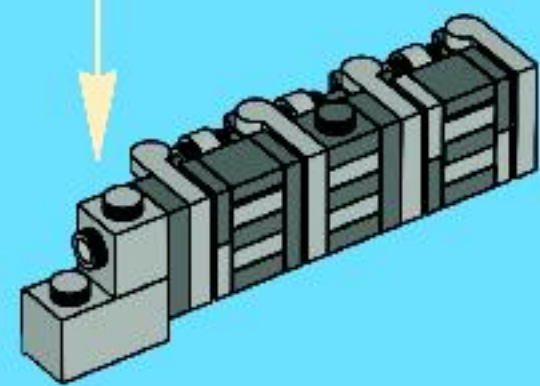

9

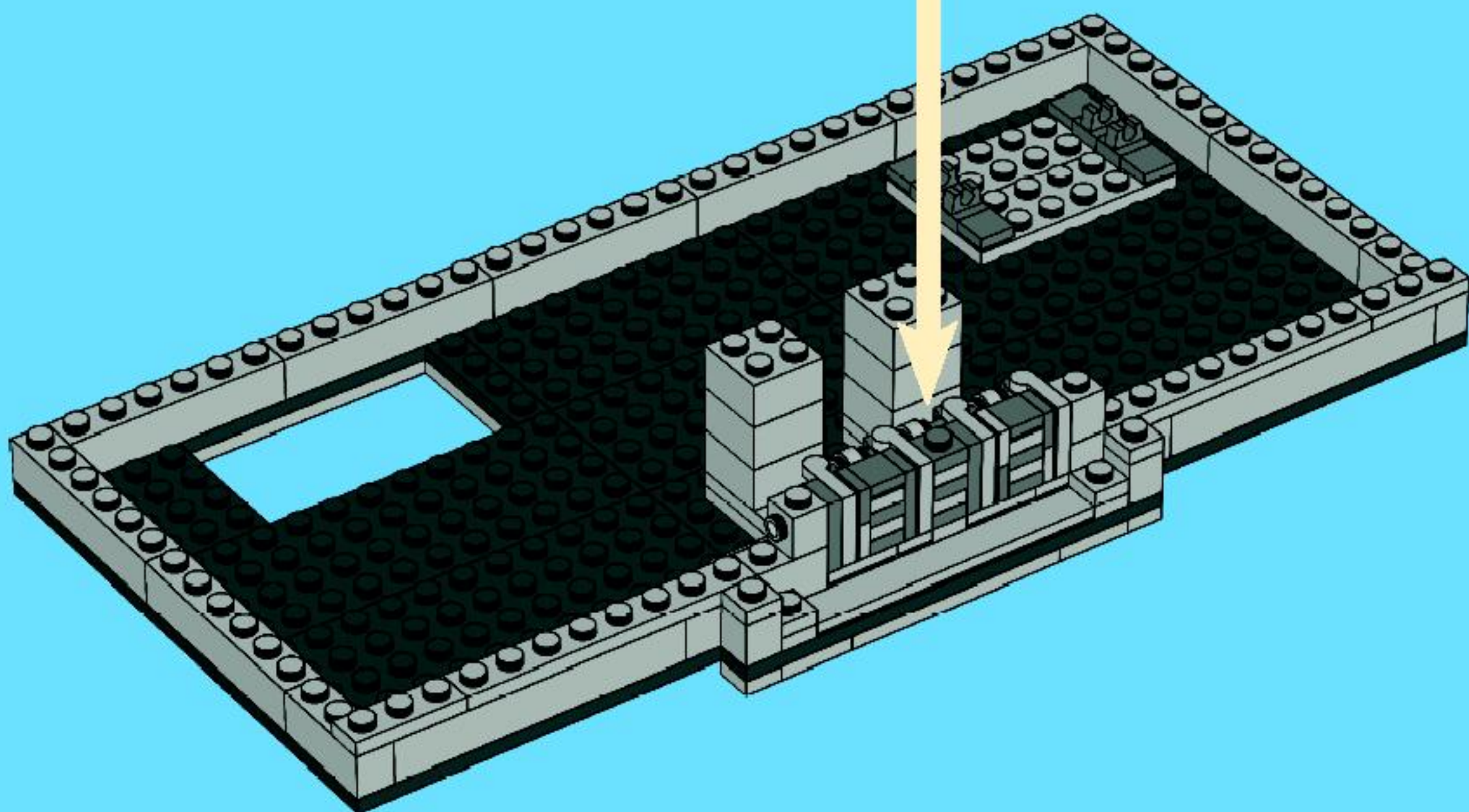
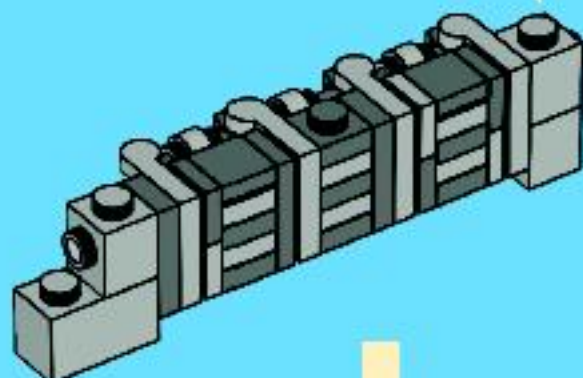
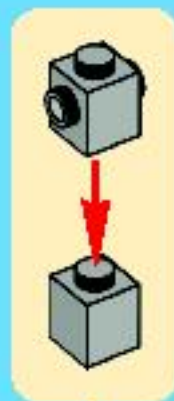

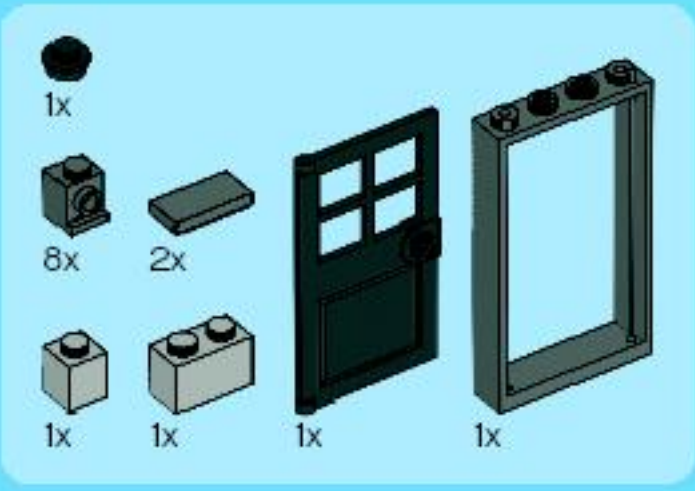

10

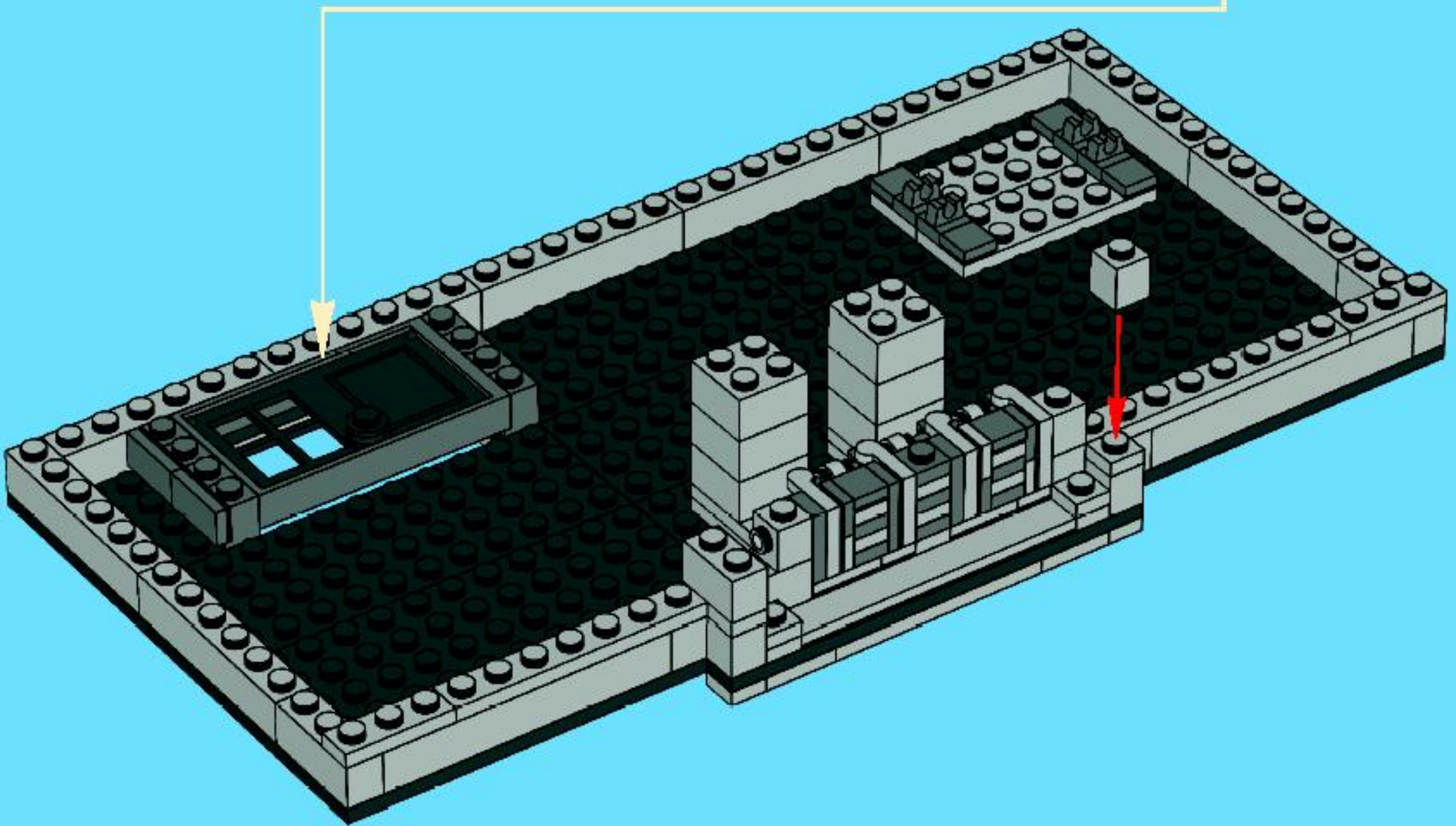
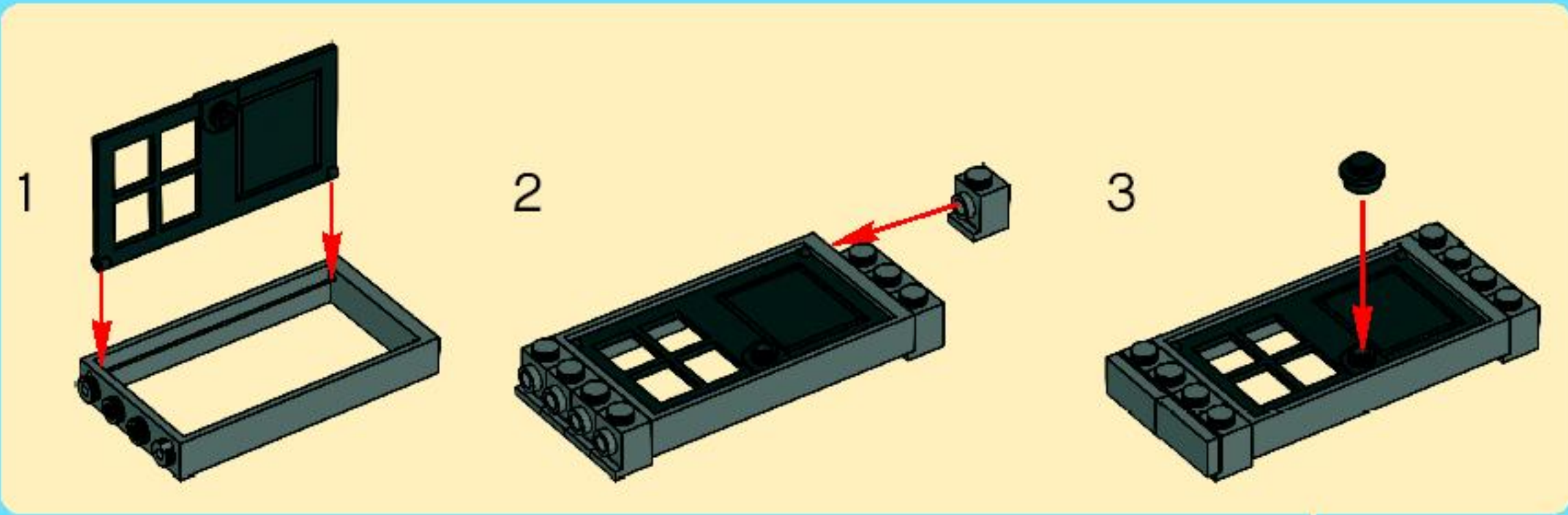

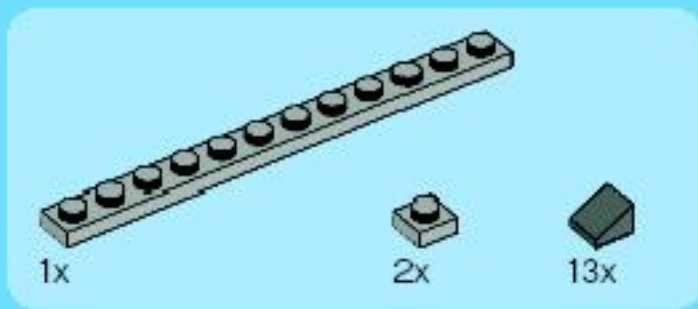

11

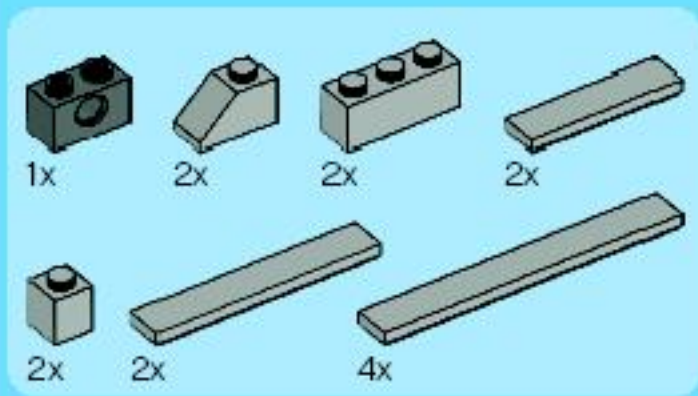
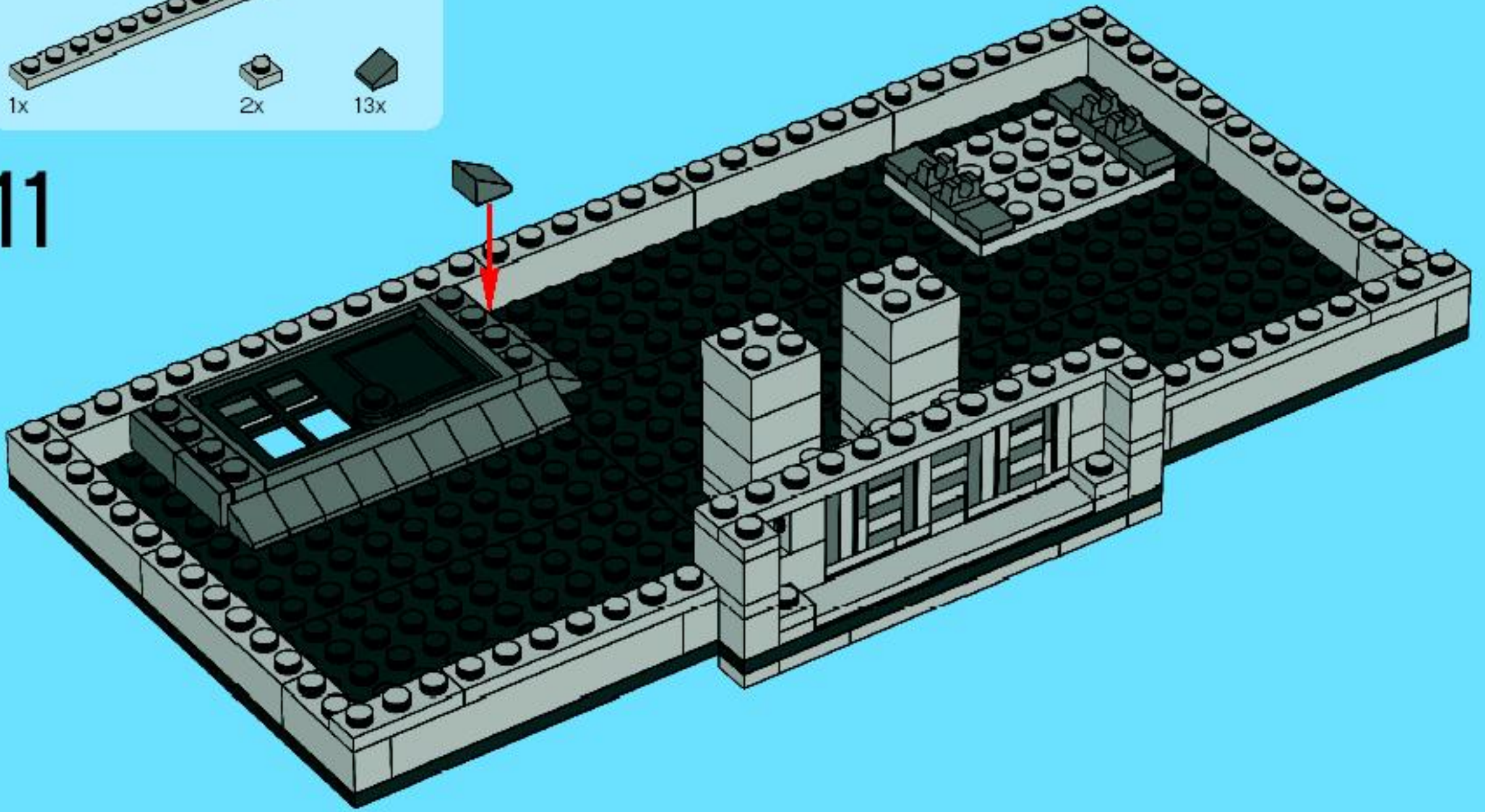

12

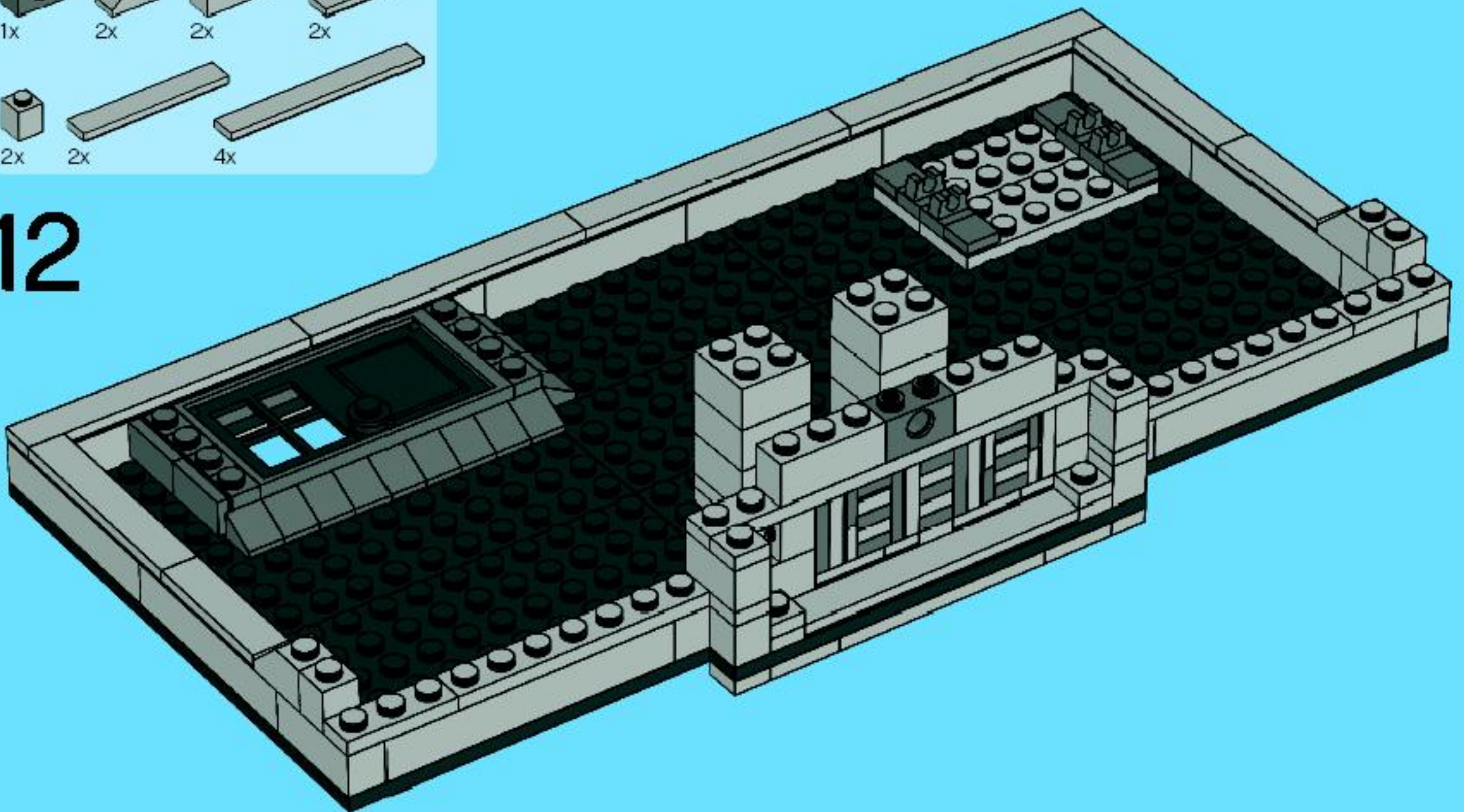

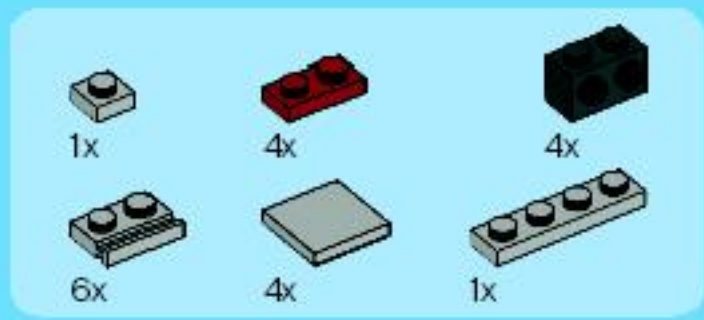

13

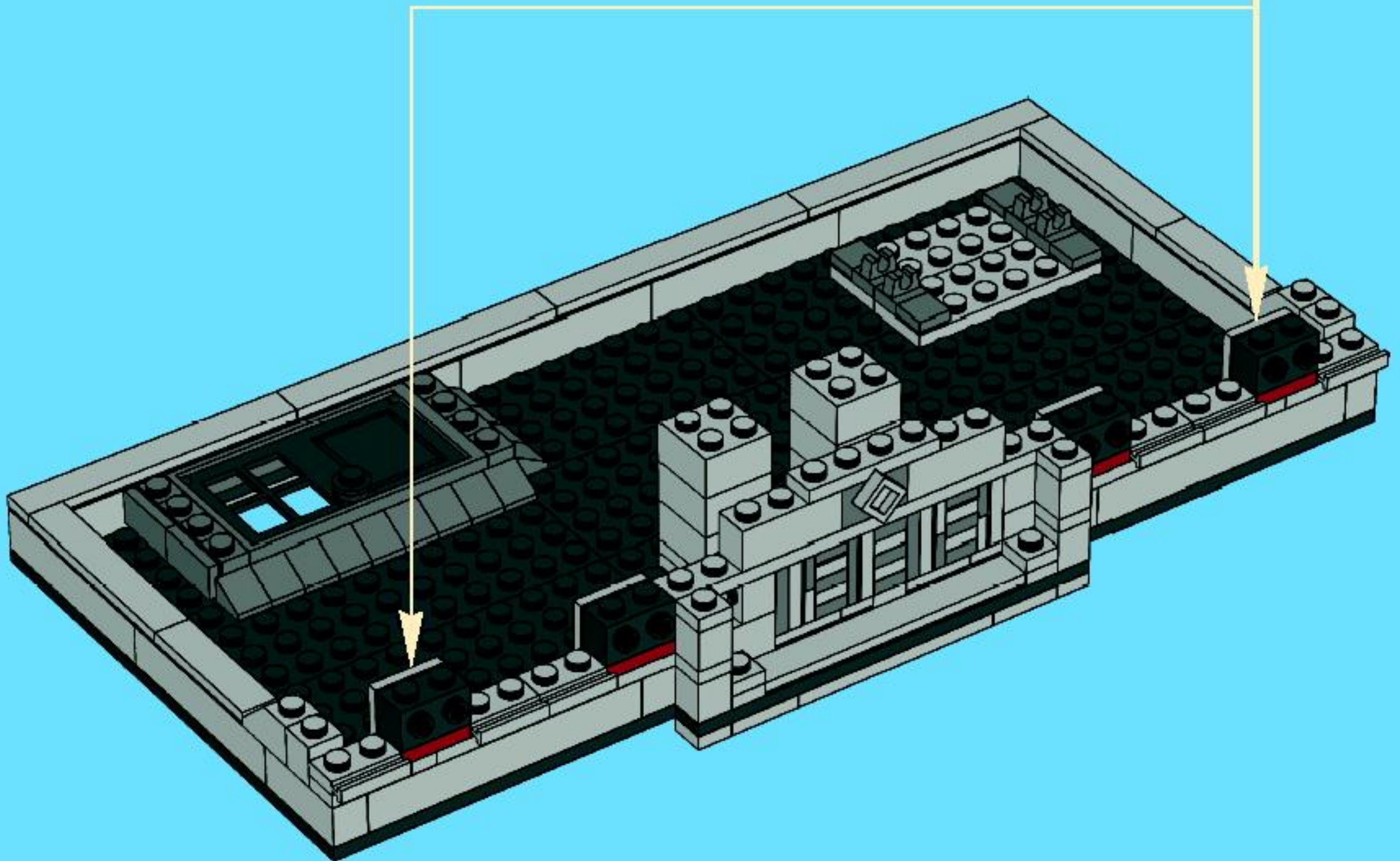
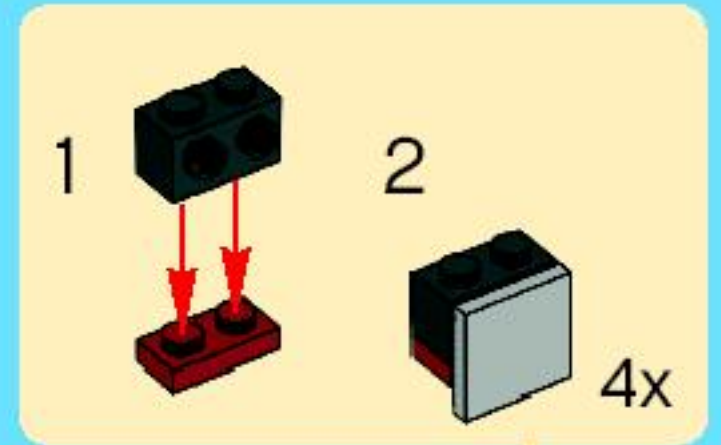

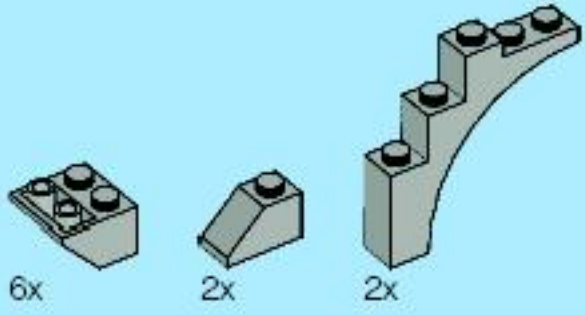

14

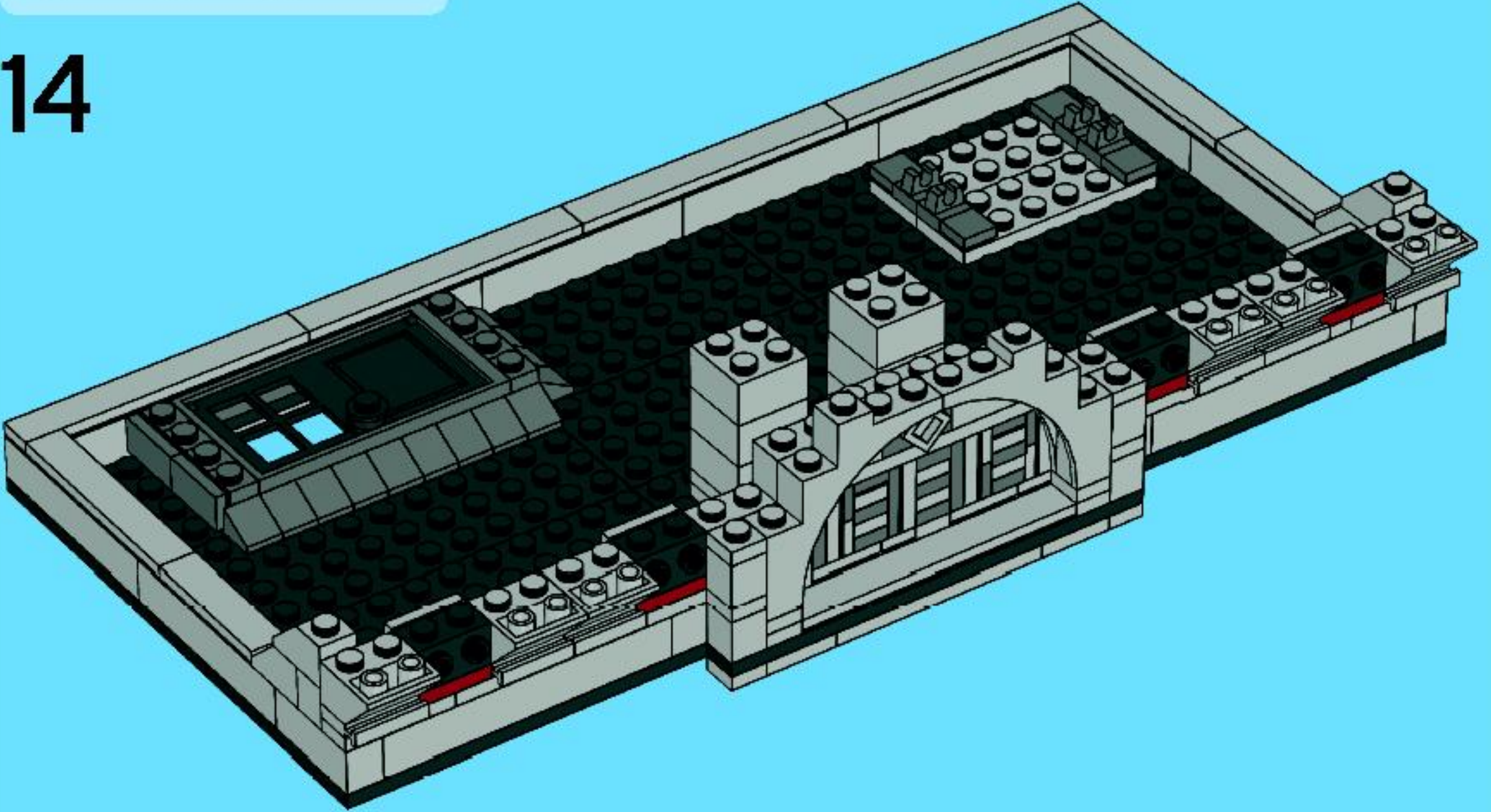

15

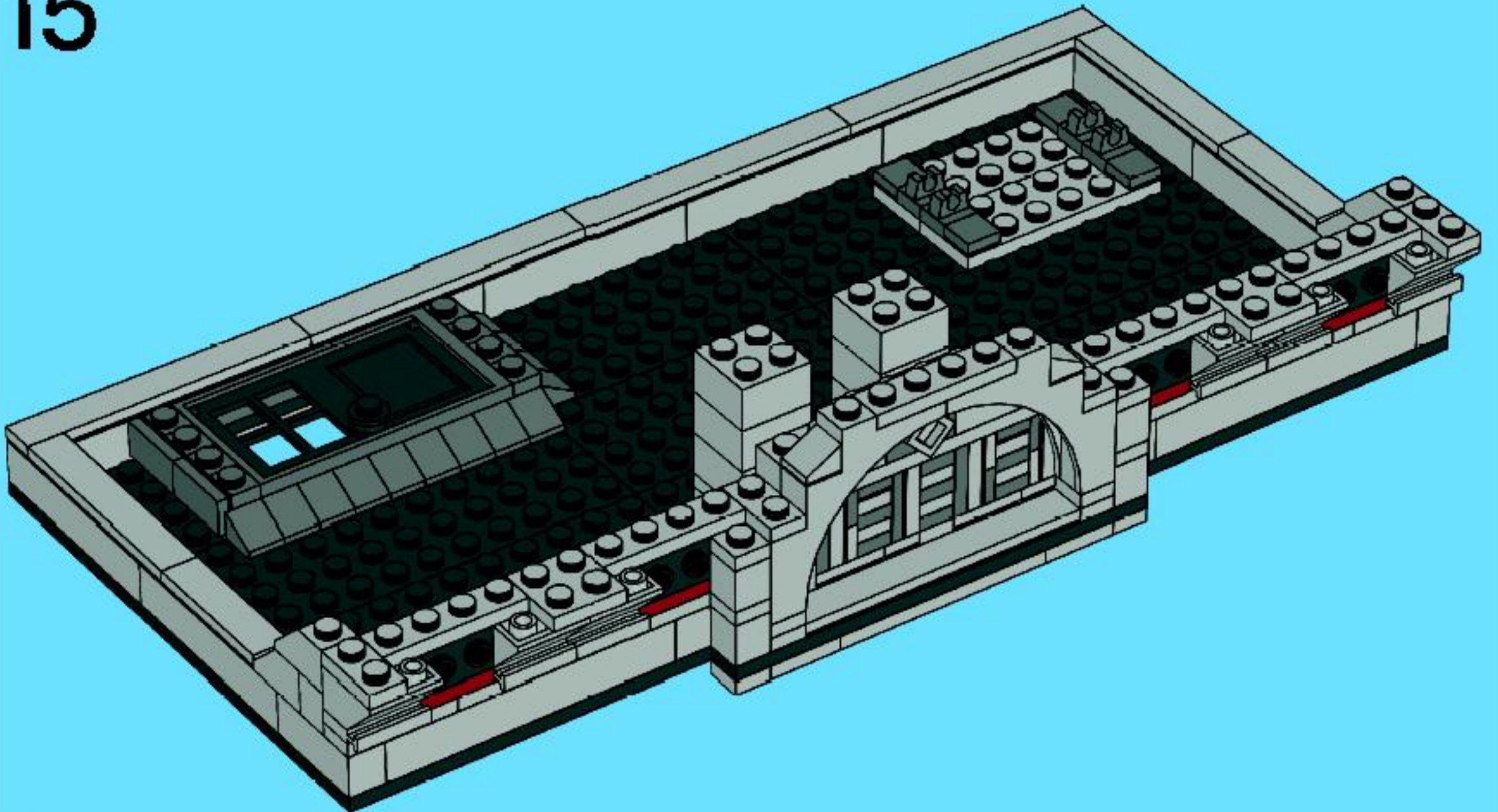



8x



4x



4x



8x



4x



4x

16

1

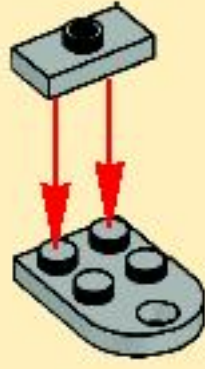

2



3

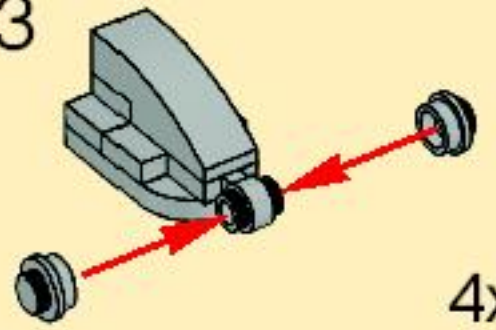

4x

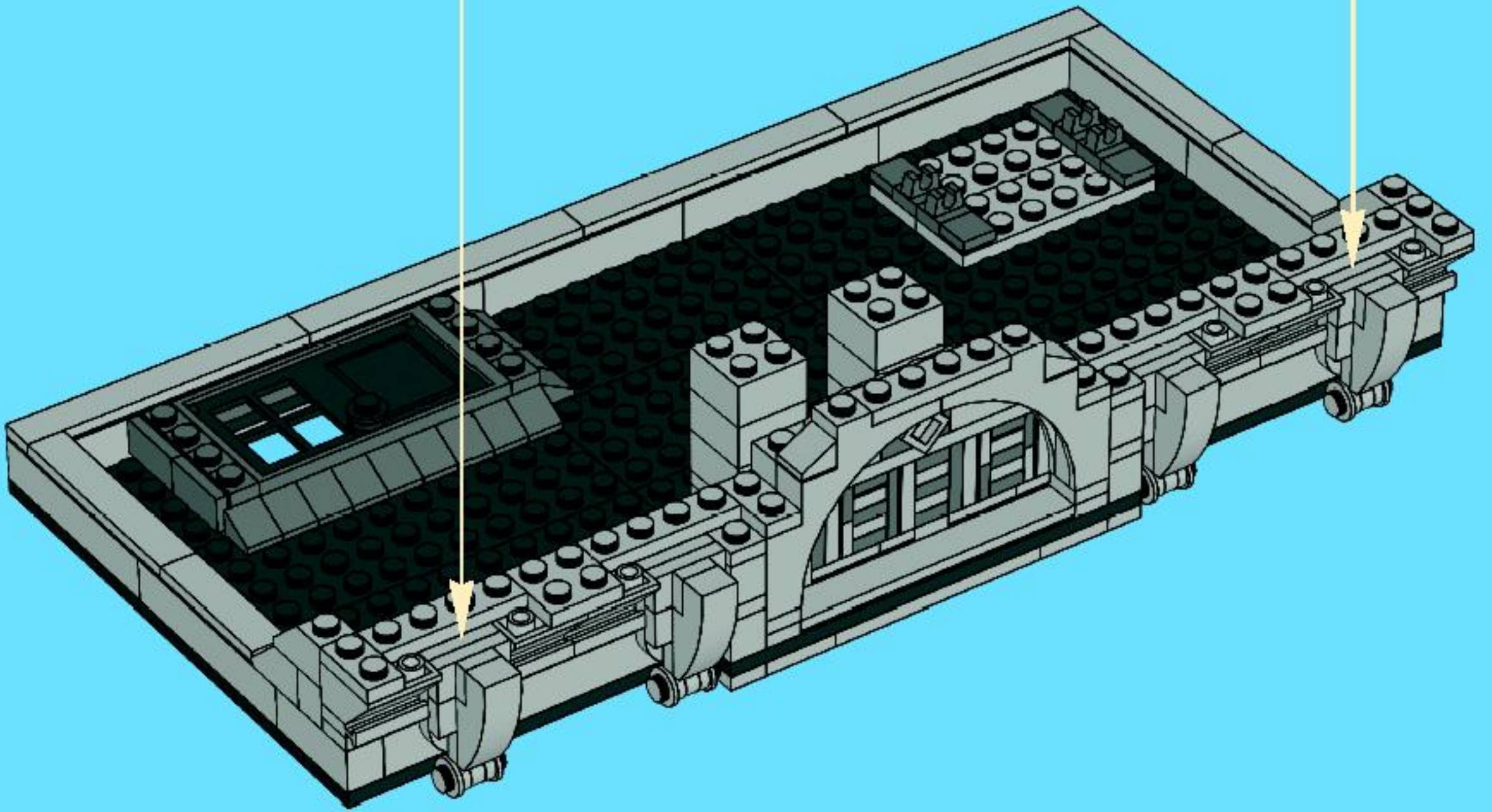



1x



8x



3x

17

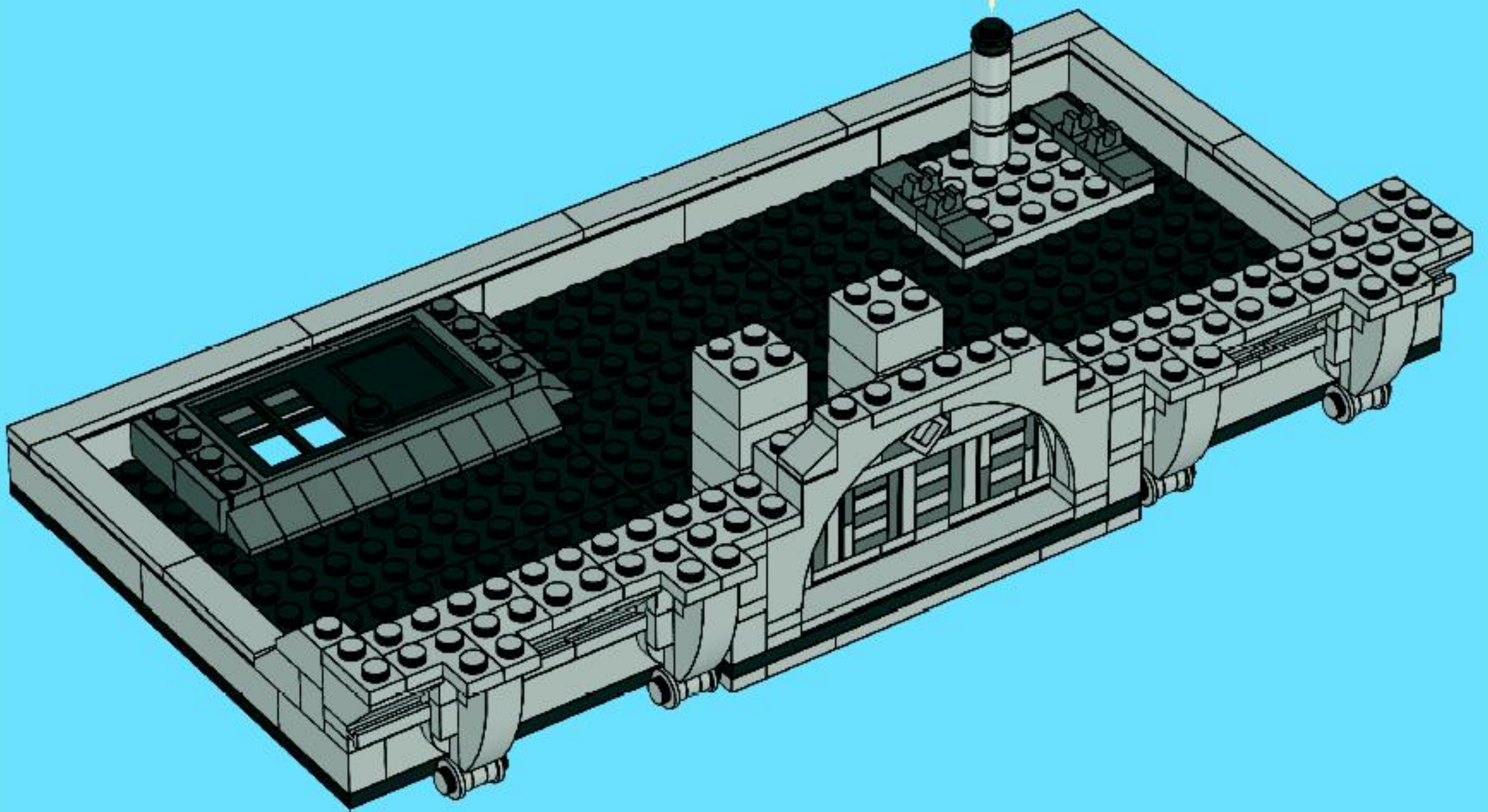
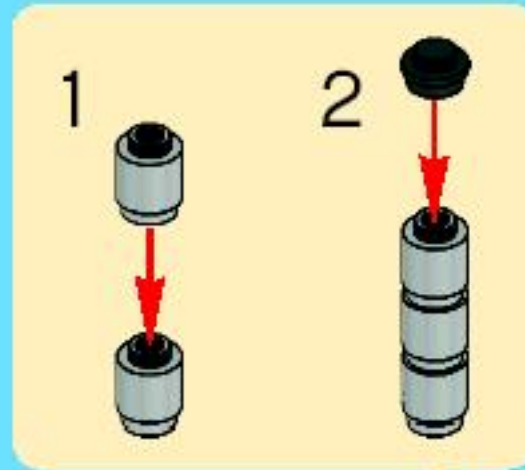

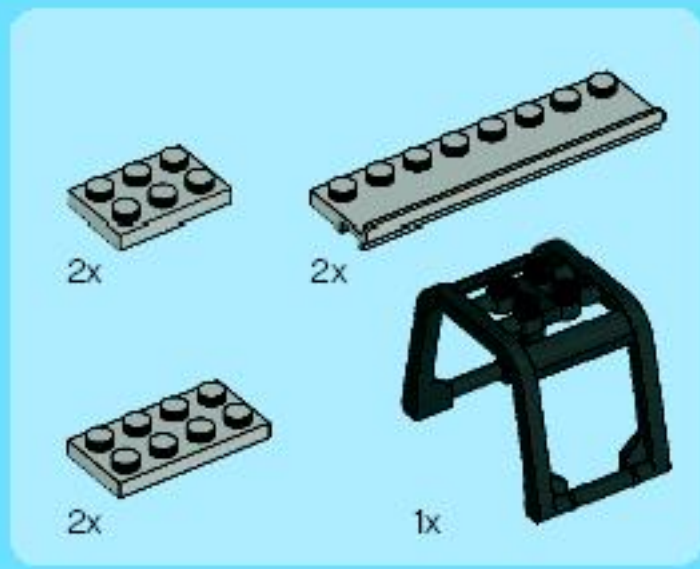

18

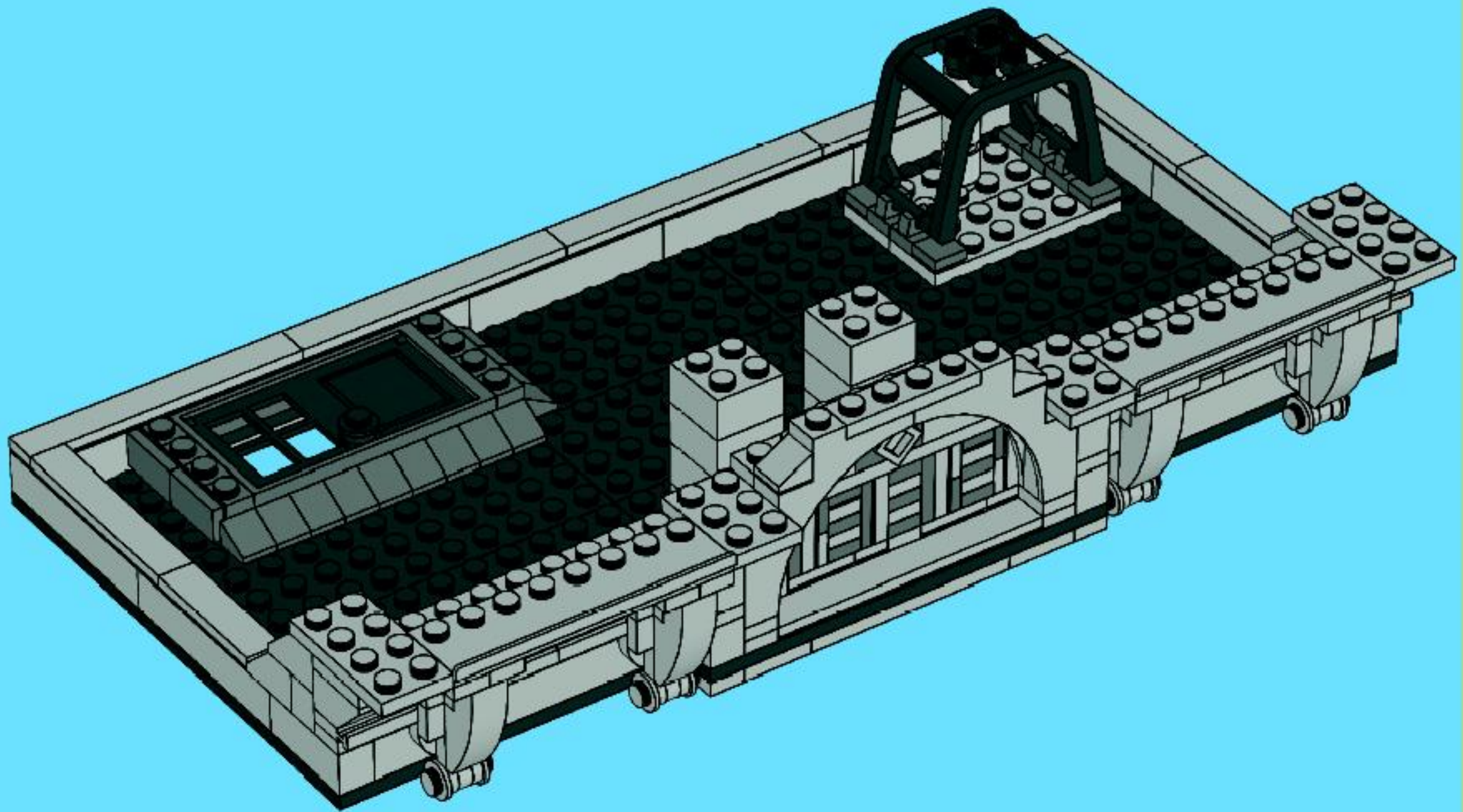

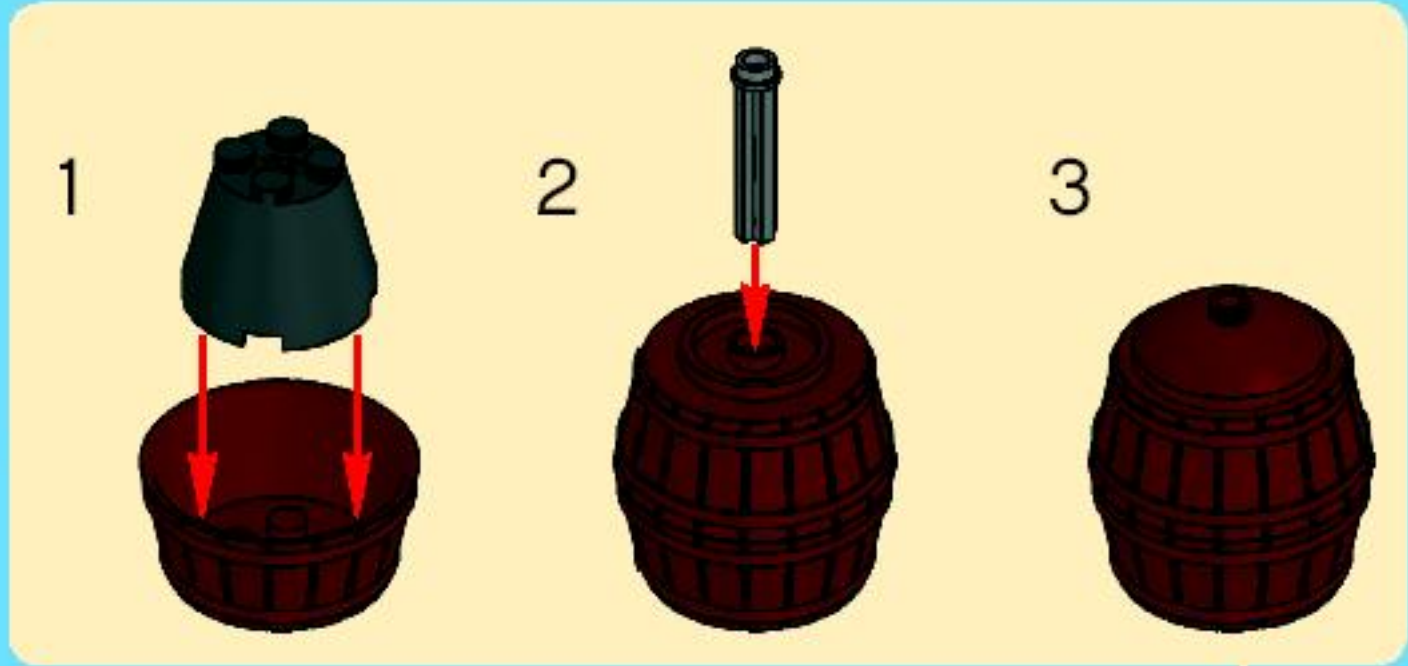
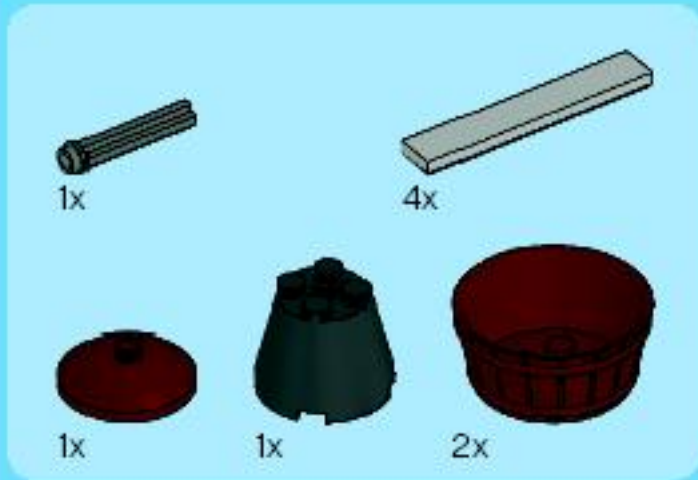

19

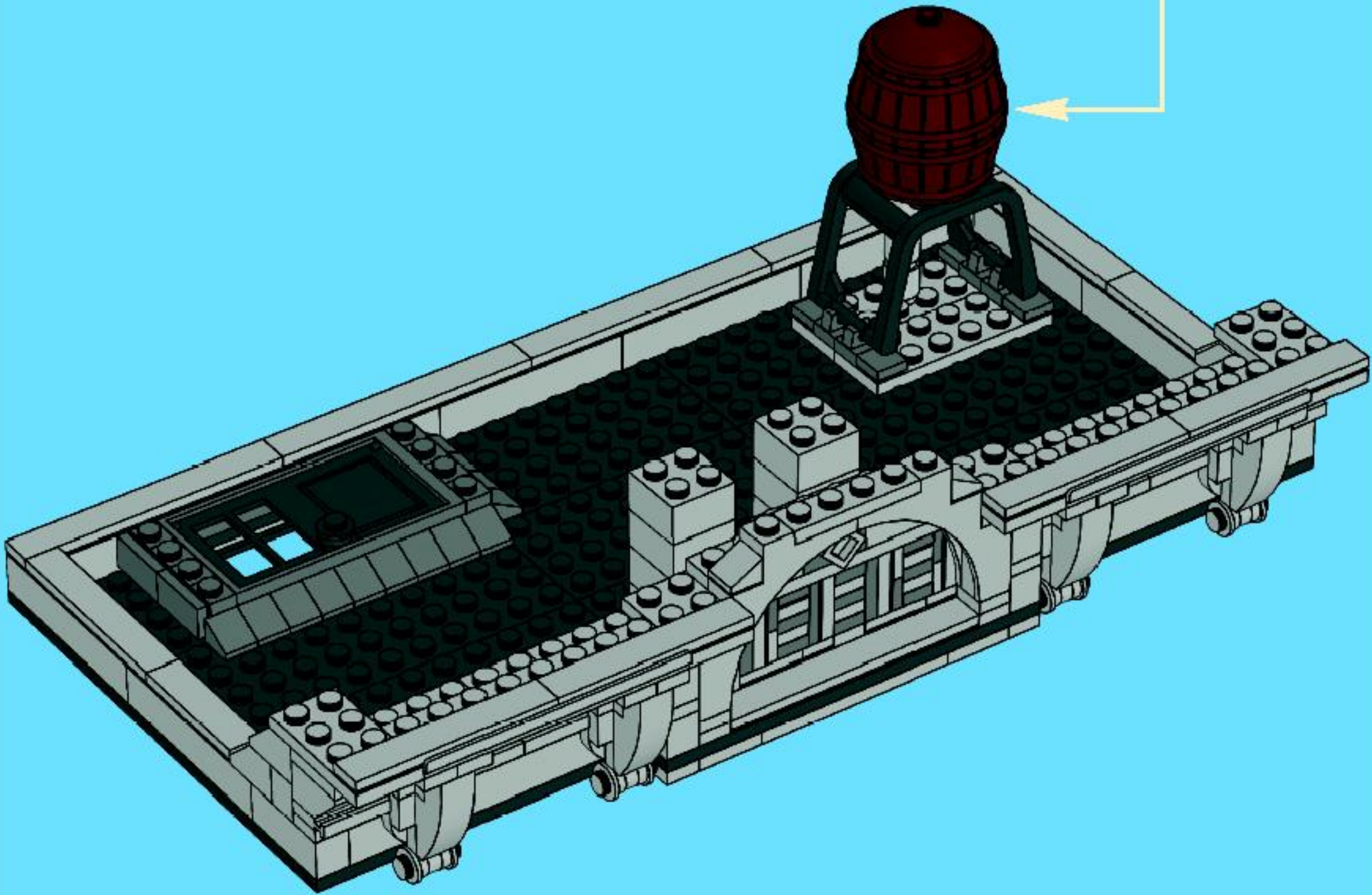

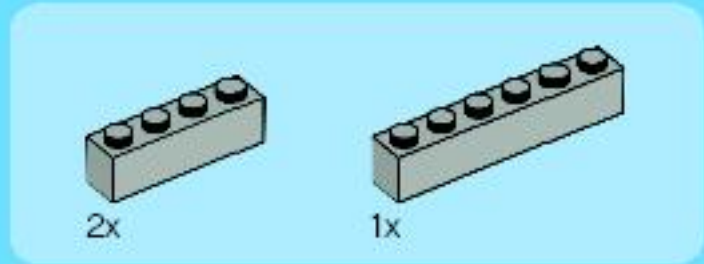

1

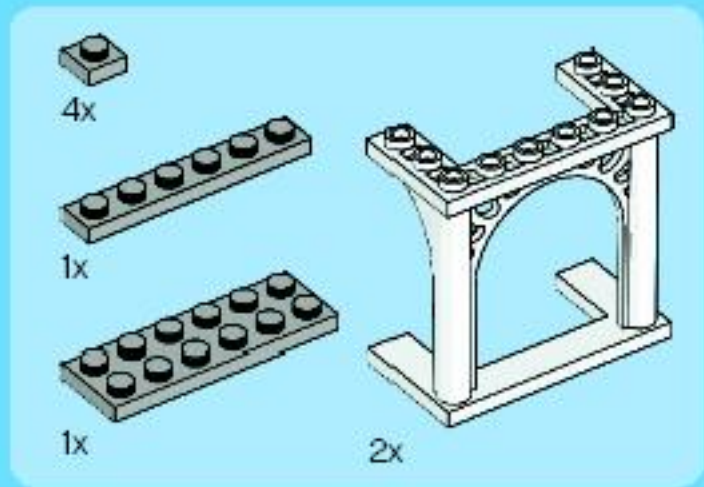
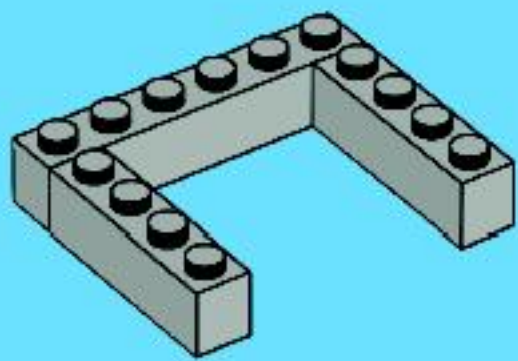

2

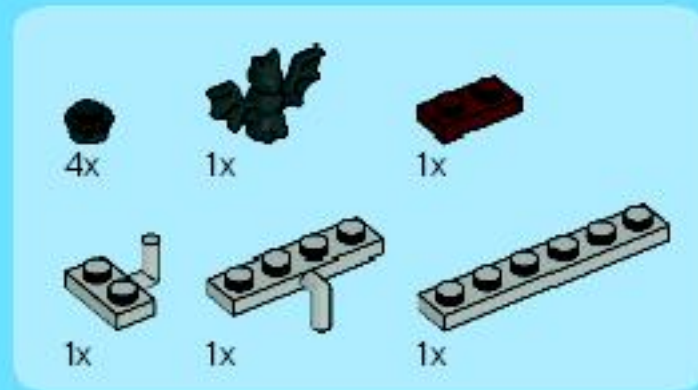
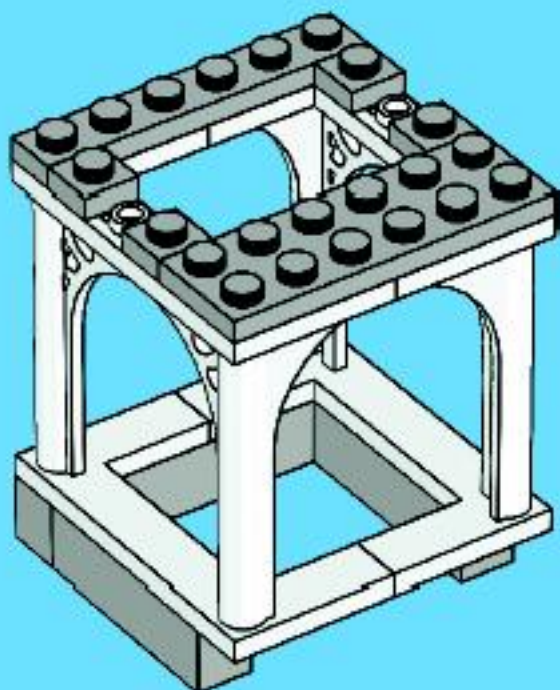

3

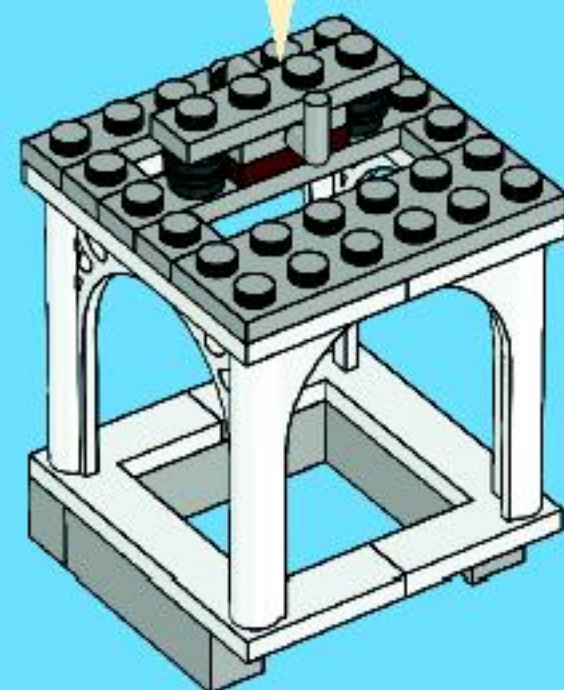
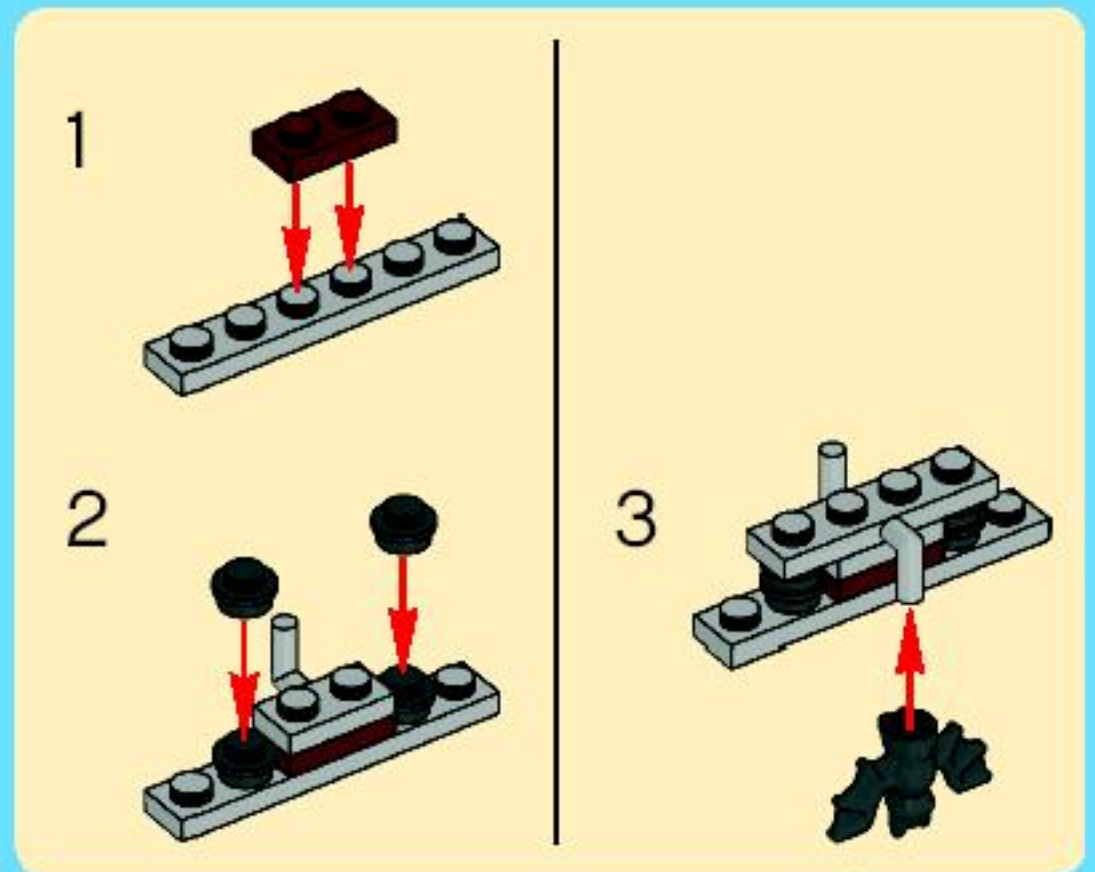

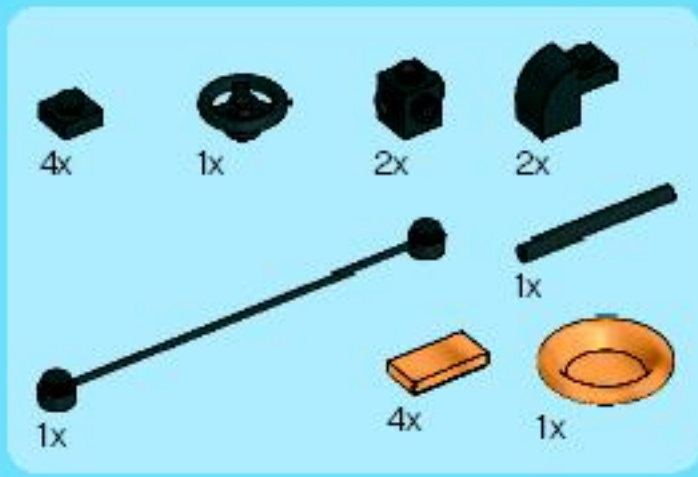

4

1



2



3



4

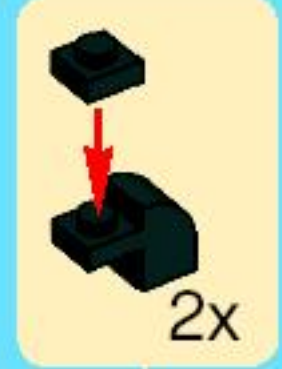

5



6



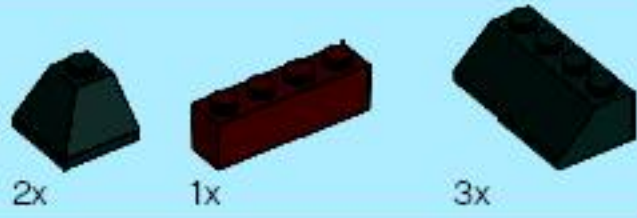
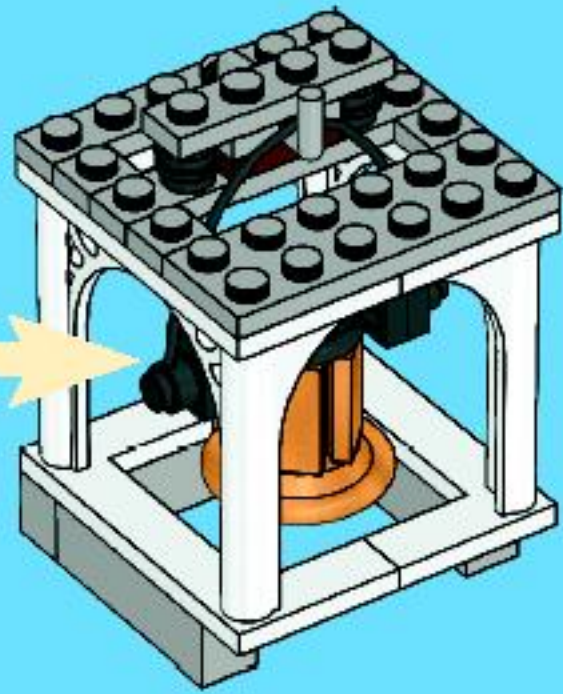

5

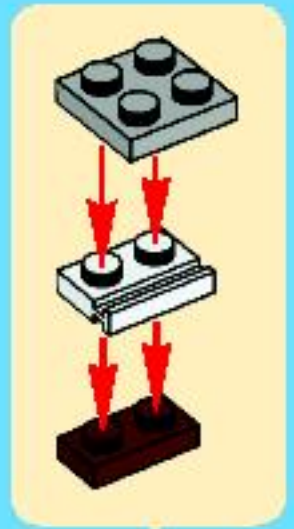
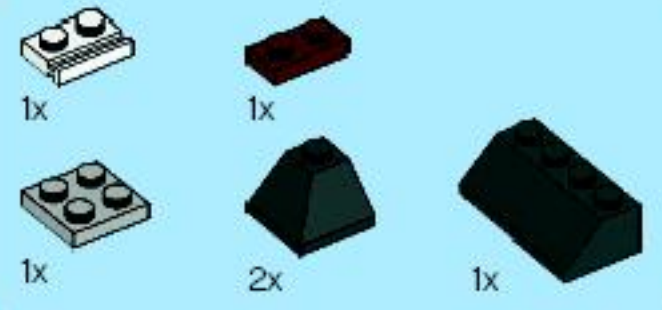
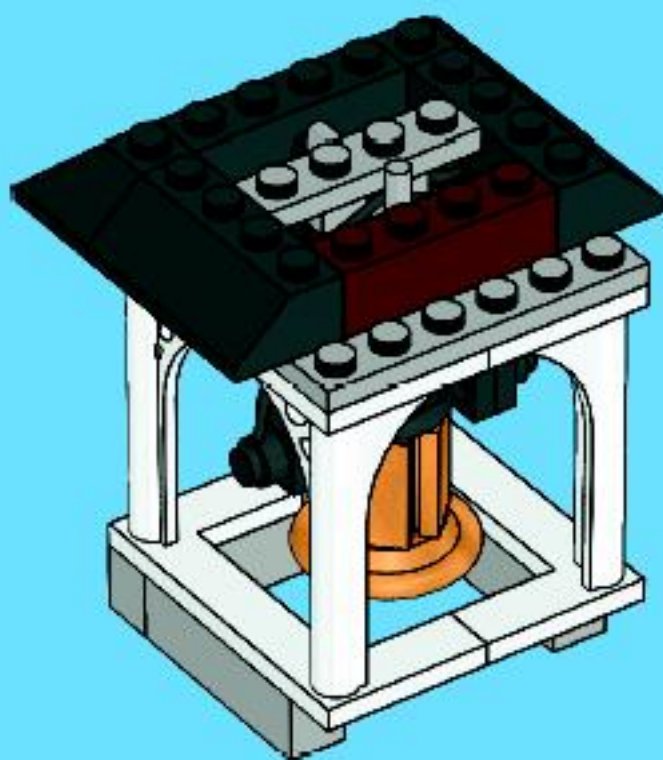

6

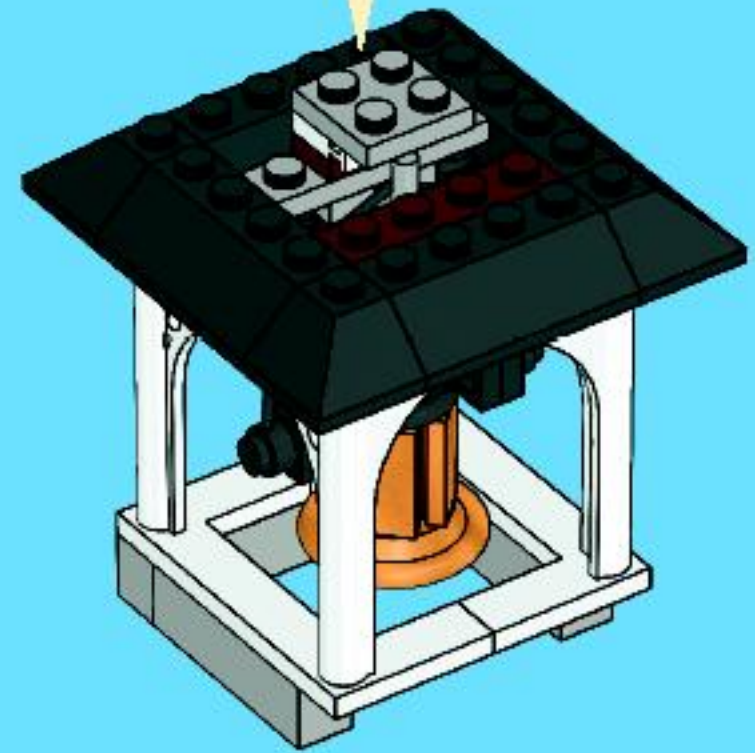

7

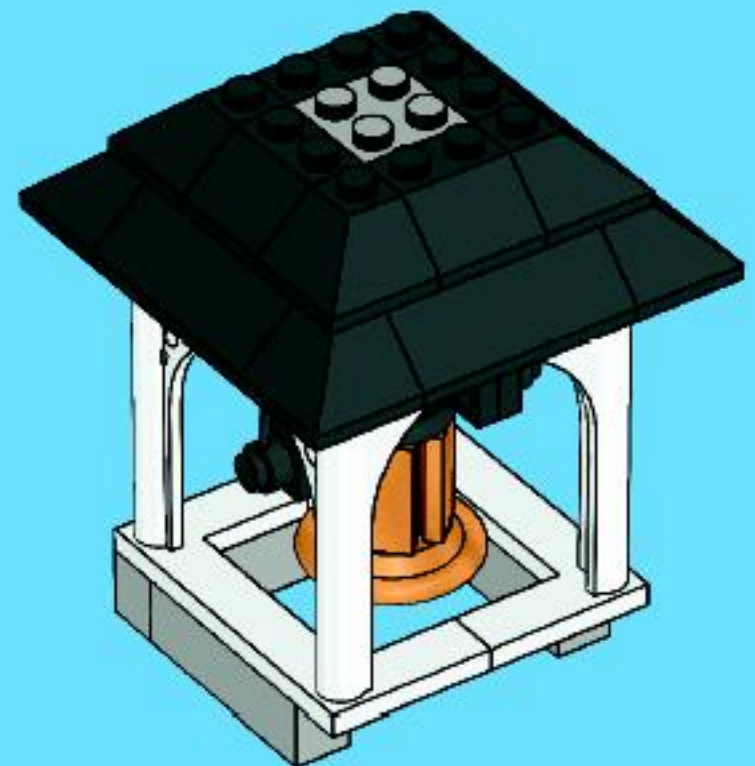



4x



1x

8

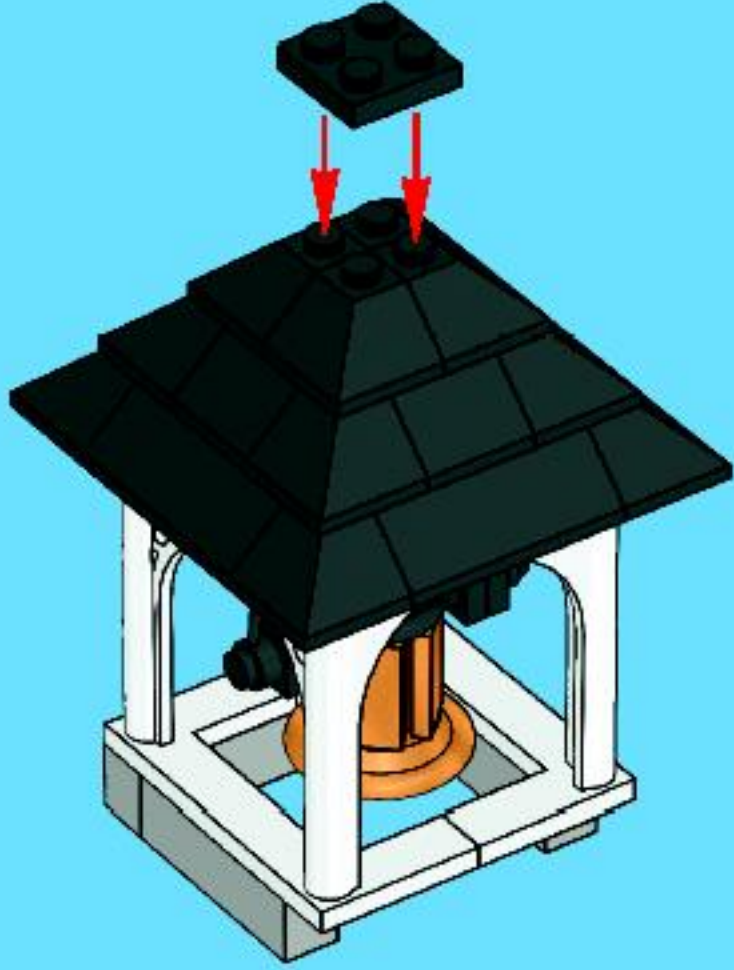

1x



1x



1x

9

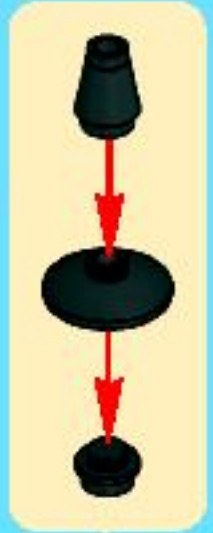

20

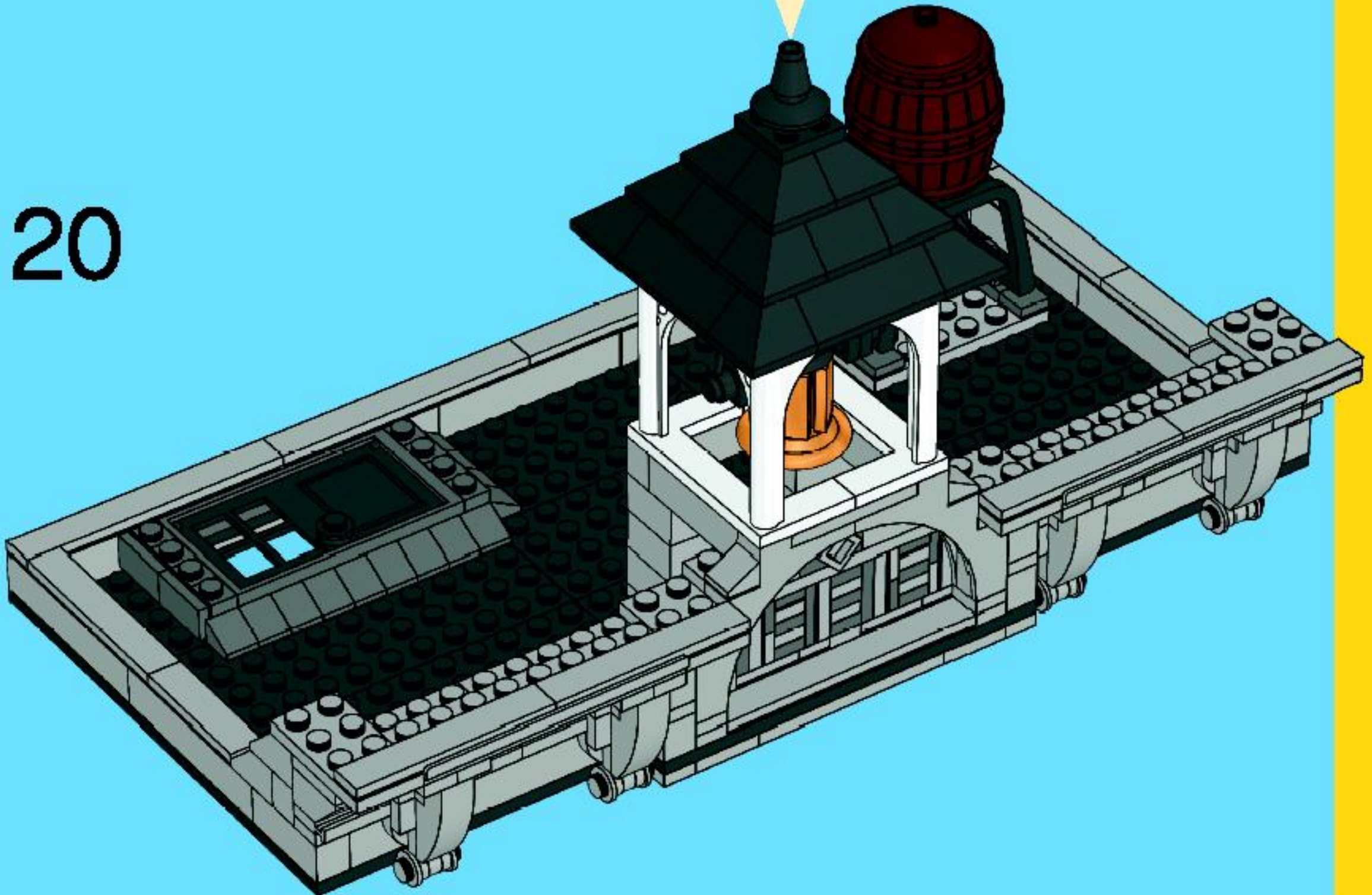

21



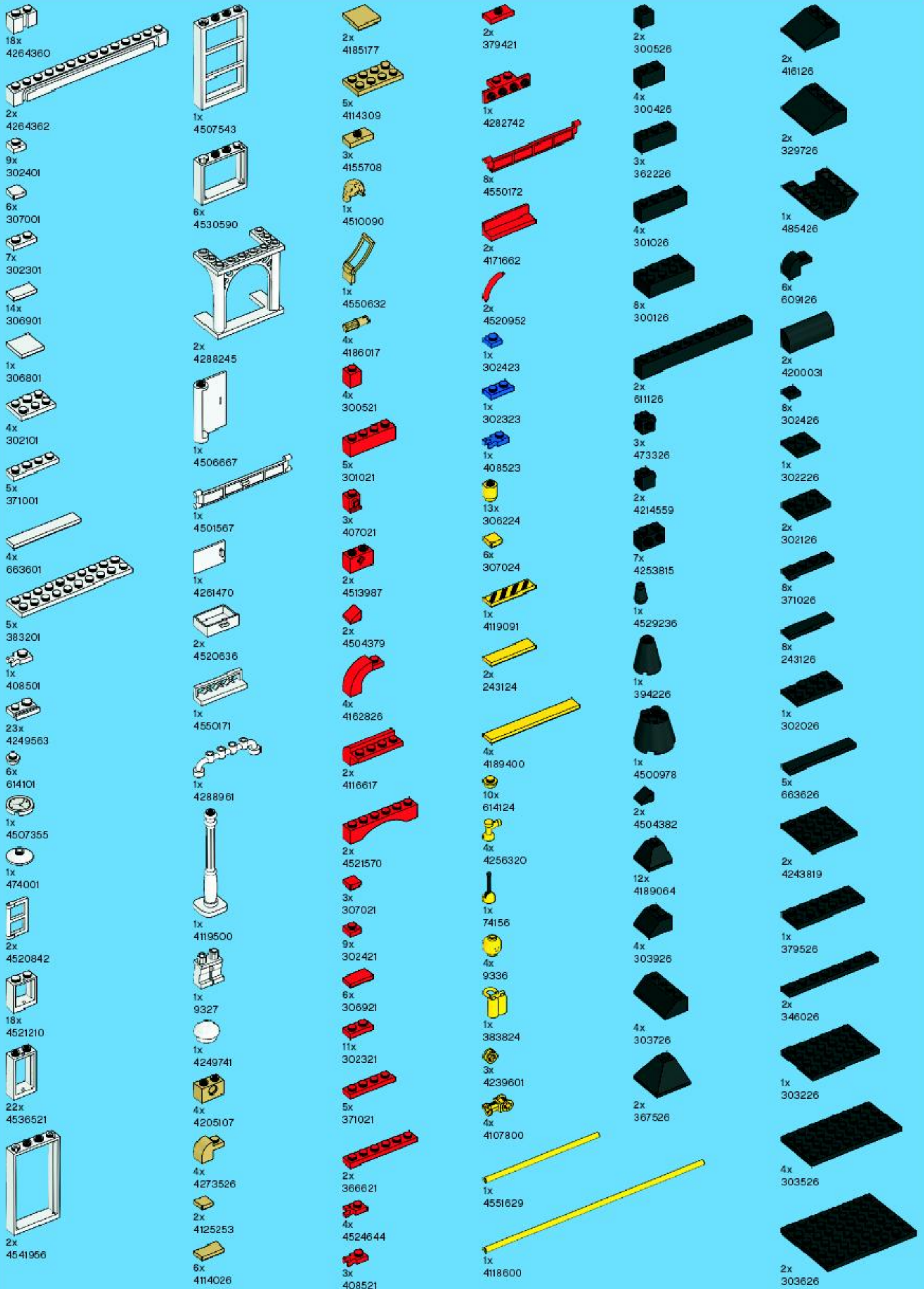

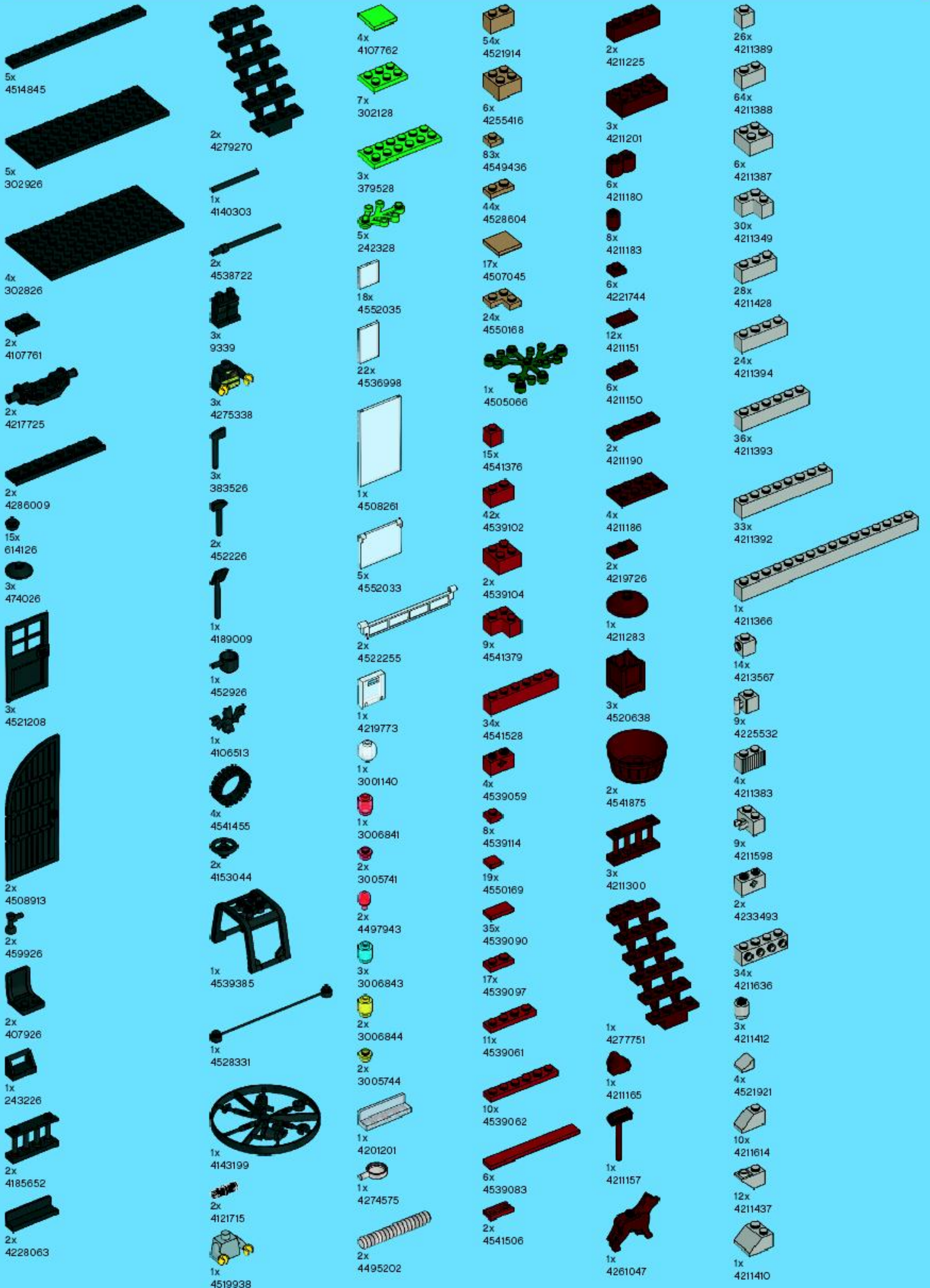

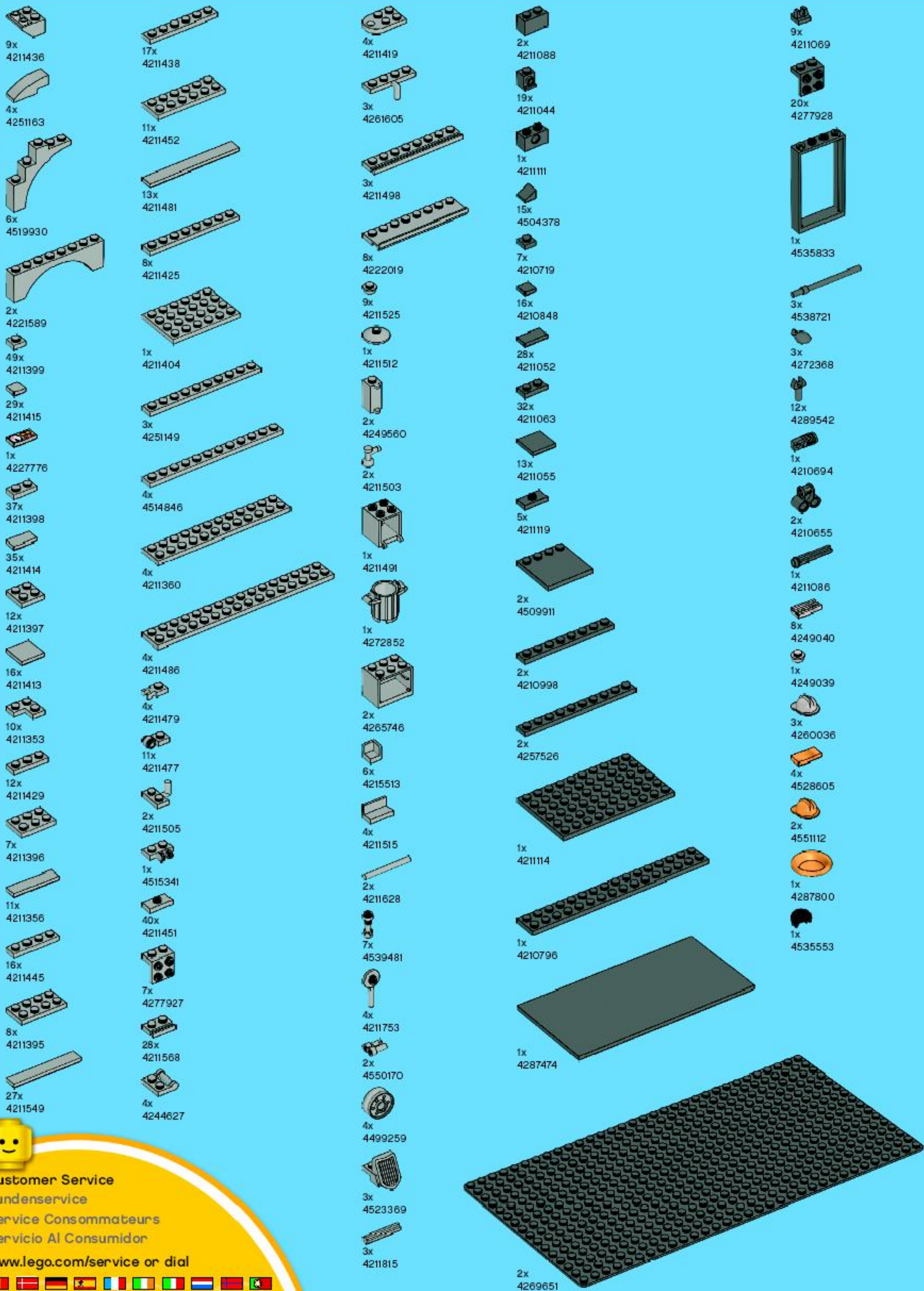

Customer Service
 Kundenservice
 Service Consommateurs
 Servicio Al Consumidor
www.lego.com/service or dial

00800 5346 5555 :

 1-800-422-5346 :



CREATOR

6753





CREATOR

6754



FREE! GRATIS! GRATUIT!



club

MAGAZINE™

www.LEGOclub.com



00800 5346 5555*



1-866-534-6258 • 1-877-518-5346

US & Canada only

Canada seulement

* FreePhone. Mobile charges may apply. * Numéro sans frais. Des frais peuvent s'appliquer avec les téléphones cellulaires. * Gebührenfrei. Kosten für Anrufe aus Mobilfunknetzen können anfallen. * Gratis telefoonsnummer van vaste lijn. * Deber etic gratis numerar, air du ringer fra fasttelefon. * Het gratis, airdu ringer fra en fast telefon.



VISIT THE WORLD'S
BIGGEST LEGO® SHOP!

www.LEGOshop.com

YES! I want to join the LEGO® Club FREE! OUI! Je veux m'abonner au Club LEGO® GRATUITEMENT! Ja! Ich möchte Mitglied im kostenlosen LEGO® Club werden. Ja! Ik wil graag GRATIS lid worden van de LEGO® Club. Ja! Jeg ønsker å melde meg inn i LEGO® Club gratis! Ja! Jag vill gå med i LEGO® Club GRATIS!

First name - Prénom
Vernam - Voornam
Förnamn - Förnamn

Last name - Nom de Famille
Name - Achternam
Efternamn - Efternamn

Date of Birth - Date de naissance
Geburtsdag - Geboortedatum
Födelsedato - Födelsedatum

Boy - Garçon
Junge - Jungen
Gutt - Pojke

Girl - fille
Mädchen - Meisje
Jente - Flicka

Street - Adresse
Strasse, Hausnr.
Street, house - Ådres

City - Ville
Ort - Woonplaats
Poststed - Postort

State
Prr.
County

Zip/Postcode - Code Postal
PLZ - Postcode - Postnummer

Country
Pays - Land

Please tick below if you would like to receive other communication from the LEGO Group. **Silvous aimeriez recevoir d'autres communications de la part de la compagnie LEGO, veuillez cocher ici.** Als u graag andere informatie van de LEGO Groep wilt ontvangen, kruis dan a.u.b. dit vakje aan. **Ich möchte über Produkte, Angebote, Aktionen und weitere interessante Themen von der LEGO Gruppe informiert werden* (Nicht ankreuzen).** Om du vill få annen informasjon fra LEGO Gruppen, slått kryss här. **Hvis du ønsker å motta annen informasjon fra LEGO Gruppen, merker du av her.**

Post - Poste
Per Post

Mail - Courriel
Per E-Mail
E-Mail

Ich möchte über Produkte, Angebote, Aktionen und weitere interessante Themen von sonstigen LEGO Partnerunternehmen informiert werden* (Nicht ankreuzen). Per Post Per E-Mail

Mail to: / Poster à:

BG29

LEGO® Club
P.O. Box 1157
Enfield, CT USA
06083-1157

Mail to:

BI09U

LEGO® Club
33 Both Road
Slough SL1 3UF
United Kingdom

Per Post on:

BI09C

LEGO® Club
Postfach 14 15
D-36243 Niederraulo

Stuur op naar:

BI09N

LEGO® Club
Postbus 40250
3504 AB Utrecht

Send til:

BI09O

LEGO® Club Norge
Postboks 58
1314 Vøyenengo

Skickas till:

BI09S

LEGO® Club Sverige
Ubox 841
202 29 Molmö

LEGO The English language version of the magazine can only be mailed to addresses in the US, Canada, the UK, and Republic of Ireland. Club membership is valid for two years and includes free copies of the LEGO Club Magazine. In the US and Canada please allow up to 6 weeks for delivery of your first magazine. In the UK and Republic of Ireland please allow six to 14 weeks for delivery of your first magazine. By signing this form you consent the LEGO Club to use your child's data for LEGO mailings. The data will only be used for LEGO mailings and will not be sold, rented or otherwise disclosed to any company outside the LEGO Company except for disclosure to companies acting as our agents to help us provide services requested by the child. This coupon is valid for one free membership per person, group or organisation. Photocopied coupons are accepted. **La version française du magazine peut être postée uniquement au Canada. L'abonnement est valide pour 2 ans et inclut des exemplaires gratuits du Magazine LEGO. Aux E-U, et au Canada, allouer 6 semaines pour la livraison initiale. En remplissant ce formulaire, vous consentez à ce que LEGO utilise les informations de votre enfant pour des envois postaux de LEGO. L'information sera utilisée uniquement pour des envois postaux par LEGO et ne sera en aucun cas, vendue, louée, échangée ou divulguée à d'autres compagnies autres que la compagnie LEGO, à l'exception des compagnies affiliées qui nous procurent des services auxquels l'enfant a fait la demande. Das deutschsprachige LEGO Club Magazin kann nur an Adressen in Deutschland, Österreich und der Schweiz verschickt werden. Die kostenlose Mitgliedschaft beinhaltet die Zusendung des LEGO Club Magazins und endet nach zwei Jahren. Mit der Anmeldung gehen Sie keine Verpflichtungen ein. Es kann bis zu drei Monate dauern, bis das erste Magazin zugestellt wird. Mit Ihrer Unterschrift erklären Sie sich damit einverstanden, dass die Daten Ihres Kindes zum Zweck einer LEGO Club Mitgliedschaft von der LEGO Gruppe gespeichert und verarbeitet werden. Die Daten werden vertraulich behandelt, nicht an Dritte weitergegeben und nicht veräußert. Externe Dienstleister erhalten Ihre Daten nur, soweit es für die Abwicklung von LEGO Kommunikation erforderlich ist. Wenn Sie von uns nicht mehr kontaktiert werden möchten, können Sie der Verwendung Ihrer Daten für Werbezwecke widersprechen unter: 00800 5346 5555 (Anruf gebührenfrei, Kosten für Anrufe aus Mobilfunknetzen können abweichen). * Die Einwilligungen kann ich jederzeit (insgesamt oder zum Teil) ohne Einfluss auf die LEGO Club Mitgliedschaft bei der LEGO Gruppe widerrufen. Het LEGO Club Magazine kan alleen worden gestuurd naar adressen in Nederland. Het lidmaatschap is 2 jaar geldig en geeft recht op toezending van het gratis LEGO Club Magazine. Het eerste magazine zal na 12 tot 14 weken toegestuurd worden. Het lidmaatschap kan op ieder moment opgezegd worden. Door dit formulier te tekenen geeft u de LEGO Club toestemming om bovenstaande gegevens te gebruiken voor het toesturen van LEGO mailings. Uw gegevens worden uitsluitend gebruikt voor mailings van LEGO en zullen niet worden verkocht, verhuurd of op welke wijze dan ook verstrekt aan derden buiten de LEGO Groep, uitgezonderd de organisaties die namens ons optreden om de service te verlenen waar uw kind om gevraagd heeft. Den norske utgaven av magasinet sendes kun til adresser i Norge. Medlemskapet i klubben gjelder i 2 år og inkluderer gratisutgaver av LEGO Magazine. Påregnet opp til seks uker leveringstid for første magasin. Ved å undertegne dette skjemaet, gir du ditt samtykke til at LEGO Club kan bruke opplysningene om barnet ditt i LEGO forsendelser. Dataene vil utelukkende bli brukt i LEGO forsendelser og vil ikke bli solgt utleid eller på annen måte gjøres tilgjengelig for selskaper utenfor LEGO gruppen, unntatt selskaper som er våre agenter og som hjelper oss å tilby tjenestene barnet etterspør. Dette skjemaet gjelder for ett gratis medlemskap per person, gruppe eller organisasjon. Den svenska versionen av tidningen kan endast skickas till adresser i Sverige. Club-medlemskapet är giltigt i 2 år och innefattar gratis exemplar av LEGO Club Magazine. Vänligen räkna med 6 veckor för leverans av din första tidning. Genom att skicka in det här formuläret godkänner du att LEGO Club använder barnets uppgifter för LEGO utskick. Uppgifterna kommer bara att användas för LEGO utskick och kommer inte att säljas, hyras ut eller vidarebefordras till något företag som inte tillhör LEGO Gruppen, med undantag av företag som agerar som våra ombud för att tillhandahålla tjänster som barnet har begärt. Den här kupongen gäller för ett gratis medlemskap per person, grupp eller organisation.**

Parent's signature - Signature d'un parent - Unterschrift Erziehungsberechtigter/

Håndskrevet underskrift - Førelses/Foresettes underskrift - Forældres/Ärnsunderskrift

Date
Datum
Dato

WIN LEGO® PRODUCTS

Fill out a survey and you might WIN a cool LEGO product!
NO PURCHASE NECESSARY

Open to all residents where not prohibited

Go to www.acnielsen.aim.dk/LEGO to fill out a survey for a chance to win a LEGO product.

WIN LEGO® PRODUCTEN

Vul een enquêteformulier in en maak kans op een cool LEGO® product!

Kopen niet nodig

Iedereen uit landen waar geen enquêteverbod geldt mag deelnemen.

Ga naar www.acnielsen.aim.dk/LEGO, vul een enquêteformulier in en maak kans op een LEGO product.

GEWINNE LEGO® PRODUKTE

Nimm an der Umfrage teil und GEWINNE ein tolles LEGO® Produkt!

Die Teilnahme am Gewinnspiel führt zu keinerlei

Kaufverpflichtungen

Teilnahme in allen nicht ausgeschlossenen Ländern möglich

Wir verlosen unter allen Teilnehmern der Umfrage auf

www.acnielsen.aim.dk/LEGO LEGO Produkte.

GAGNE DES PRODUITS LEGO®

Réponds à un questionnaire et tu pourrais GAGNER un produit LEGO® très cool !

Aucune obligation d'achat.

Ouvert à tous les résidents des pays autorisés.

Visite www.acnielsen.aim.dk/LEGO pour répondre à un questionnaire et avoir une chance de gagner un produit LEGO.

レゴ®製品を「当てよう」

アンケートに記入して、かっこいいレゴ®製品を当てよう！

お買い上げの必要はありません。

禁止されていない限り、すべての皆様にご利用いただけます。

www.acnielsen.aim.dk/LEGOにアクセスして、アンケートにご記入ください。当選者にはレゴ製品を差し上げます。

www.nielsen.com/LEGO



©2009 The LEGO Group. 45 65 202