



World Racers



8863



1

5

1

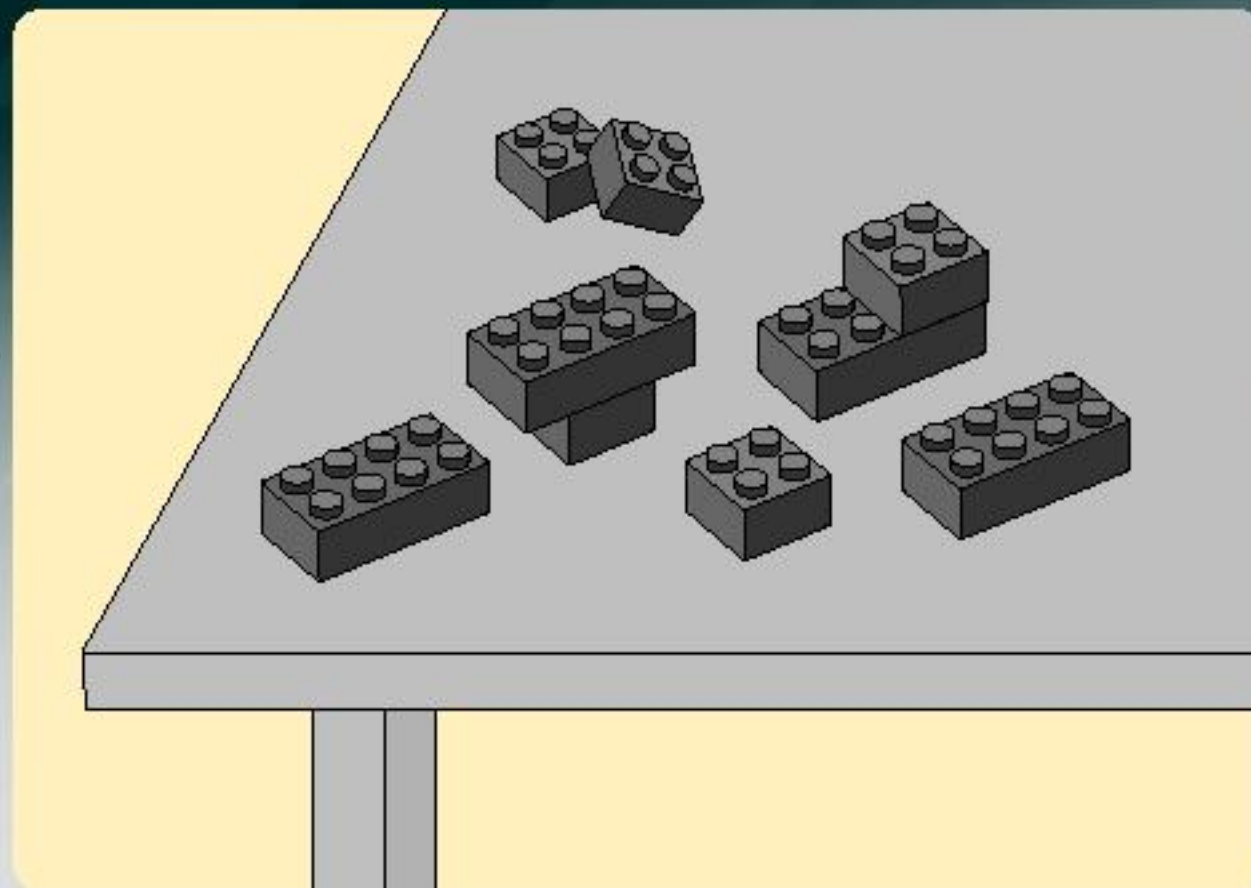
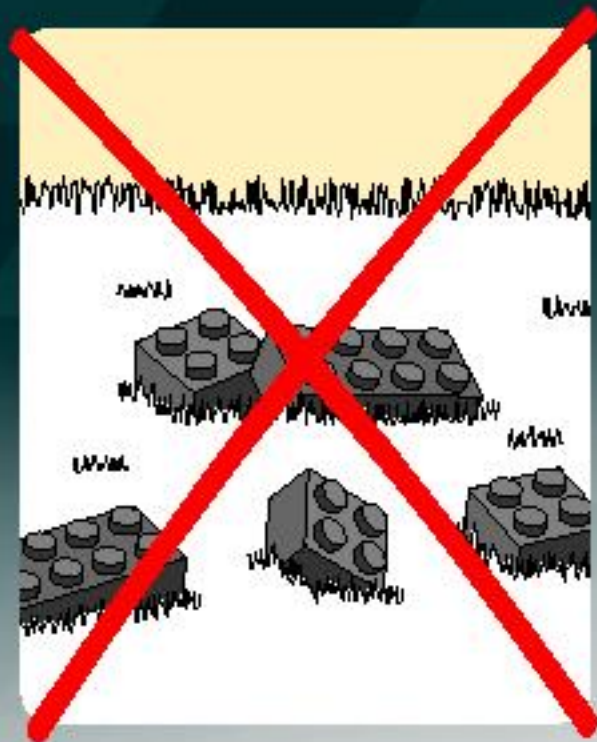

2

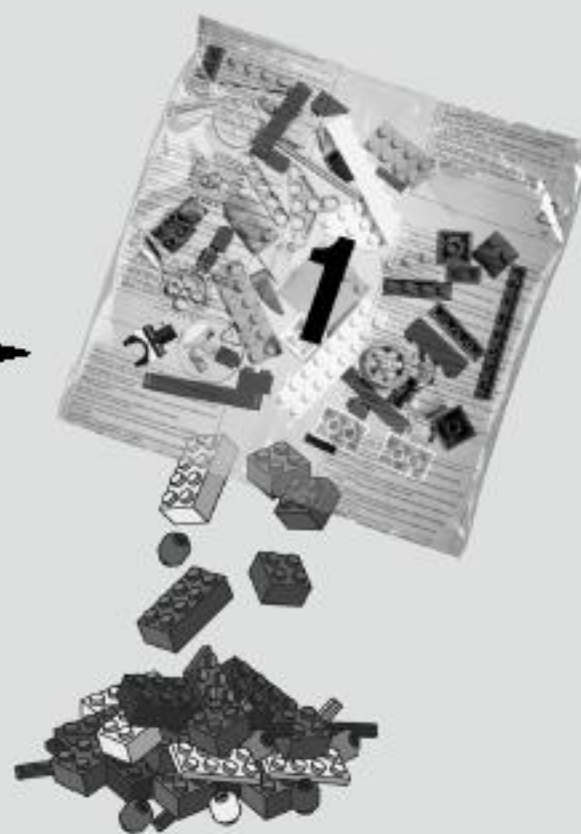

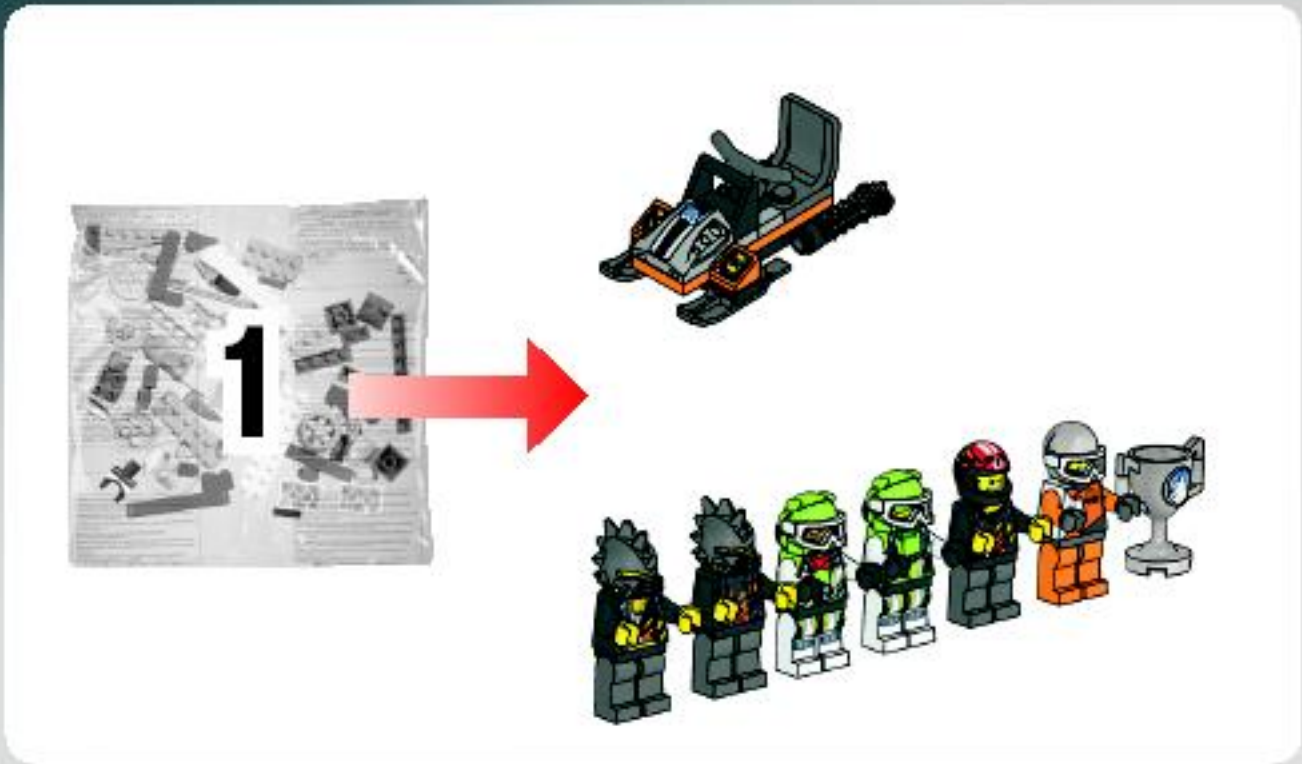

3

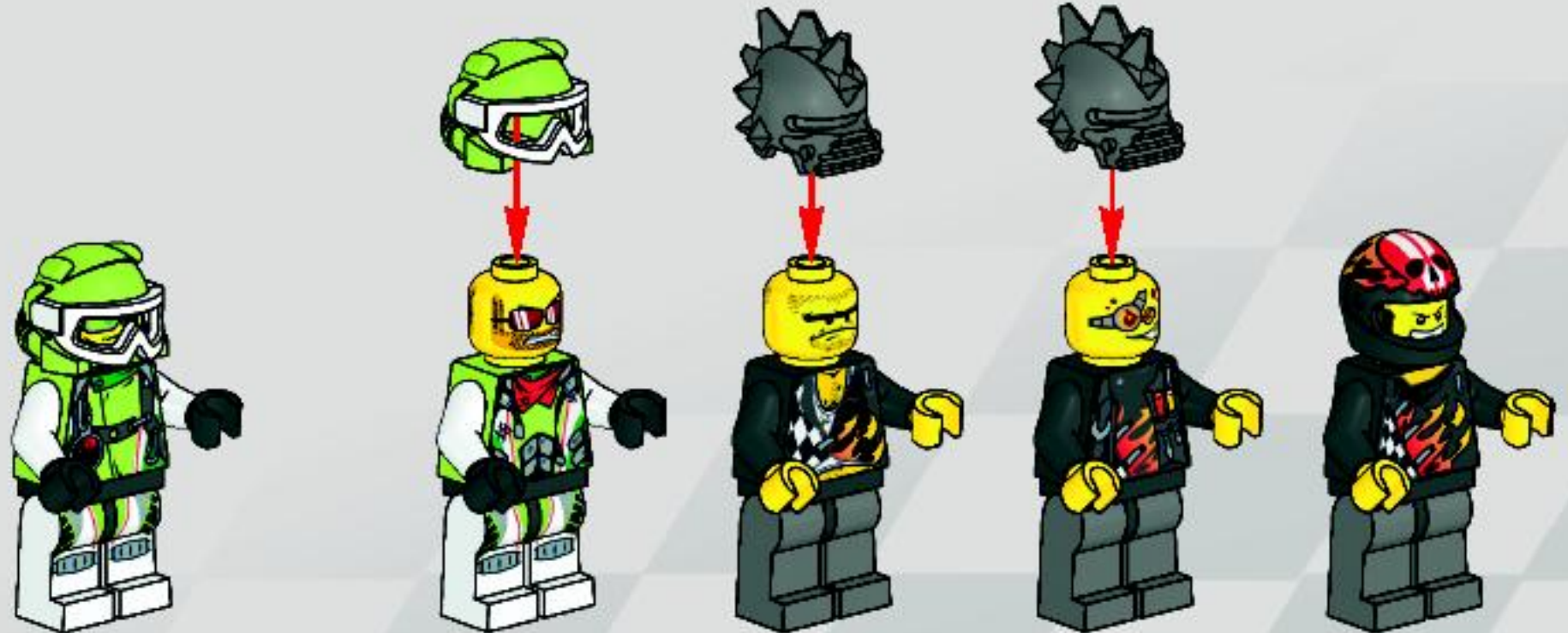
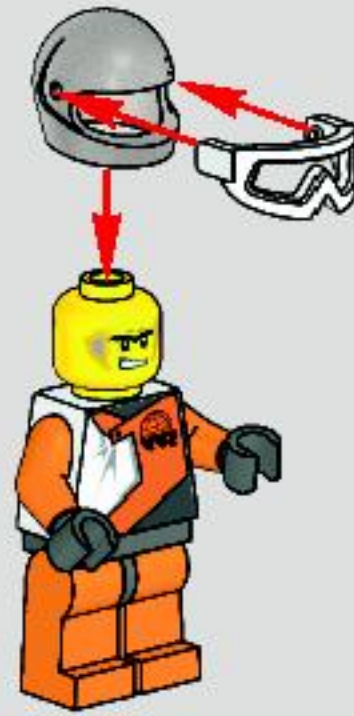
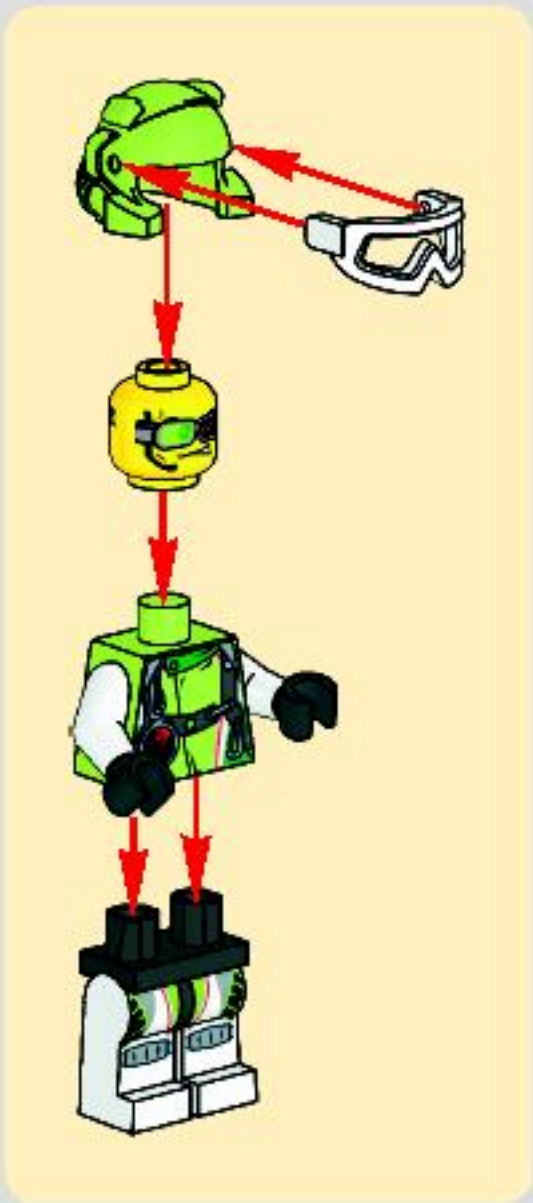



1x

1

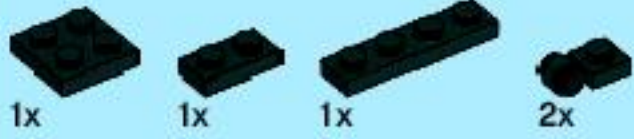

1x

1x

1x

2x

2

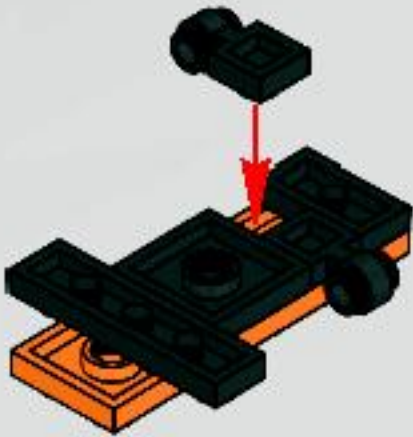

2x

3



2x



2x

4

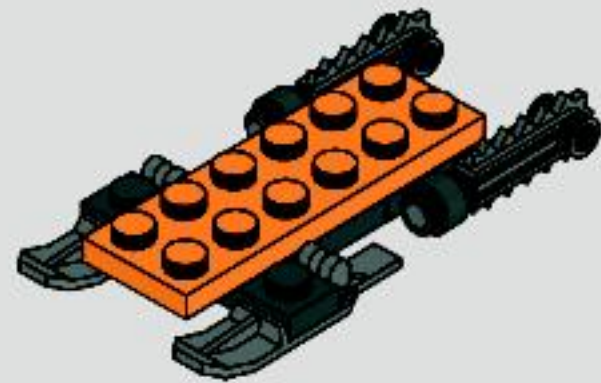



1x



1x



1x

5

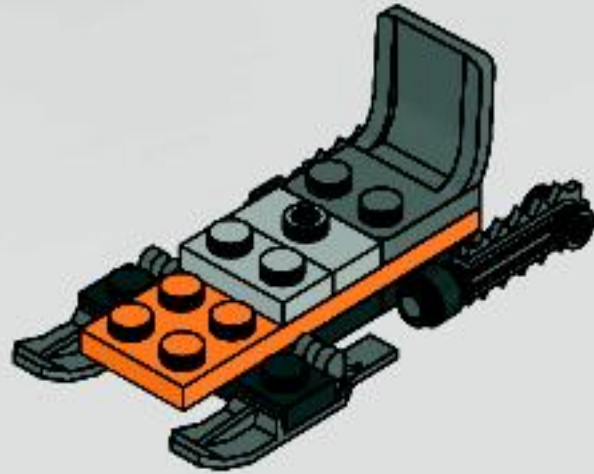

1x



1x

7

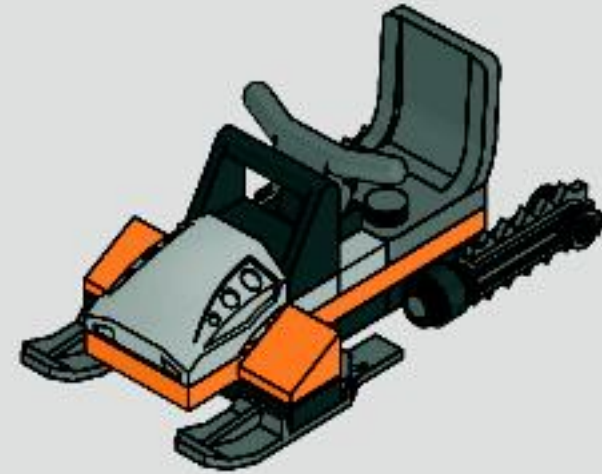

1x



1x



2x

6

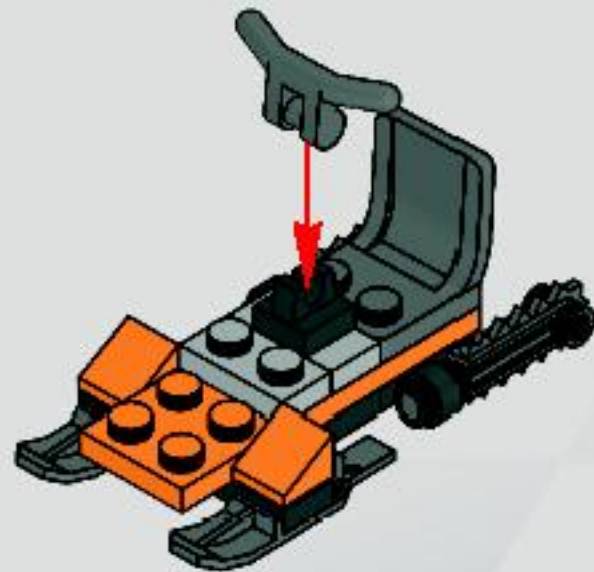

8



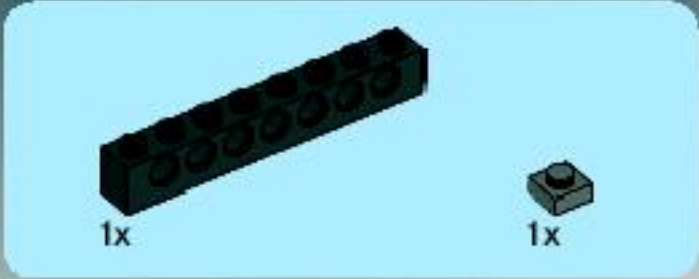
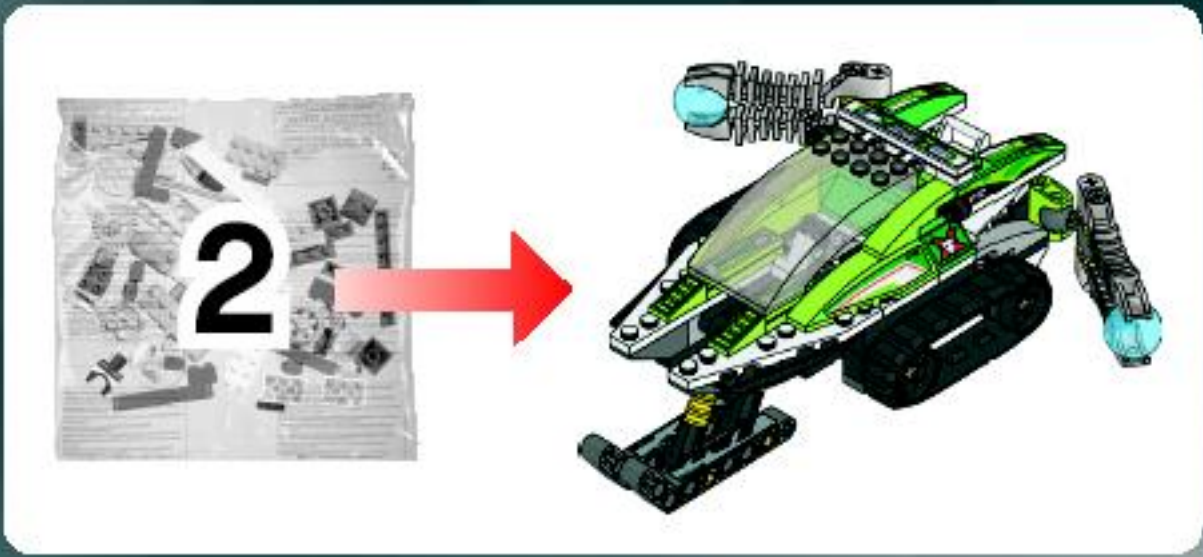

1

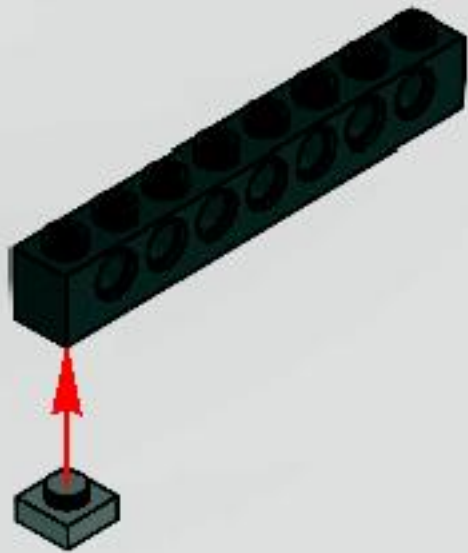

2

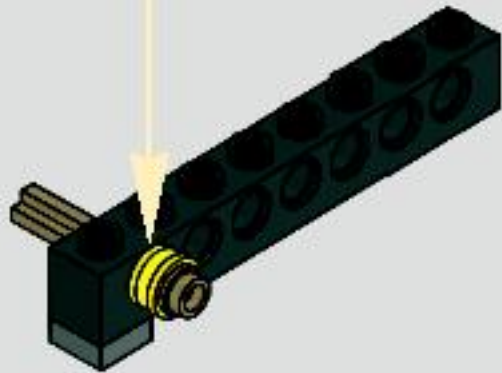
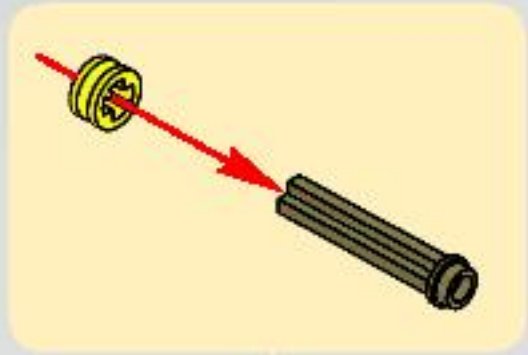

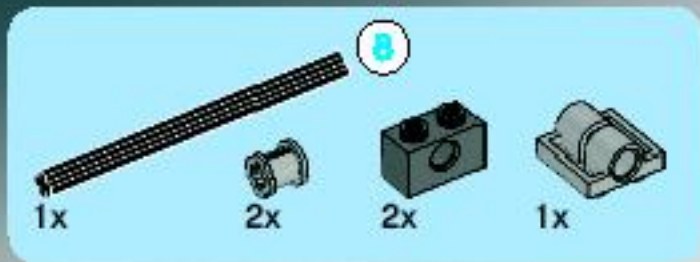

3

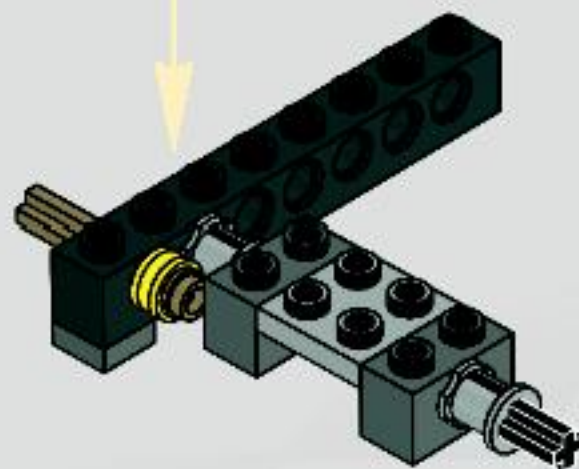
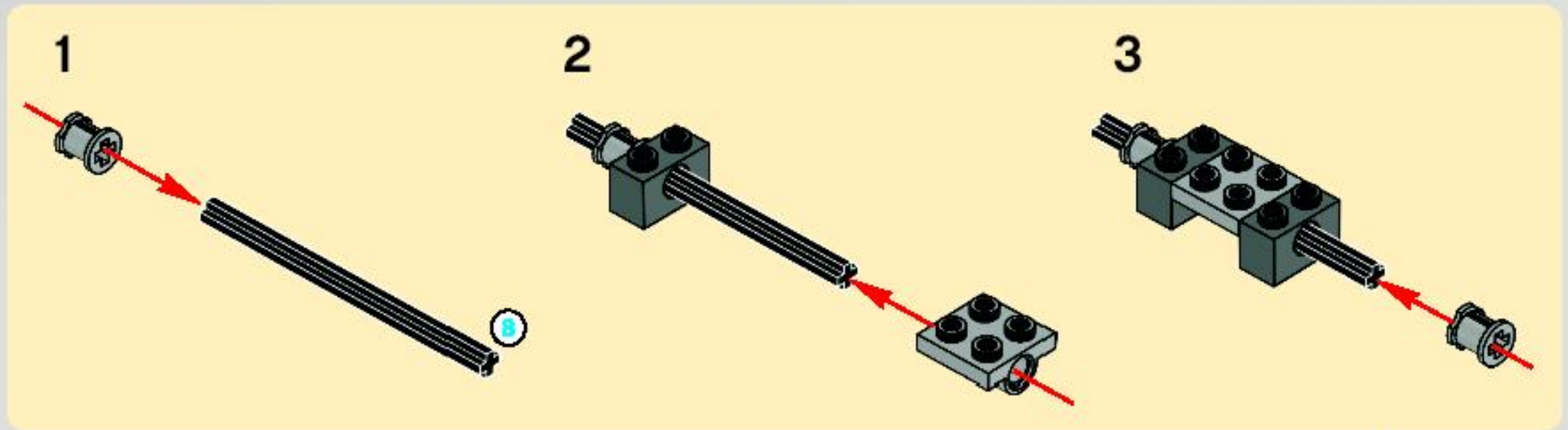

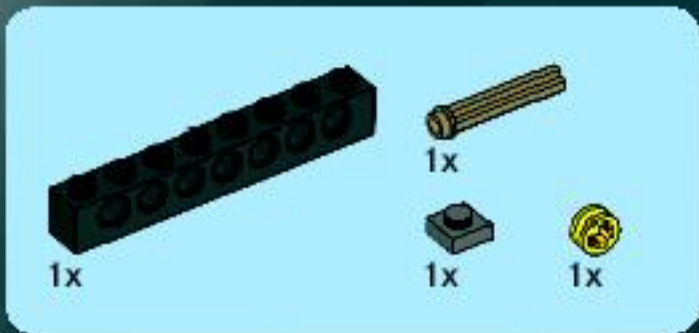

4

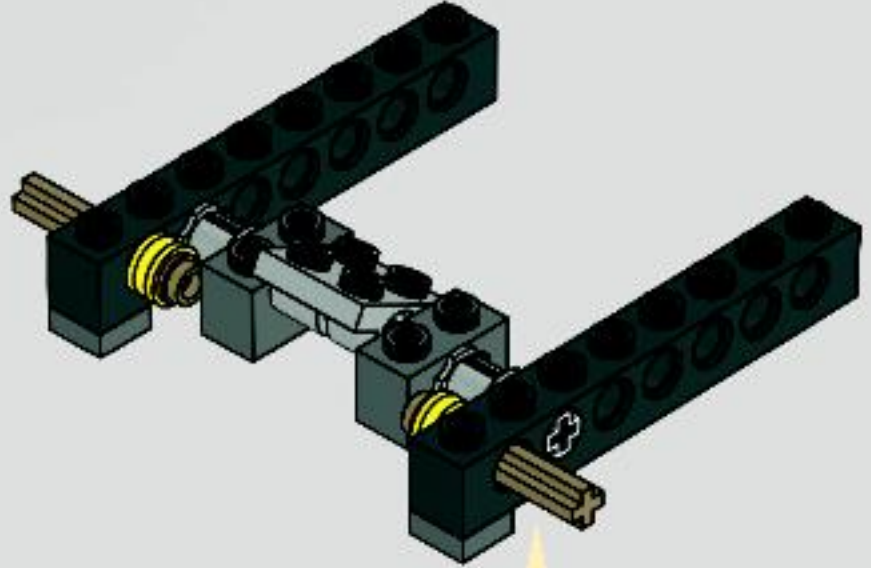
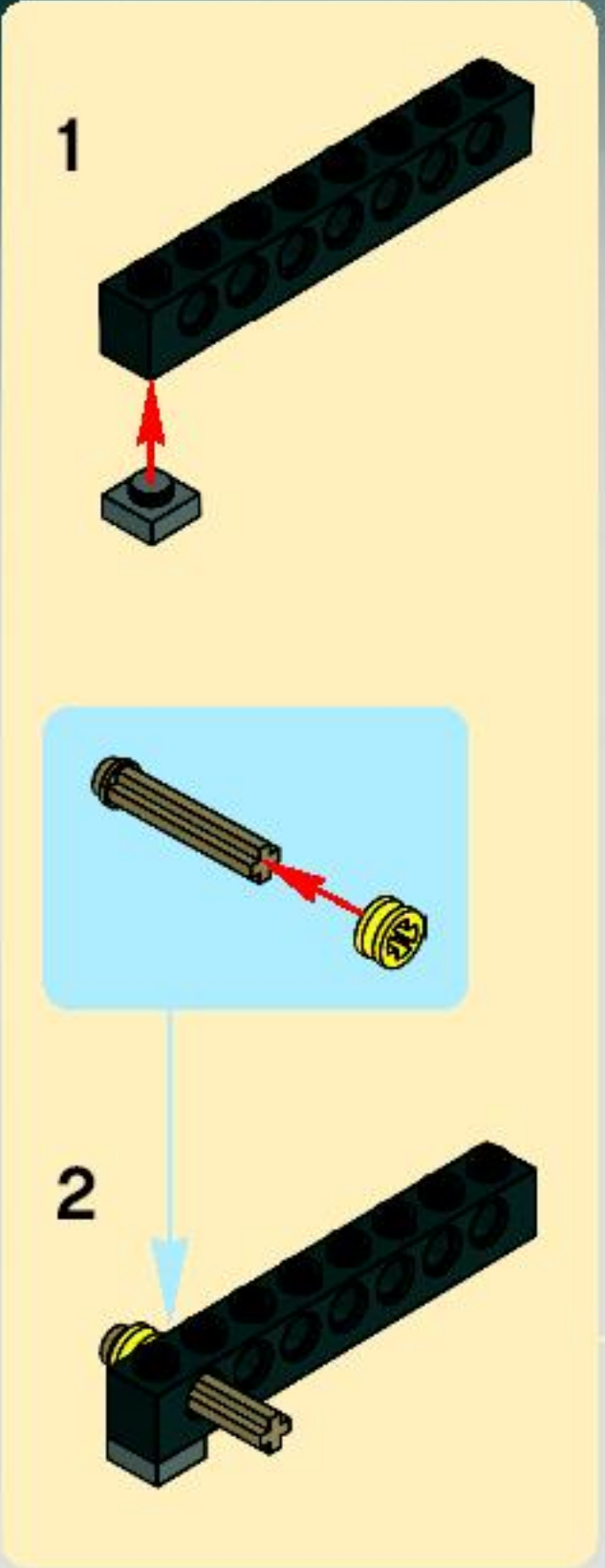



5

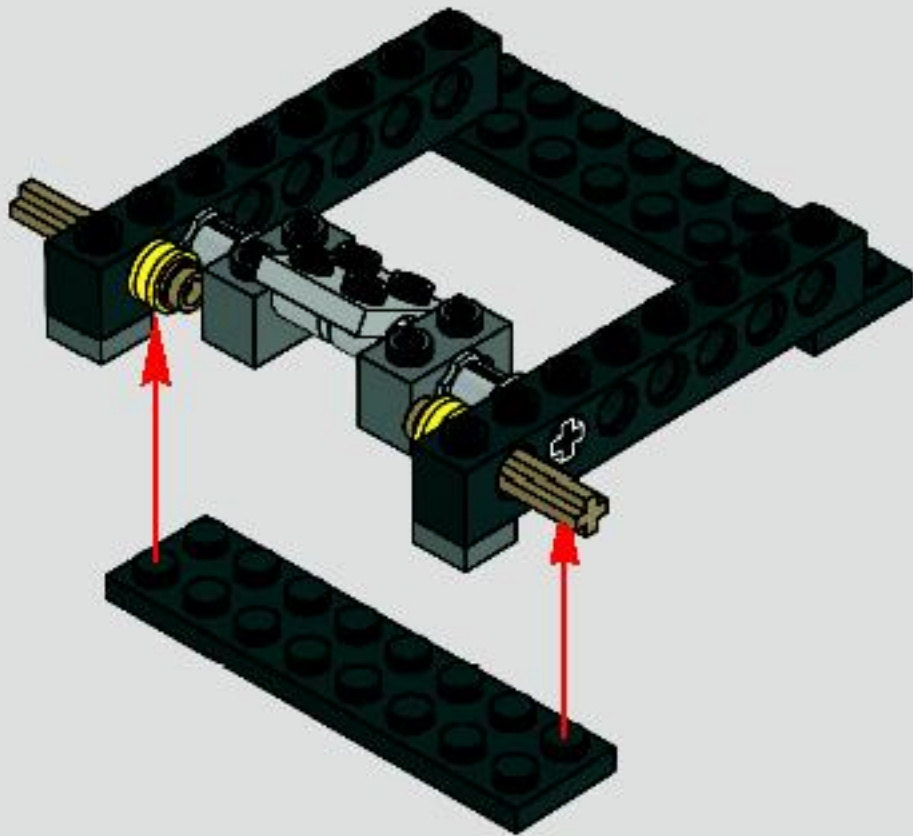

6

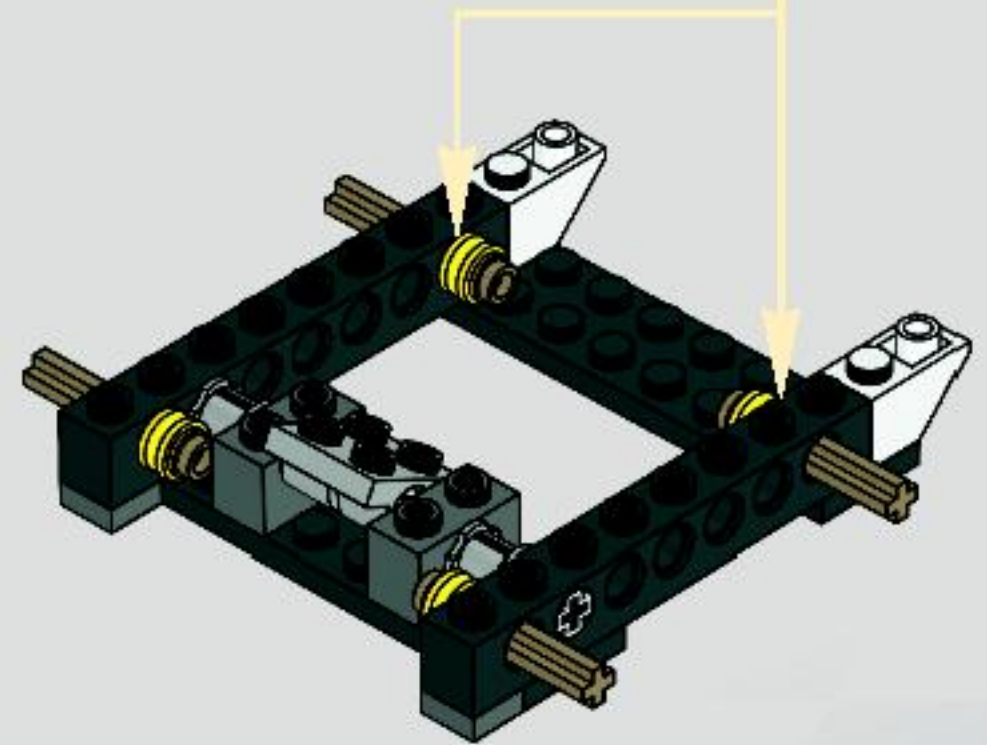
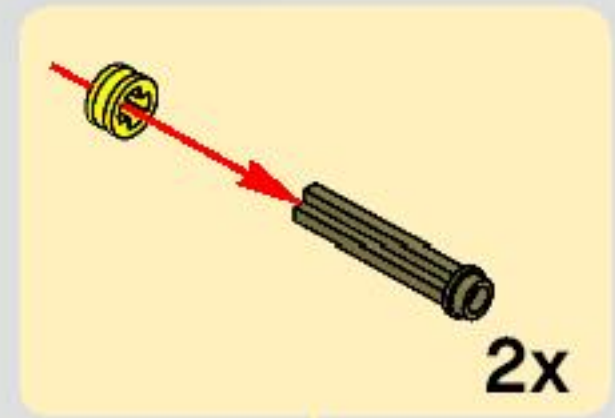



2x



2x

7

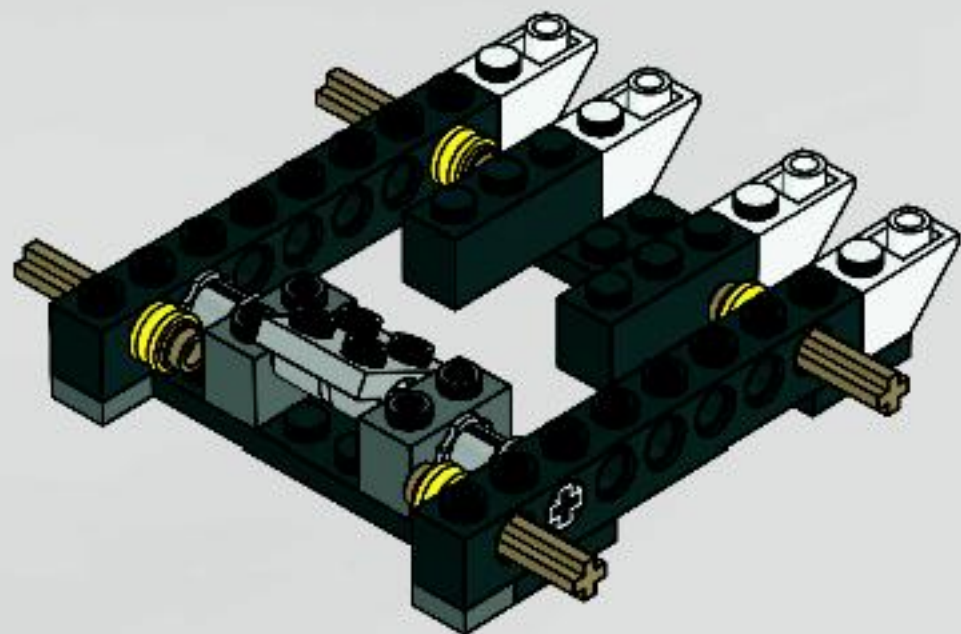

1x

8

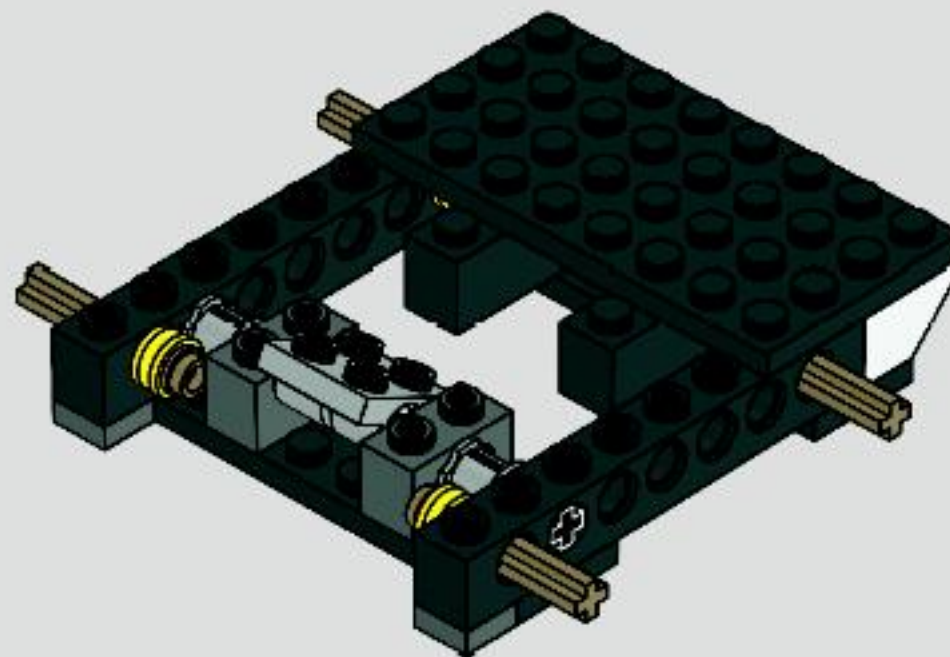



4x

9

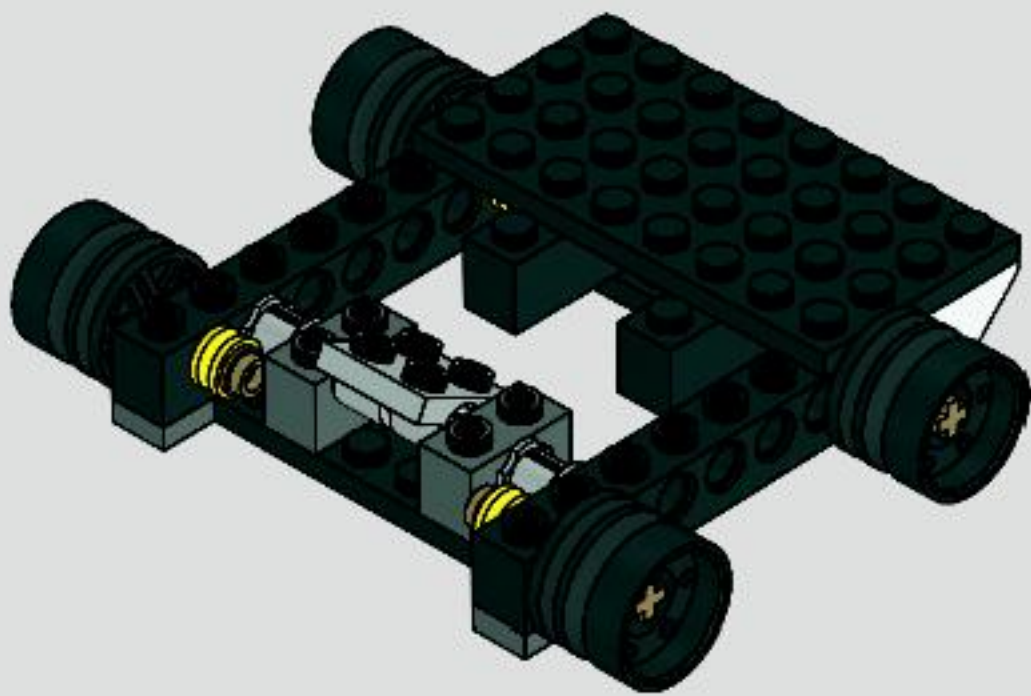

2x



4x

10

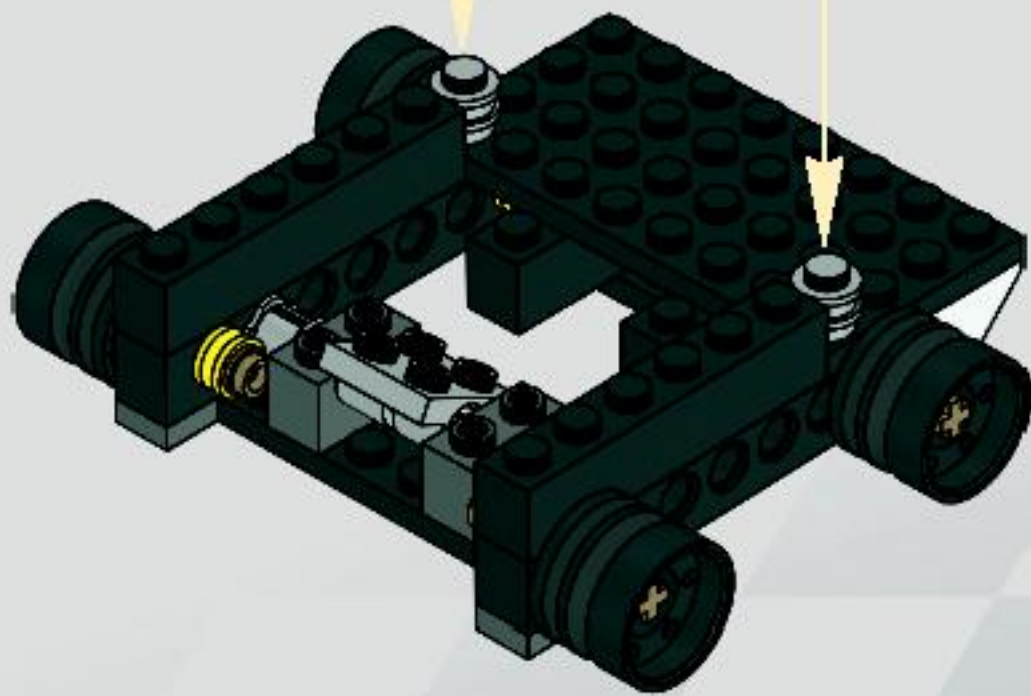
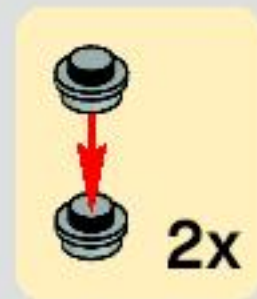

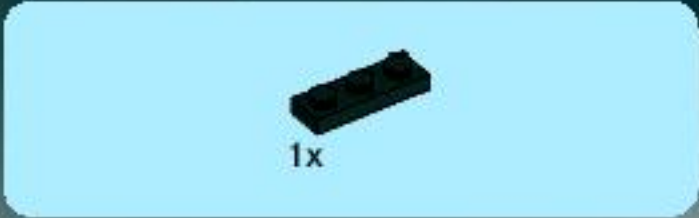

1



2

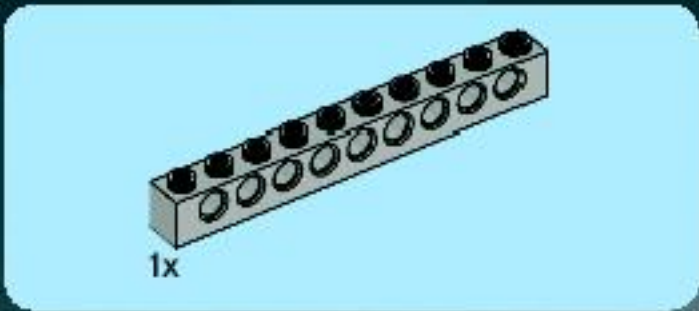

3



4

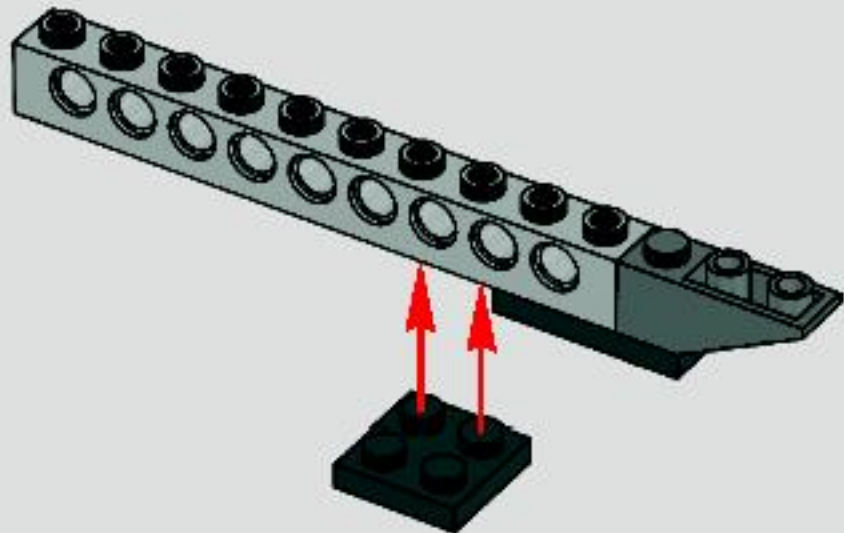



5

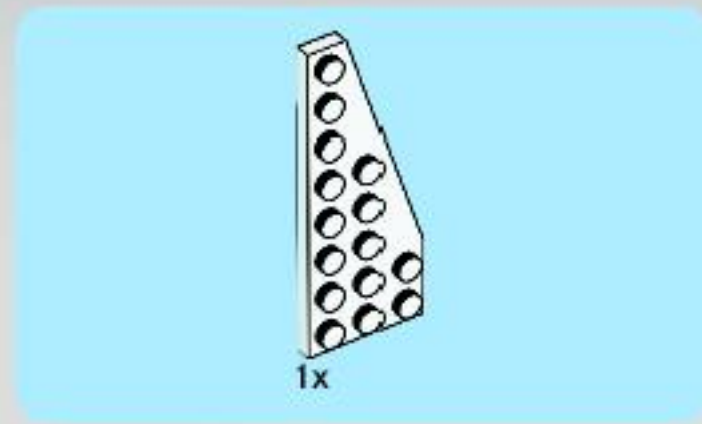
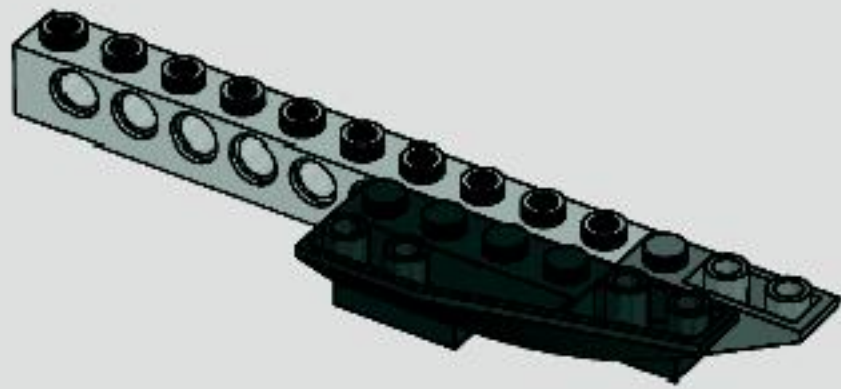

6





7

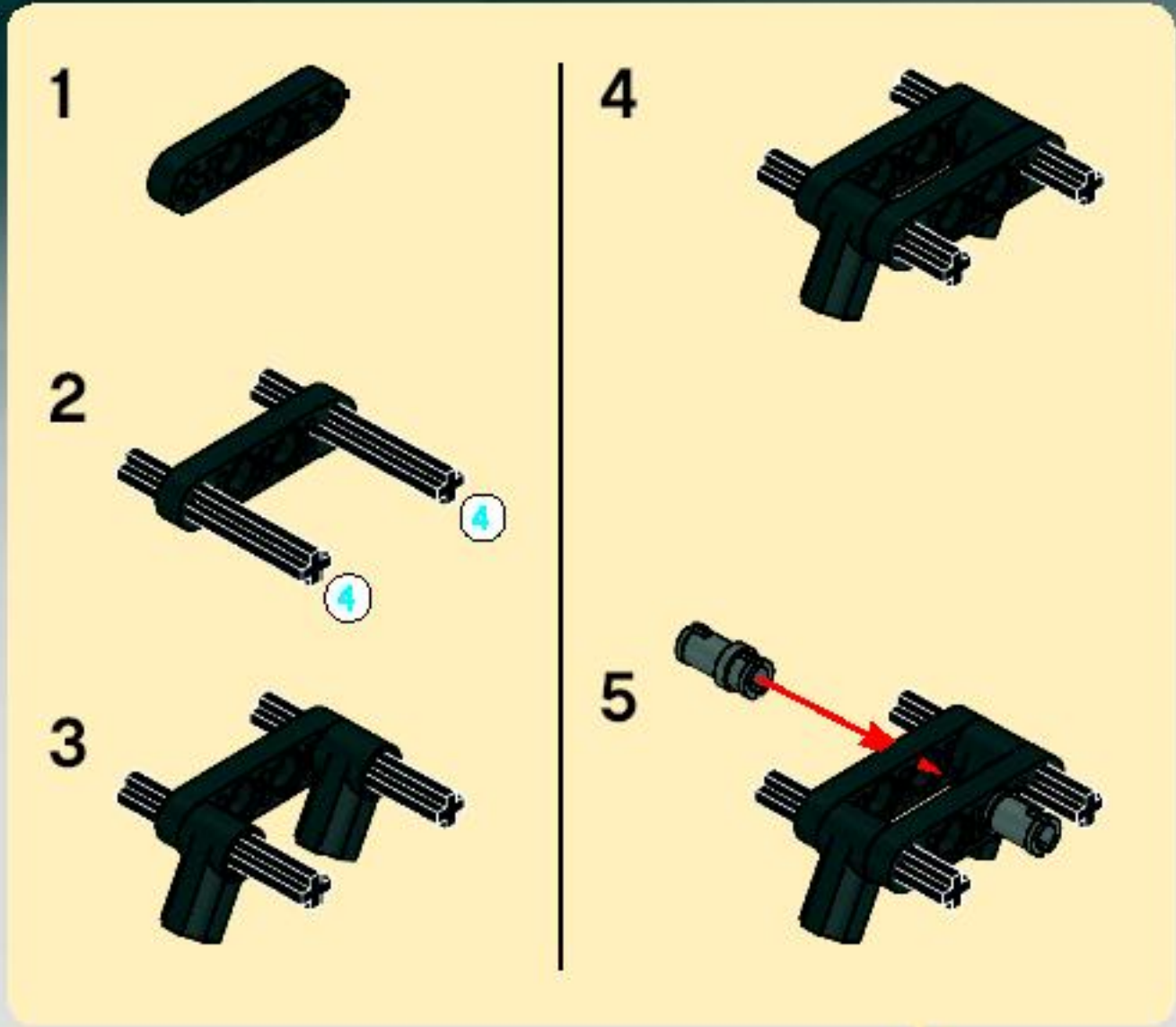



1

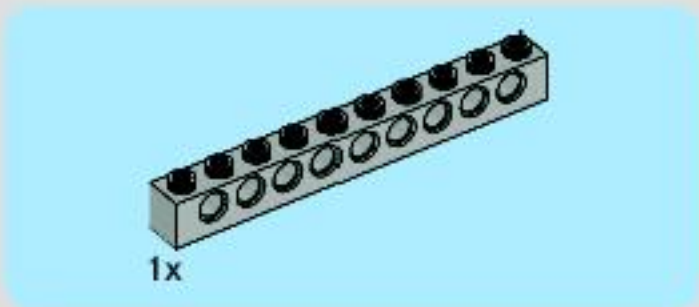

2

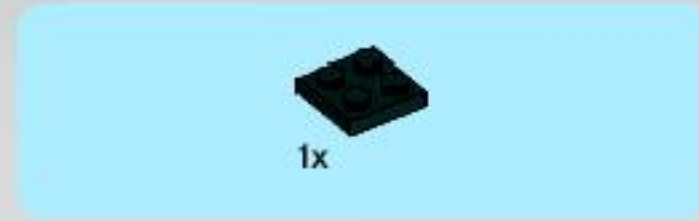

1x

3

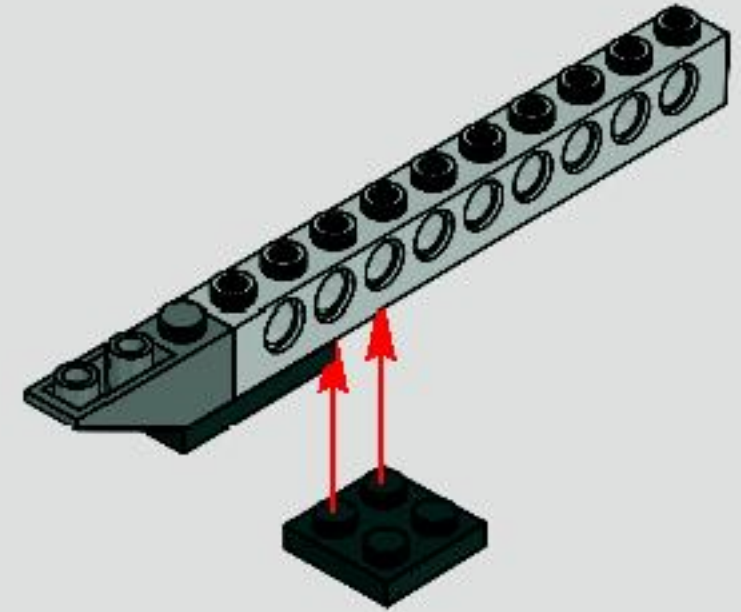

4



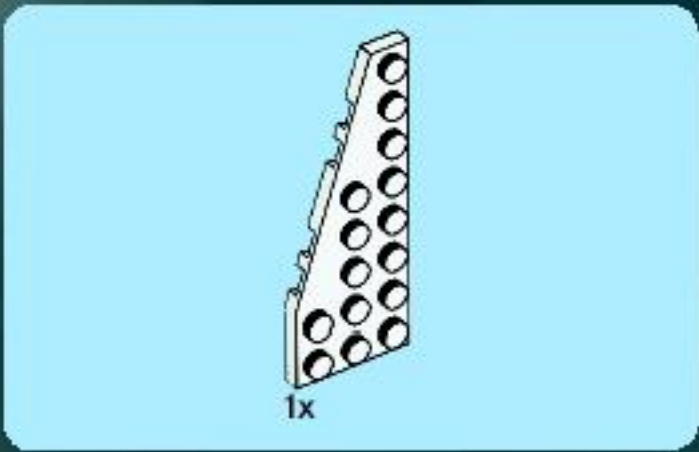

5



6

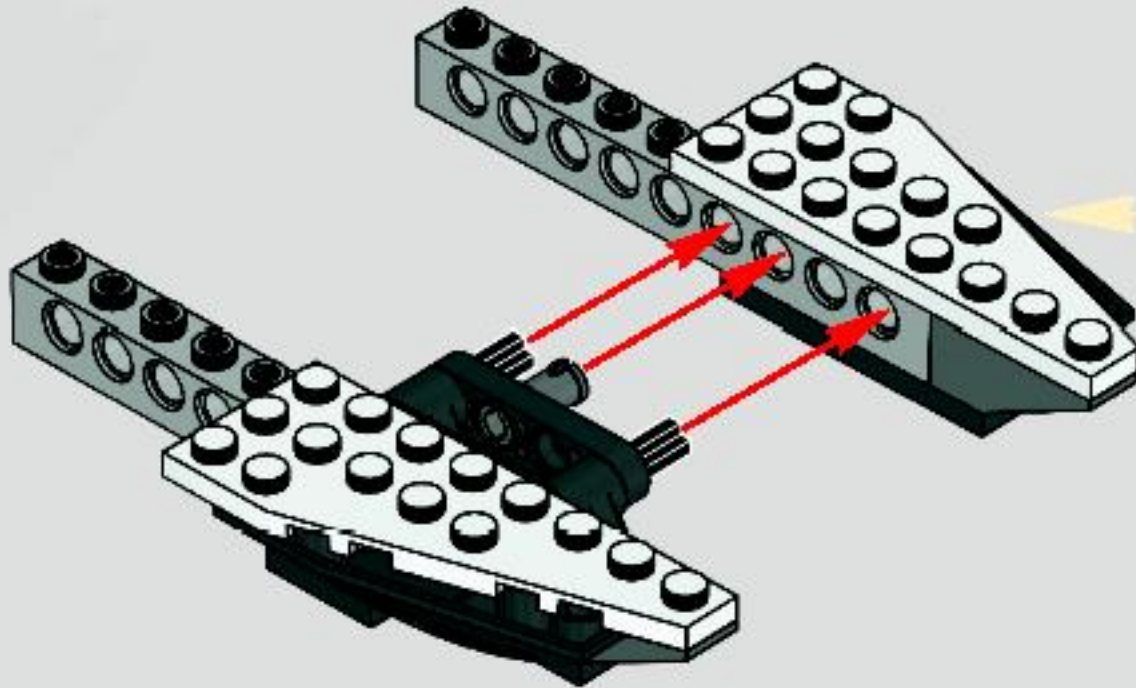

7

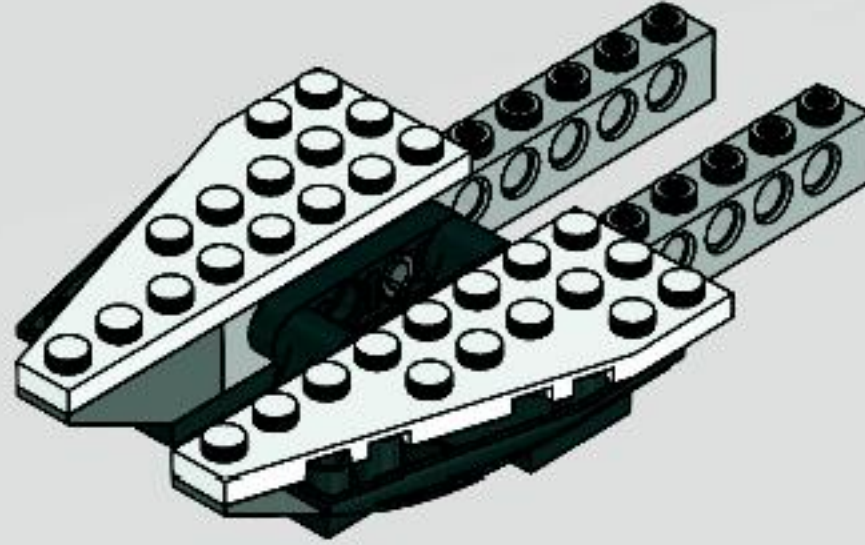

11

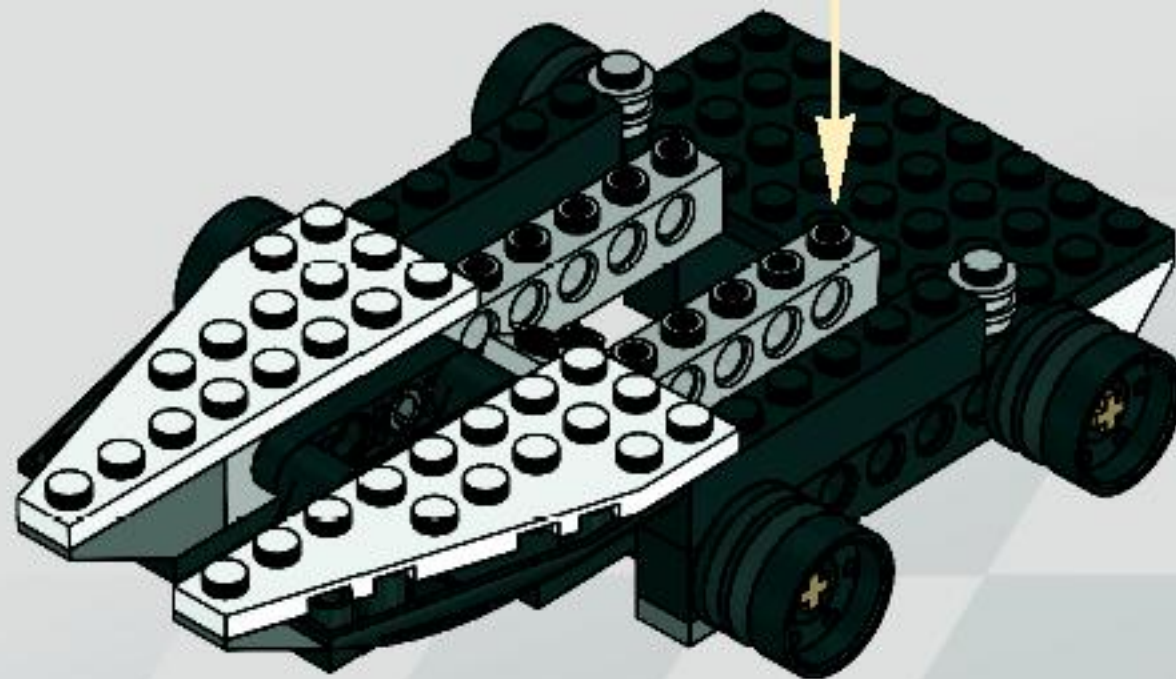



1x

12

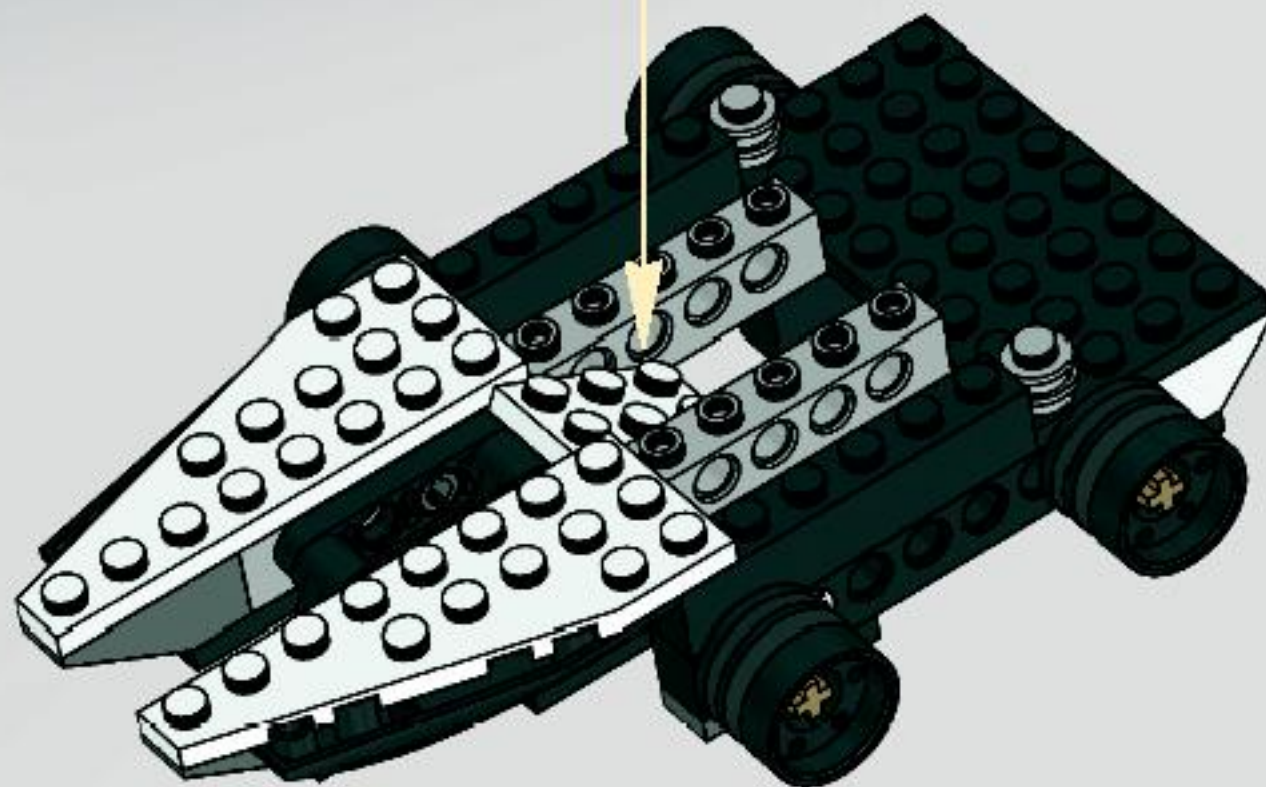



2x



2x

13

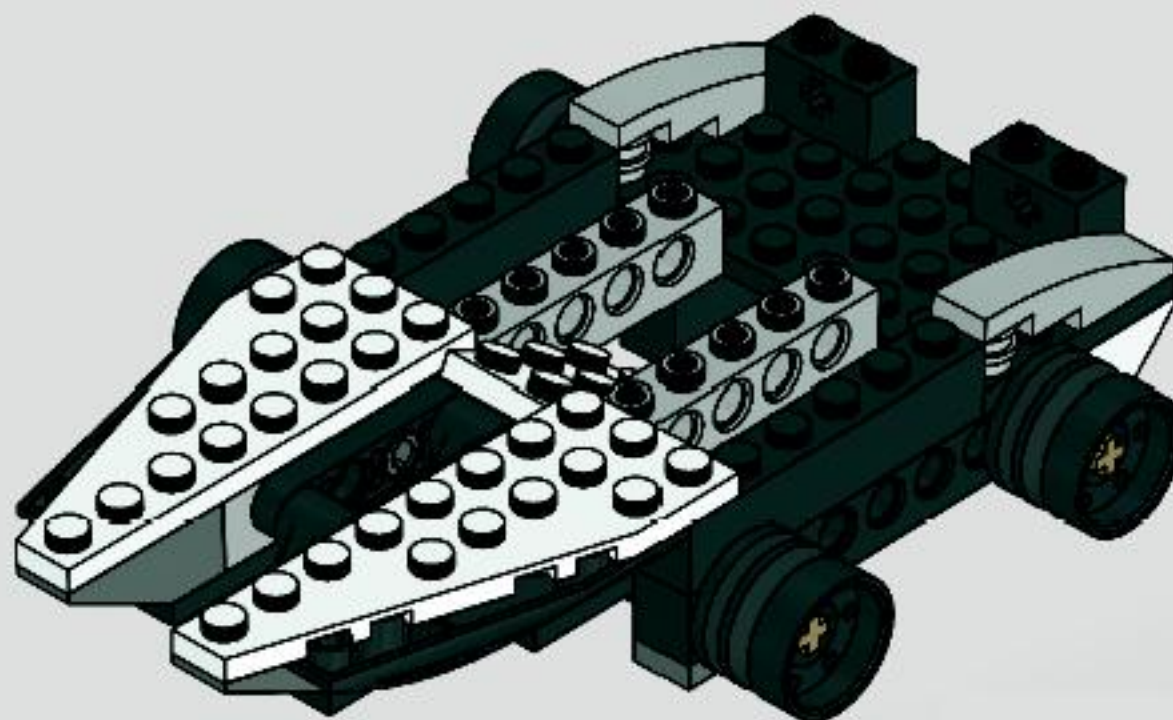



1x



2x

14

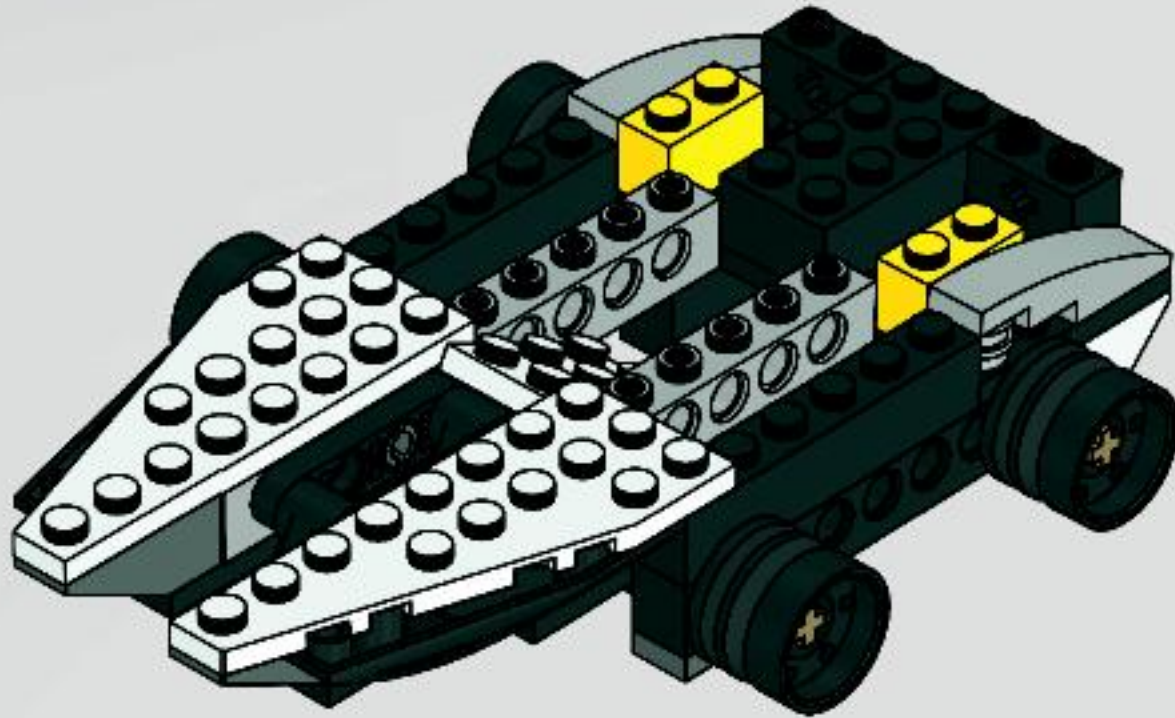

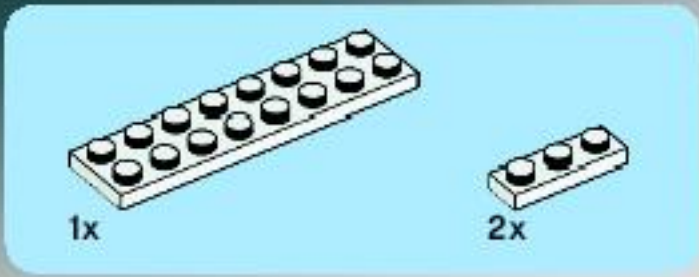

15

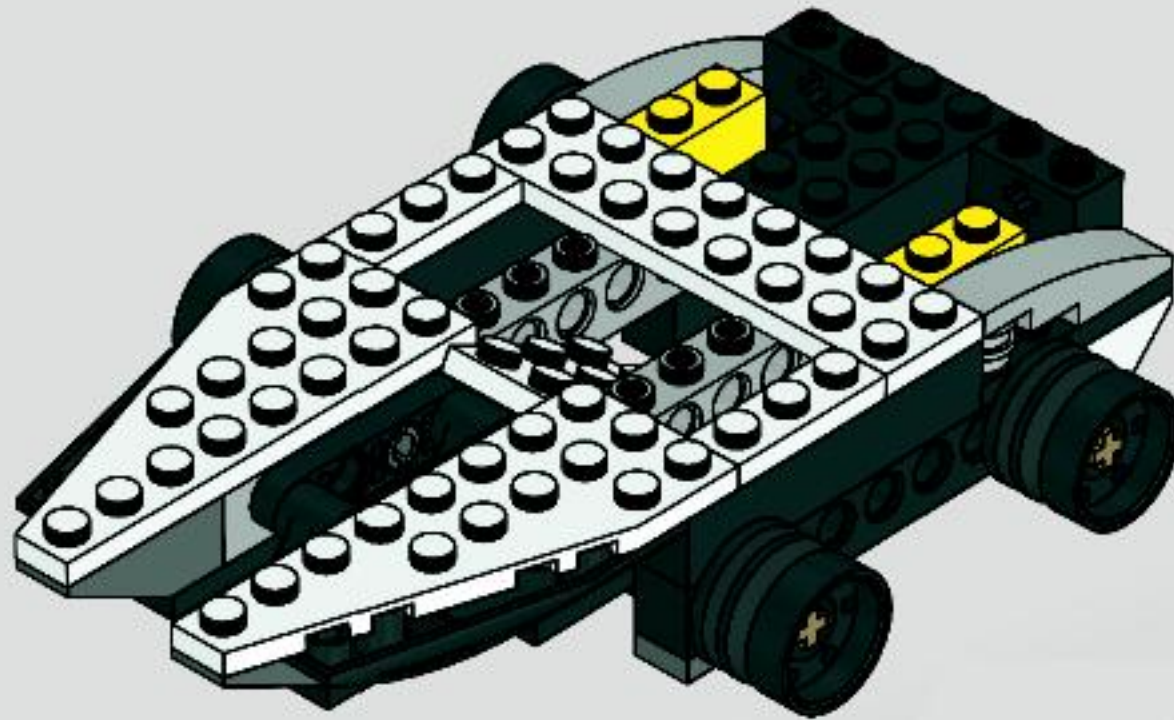

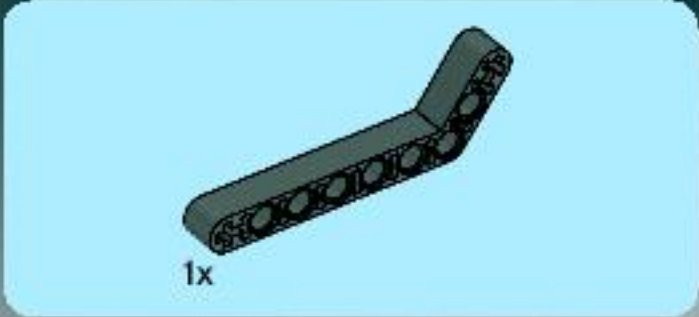
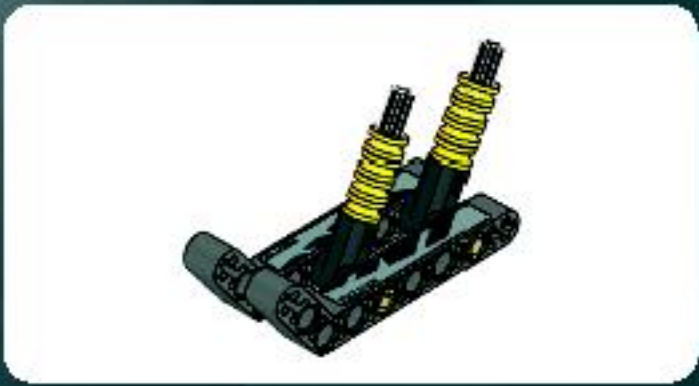

1

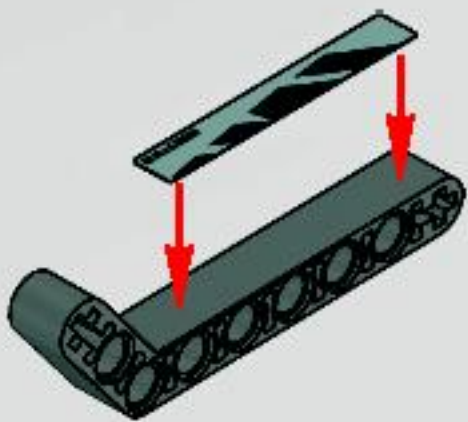

2

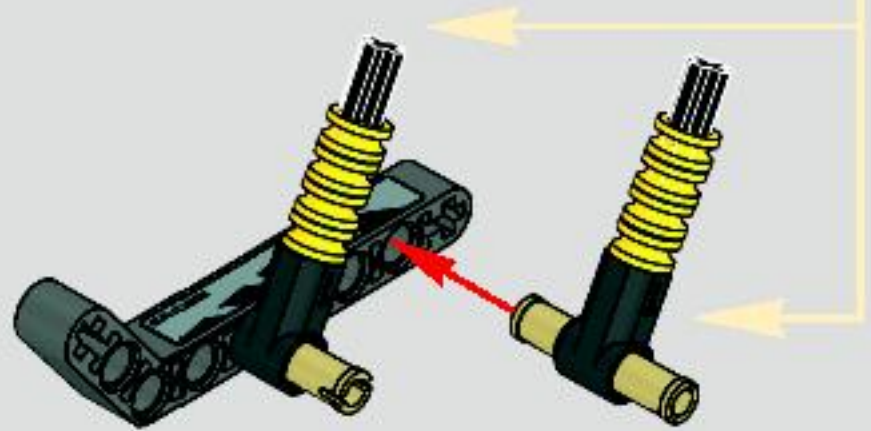
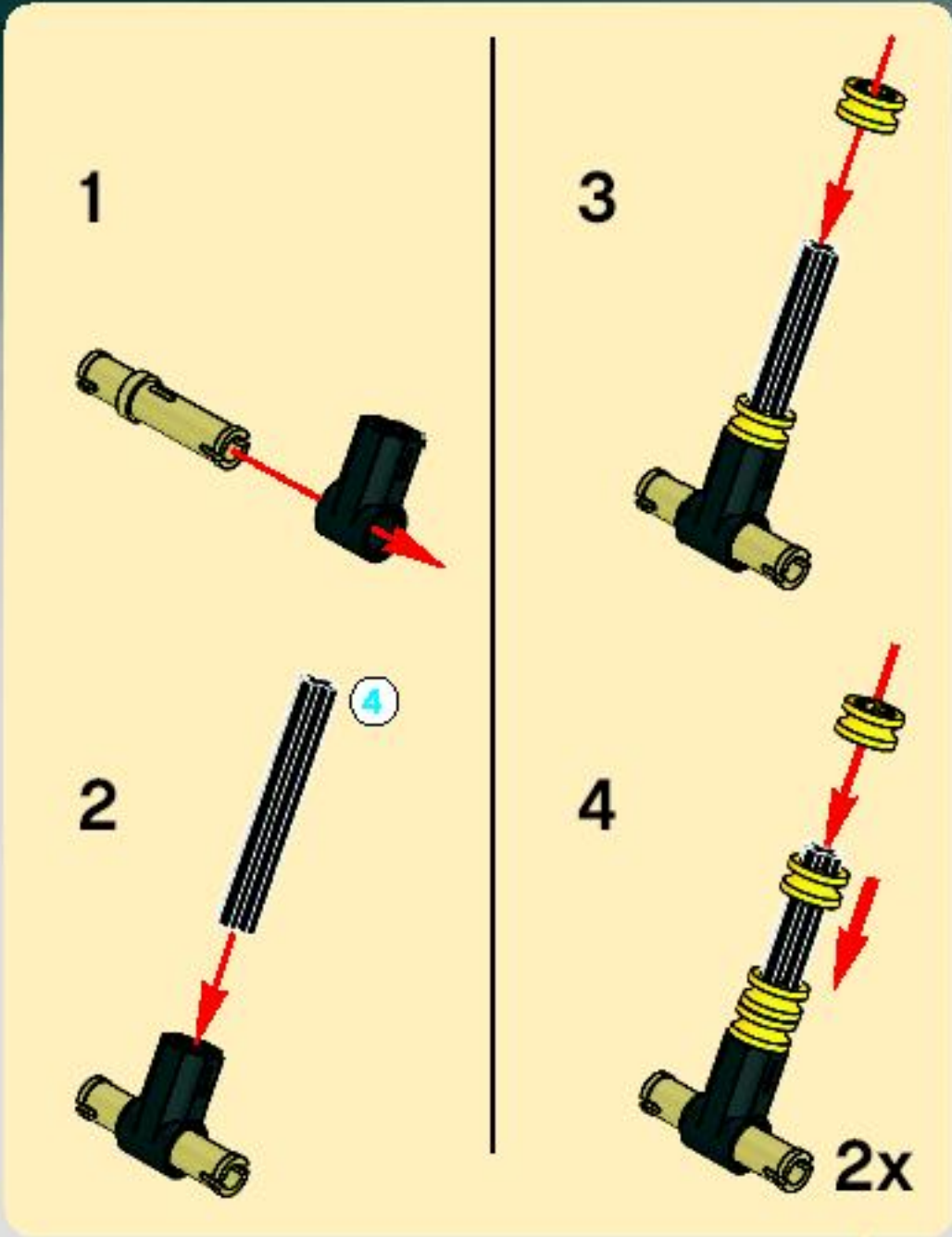



3

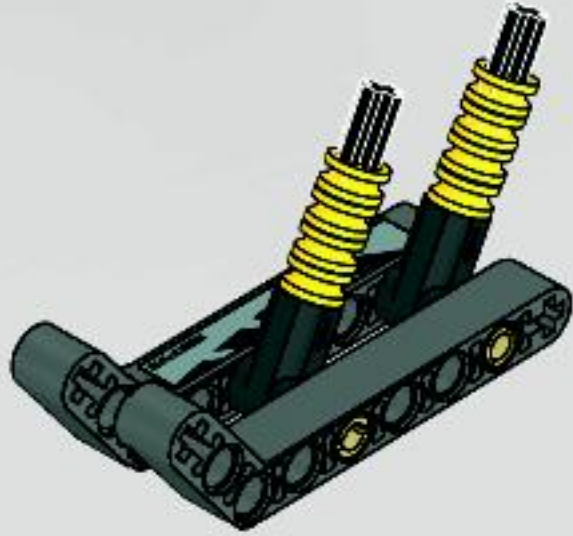

4

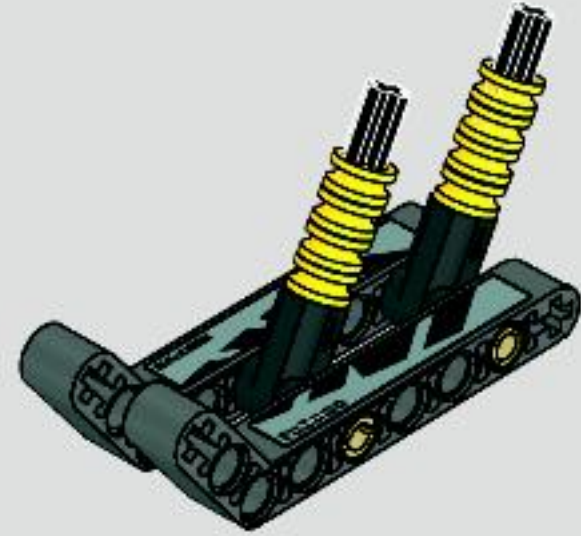

16

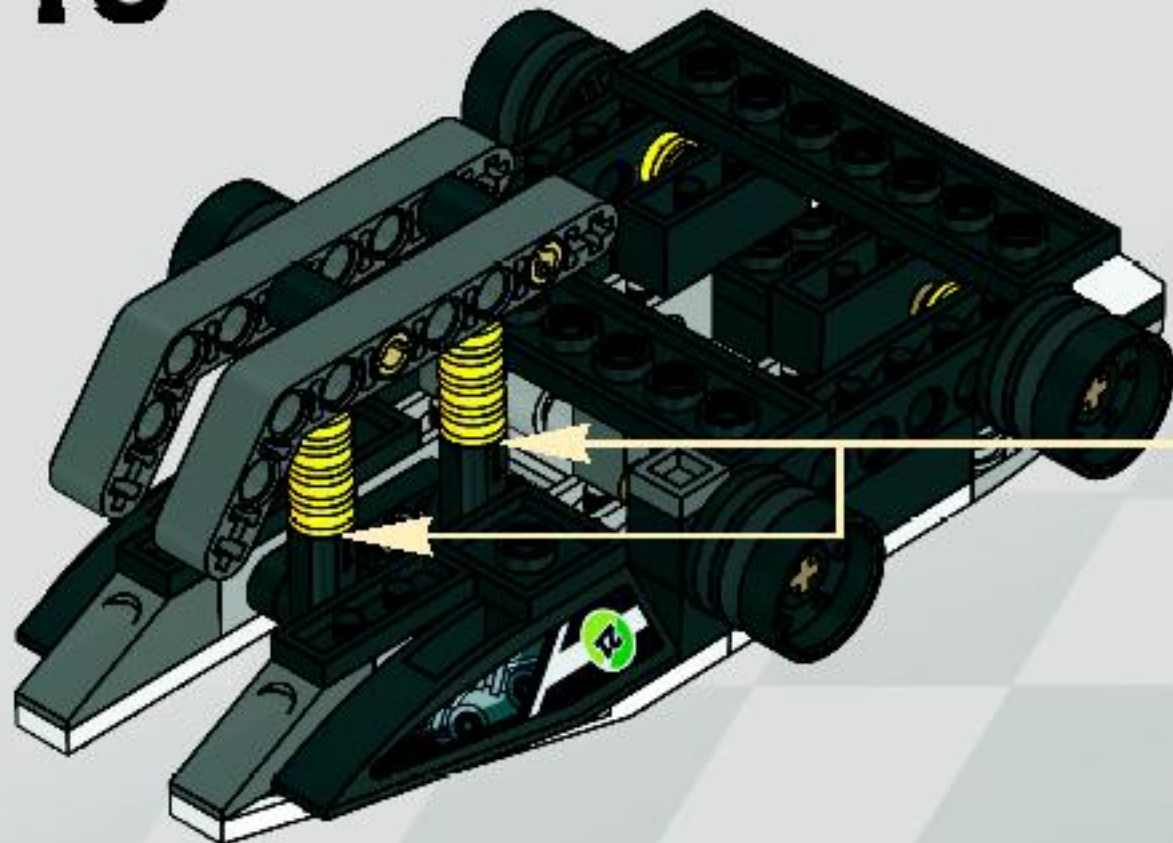



17

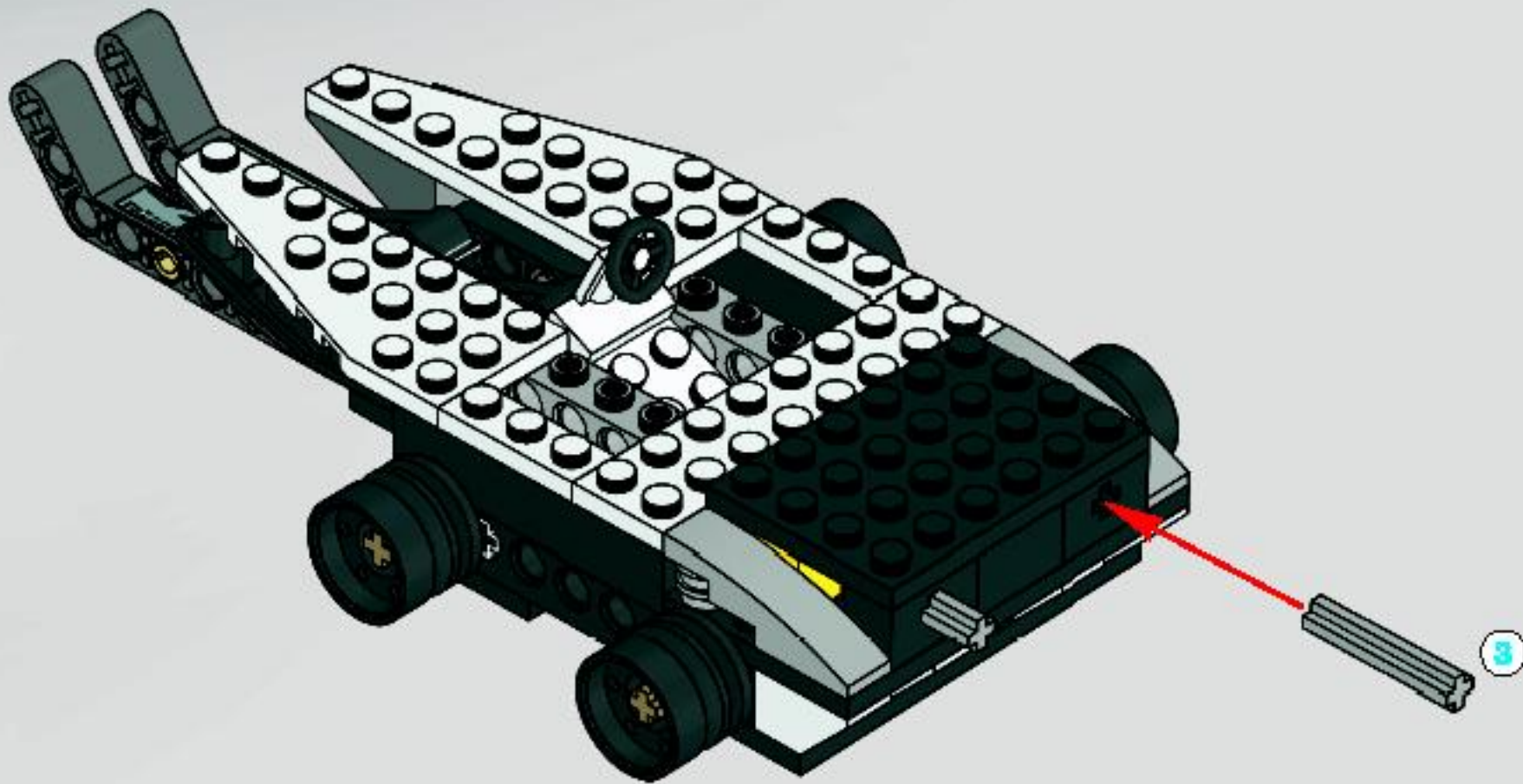



1x



1x



2x

18

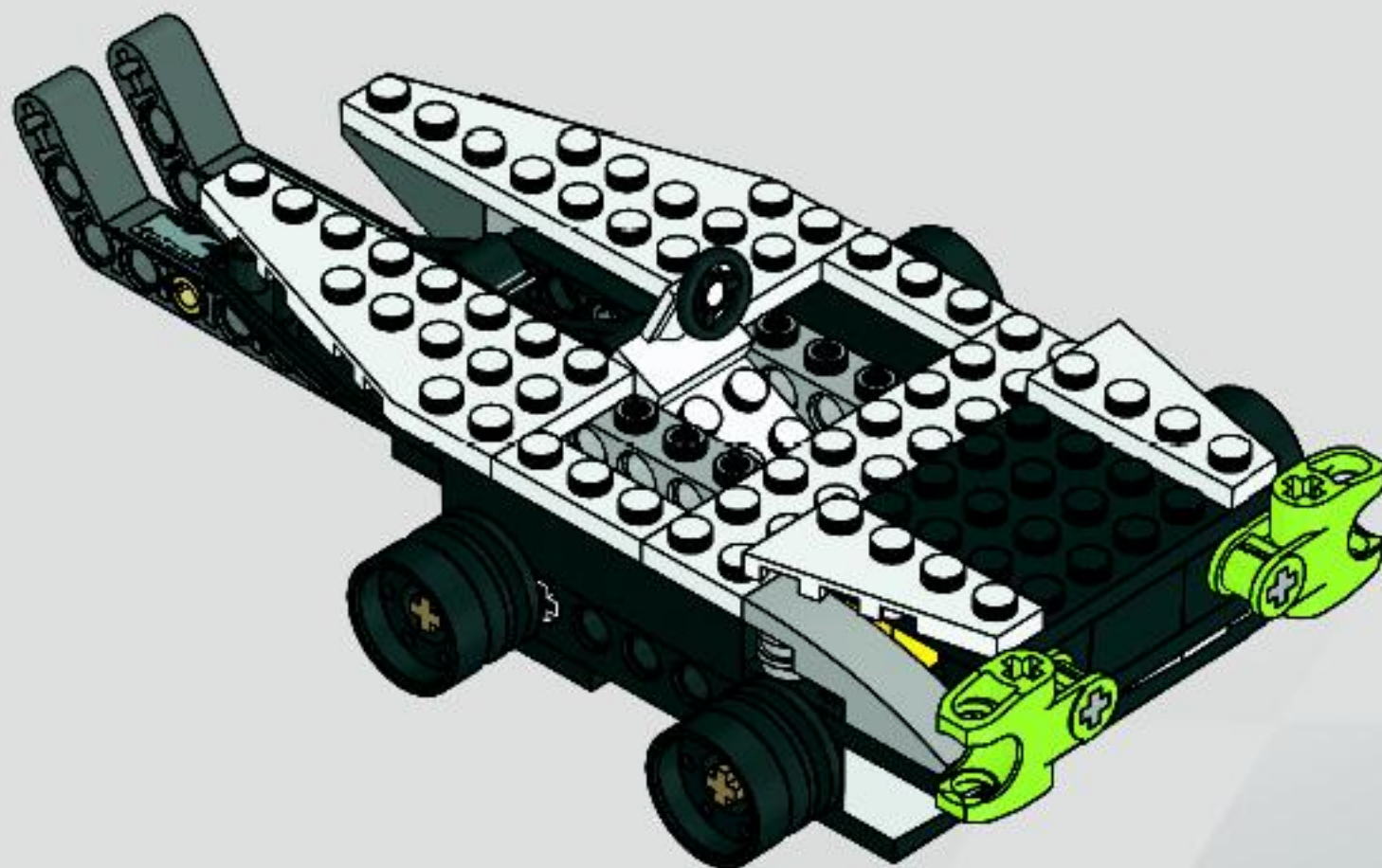

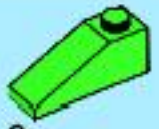

2x



2x



2x

19



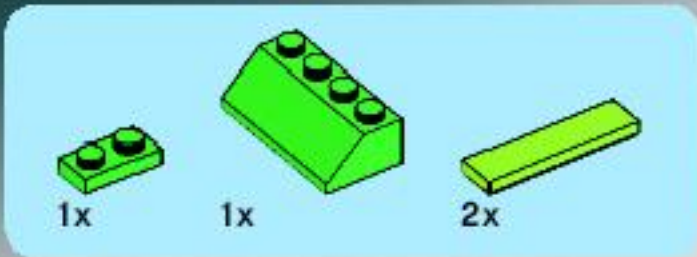

20

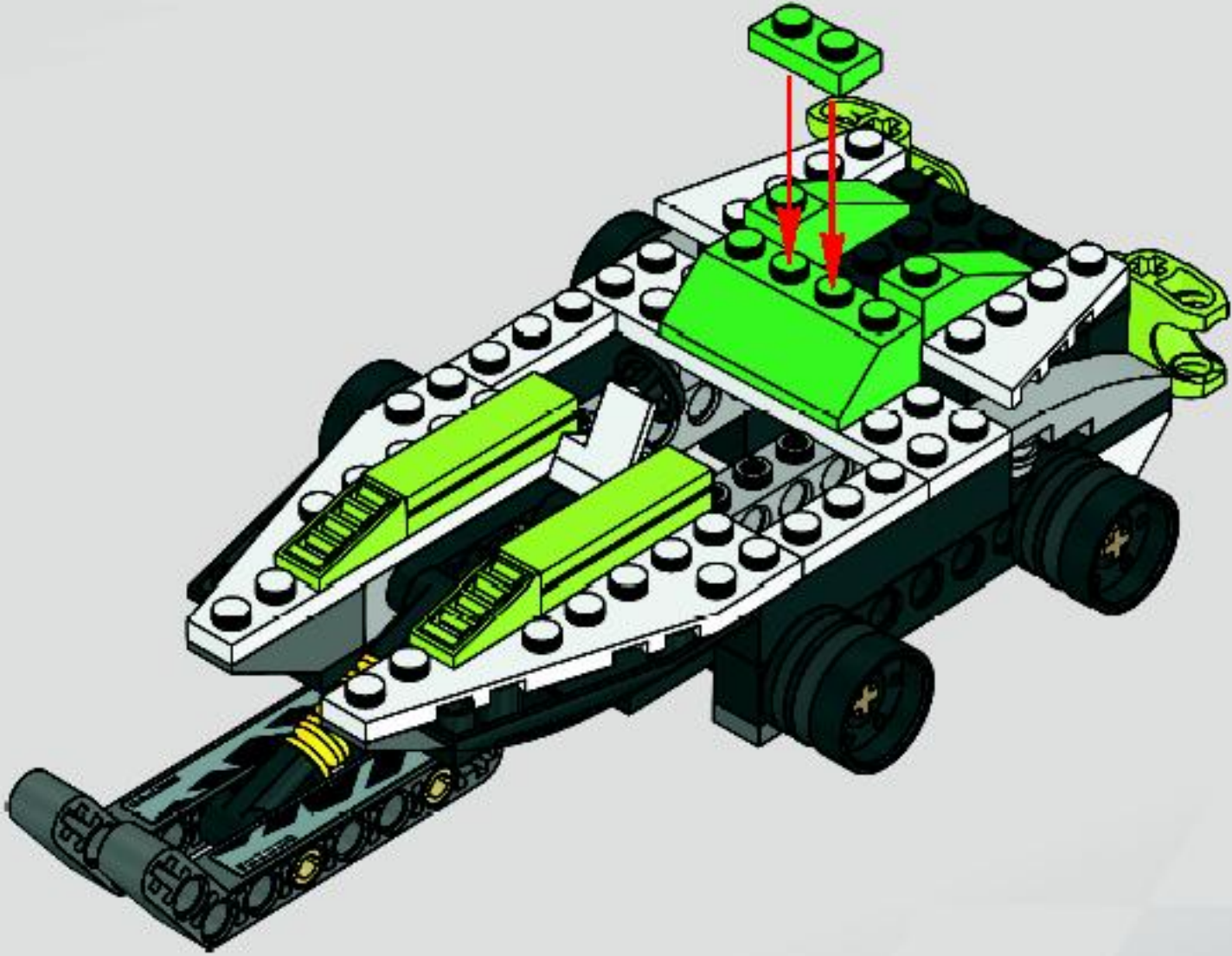



1x

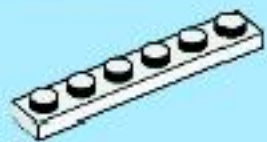

2x

21

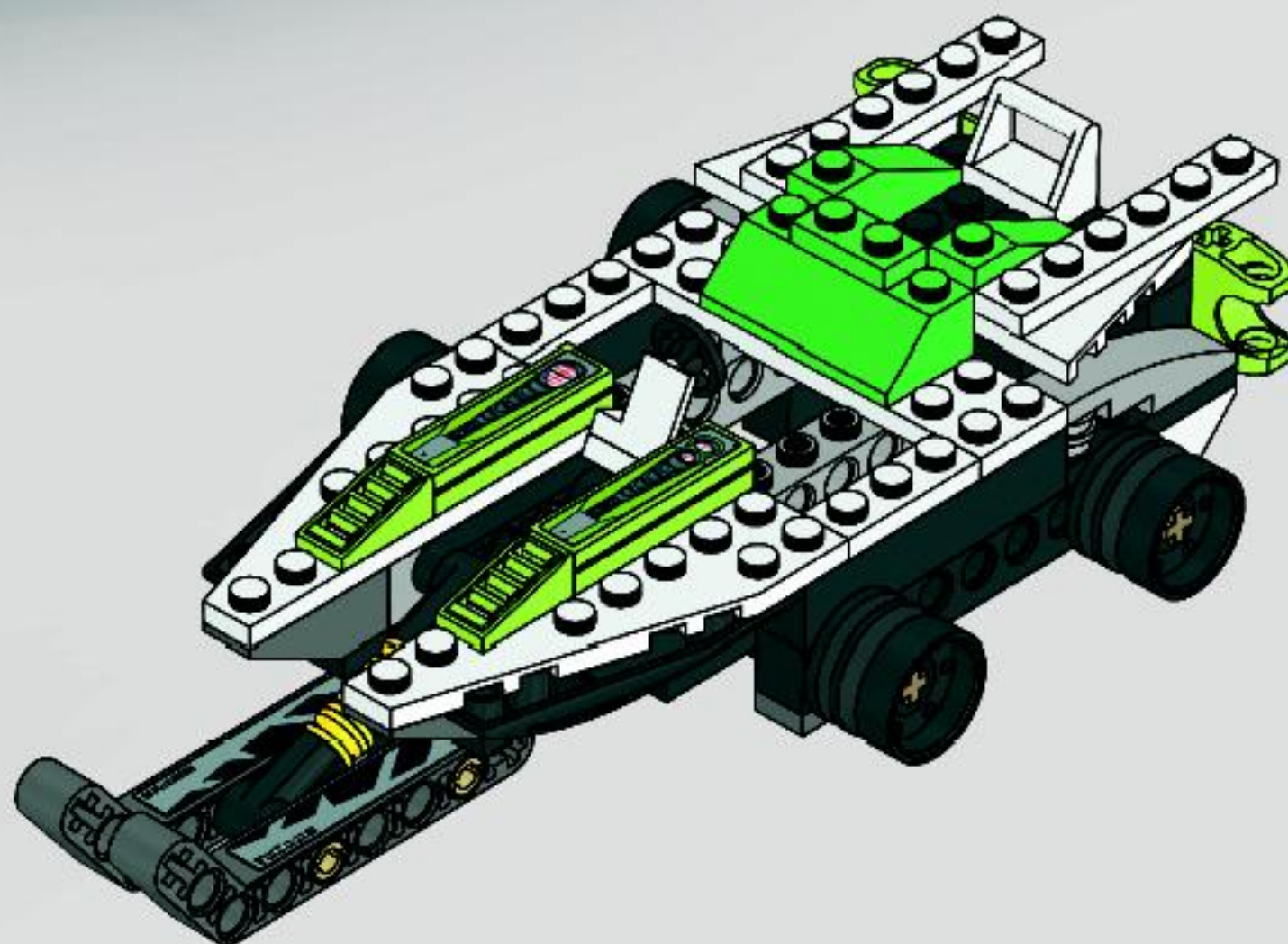

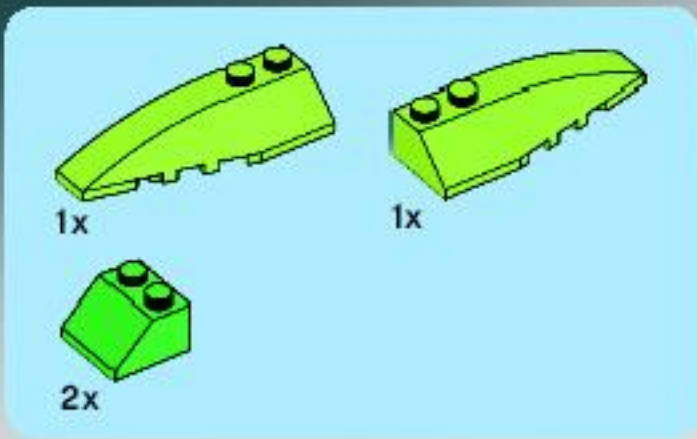

22

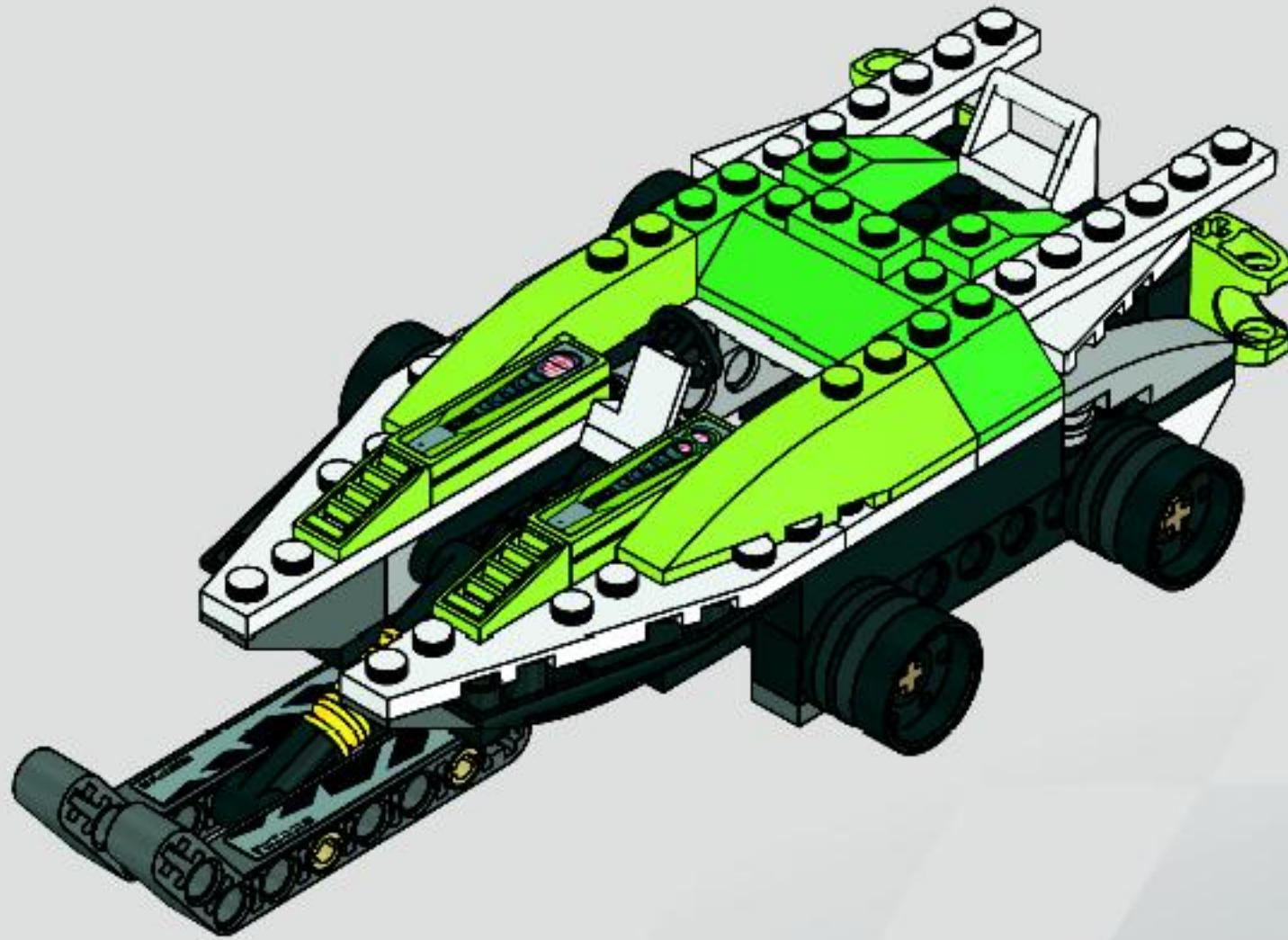



2x

23

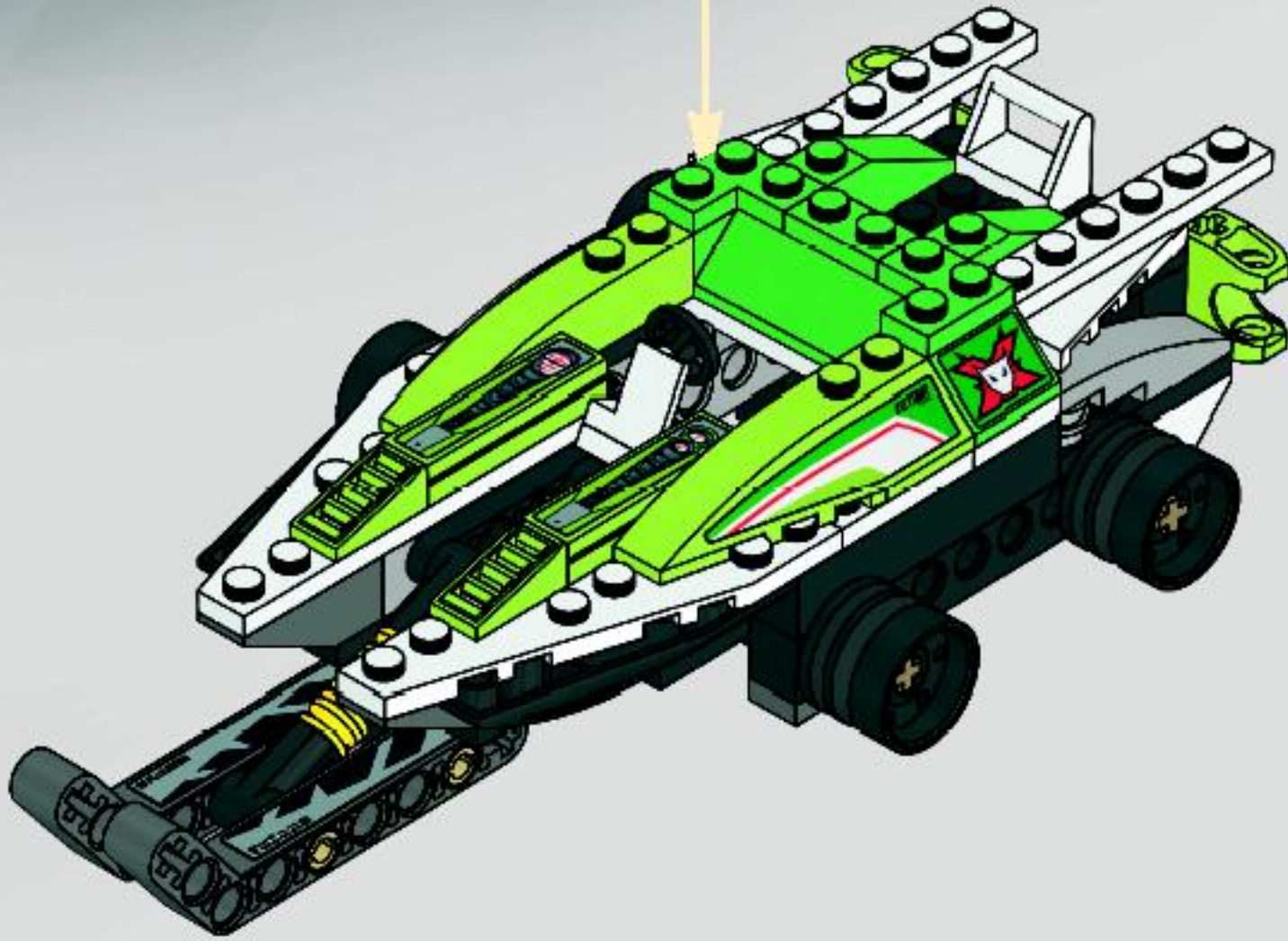

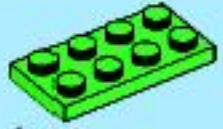

1x



2x

24

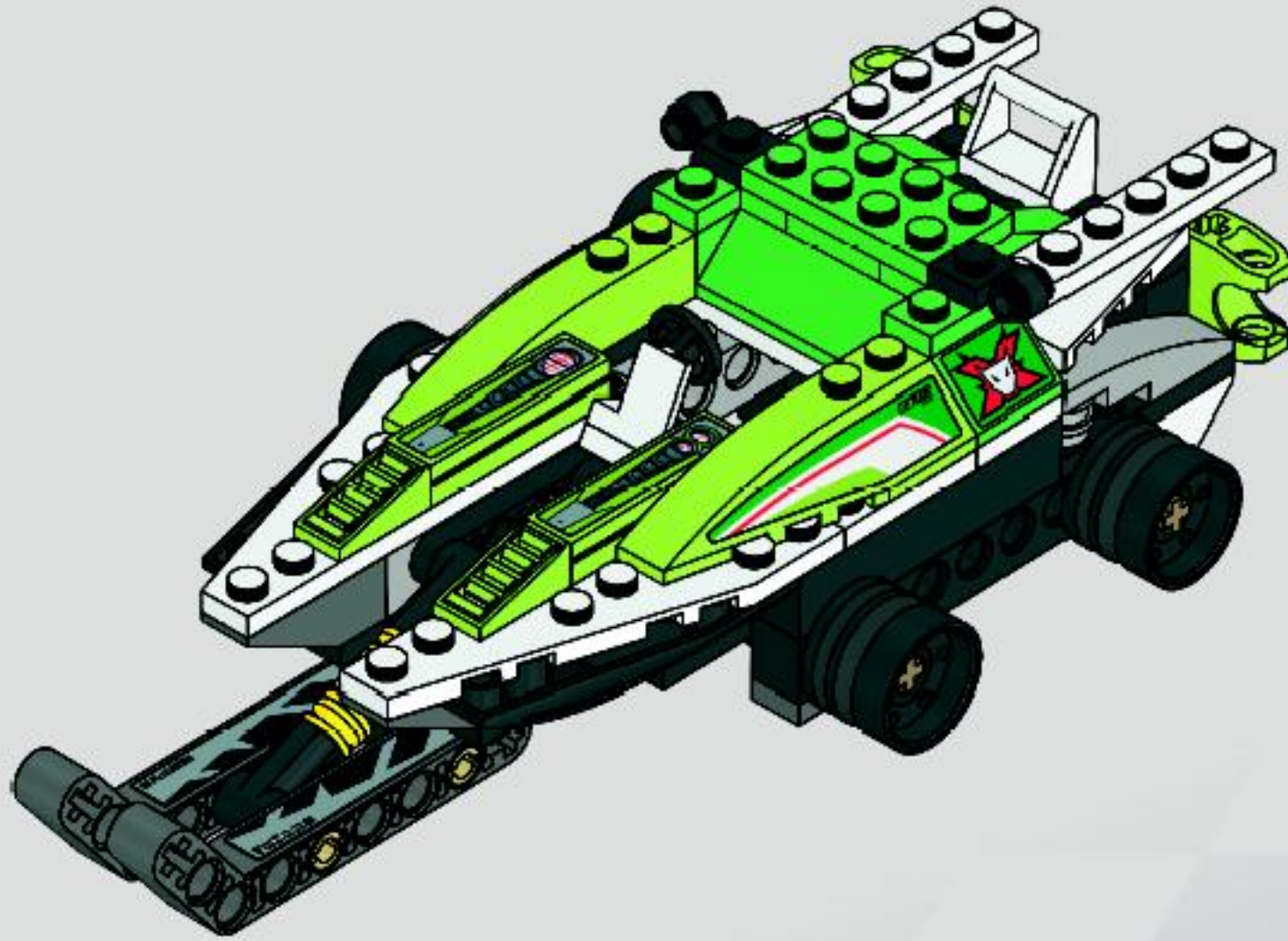



25

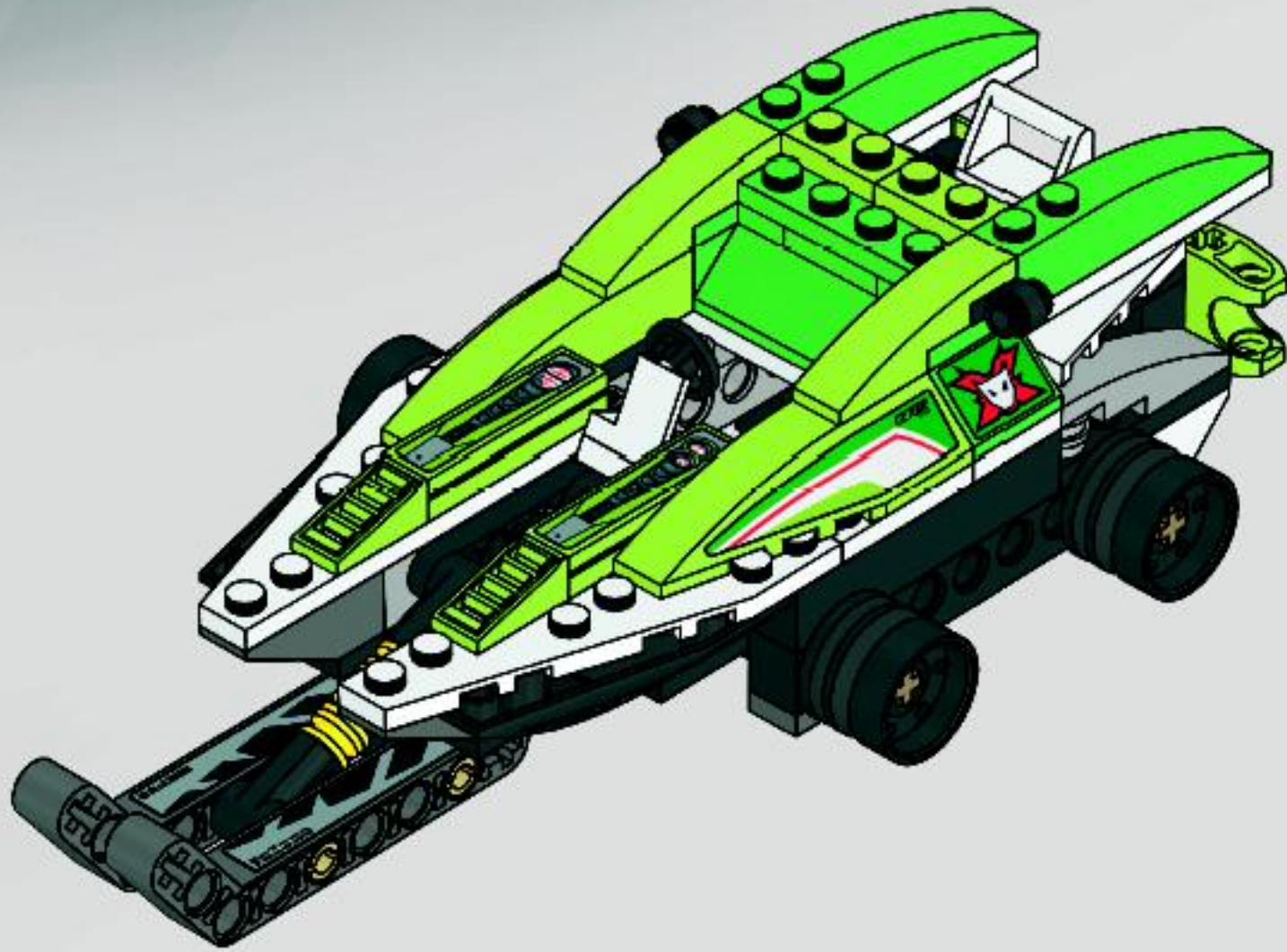



2x

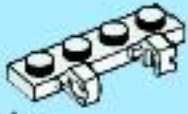

1x

26

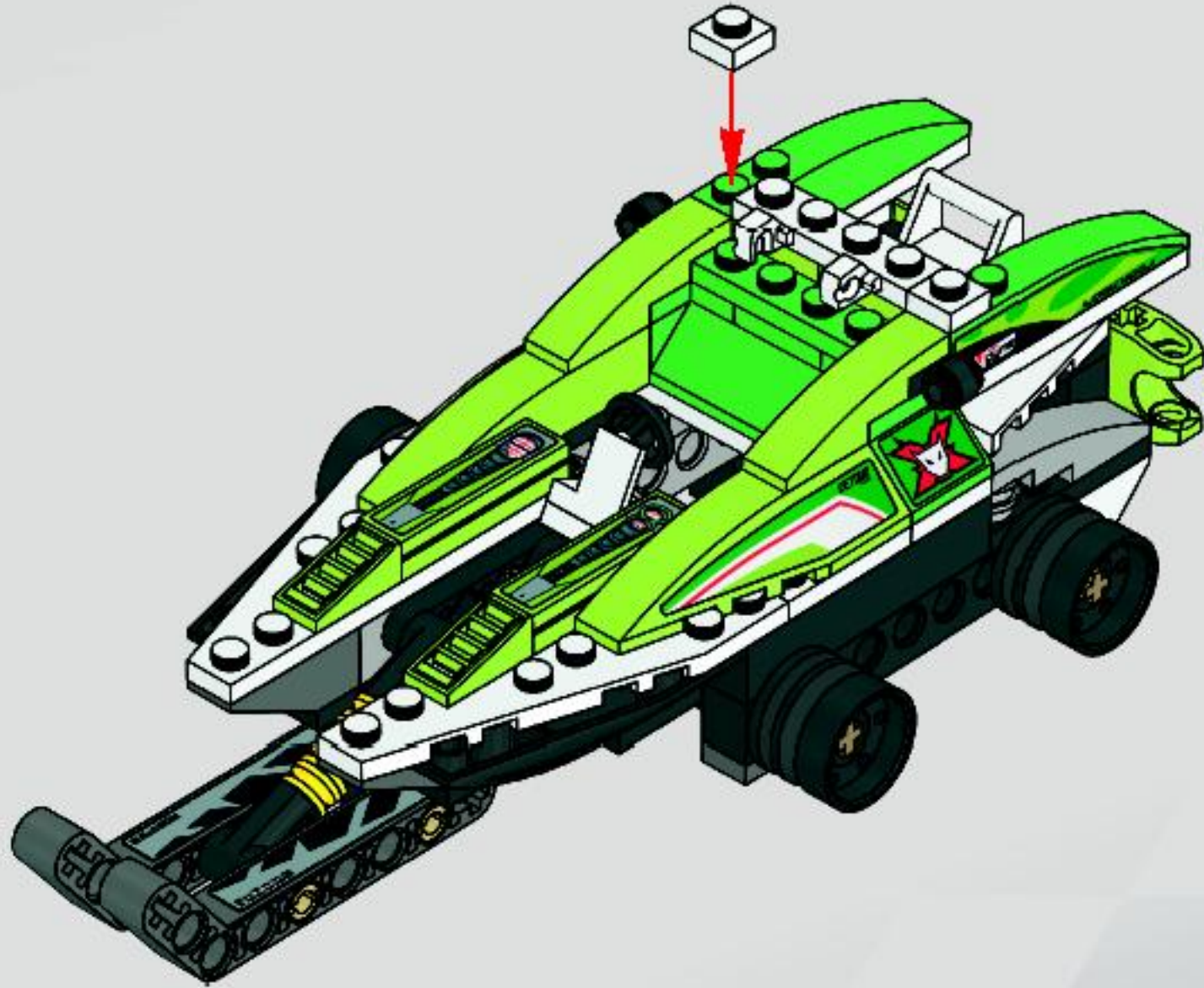



1x

27

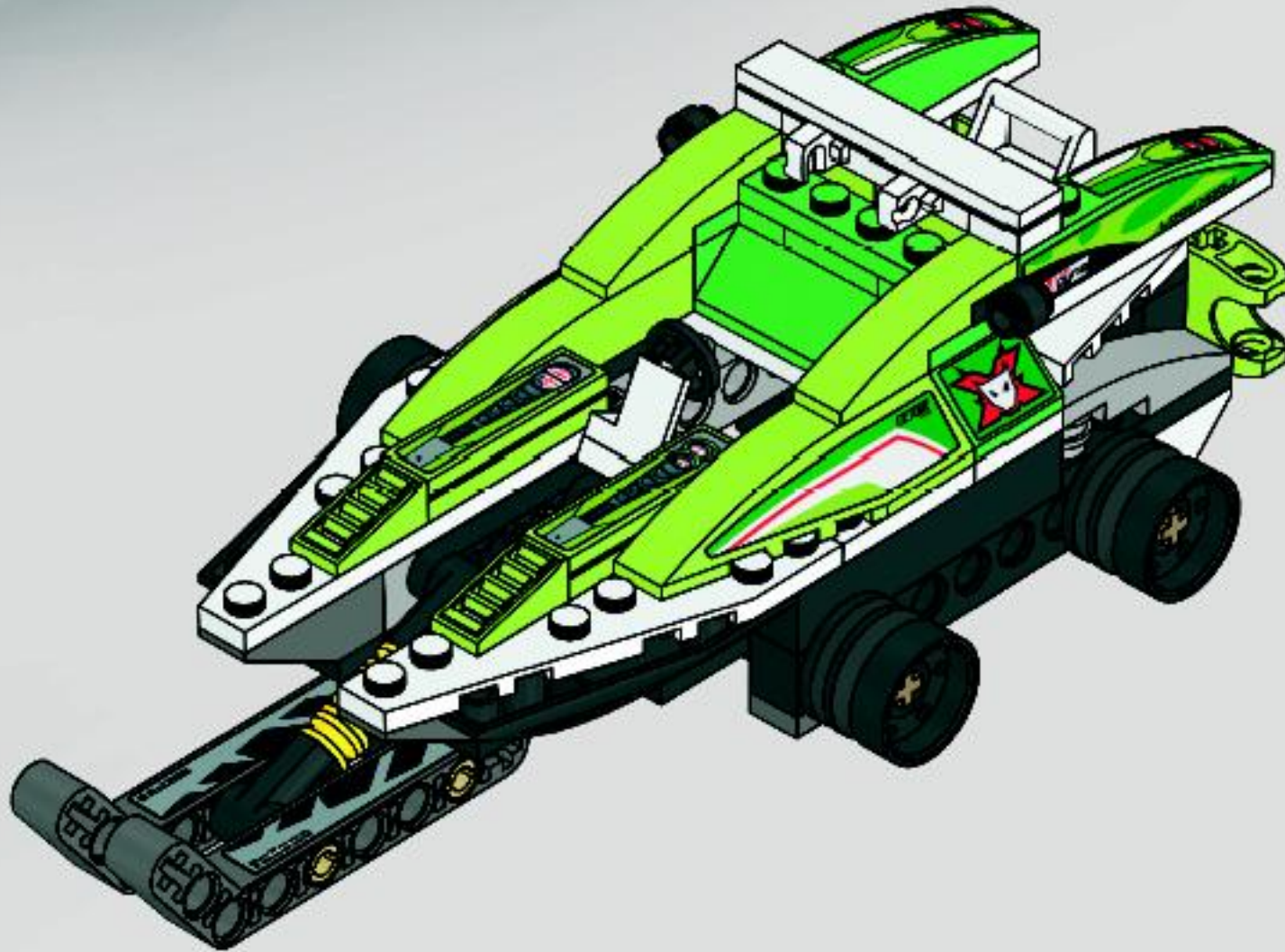

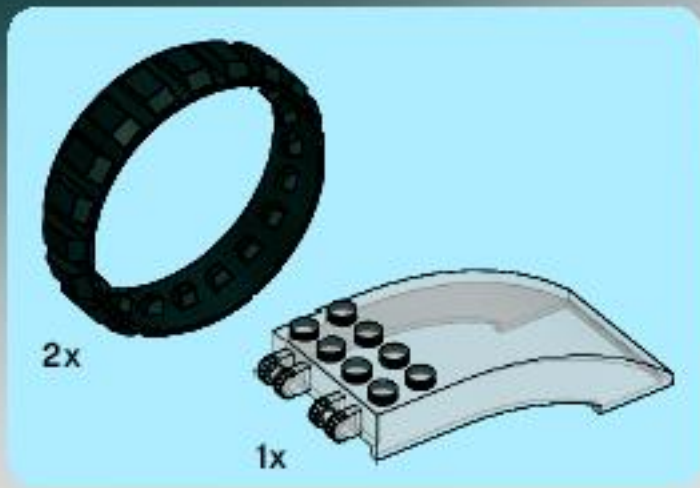

28

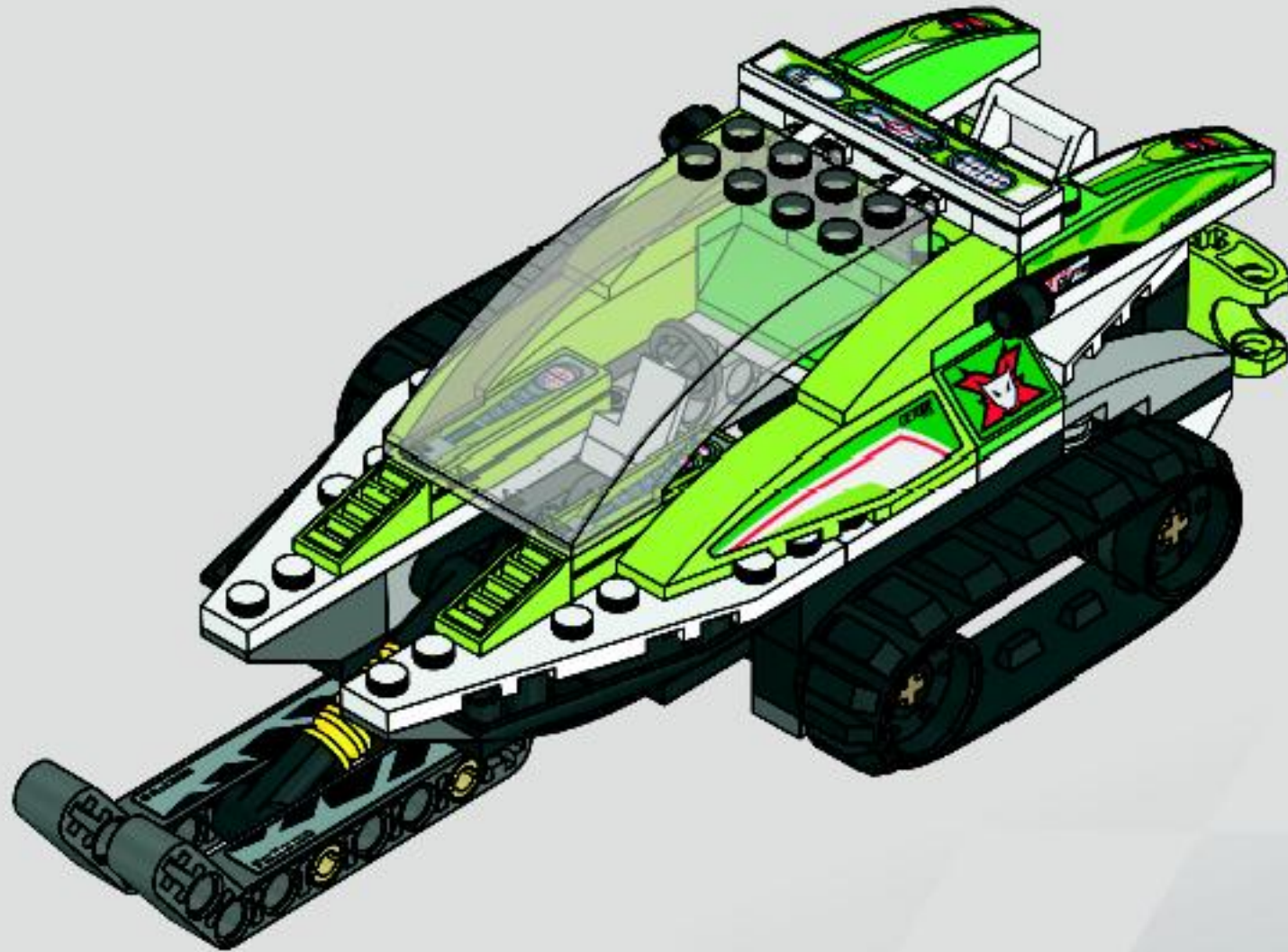

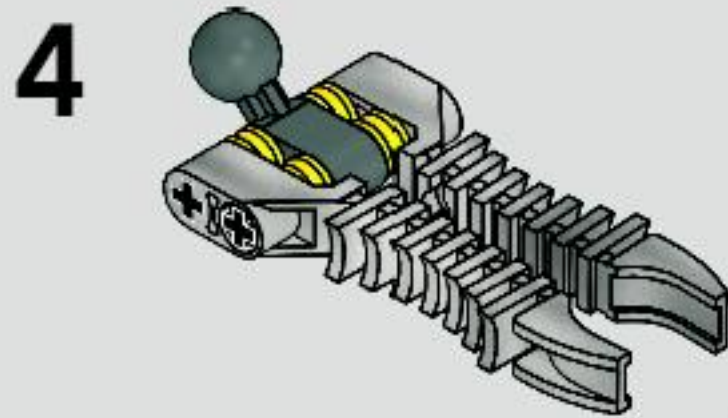
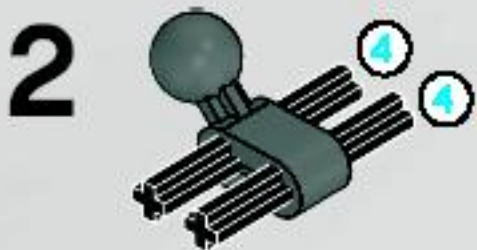
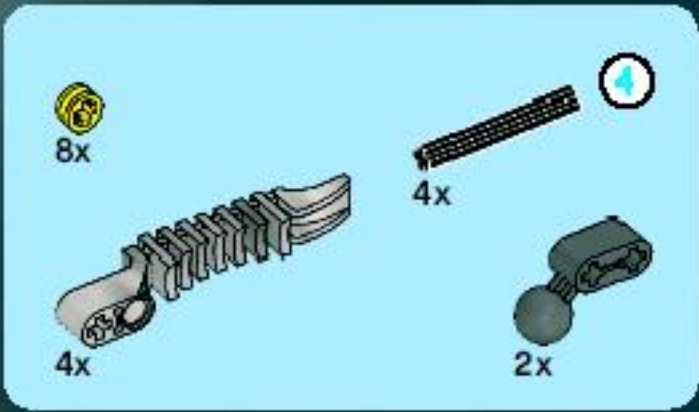

2x

1:1

29

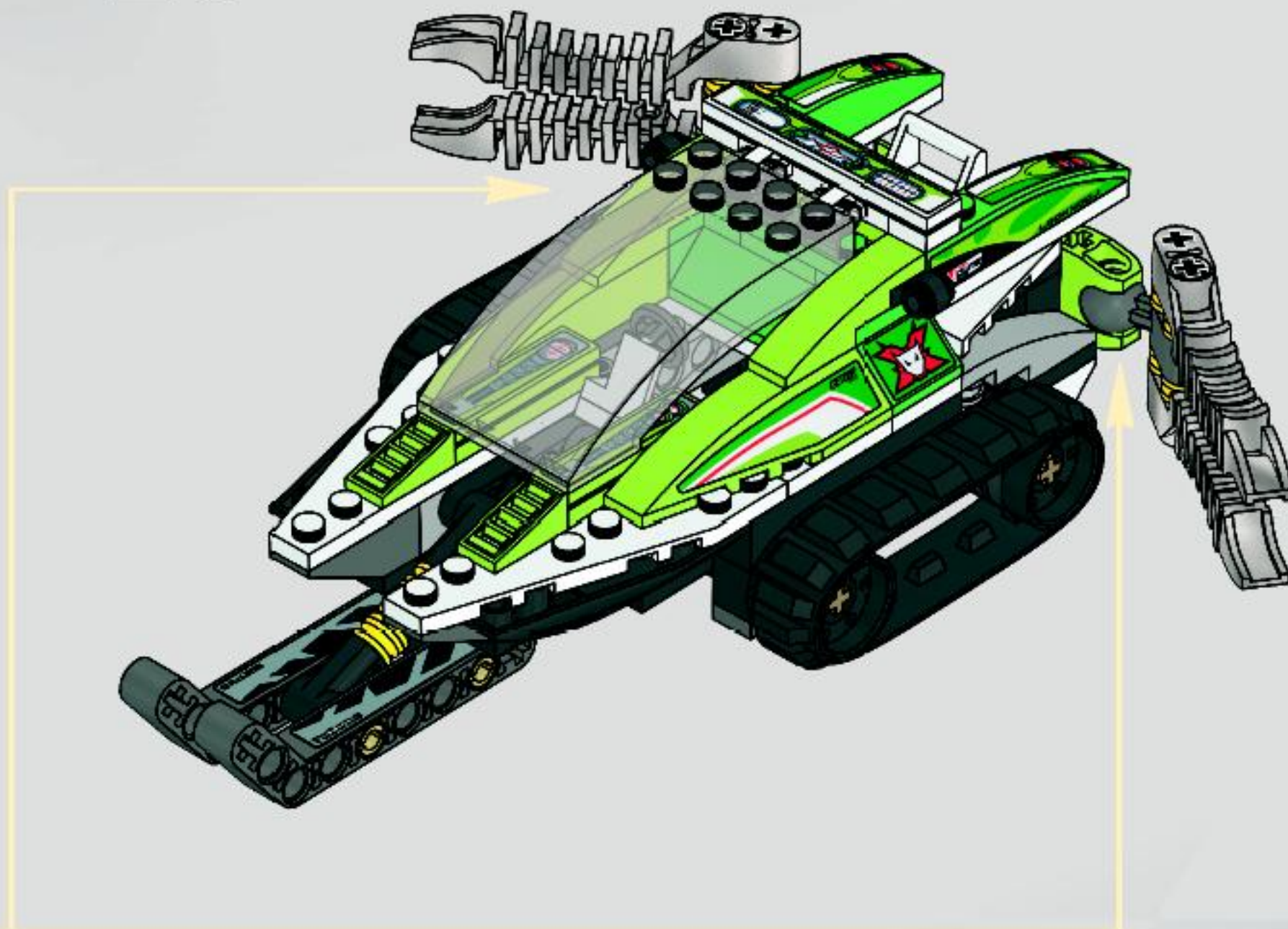



2x

30

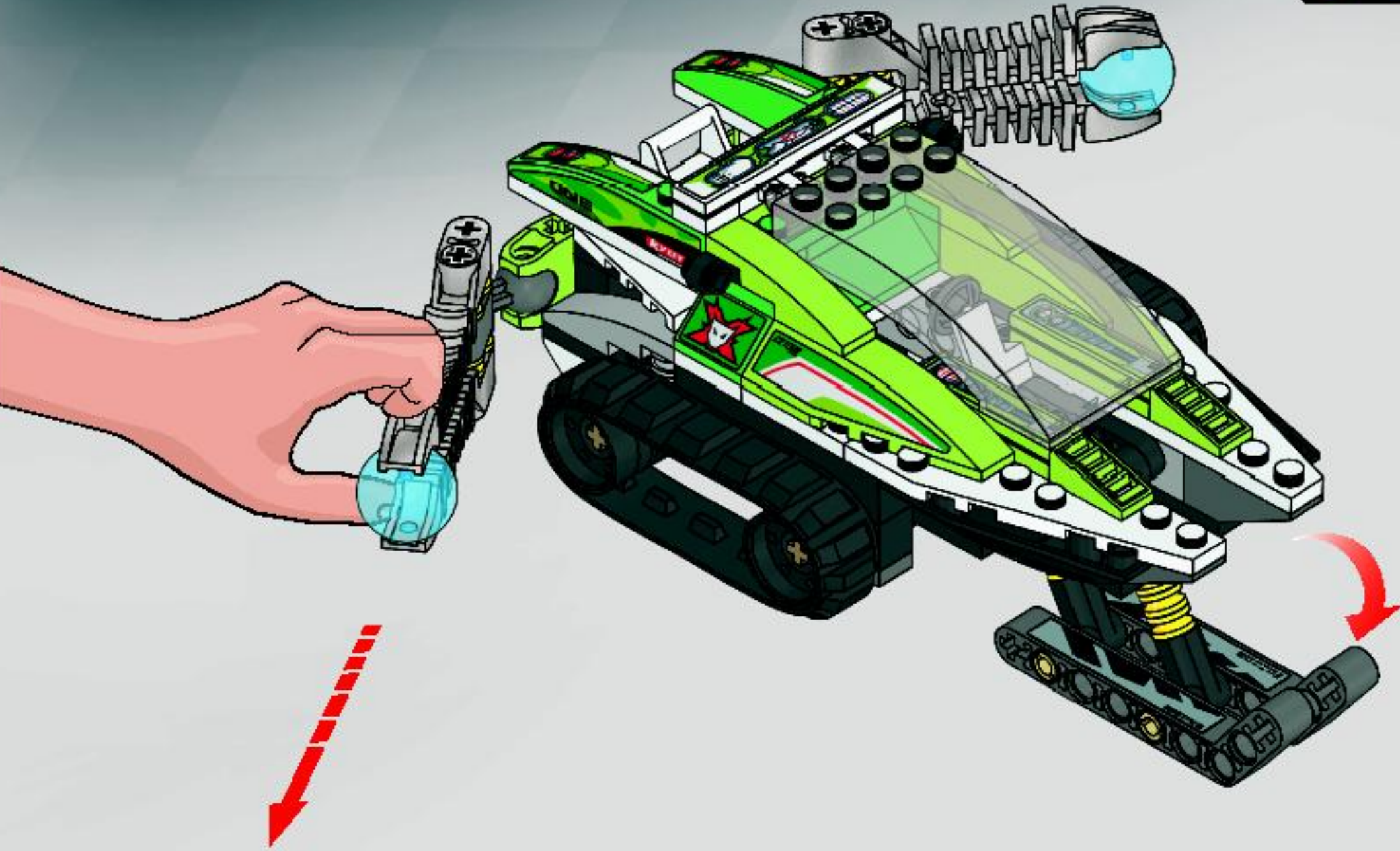

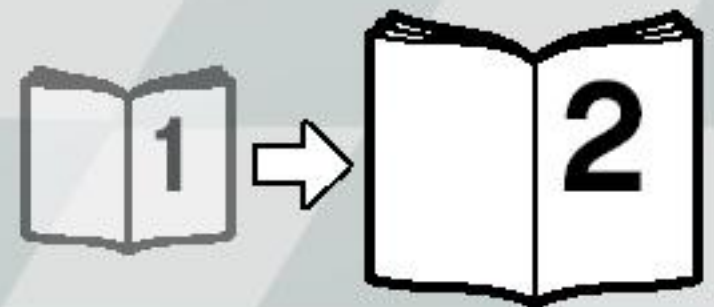
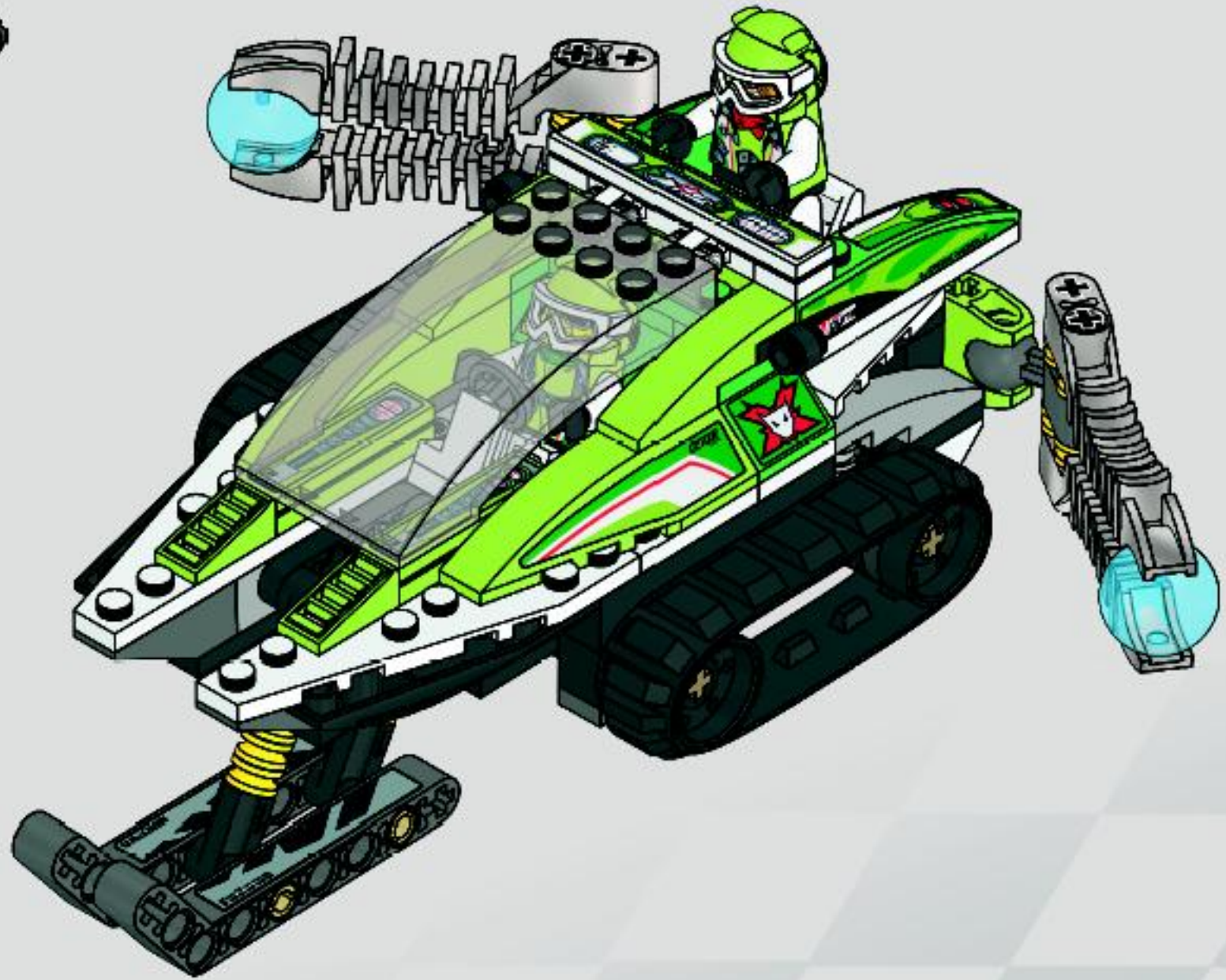

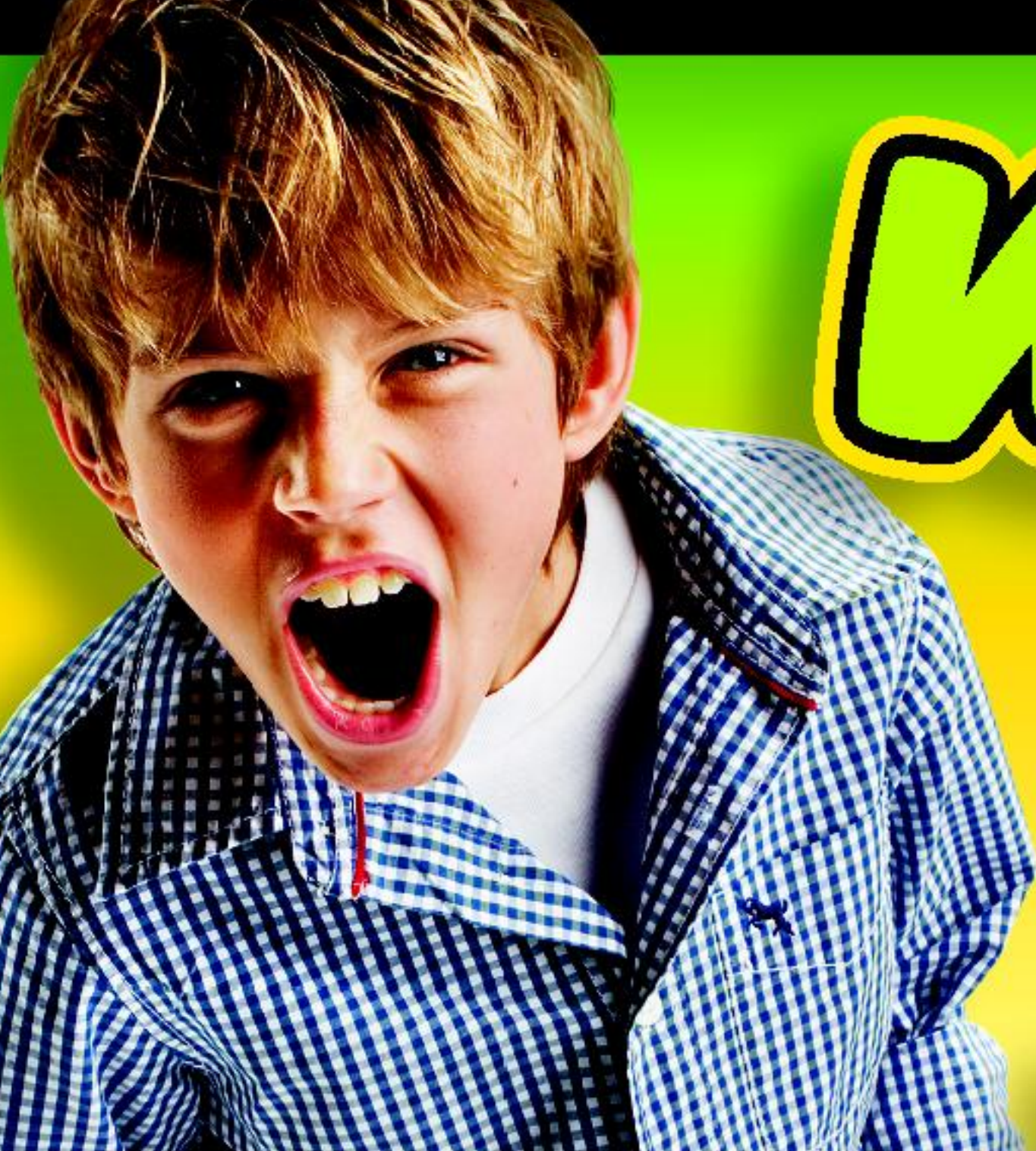

WIN!

Go to www.nielsen.com/LEGO to fill out a survey for a chance to win a cool LEGO® Product.

No purchase necessary.

Open to all residents where not prohibited.



www.nielsen.com/LEGO

GEWINNE! WIN!

Nimm an der Umfrage auf www.nielsen.com/LEGO teil und hab die Chance ein cooles LEGO® Produkt zu gewinnen!

Die Teilnahme am Gewinnspiel führt zu keinerlei Kaufverpflichtungen. Teilnahme in allen nicht ausgeschlossenen Ländern möglich.

Ga naar www.nielsen.com/LEGO, vul een enquêteformulier in en maak kans op een cool LEGO® product.

Geen aankoopverplichting. Iedereen mag deelnemen, uitgezonderd ingezetenden van landen waar een enquêteverbod geldt.

GAGNE! 当てよう!

Visite www.nielsen.com/LEGO pour répondre à un questionnaire et avoir une chance de gagner un produit LEGO® très cool!

Aucune obligation d'achat. Ouvert à tous les résidents des pays autorisés.

www.nielsen.com/LEGOにアクセスして、アンケートにご記入ください。当選者にはレゴ製品を差し上げます。

お買い上げの必要はありません。禁止されていない限り、すべての年齢層にご利用いただけます。



World Racers



8863



2

5



1x



1x



1x



1x



1x

2

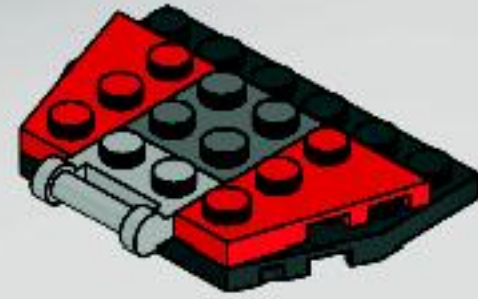

1x



1x

3

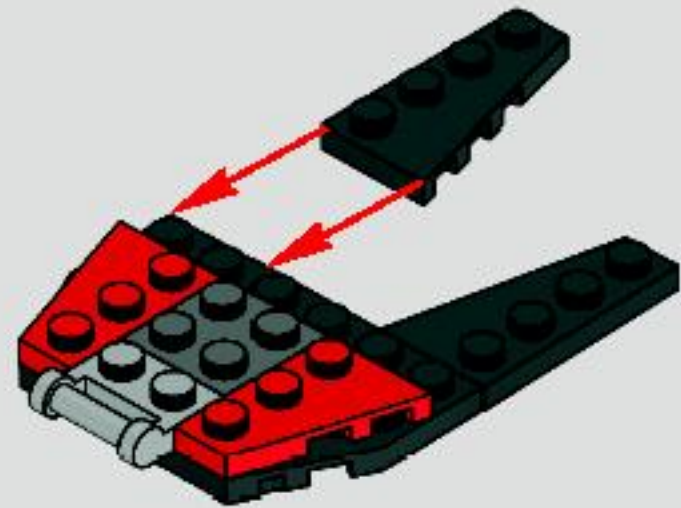

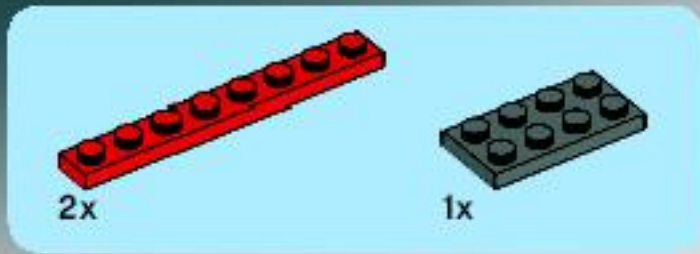

4

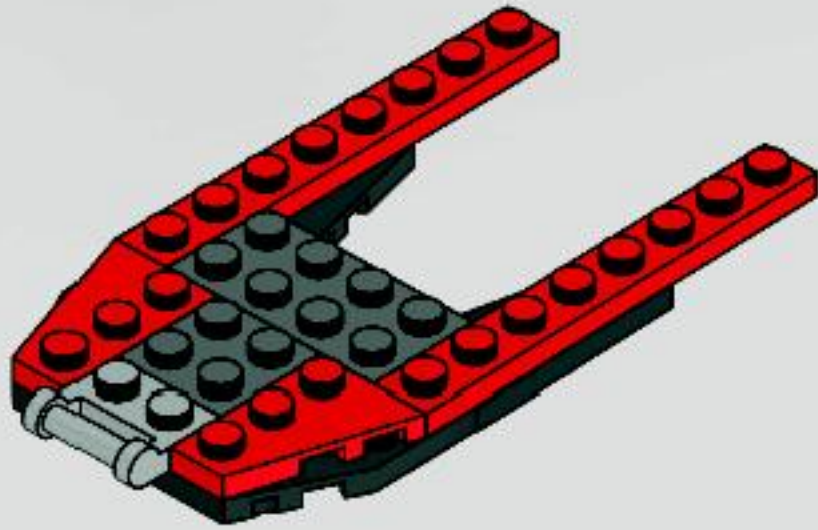

6

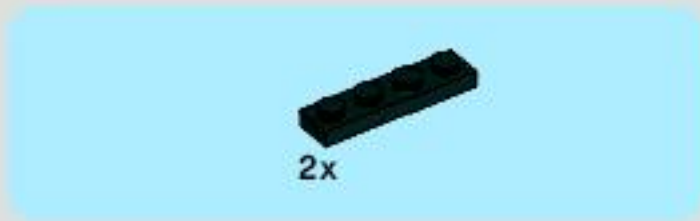
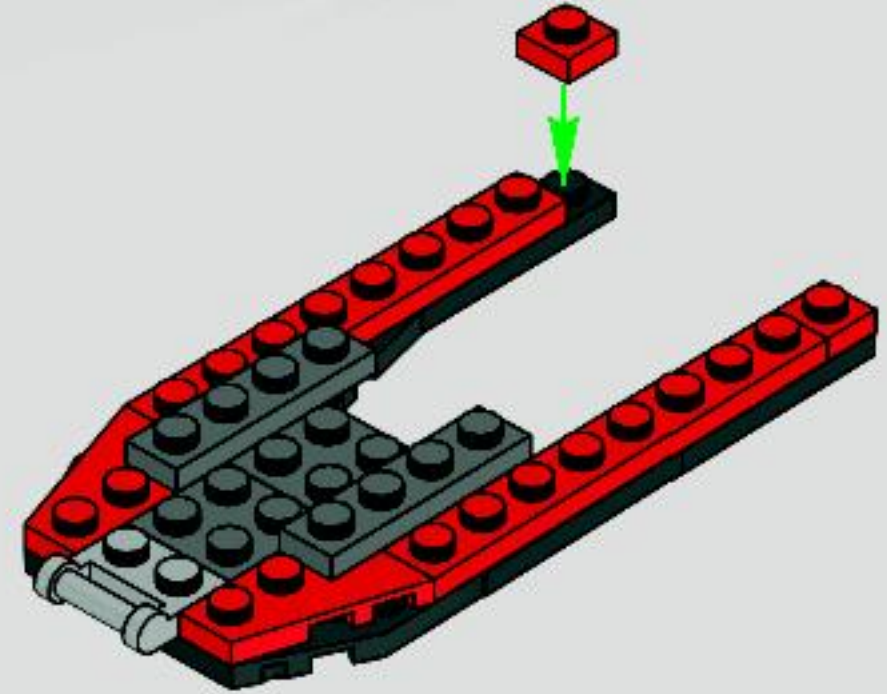

5

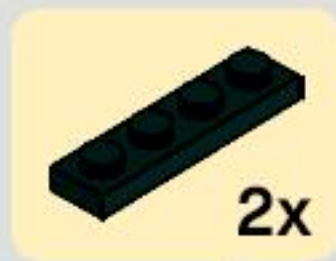
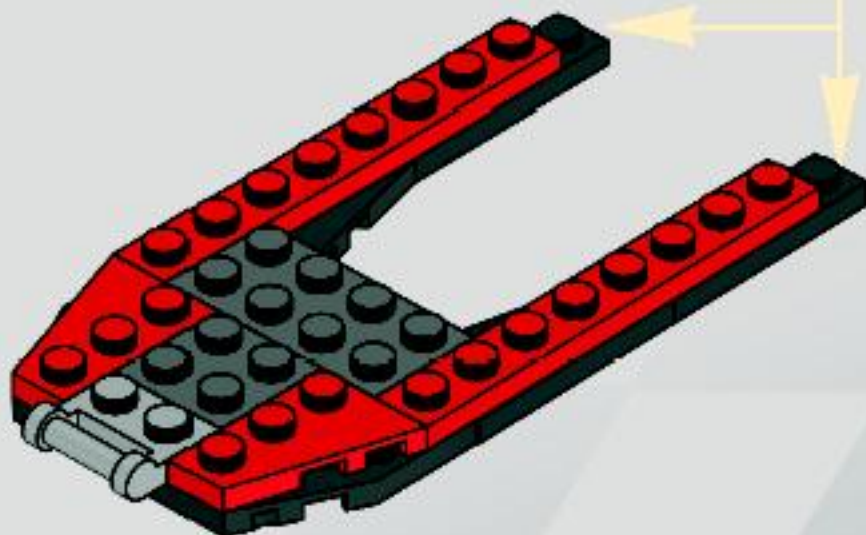

7

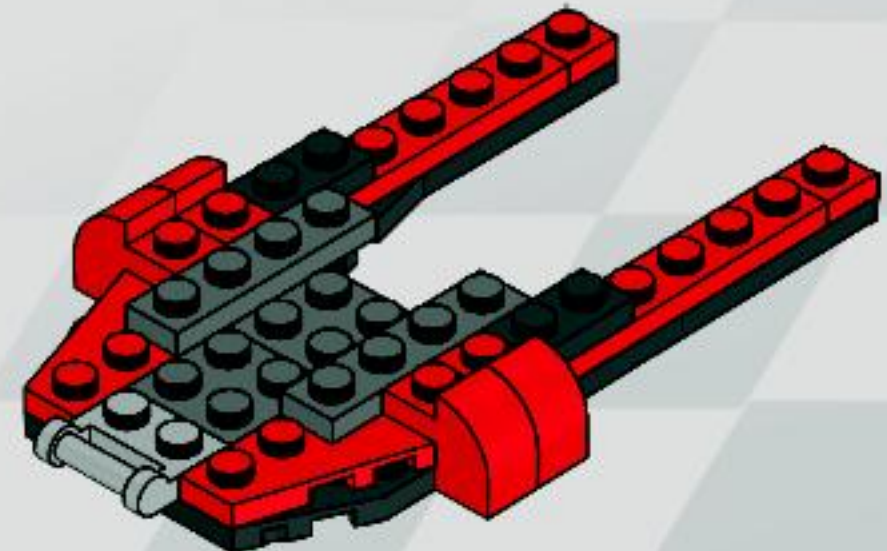

2x  4x 

8

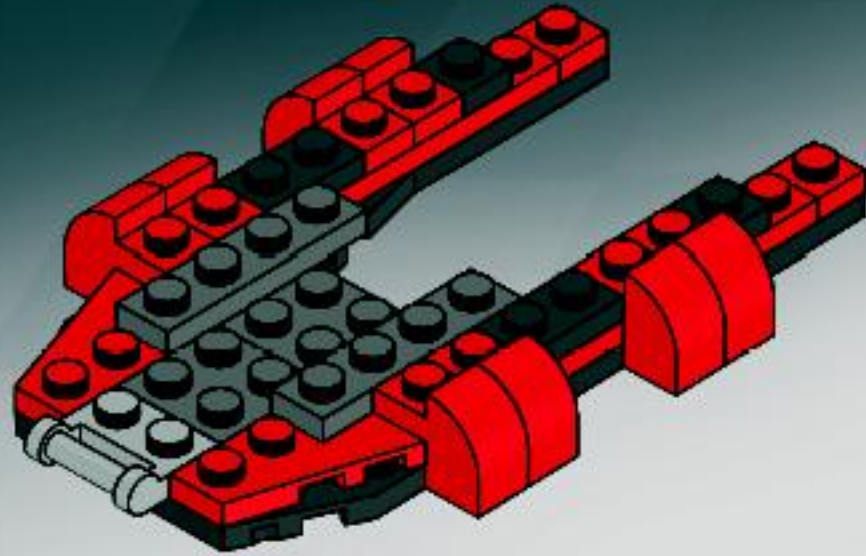

2x  2x 

9

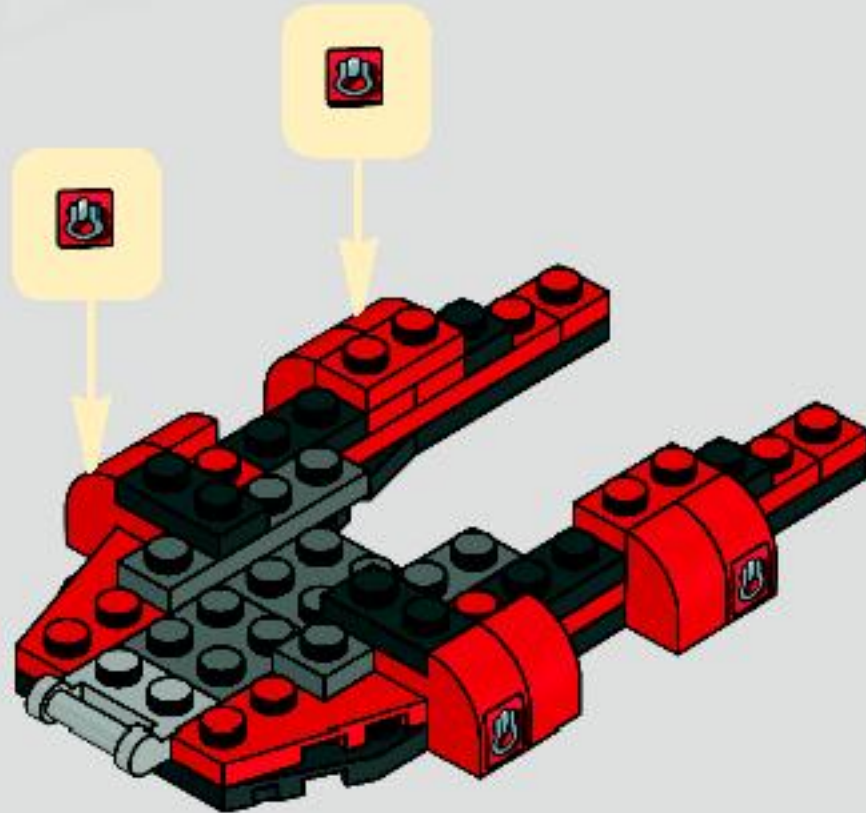

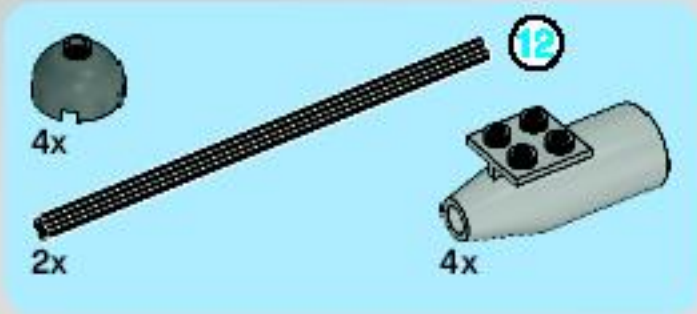
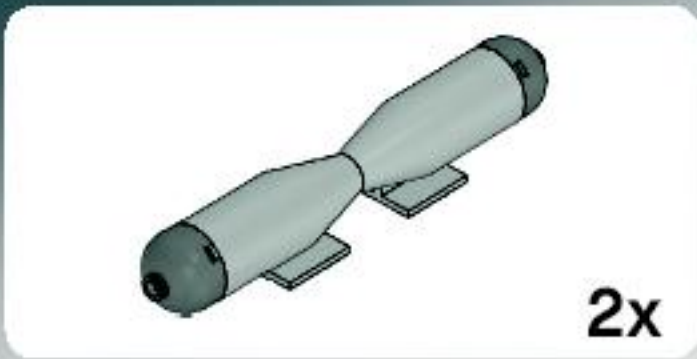

10

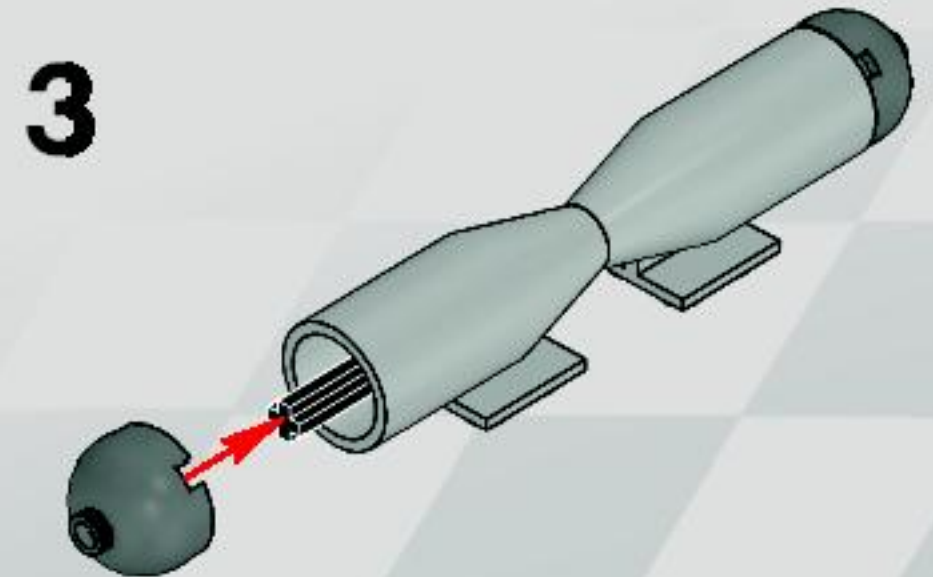
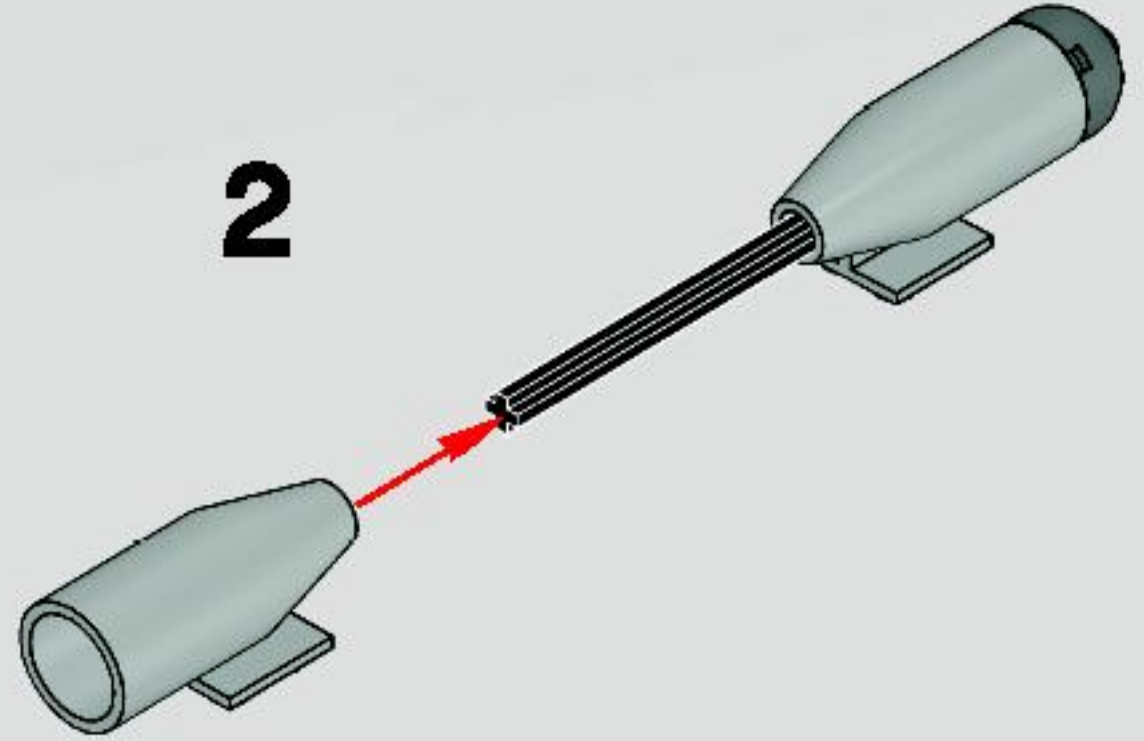
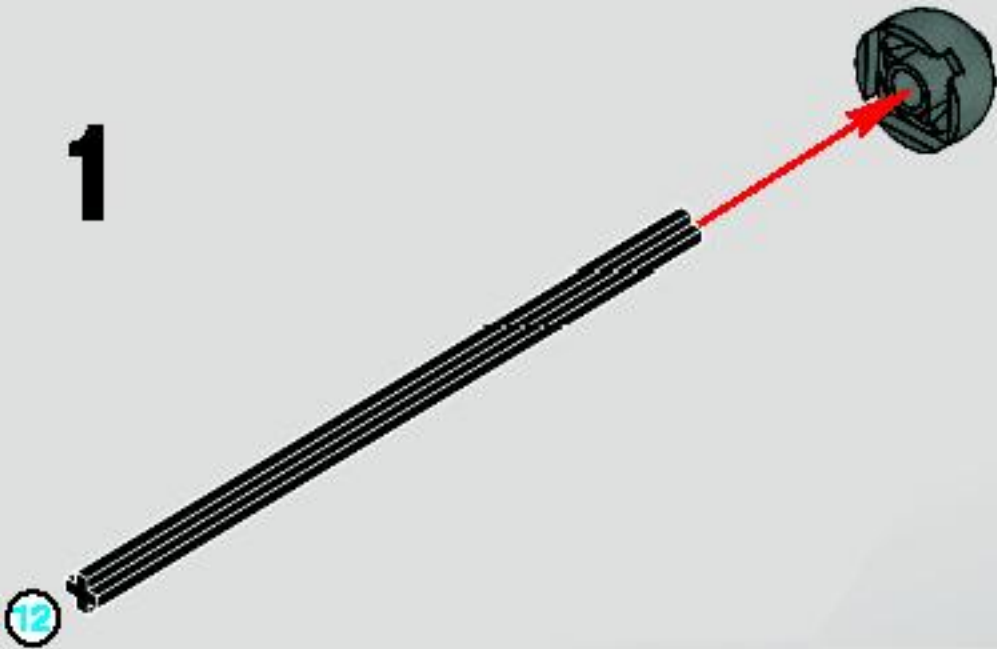

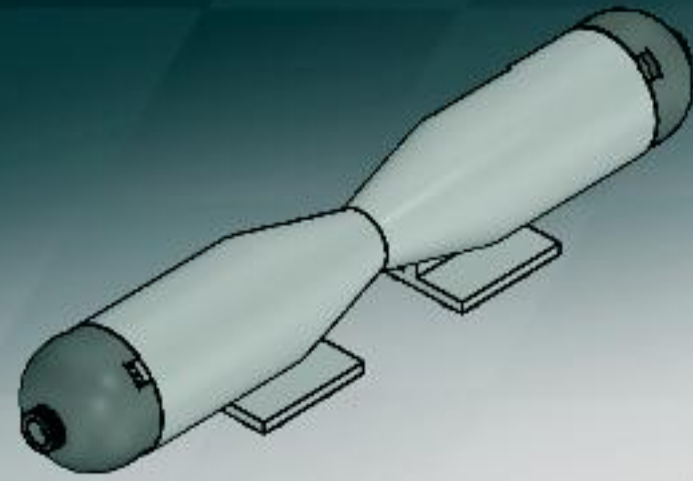

2x

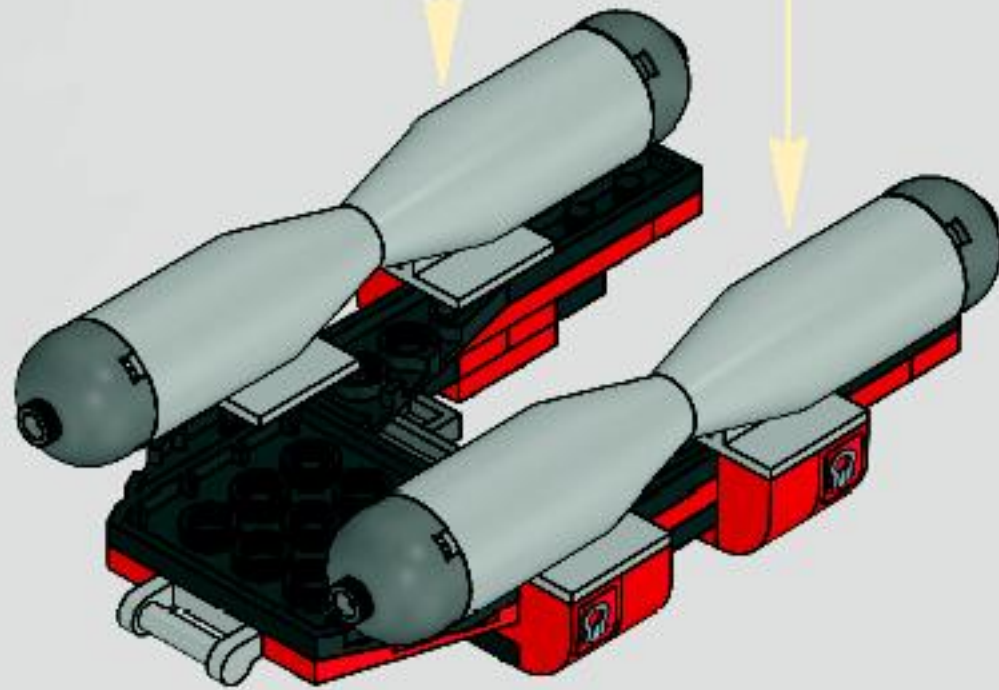

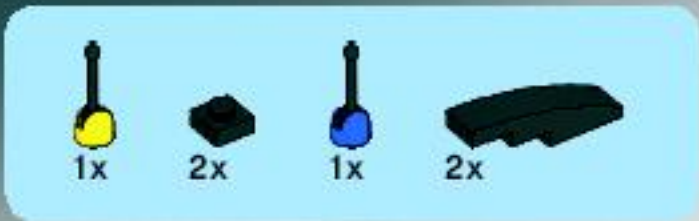

11

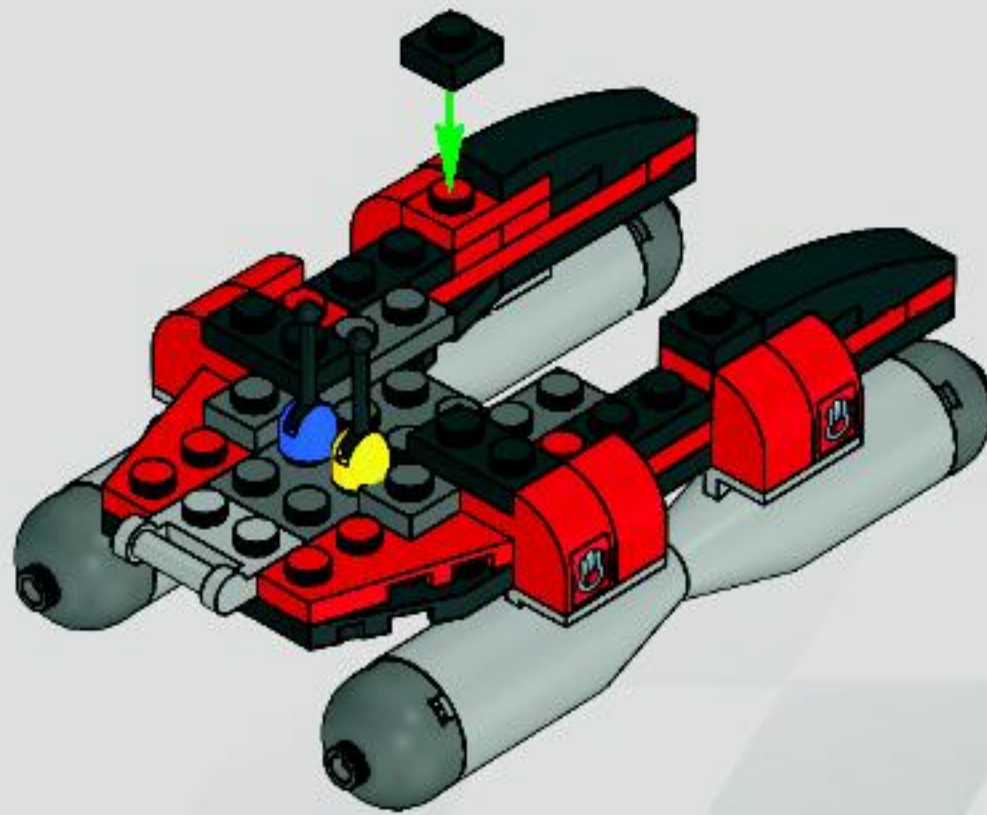



1x



2x

12

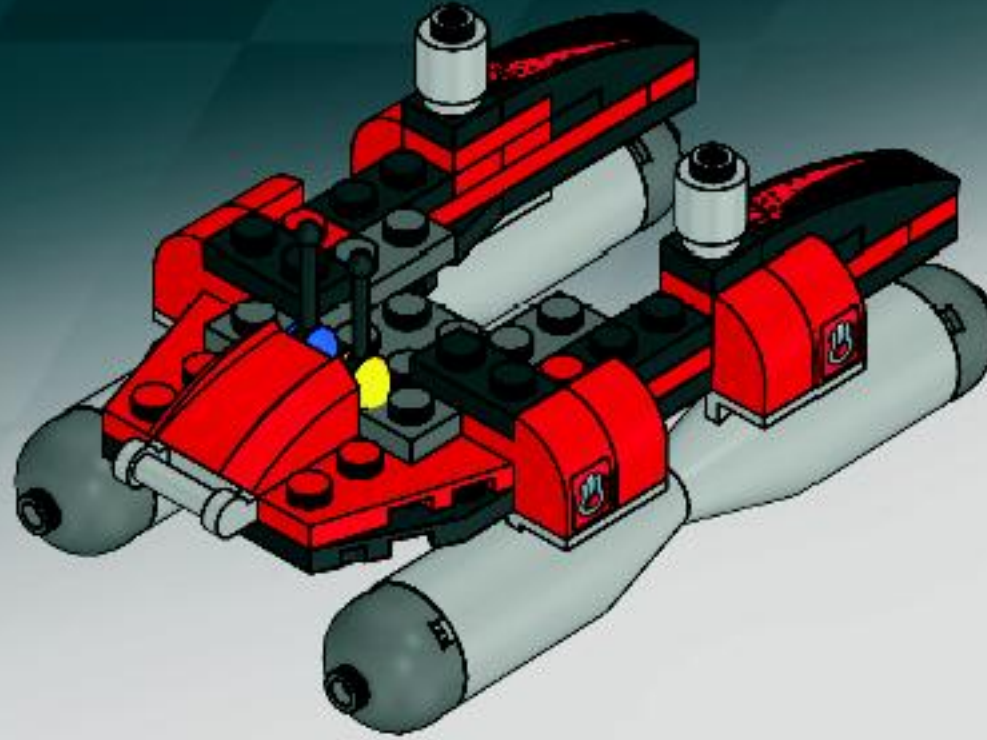

1x

13

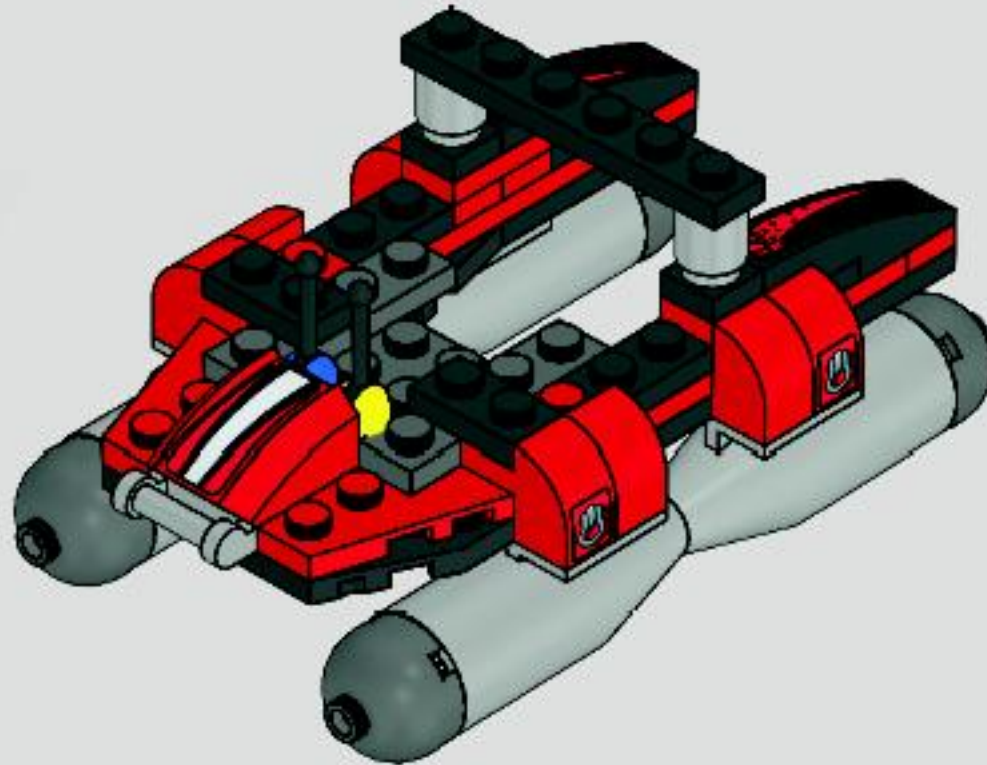



2x

14

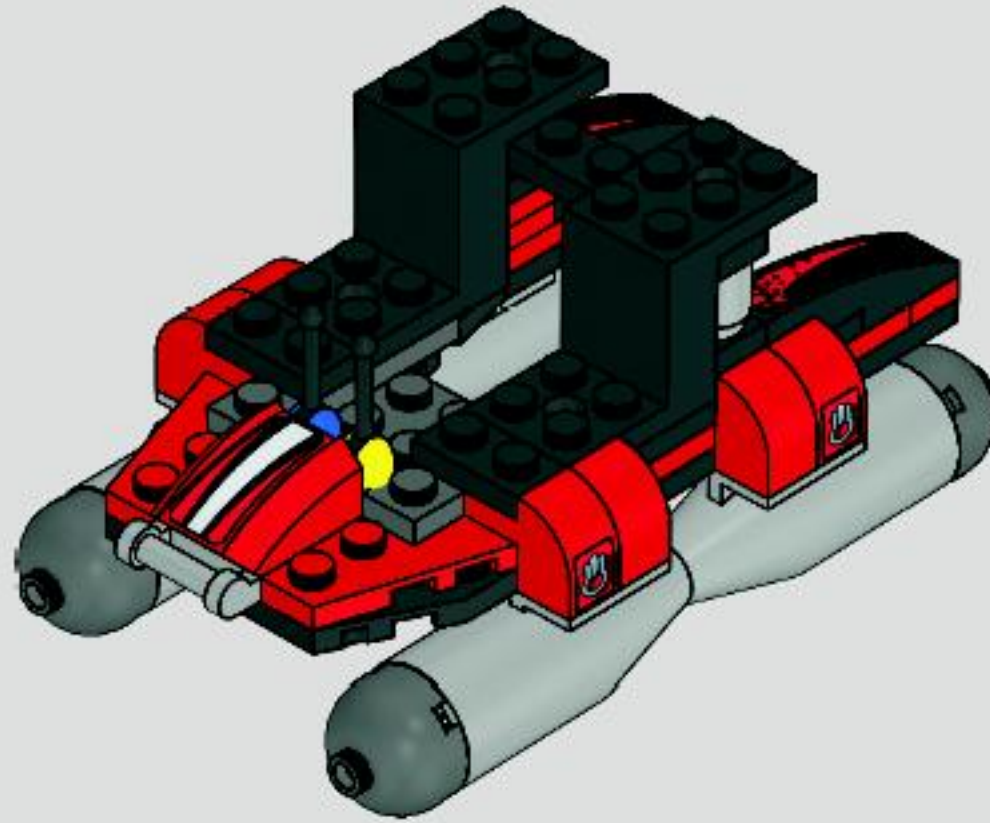



15

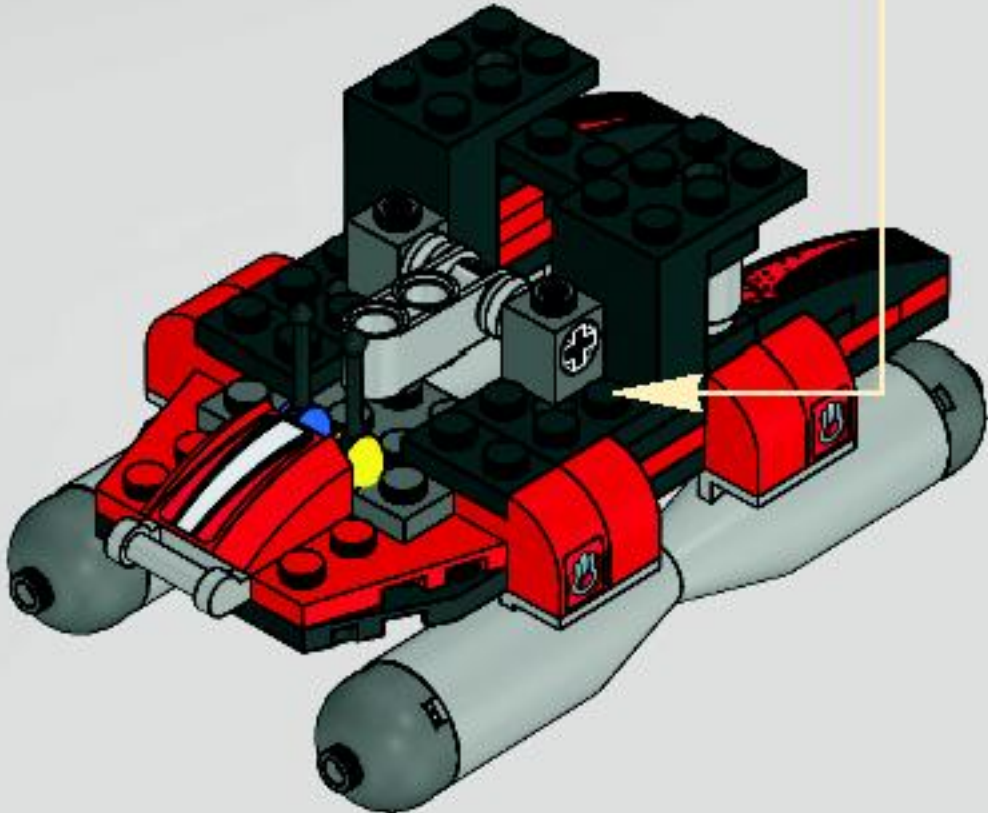
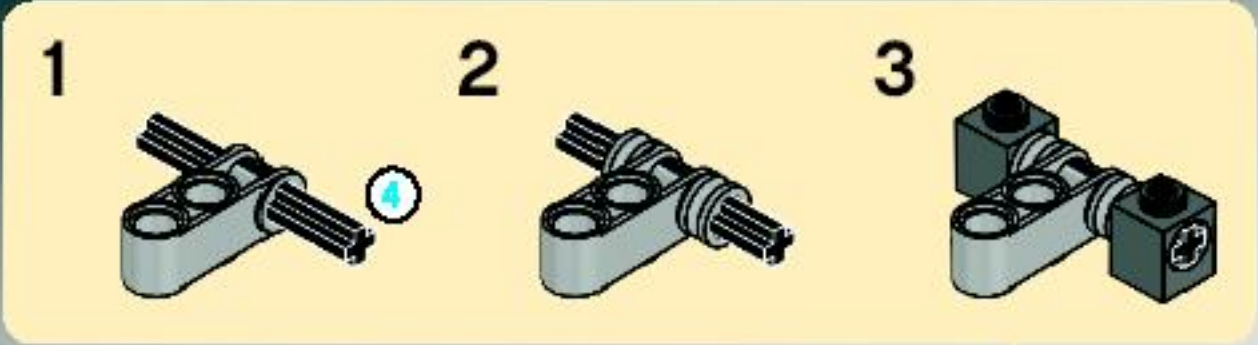



16

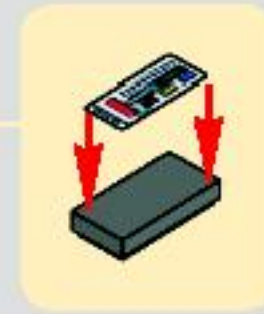
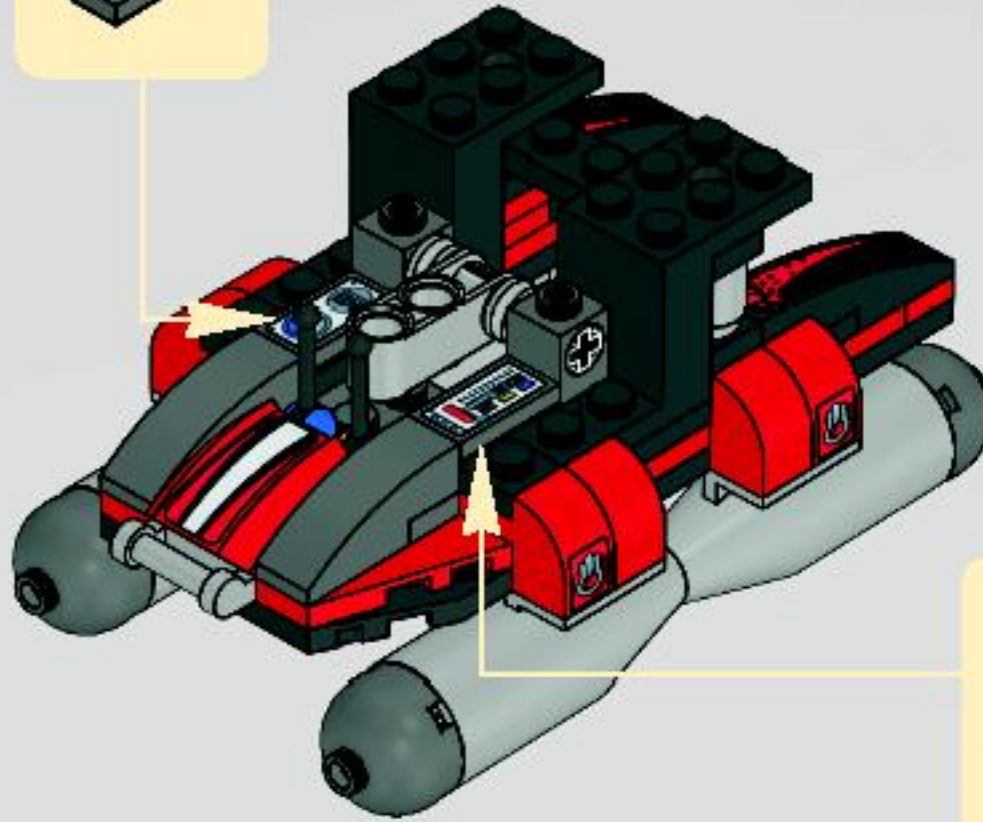
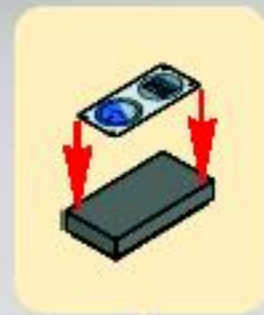

17

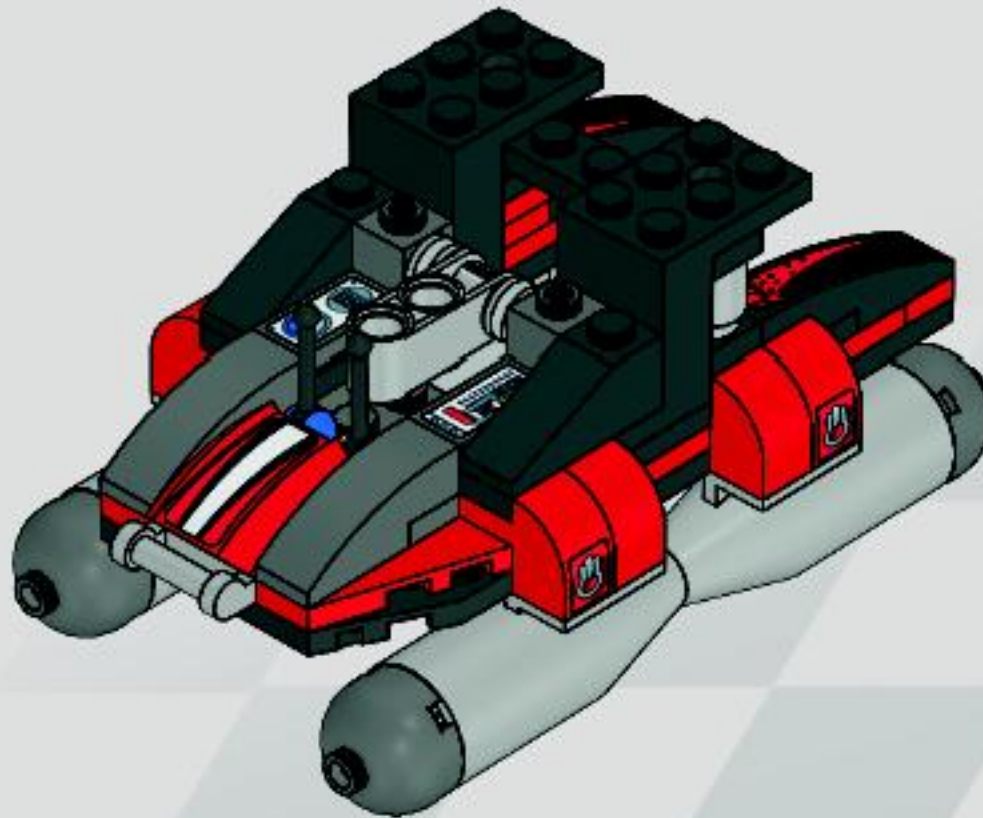



2x



2x



2x



2x

18

1

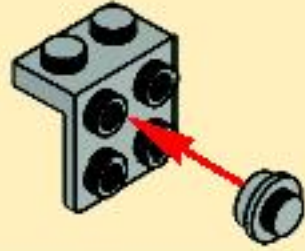

2

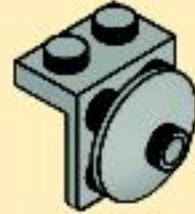

2x

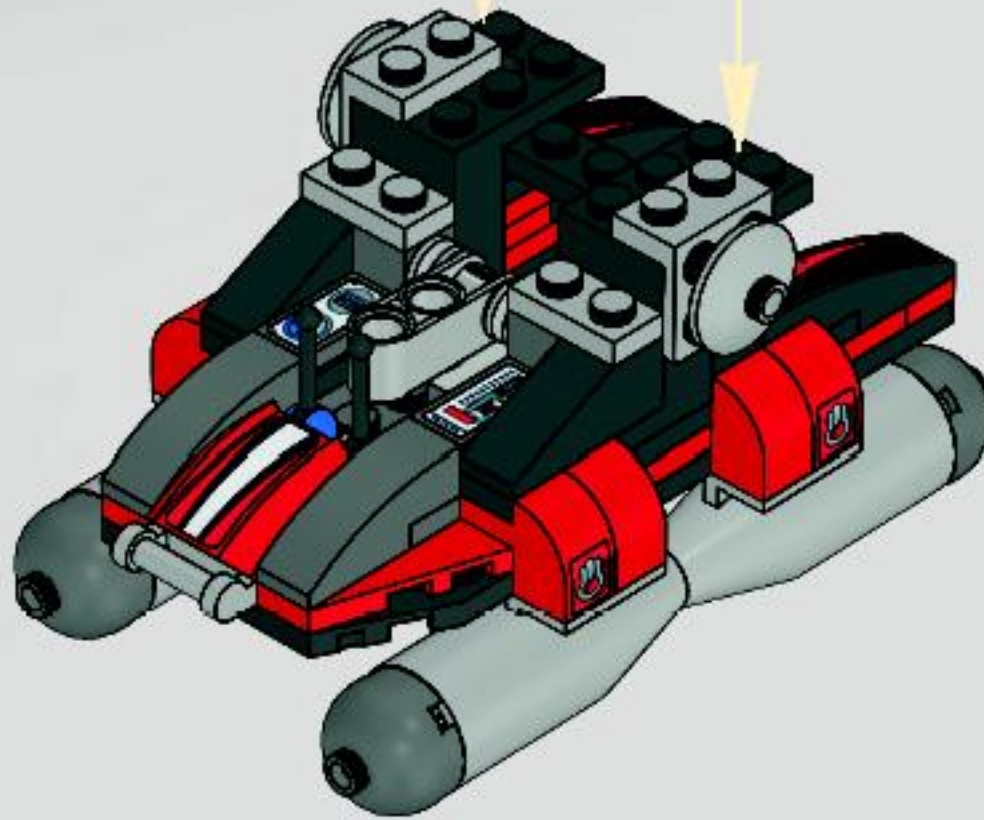



2x



4x



2x

19

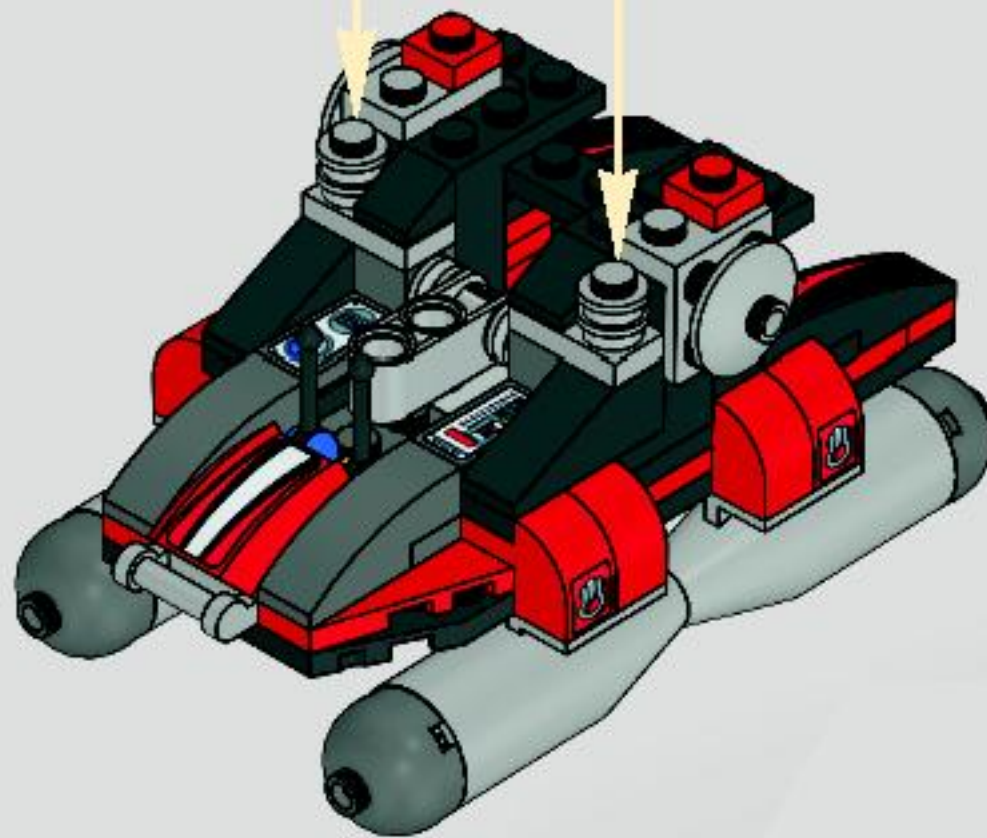
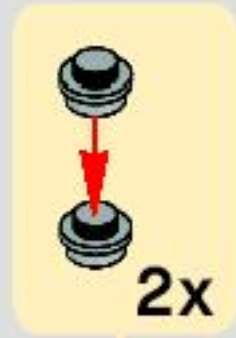



1x

20

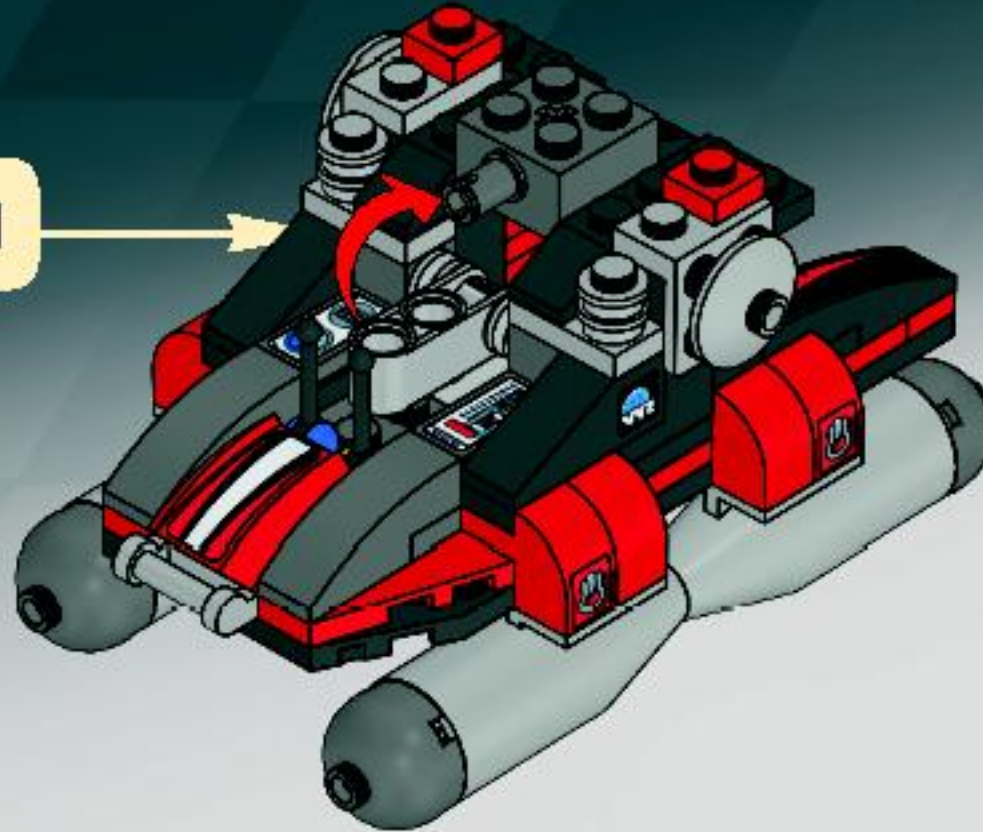

2x



1x



1x



2x



1x

21

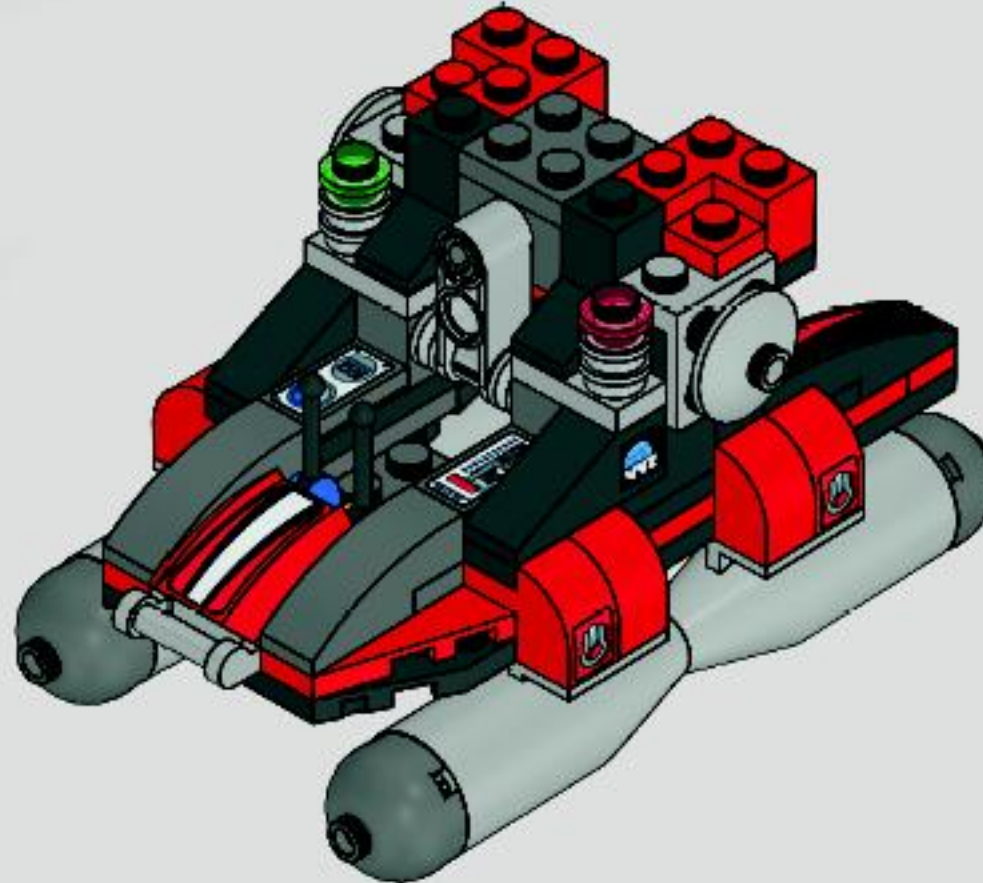



2x

22

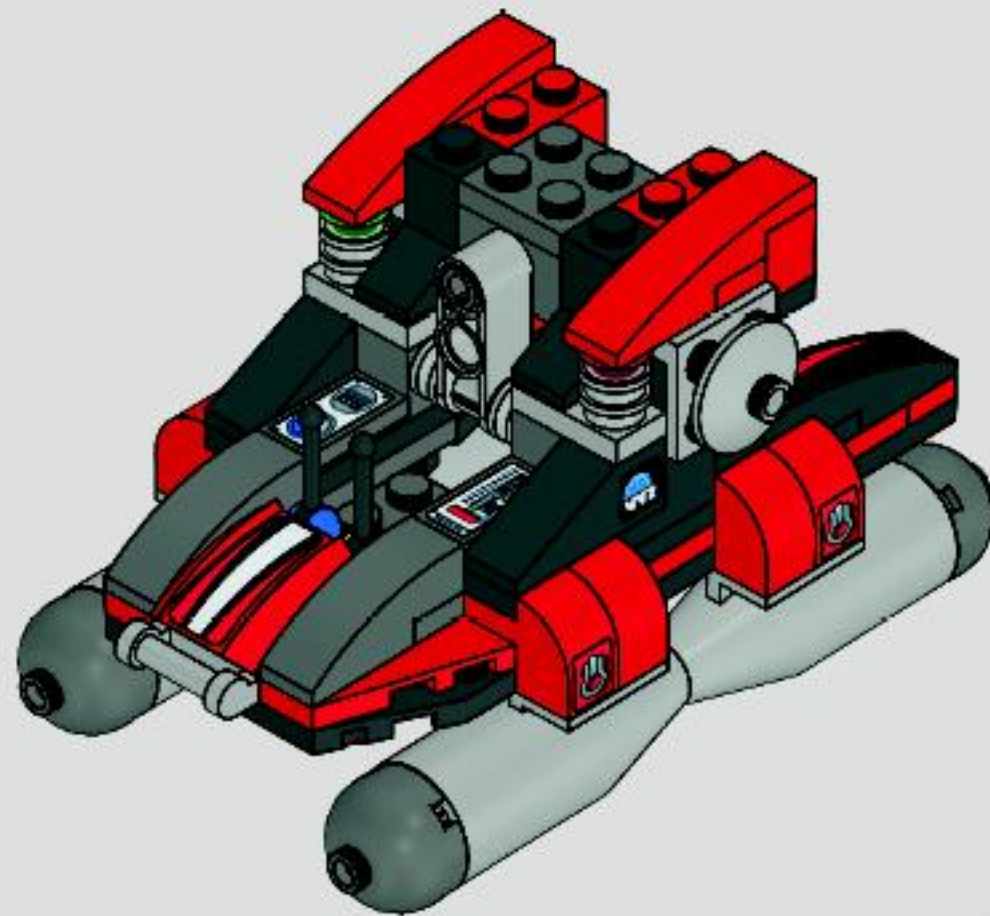



1 1:1

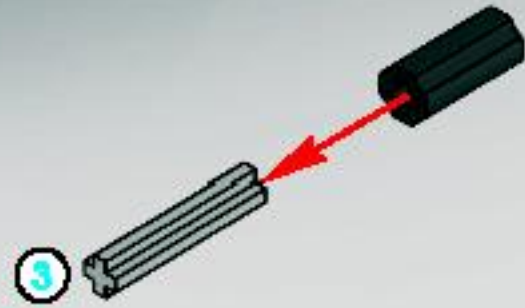

2

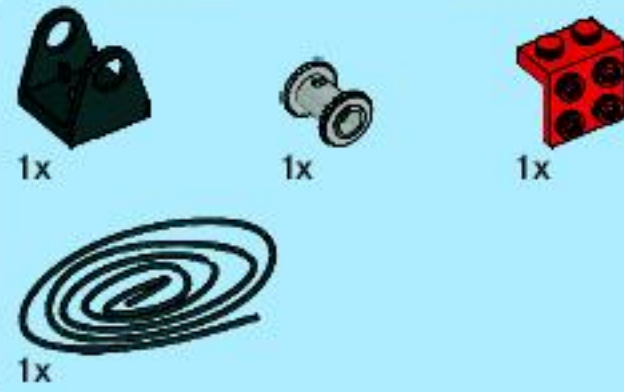

3

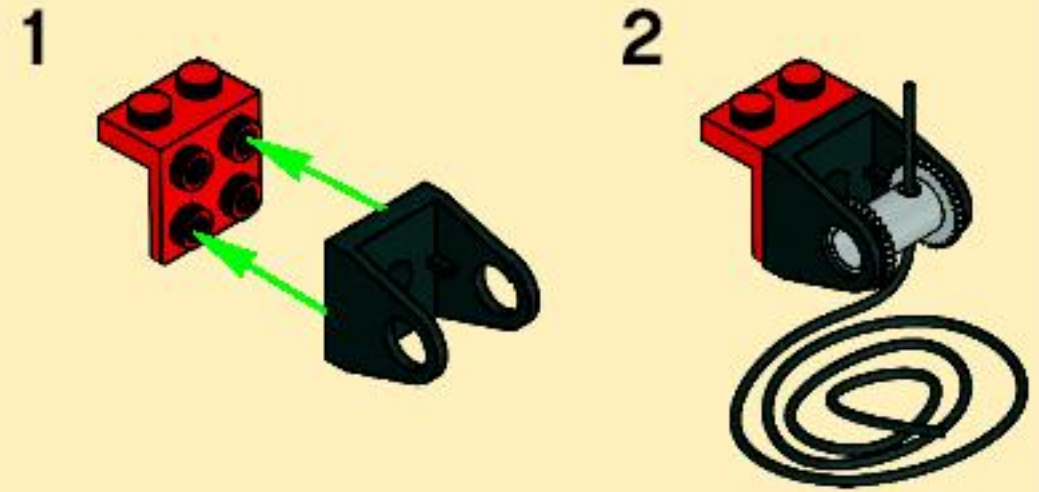



1x

4



23

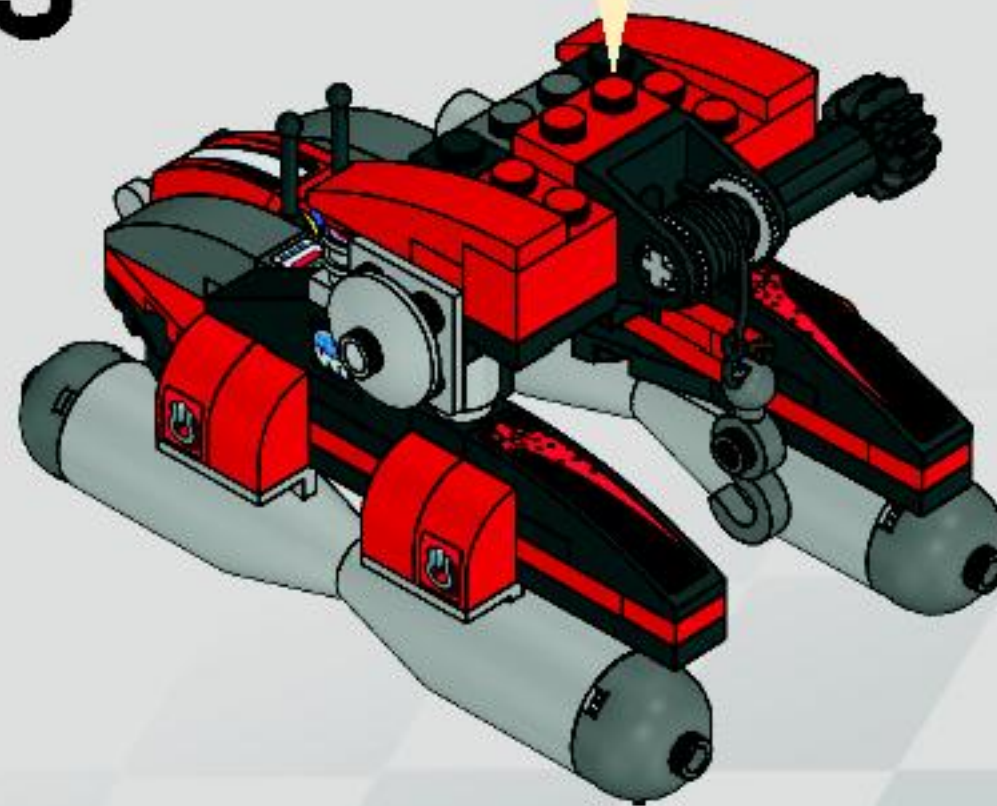



2x



1x

24

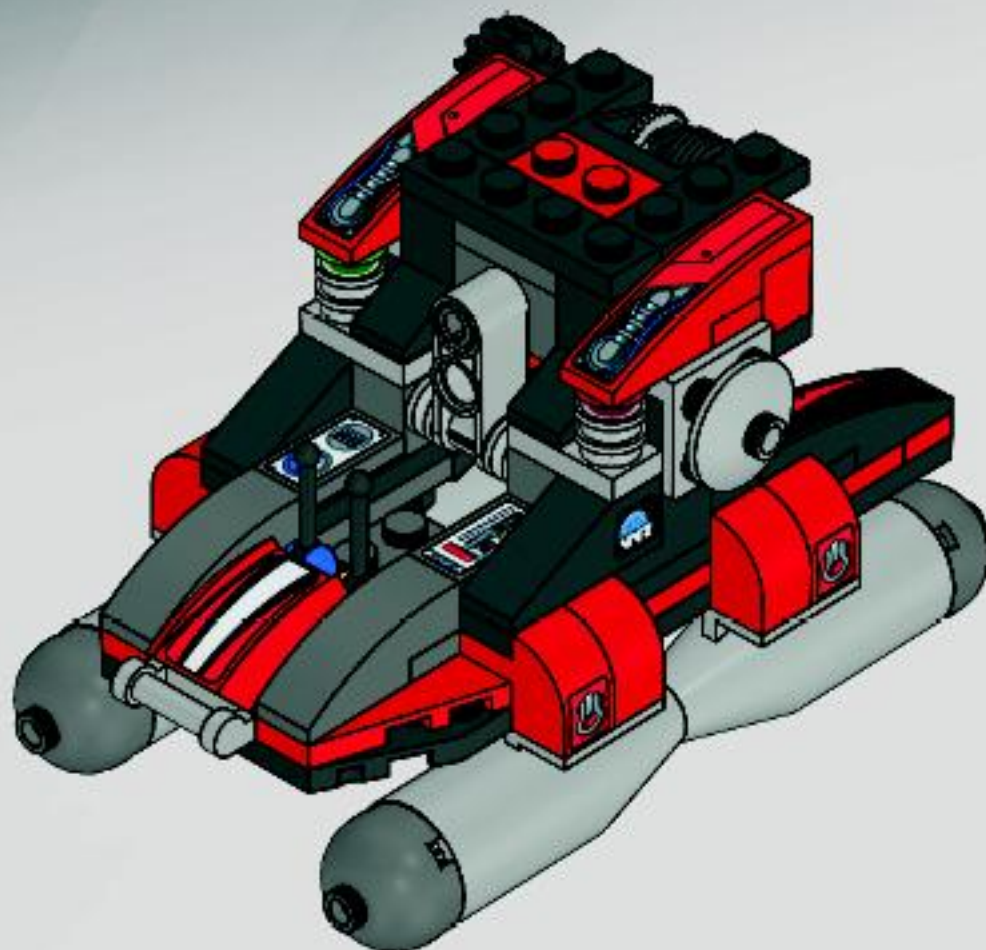



1x



2x



1x

25

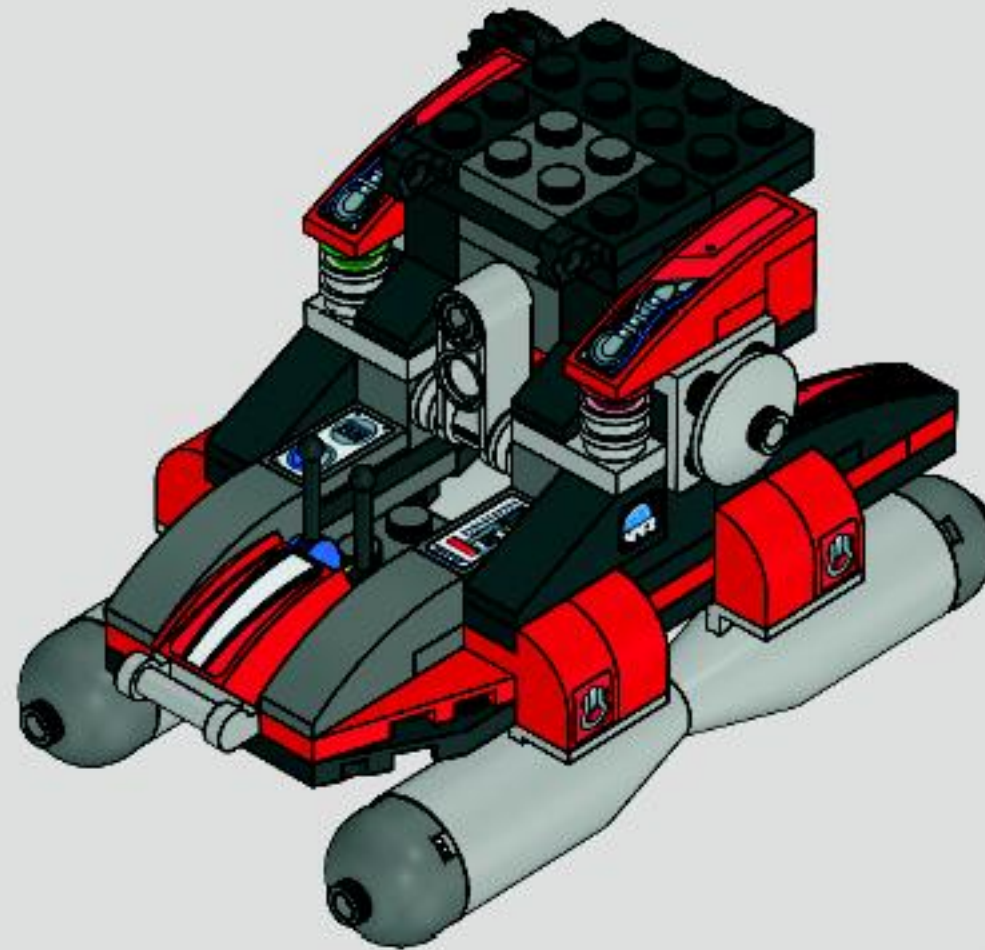

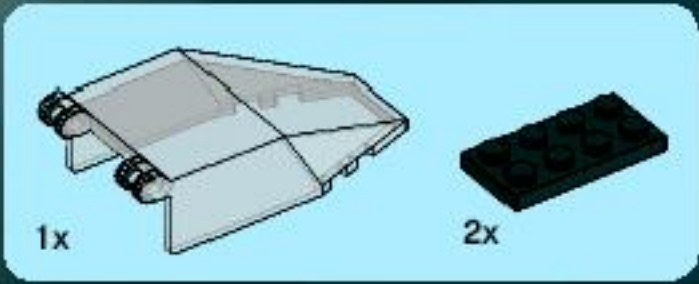

26

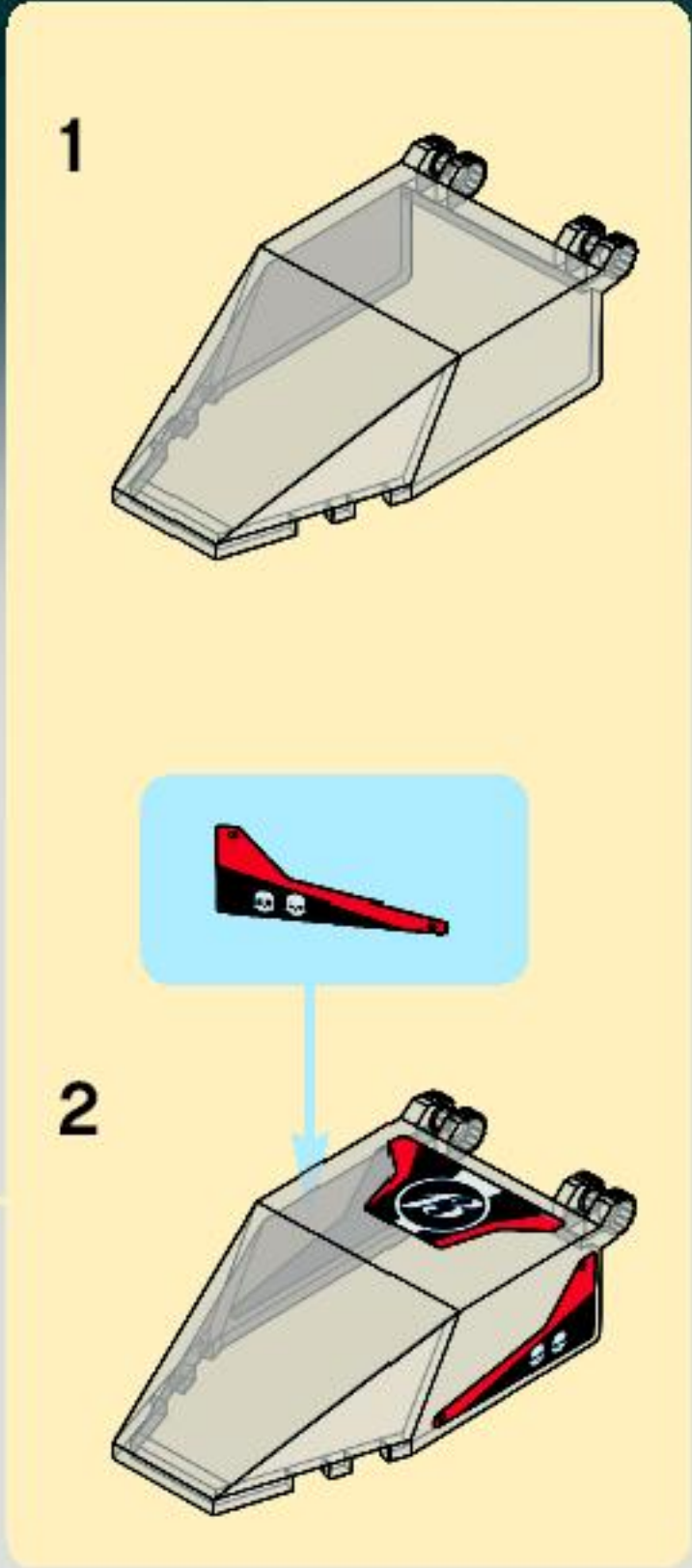
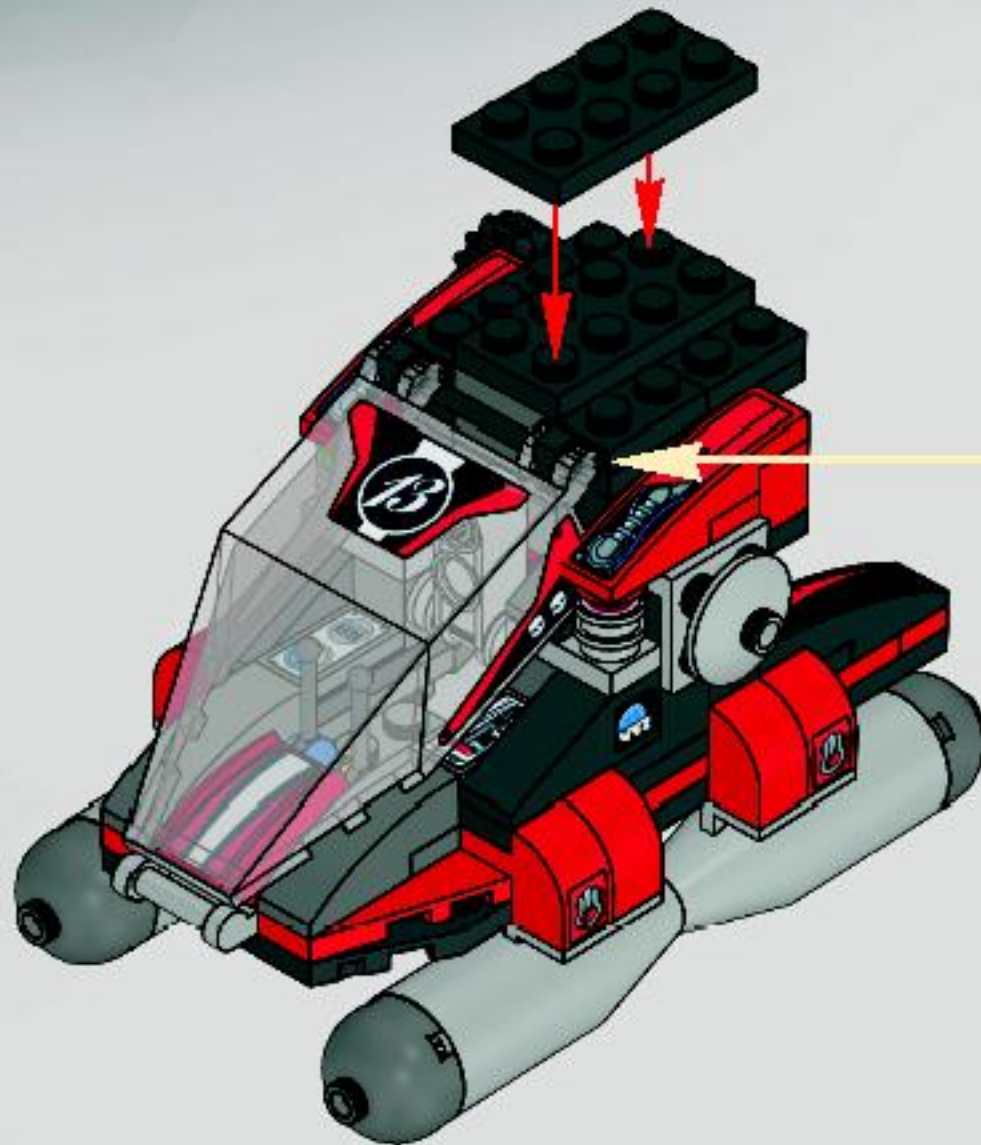

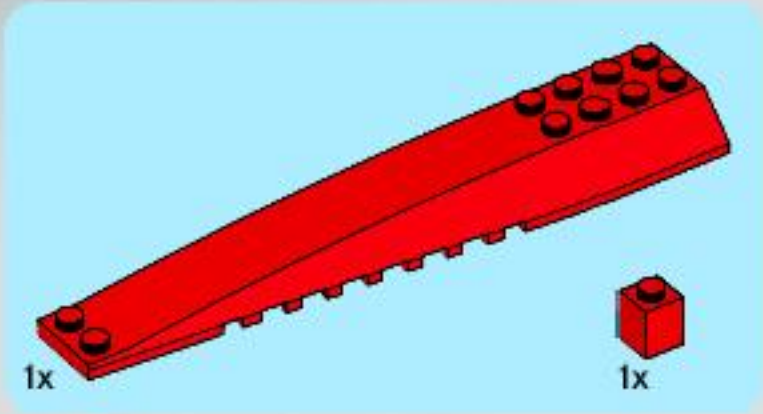

1

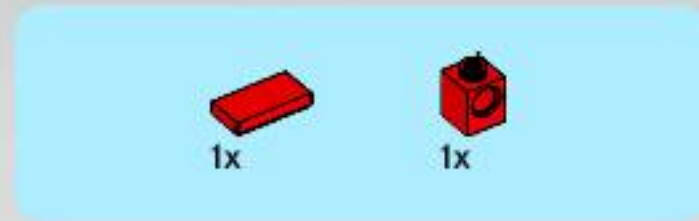
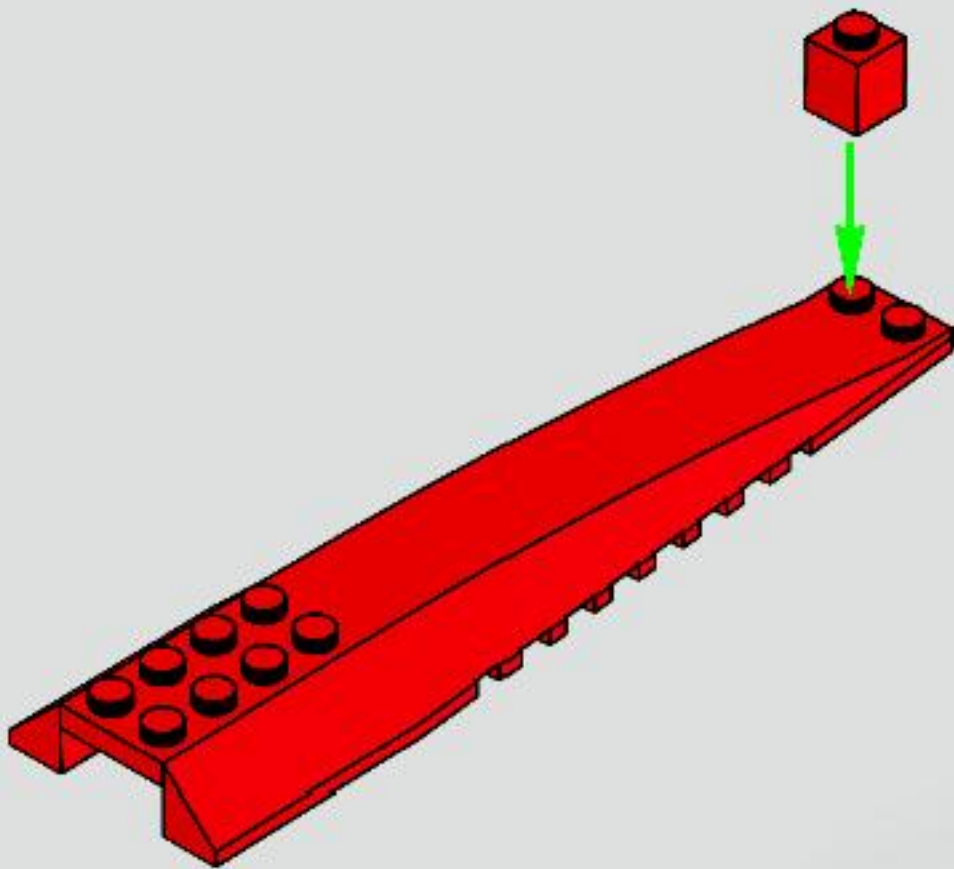

2

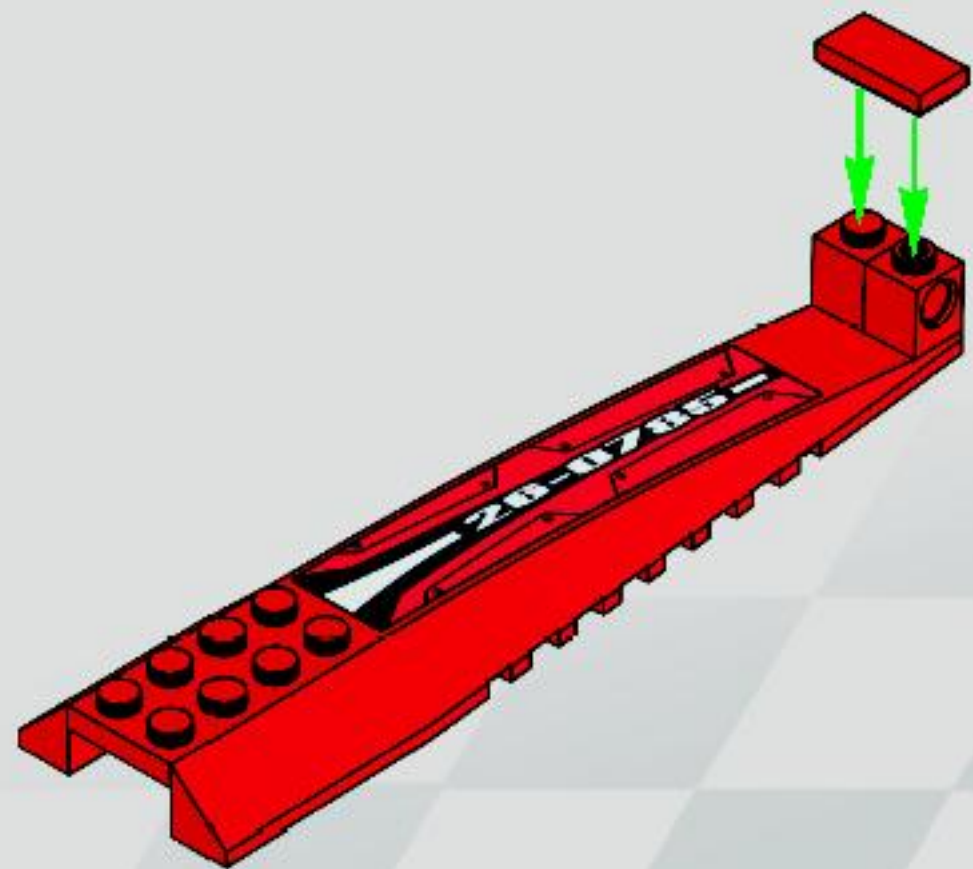



1x

3

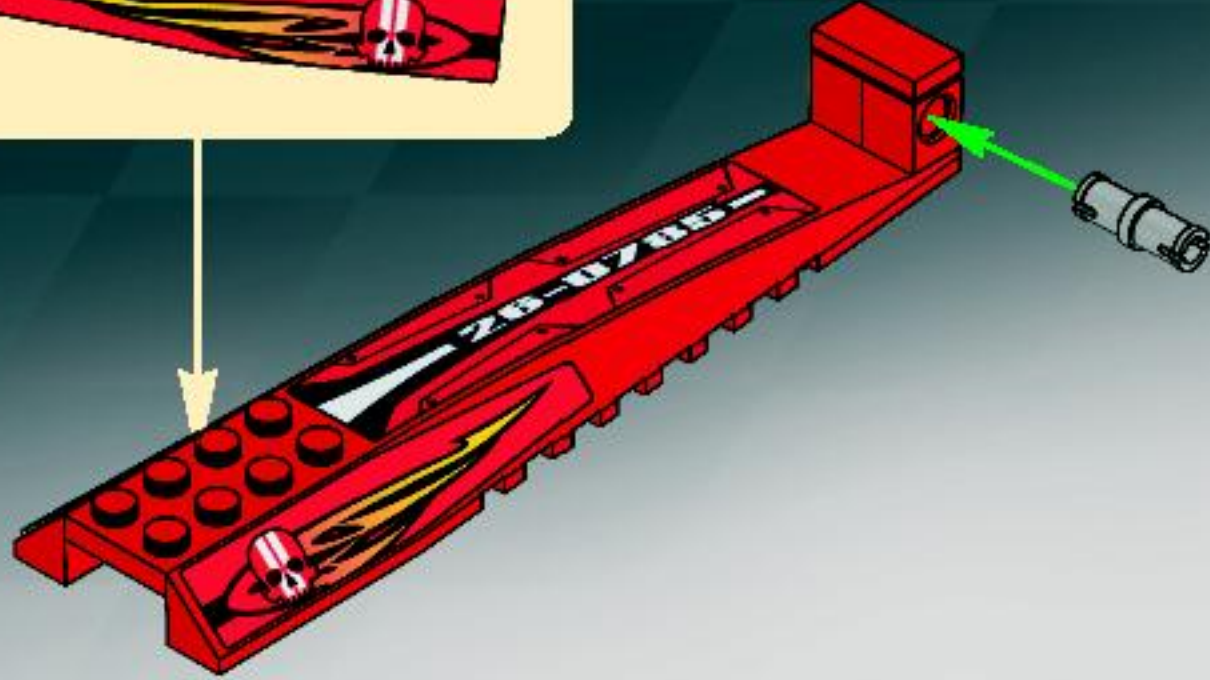

27

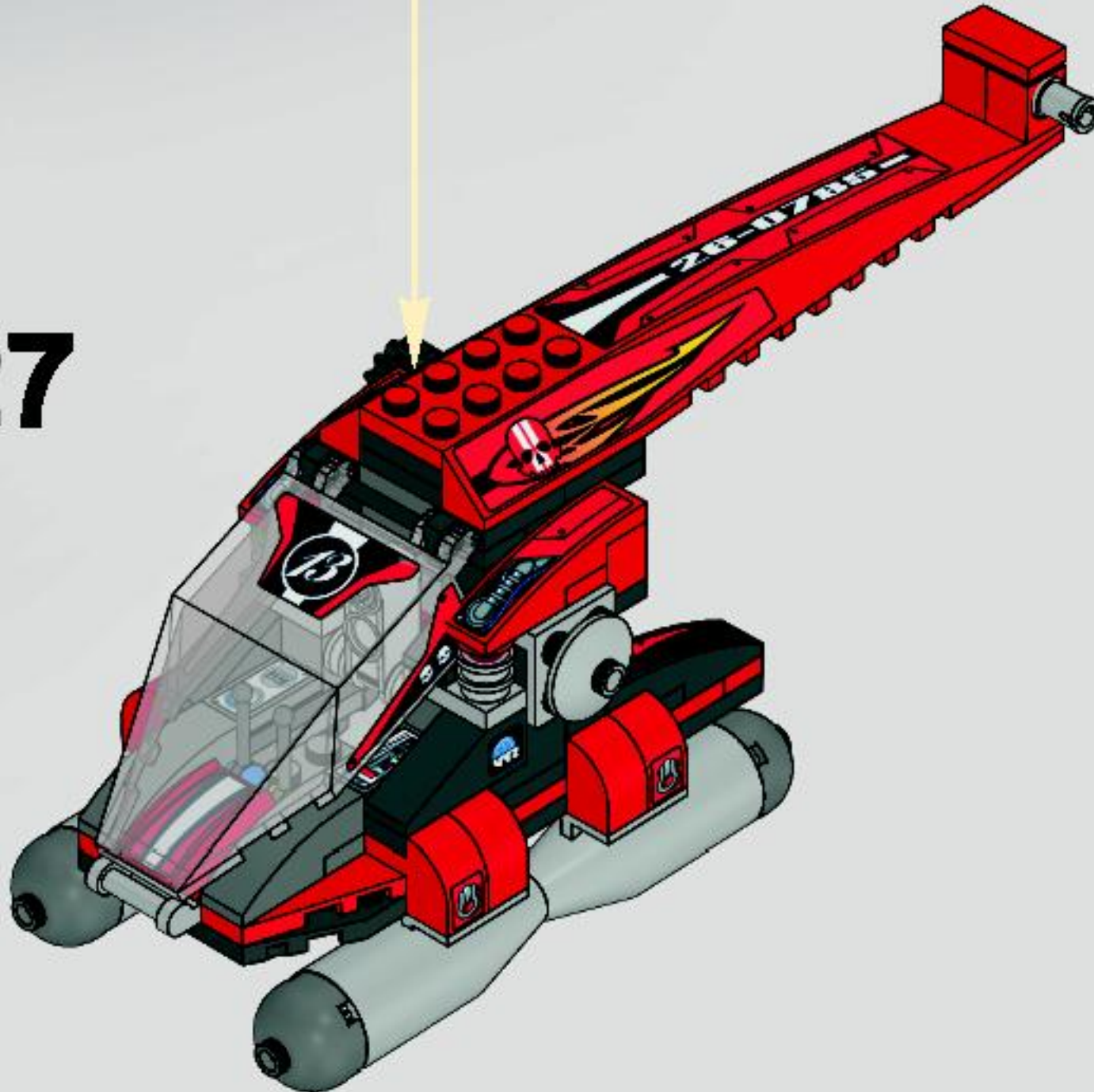



2x



1x



1x

28

1



2

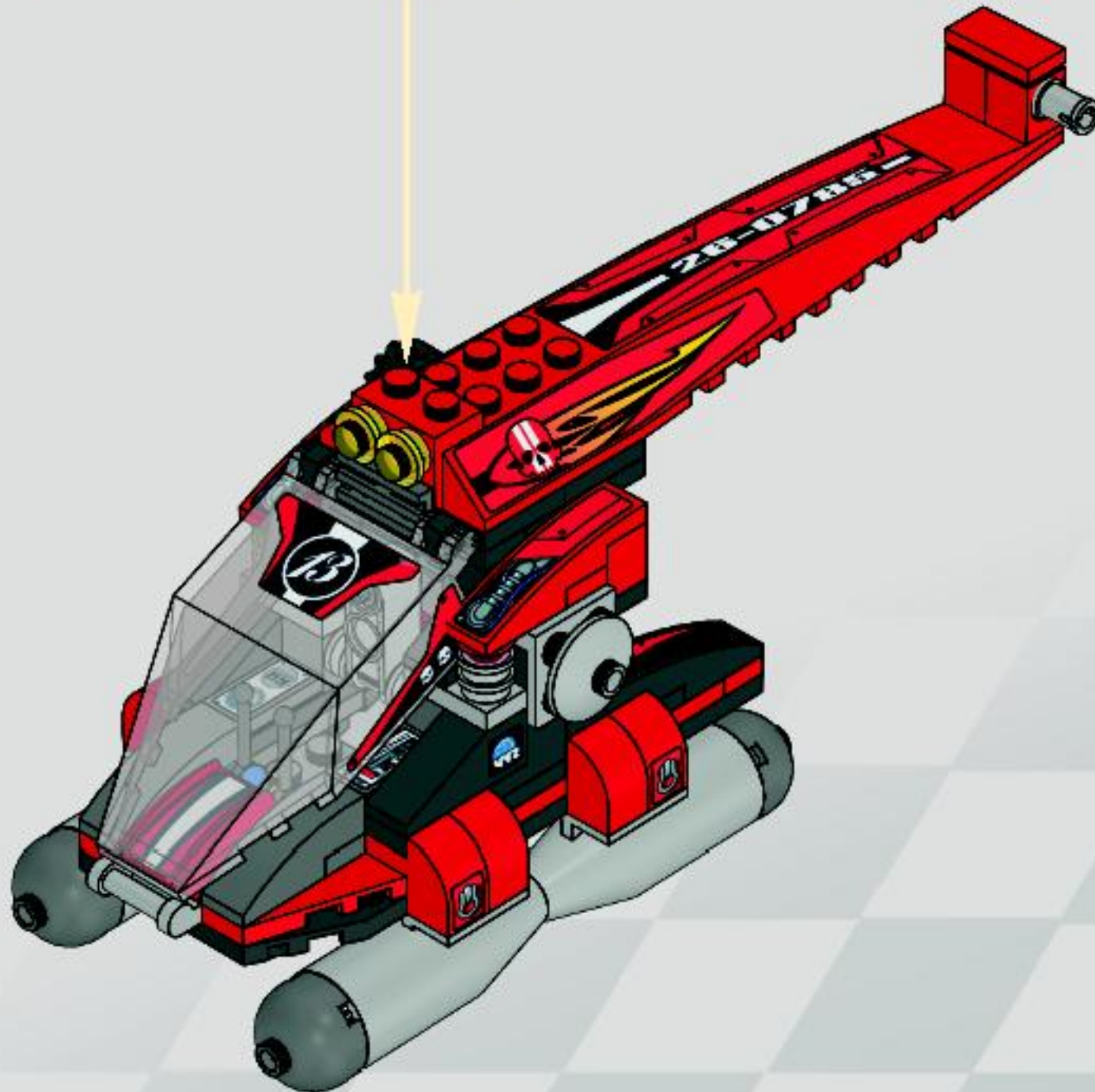



2x



1x



1x



1x

29

1

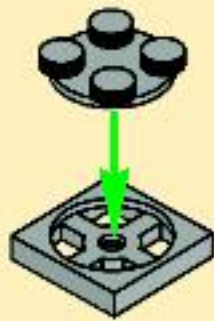

2

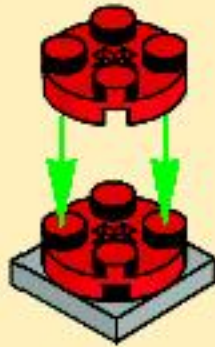

3

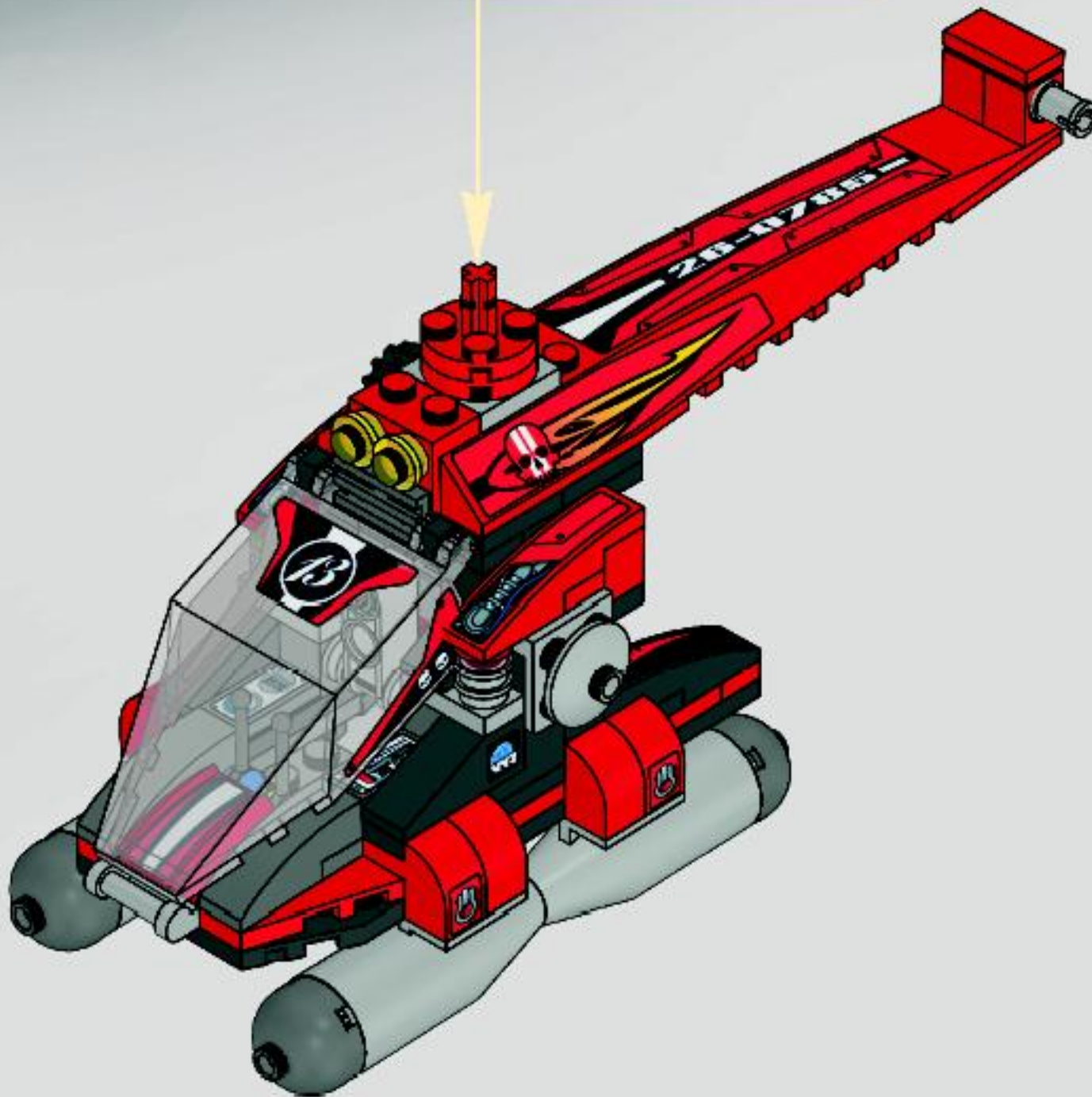
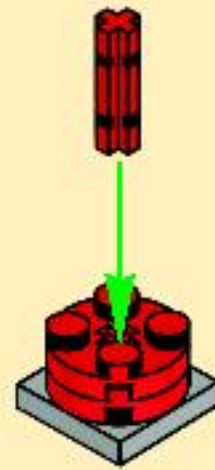



1

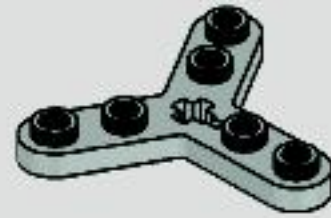

2





3

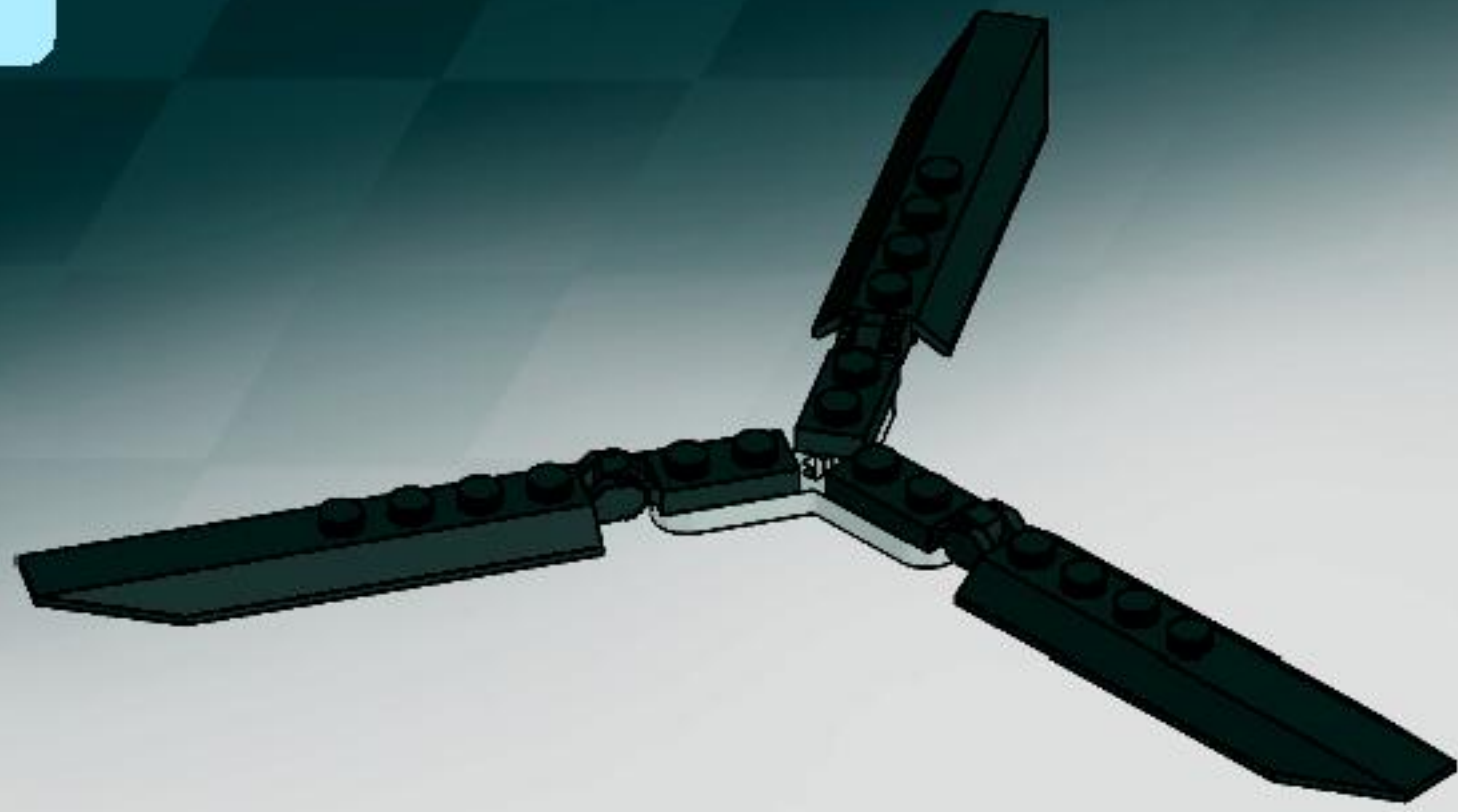

4

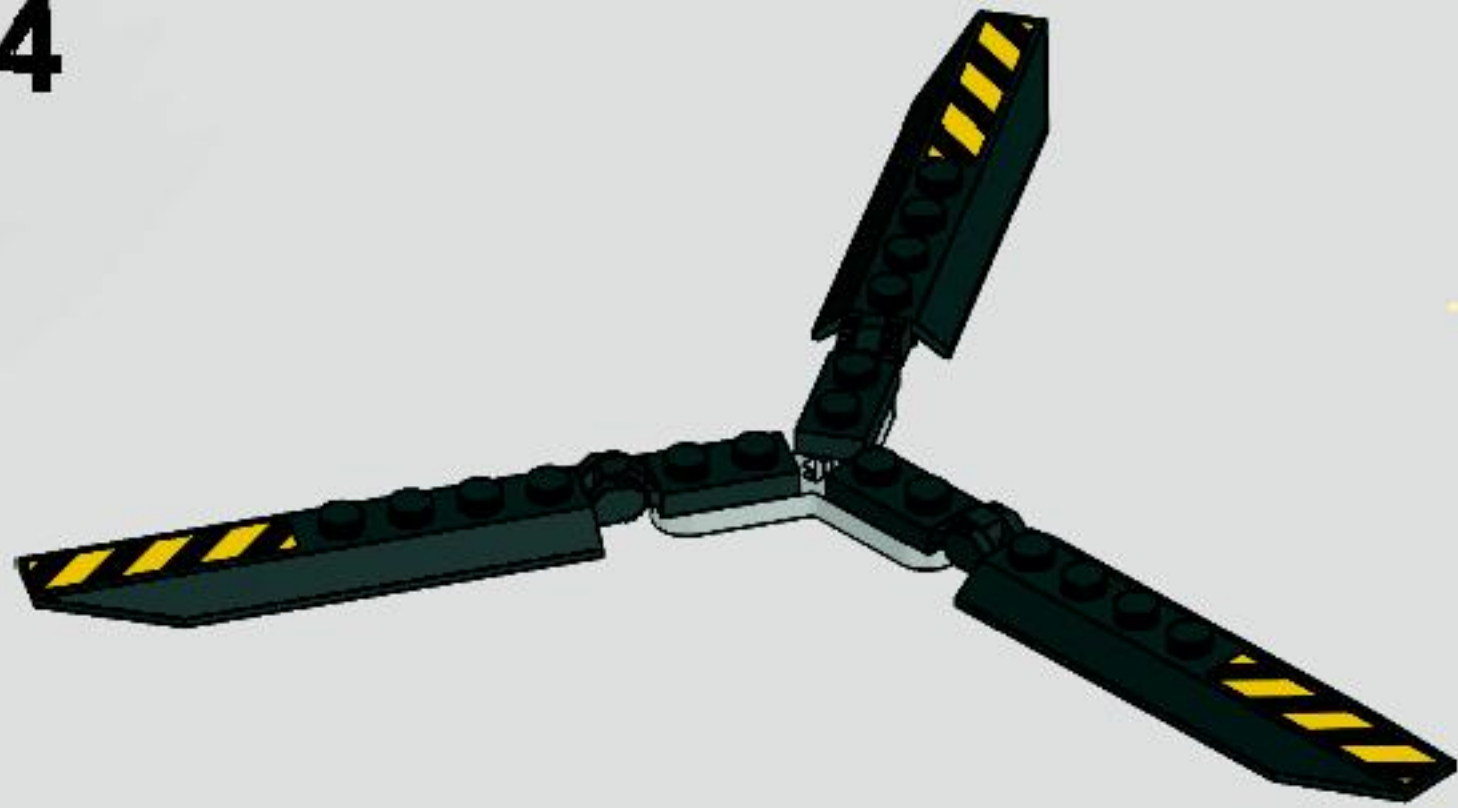

30

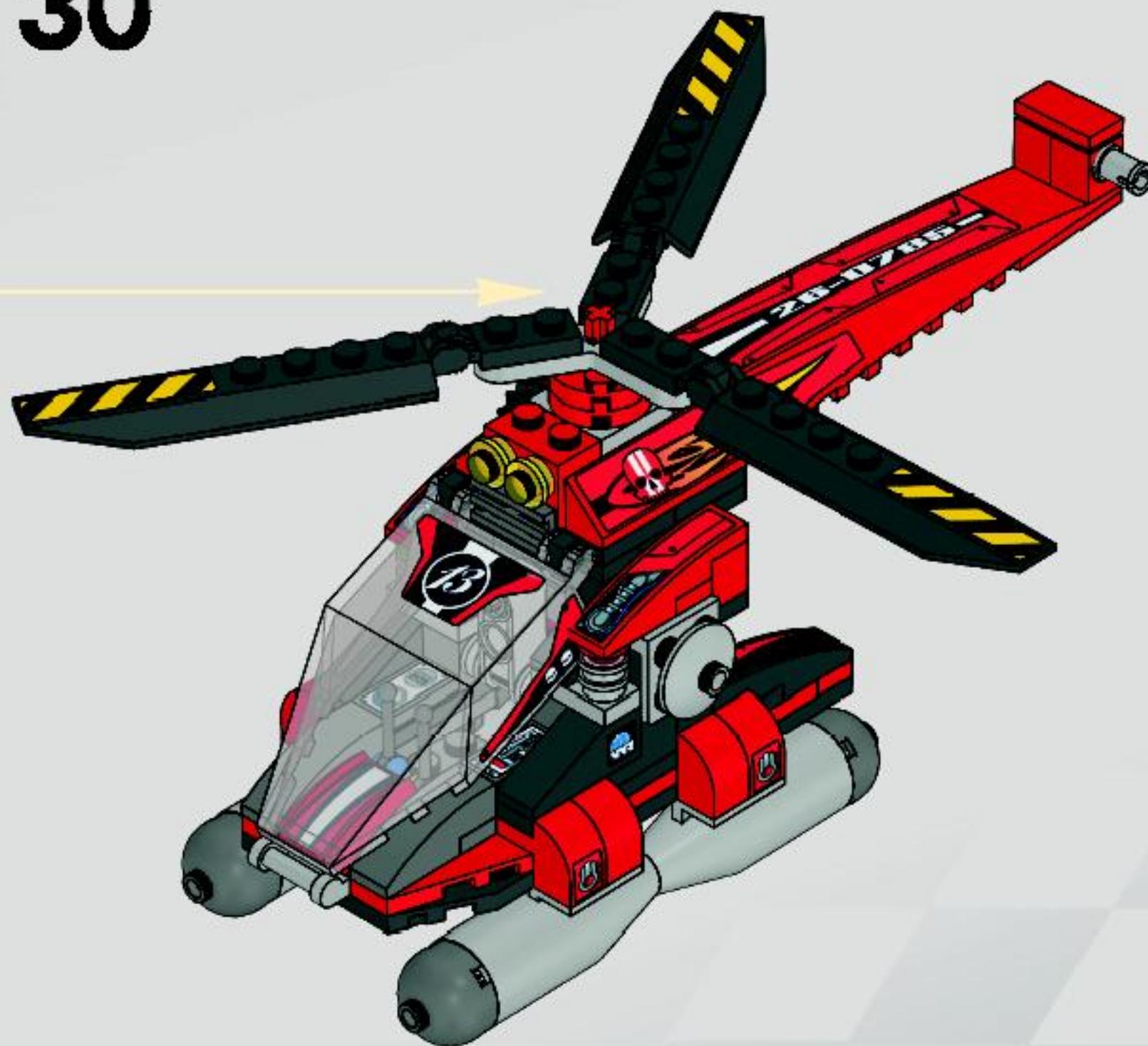



1x



1x

31



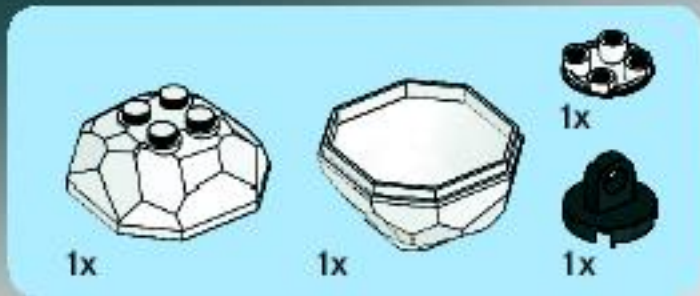

32

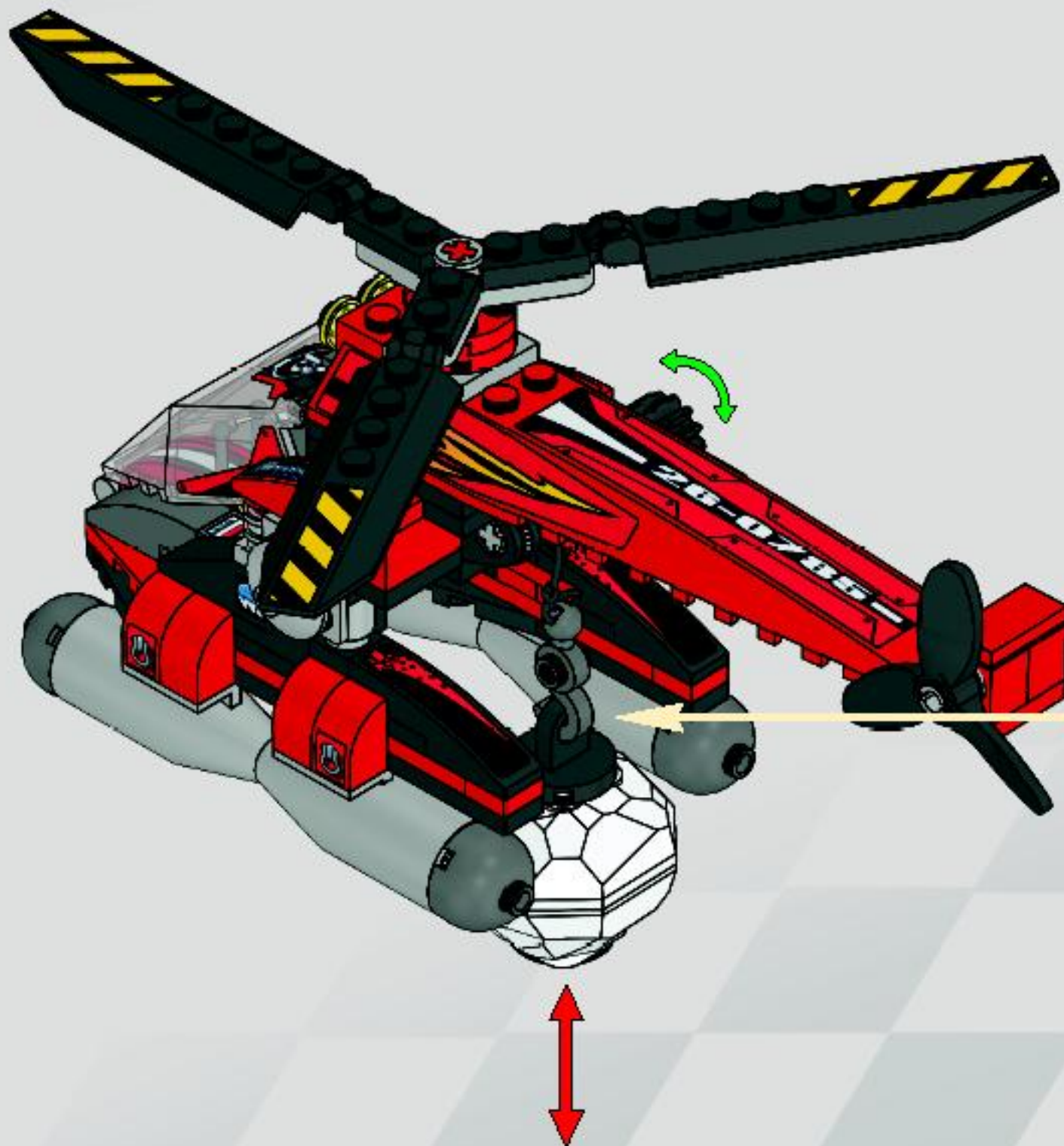
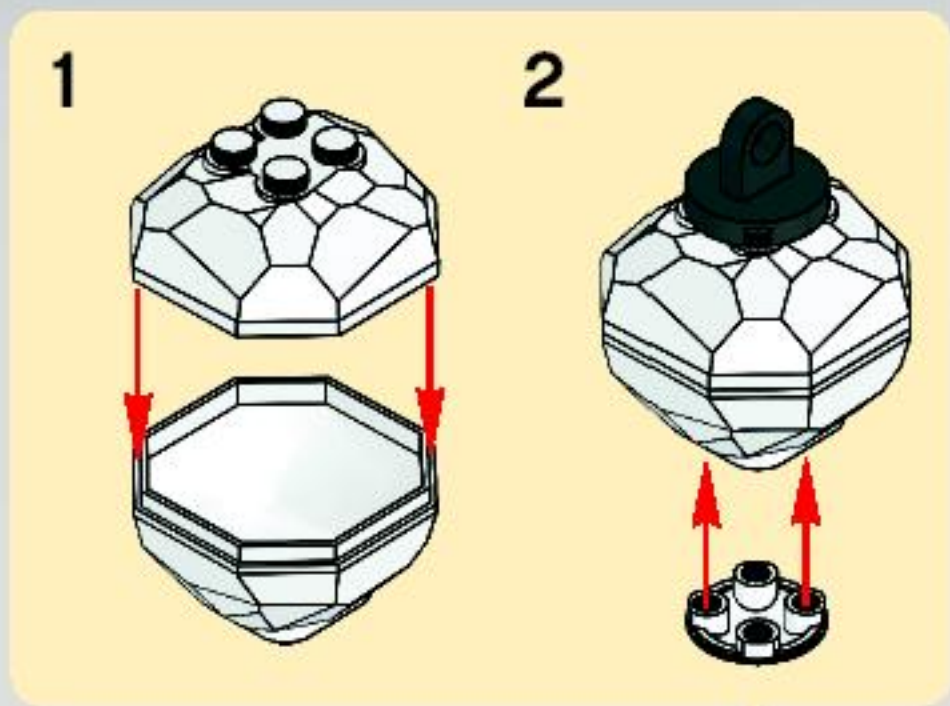

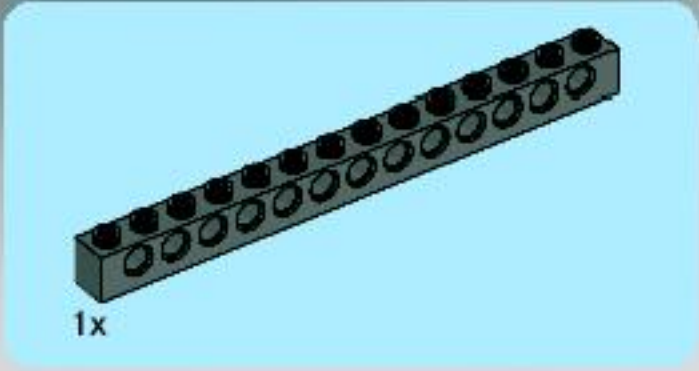
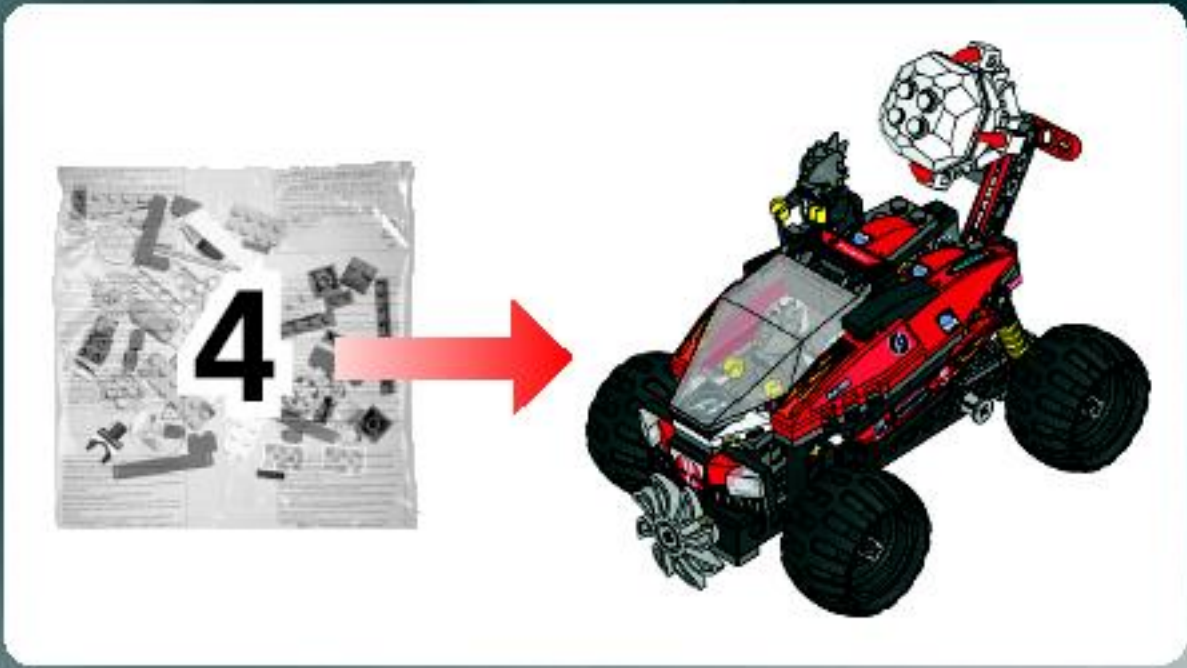

1

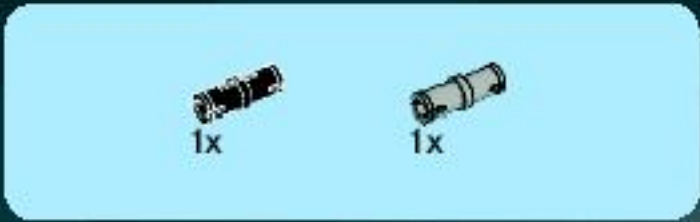
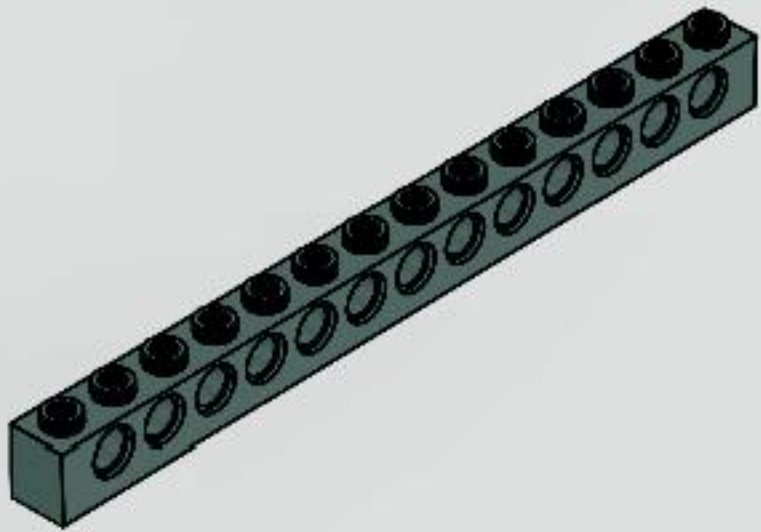

2

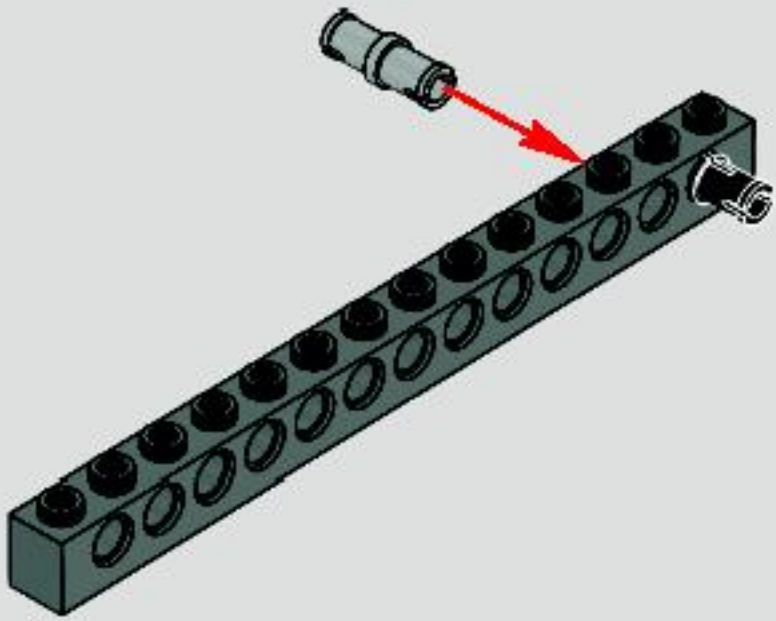

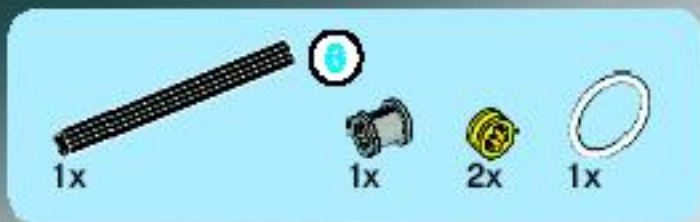

3

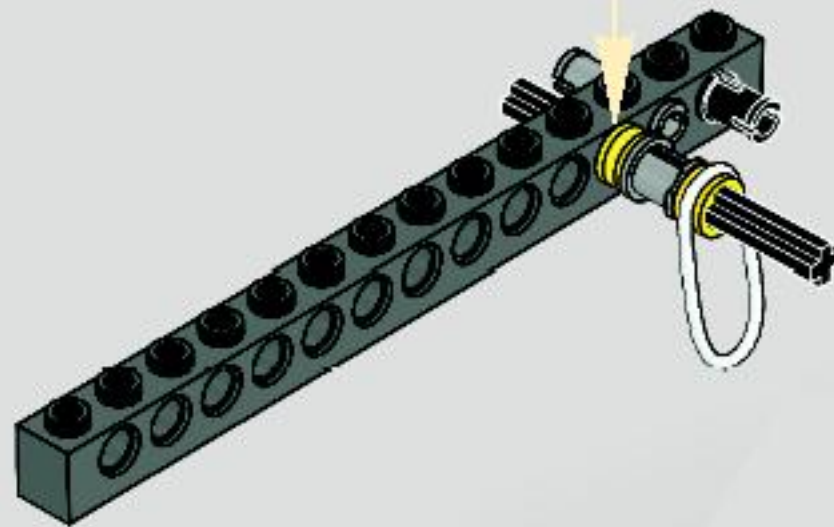
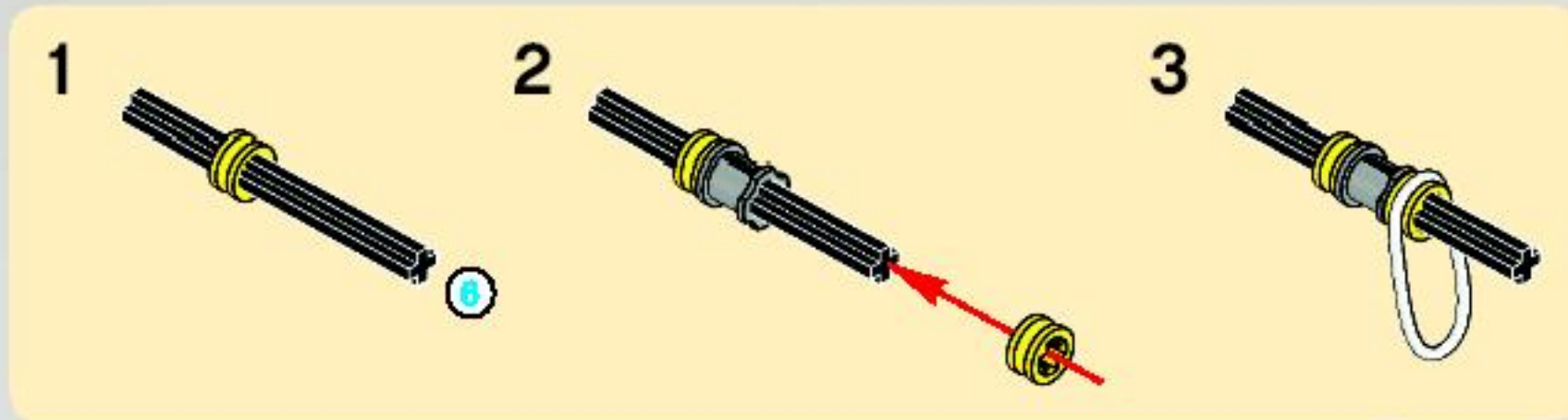

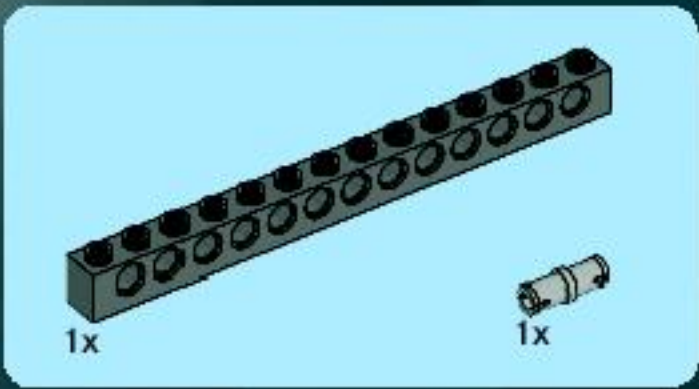

4

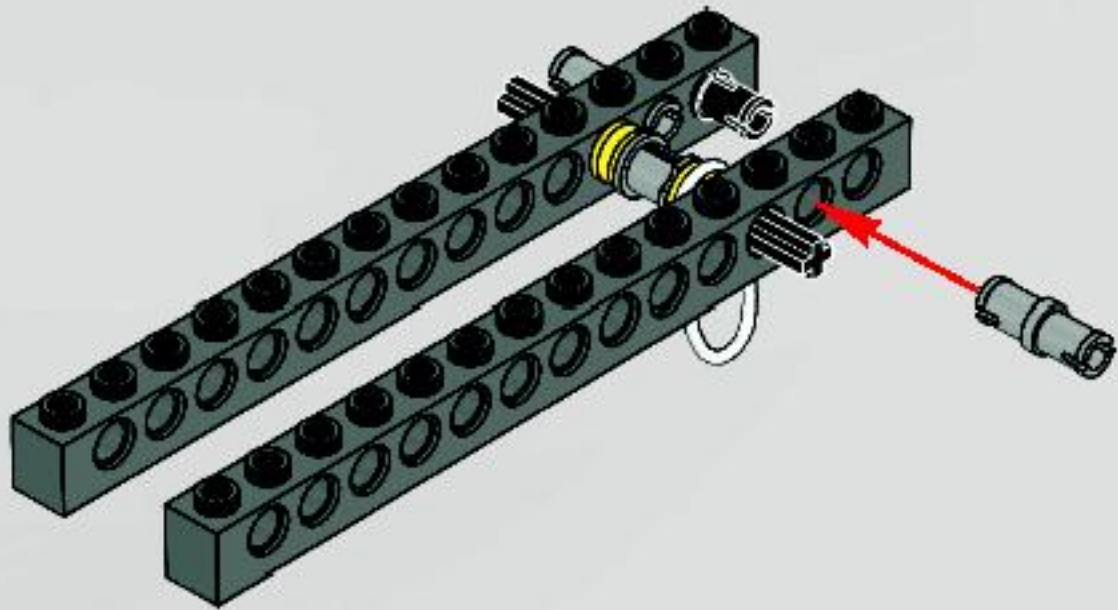

5

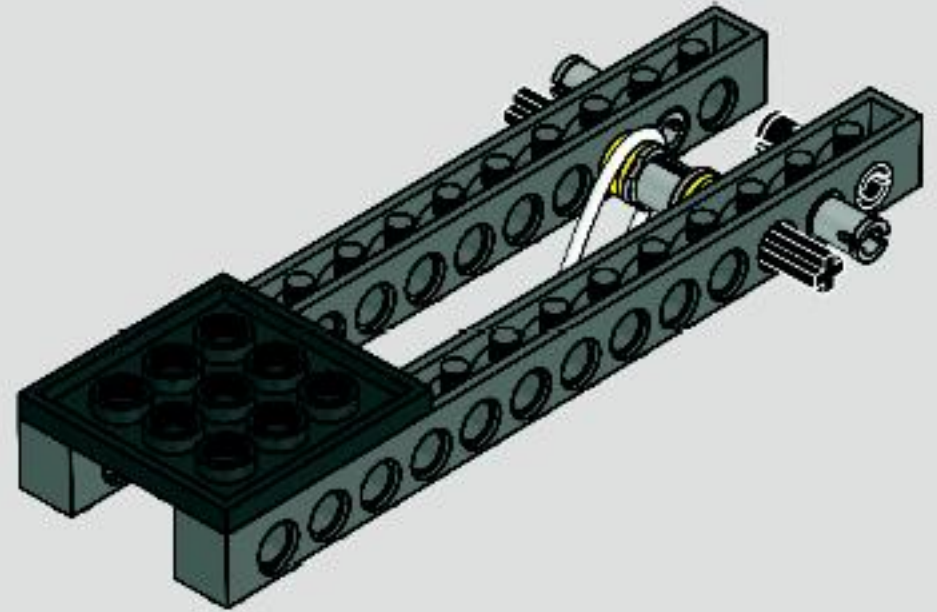



6

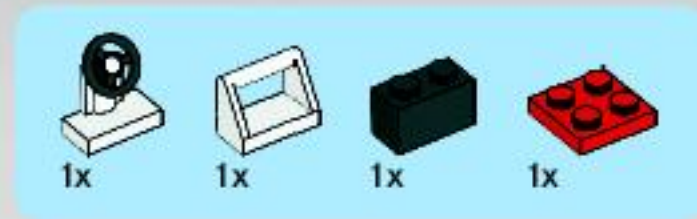
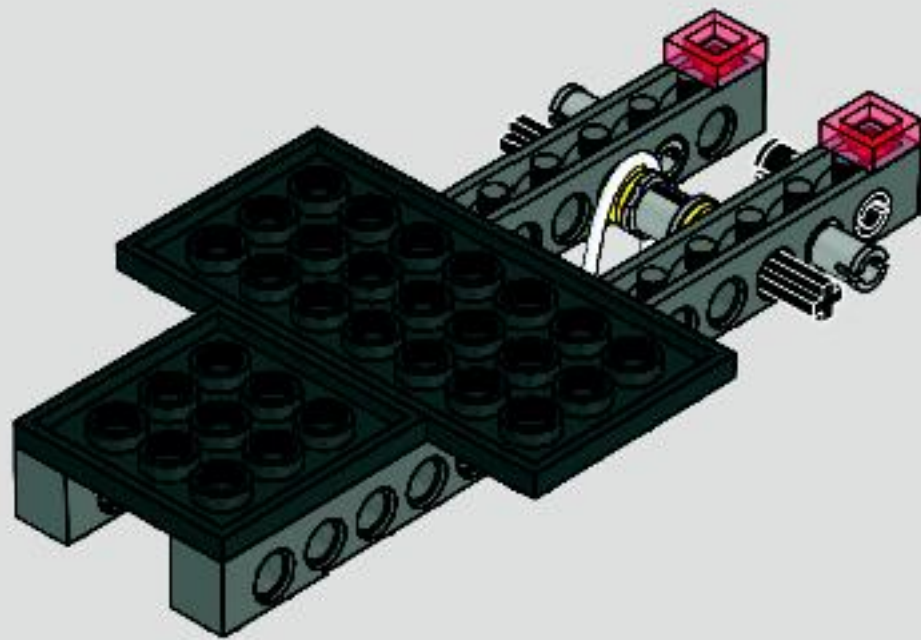

7

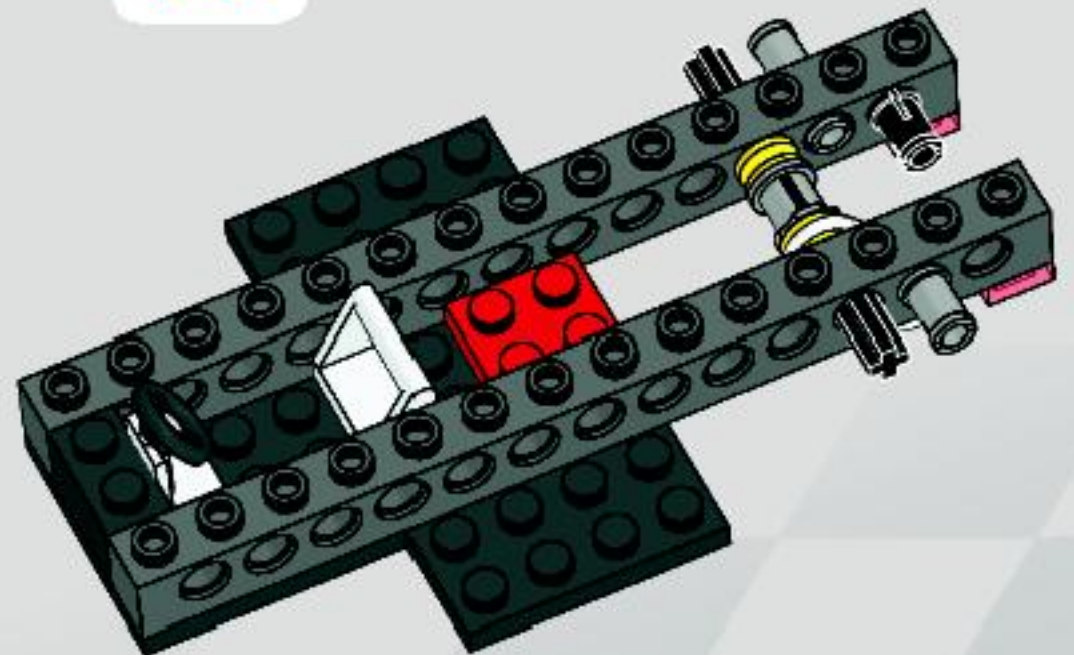

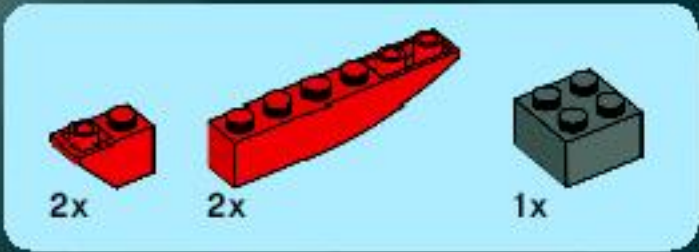

8

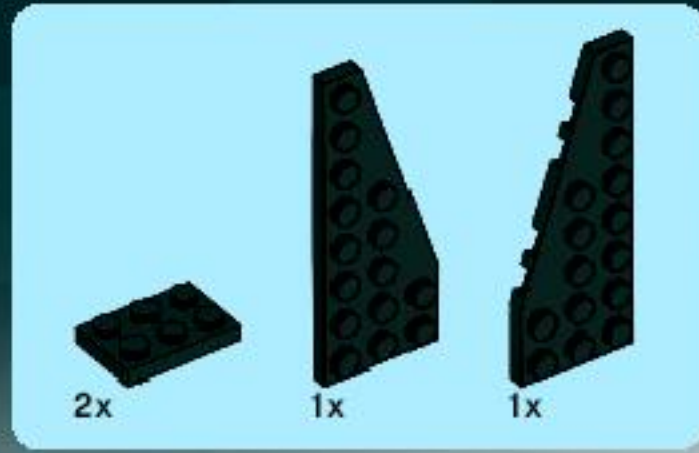
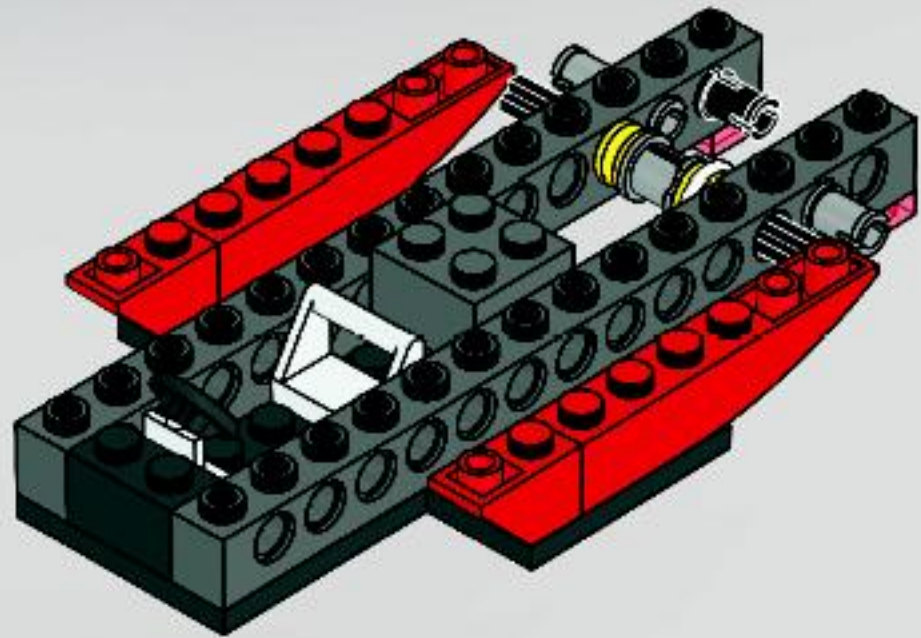

9

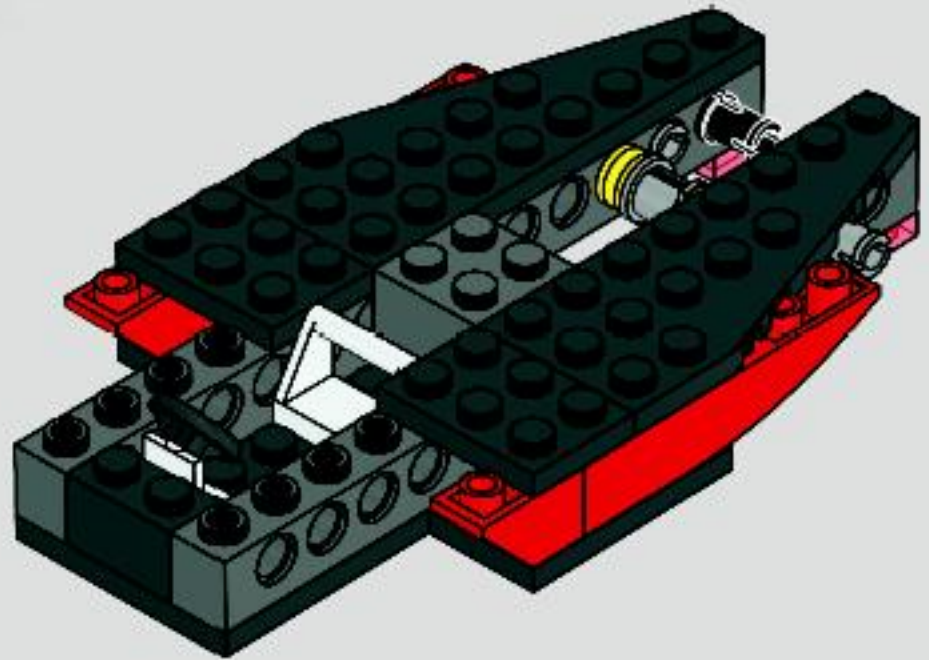



10

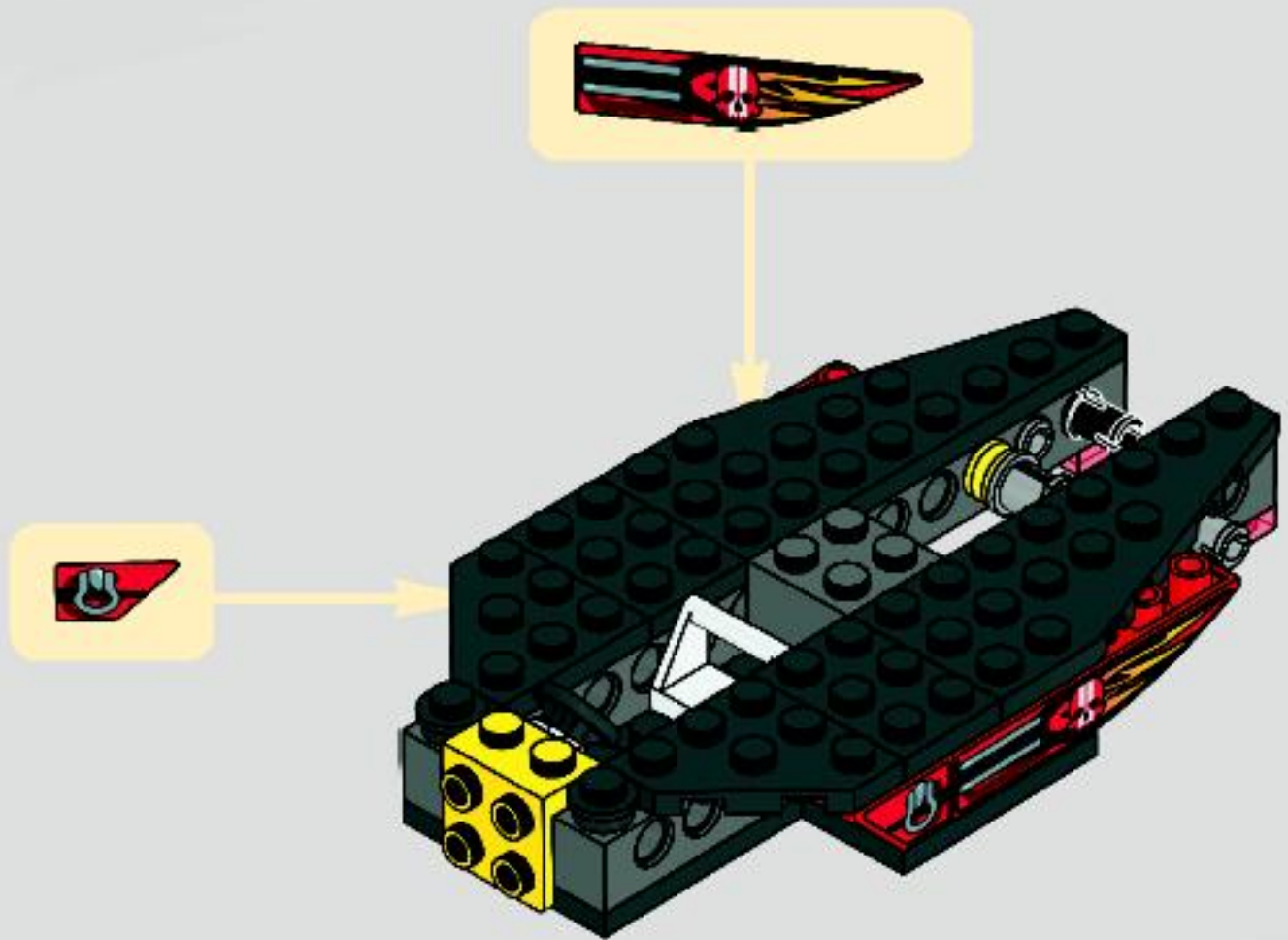

11

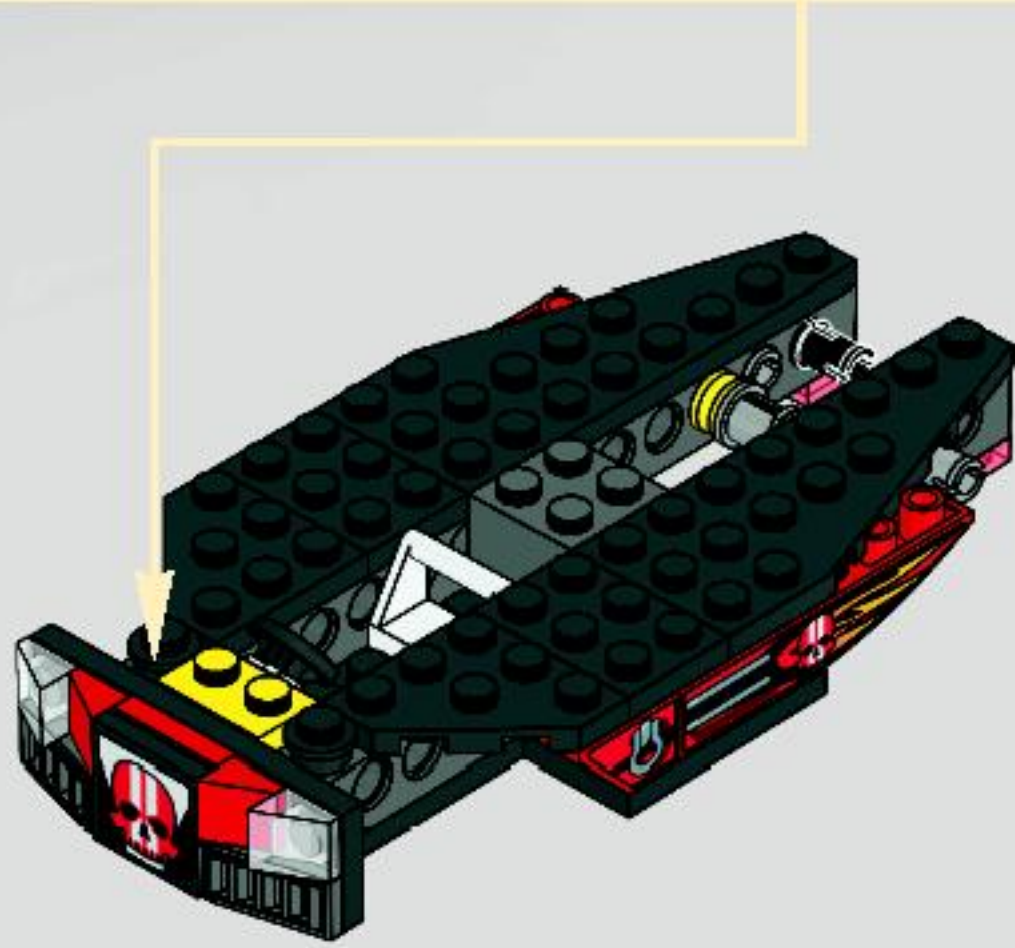
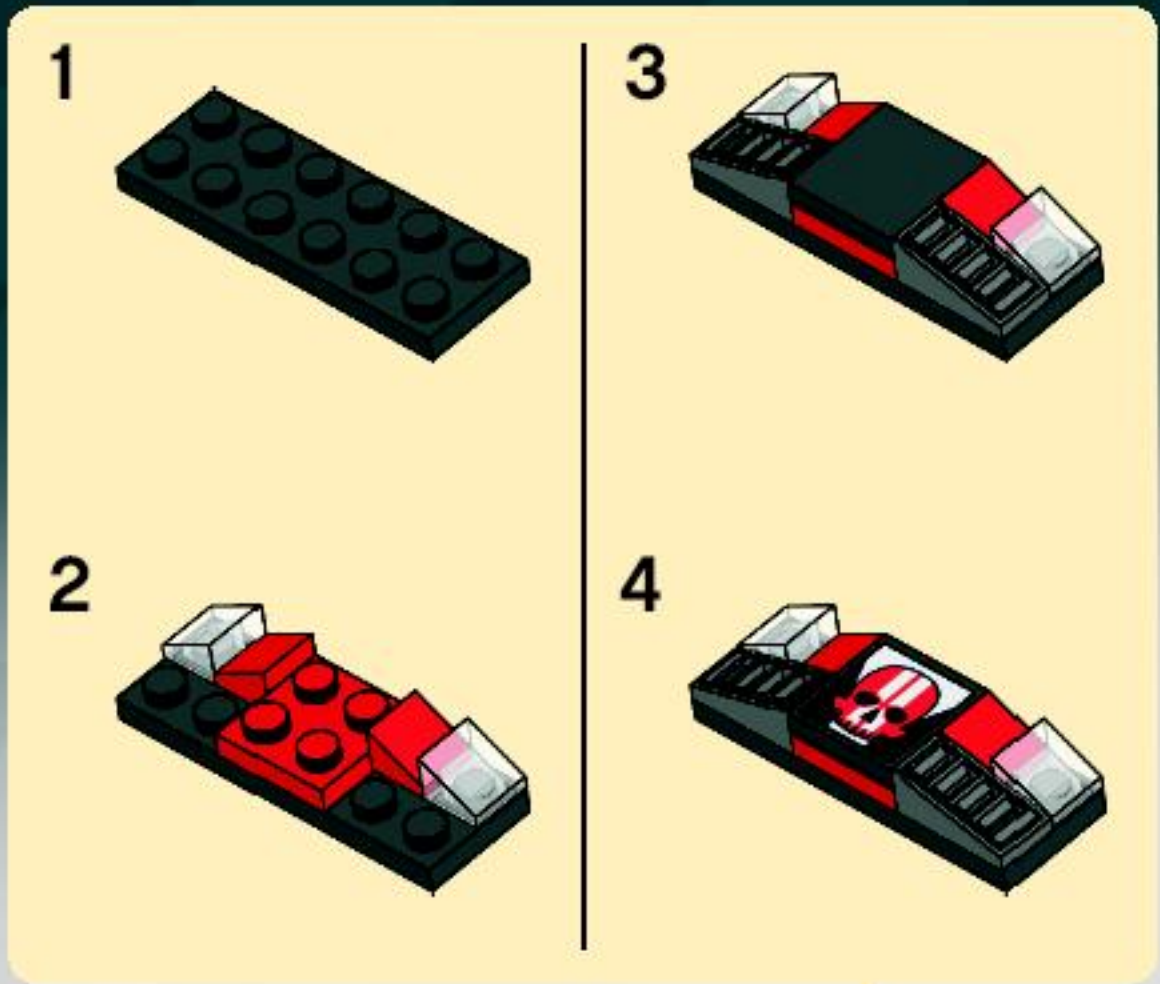
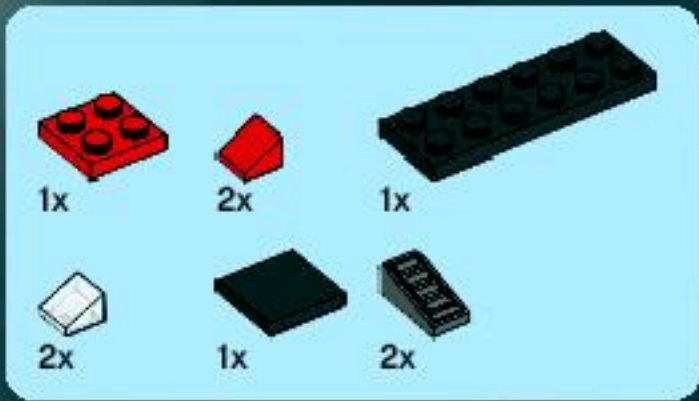

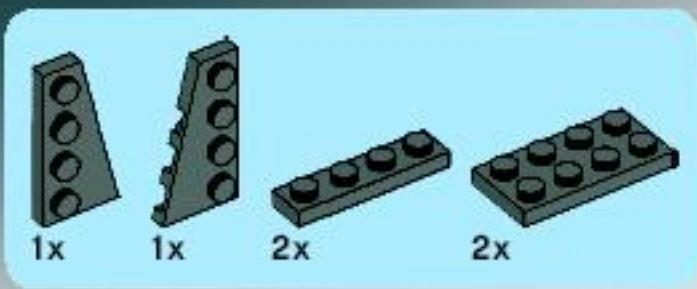

12

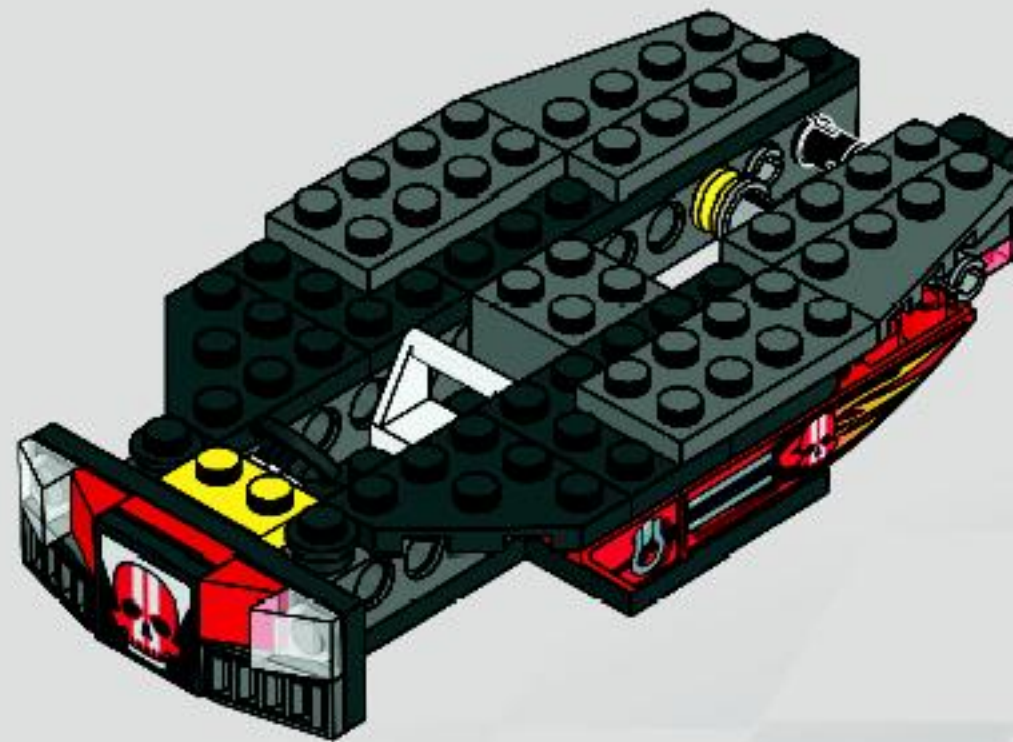



2x

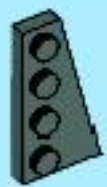

1x



1x

13

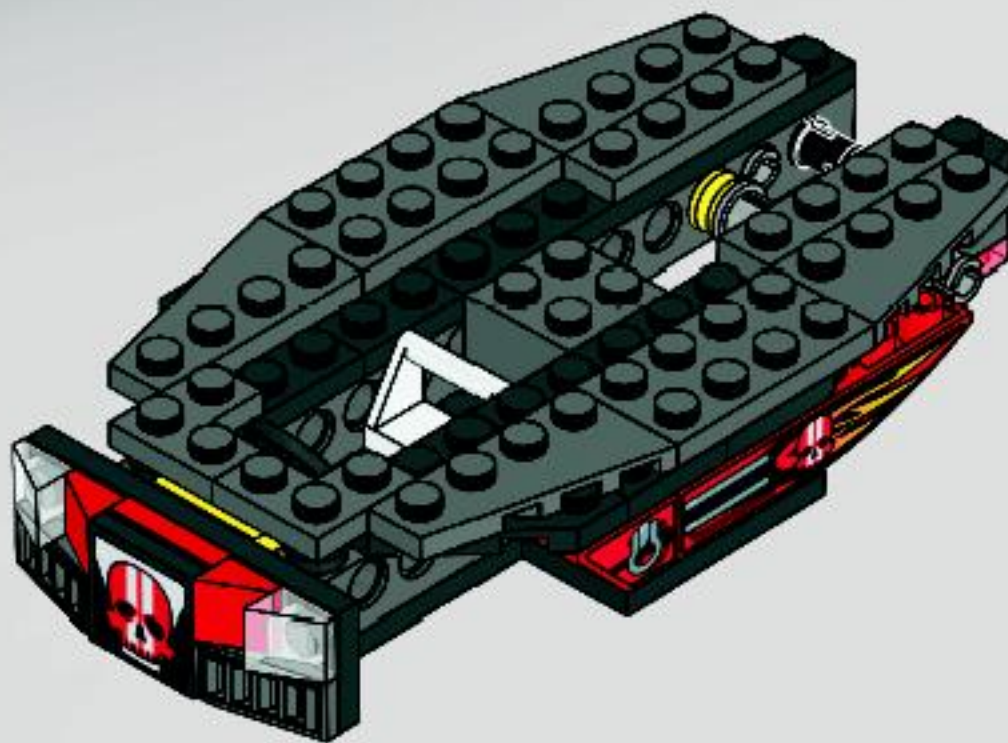



14

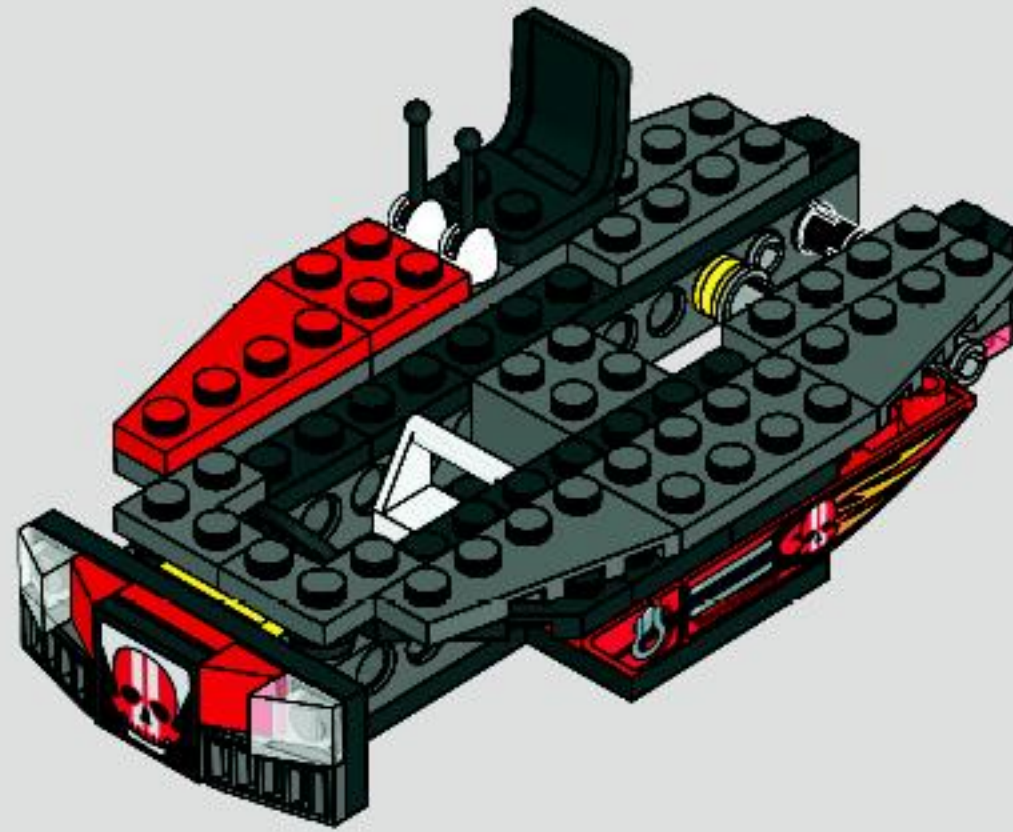

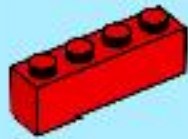

1x



1x



2x

15

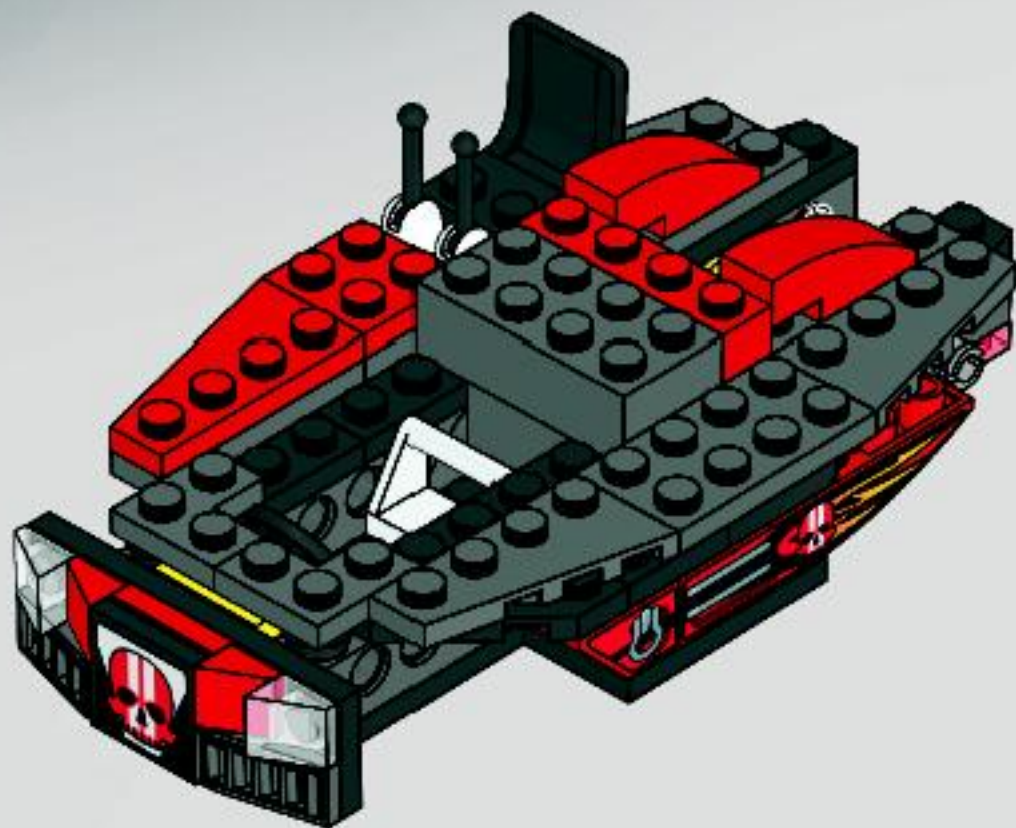



2x

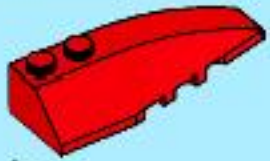

1x



2x

16

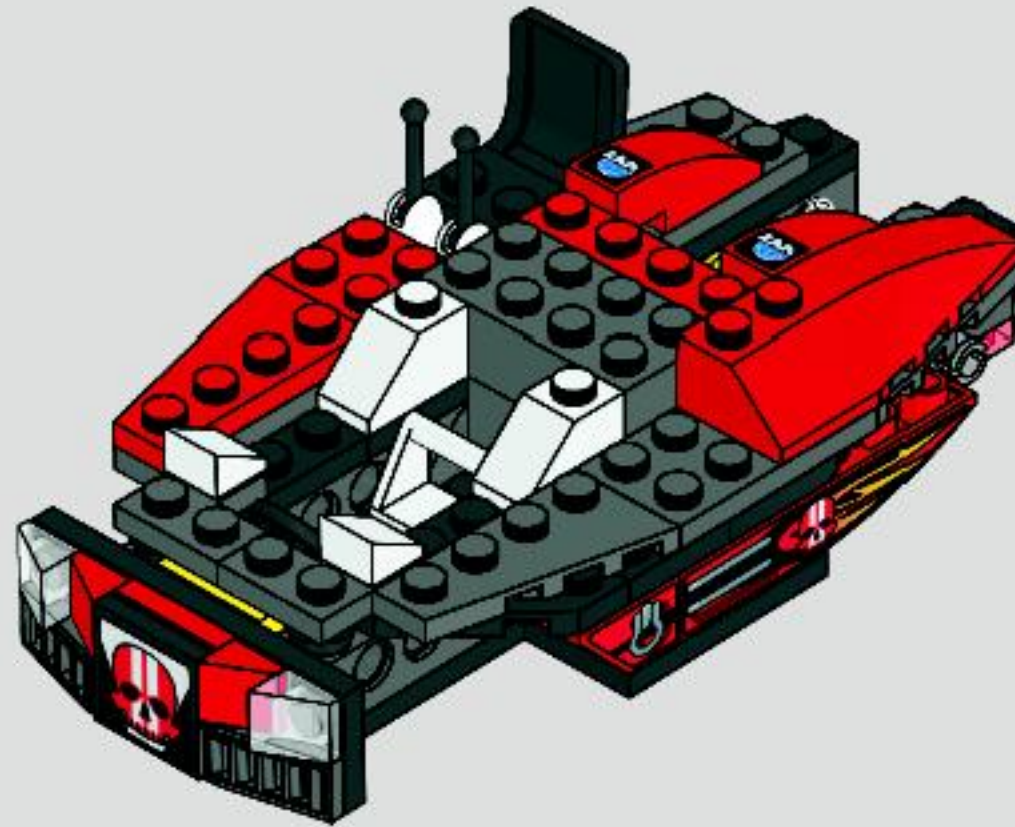

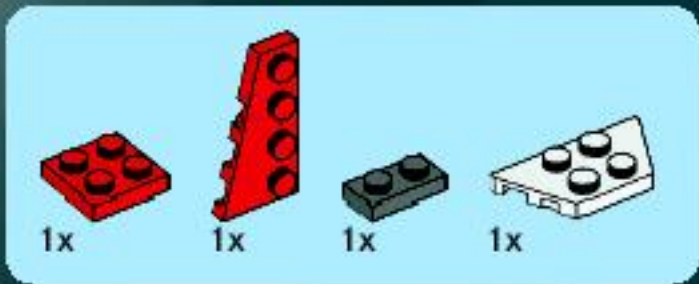

17

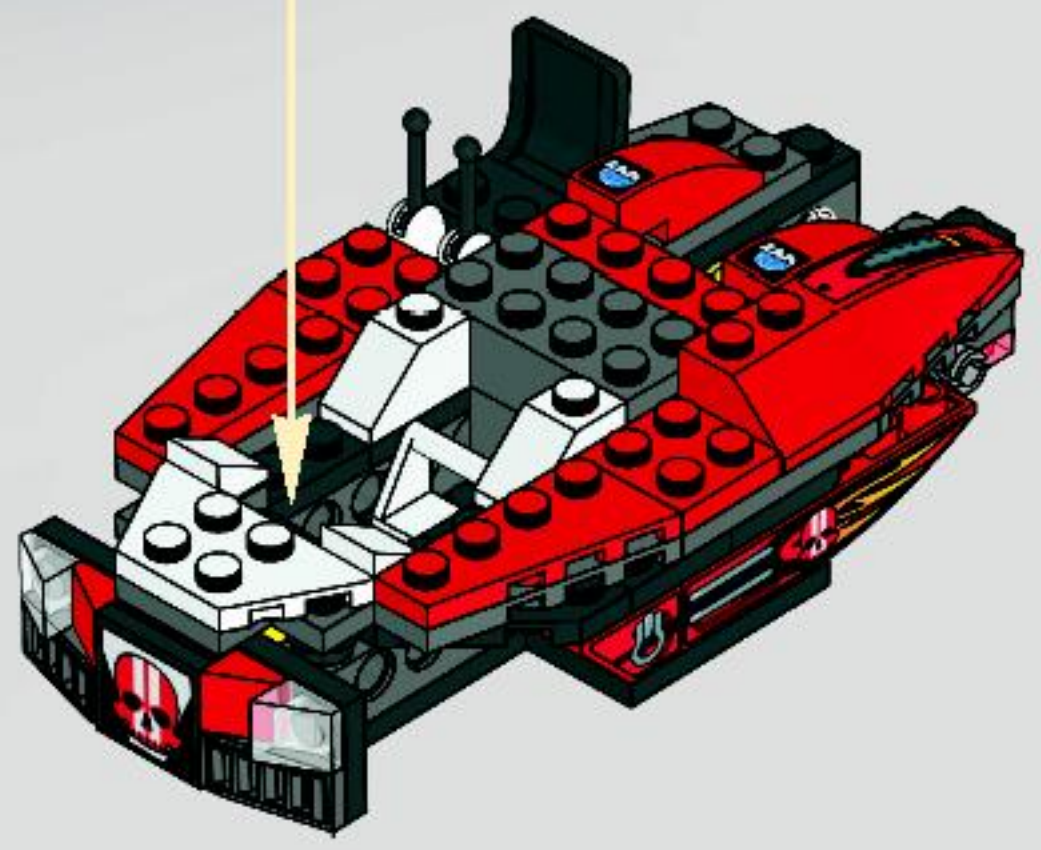
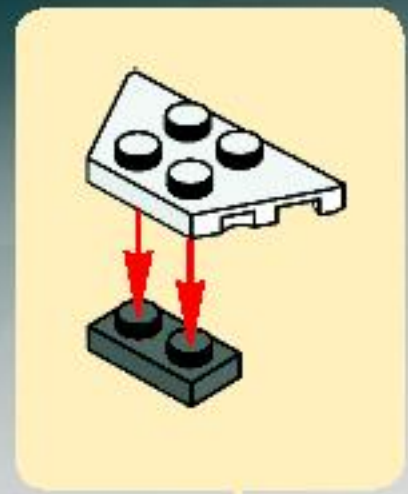

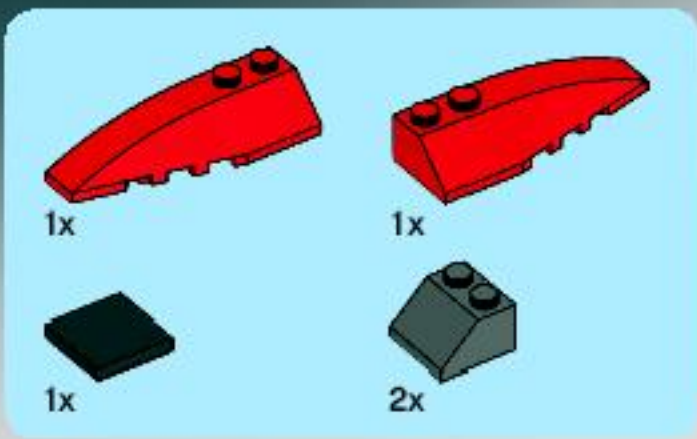

18

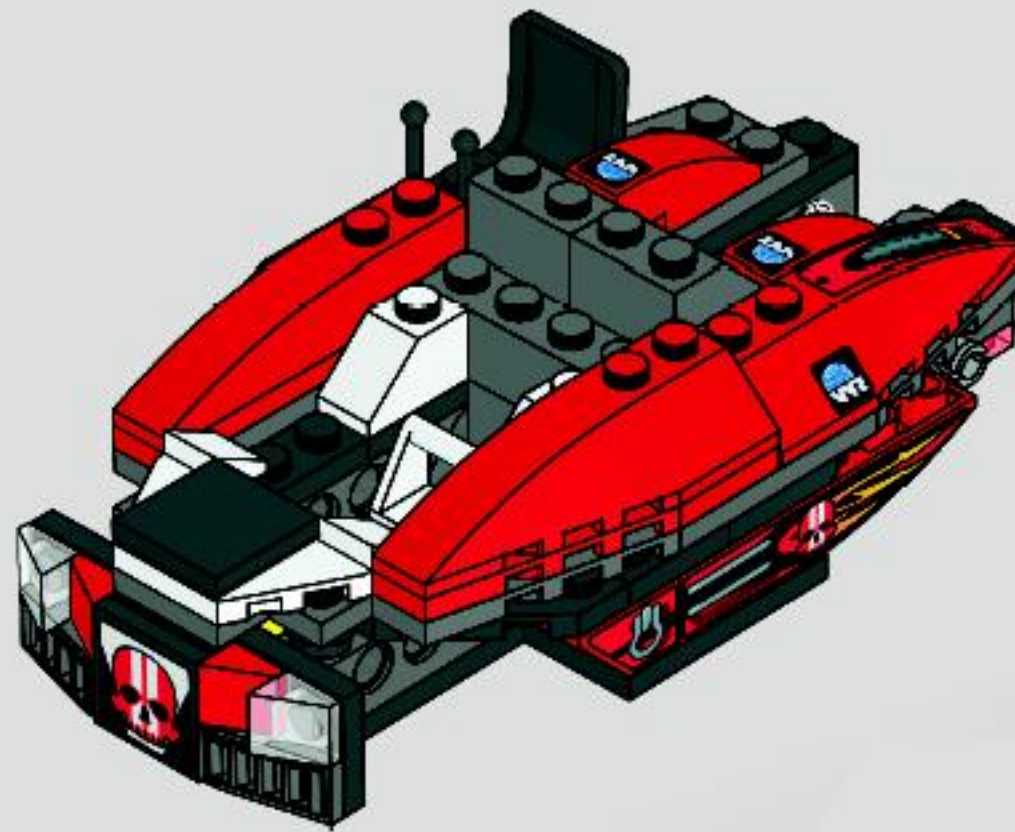



2x



1x



1x

19

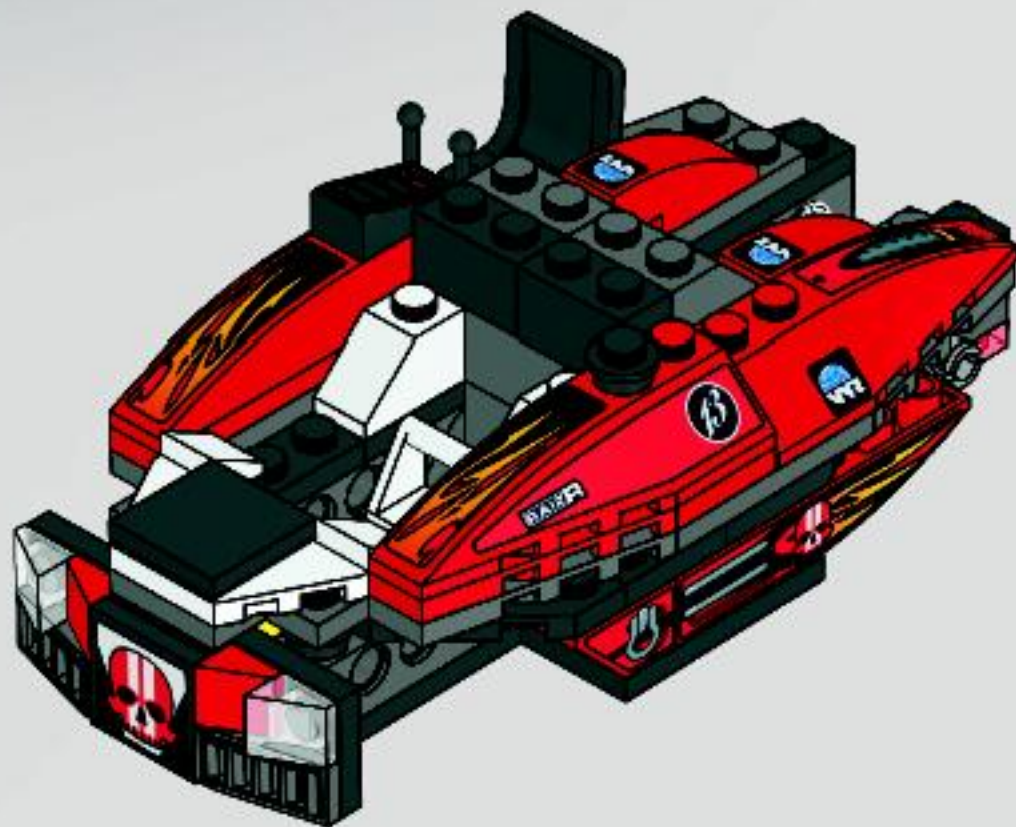

2x 1x 1x

20

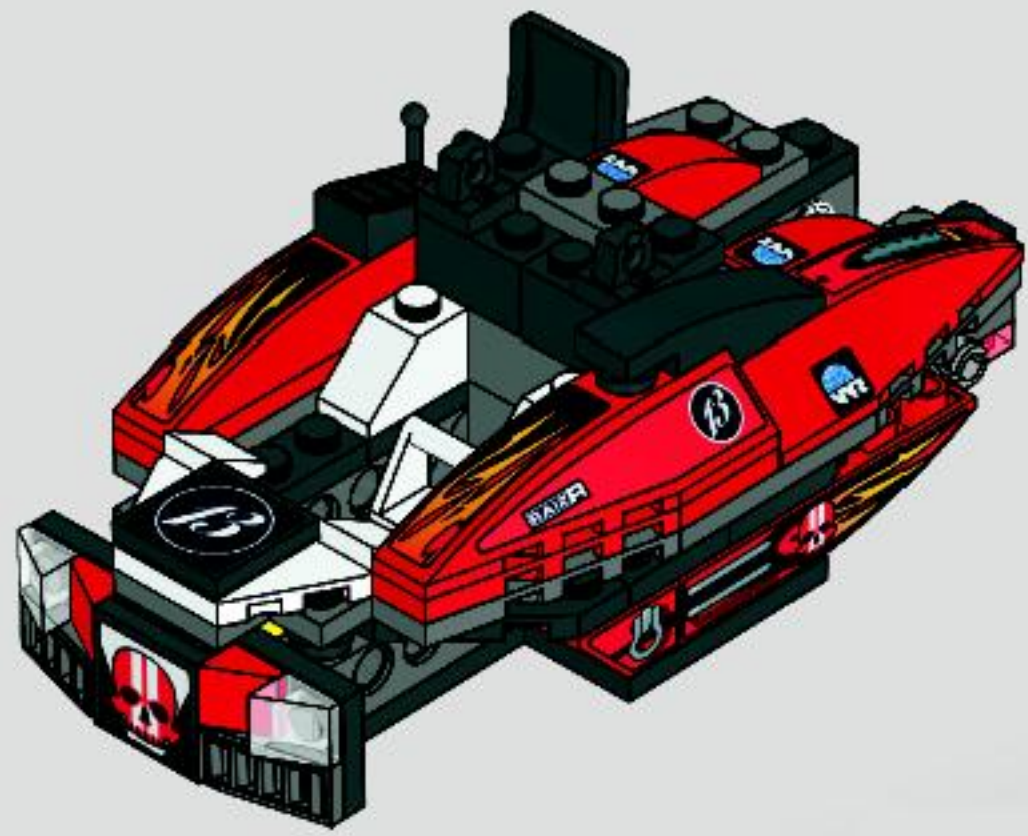



1x

21

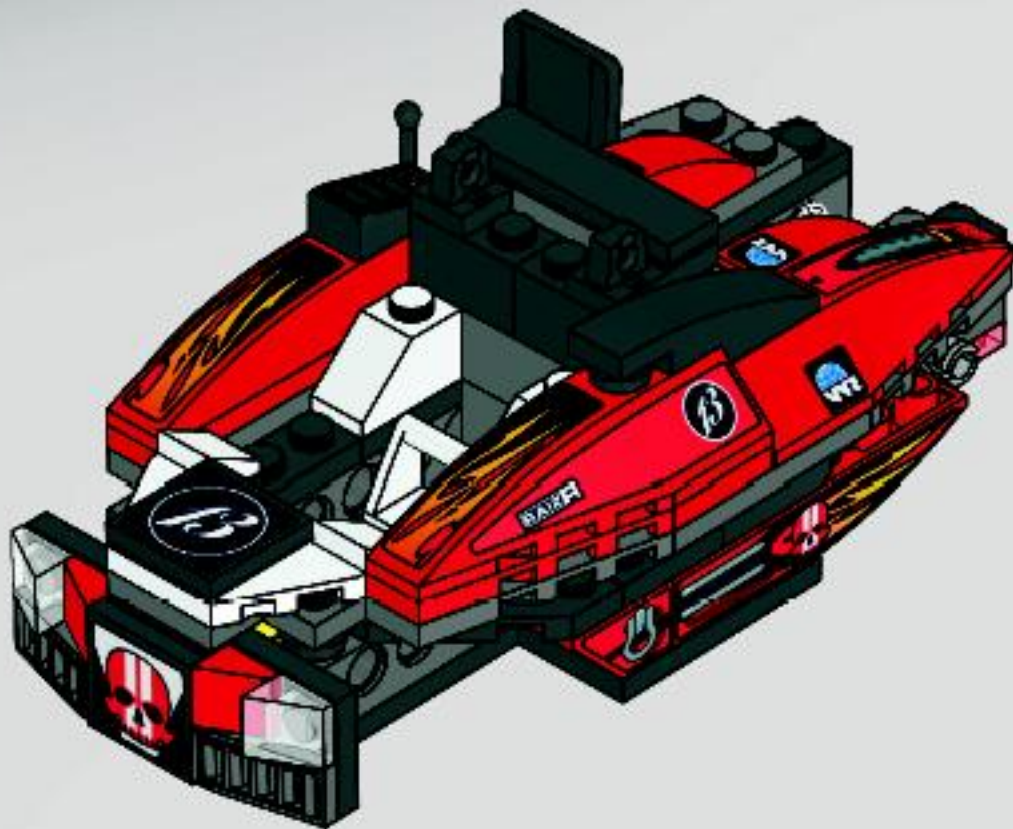

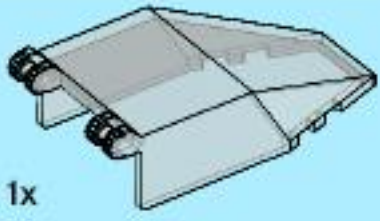

1x

22

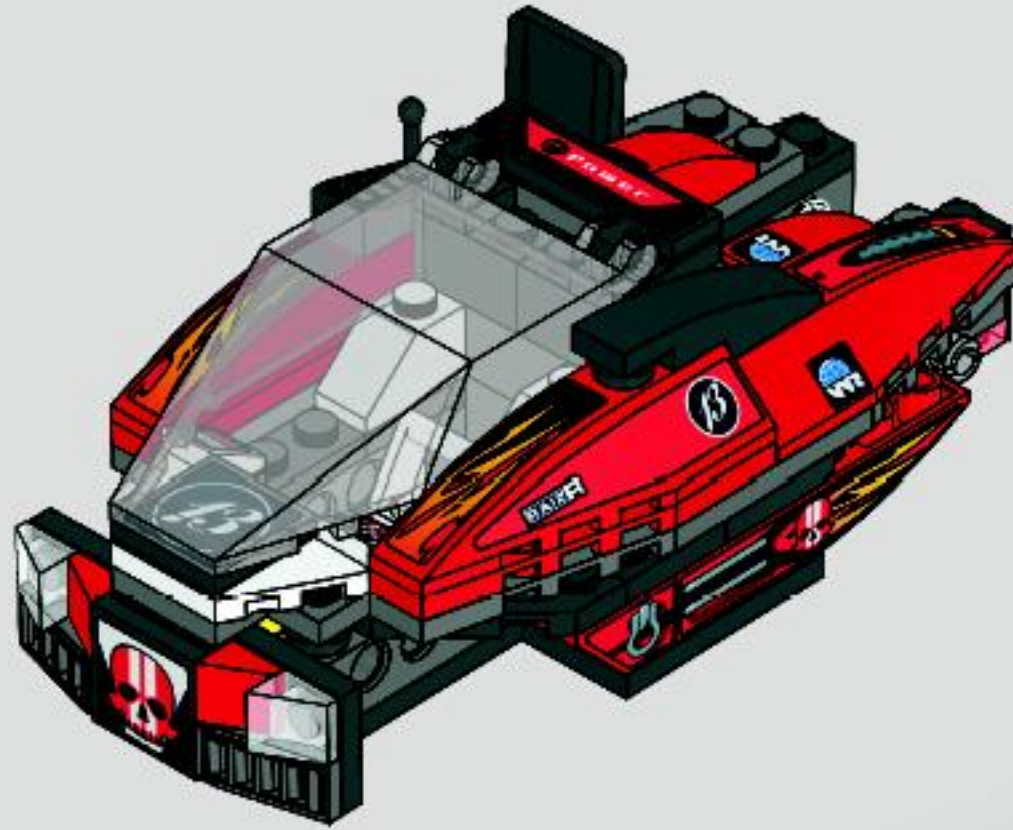

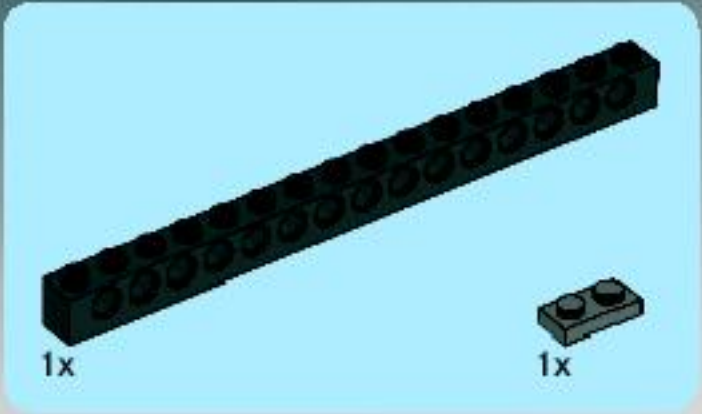
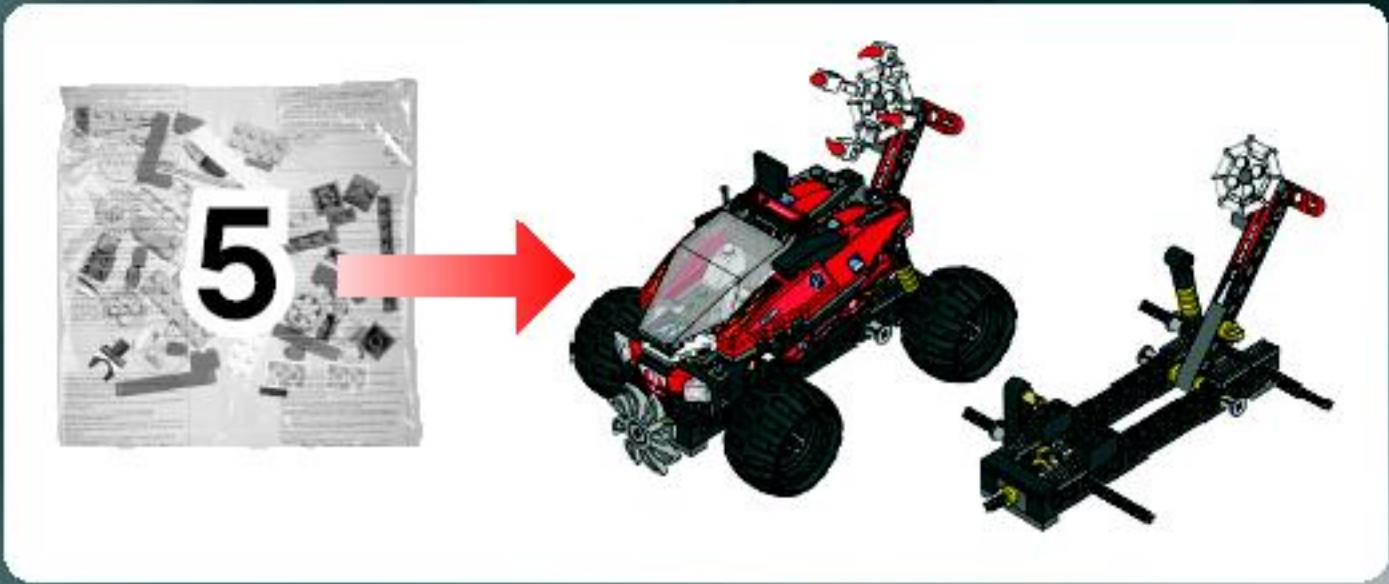

1

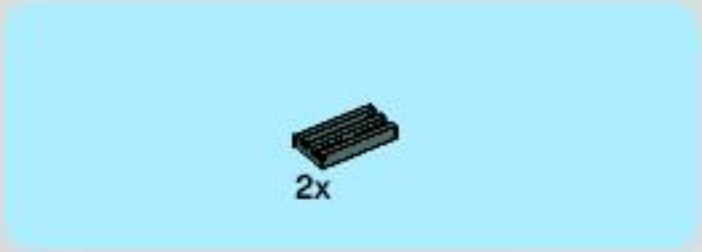

2

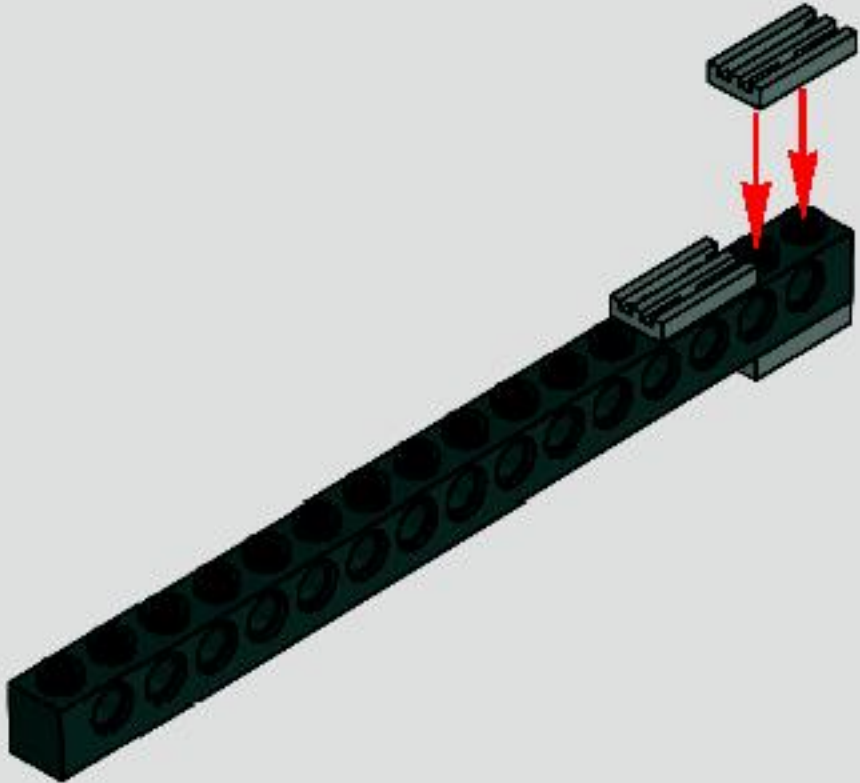

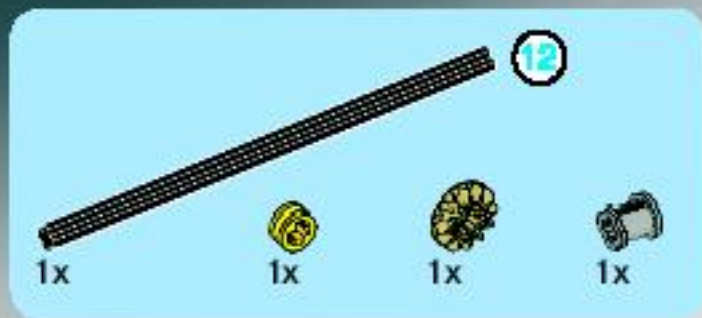

3

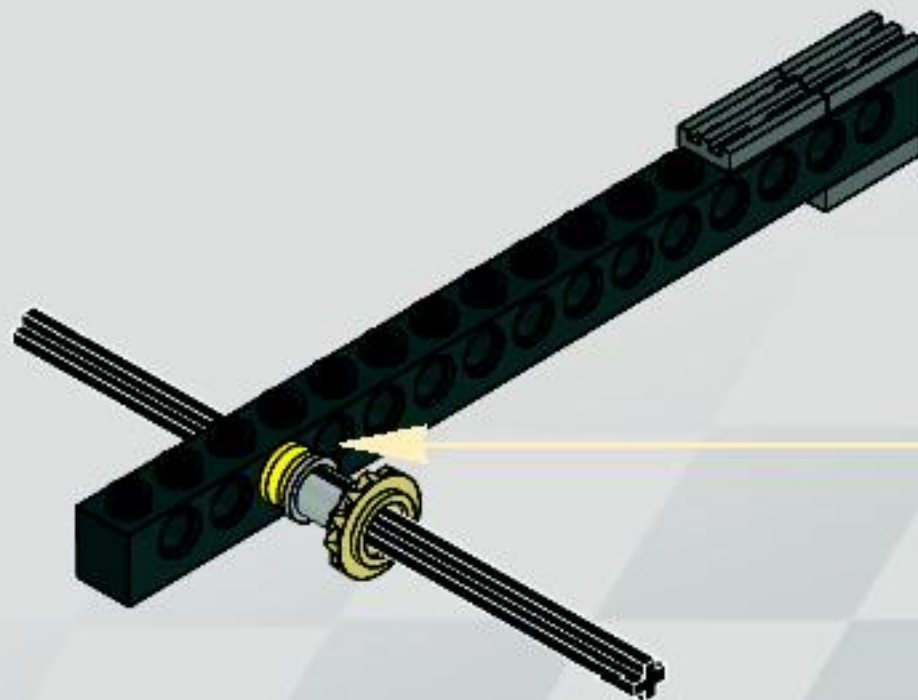
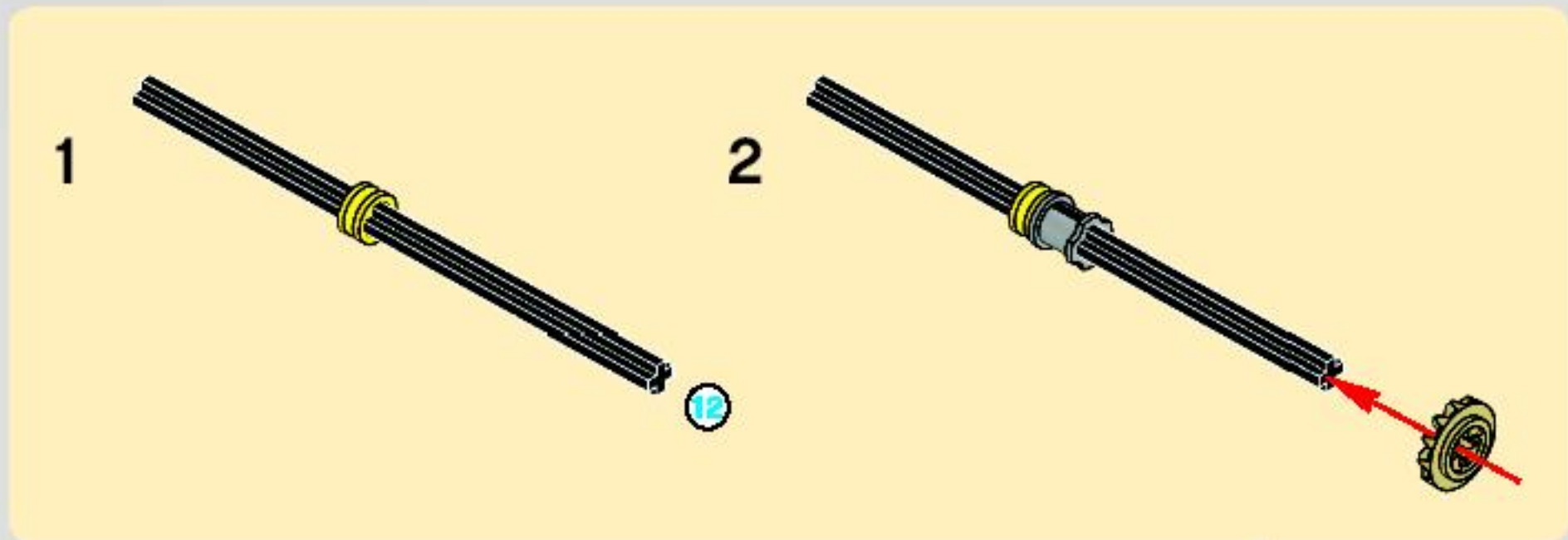

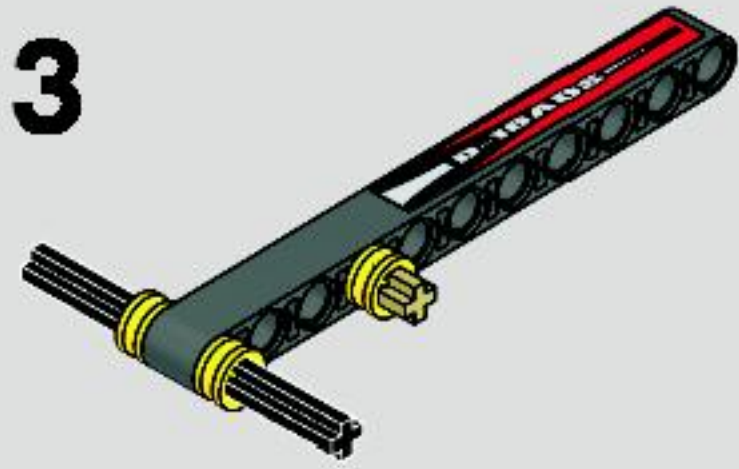
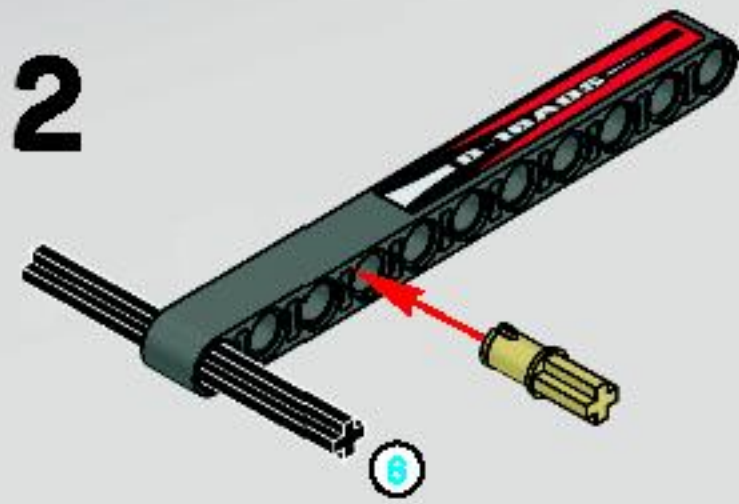
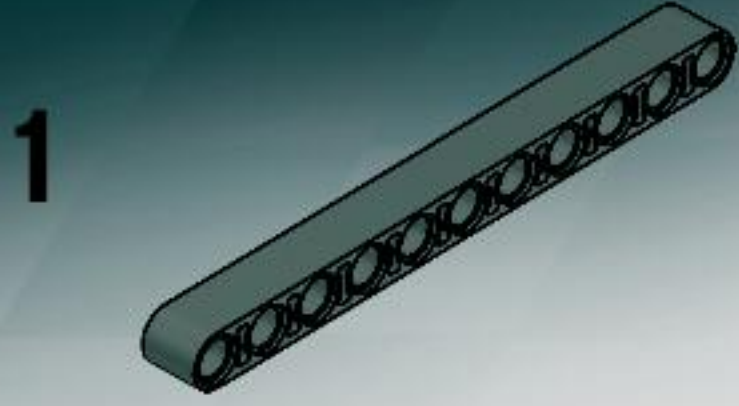
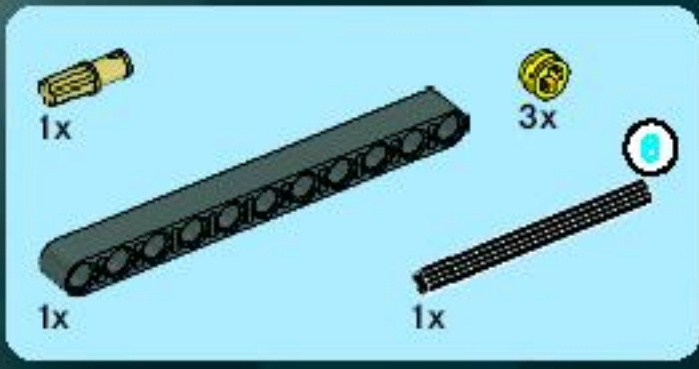

4

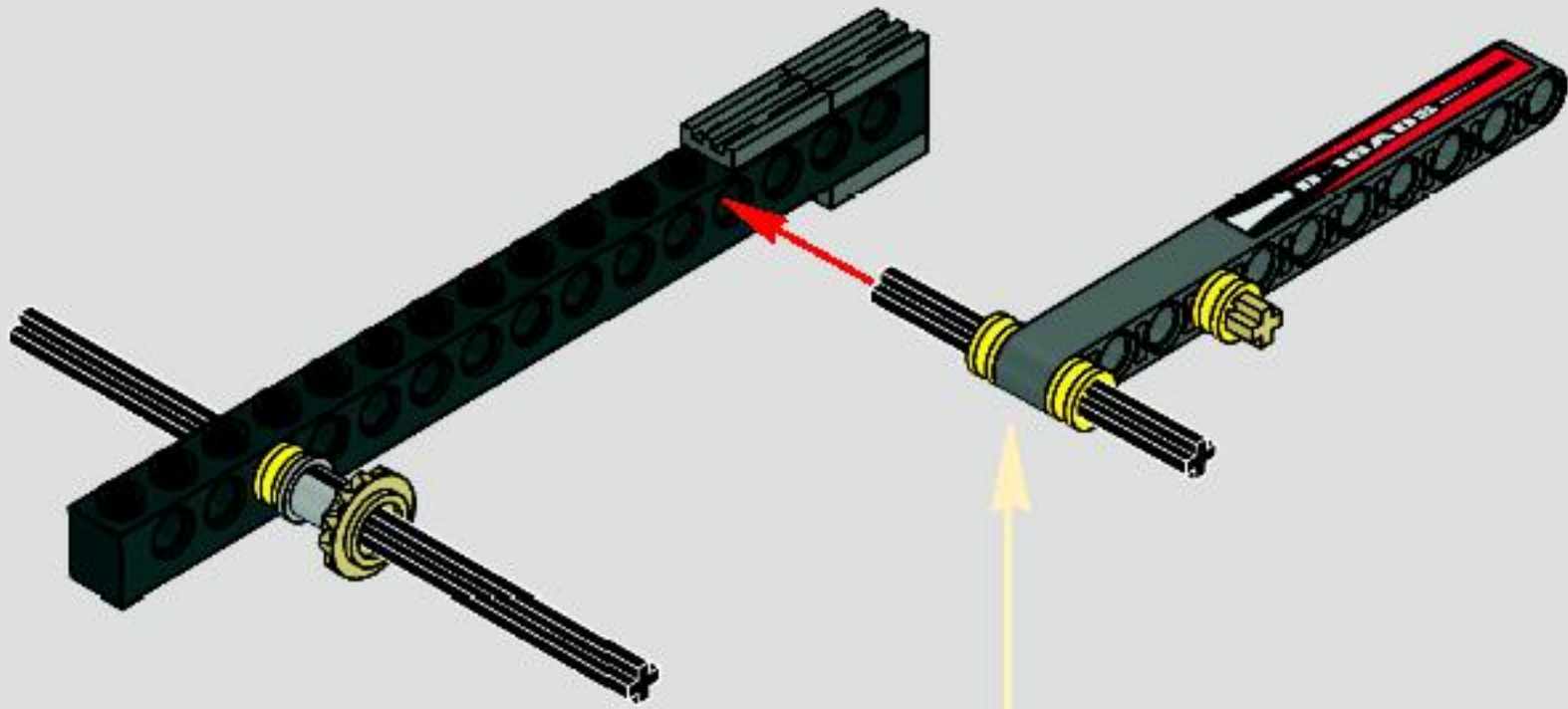

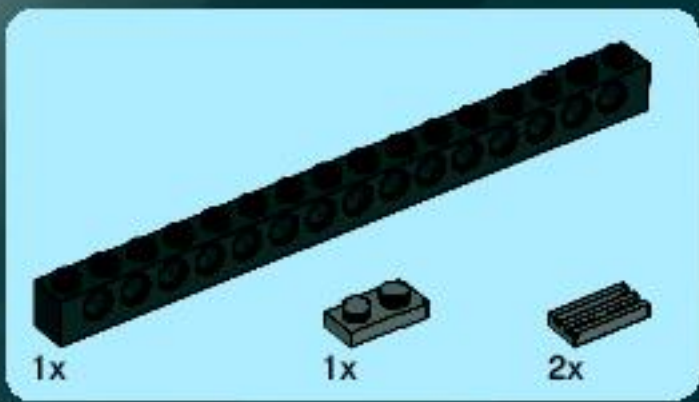

5

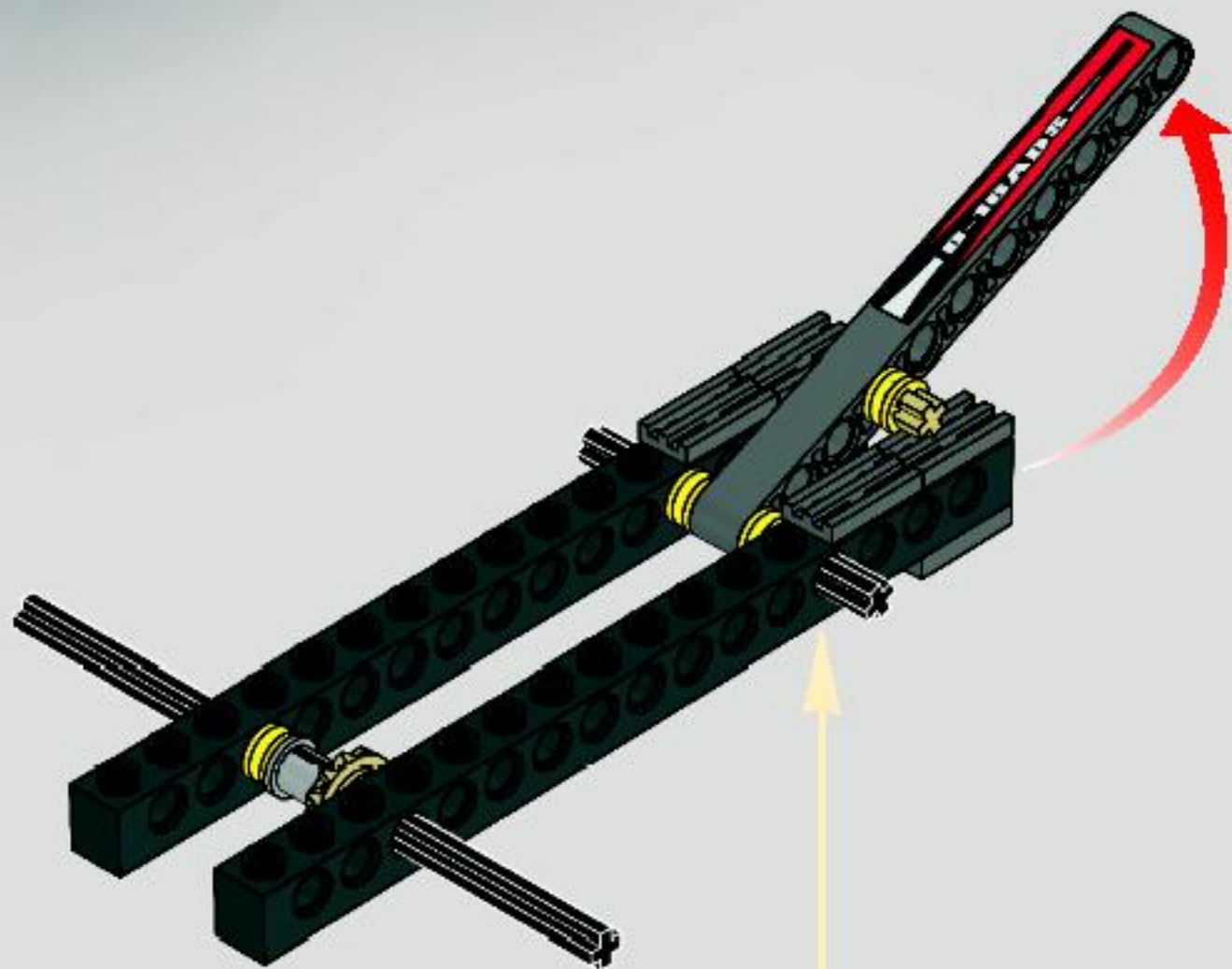
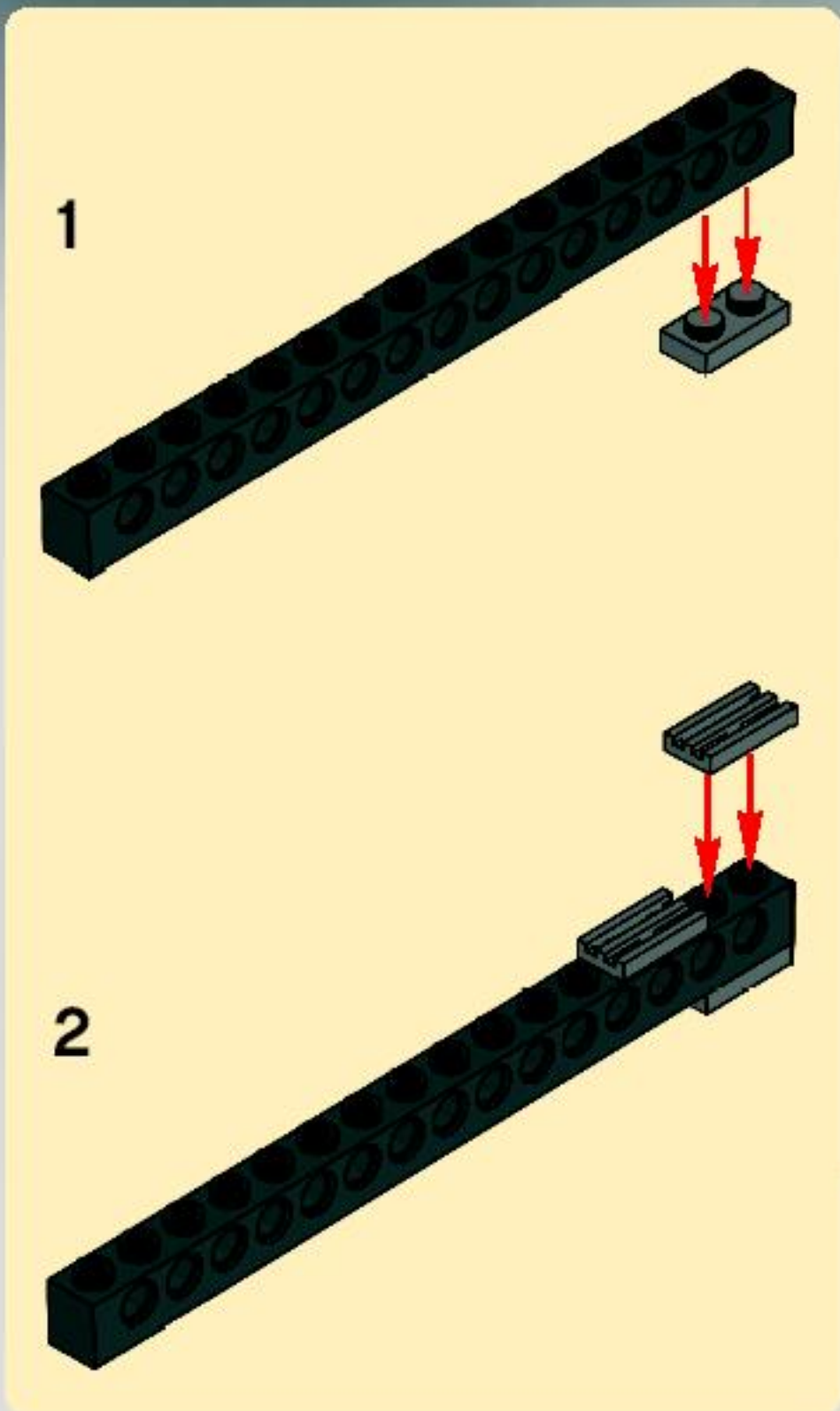



1x



2x

6

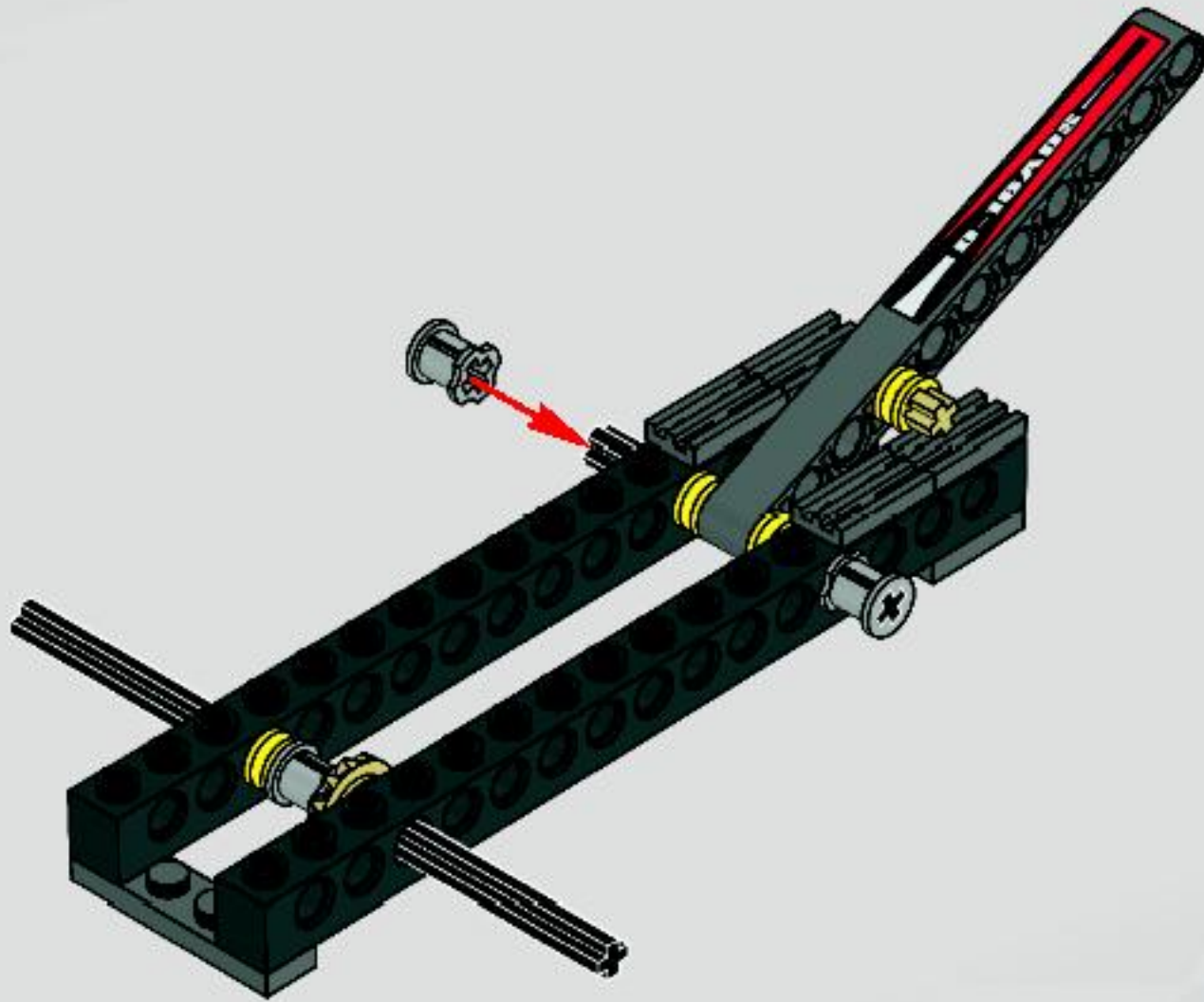

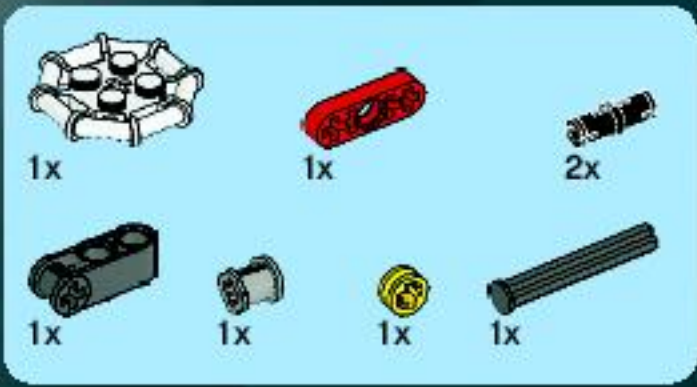

7

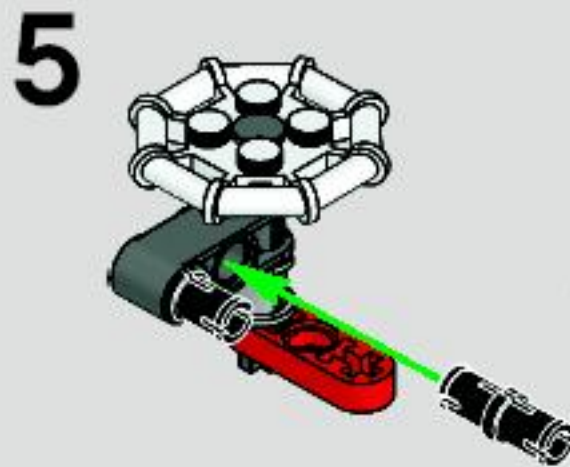
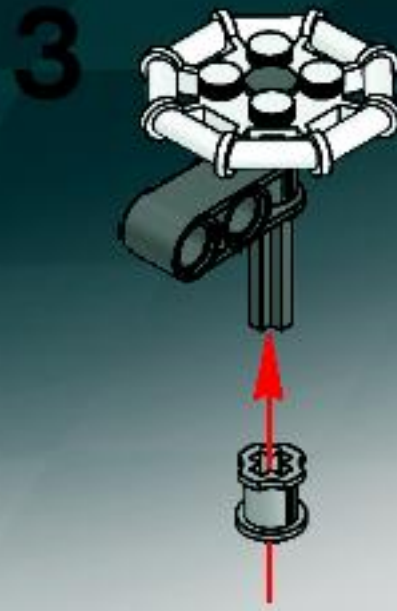
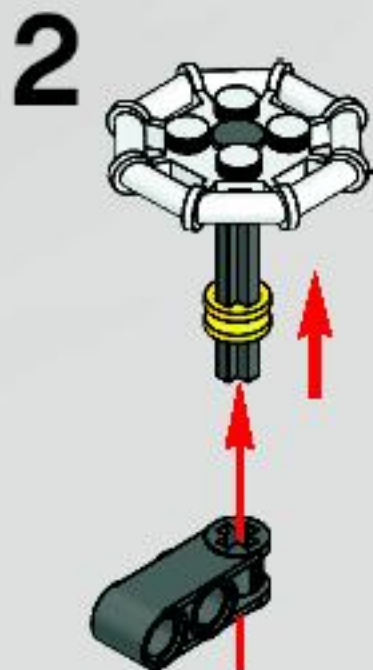
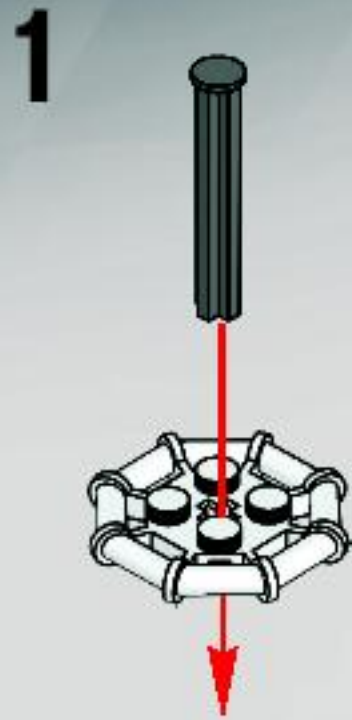

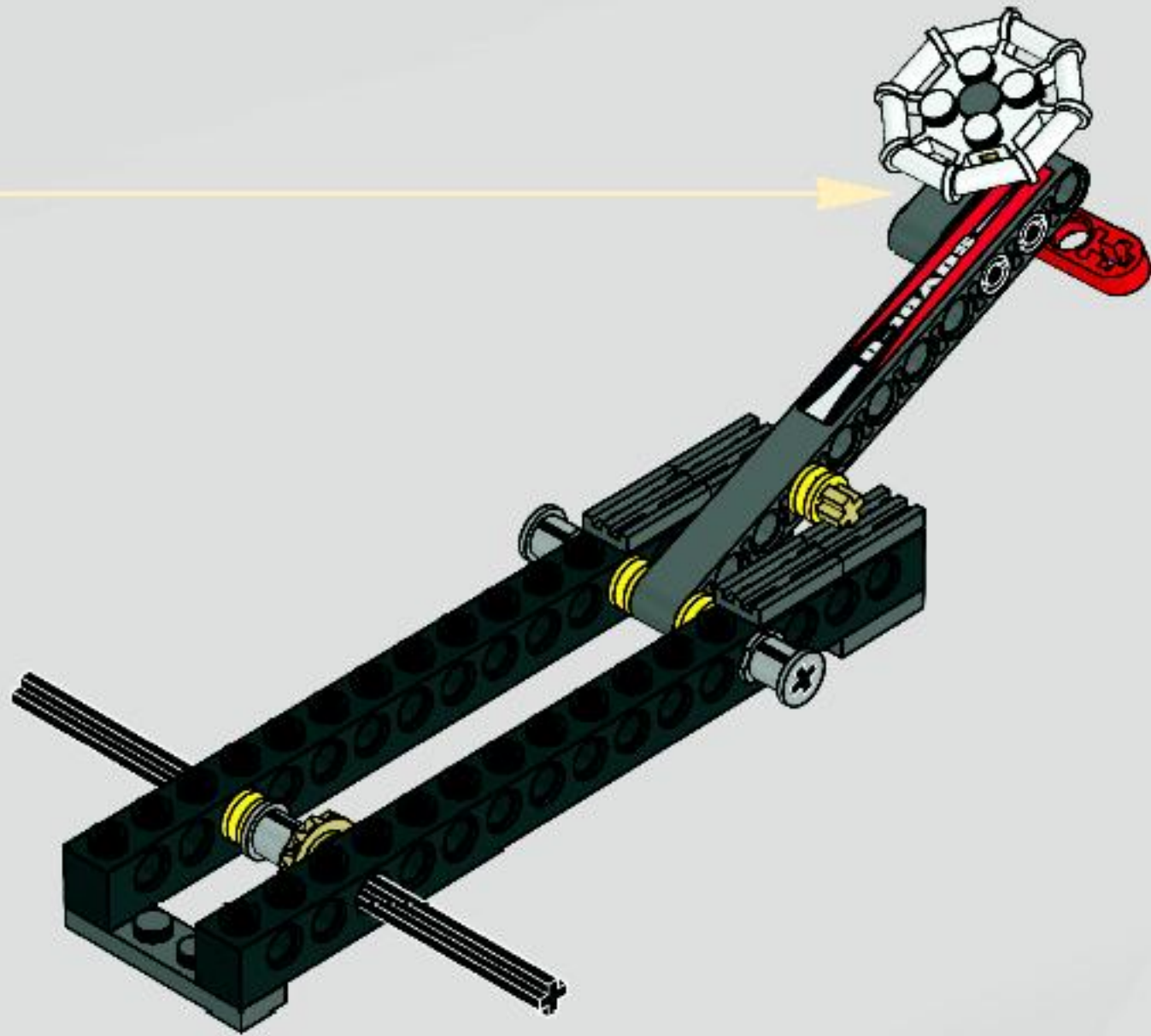

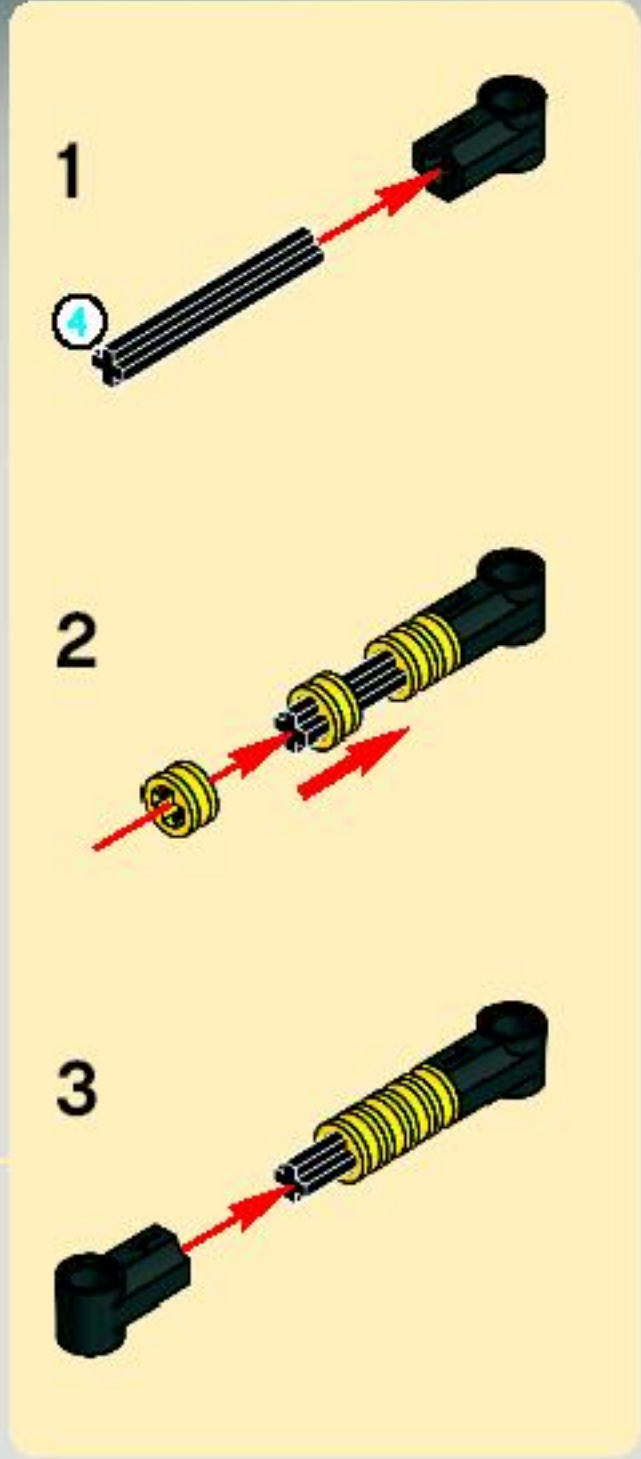
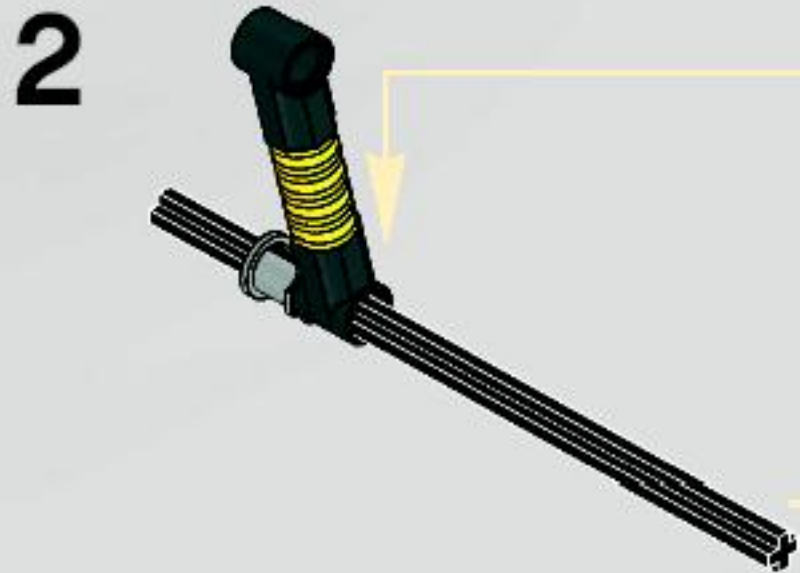
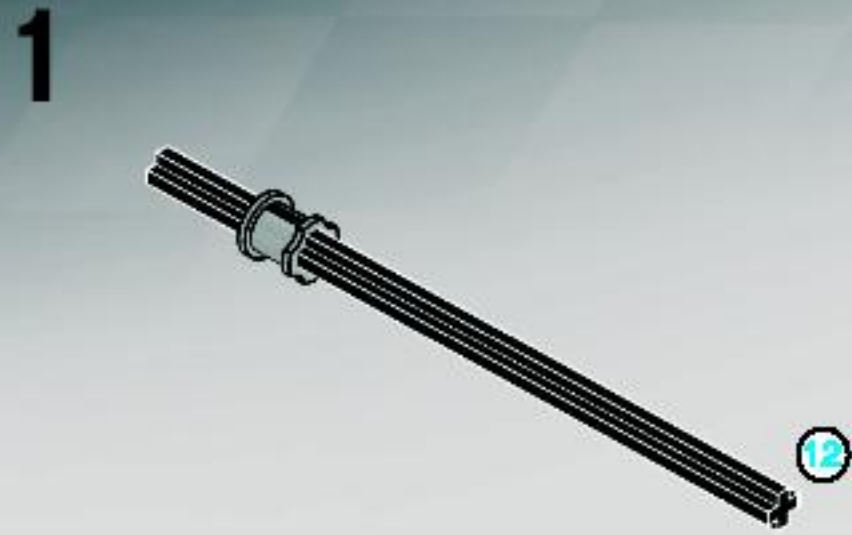
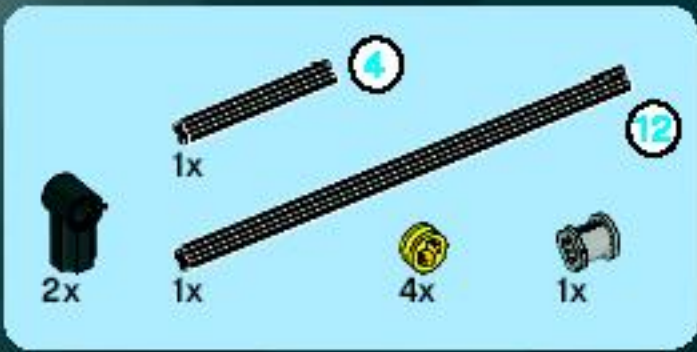

8



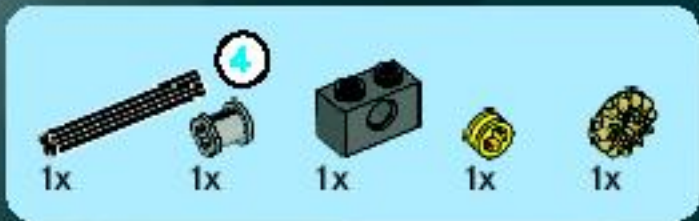

9

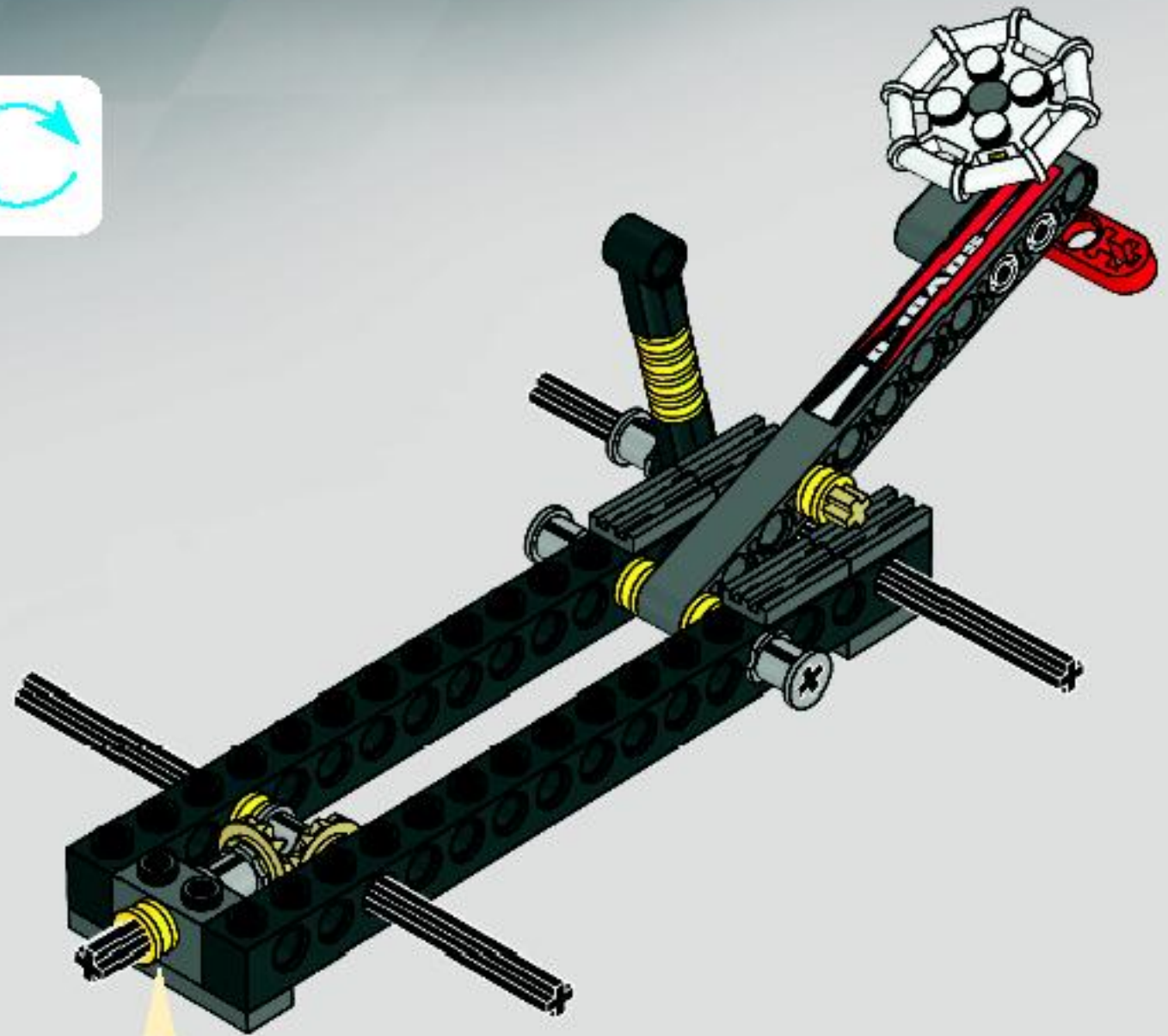
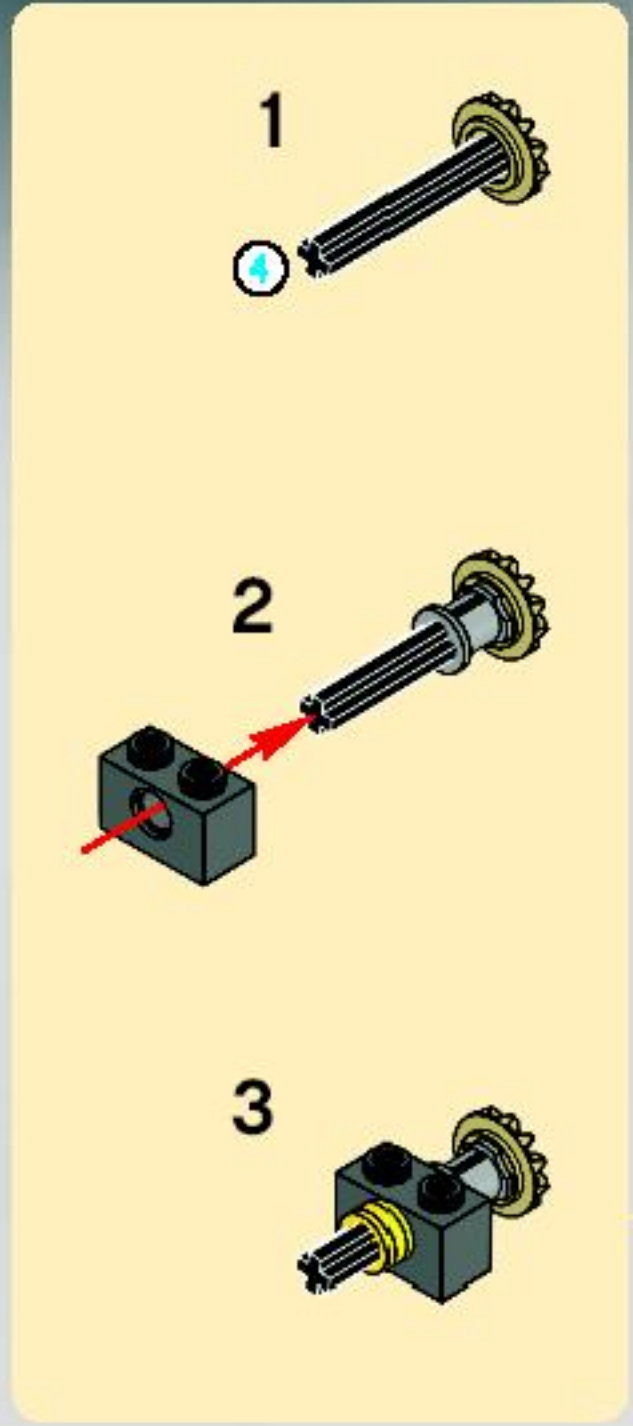



10

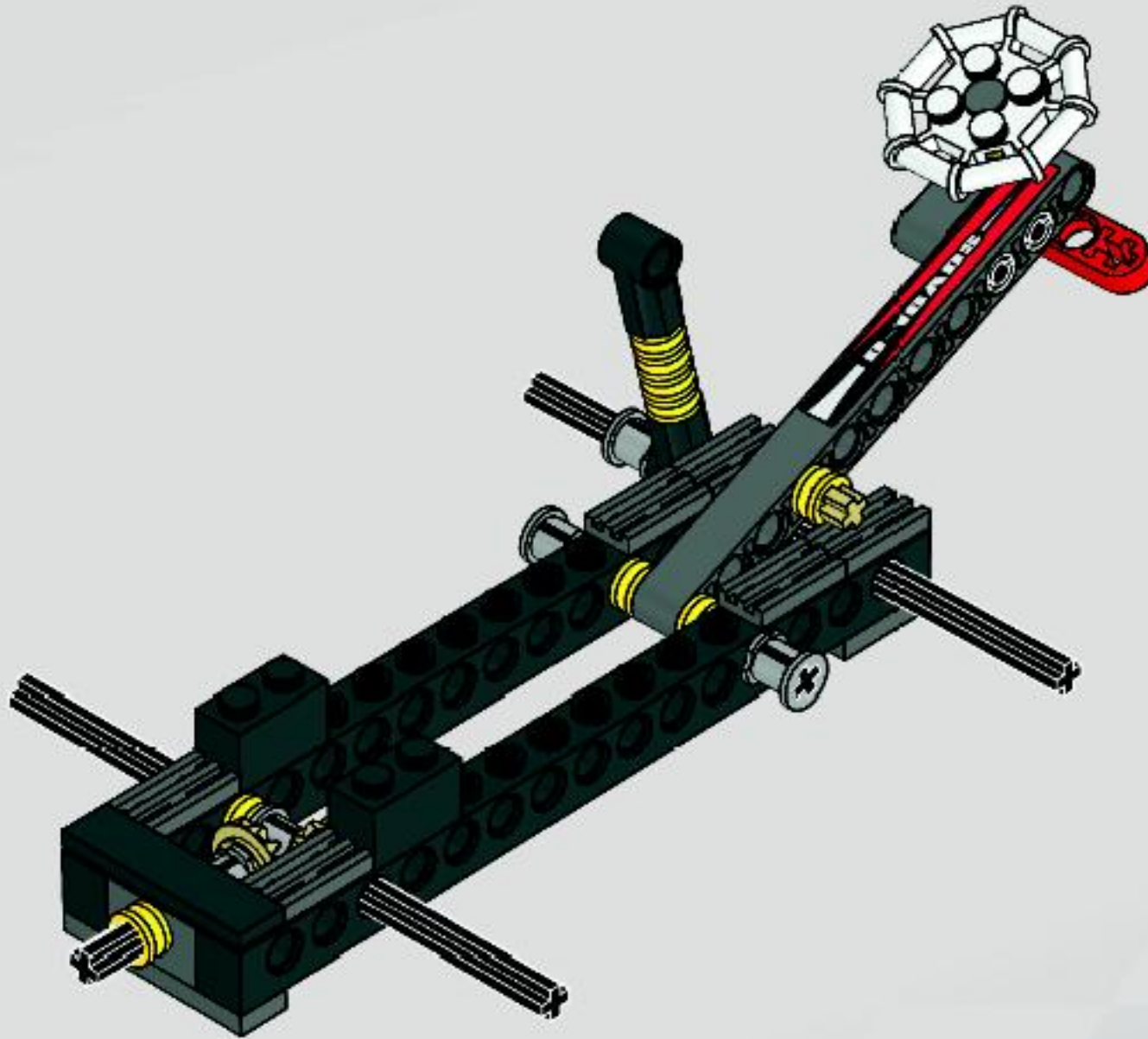



11

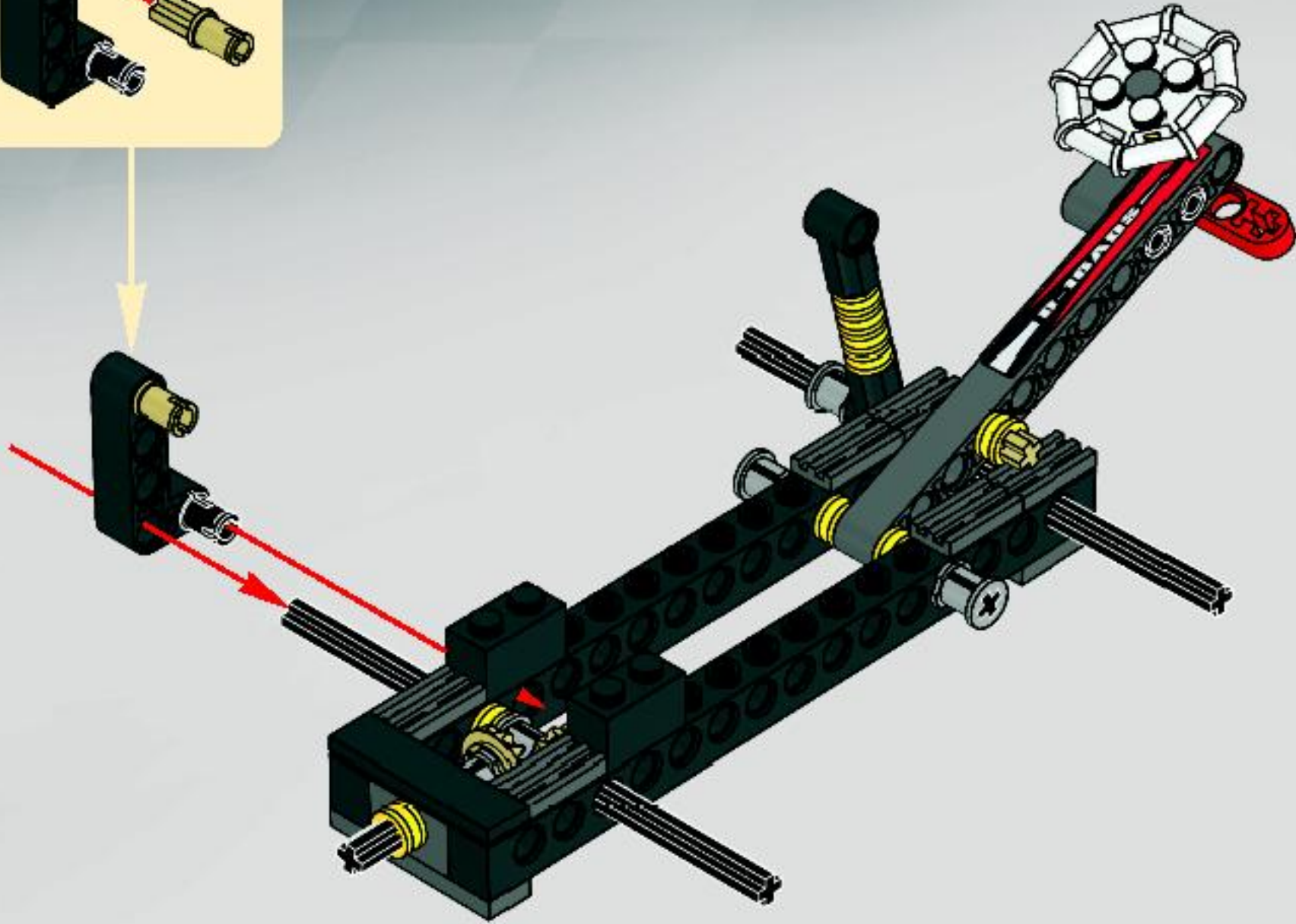
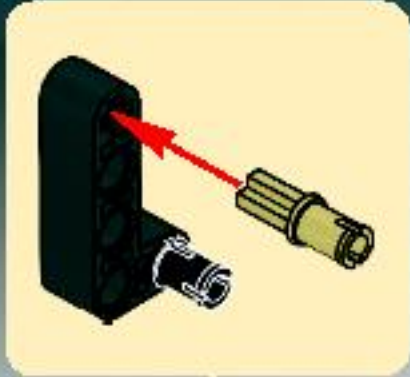



1x

12

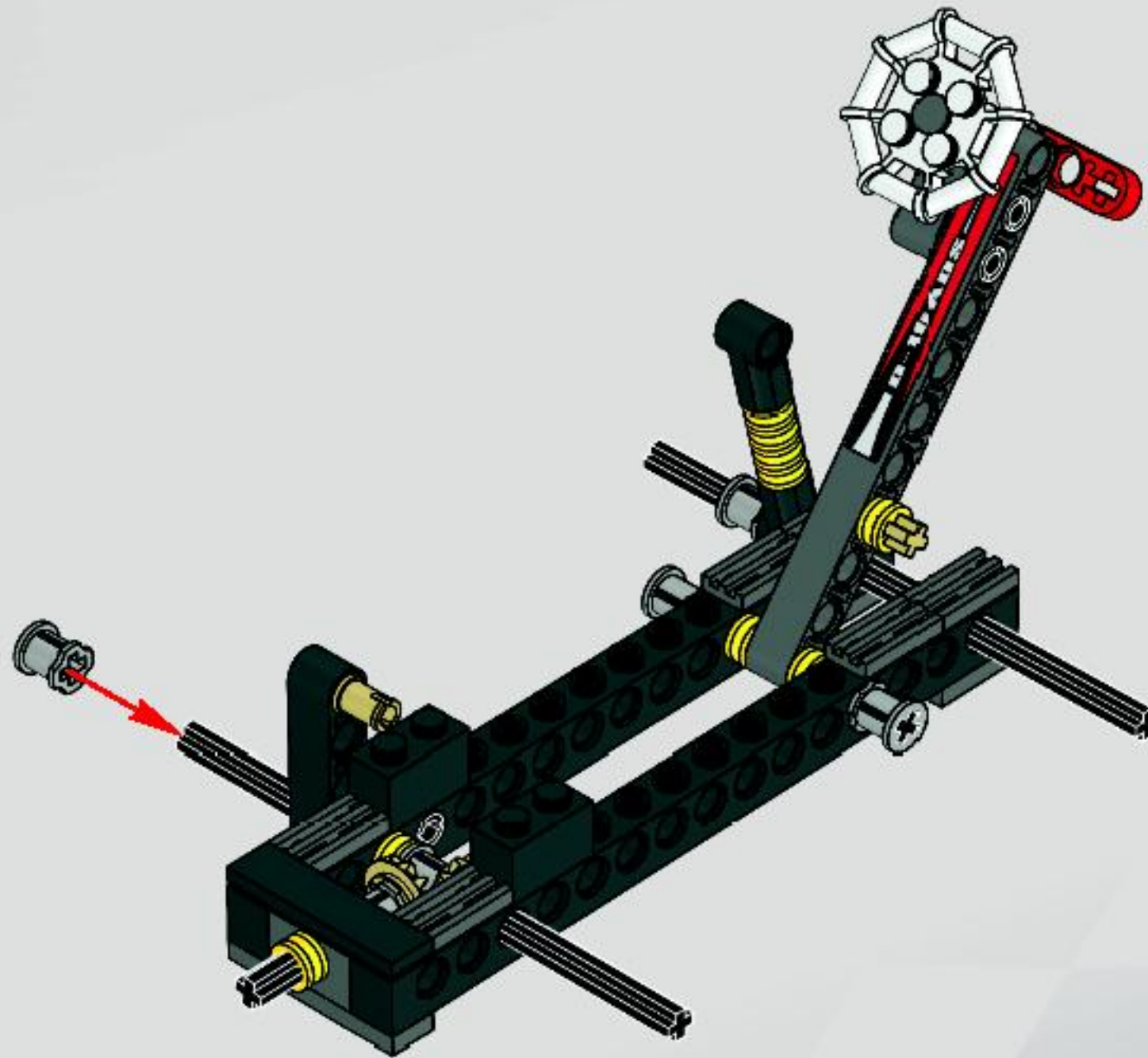

23

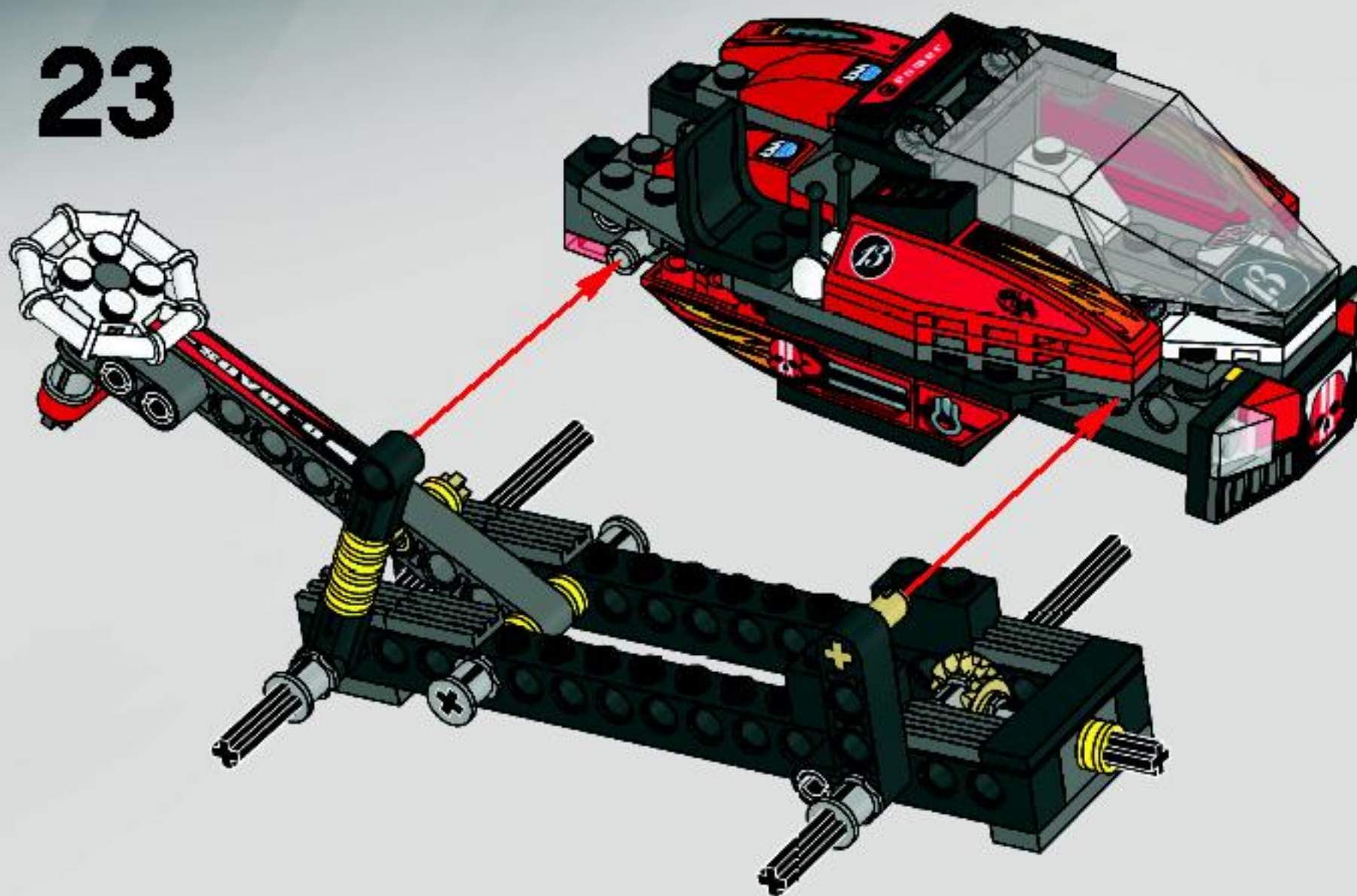

24

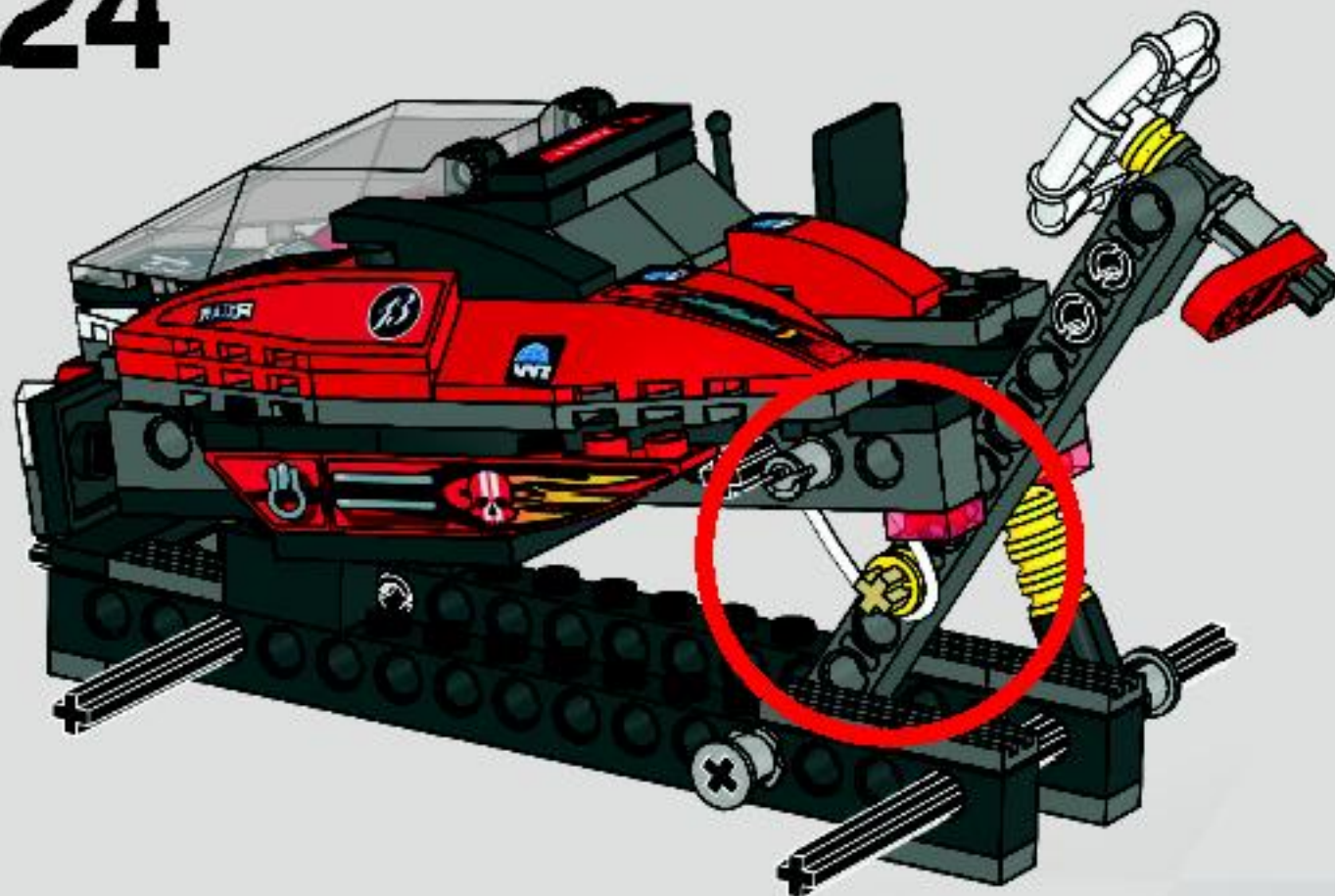



25

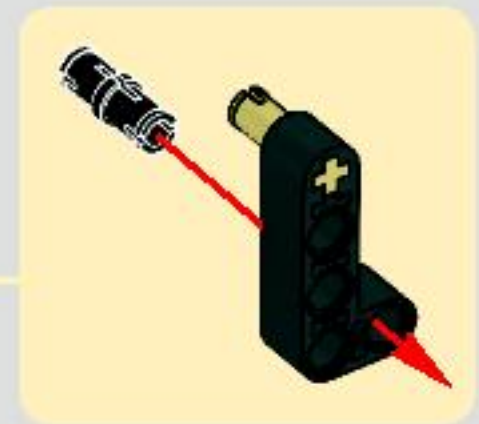
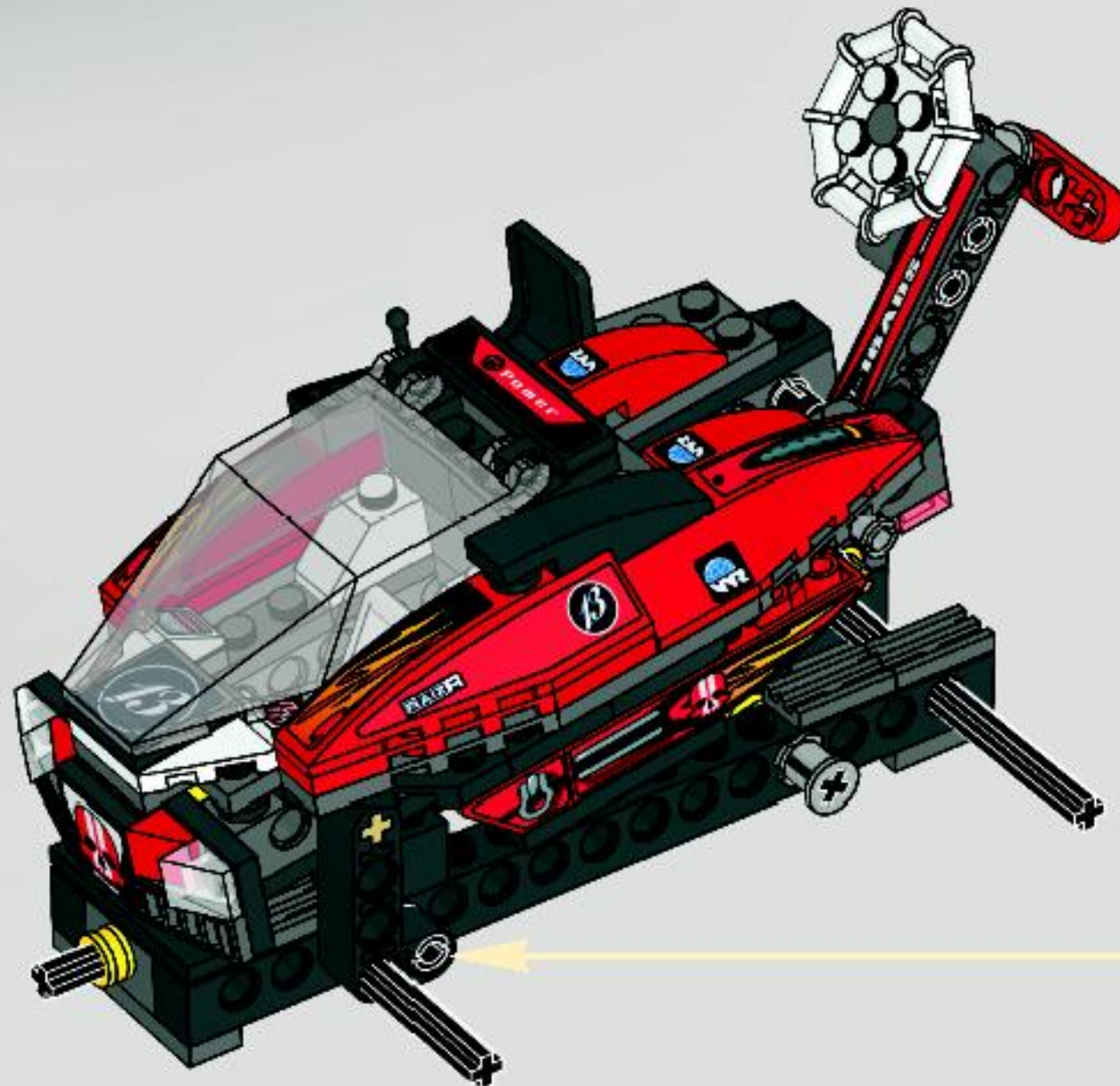

1x  2x  4x 

 1:1

26

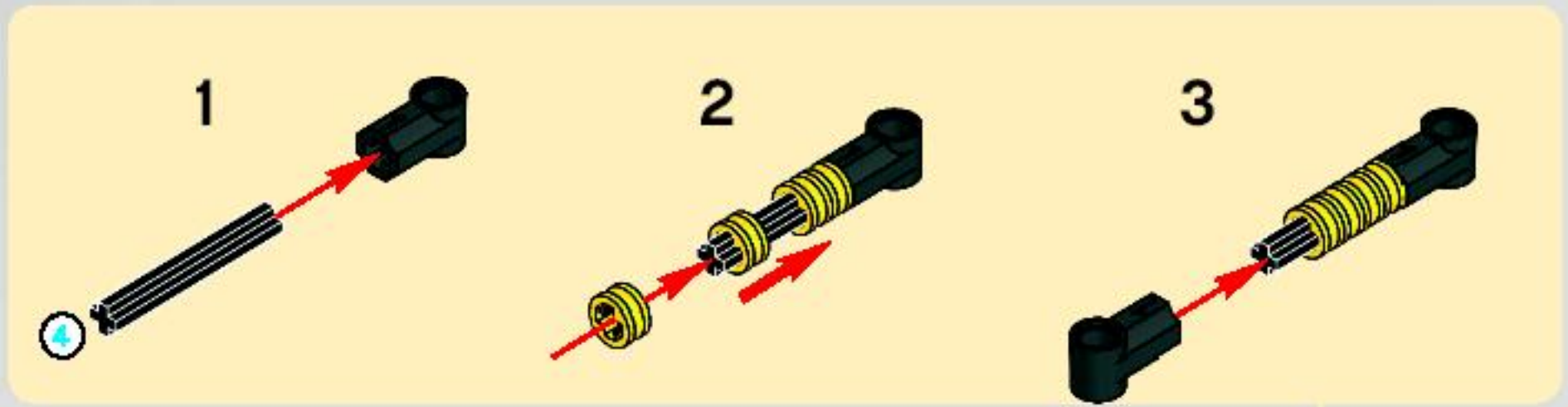



1x



2x

27



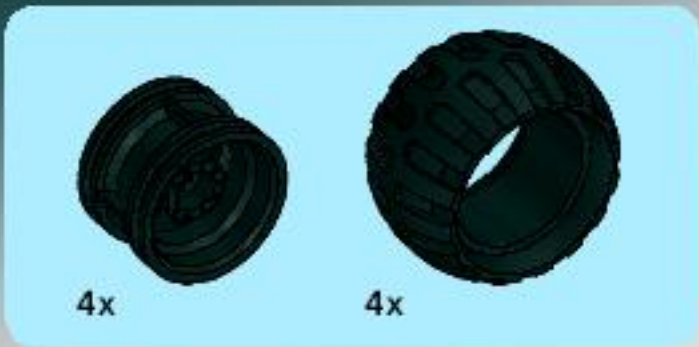

28

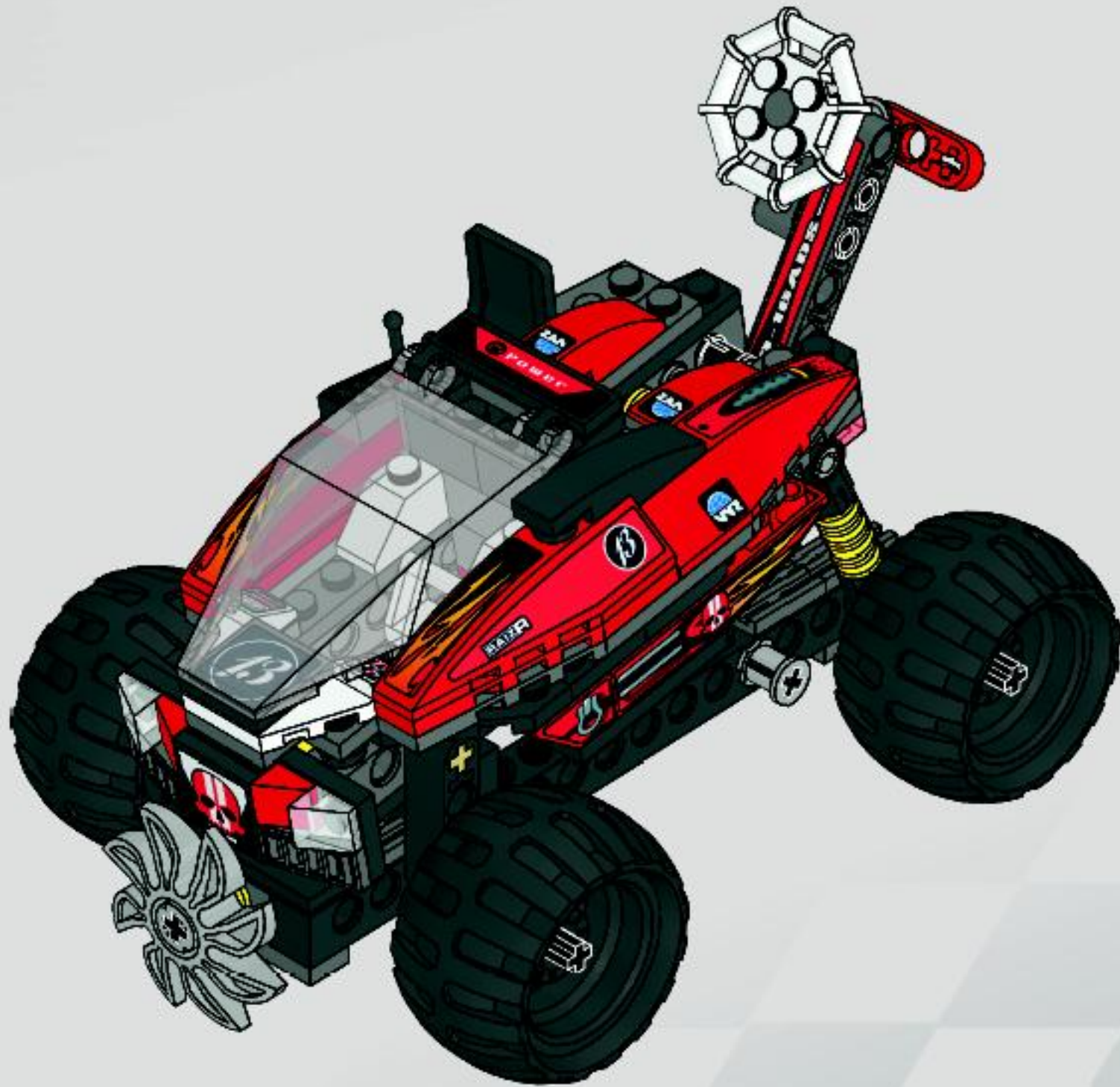



4x



4x

29

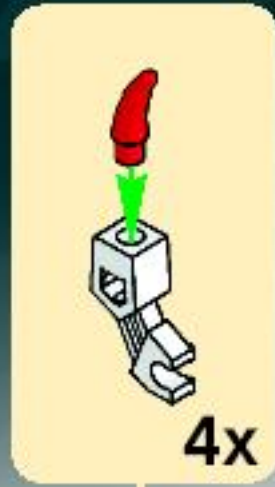

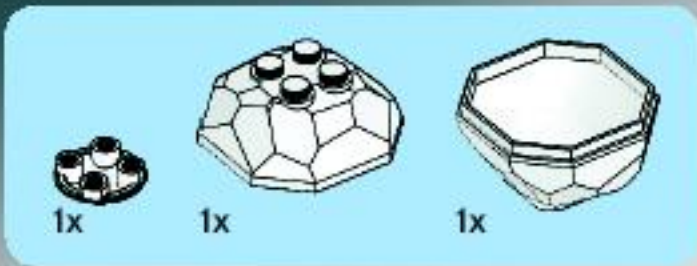

30

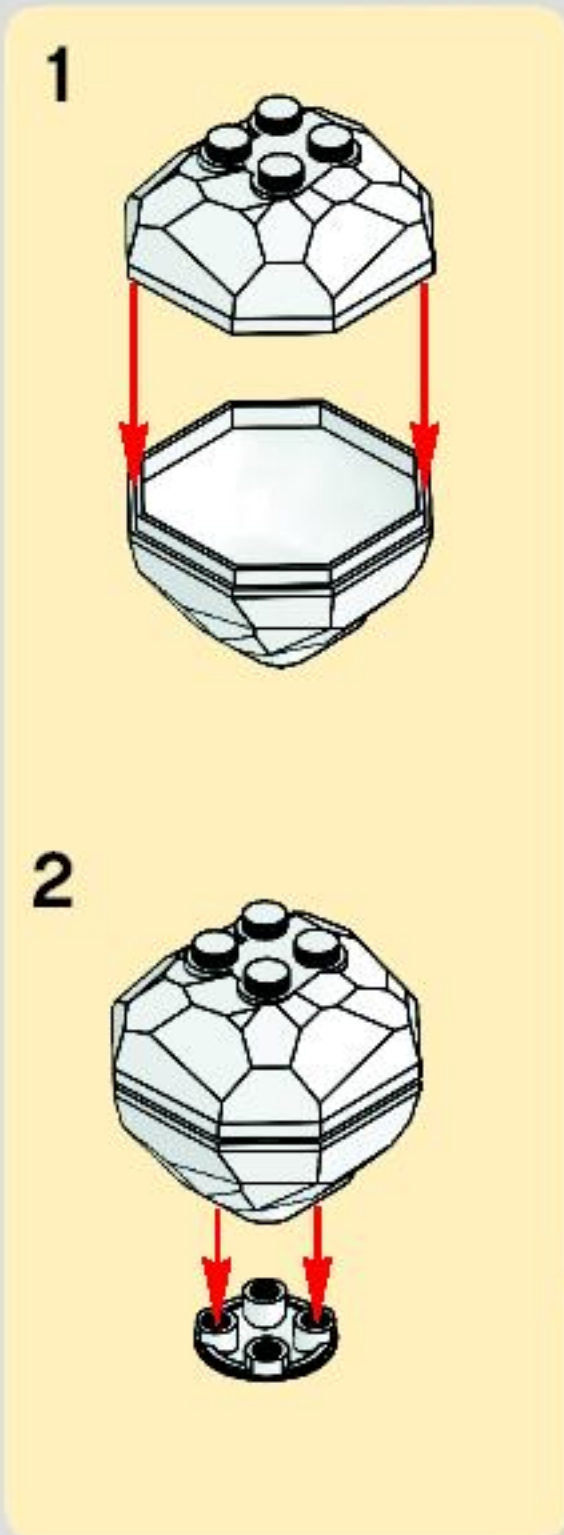



World Racers





LEGO 5

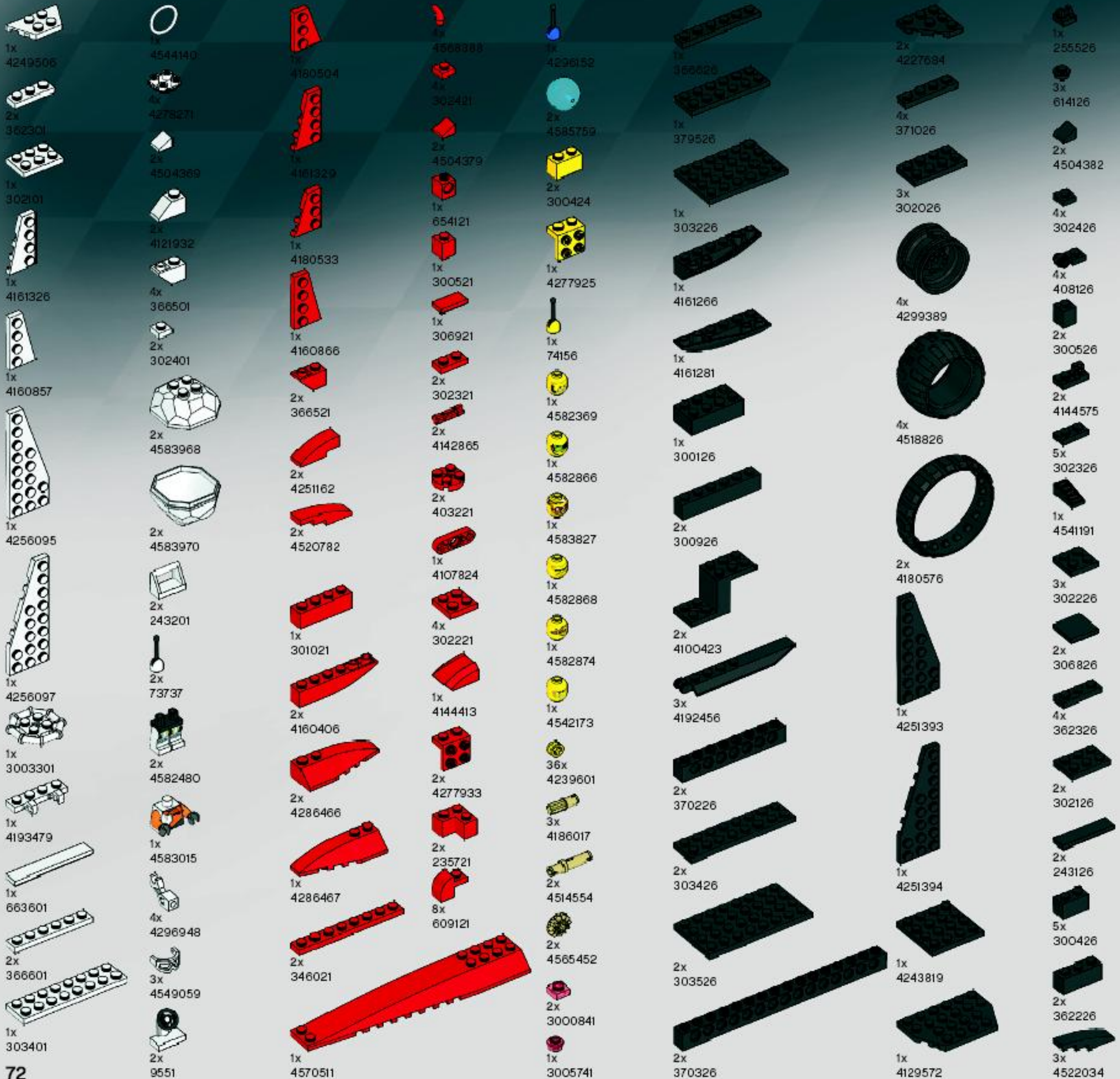



Customer Service

Kundenservice

Service Consommateurs

Servicio Al Consumidor

www.lego.com/service or dial



: 00800 5346 5555

: 1-800-422-5346



World Racers



race 6

FREE! GRATIS! GRATUIT!



club
MAGAZINE™

www.LEGOclub.com



00800 5346 5555*

1-866-534-6258 • 1-877-518-5346
US & Canada only Canada seulement



VISIT THE WORLD'S
BIGGEST LEGO® SHOP!

www.LEGOshop.com

* Free phone. Mobile charges may apply. * Numéro sans frais. Des frais peuvent s'appliquer avec les téléphones cellulaires. * Geldfrei. Kosten für Anrufe aus Mobilfunknetzen können anfallen. * Gratis telefonnummer y van vaste lijn. * Det er ett gratis nummer, uti du ringer fra fasttelefon. * Det är gratis, uti du ringer från en fast telefon.



World Racers



8896



8897



8898



8899



8863



8864