



TECHNIC

8045



1

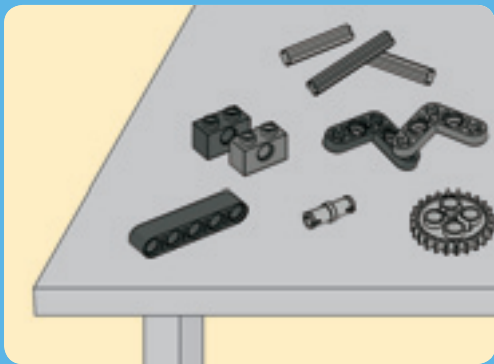

2

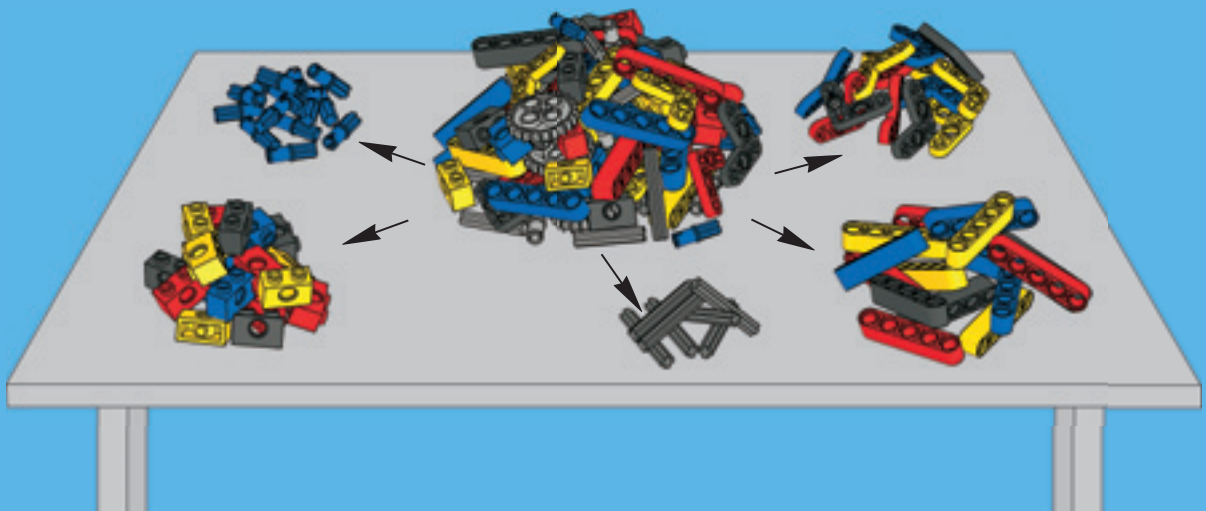

2

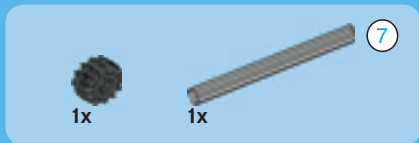

1

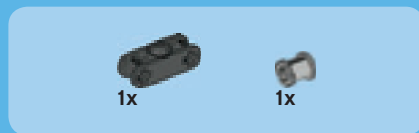
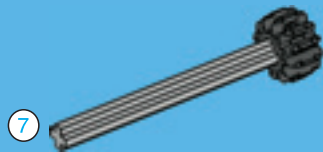

2

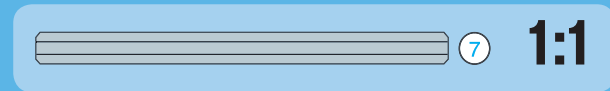
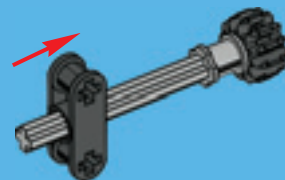

3



3

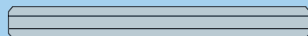
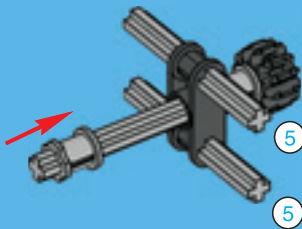

5

1:1

4



4

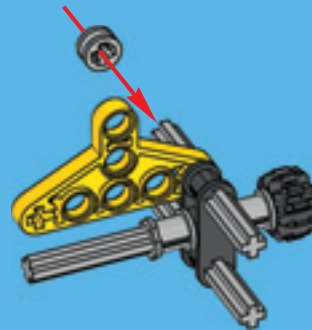



1x



1x



1x

5

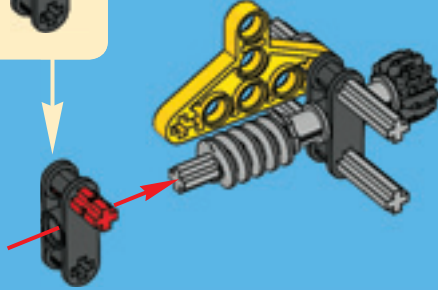

5

1x

6

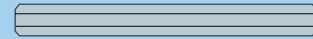
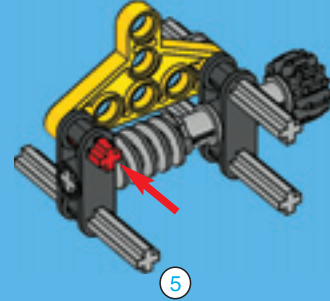

5

1:1

5



7

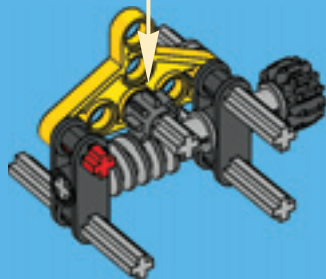

1:1

6

1x

1x

8

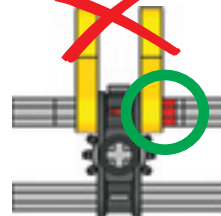
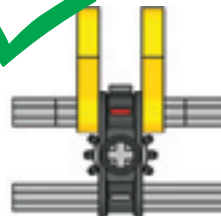
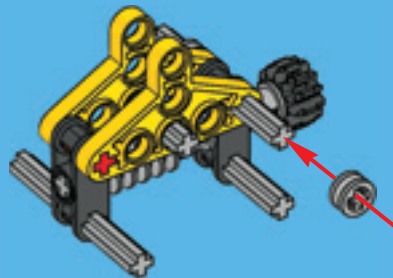



9

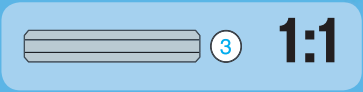
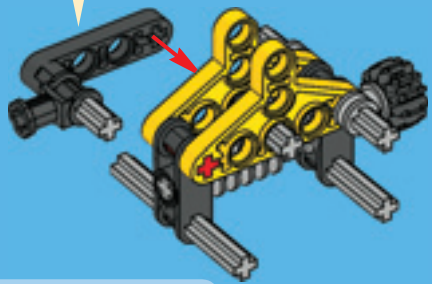
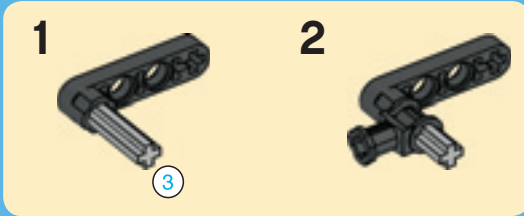

10

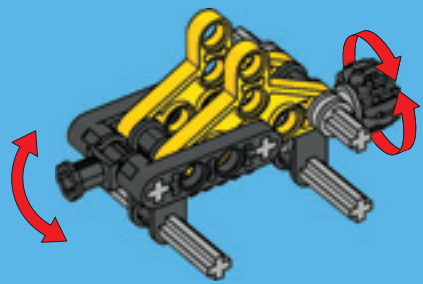

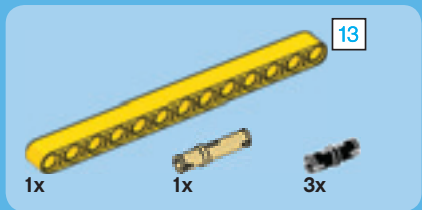

1

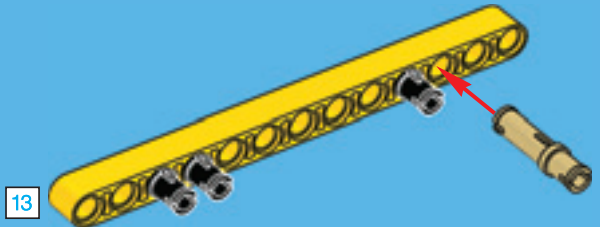

2

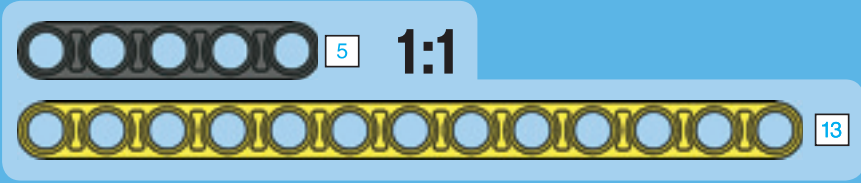
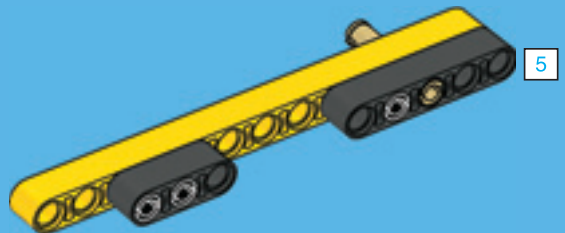

8



2x

3

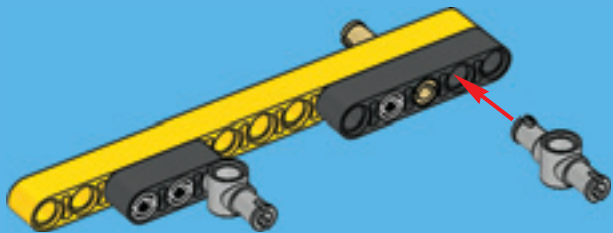

11

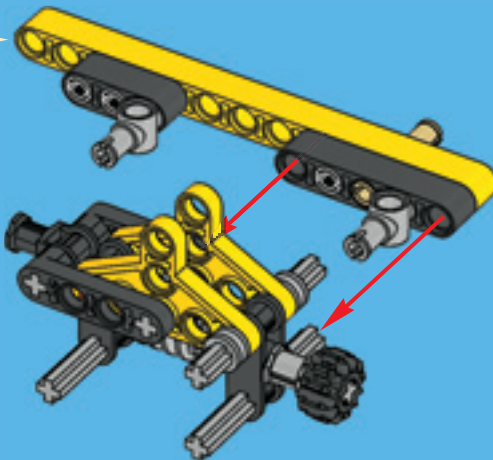



12

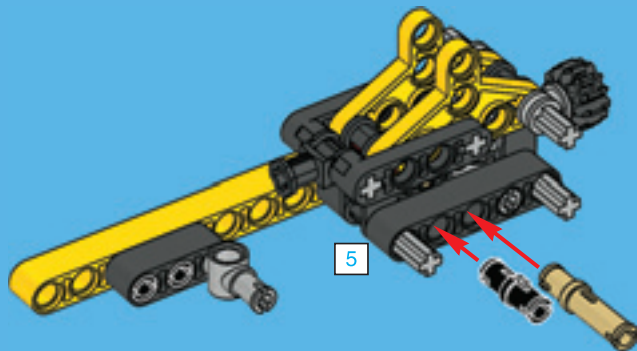

10



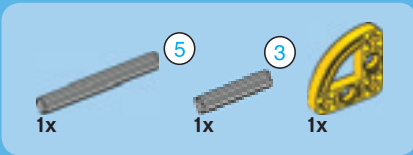

1

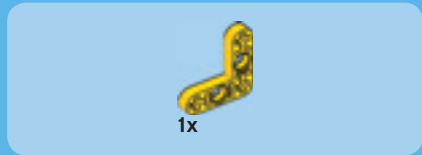
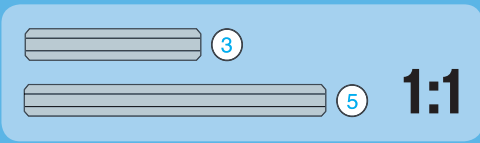
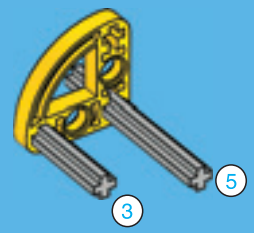

2

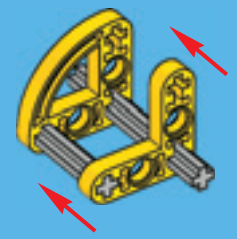



3



12



4

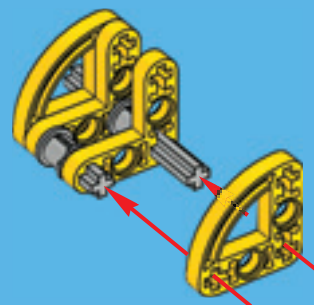



2x

5

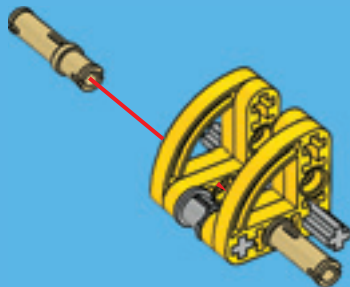

2x



2x

6

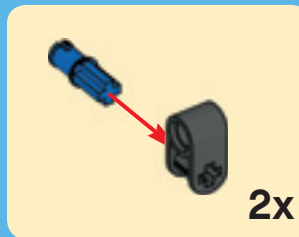

13

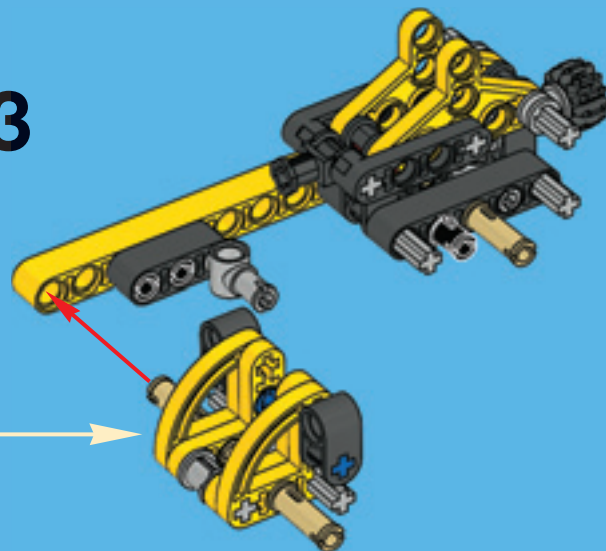

14

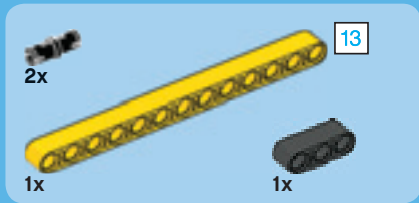

14

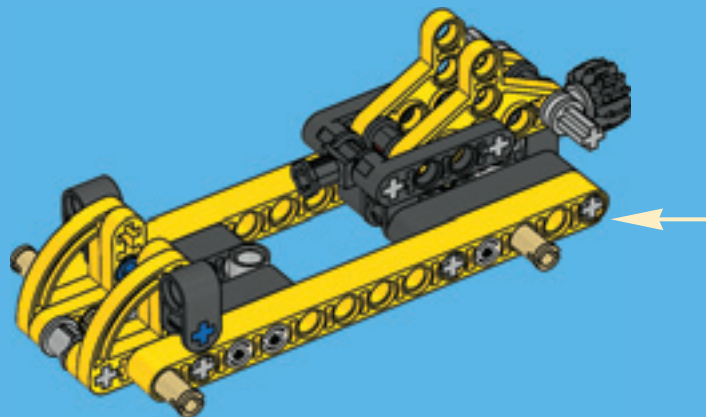
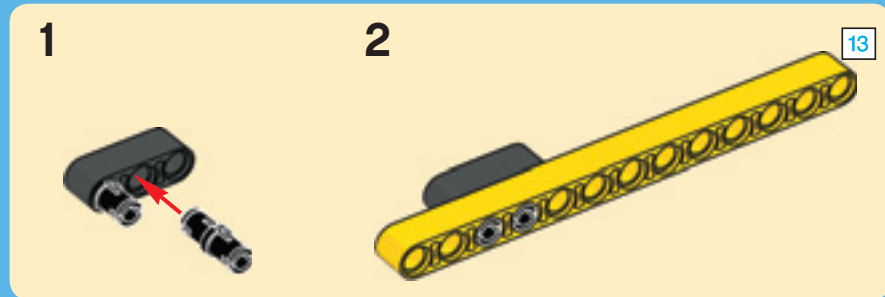

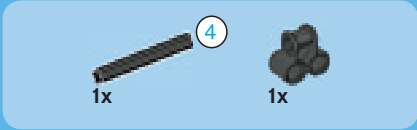

1

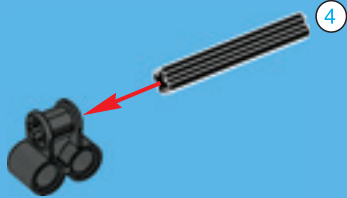

16

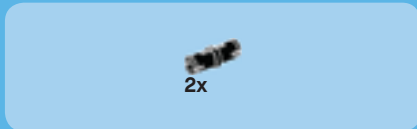

2

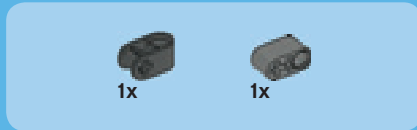

3

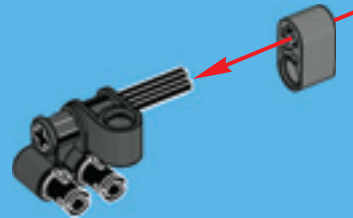



4

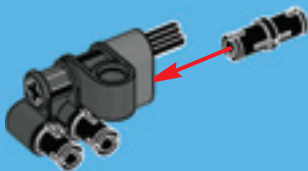

5

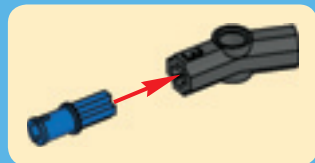



6

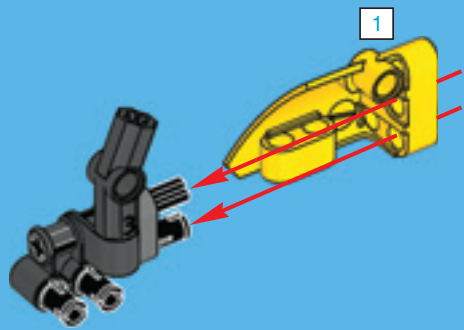

15

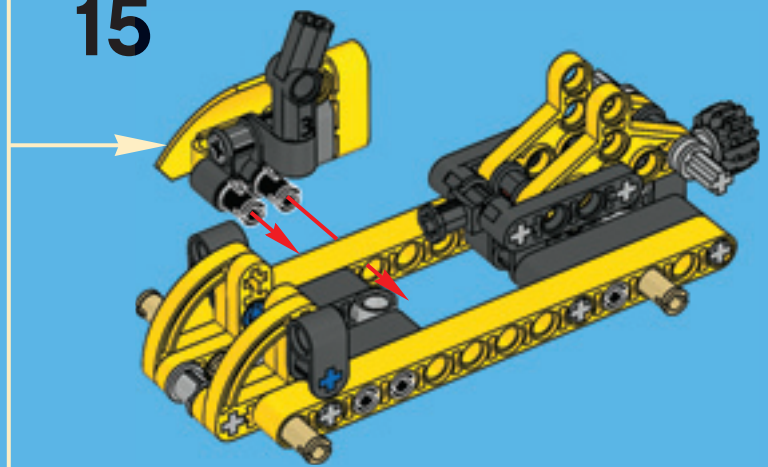

18



2x



2x

16

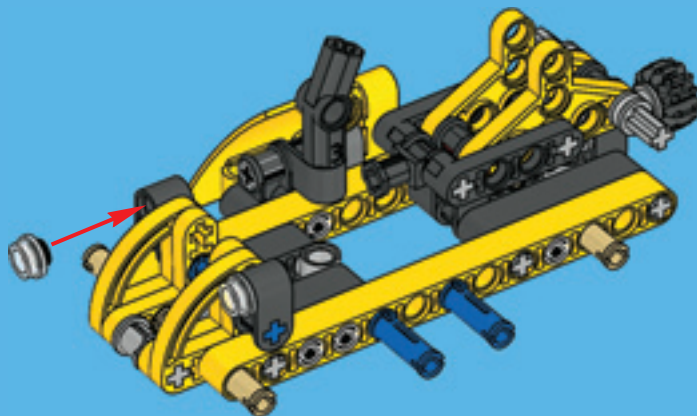

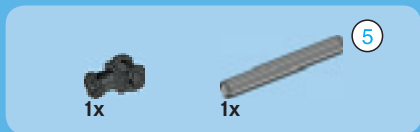

1

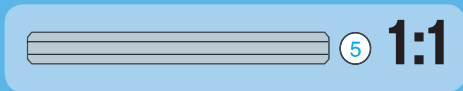
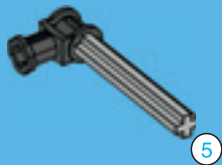

20



2

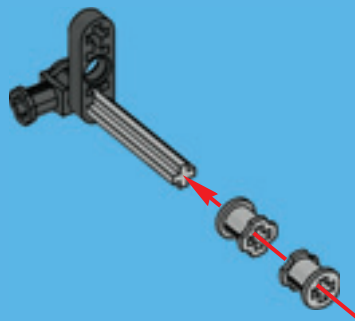

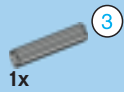

3

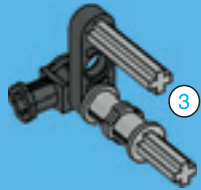

1:1



4

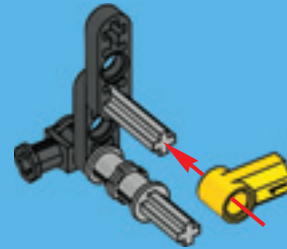



2x

5

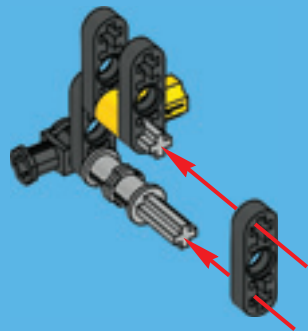

22



1x

6



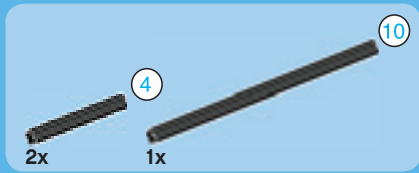

7

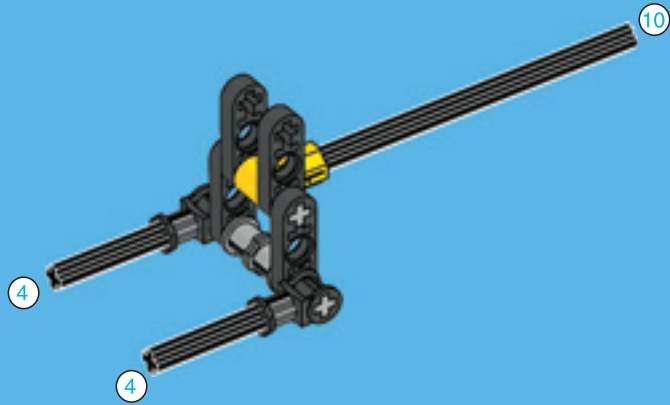

17

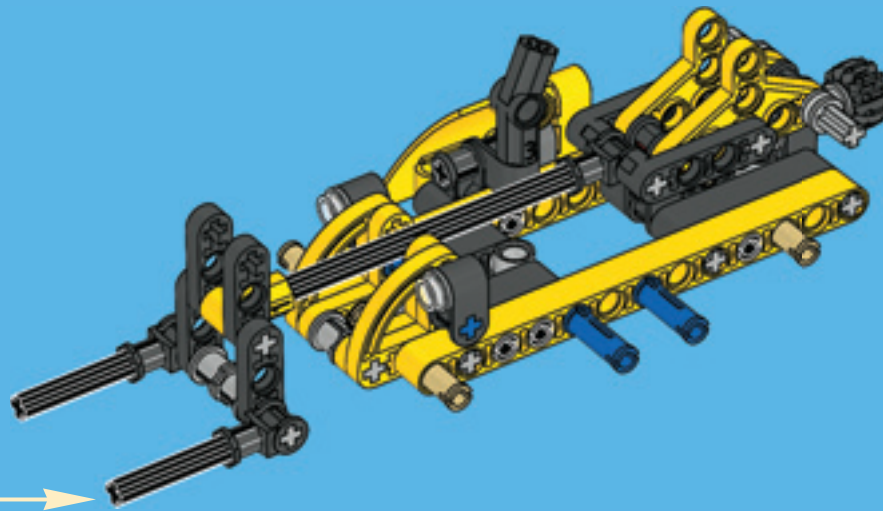

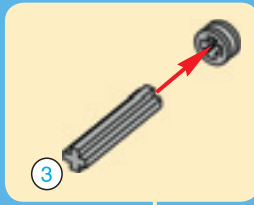
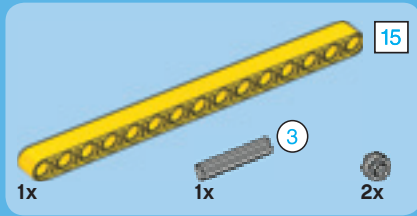

18

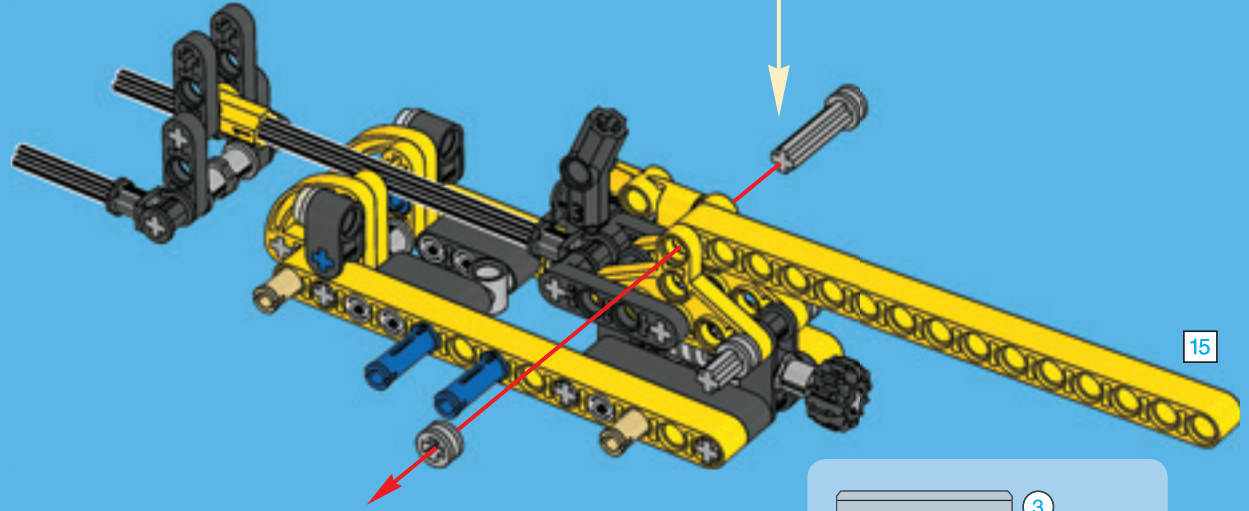

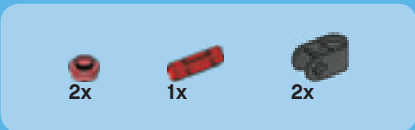

19

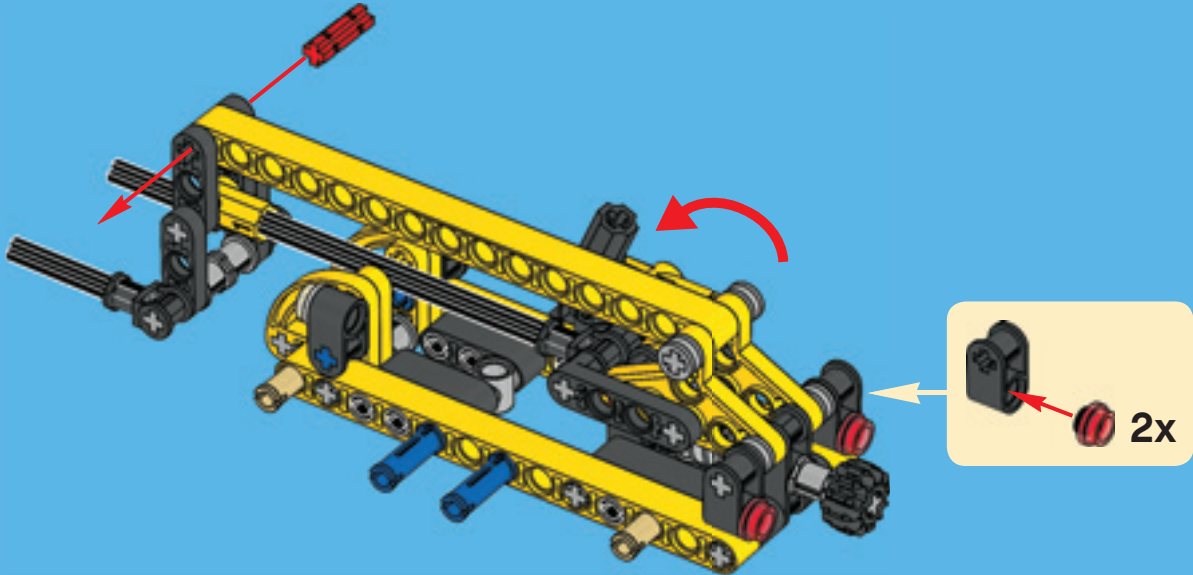



1

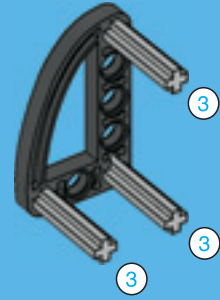

2

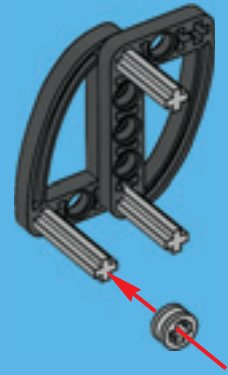



1x



2x

3

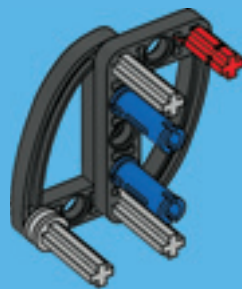

28



2x

4

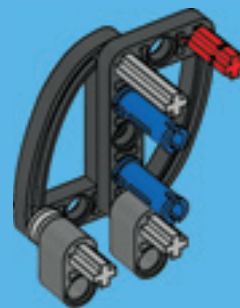



1x



1x

5

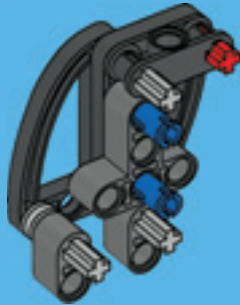

1x



1x

6

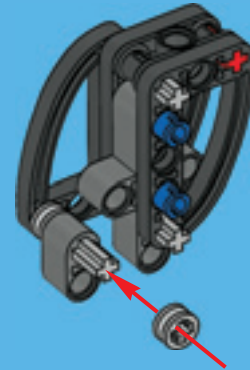



7

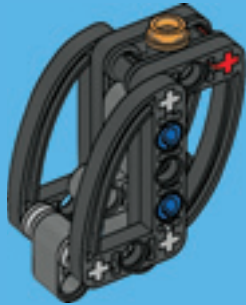

30

20

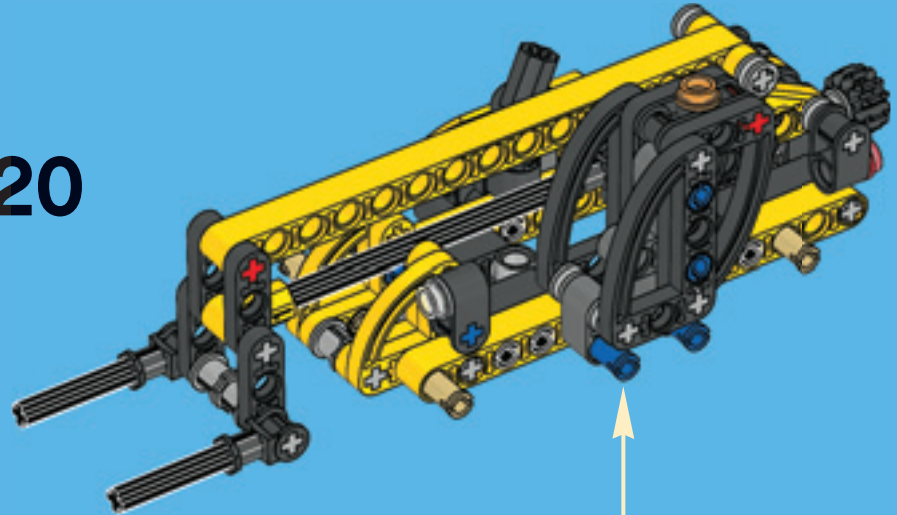



21

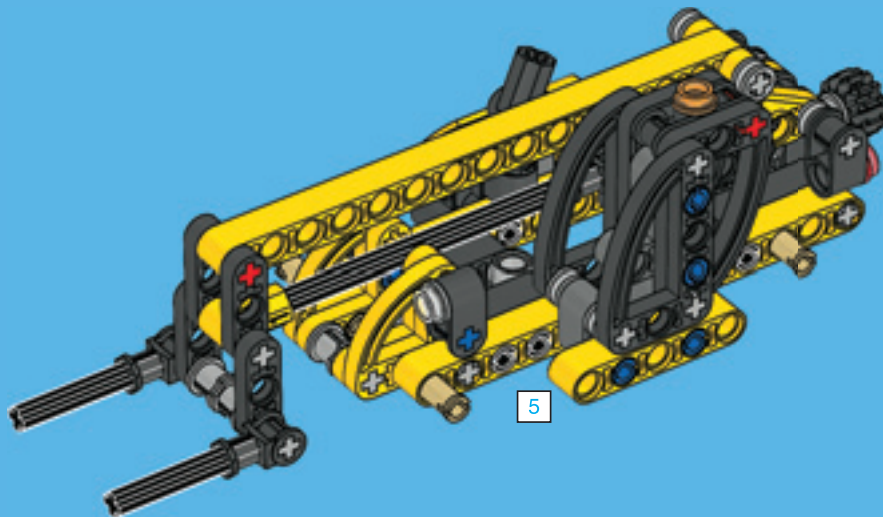



4x



4x

22

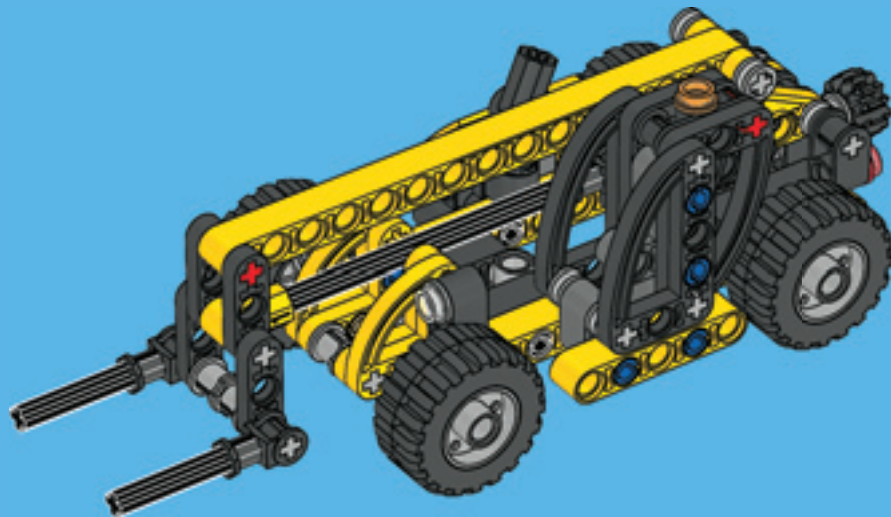

32



23

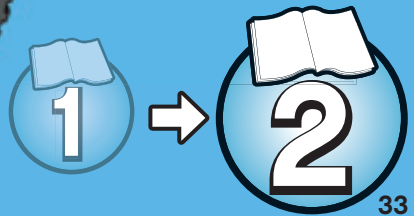
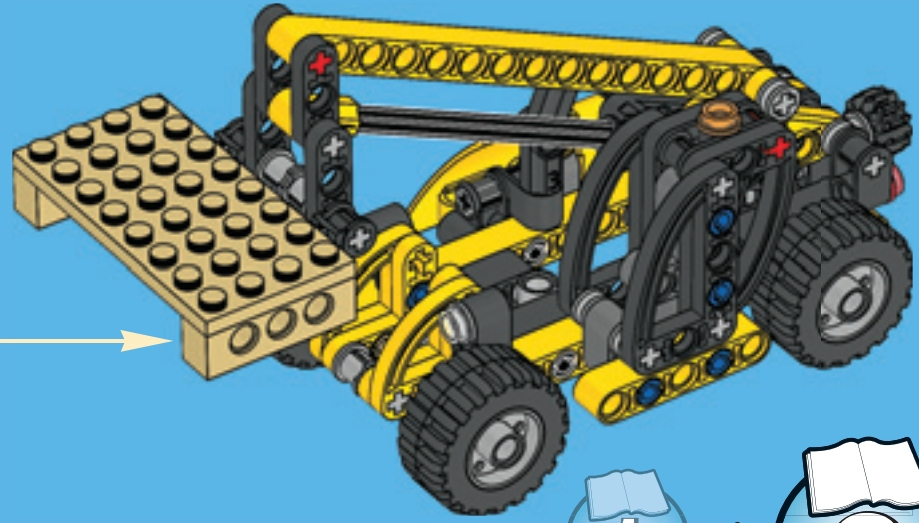
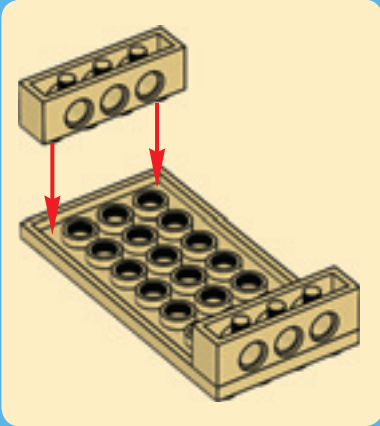

3x
4142865

2x
3005741



1x
4509897



2x
4234365



4x
4514554

3x
4107081

5x
4173668

1x
4177431

3x
4121667

4x
4107828

2x
4142822

2x
4142135

5

4x
4128557

1x
4107082

2x
4107136

4x
4140670

1x
4140430

9x
4121715

3x
370526

4

1x
373726

10

1x
4107066

2x
4522935

1x
4542579

1x
4142133

2x
4500483

2x
4112289

2x
4296140

1x
4558879

13

15

1x
4211805

5x
4211639

8x
4211815

2x
4560175

4x
4299119

1x
4211510

3x
4206482

4x
4514553

7

5

3

6x
4211573

6x
4211622

2x
3005740

1x
4222960

3x
4515183

1x
4514559

1x
4552349

Customer Service
Kundenservice
Service Consommateurs
Servicio Al Consumidor
www.lego.com/service or dial



00800 5346 5555 :

1-800-422-5346 :

FREE! GRATIS! GRATUIT!



club
MAGAZINE™

www.LEGOclub.com



00800 5346 5555*

1-866-534-6258 • 1-877-518-5346

US & Canada only

Canada seulement

* Freephone. Mobile charges may apply. * Numéro sans Frais. Des Frais peuvent s'appliquer avec les téléphones cellulaires. * Gebührenfrei, Kosten Für Anrufe aus Mobilfunknetzen können abweichen. * Gratis telefoonnummer vanaf vaste lijn. * Dec er etc gratis nummer, når du ringer Fra Fasttelefon. * Dec är gratis, när du ringer Från en Fast telefon.



VISIT THE WORLD'S
BIGGEST LEGO® SHOP!

www.LEGOshop.com



WIN!

Go to www.nielsen.com/LEGO
to fill out a survey for a chance
to win a cool LEGO® Product.

No purchase necessary.

Open to all residents where not prohibited.

 www.LEGO.com

www.nielsen.com/LEGO

GEWINNE!

Nimm an der Umfrage auf
www.nielsen.com/
LEGO teil und hab die Chance ein cooles
LEGO® Produkt zu gewinnen!

Die Teilnahme am Gewinnspiel führt zu keinerlei
Kaufverpflichtungen. Teilnahme in allen nicht
ausgeschlossenen Ländern möglich.

WIN!

Ga naar www.nielsen.com/LEGO,
vul een enquêteformulier in en
maak kans op een
cool LEGO® product.

Geen aankoopverplichting.
Iedereen mag deelnemen, uitgezonderd
ingezetenden
van landen waar een enquêteverbod geldt.

GAGNE!

Visite www.nielsen.com/LEGO
pour répondre à un questionnaire
et avoir une chance de gagner
un produit LEGO® très cool !

Aucune obligation d'achat.
Ouvert à tous les résidents des pays
autorisés.

当てよう!

www.nielsen.com/LEGO
にアクセスして、
アンケートにご記入ください。
当選者にはレゴ製品を
差し上げます。

お買い上げの必要はありません。
禁止されていない限り、すべての皆様にご利用いただけます。

4582891

LEGO and the LEGO logo are trademarks of the LEGO Group. ©2010 The LEGO Group. ©2010 LucasFilm Ltd. & TM. All rights reserved. Used under authorization.



TECHNIC

8045



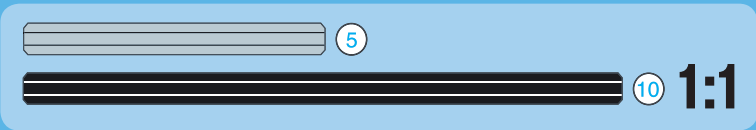
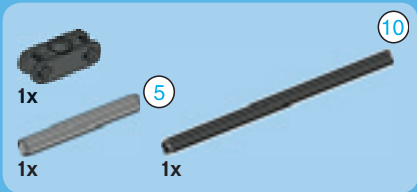
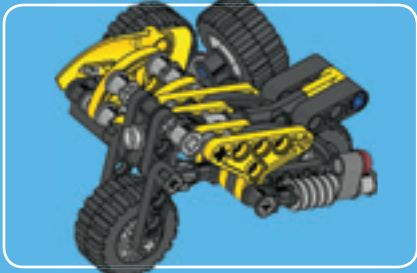

1

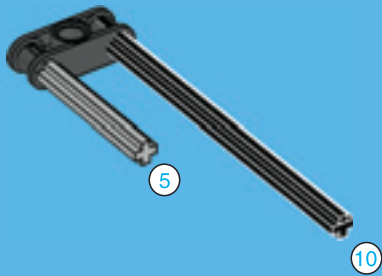

2



2x

2

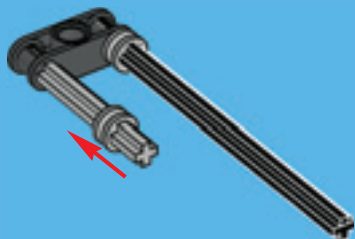

1x



1x

3

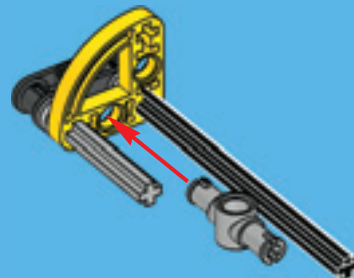

3



4

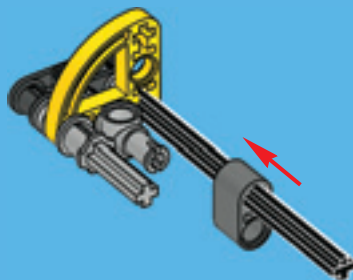

4

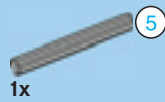

5

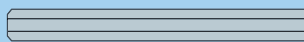
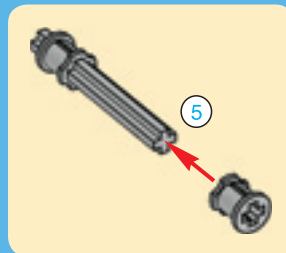

5

1:1



1x



1x

5

6

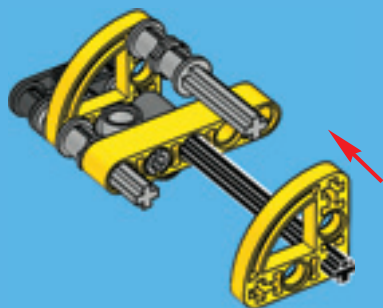

5

1:1



2x

7

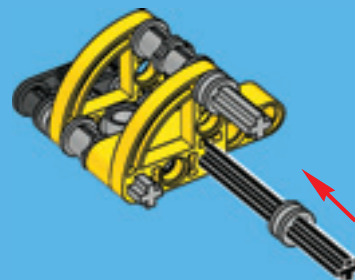

5

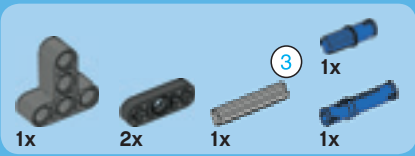

8

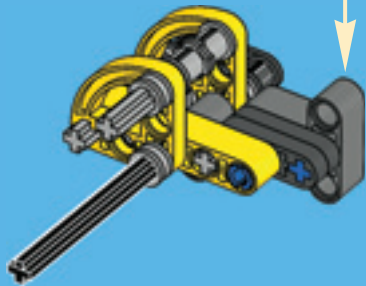

6



2x

9

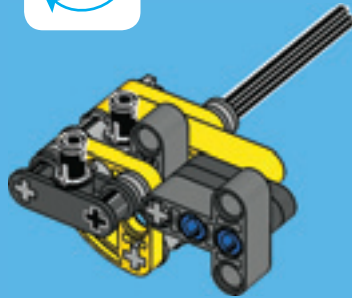

1x

10

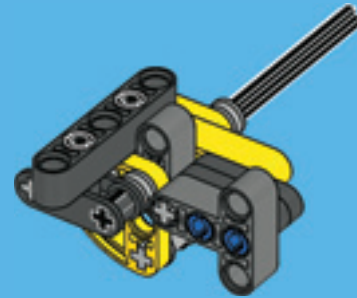

5

1:1

7



1x

11

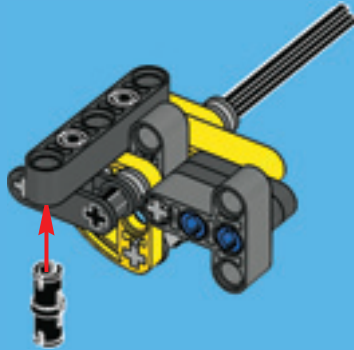

8



1x

12

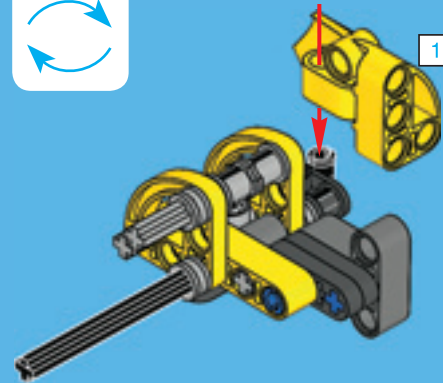

13

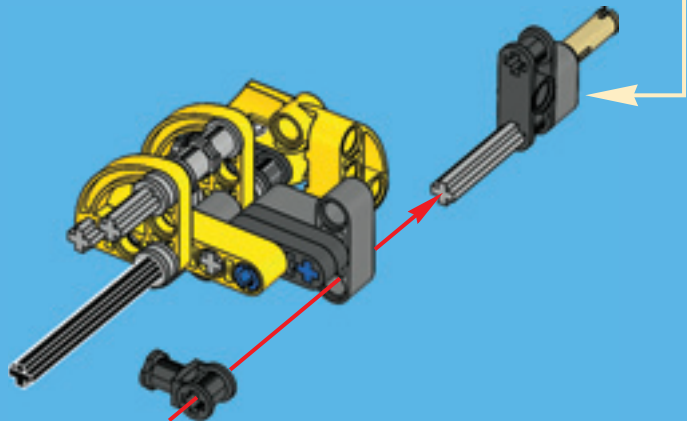
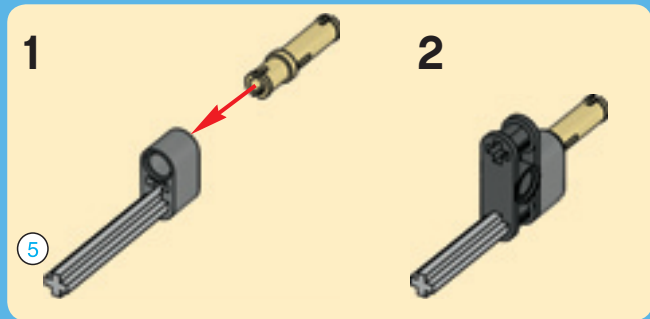
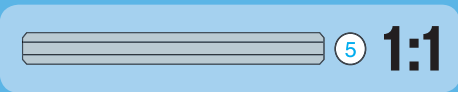
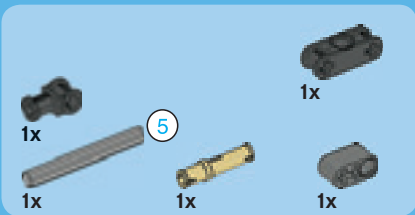



14

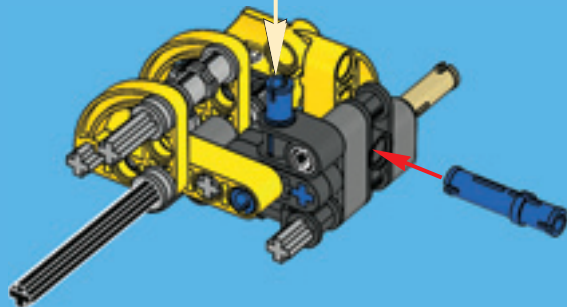
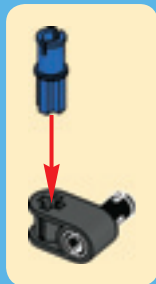

10



15

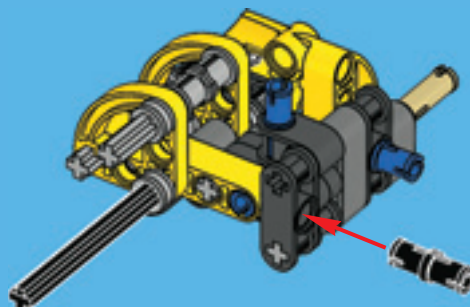

1x

1x

16

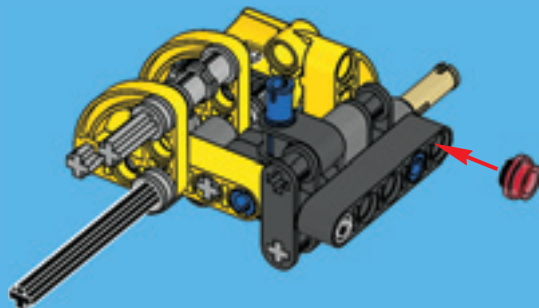

1x



1x

17

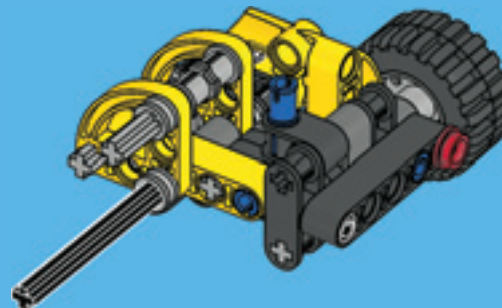



1x

18

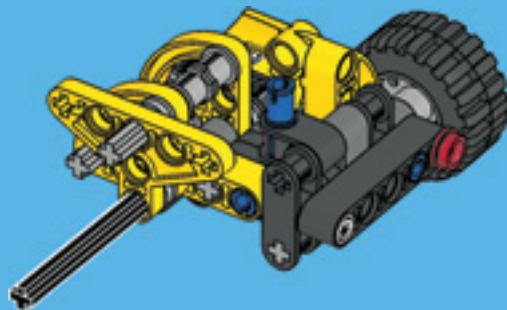

12



1x



1x

19

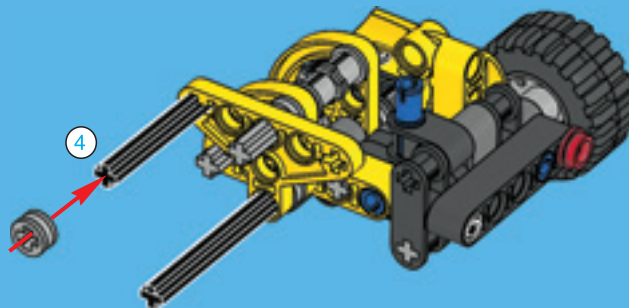

4

1:1



20

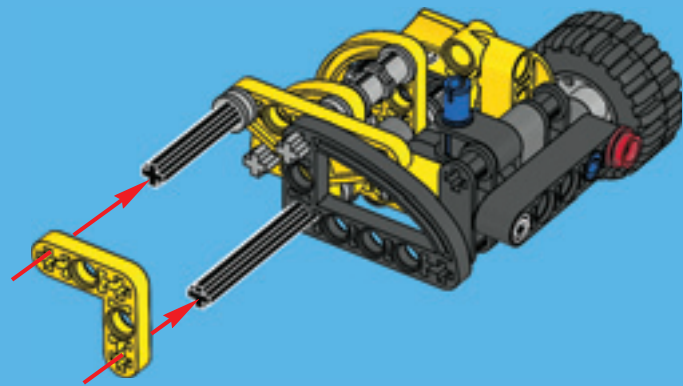



1x



1x



1x

21

1



2

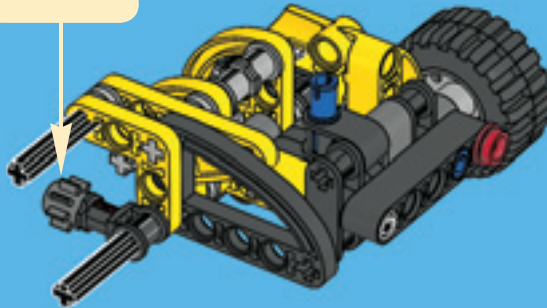



2x



1x

22

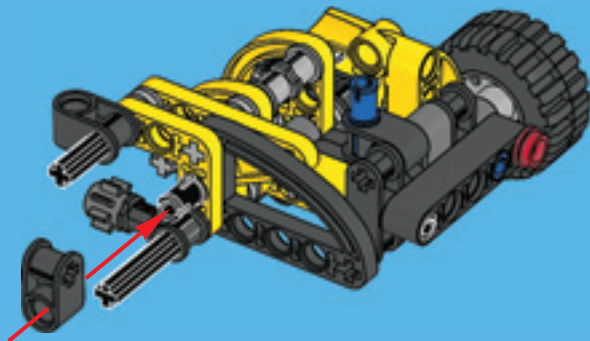

1x



1x

23

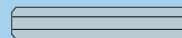
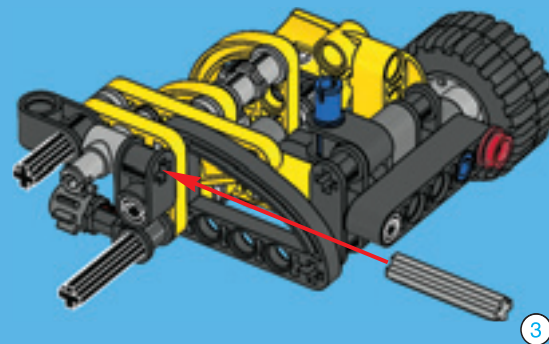

3

1:1

15

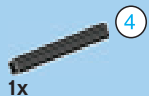

24

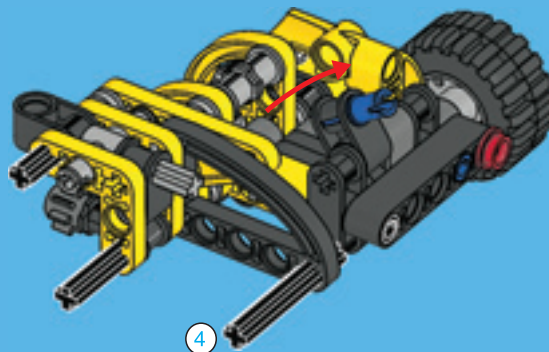

4

1:1

16



2x



2x

25

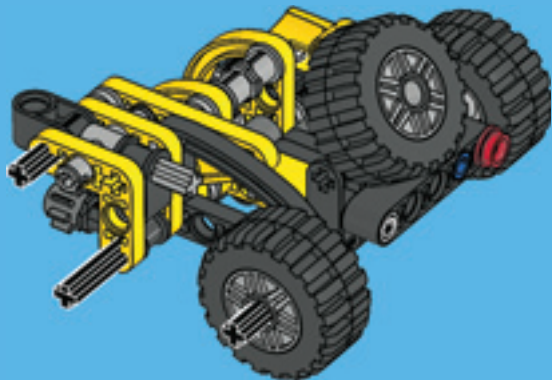

1x



1x

26

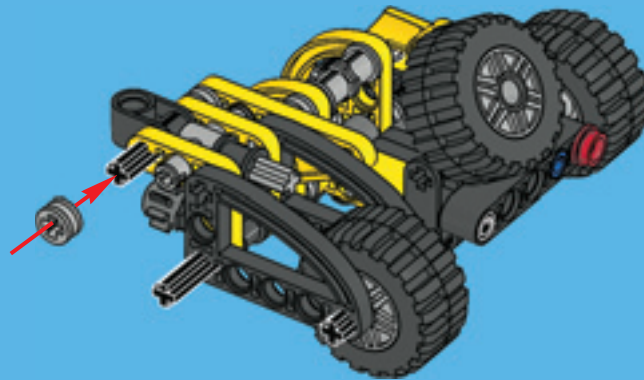



1x

27

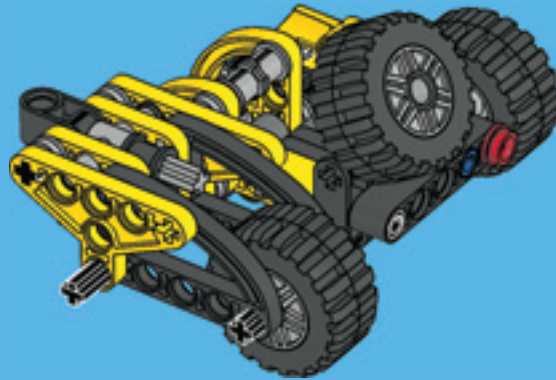

18

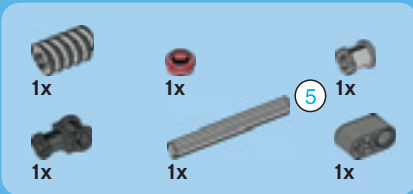

28

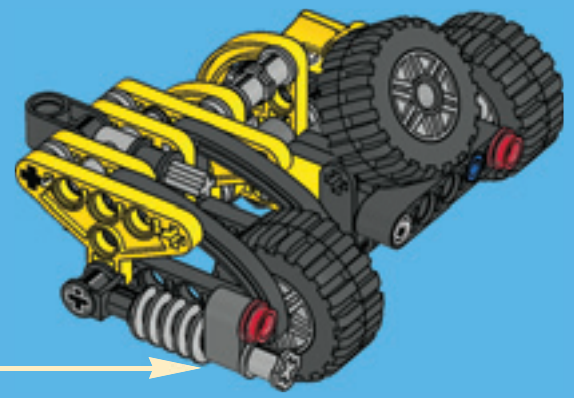
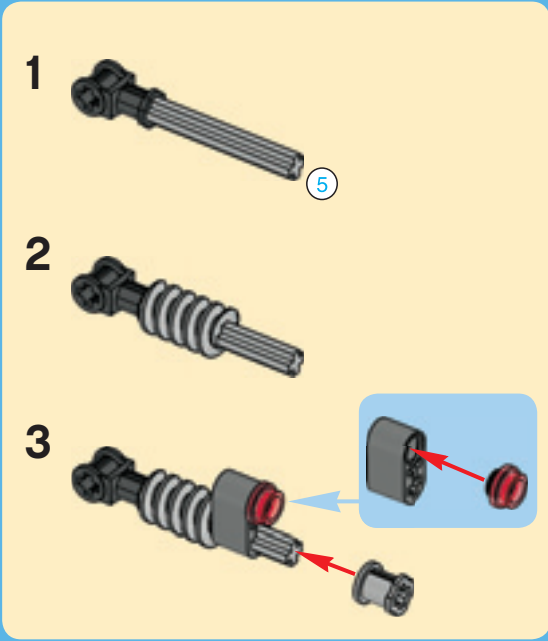



29

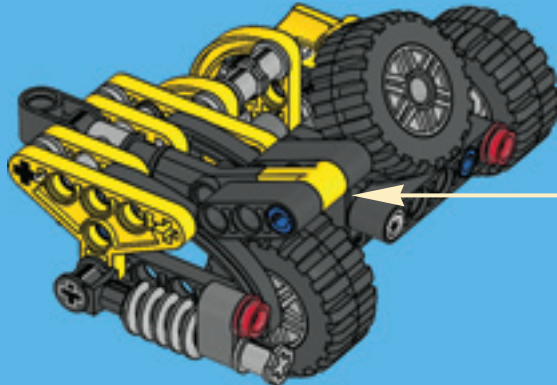



1





1x



1x

2



22



5

1x

3



5

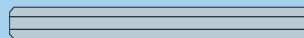

5

1:1



1x



1x

4

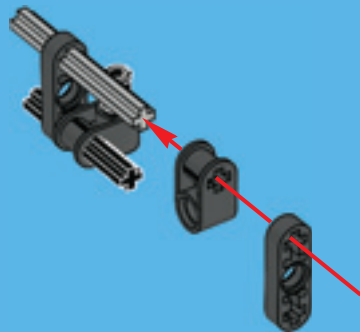

1x



2x

5

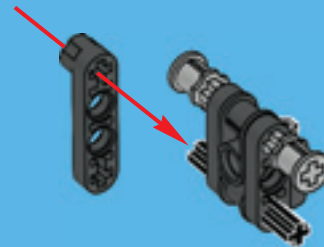

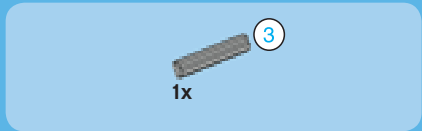

6

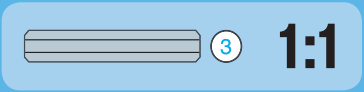
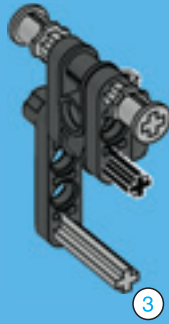

24



7

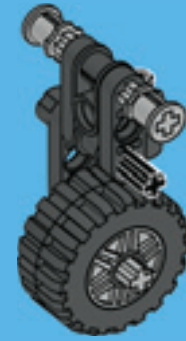

1x

1x

8

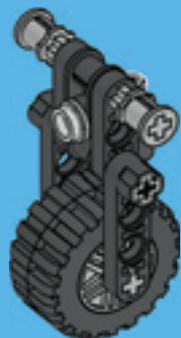

30

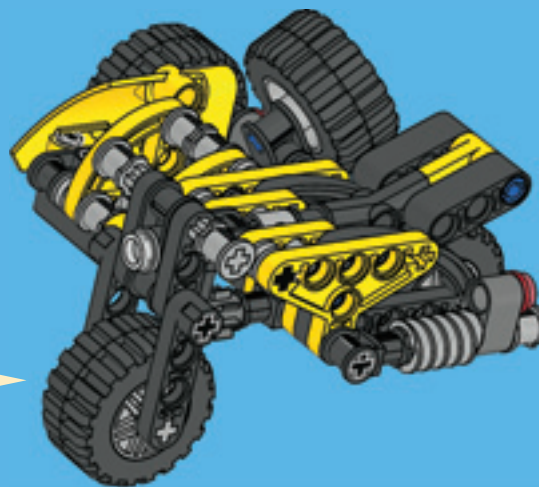

25



TECHNIC

8048





TECHNIC



8256



8261



8262

Technic.LEGO.com



 www.LEGO.com

©2010 The LEGO Group. 4582892