



Disney · PIXAR  
**TOY**  
STORY



7593



1

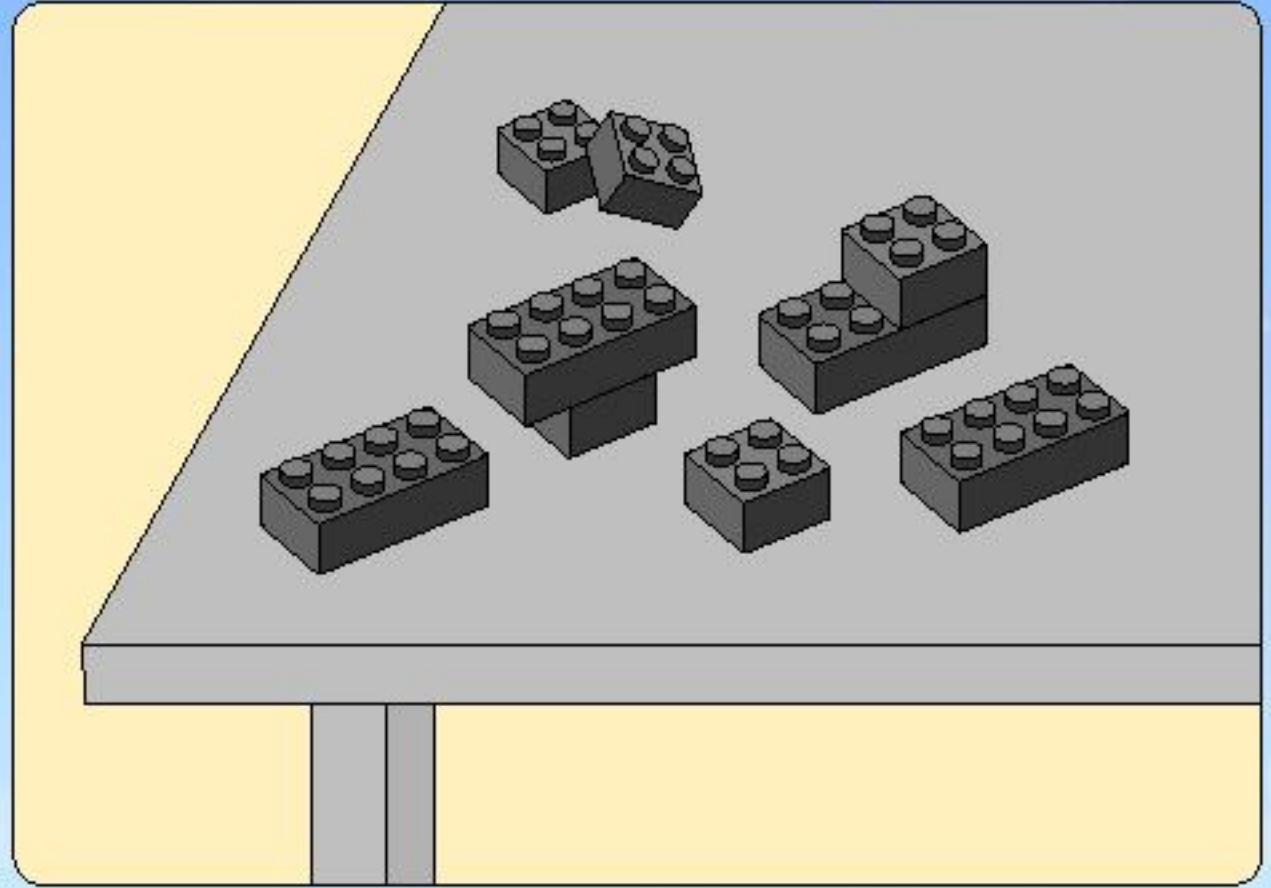
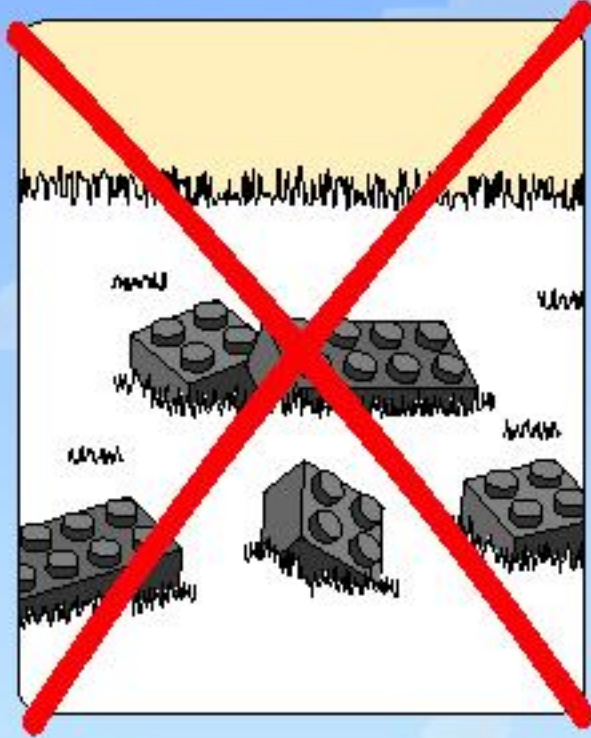

2

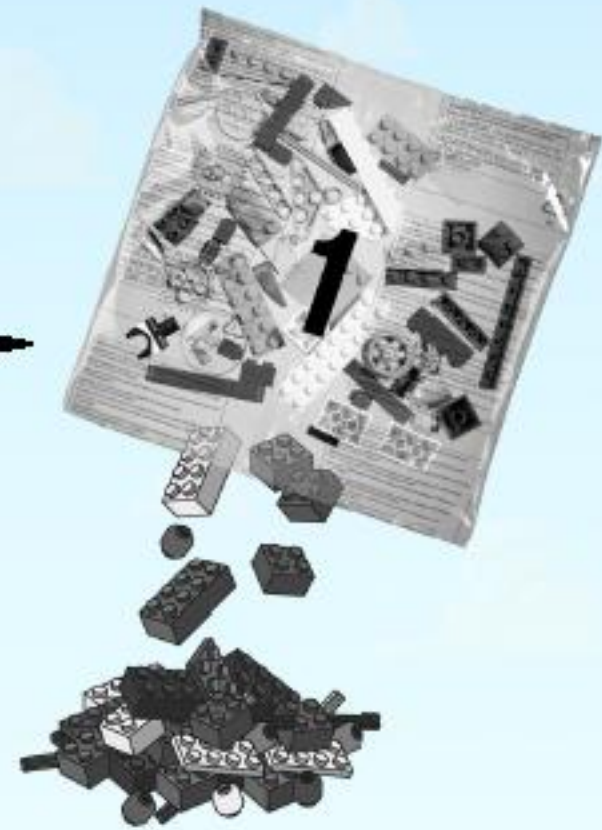

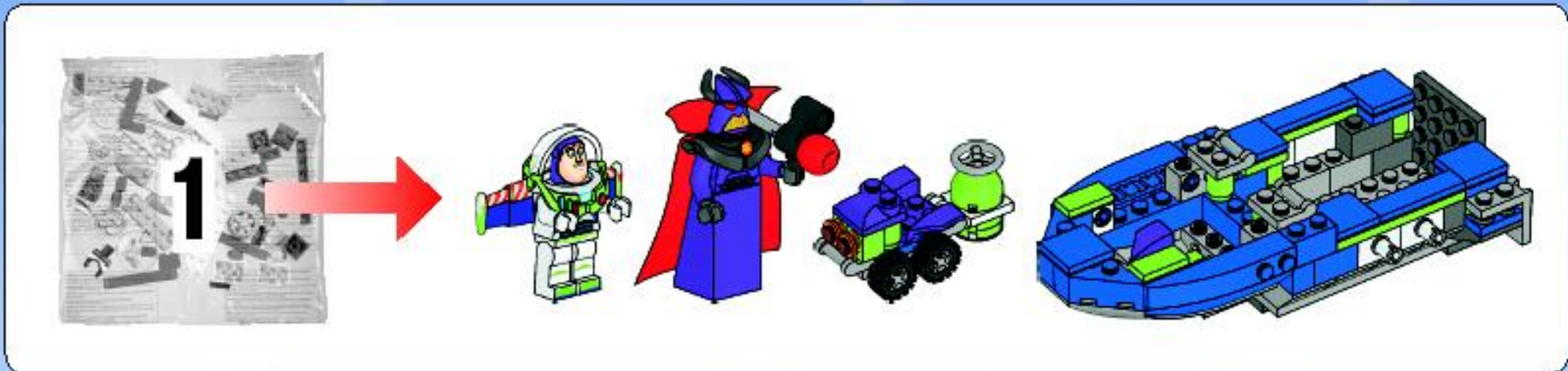

1



3



2



4

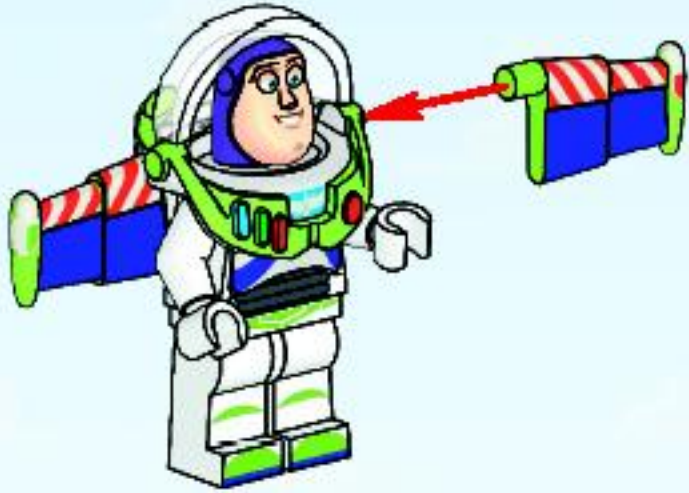

1

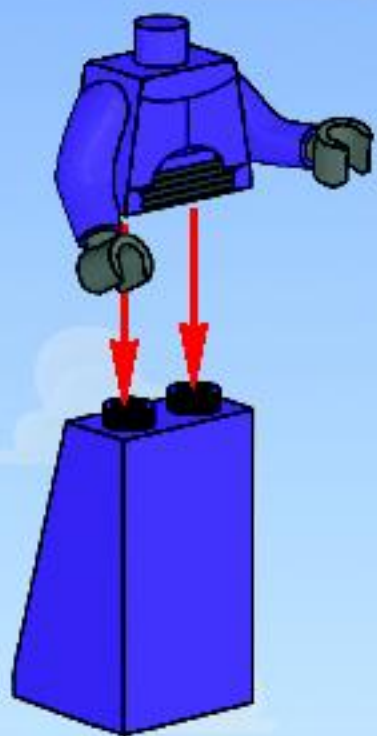

3



2

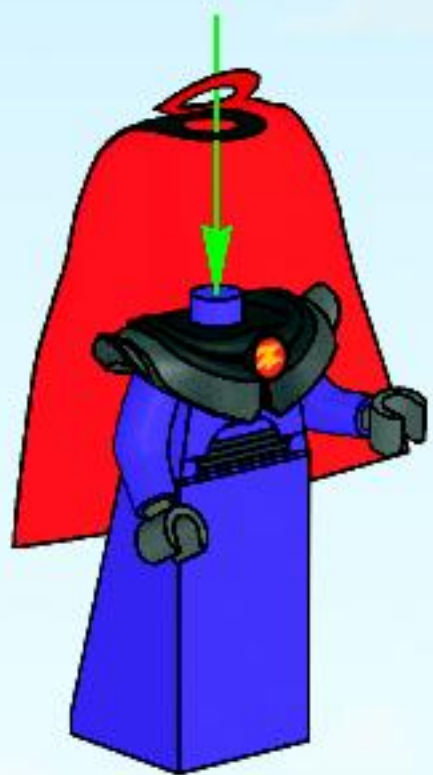

4



5

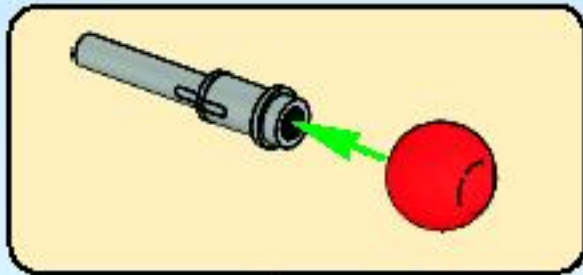

6

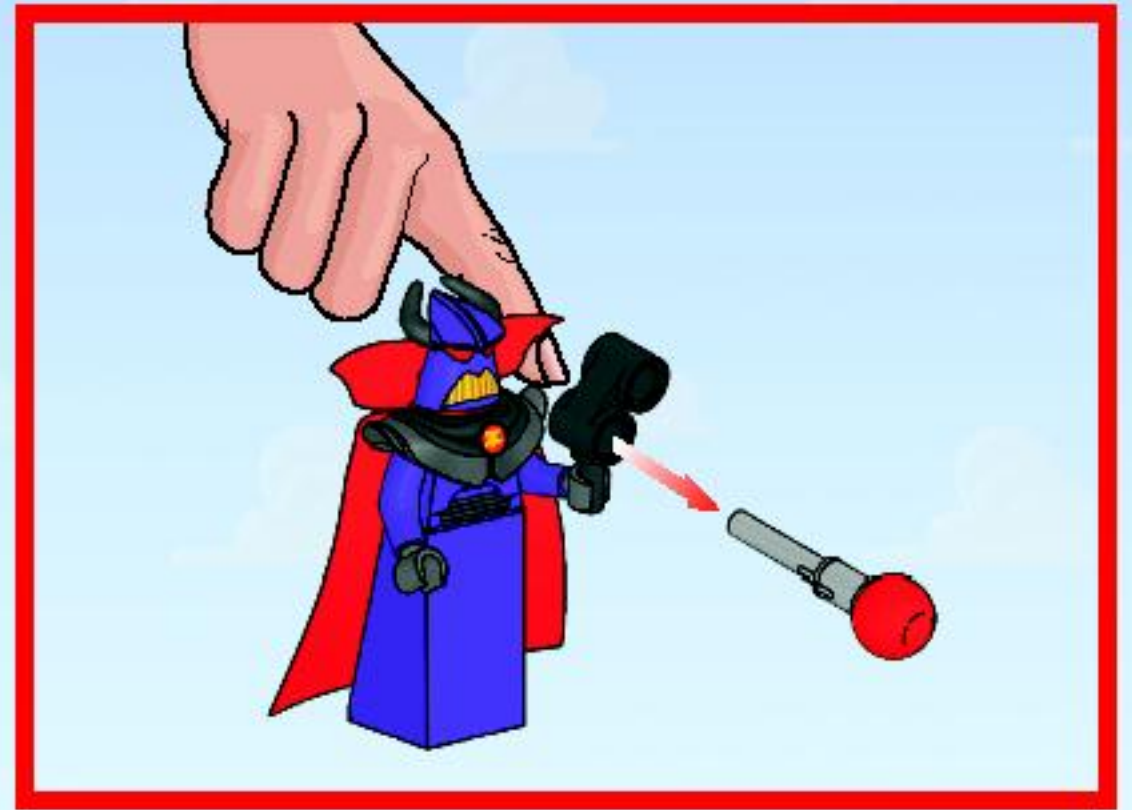



1

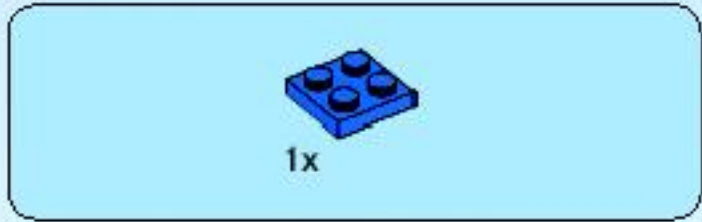
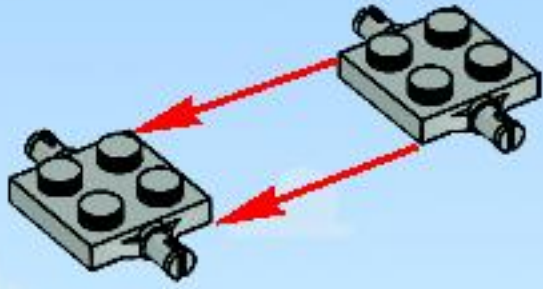

2

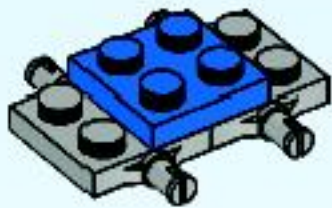

3

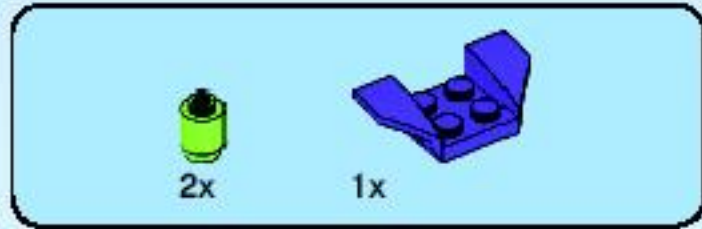
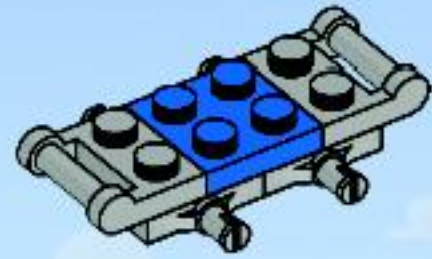

4

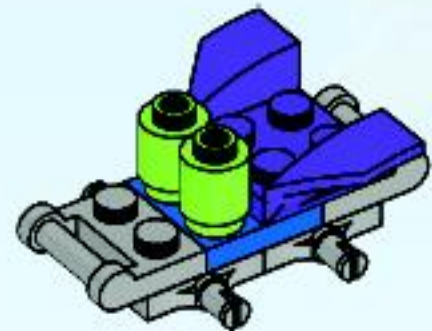



2x

5

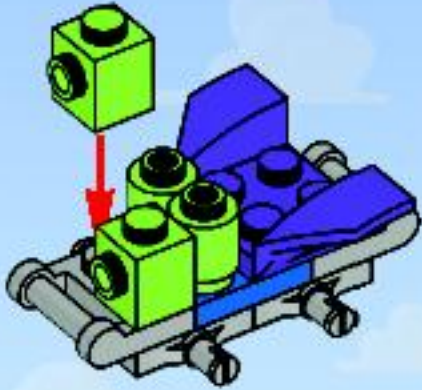

1x

6

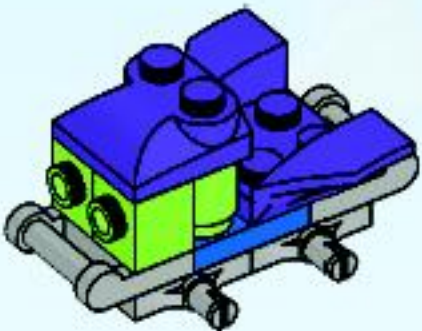

2x

7

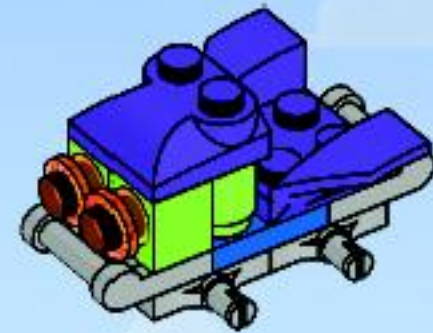

4x



4x

8





9

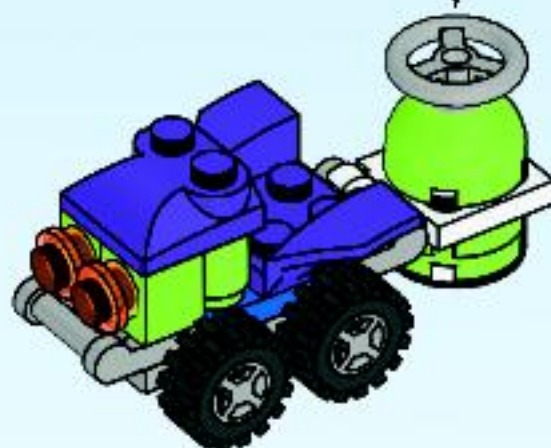
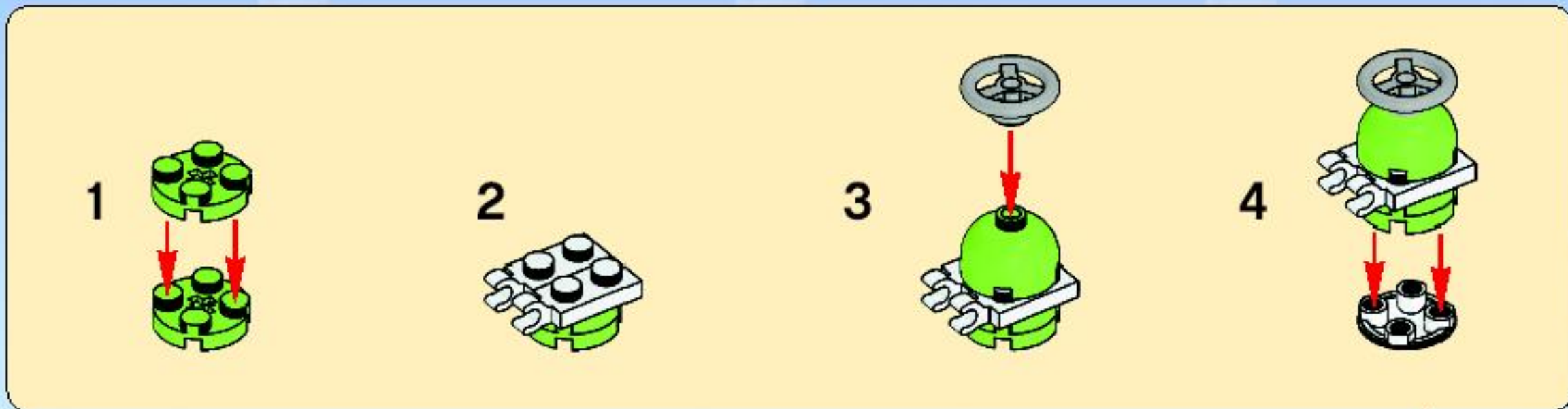



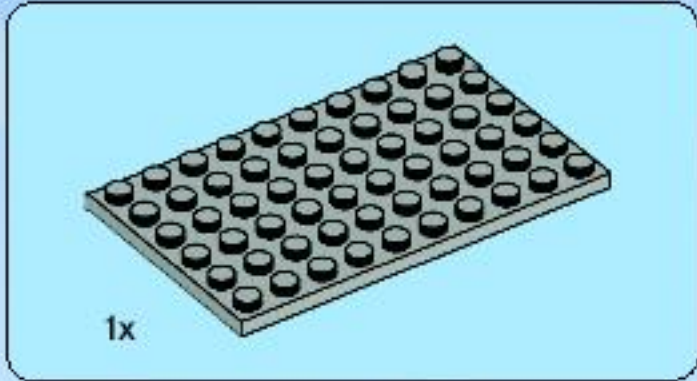
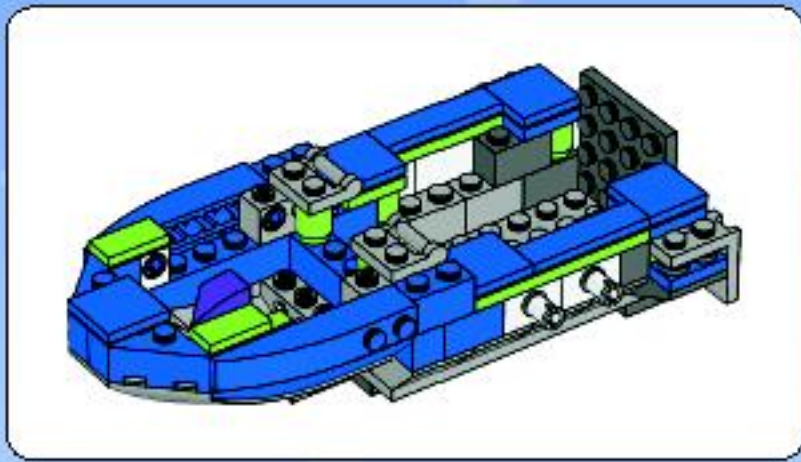

1x

**1**

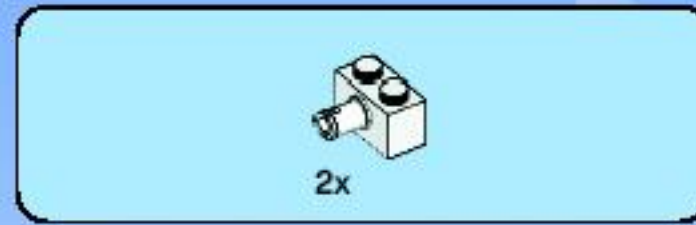
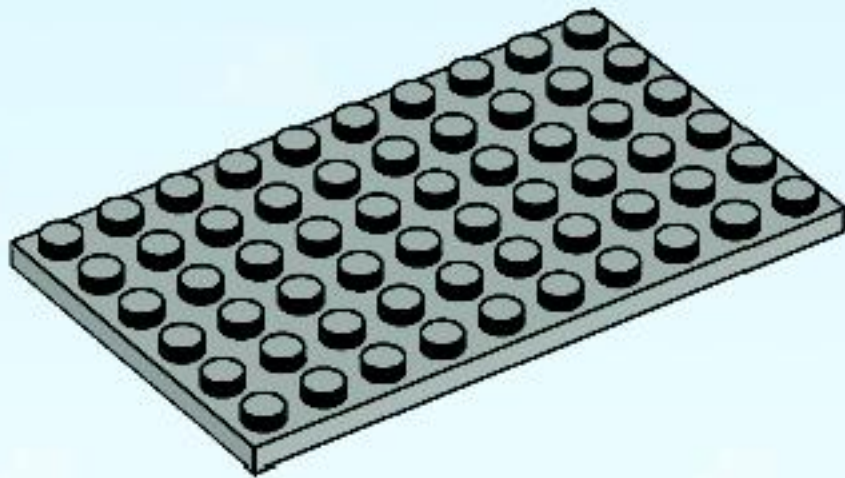

2x

**2**

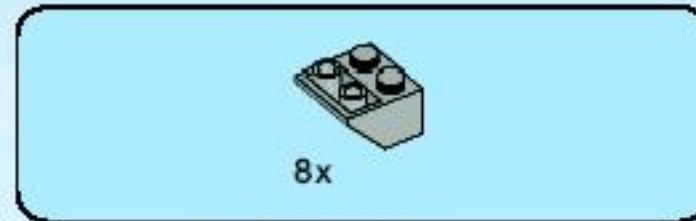

8x

**3**

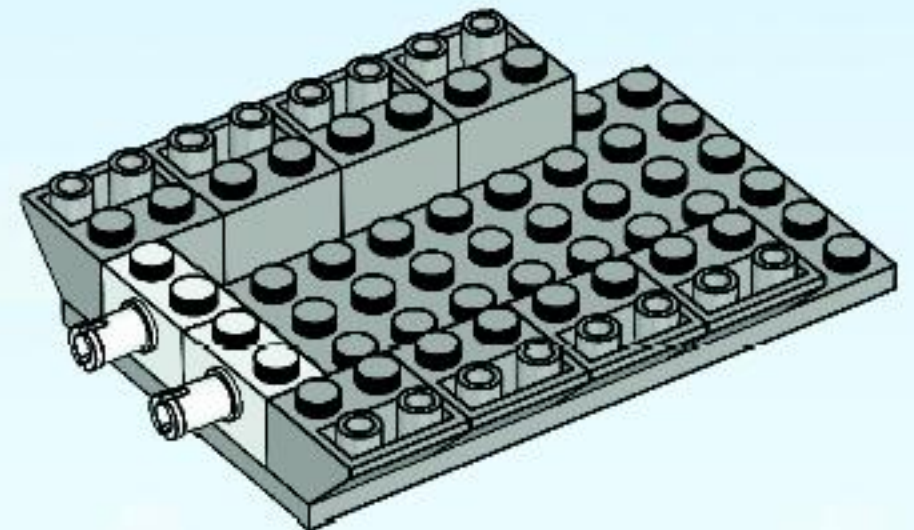

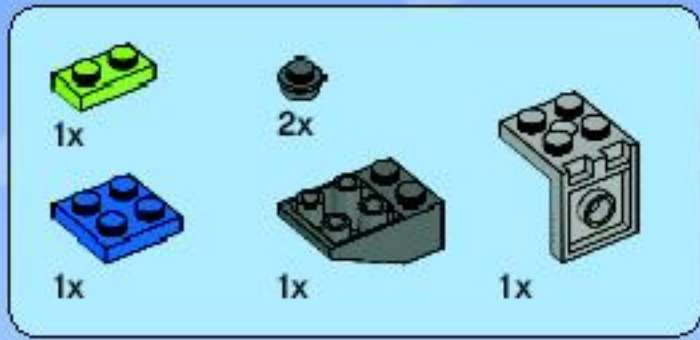

4

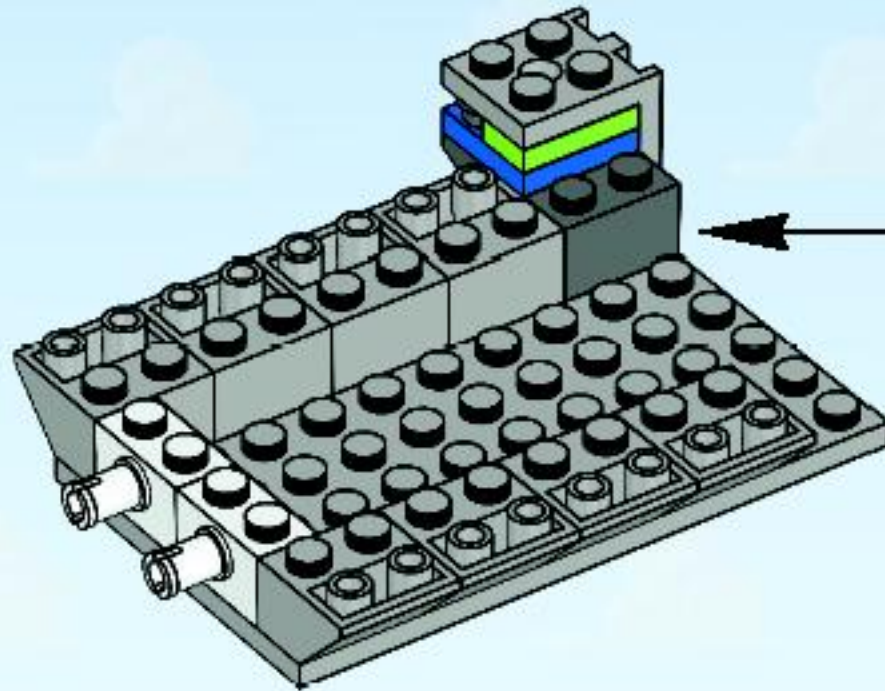
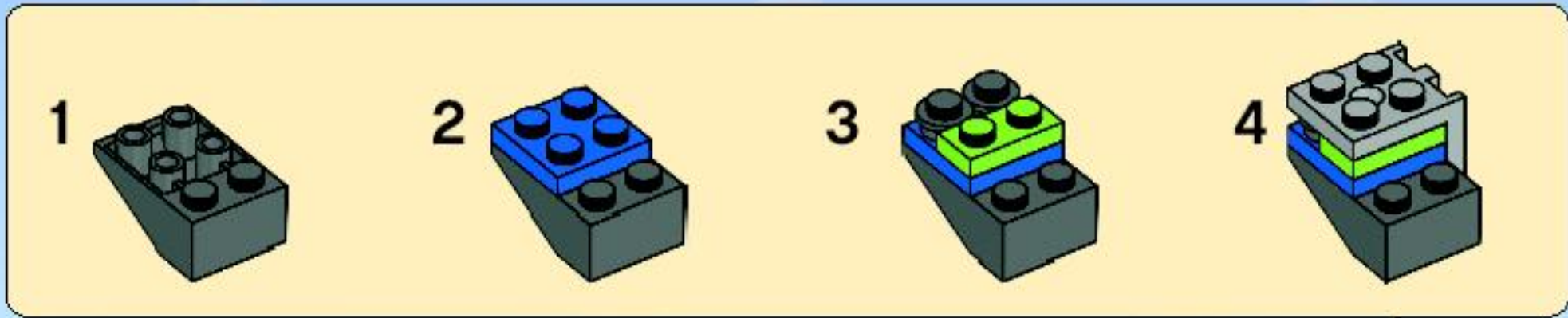

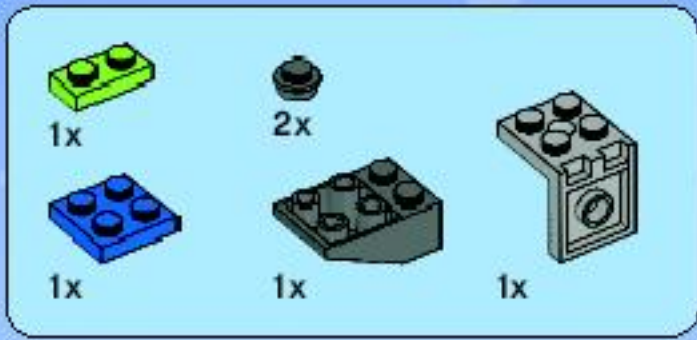

5

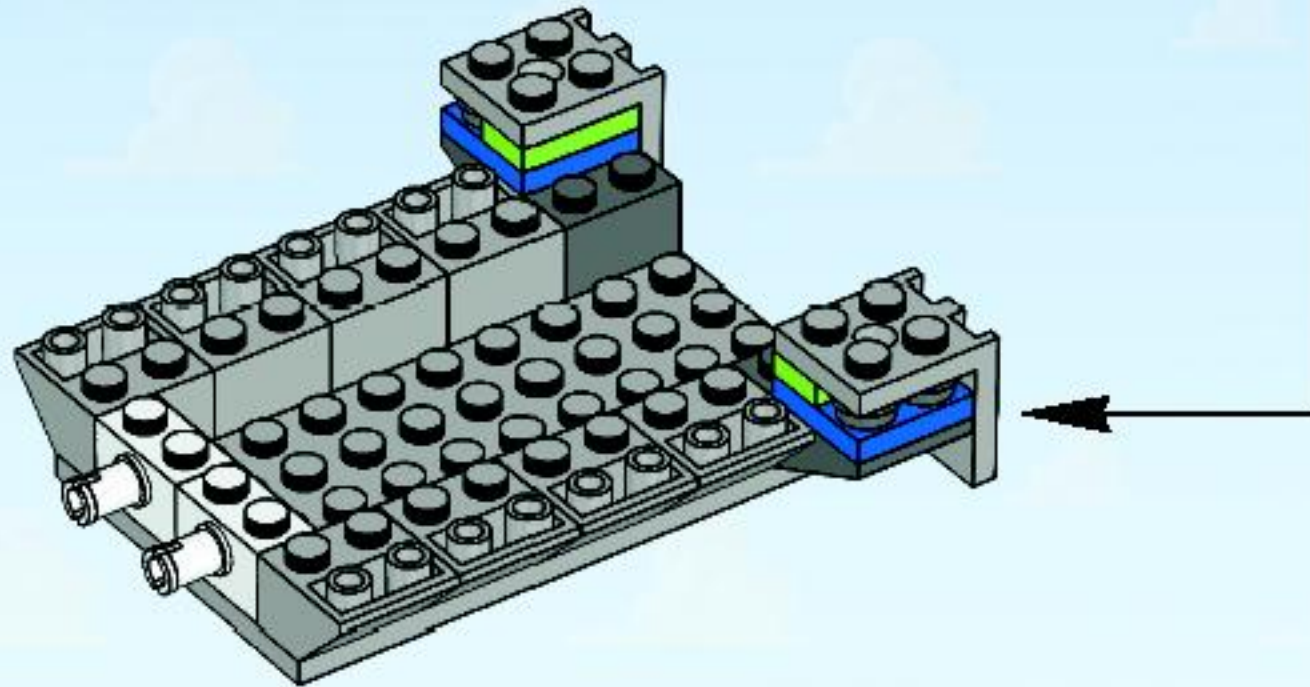
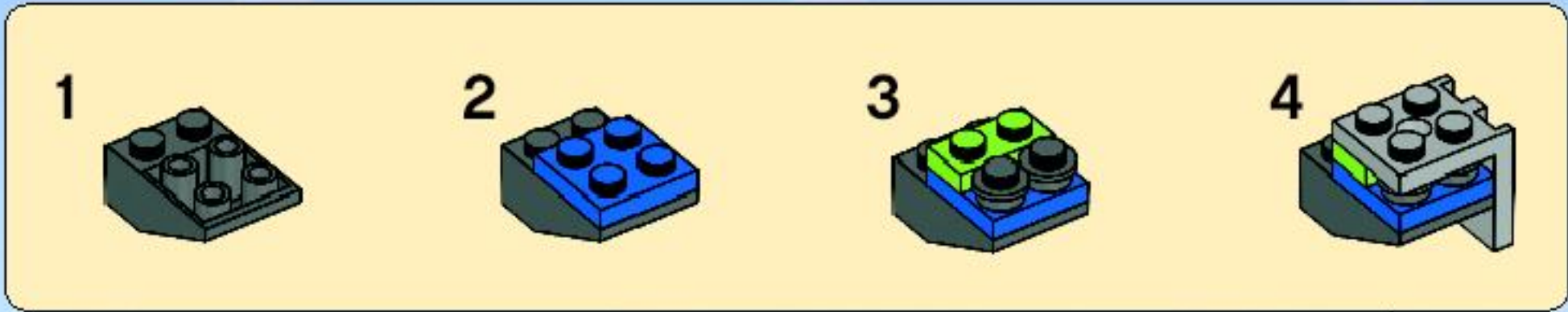



6

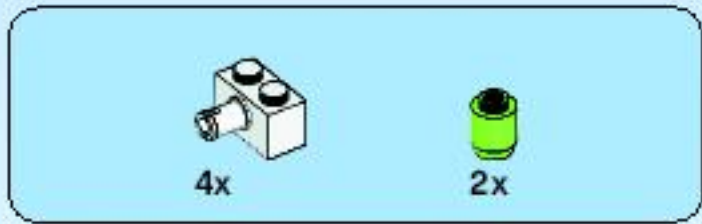
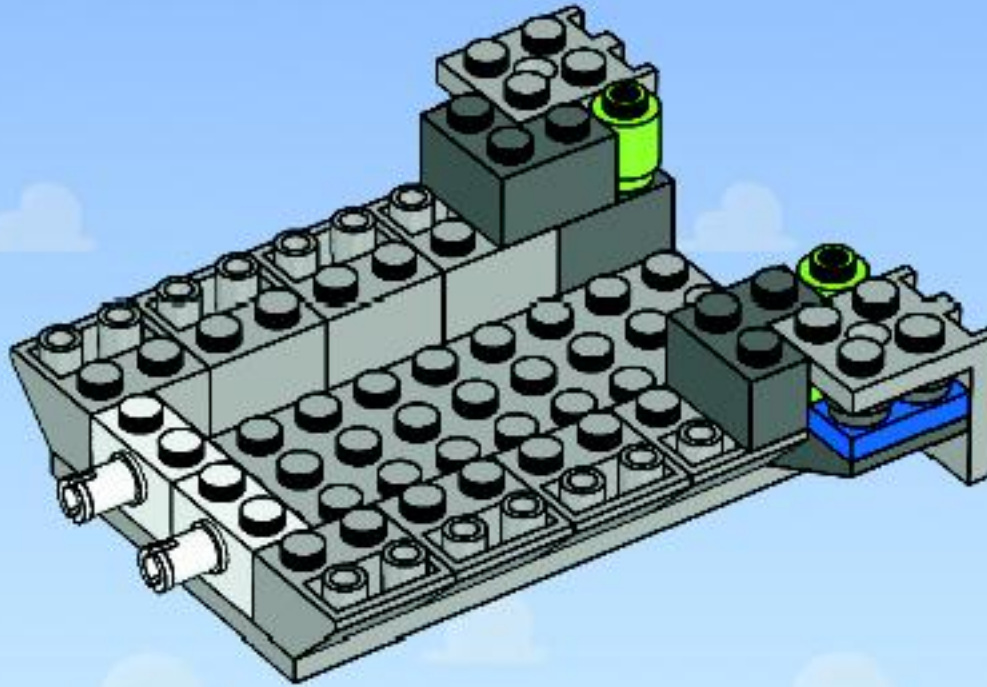

7

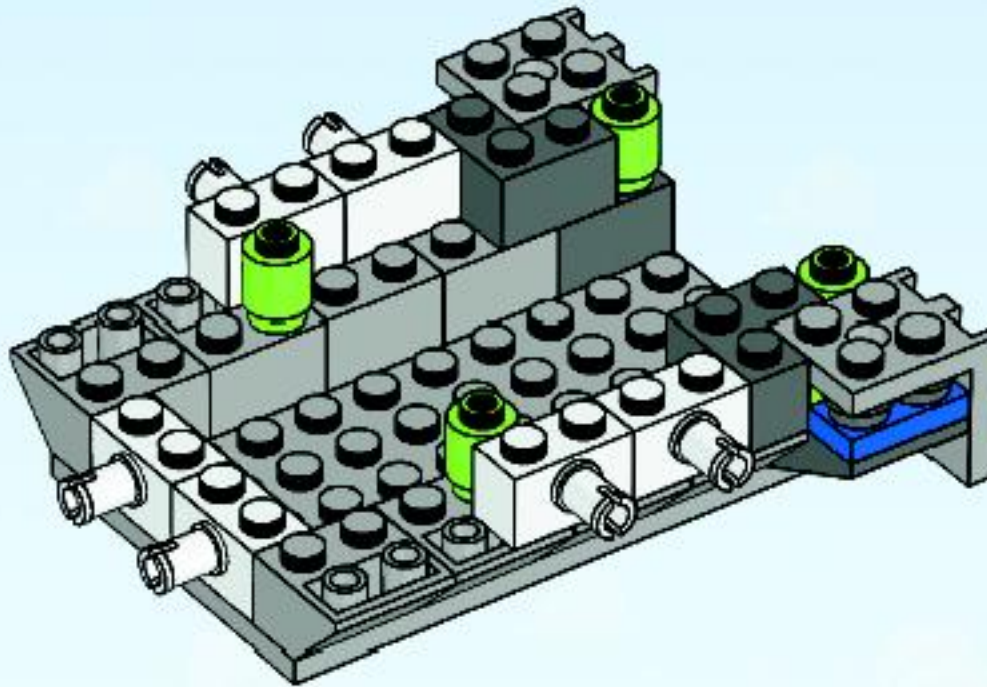

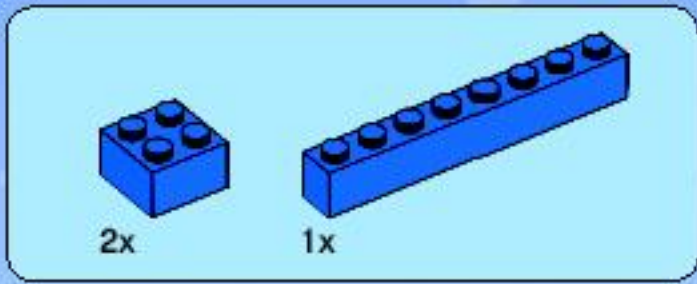

8

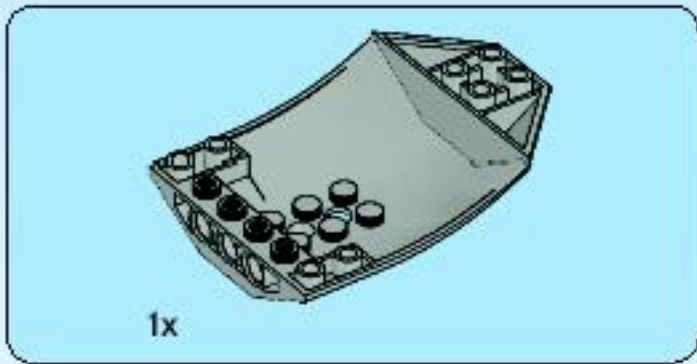
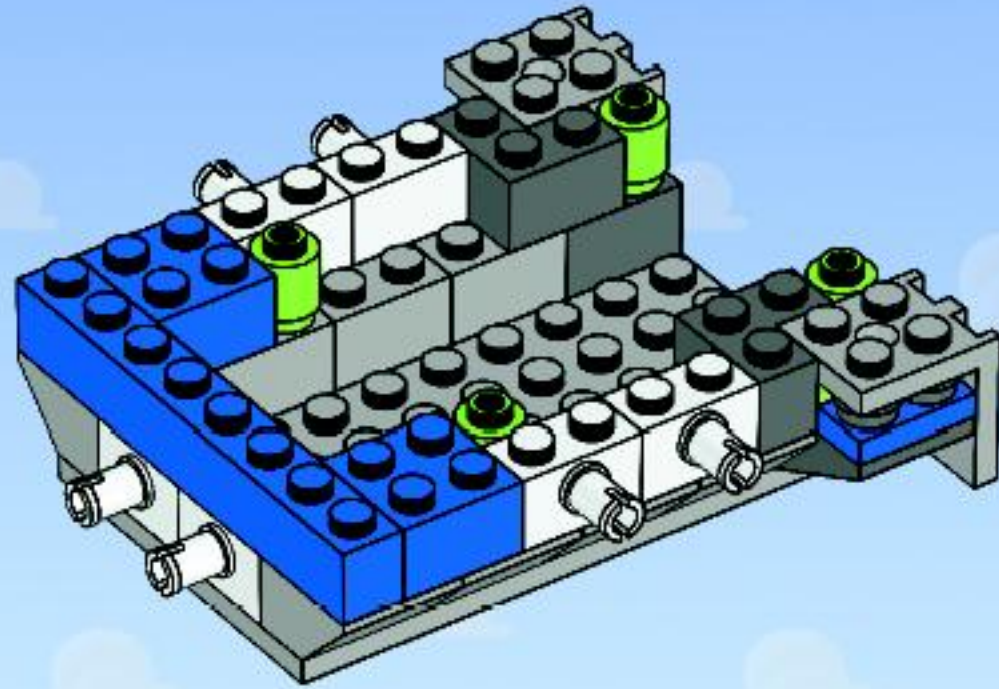

9

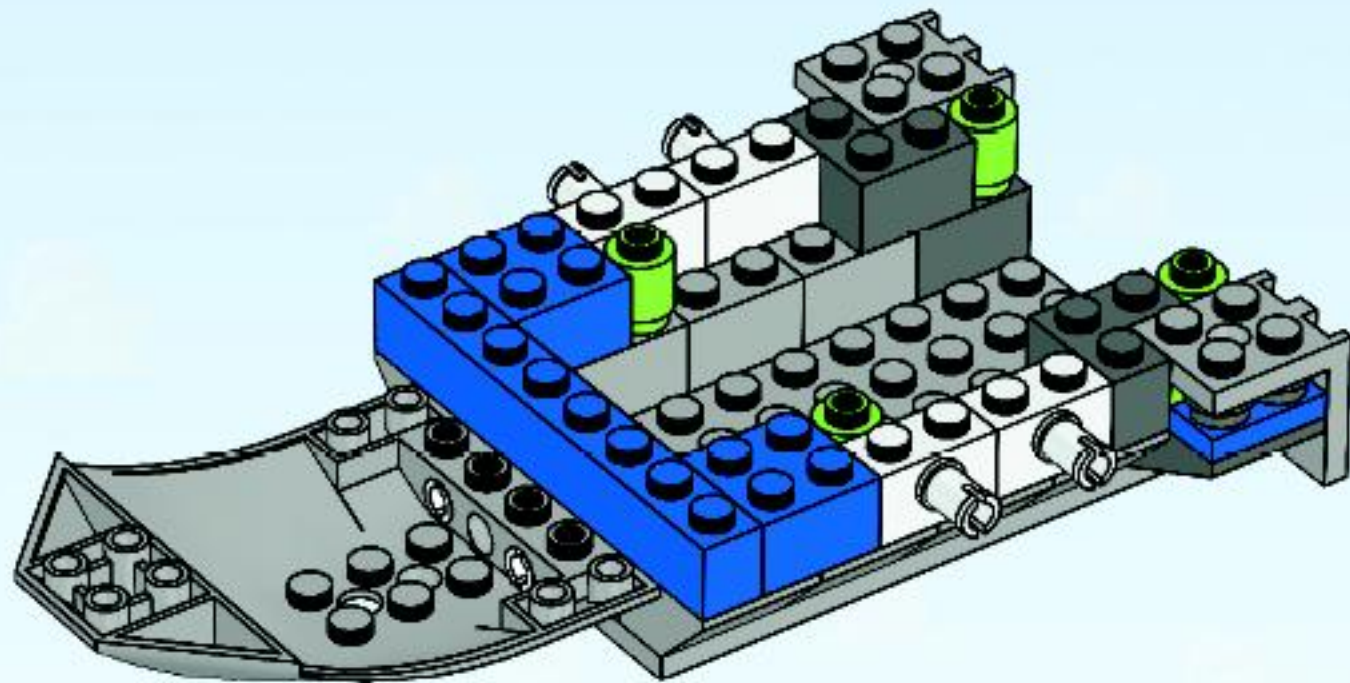



1x

# 10

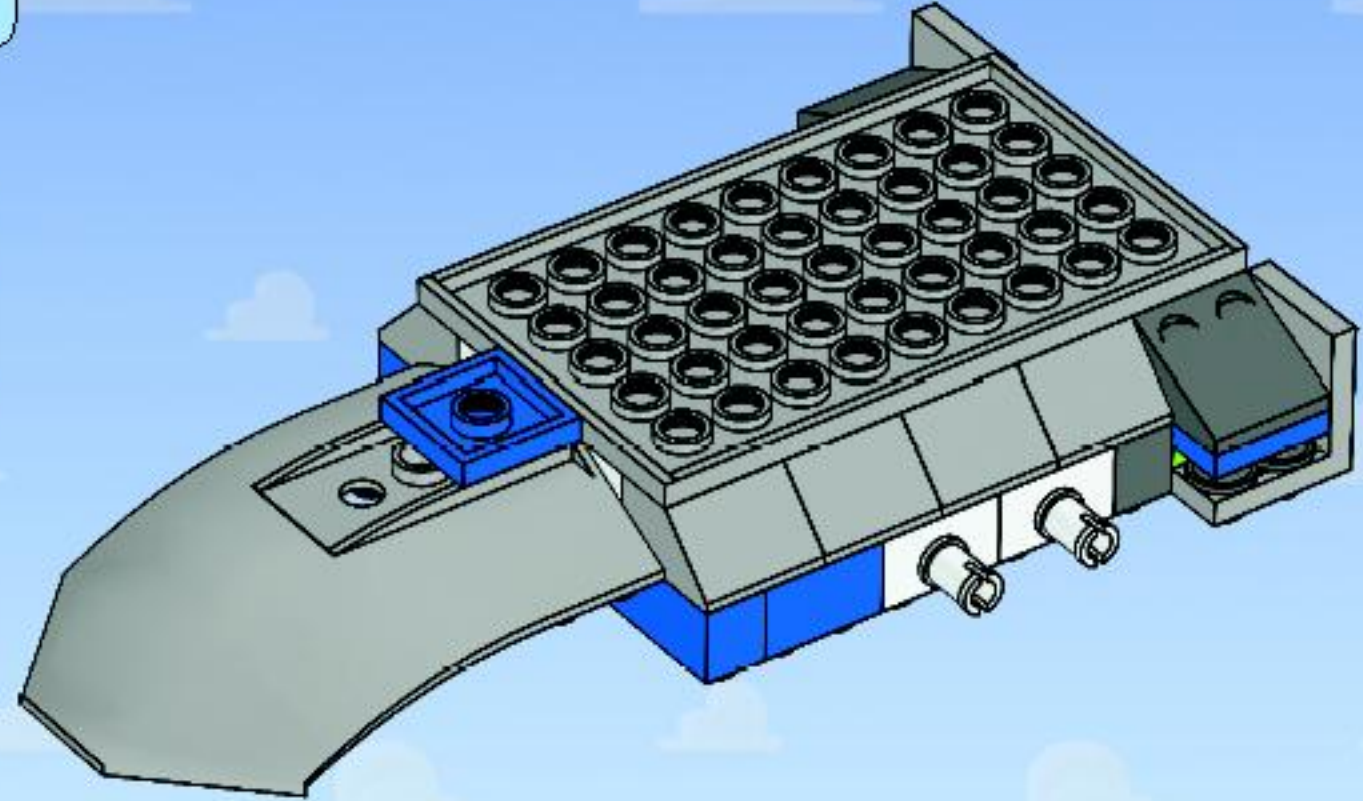

2x

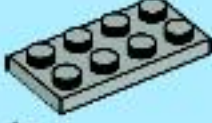

1x

# 11

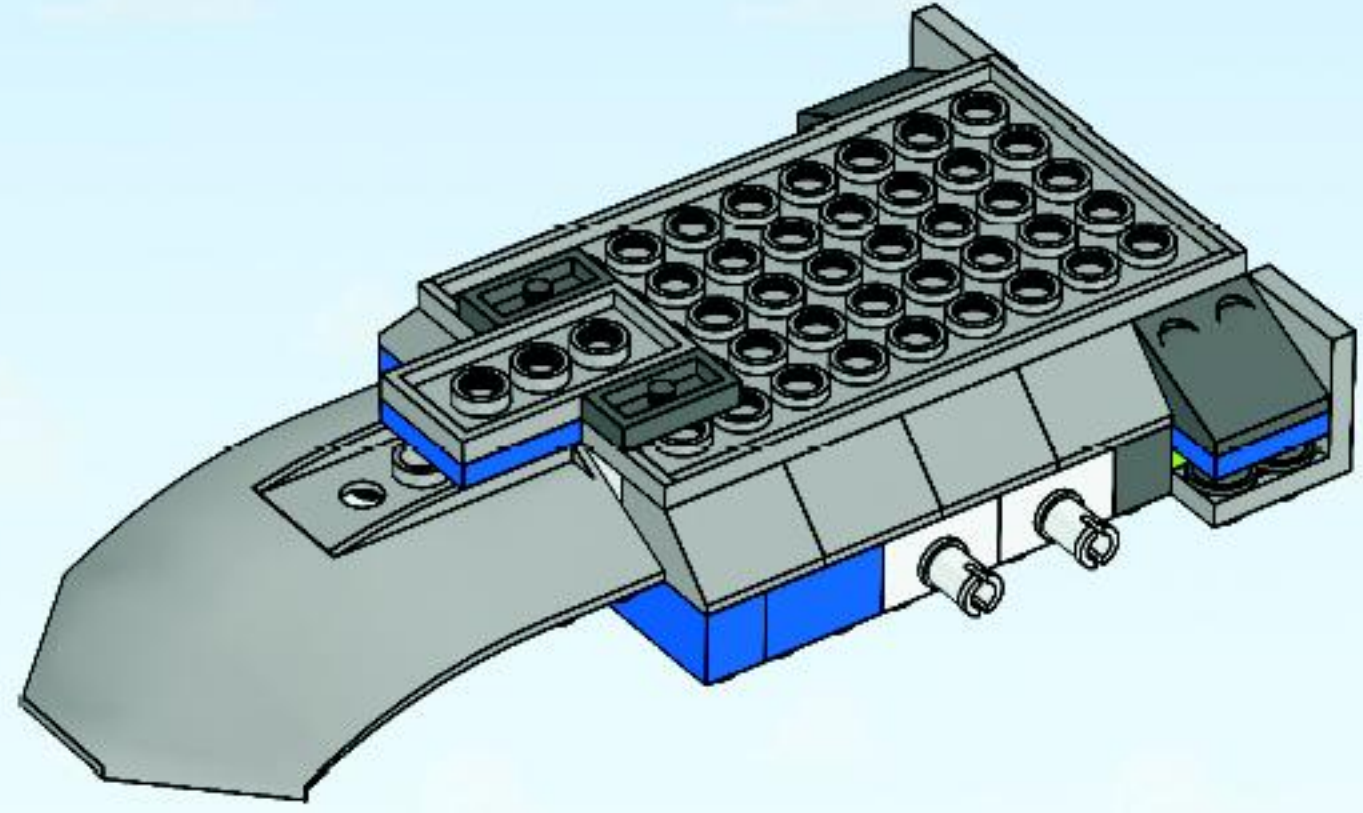



12

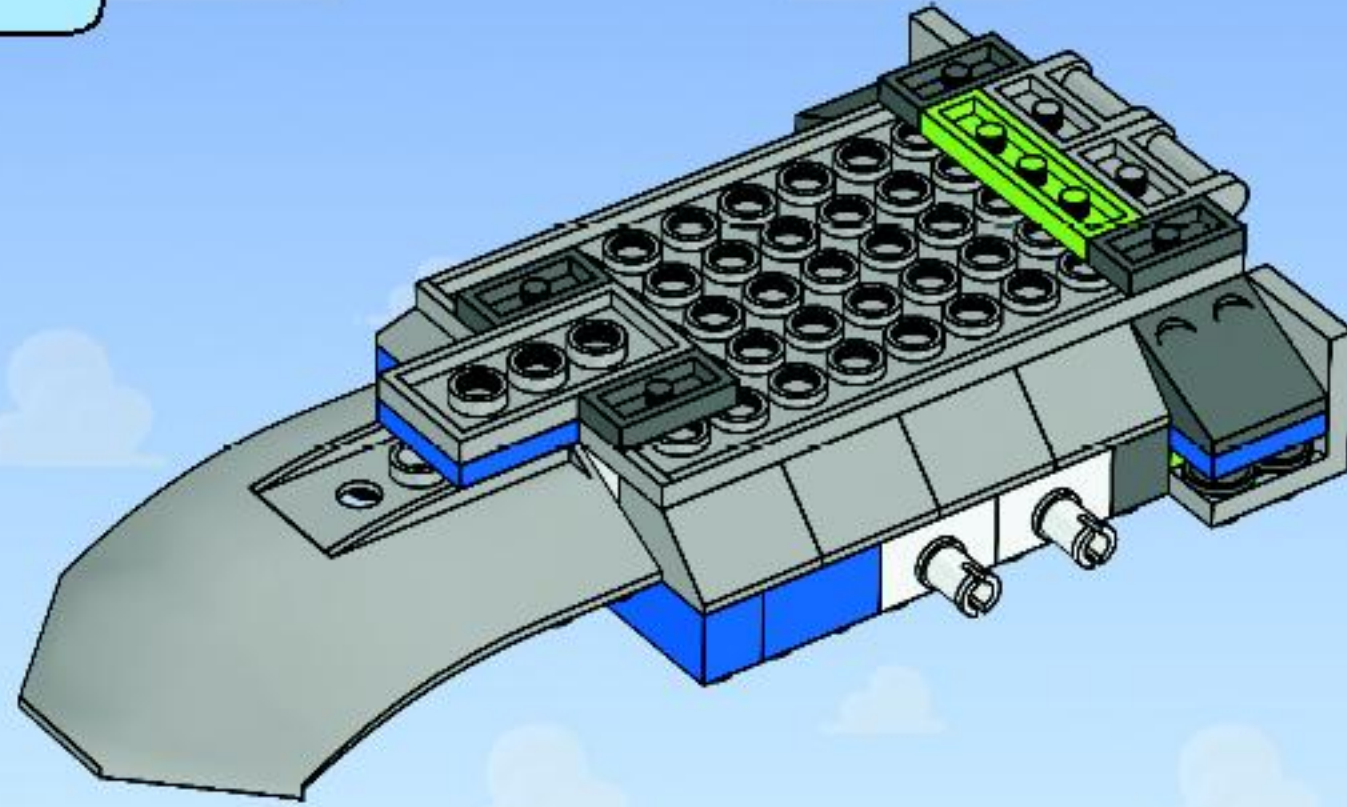

13

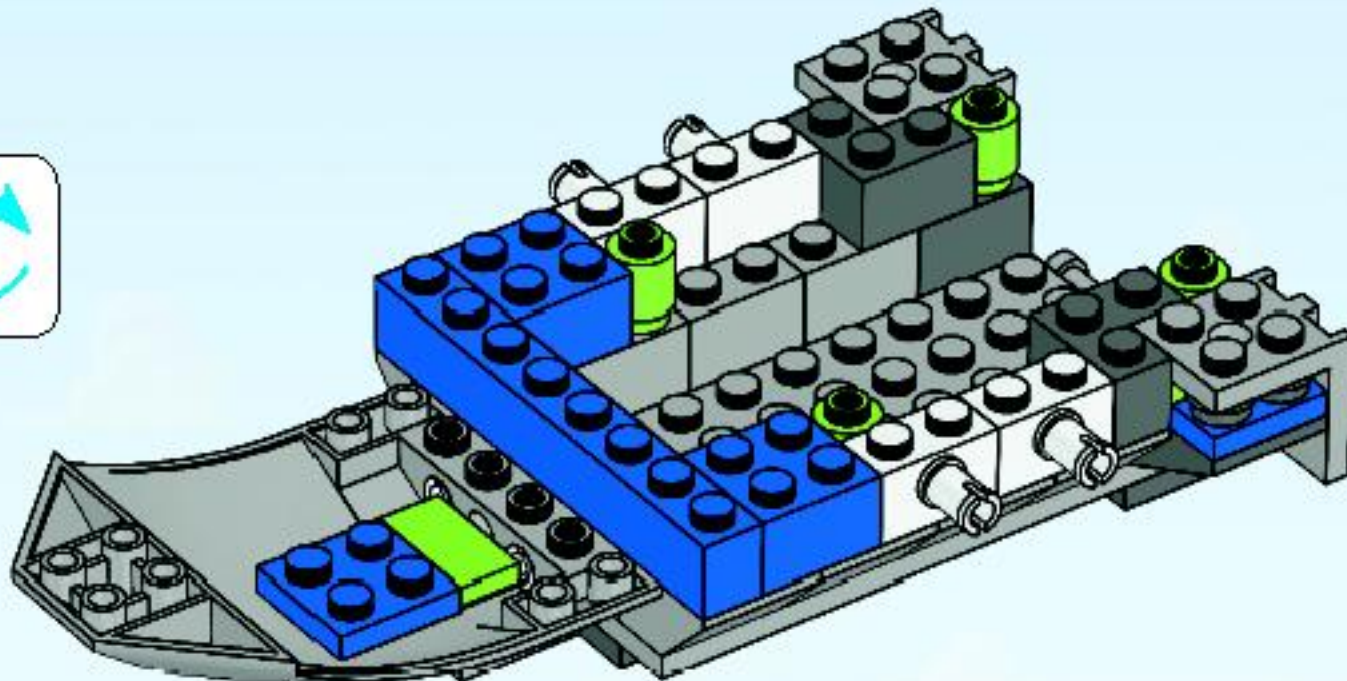



1x

# 14

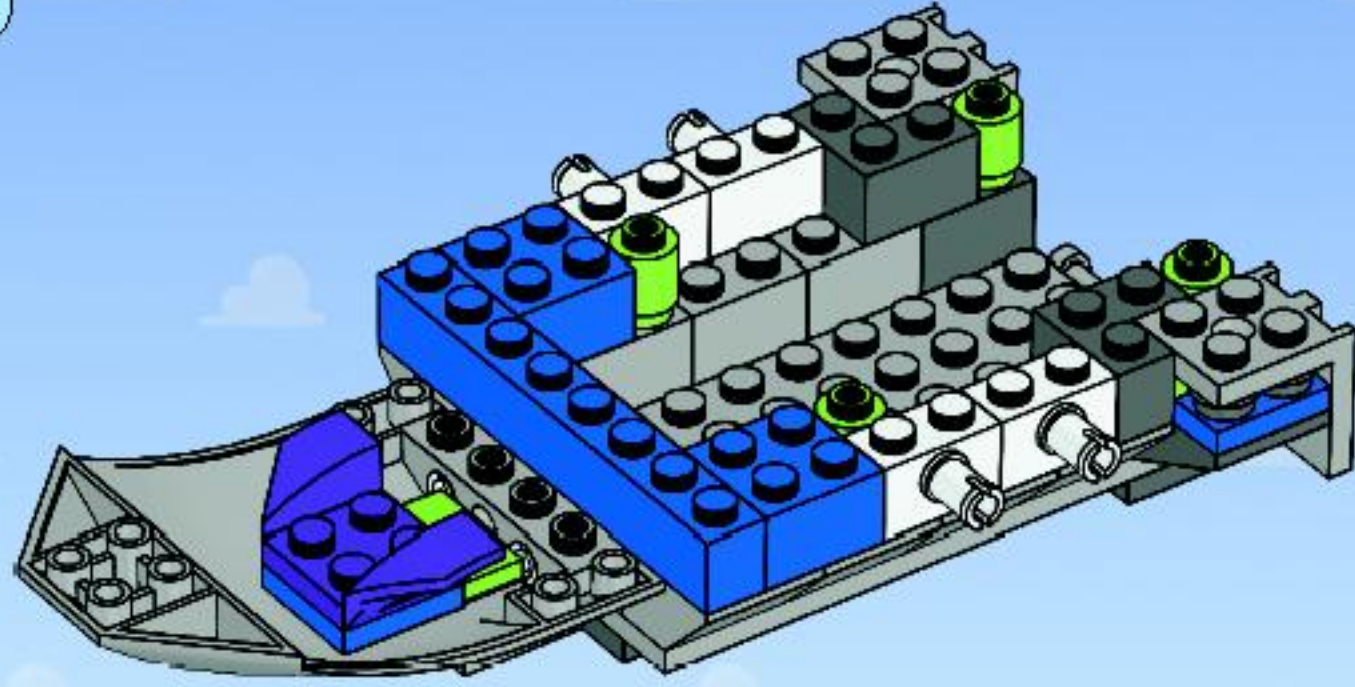

1x



1x

# 15

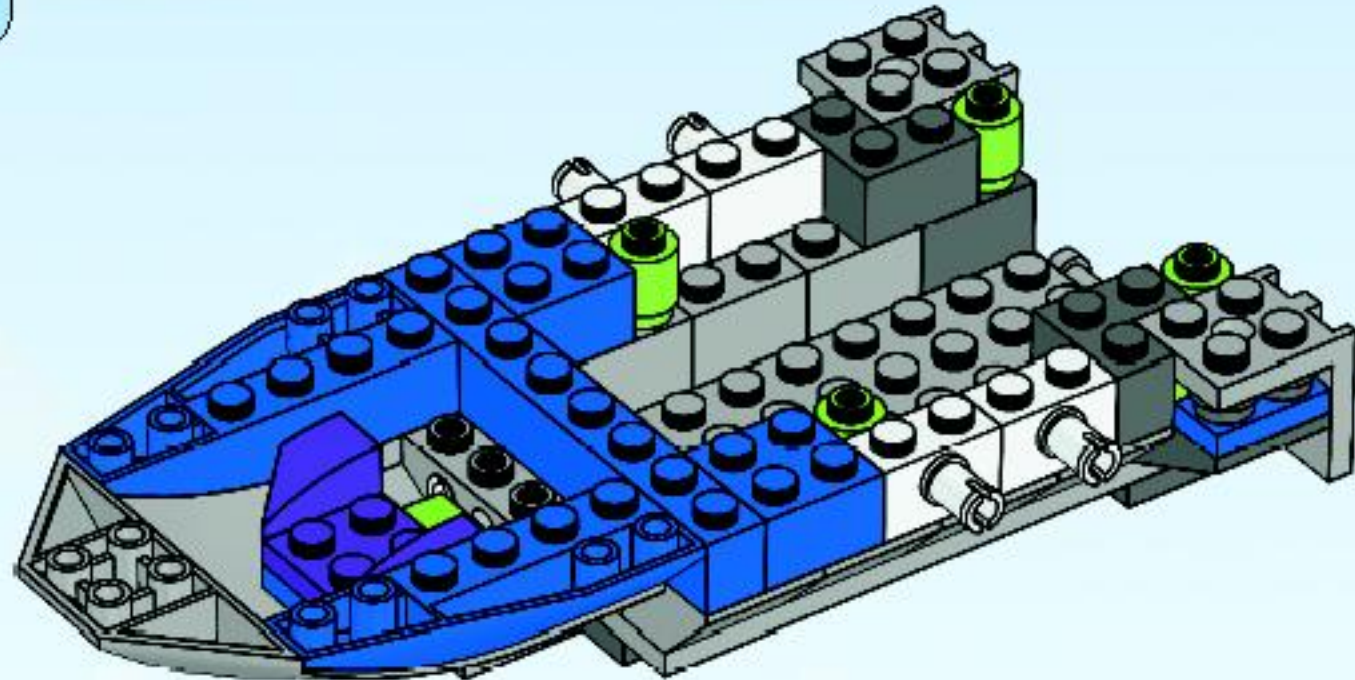



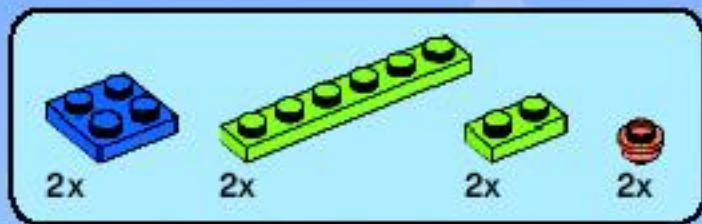

16

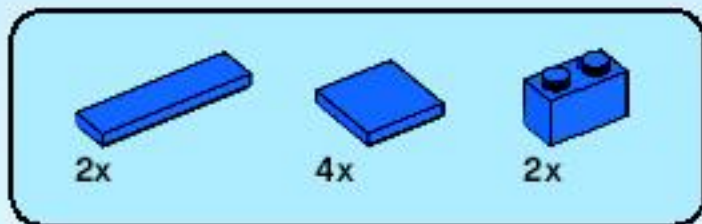
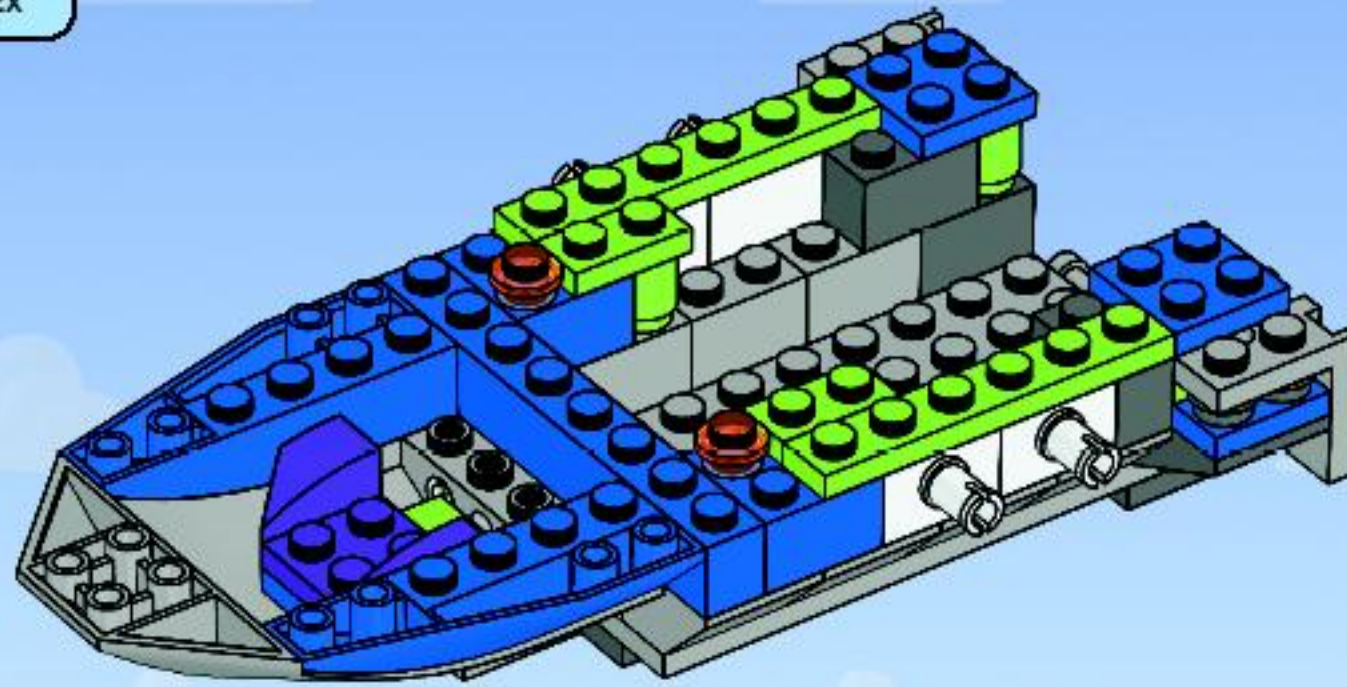

17

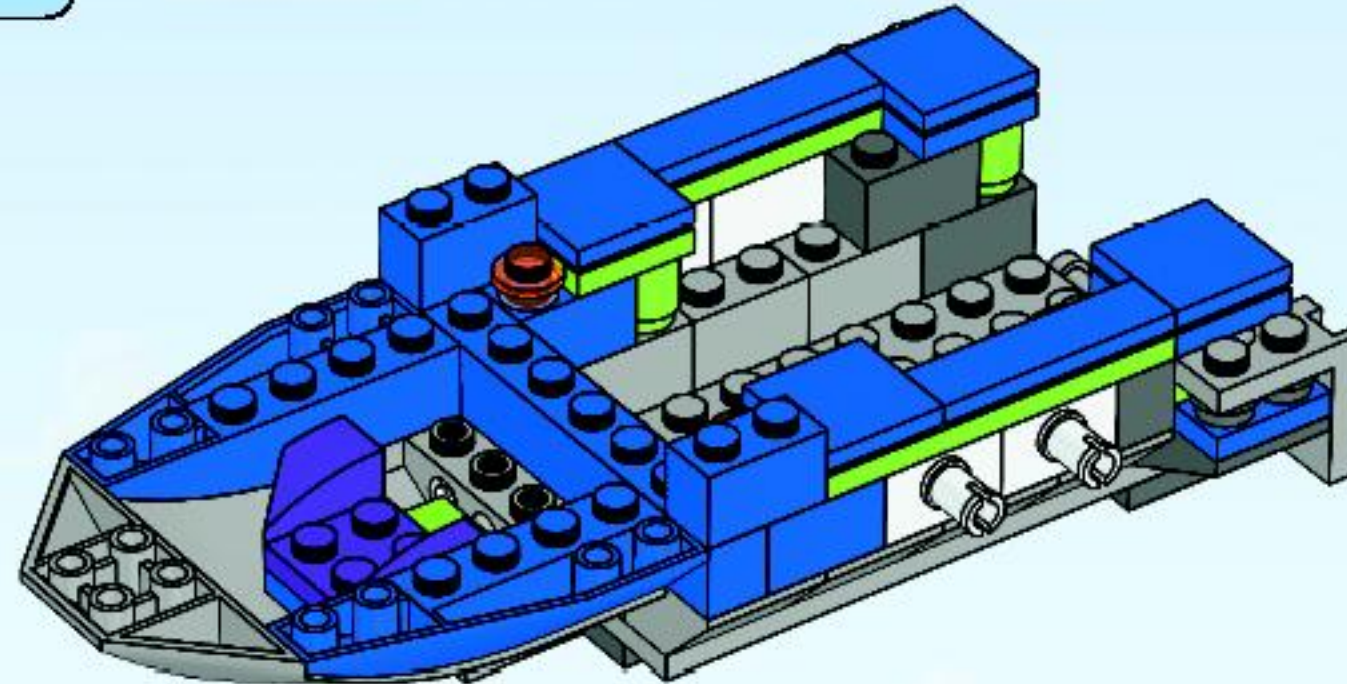



2x



2x

# 18

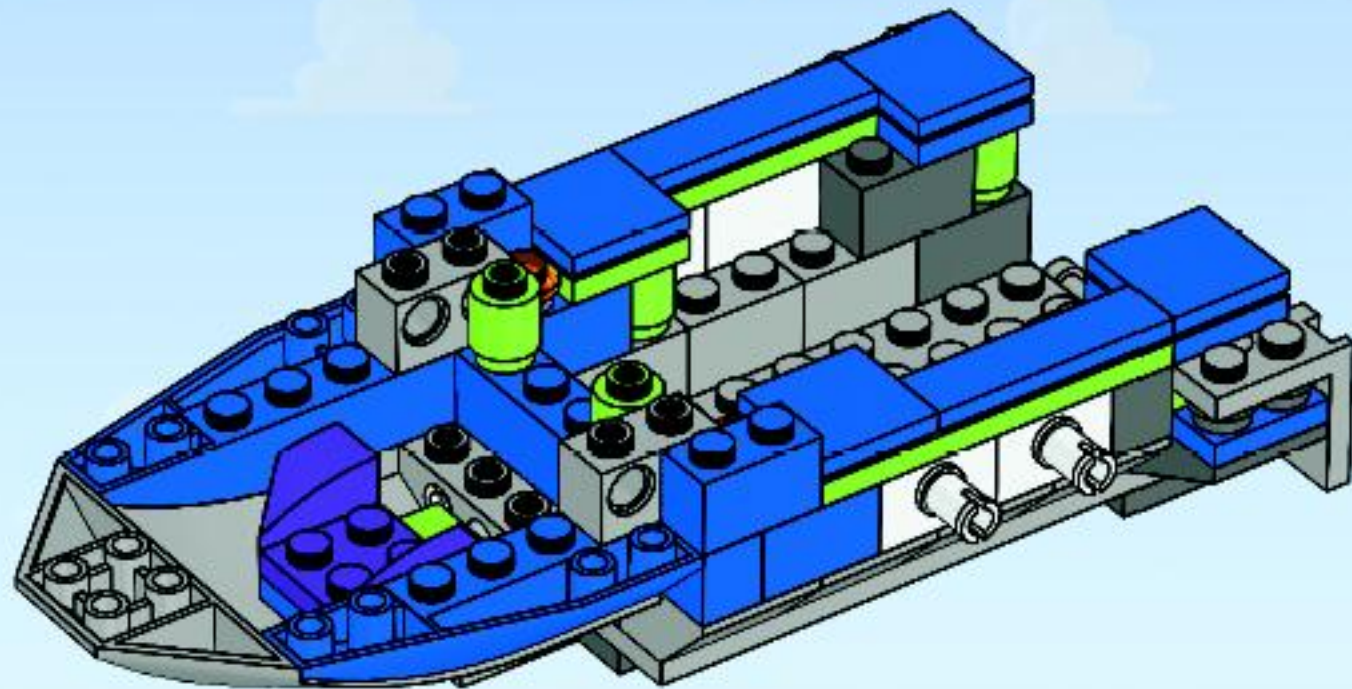



19

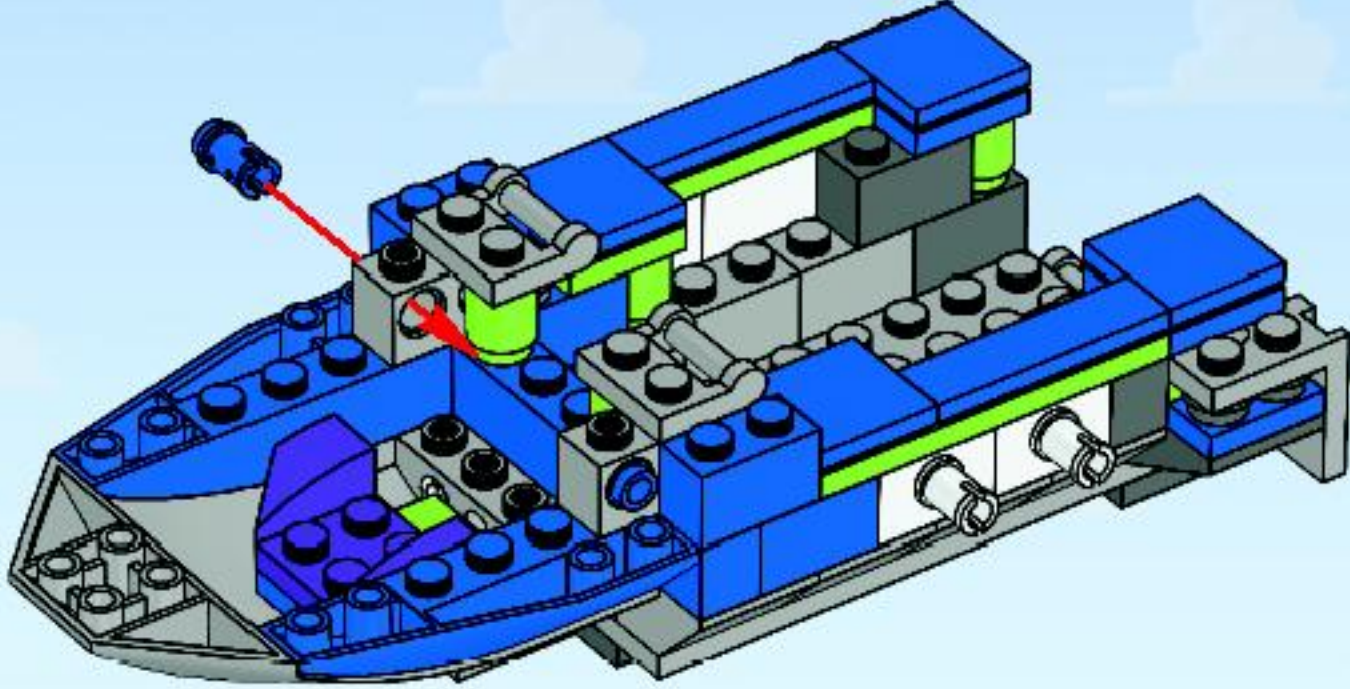

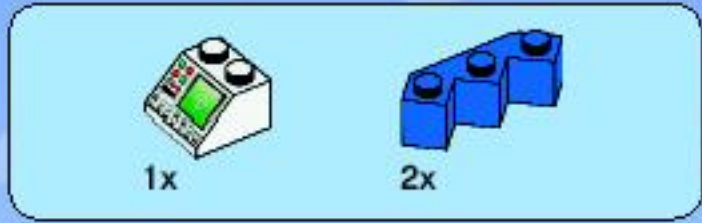

20

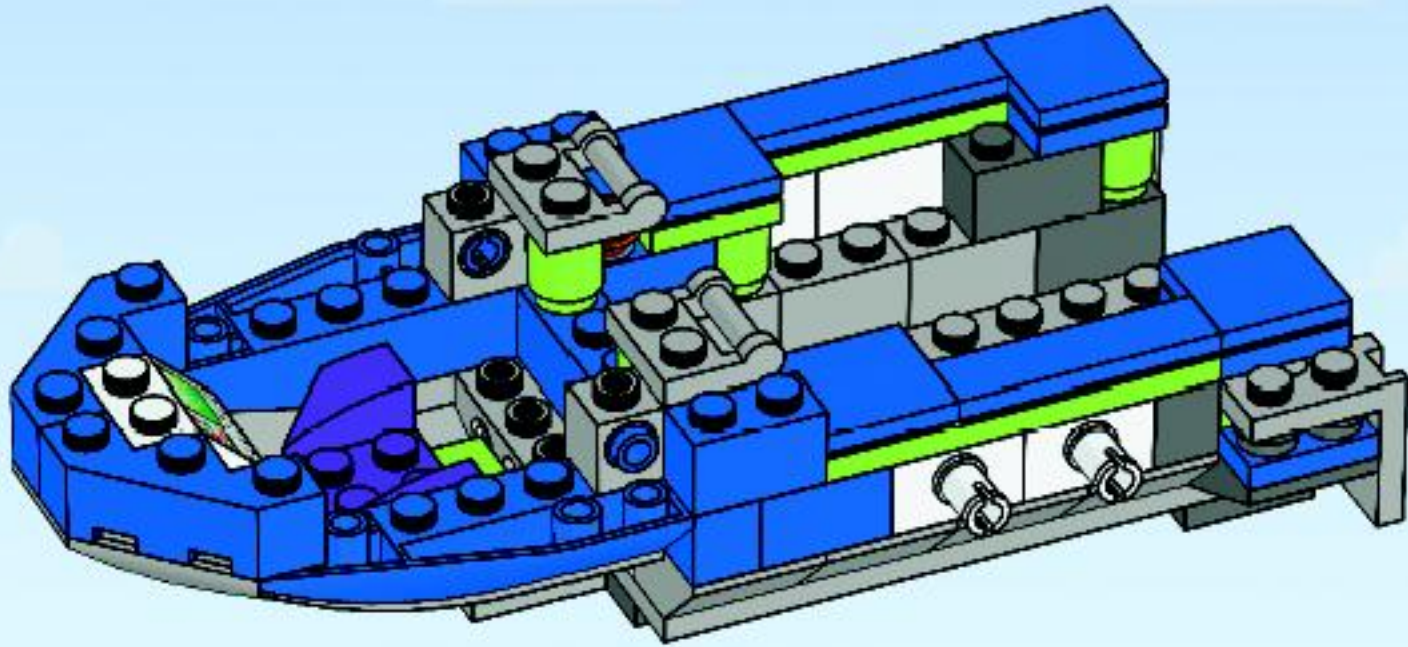



2x



2x

# 21

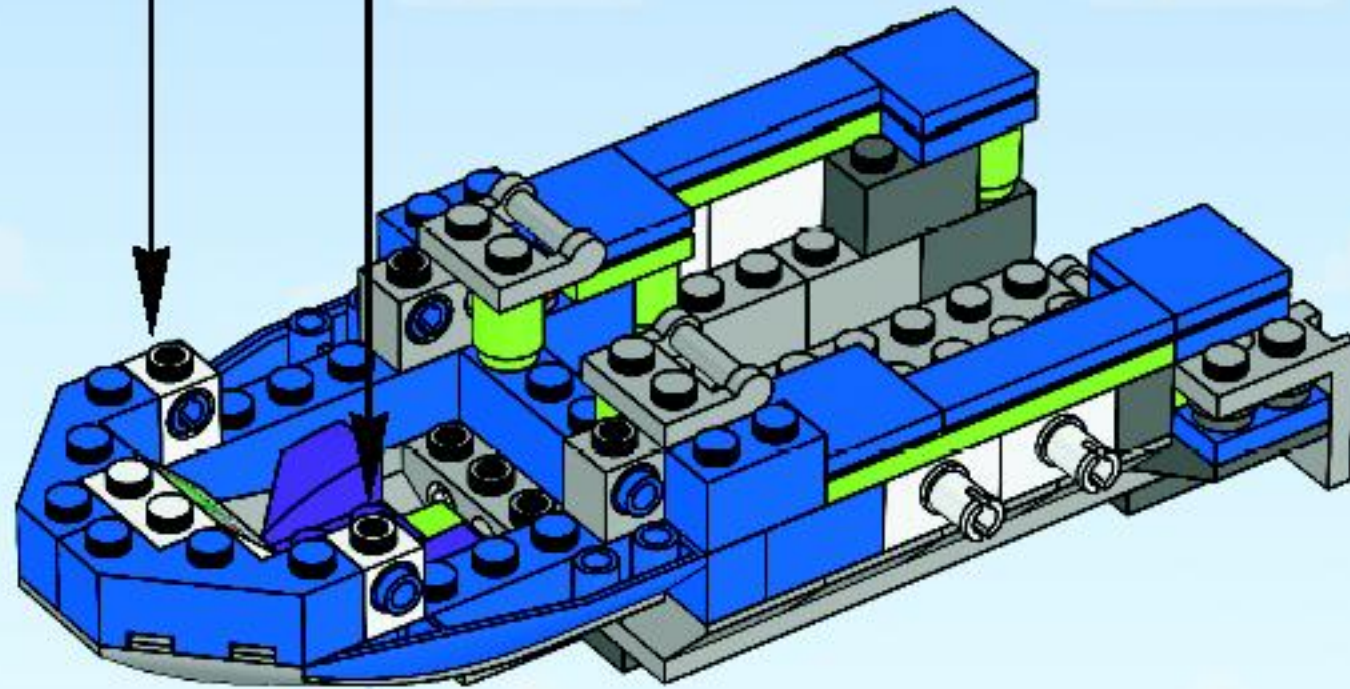
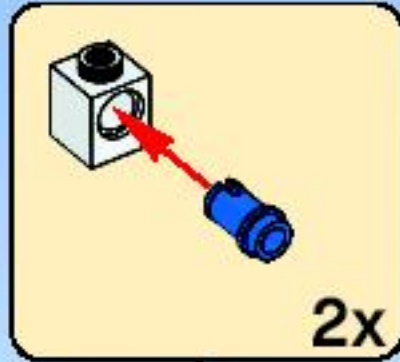

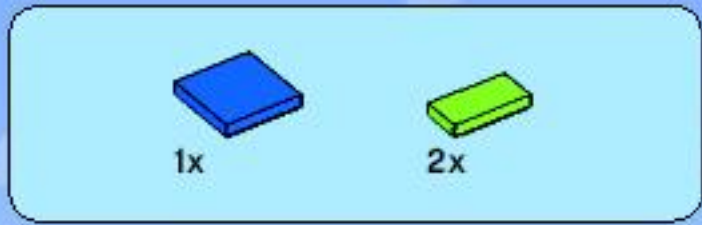

22

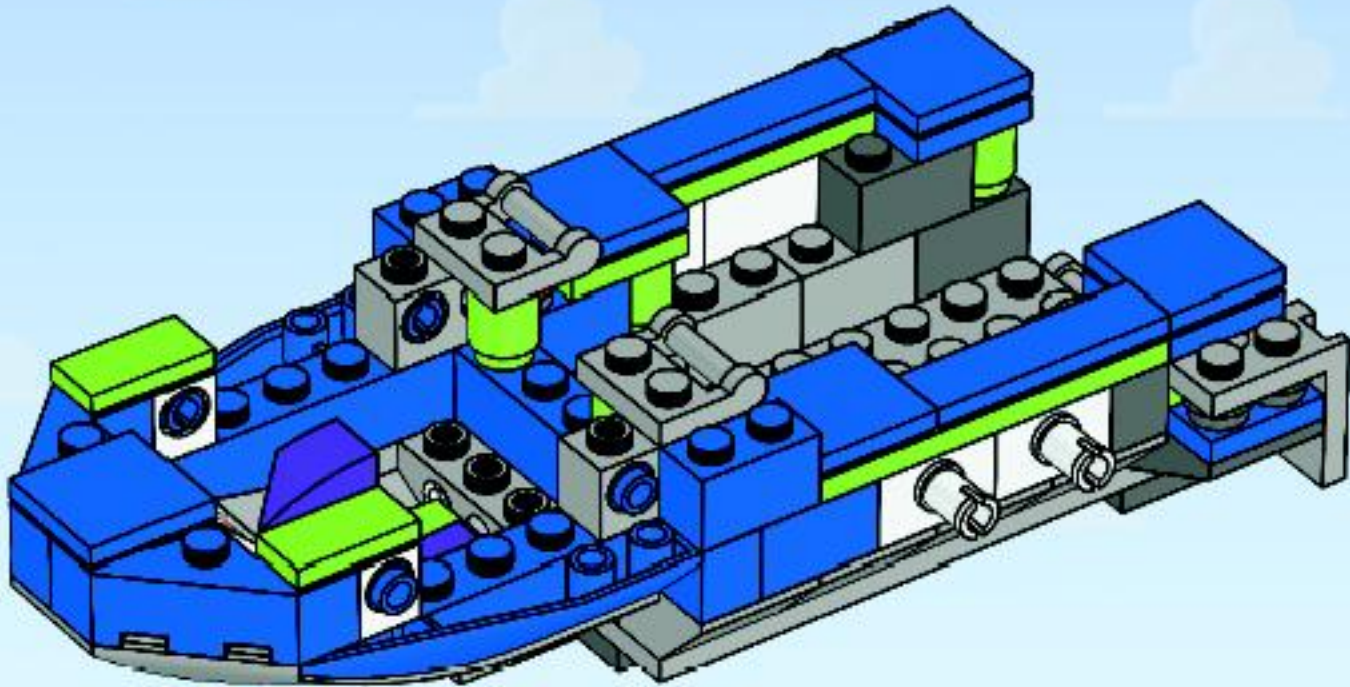

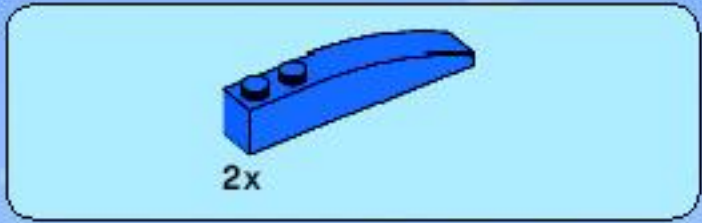

23

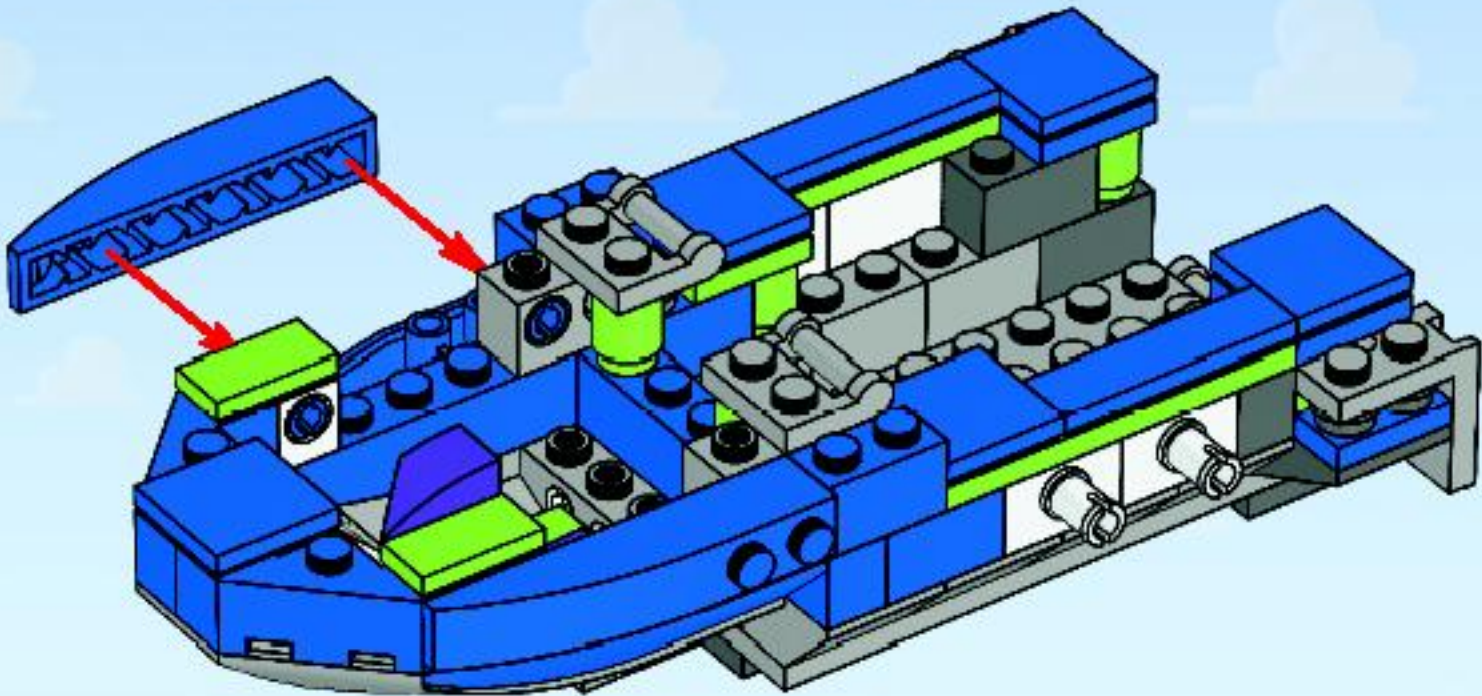



# 24

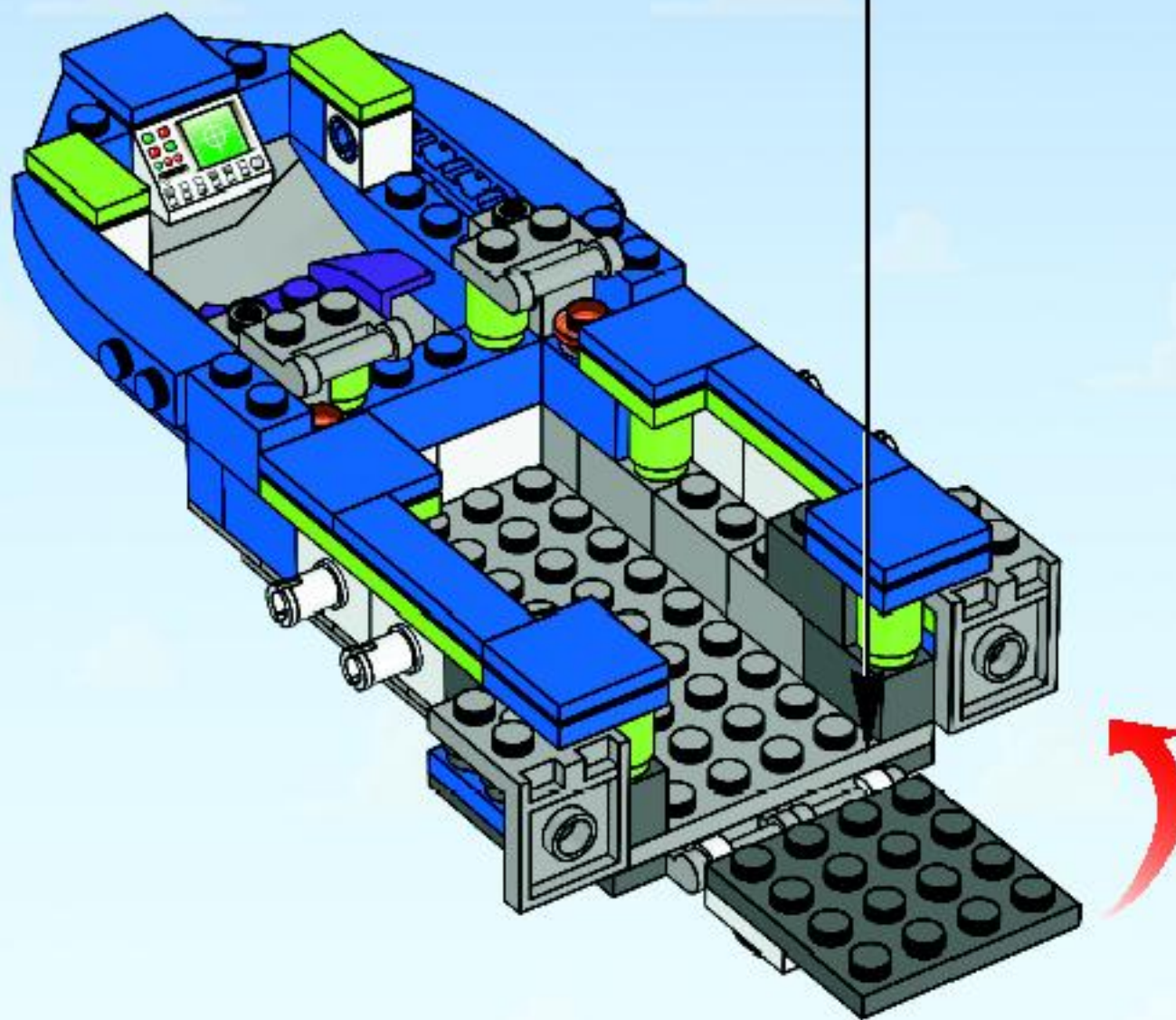
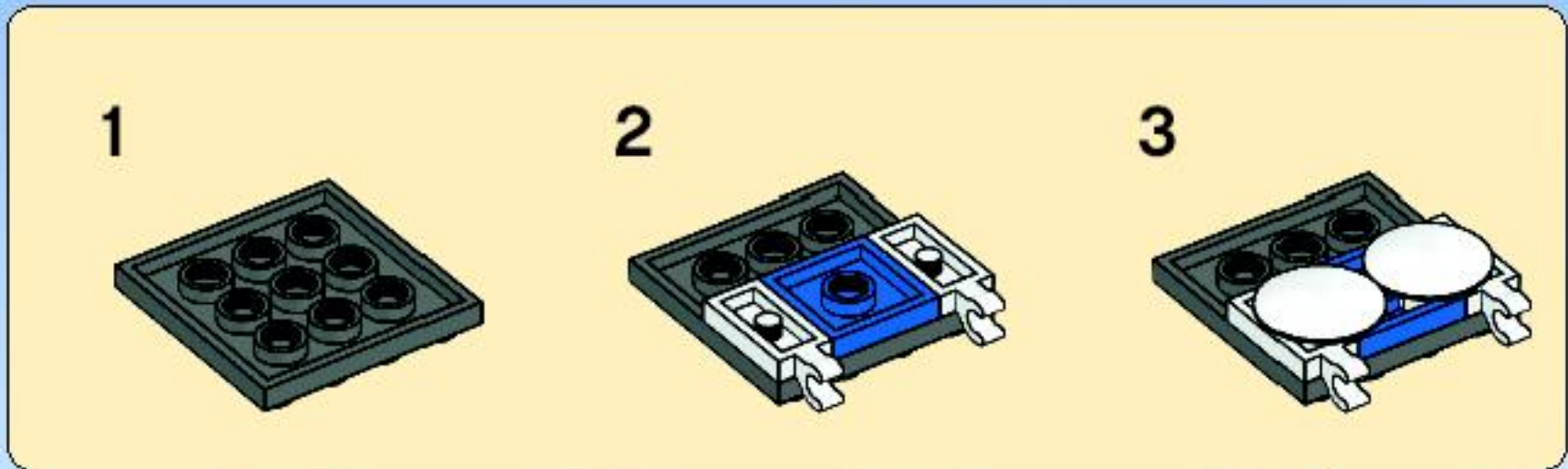



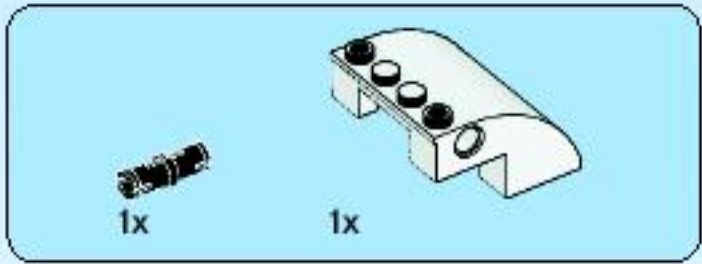
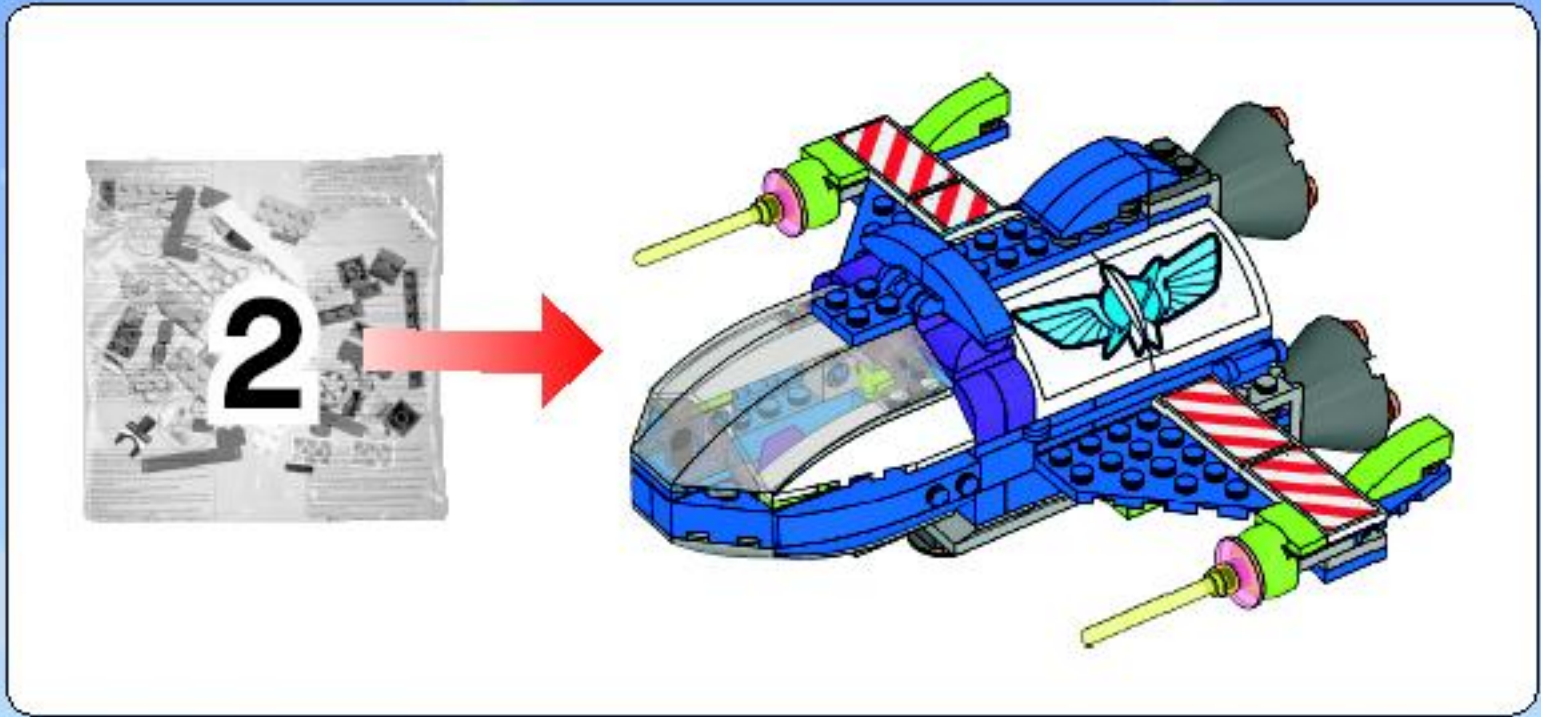

1

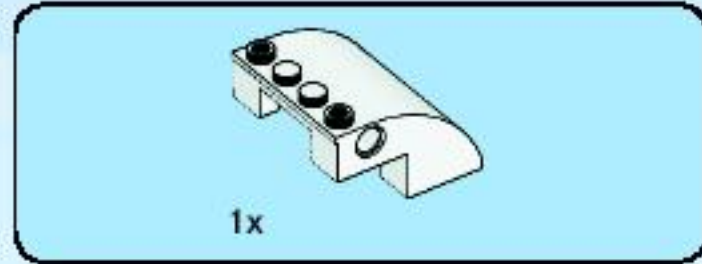
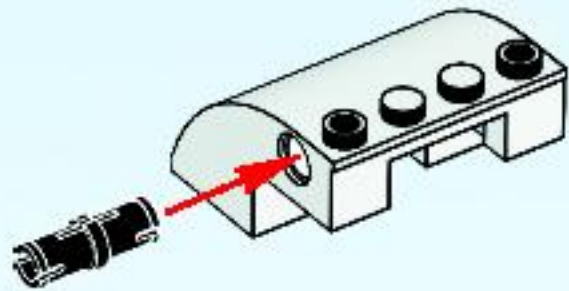

2

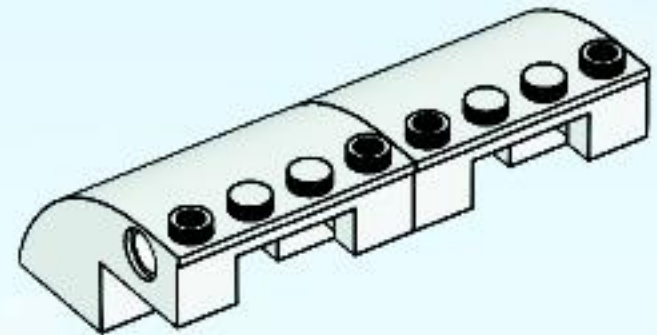

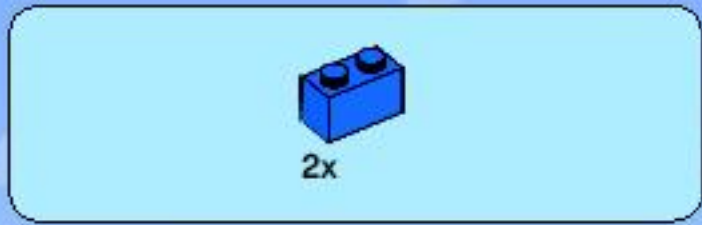

3

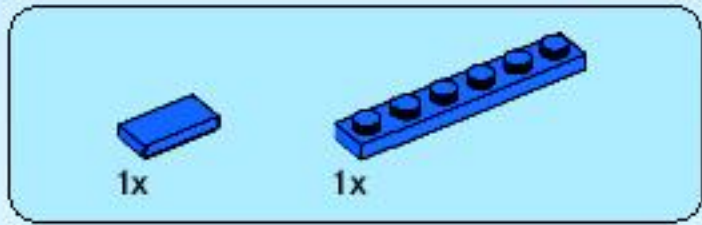
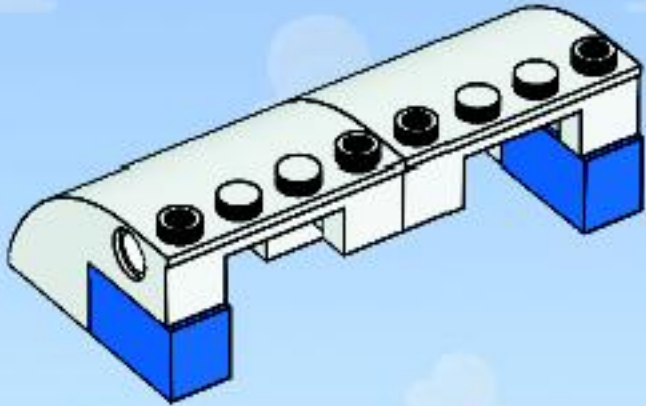

4

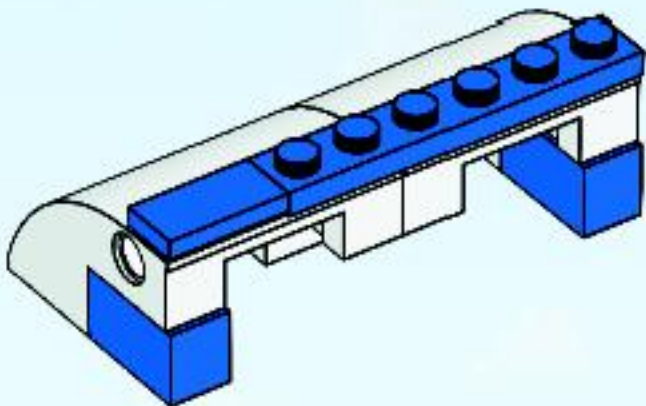

5

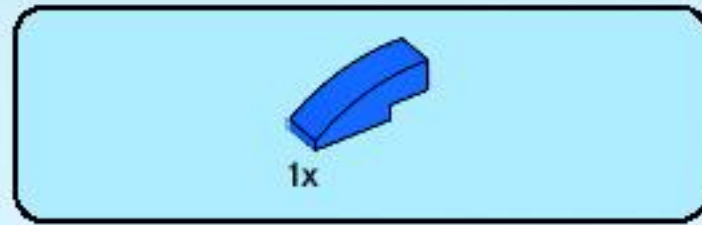
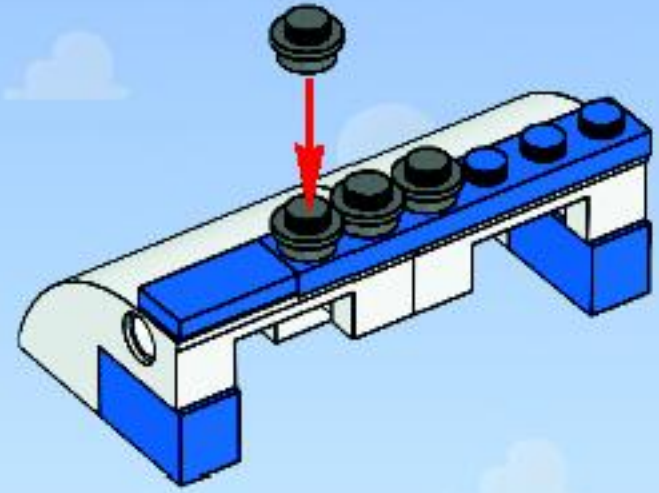

6

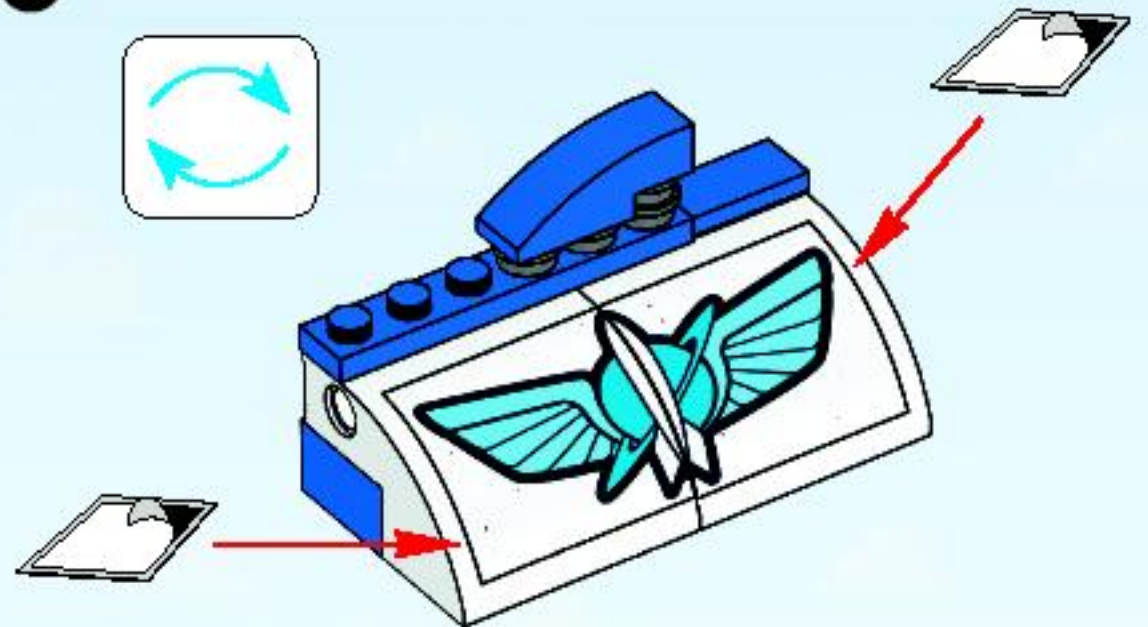

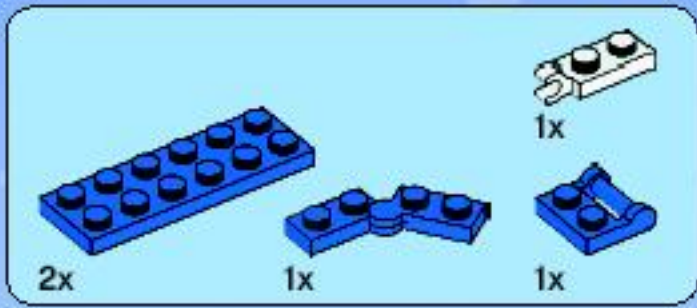

7

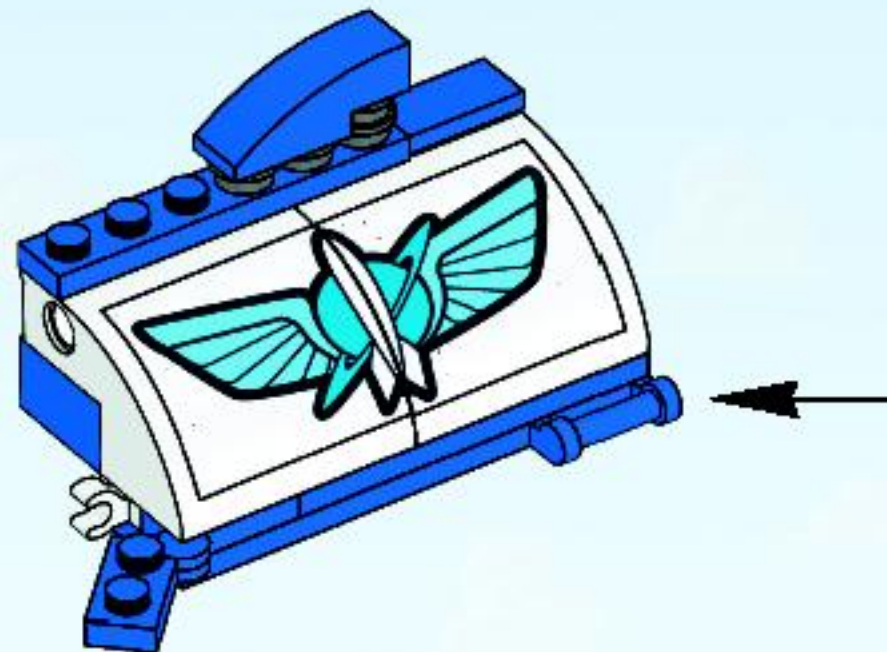
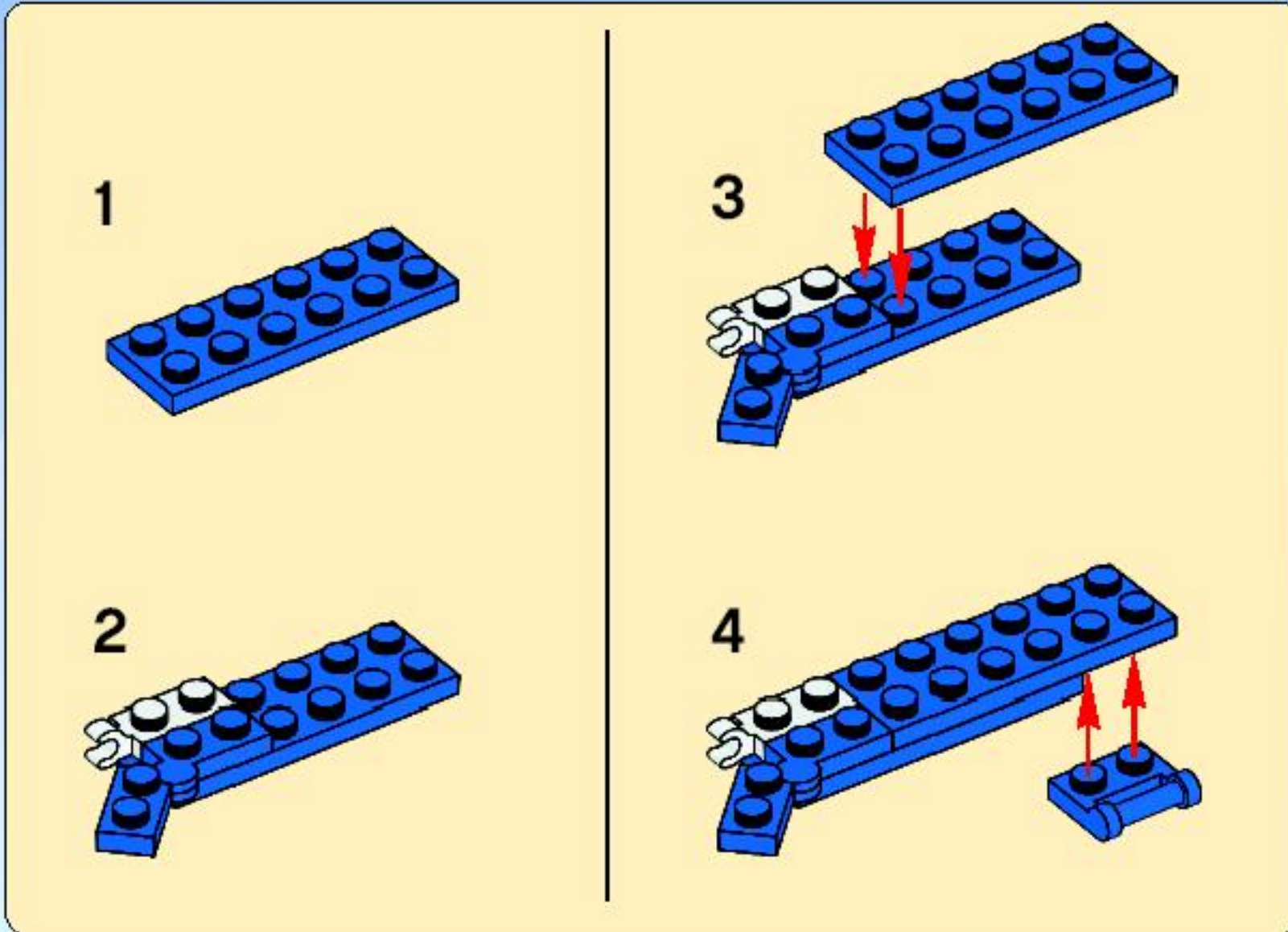

25

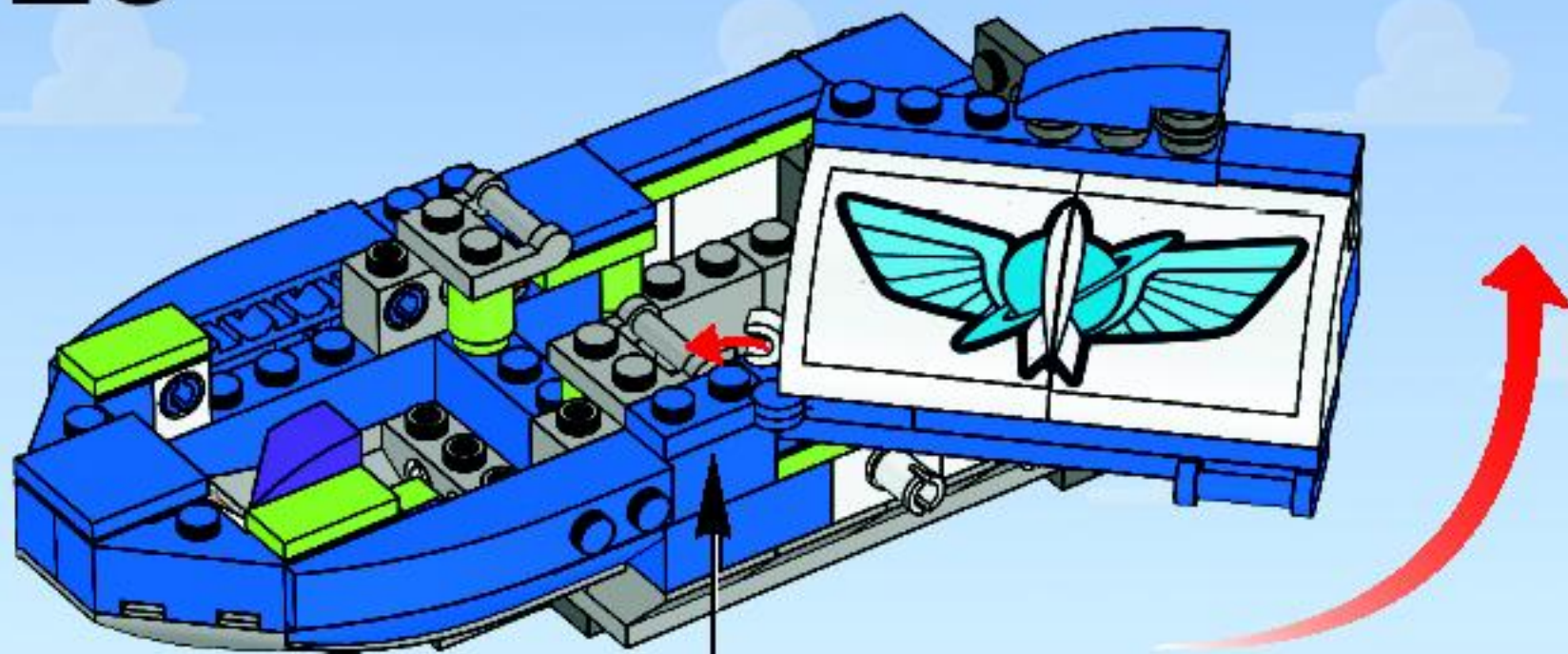

CLICK!



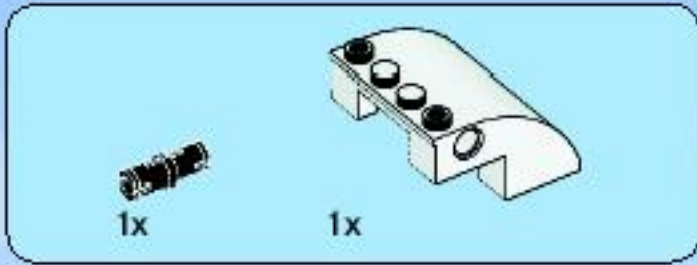
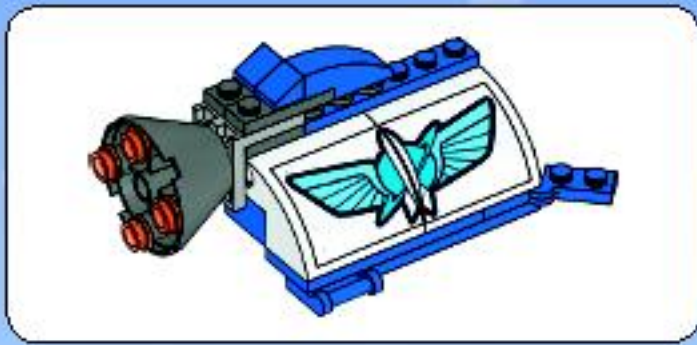

1

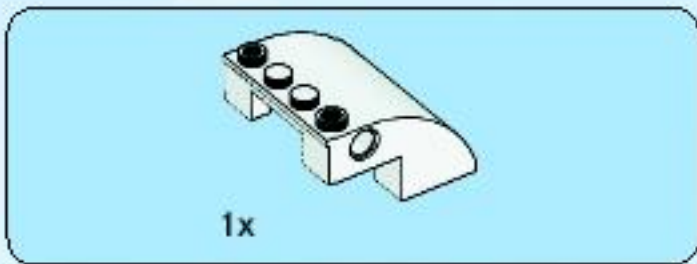
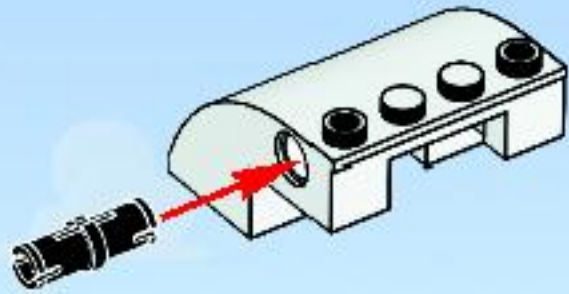

2

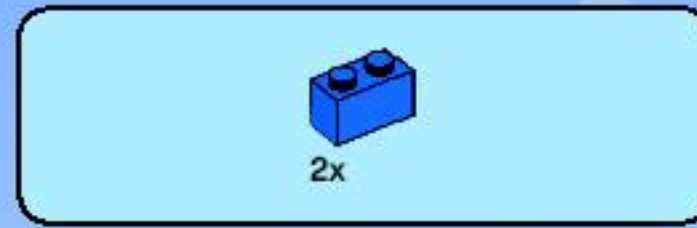
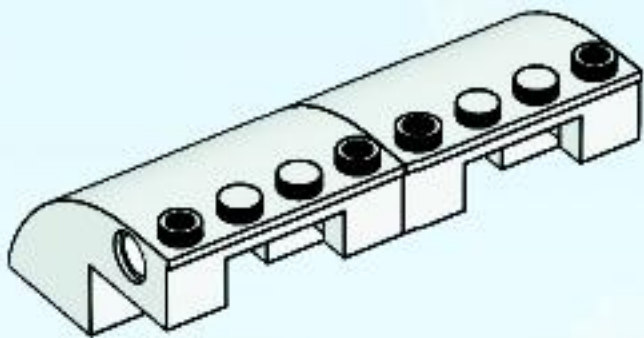

3

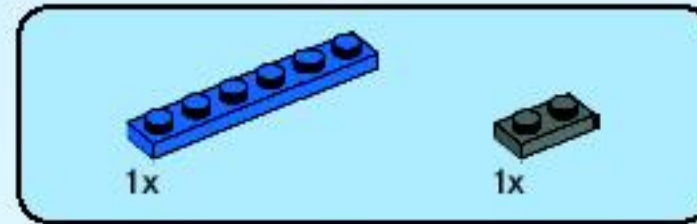
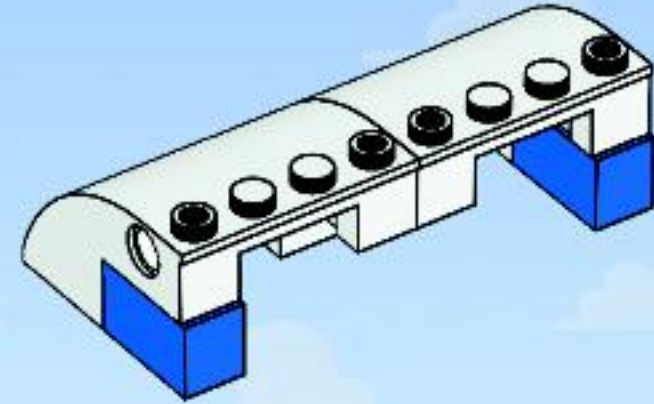

4

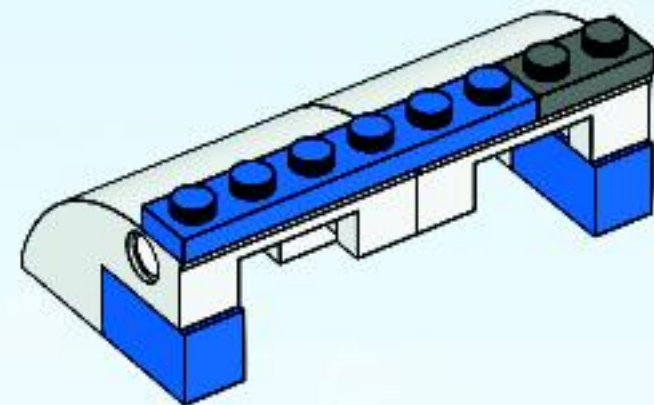

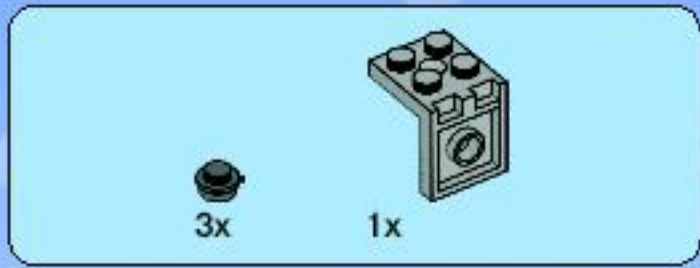

5

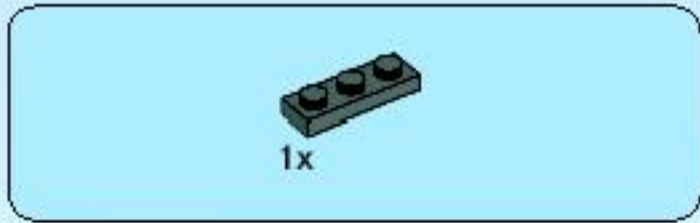
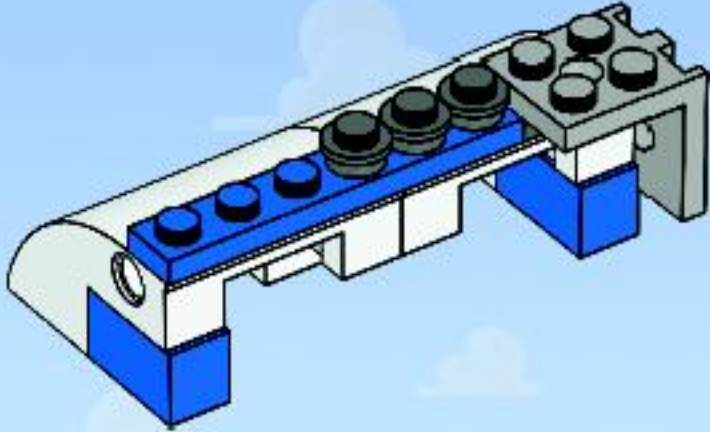

6

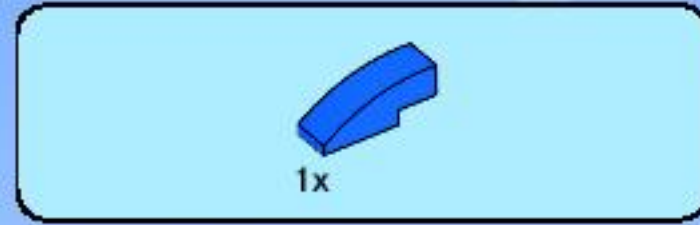
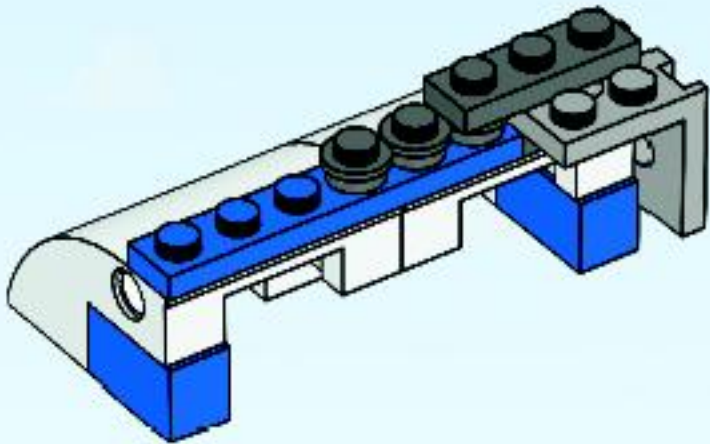

7

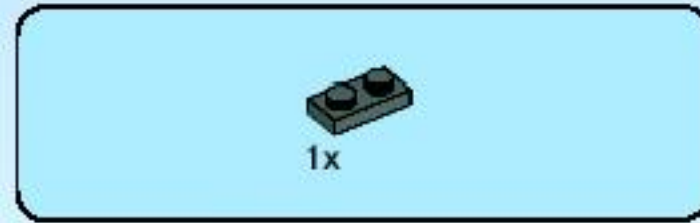
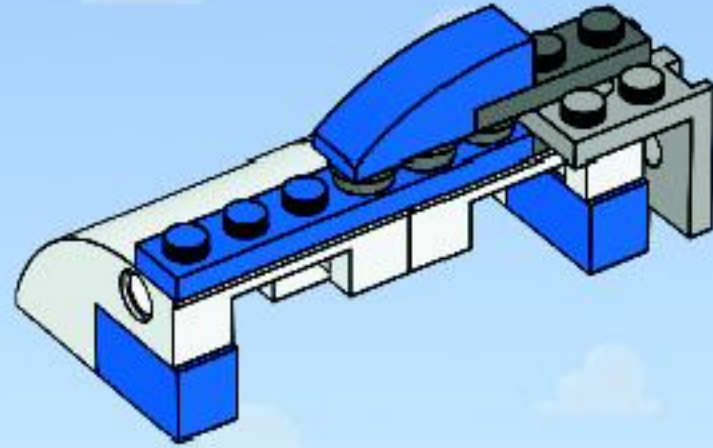

8

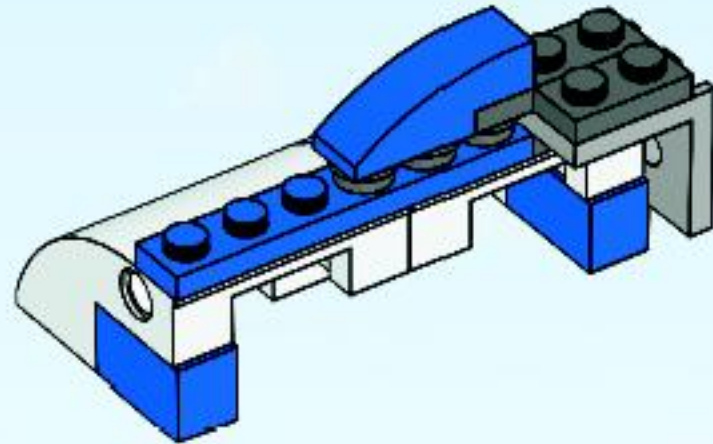



9

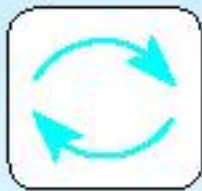
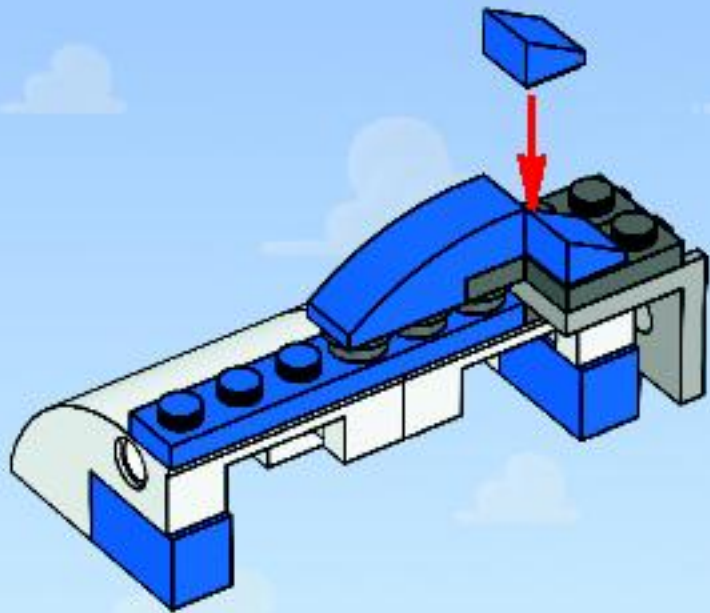

10

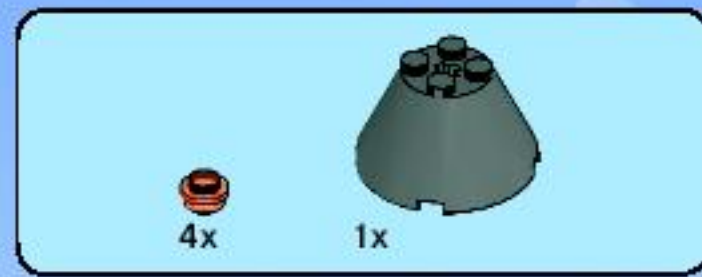
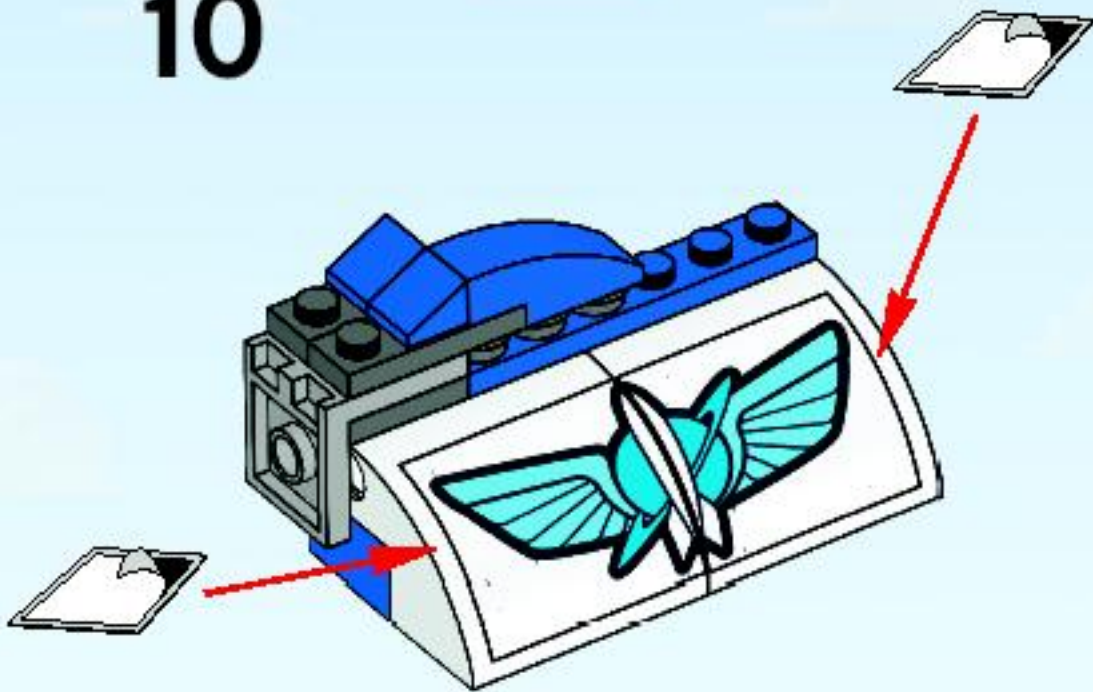

11

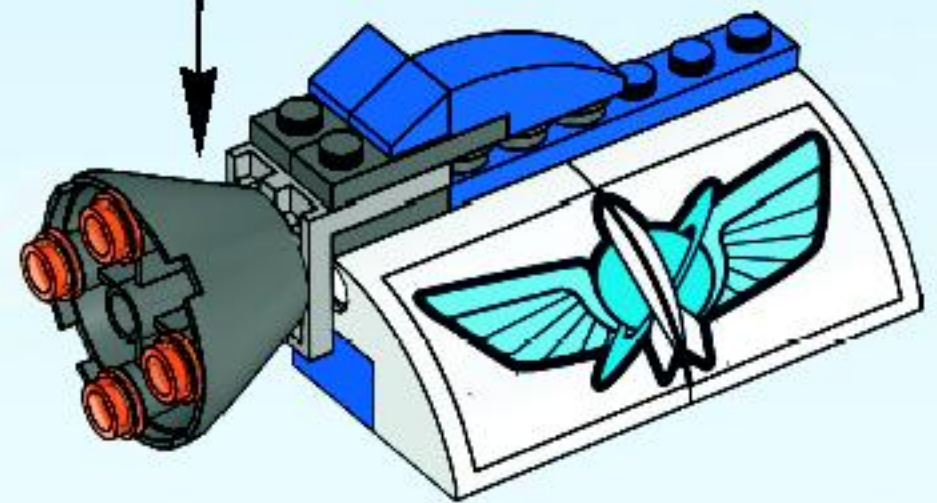
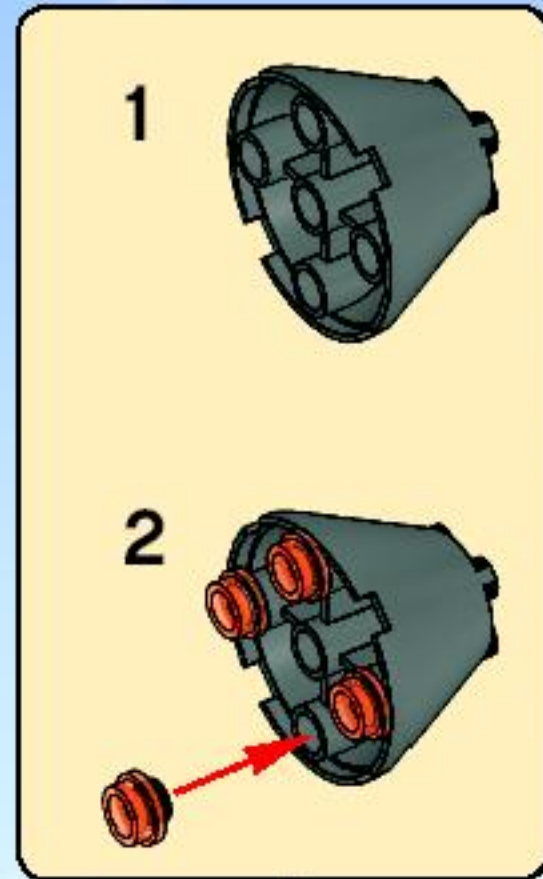

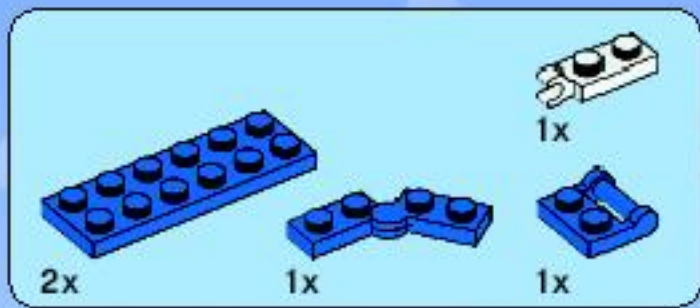

12

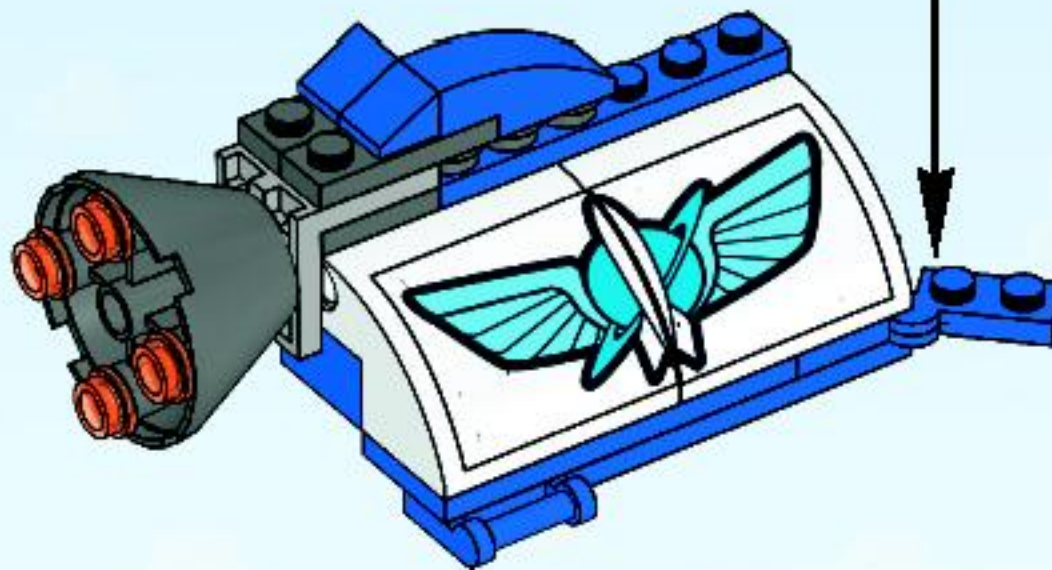
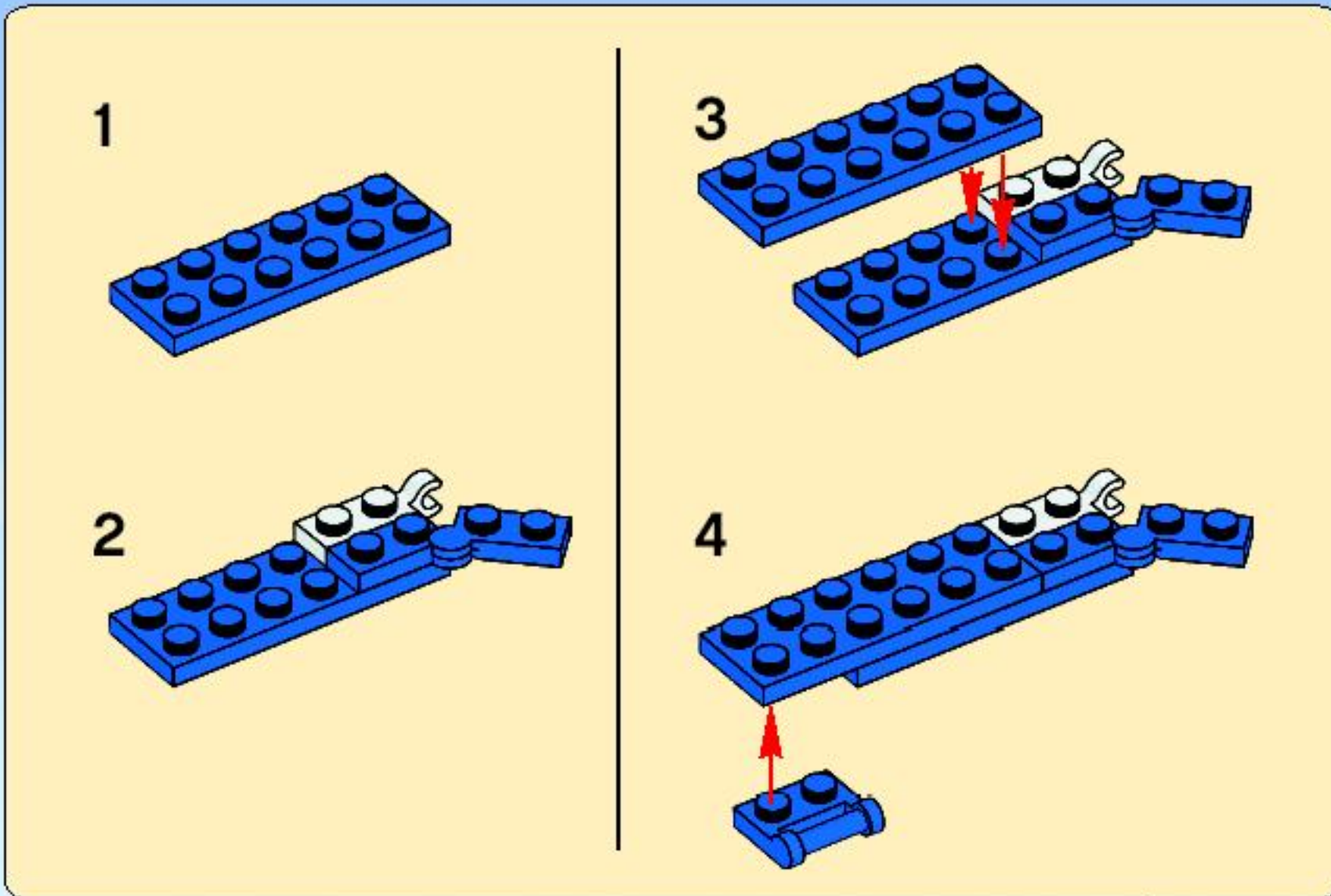



26

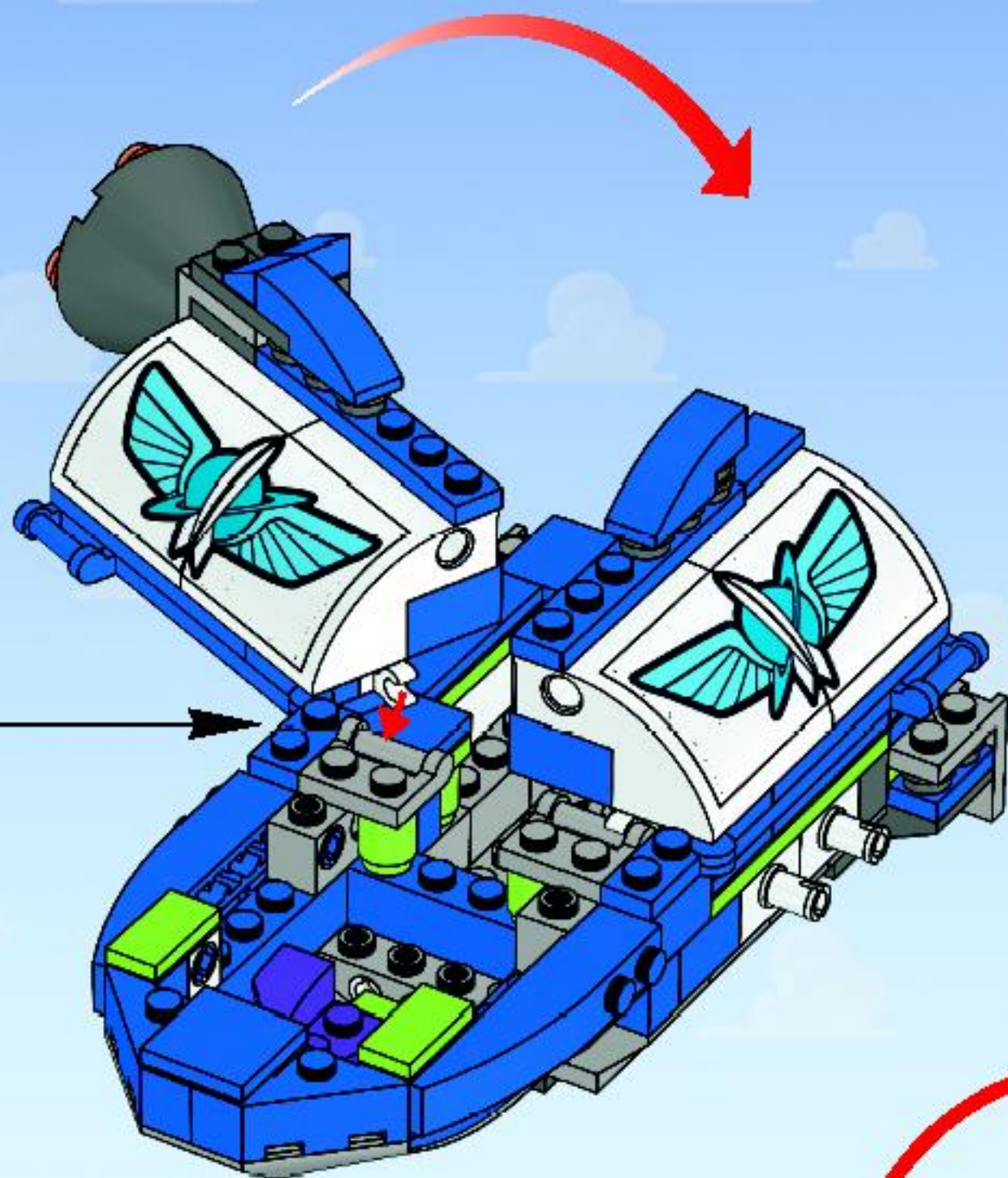

click!

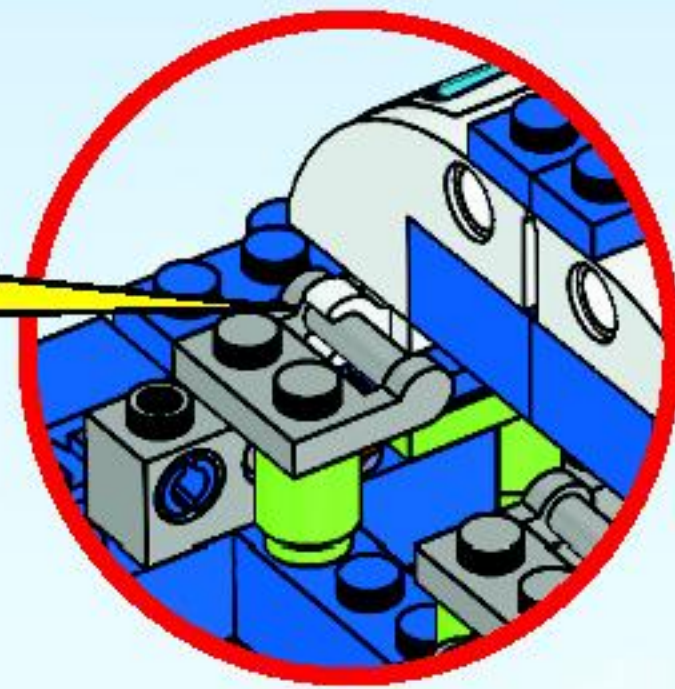



2x



2x

# 27

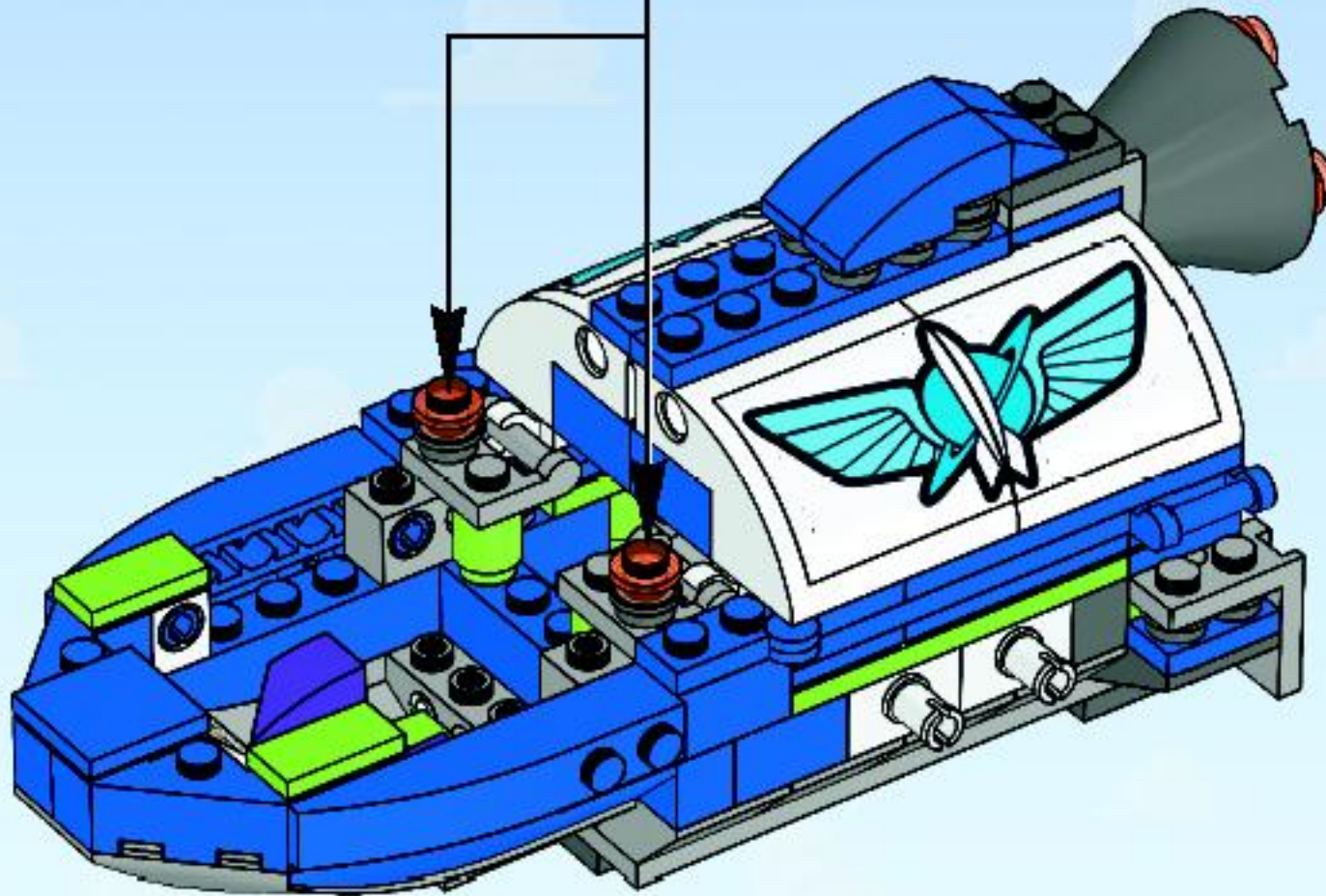



28

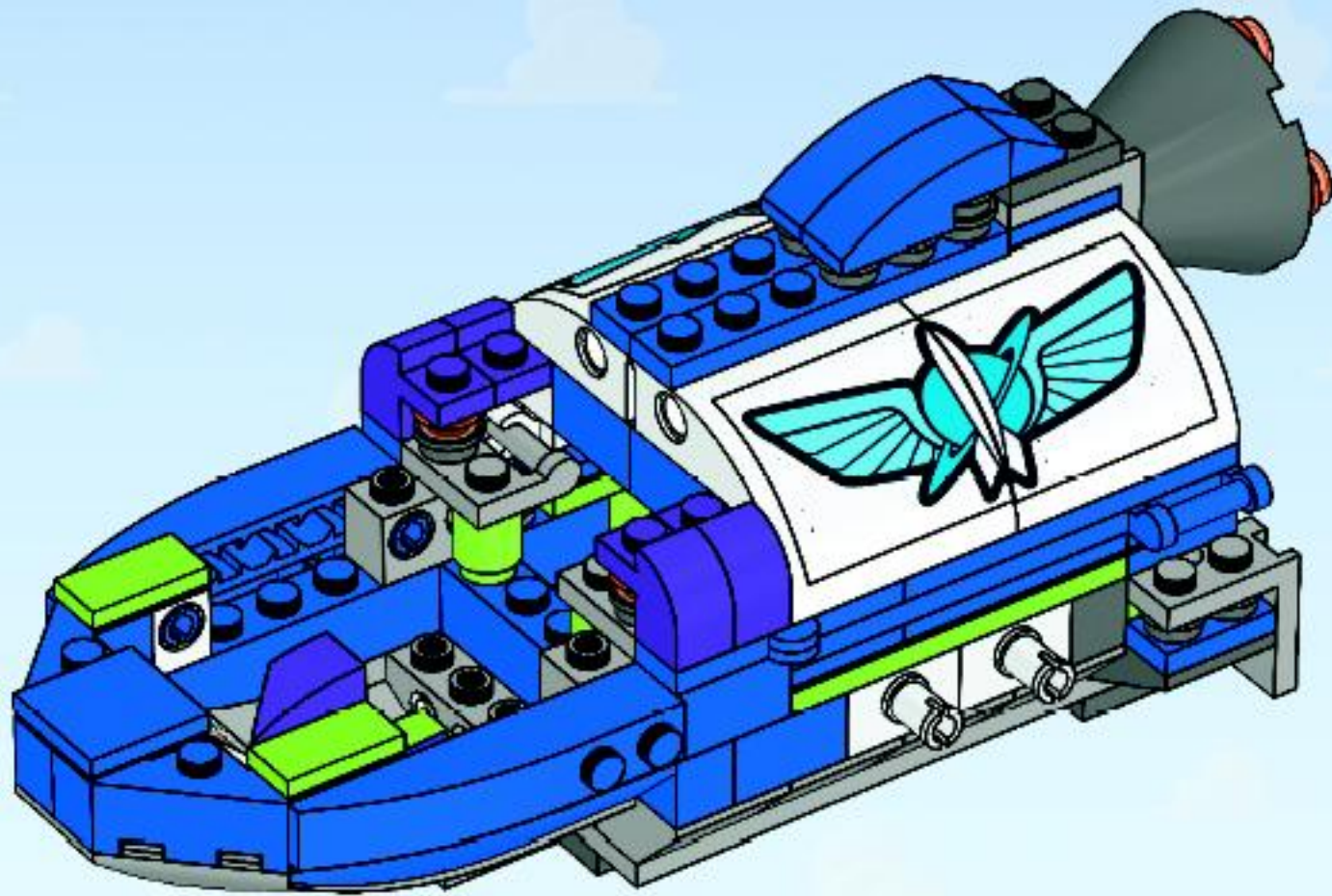

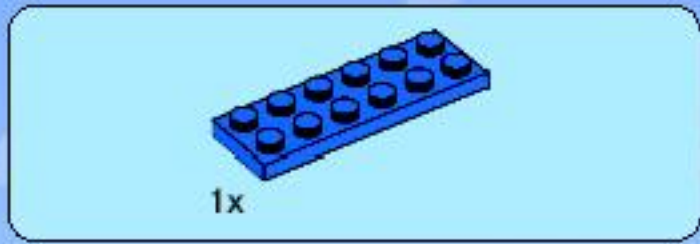

29

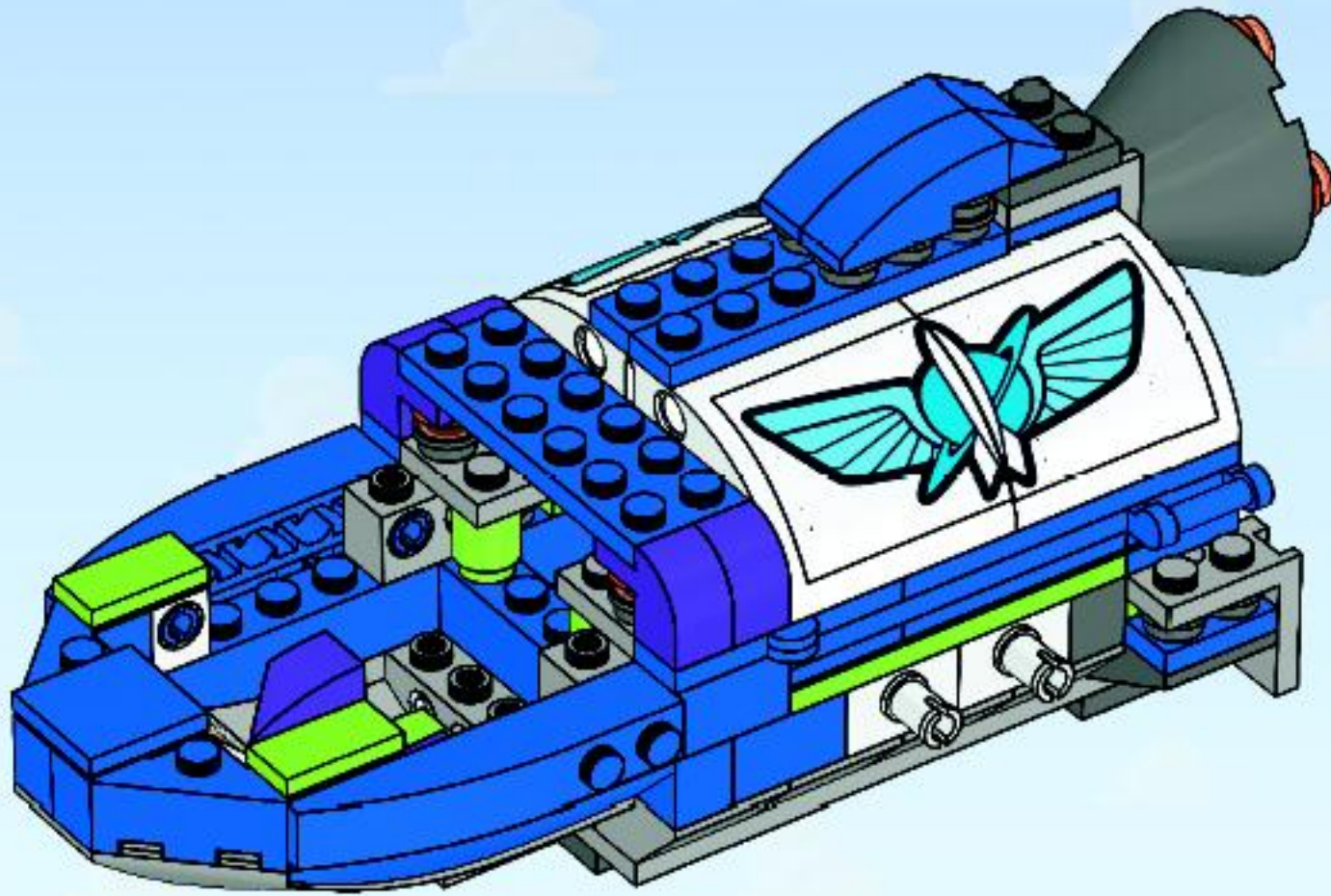



3x

# 30

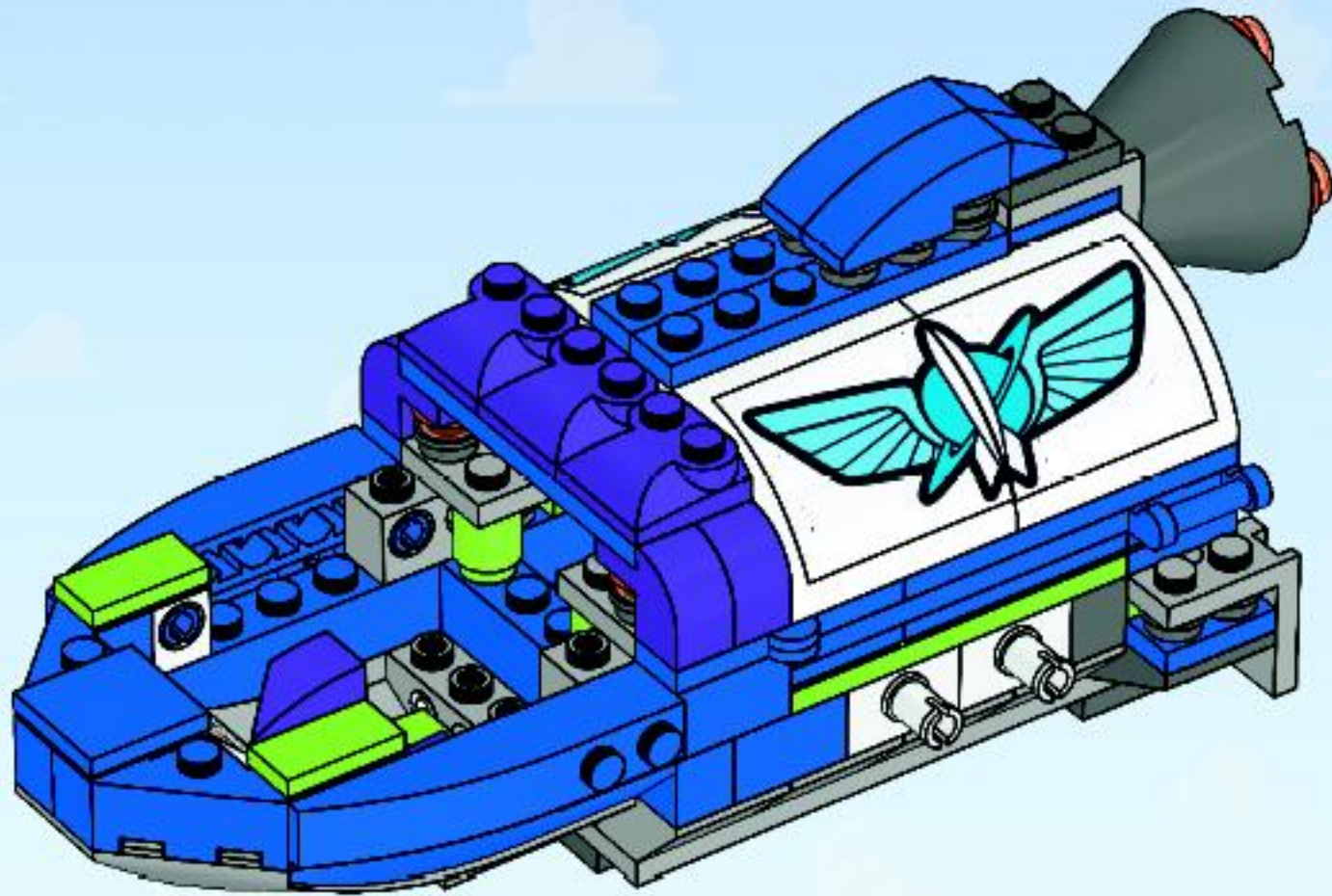



1x

# 31

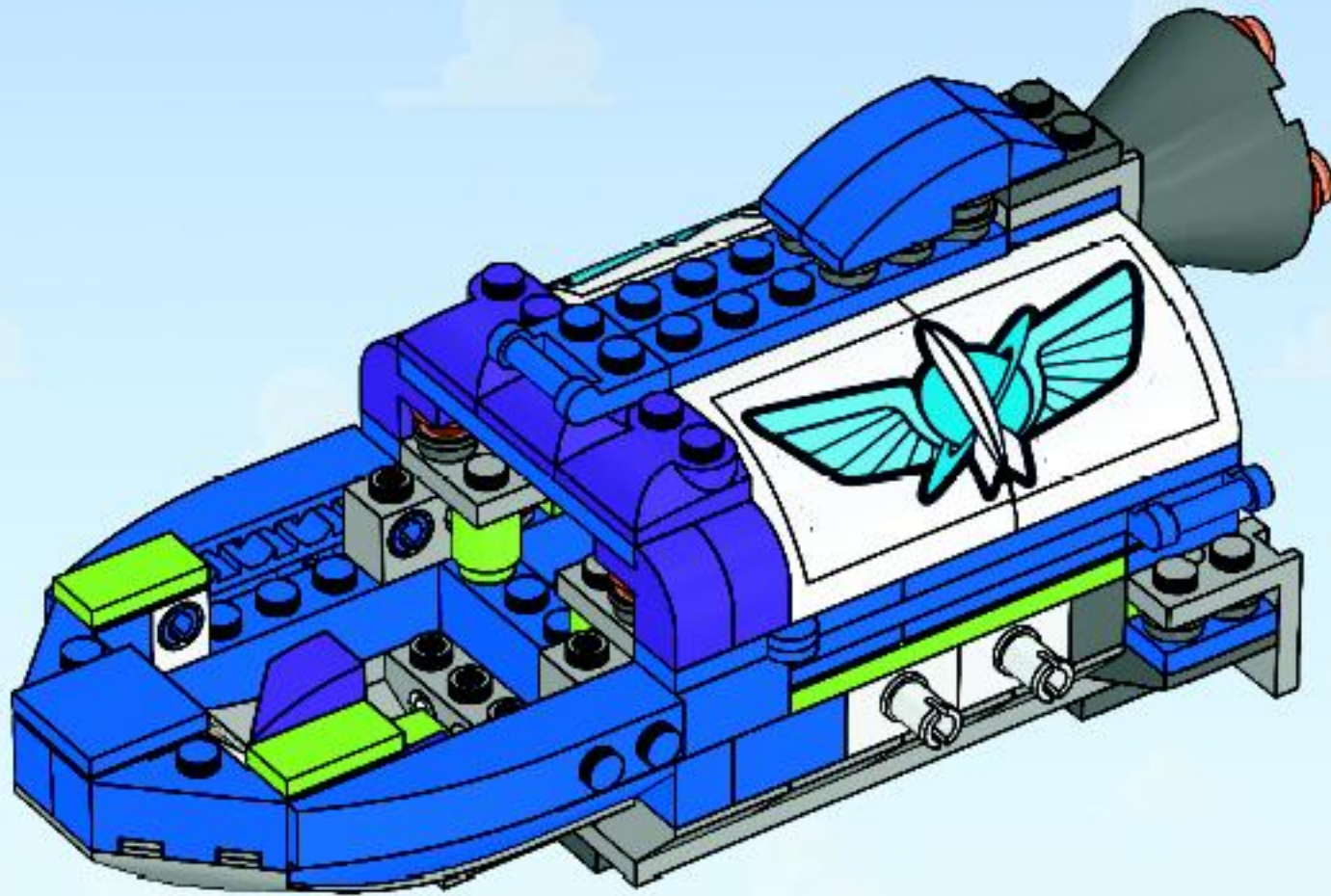

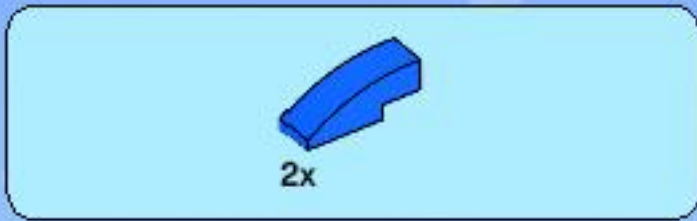

32

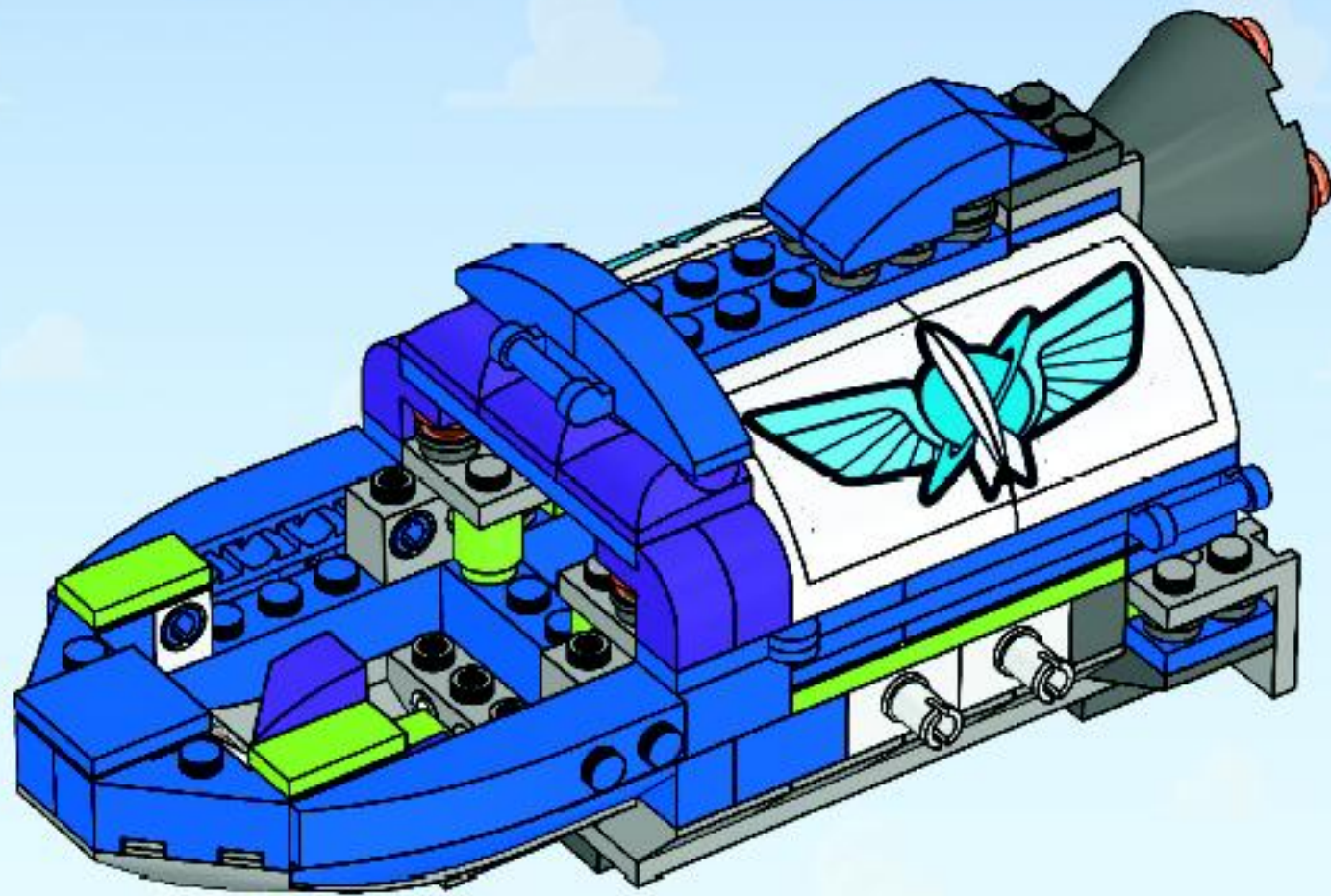

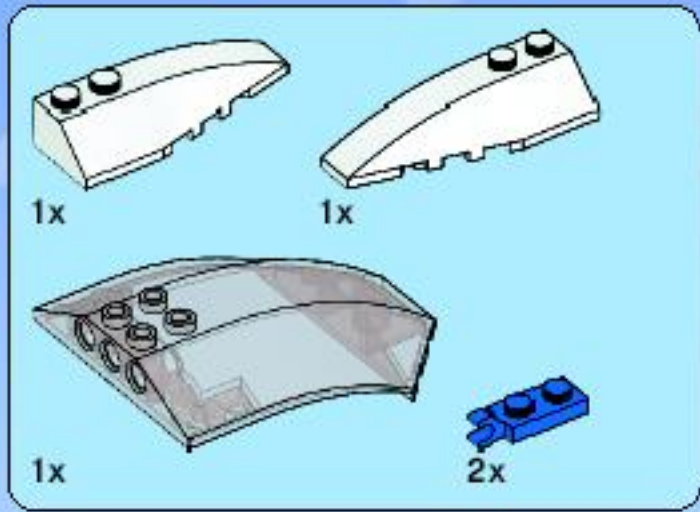

33

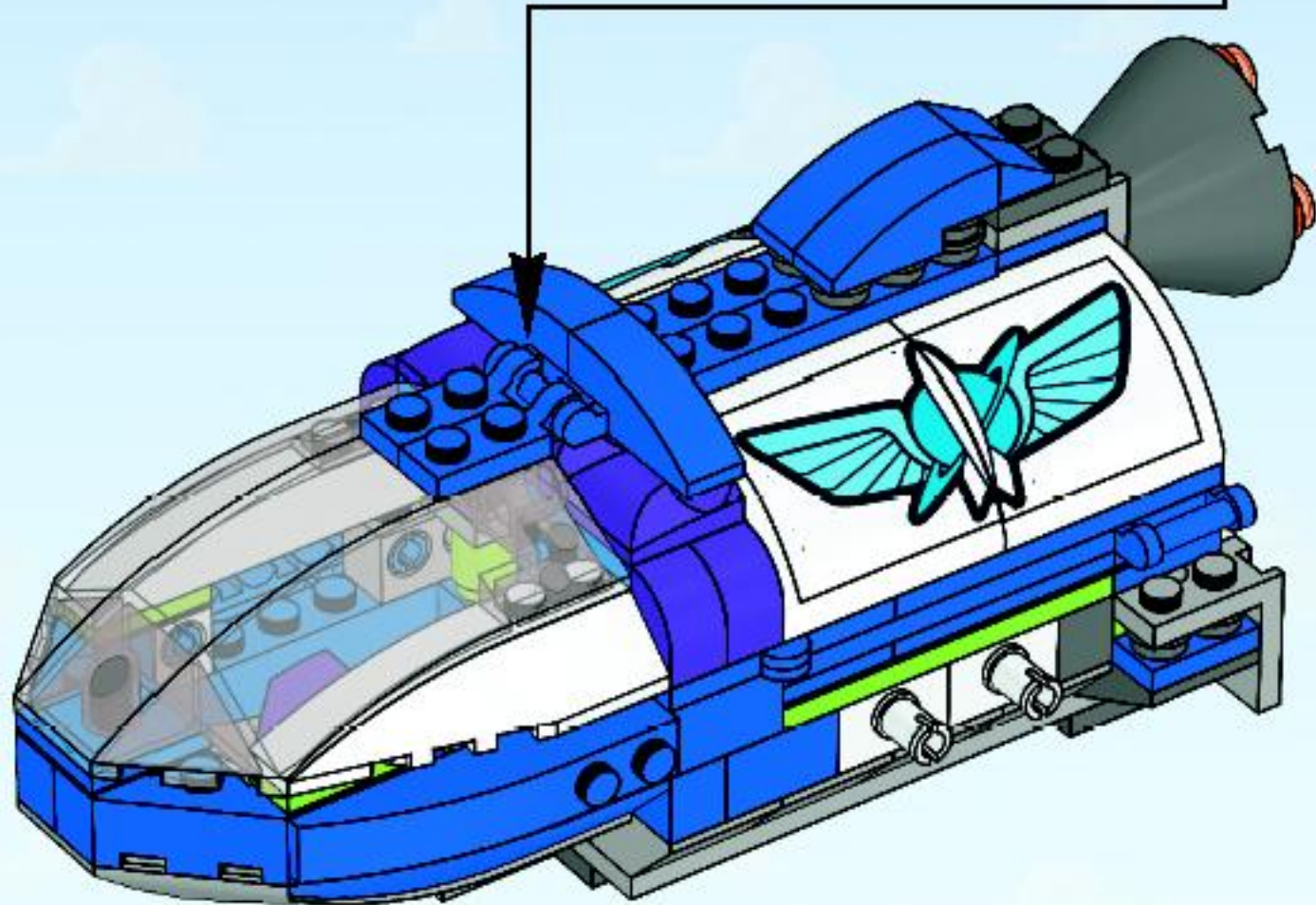
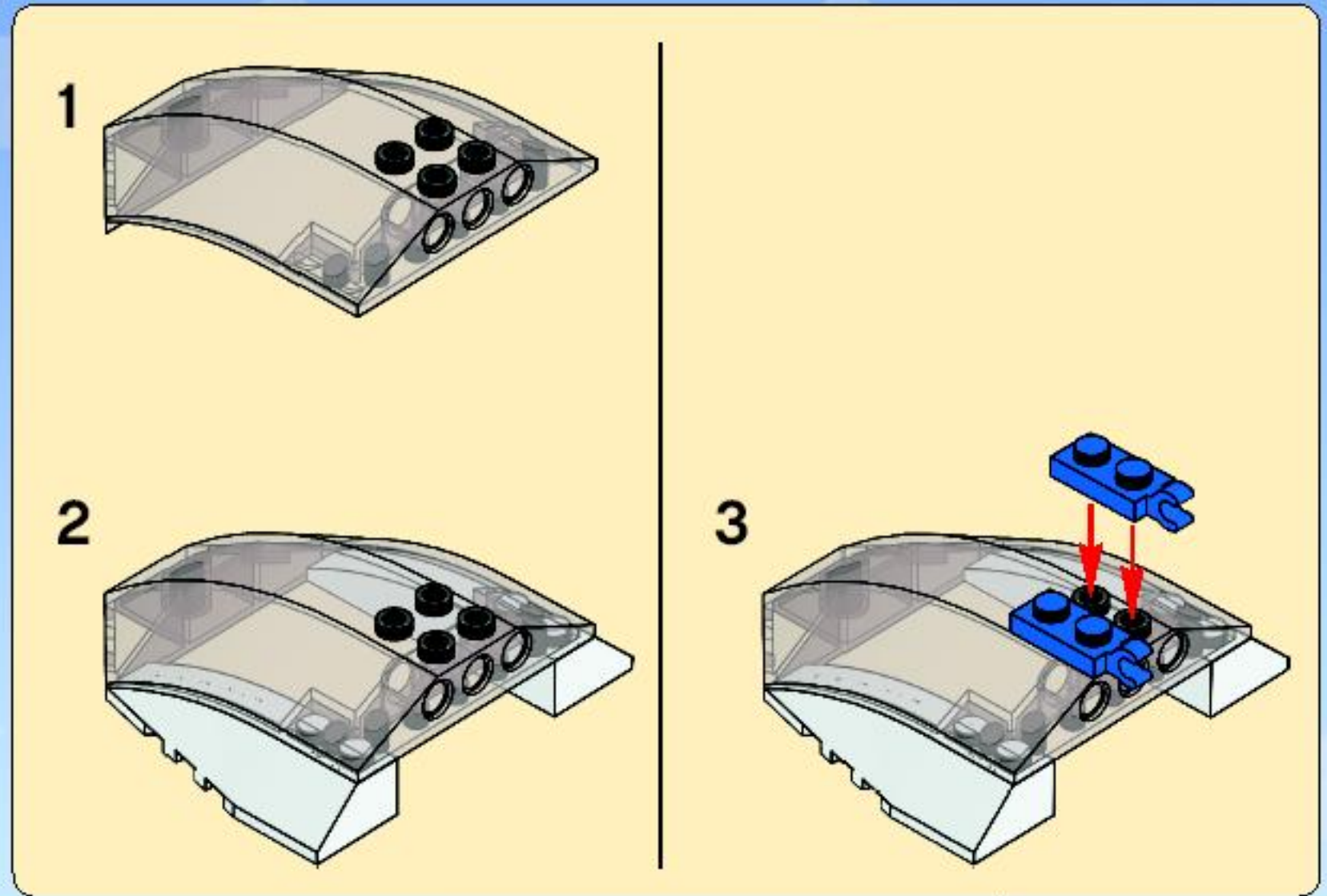



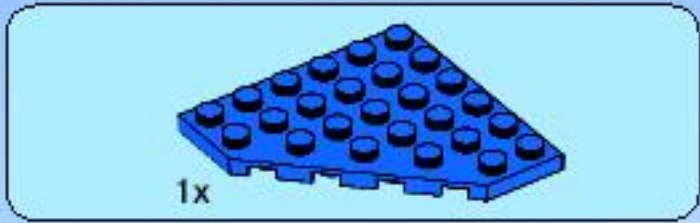

1

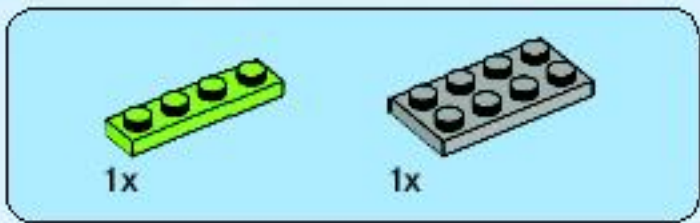
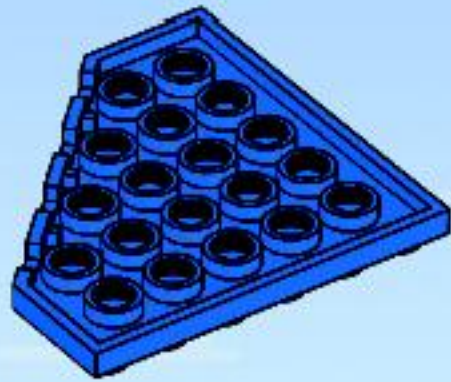

2

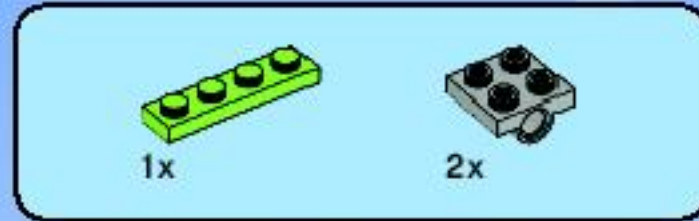
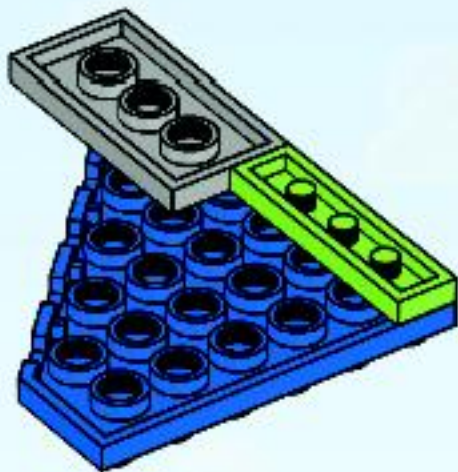

3

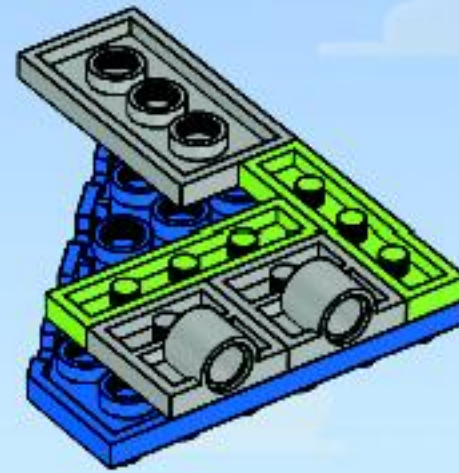

4

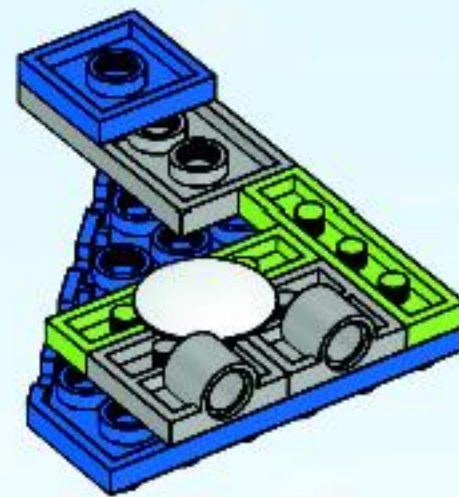



5

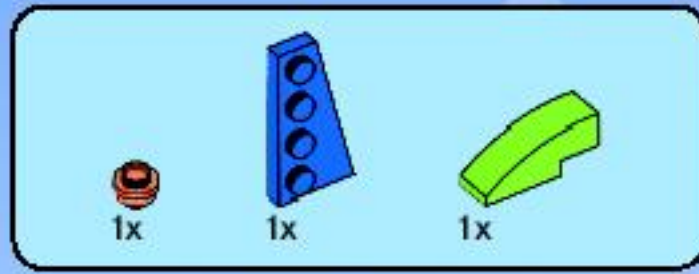
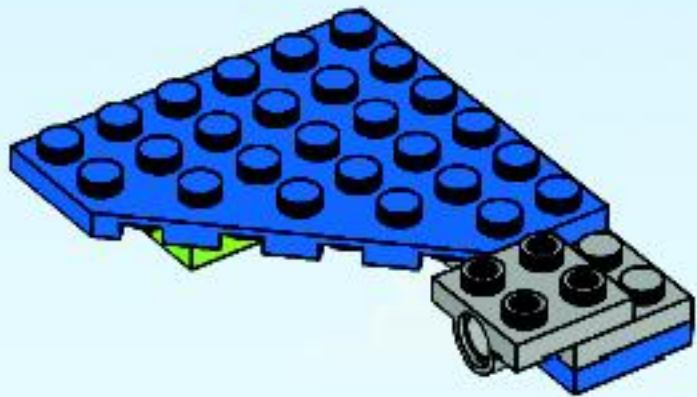

6

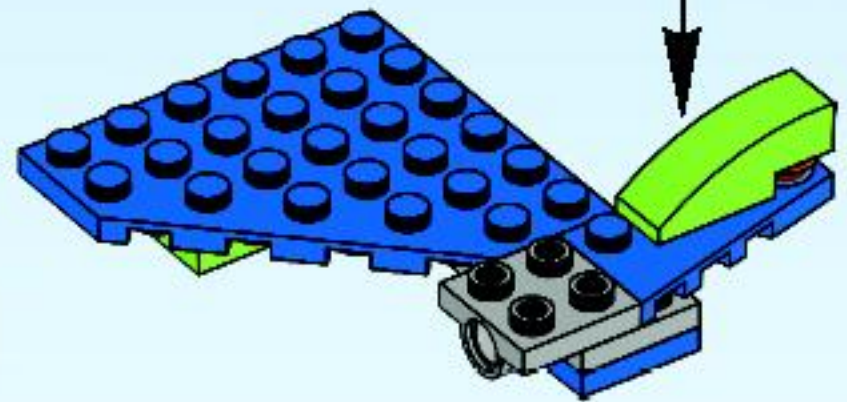
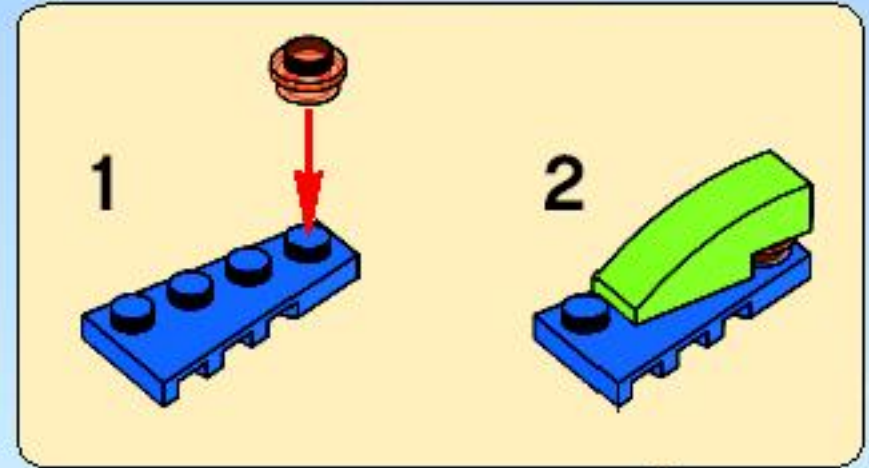

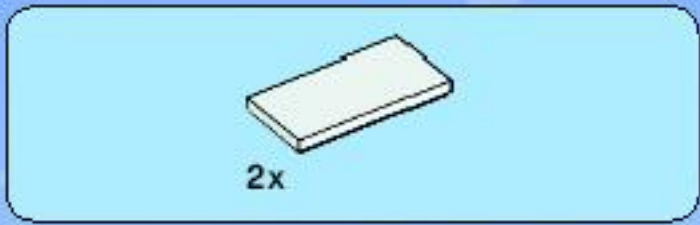

7

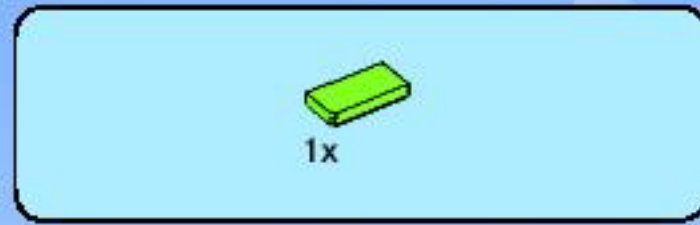
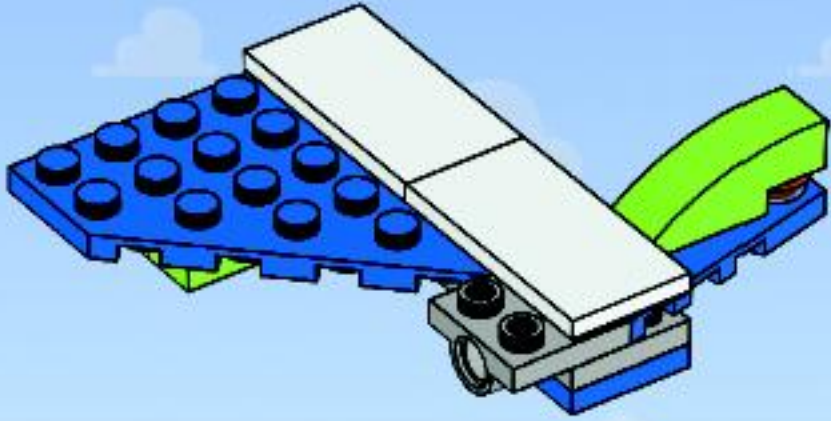

8

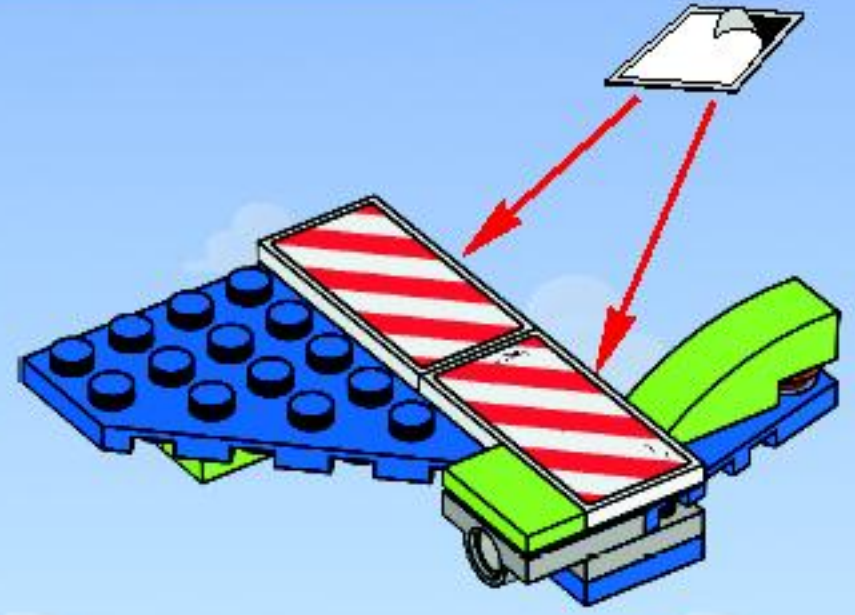

34

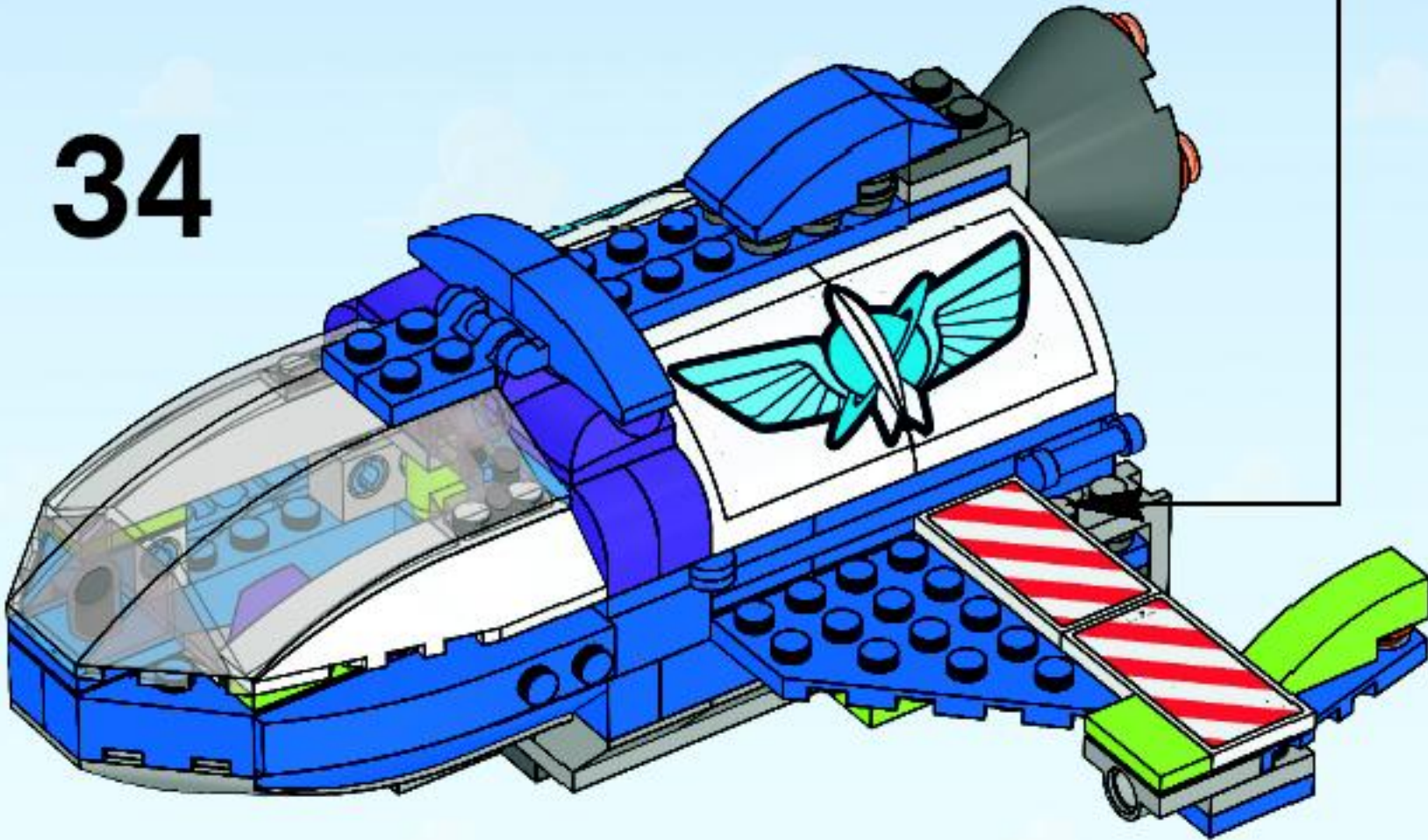

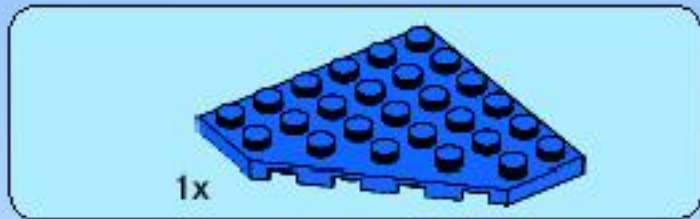

1

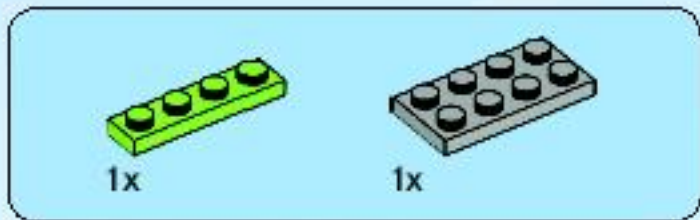
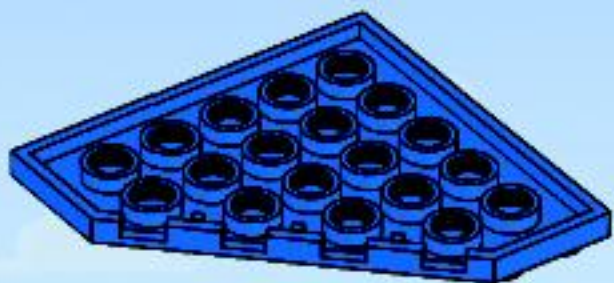

2

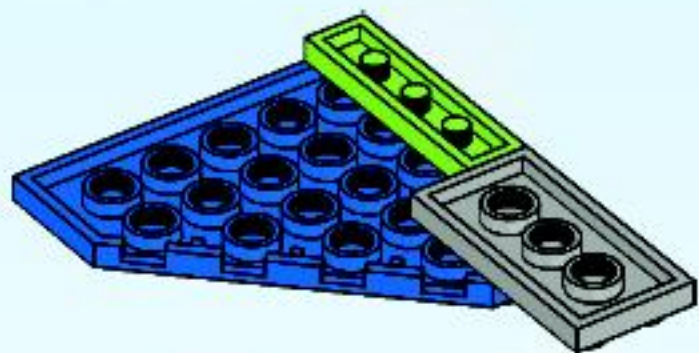

3

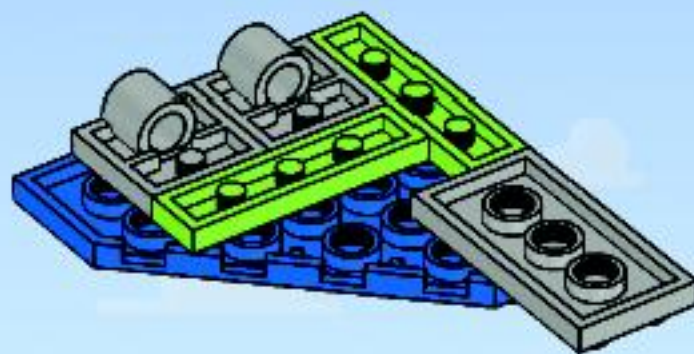

4

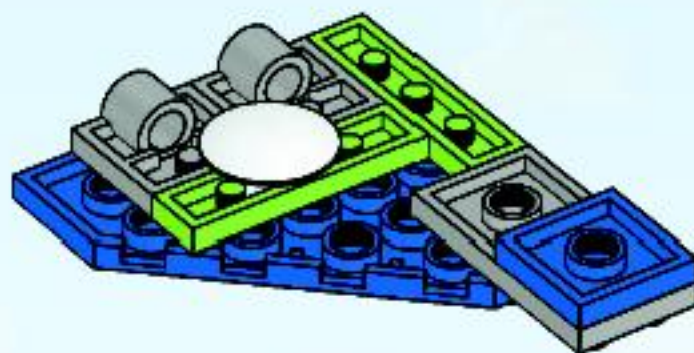



5

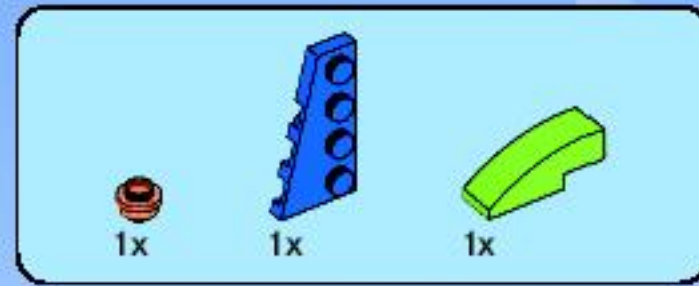
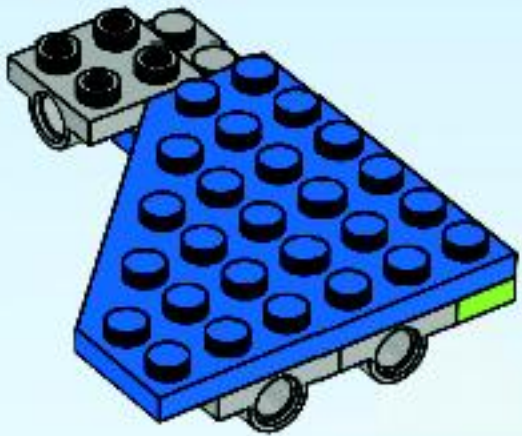

6

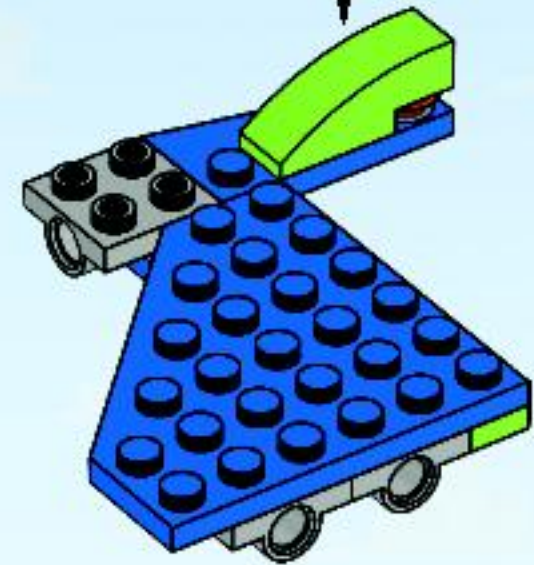
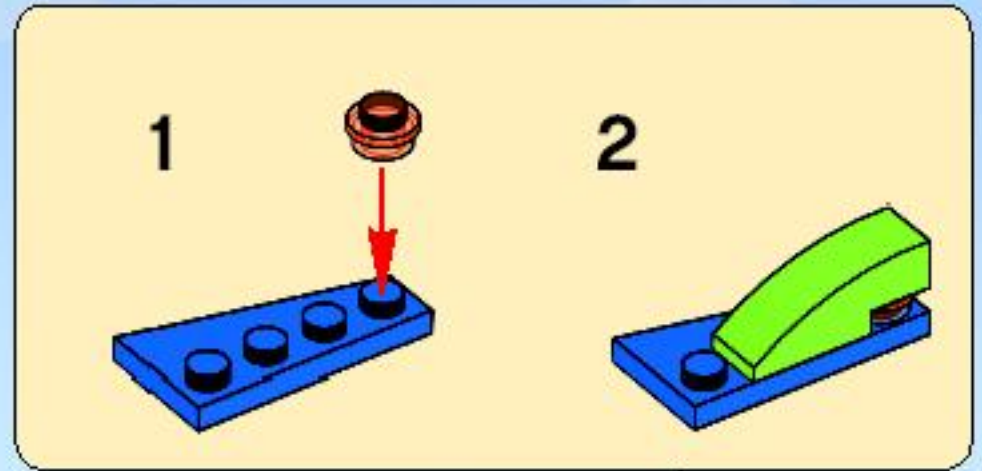

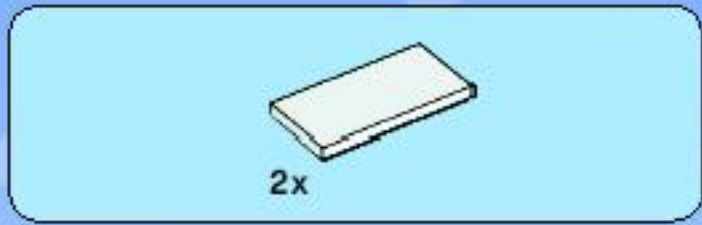

7

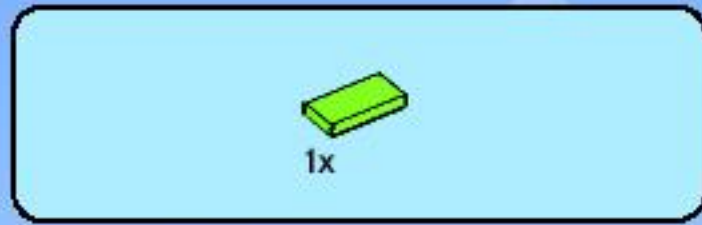
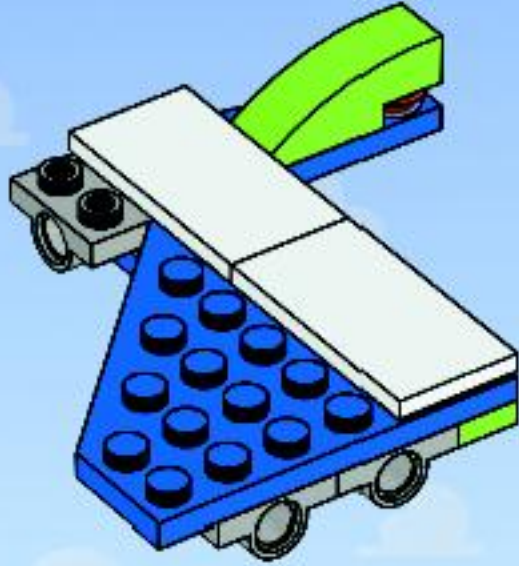

8



35

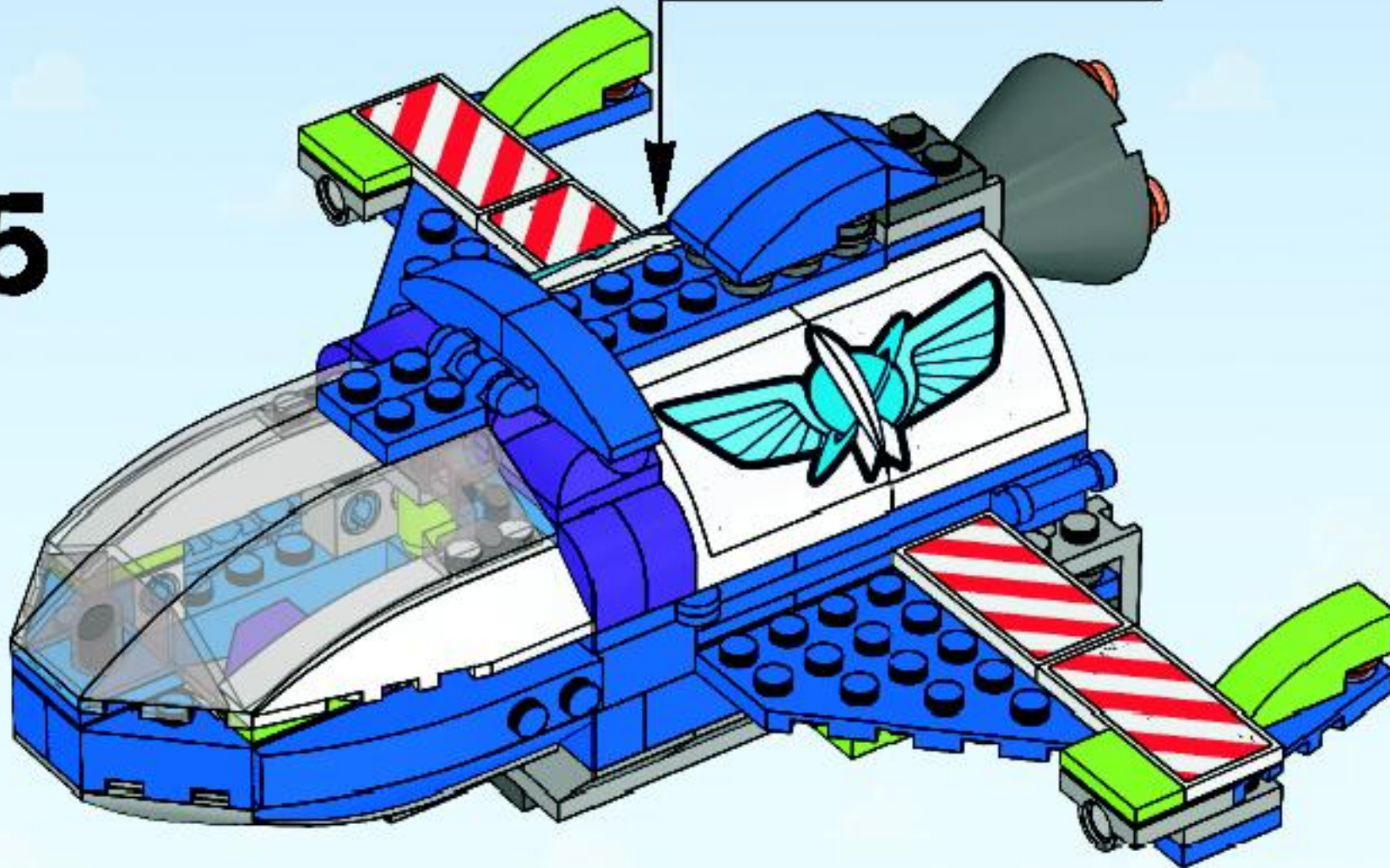

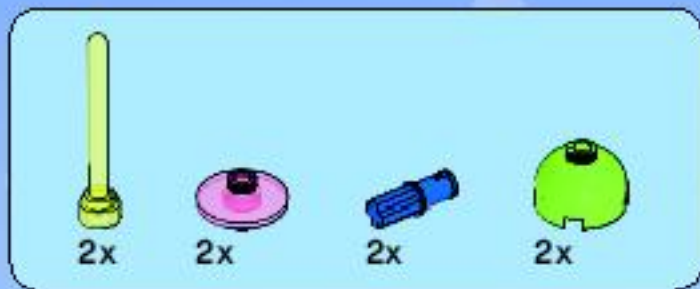

36

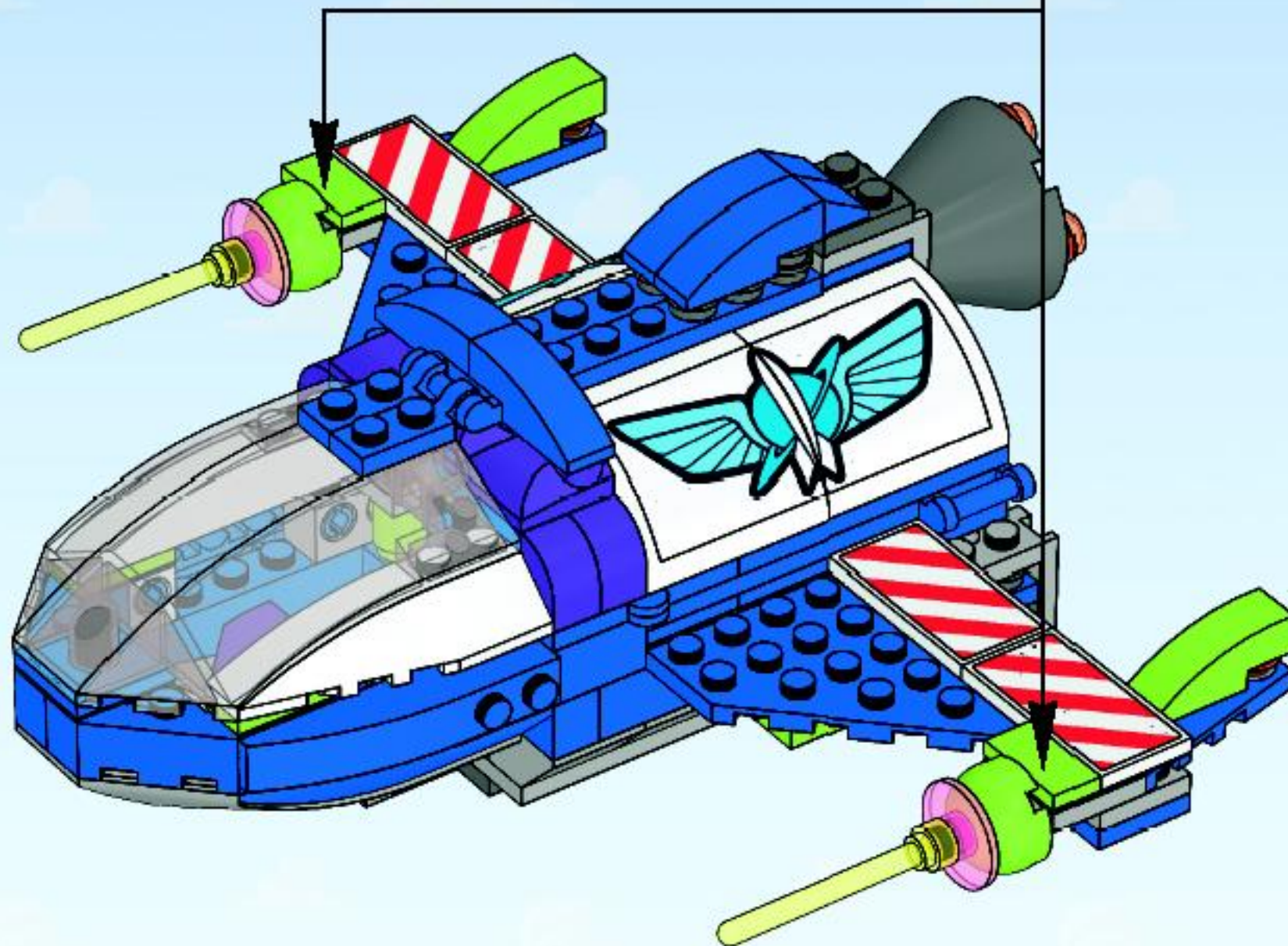
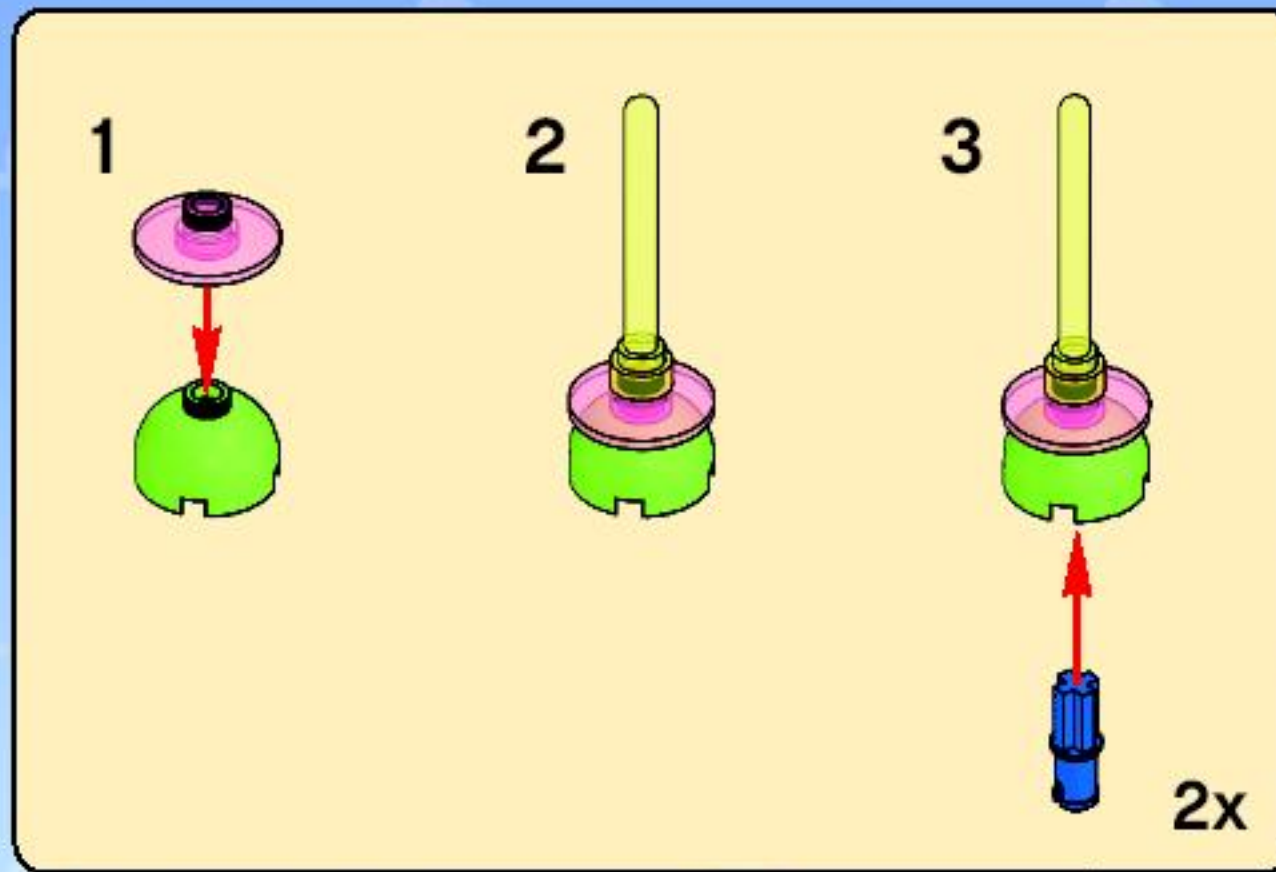



37

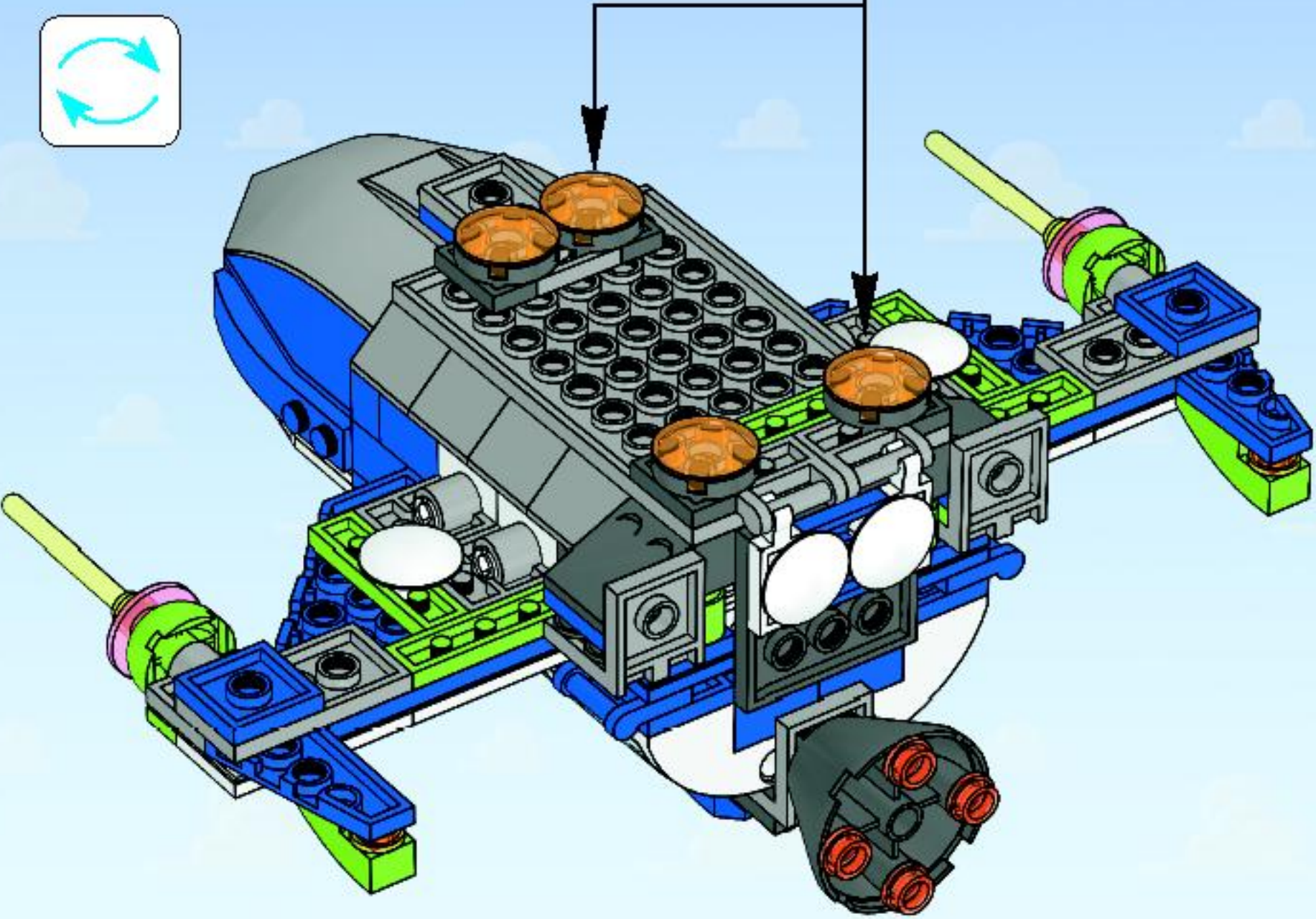
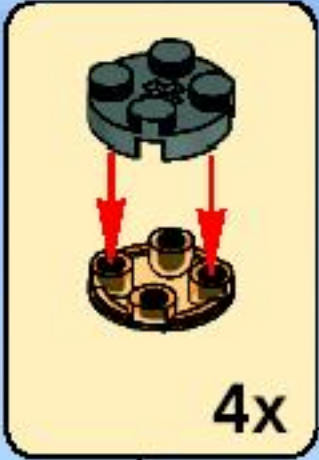



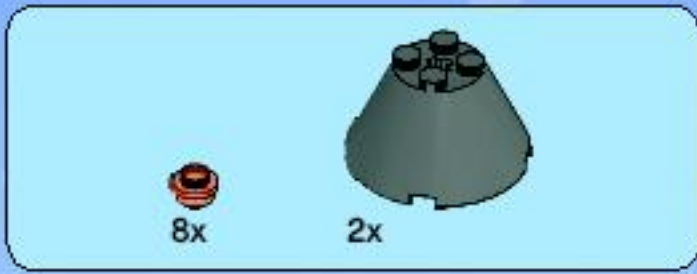

38

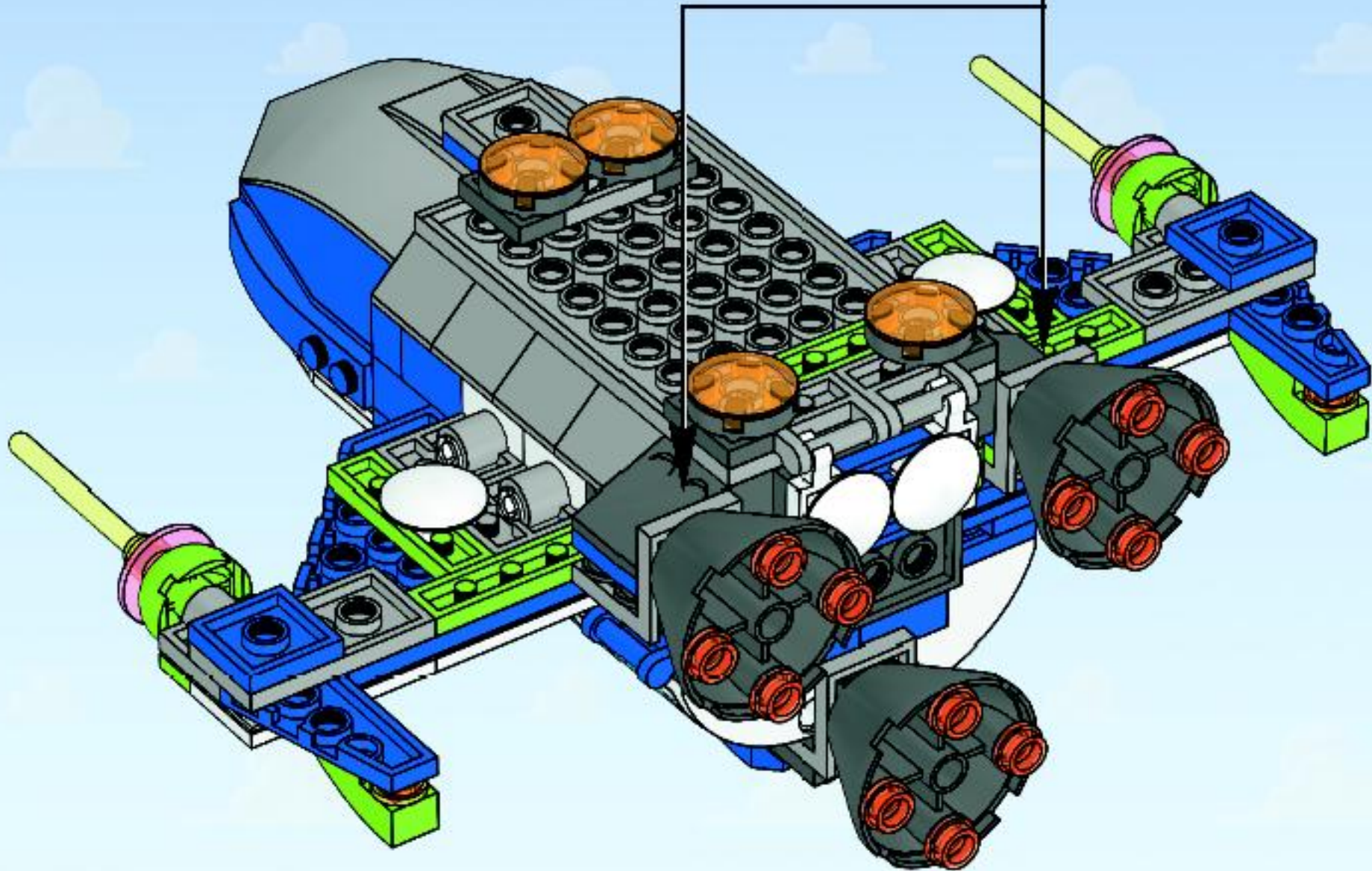
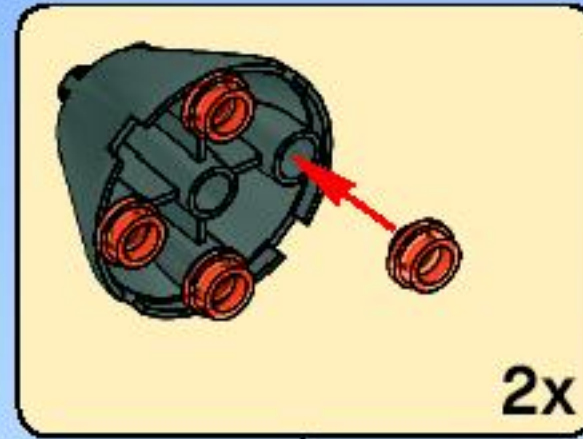

39

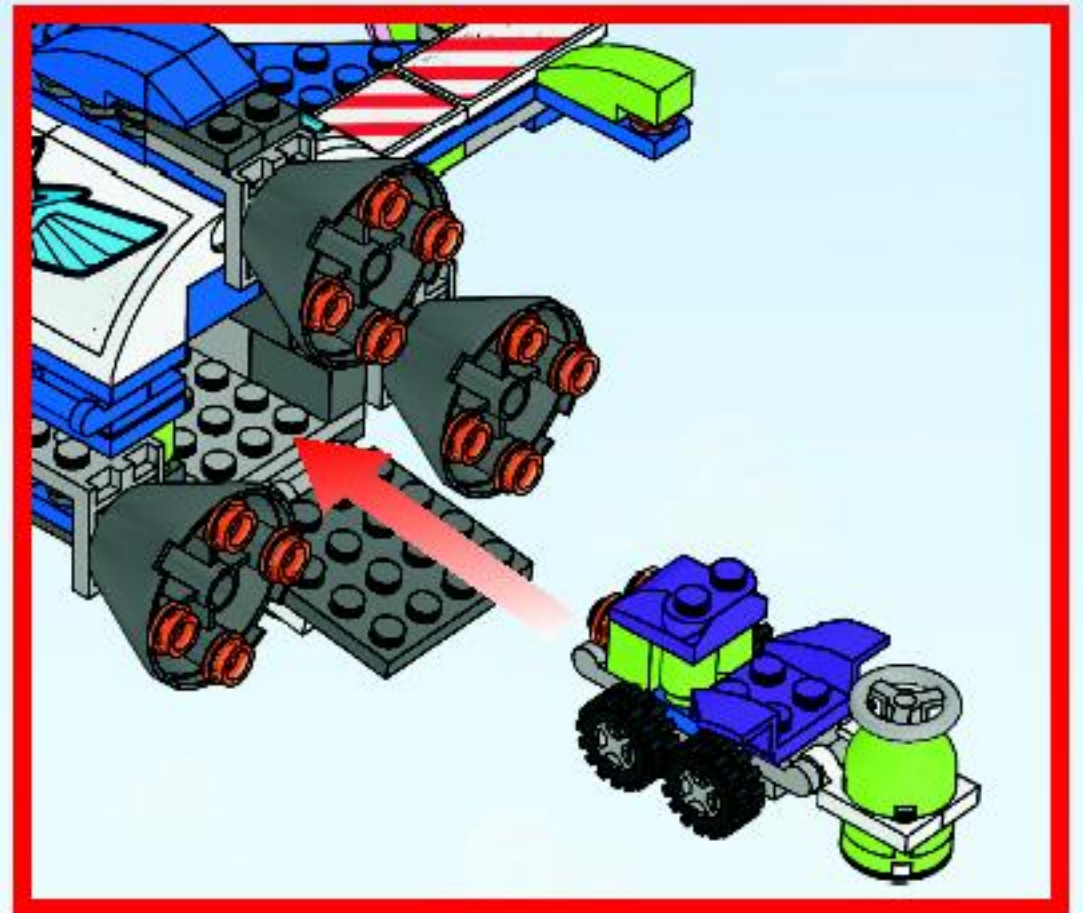
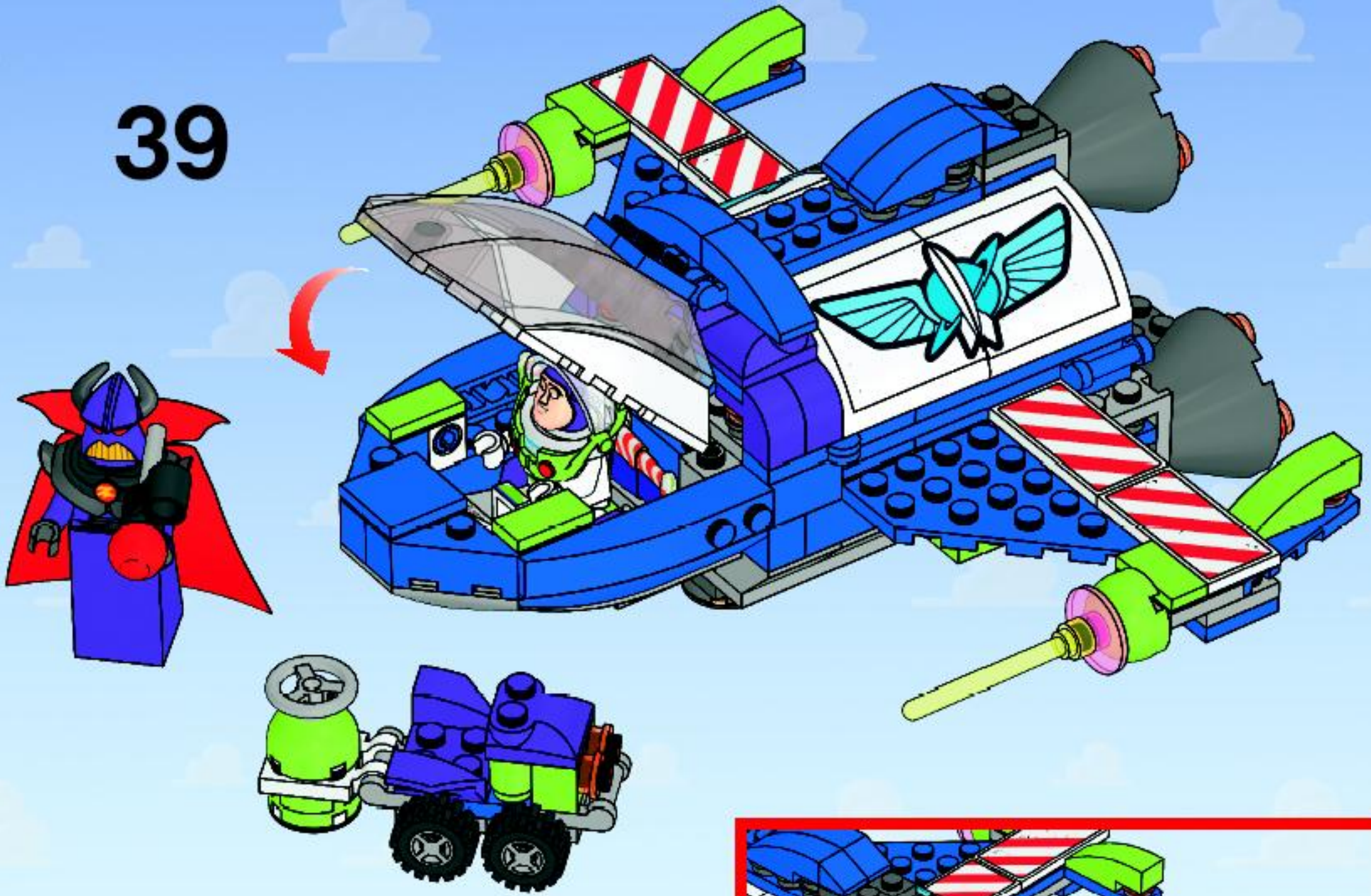





**7590**



**7595**

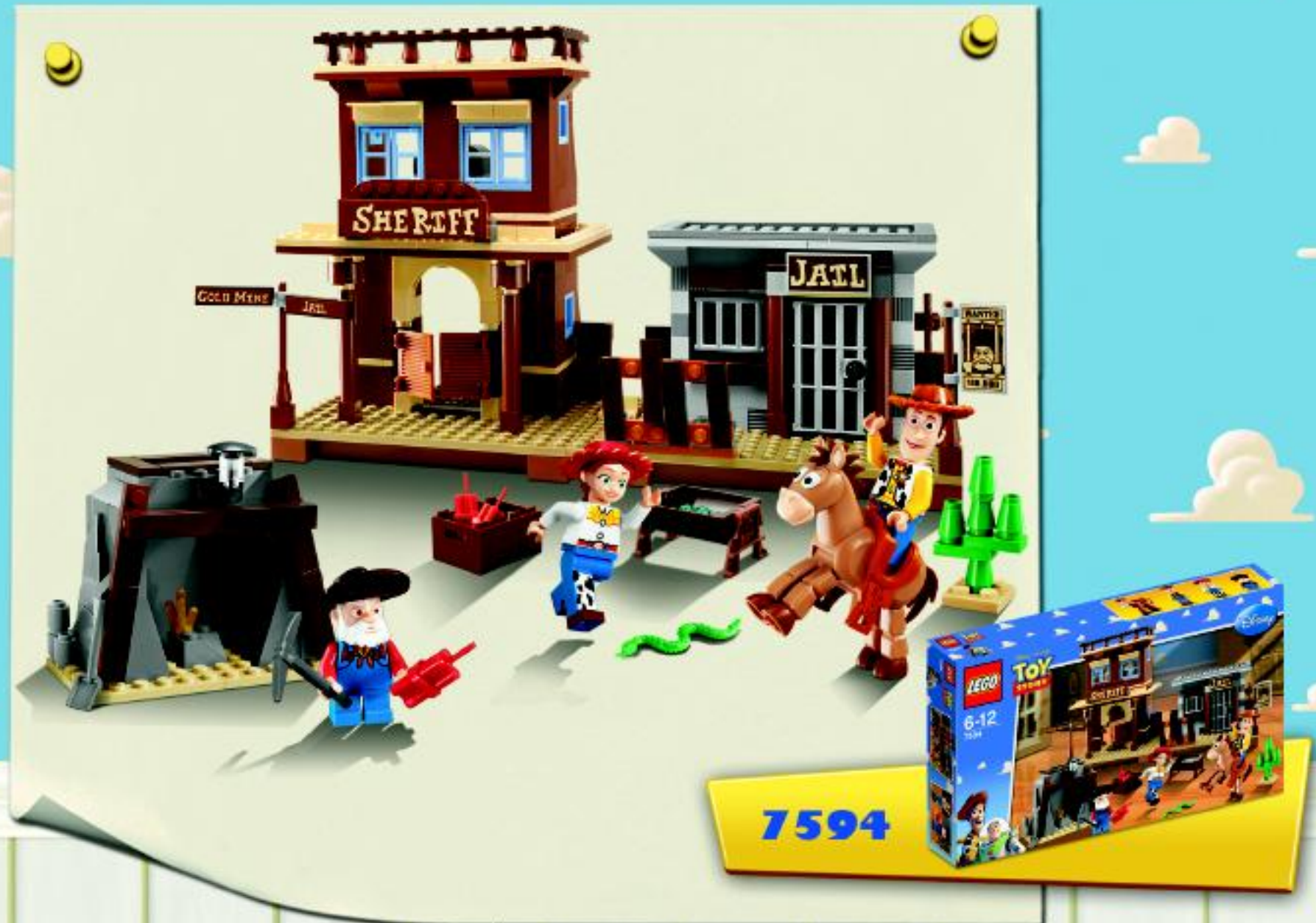

**7594**



**7591**



**7592**



**Customer Service**  
**Kundenservice**  
**Service Consommateurs**  
**Servicio Al Consumidor**  
[www.lego.com/service](http://www.lego.com/service) or dial  
  
 00800 5346 5555 :  
 1-800-422-5346 :

FREE! GRATIS! GRATUIT!



club  
MAGAZINE™

www.LEGOclub.com



00800 5346 5555\*        

  1-866-534-6258 • 1-877-518-5346

US & Canada only

Canada seulement



VISIT THE WORLD'S  
BIGGEST LEGO® SHOP!

[www.LEGOshop.com](http://www.LEGOshop.com)

\* FreePhone. Mobile charges may apply. \* Numéro sans Frais. Des Frais peuvent s'appliquer avec les téléphones cellulaires. \* Gebührenfrei. Kosten für Anrufe aus Mobilfunknetzen können anfallen.  
\* Gratis telefonnummer van Postcode.nl. \* Deber être gratis número, sólo de Ringier Pro Postcode.nl. \* Det är gratis, när du ringer från en Post telefon.



# WIN!

Go to [www.nielsen.com/LEGO](http://www.nielsen.com/LEGO) to fill out a survey for a chance to win a cool LEGO® Product.  
No purchase necessary.  
Open to all residents where not prohibited.

 [www.LEGO.com](http://www.LEGO.com)



## [www.nielsen.com/LEGO](http://www.nielsen.com/LEGO)

### GEWINNE! WIN!

Nimm an der Umfrage auf [www.nielsen.com/LEGO](http://www.nielsen.com/LEGO) teil und hab die Chance ein cooles LEGO® Produkt zu gewinnen!

Die Teilnahme am Gewinnspiel führt zu keinerlei Kaufverpflichtungen. Teilnahme in allen nicht ausgeschlossenen Ländern möglich.

Ga naar [www.nielsen.com/LEGO](http://www.nielsen.com/LEGO), vul een enquêteformulier in en maak kans op een cool LEGO® product.

Geen aankoopverplichting. Iedereen mag deelnemen, uitgezonderd ingezetenden van landen waar een enquêteverbod geldt.

### GAGNE! 当てよう!

Visite [www.nielsen.com/LEGO](http://www.nielsen.com/LEGO) pour répondre à un questionnaire et avoir une chance de gagner un produit LEGO® très cool!

Aucune obligation d'achat. Ouvert à tous les résidents des pays autorisés.

[www.nielsen.com/LEGO](http://www.nielsen.com/LEGO)にアクセスして、アンケートにご記入ください。当選者にはレゴ製品を差し上げます。

お買い上げの必要はありません。禁止されていない限り、すべての店舗にてご利用いただけます。