



HERO FACTORY

HERO FACTORY

7168





HEROFACTORY.LEGO.COM / CONFIDENTIAL / DUNKANBULK



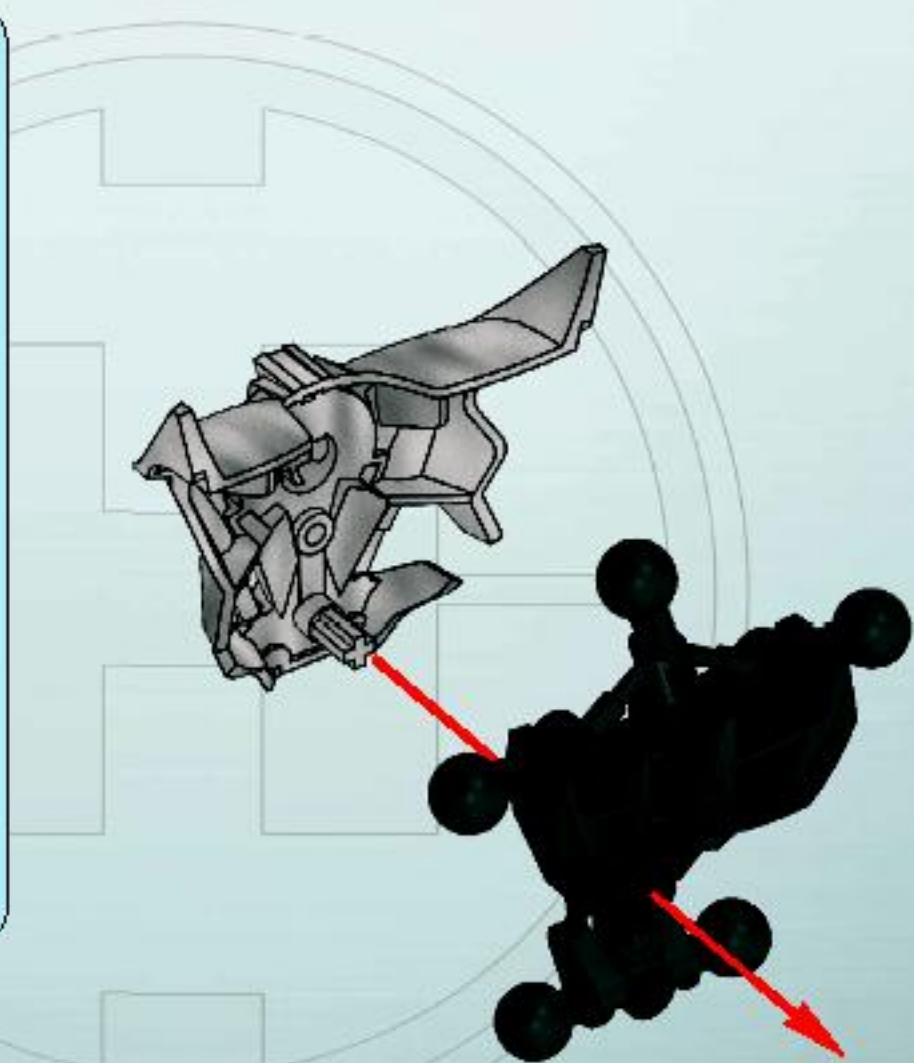
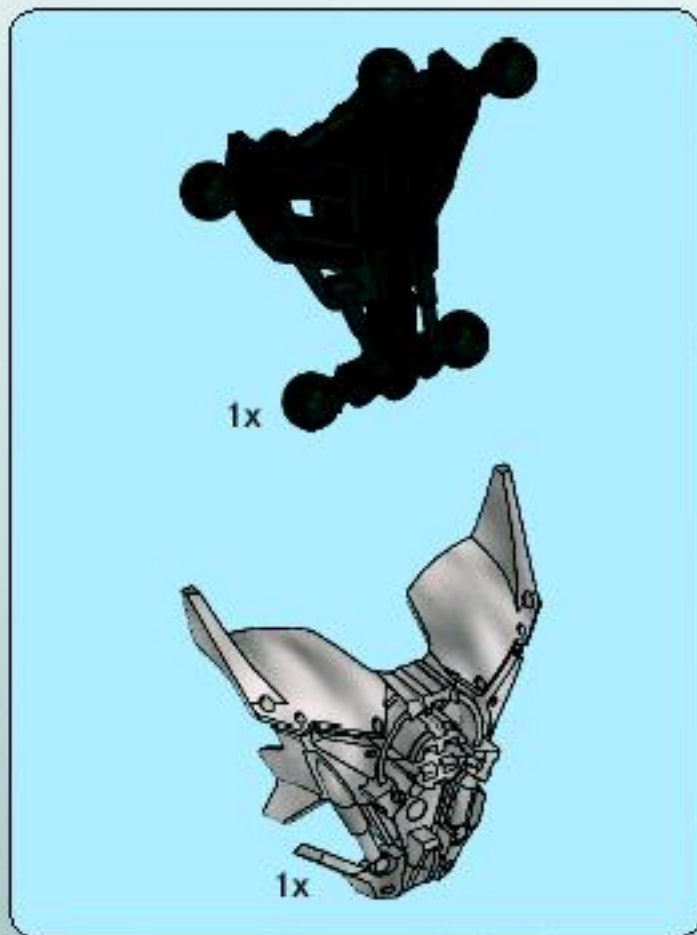

1



1x

2

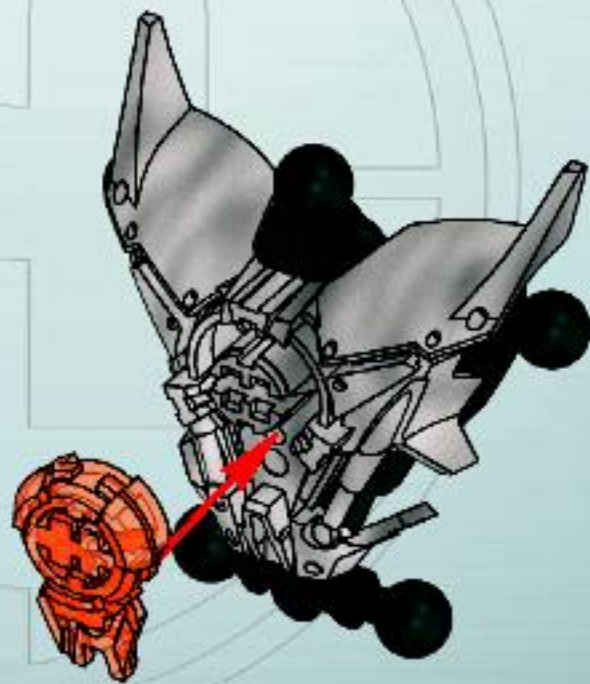

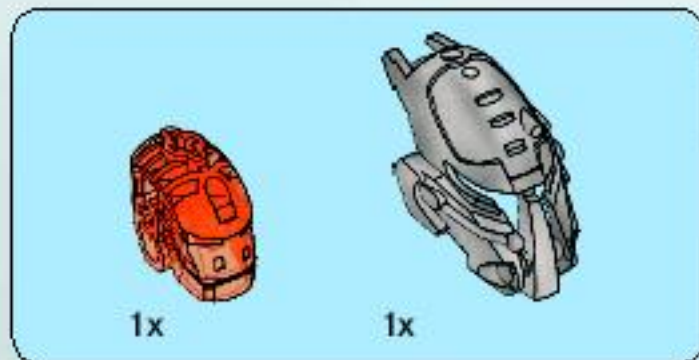

3

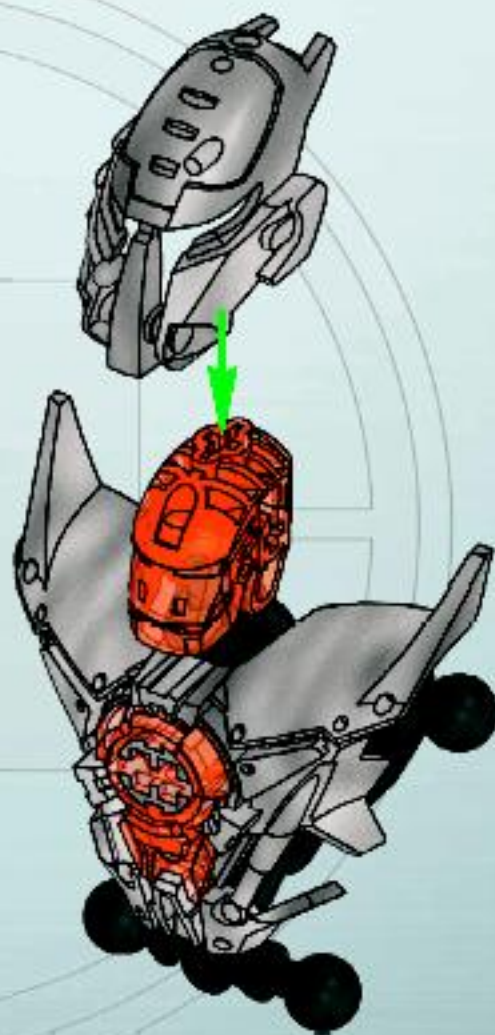

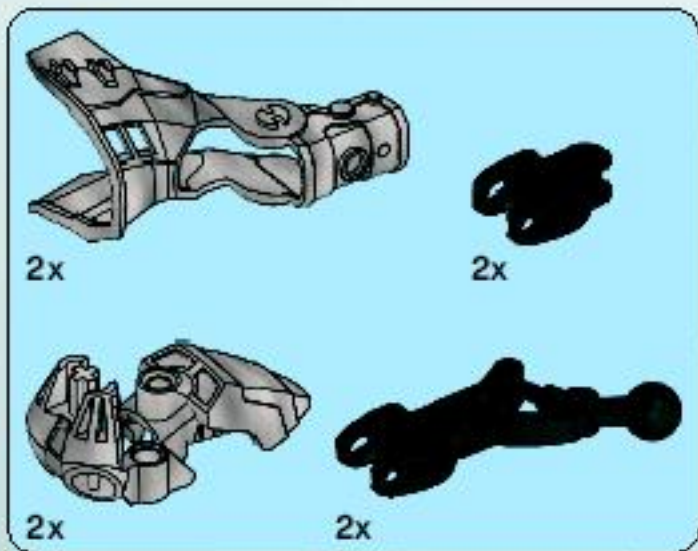

4

1

2

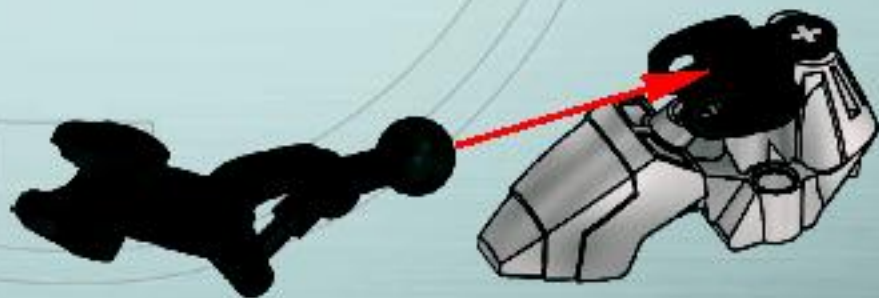
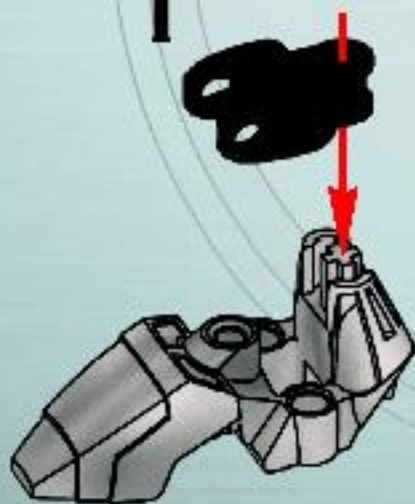

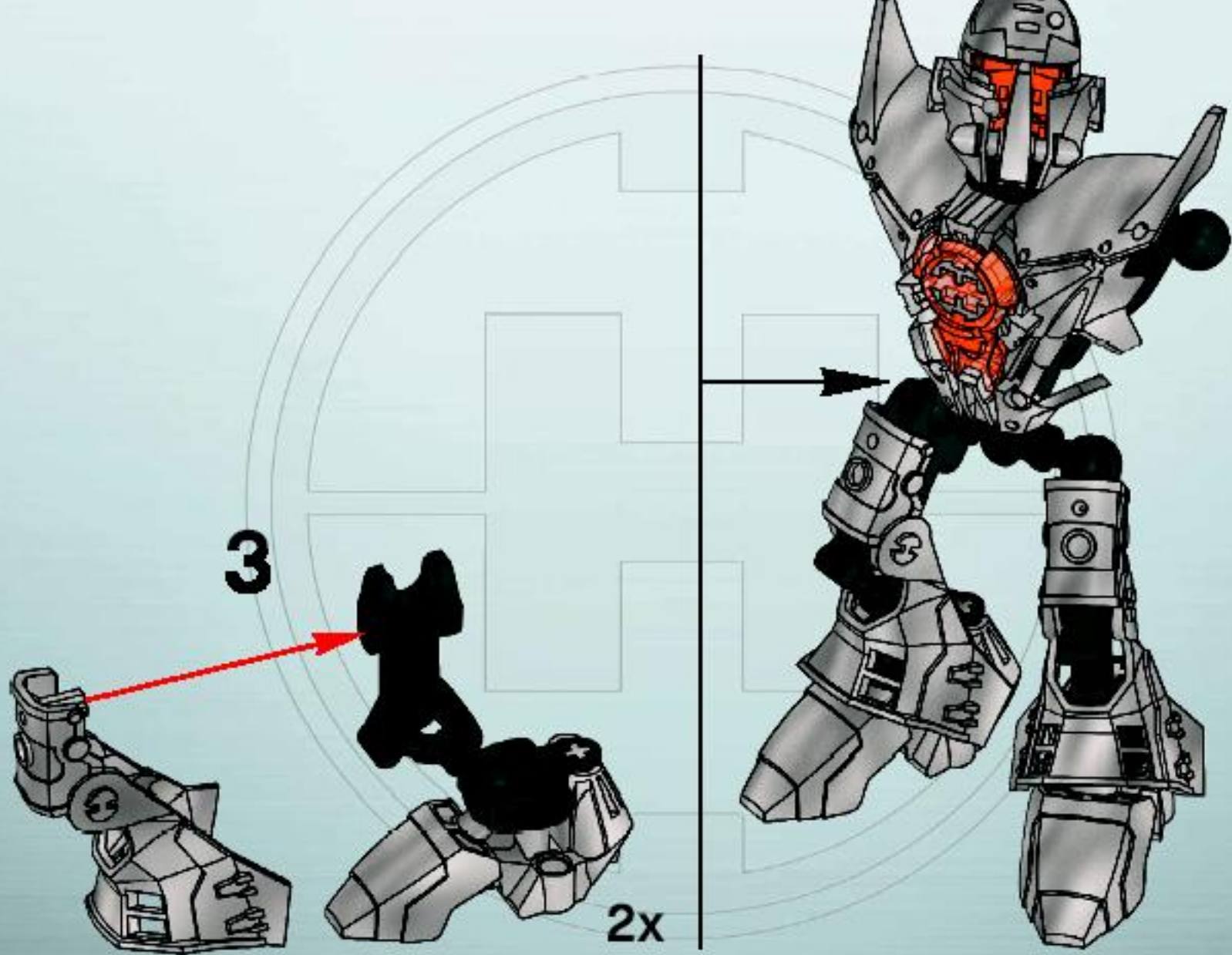



1x



1x

5

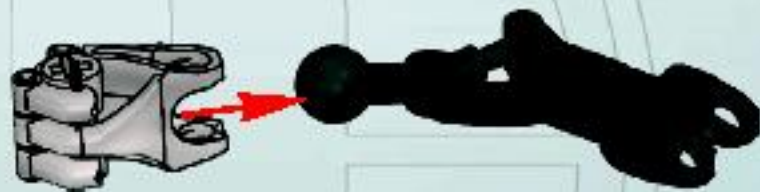

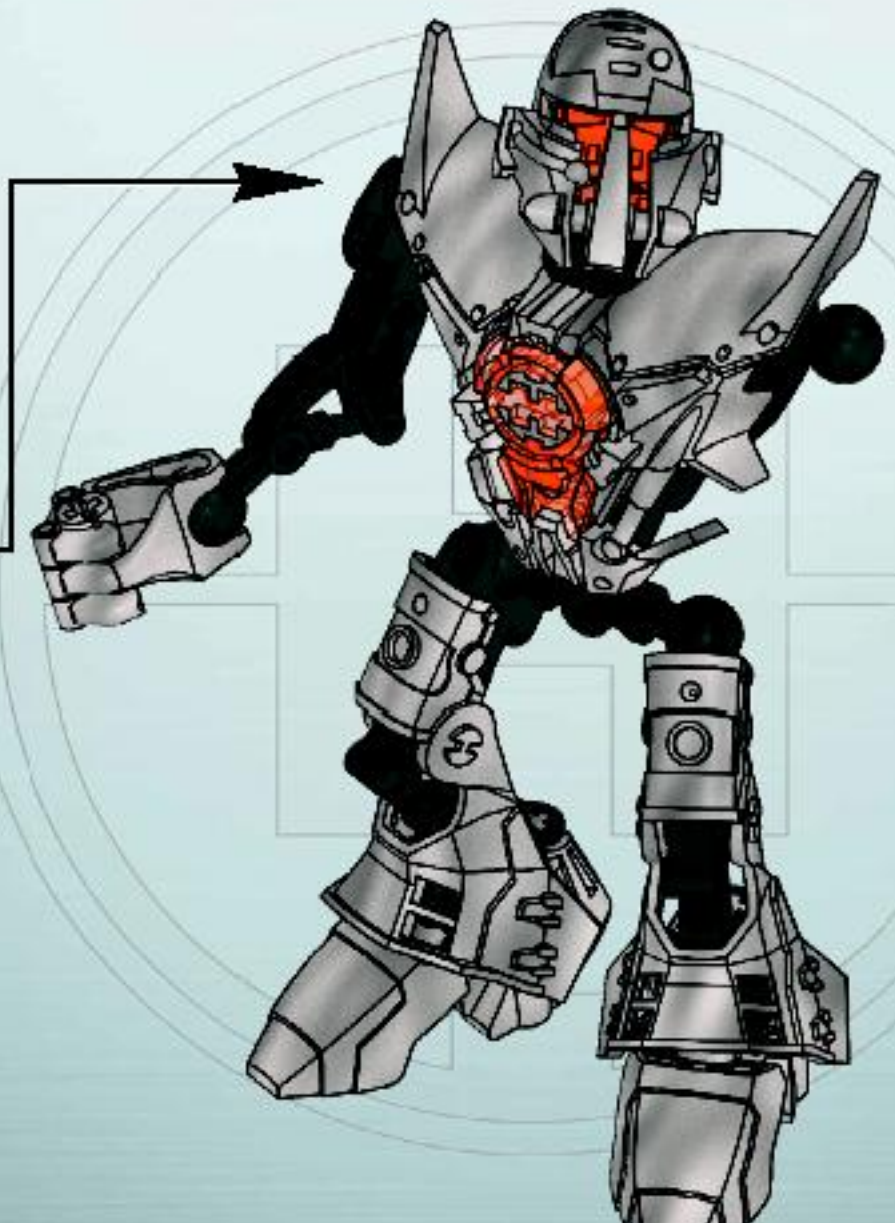

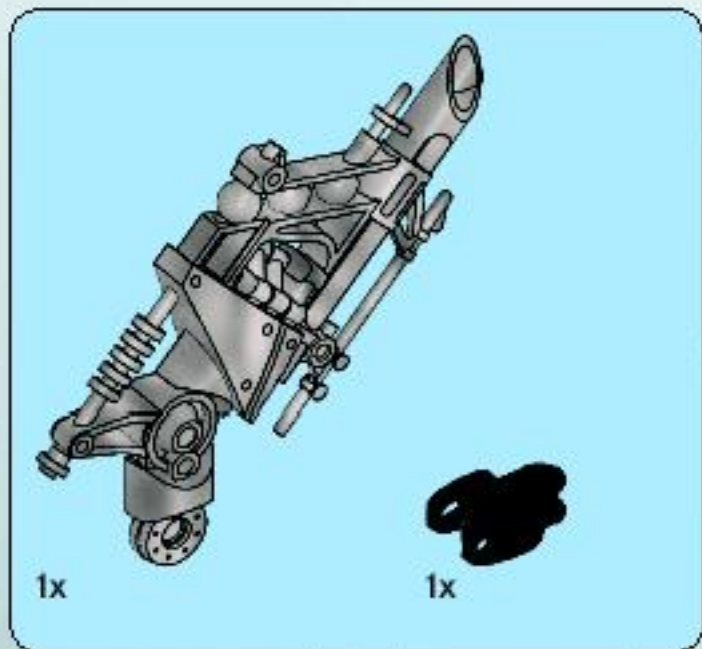

6

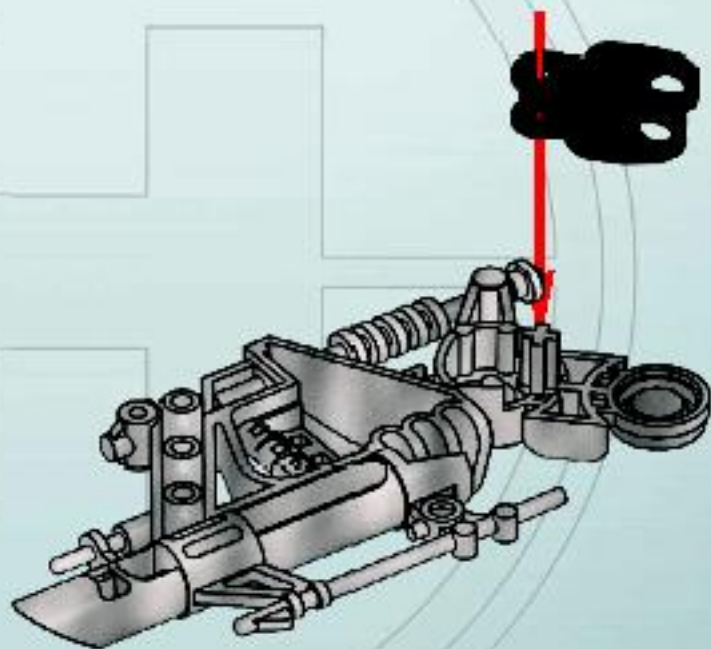

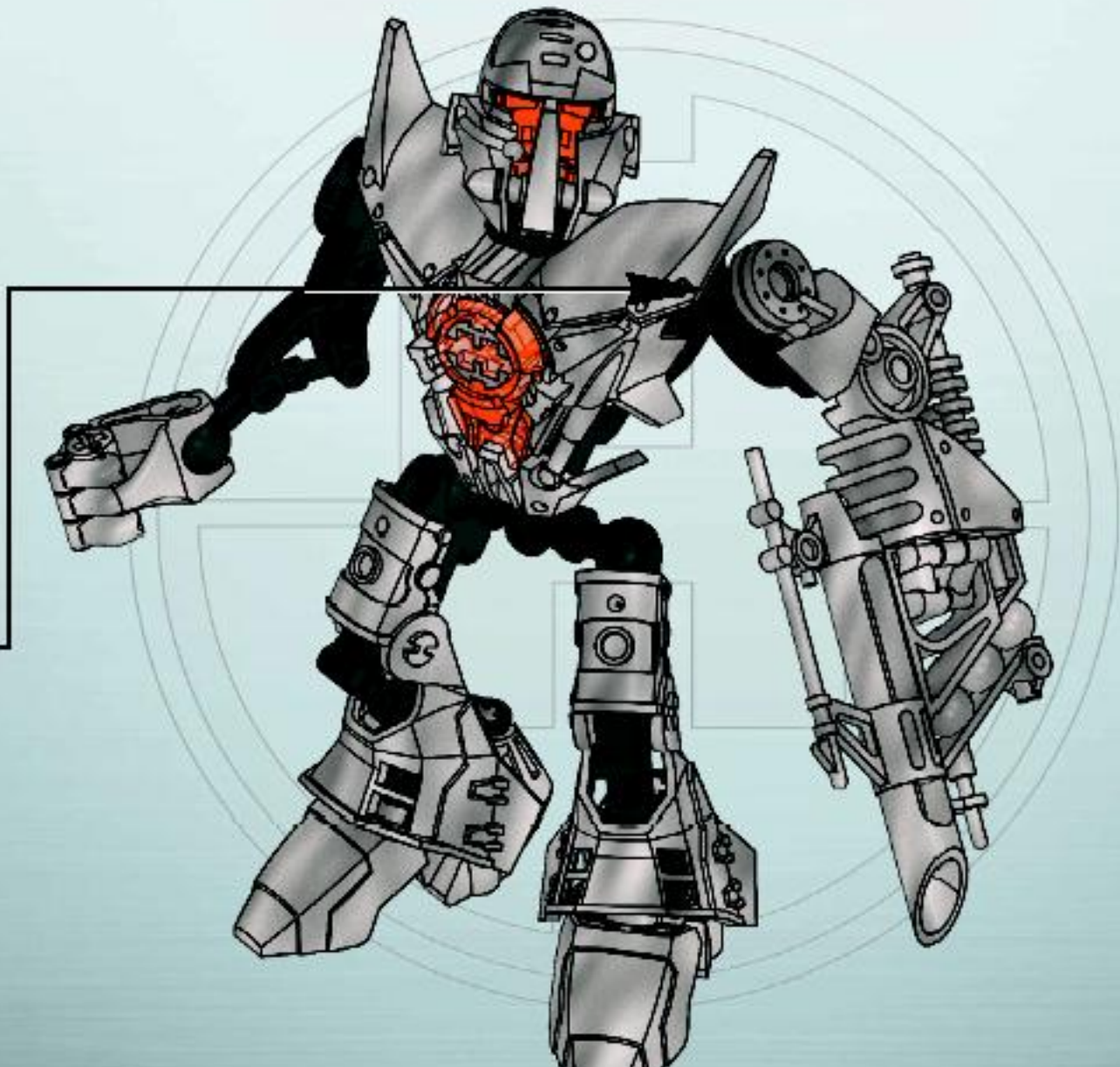



1x
4540702



1x
4581519



1x
4578958



3x
4578959



3x
4519244

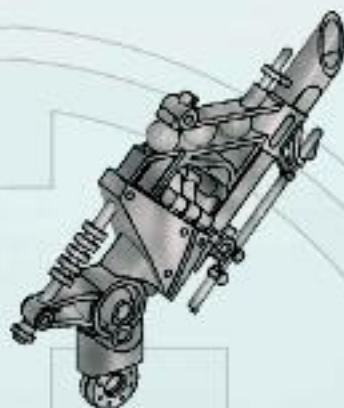

1x
4579010



2x
4582145



2x
4578963



1x
4579011



1x
4579012



1x
4545884



Customer Service

Kundenservice

Service Consommateurs

Servicio Al Consumidor

www.lego.com/service or dial



00800 5346 5555 :



1-800-422-5346 :





HERO FACTORY



HEROFACTORY.LEGO.COM

7169



7156

FREE! GRATIS! GRATUIT!



club
MAGAZINE™

www.LEGOclub.com



00800 5346 5555*        

  1-866-534-6258 • 1-877-518-5346

US & Canada only

Canada seulement

* Free phone, mobile charges may apply. * Numéro sans frais. Des frais peuvent s'appliquer avec les téléphones cellulaires.

* Gebührenfrei, Kosten für Anrufer sind in Preiskalkulationen abgedeckt. * Gratis telefonnummer vanaf eerste lijn.

* Det er ett gratis nummer, när du ringer. Pris för betaltel. * Det er gratis, når du ringer. Pris er Postbetaltel.



VISIT THE WORLD'S
BIGGEST LEGO® SHOP!

www.LEGOshop.com



WIN!

Go to www.nielsen.com/LEGO to fill out a survey for a chance to win a cool LEGO® Product. No purchase necessary. Open to all residents where not prohibited.



www.nielsen.com/LEGO

GEWINNE!

Nimm an der Umfrage auf www.nielsen.com/LEGO teil und hab die Chance ein cooles LEGO® Produkt zu gewinnen!

Die Teilnahme am Gewinnspiel führt zu keinerlei Kaufverpflichtungen. Teilnahme in allen nicht ausgeschlossenen Ländern möglich.

4590885

WIN!

Ga naar www.nielsen.com/LEGO, vul een enquêteformulier in en maak kans op een cool LEGO® product. Geen aankoopverplichting. Iedereen mag deelnemen, uitgezonderd ingezetenden van landen waar een enquêteverbod geldt.

GAGNE!

Visite www.nielsen.com/LEGO pour répondre à un questionnaire et avoir une chance de gagner un produit LEGO® très cool ! Aucune obligation d'achat. Ouvert à tous les résidents des pays autorisés.

当てよう!

www.nielsen.com/LEGO にアクセスして、アンケートにご記入ください。当選者にはレゴ製品を差し上げます。お問い合わせの必要はありません。終了されていない限り、すべての年齢にご利用いただけます。

LEGO and the LEGO logo are trademarks of the LEGO Group. ©2010 The LEGO Group. ©2010 LucasFilm Ltd. & TM. All rights reserved. Used under authorization.