



Architecture







Trevi Fountain

Rome, Italy

Fontana di Trevi

Roma, Italia



-  Booklet available in English on
-  Heft in deutscher Sprache erhältlich auf
-  Livret disponible en français sur
-  Folleto disponible en español en
-  Folheto disponível em português em
-  A füzet magyarul ezen a honlapon olvasható
-  Libretto disponibile in italiano su: [LEGO.com/Architecture](https://www.lego.com/Architecture)



Trevi Fountain Rome, Italy

The Trevi Fountain (Fontana di Trevi) is the most famous and arguably the most beautiful fountain in Rome. This impressive Baroque-styled monument was completed in 1762 and still dominates the small Trevi square located in the city's Quirinale district.





History

The imposing fountain sits at the junction of three roads, or *tre vie*, which many believe gave the fountain its name, and marks the terminal point of one of the original aqueducts that supplied water to ancient Rome. Built by Marcus Vipsanius Agrippa in 19 BC, the Aqua Virgo aqueduct was over 13 miles (21 km) long and even then had a fountain at its terminus.

The aqueduct and fountain served Rome for over 400 years, but after the invasion of the Goths in AD 537, the aqueduct was cut off and the final portion abandoned, forcing the medieval Romans to draw water from wells and the River Tiber. It would be over 1,000 years, and the advent of the Early Renaissance period, before a fountain would again stand in the location we know today.



© Getty Images



Design & Construction

Many smaller fountains were constructed between 1400 and 1700, almost all of them at the behest of the reigning pope. It was also Pope Clement XII who organized a competition in 1730 to build a more dramatic fountain. Many of the most renowned architects of the day entered the competition, which architect Nicola Salvi eventually won.

With a budget of 17,647 Scudo (the Papal State's currency), work began in 1732. Unfortunately, neither Clement XII nor Salvi would live to see the work completed. It was Pietro Bracci who, under the guardianship of Clement XIII, would complete the project. The magnificent fountain that we know today was officially opened on Sunday, May 22, 1762.

The central theme of this impressive fountain is the *Taming of the Waters*. In a mix of water and

rockwork, Tritons guide *Oceanus*' shell chariot, taming the horses, or hippocampi, of the sea. A triumphal arch with three niches holds the fountain's main statues. The center niche frames *Oceanus* and includes freestanding columns for maximal light and shade. In the niches flanking *Oceanus*, *Abundance* spills water from her urn and *Salubrity* holds a cup from which a snake drinks. Above, bas-reliefs illustrate the Roman origin of the aqueducts.

The 86 ft. (26.3 m) tall and 161.3 ft. (49.15 m) wide fountain is superimposed on a backdrop of the elegant Palazzo Poli. The palace was given a new facade to match the fountain and today houses the National Institute of Graphic Art.



The Trevi Fountain Today

The Trevi Fountain has become an iconic symbol of Rome and remains one of the city's most popular tourist attractions. A traditional legend holds that if visitors throw a coin into the fountain, they are ensured a return to Rome. It is estimated that 3,000 euros are thrown into the fountain each day.

The fountain has provided a backdrop for many classic movies, including Hollywood's 1954 romantic comedy, *Three Coins in a Fountain*, and Federico Fellini's famous 1960 *La Dolce Vita*. Part of the fountain is also replicated at the Italy Pavilion at Epcot in Walt Disney World in the US.

The fountain was refurbished in 1998; the stonework was scrubbed and all cracks and other areas of deterioration were repaired by skilled artisans, and the fountain was equipped with recirculating pumps.

In January 2013, it was announced that the Italian fashion company Fendi would sponsor a 20-month, € 2.2 million restoration of the fountain; it will be the most thorough restoration in the fountain's history.



The Architects

Little of Nicola Salvi's (1697–1751) work beyond the Trevi Fountain remains today and relatively little is known of the architect himself. He was admitted to the Roman Academy of Arcadia in 1717 and only became an architect after studying mathematics and philosophy. His friend and colleague, the sculptor Pietro Bracci (1700–1773), would eventually go on to complete the fountain. Bracci's most famous piece of work, the statue of Oceanus, forms the centerpiece of the fountain.

Facts about the Trevi Fountain

Location: Rome, Italy
People: Pope Clement XII,
Pope Clement XIII,
Nicola Salvi,
Pietro Bracci
Construction Period: 1732 to 1762
Measurements: Height 86 ft. (26.3 m)
Width 161.3 ft. (49.15 m)
Materials: Travertine stone



© Shutterstock





Fontana di Trevi Roma, Italia

La Fontana di Trevi è la più famosa e forse la più bella fontana di Roma. Questo imponente monumento in stile barocco, completato nel 1762, domina ancora oggi la piccola piazza di Trevi nel quartiere del Quirinale.





Storia

L'imponente fontana si trova all'incrocio di tre strade, o *trivium*, dal quale probabilmente il monumento ha preso il suo nome, e il punto terminale di uno degli acquedotti che rifornivano di acqua l'antica Roma. Costruito da Marco Vipsanio Agrippa nel 19 a.C., l'acquedotto Aqua Virgo misurava oltre 20 km di lunghezza e anche a quel tempo la fontana era il suo punto terminale.

L'acquedotto e la fontana hanno servito Roma per più di 400 anni, ma dopo l'invasione dei Goti nel 537 d.C., l'acquedotto fu danneggiato e la sezione finale abbandonata, costringendo i romani dei tempi medievali ad attingere l'acqua dai pozzi e dal fiume Tevere. Sarebbero trascorsi più di 1.000 anni, all'inizio dell'epoca rinascimentale, prima che la fontana fosse restaurata nell'esatta posizione odierna.



© Getty Images



Progettazione e costruzione

Molte piccole fontane furono costruite tra il 1400 e il 1700 e quasi tutte per volere del papa regnante. Nel 1730, Papa Clemente XII bandì un concorso per la costruzione di una importante mostra d'acqua. Molti dei più noti architetti dell'epoca parteciparono al concorso, che alla fine fu assegnato a Nicola Salvi.

Con un finanziamento di 17.647 scudi (la moneta dello Stato Pontificio), i lavori iniziarono nel 1732. Sfortunatamente, né Clemente XII né Salvi avrebbero visto la conclusione dell'opera. Fu Pietro Bracci che, sotto la tutela di Clemente XIII, avrebbe completato il progetto. La magnifica fontana che conosciamo oggi fu inaugurata ufficialmente il 22 maggio 1762, una domenica.

Il tema centrale è quello del mare. La scena principale è dominata da una scogliera rocciosa, su cui si trova il cocchio a forma di conchiglia

di Oceano, trainato da due cavalli alati, a sua volta guidati da tritoni. Un arco trionfale, con tre nicchie, ospita le statue principali della fontana. La nicchia centrale incornicia Oceano e include quattro grandi colonne individuali per la massima illuminazione e ombreggiatura. Nelle nicchie laterali, troviamo la statua dell'Abbondanza, intenta a versare acqua dalla sua urna, e quella della Salubrità, con in mano una coppa alla quale si disseta un serpente. Sopra le statue, alcuni bassorilievi illustrano l'origine romana degli acquedotti.

Alle spalle della fontana, alta 26,3 m e larga 49,15 m, si erge l'elegante Palazzo Poli. Una nuova facciata fu realizzata per il palazzo per abbinarla allo stile architettonico della fontana; attualmente ospita l'Istituto Nazionale per la Grafica.



La Fontana di Trevi oggi

La Fontana di Trevi è diventata un simbolo iconico di Roma ed è una delle più popolari attrazioni turistiche della città. Una leggenda vuole che i visitatori che lanciano una moneta nella fontana si propizieranno un futuro ritorno a Roma. È stato calcolato che monetine per un valore di circa 3.000 euro siano gettate ogni giorno nella fontana.

La fontana ha fatto da sfondo a numerosi film classici, tra cui la commedia romantica di Hollywood del 1954, *Tre soldi nella fontana*, e ovviamente *La Dolce Vita* di Federico Fellini, del 1960. Parte della fontana è stata anche replicata al Padiglione Italia del Walt Disney World, a Epcot, negli Stati Uniti.

La fontana è stata restaurata nel 1998; le sezioni in pietra sono state pulite e tutte le crepe e altre aree di degrado sono state riparate da esperti artigiani; la fontana è stata infine dotata di pompe di ricircolo.

Nel gennaio del 2013, è stato annunciato che Fendi, la famosa casa di moda italiana, avrebbe sponsorizzato un progetto di restauro della durata di 20 mesi e del valore di € 2,2 milioni; si tratterà del restauro più meticoloso della storia della fontana.



Gli architetti

Poche tracce dell'opera di Nicola Salvi (1697–1751) – oltre naturalmente alla Fontana di Trevi – rimangono oggi e anche le notizie sull'architetto scarseggiano. Ammesso all'Accademia dell'Arcadia romana nel 1717, si dedicò all'architettura solo dopo aver studiato matematica e filosofia. Fu il suo amico e collega, lo scultore Pietro Bracci (1700-1773), a completare la fontana dopo la sua morte. L'opera più famosa di Bracci, la statua di Oceano, è il fulcro della Fontana di Trevi.

Alcuni dati sulla Fontana di Trevi

Ubicazione: Roma, Italia
Personaggi: Papa Clemente XII,
Papa Clemente XIII,
Nicola Salvi,
Pietro Bracci
Periodo di costruzione: 1732-1762
Dimensioni: Altezza 26,3 m
Larghezza 49,15 m
Materiali: Travertino



© Shutterstock



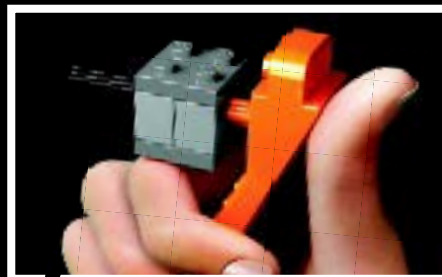
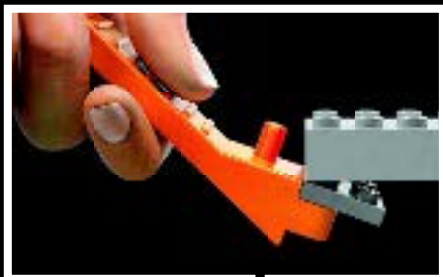

[LEGO.com/brickseparator](https://www.lego.com/brickseparator)

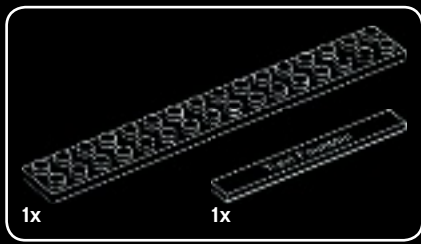

1

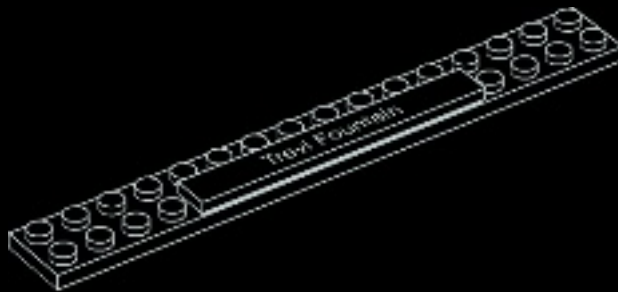

The Palazzo Poli in the background blends perfectly with the fountain and today houses the National Institute of Graphic Art.

Il Palazzo Poli, alle spalle della fontana, si abbina perfettamente al suo stile architettonico; attualmente ospita l'Istituto Nazionale per la Grafica.



© shutterstock

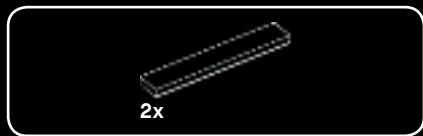

2

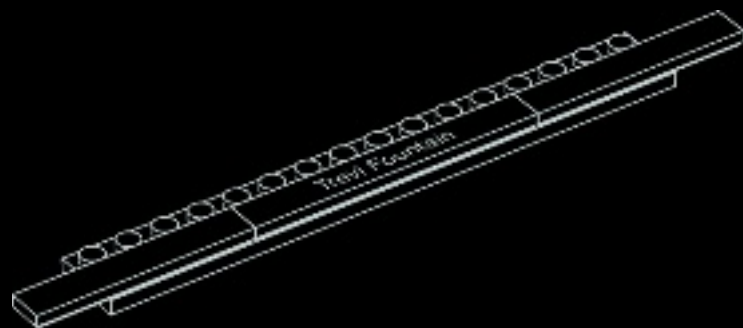

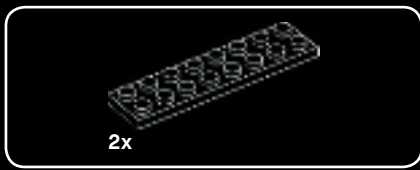

3

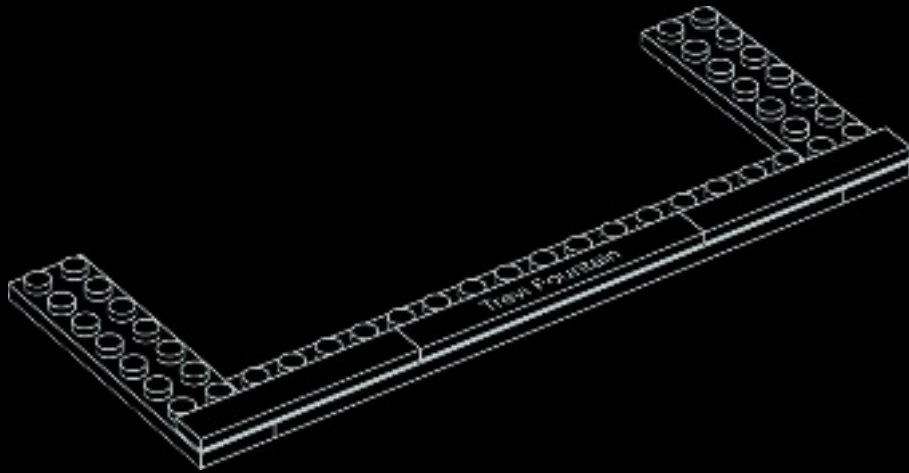



4

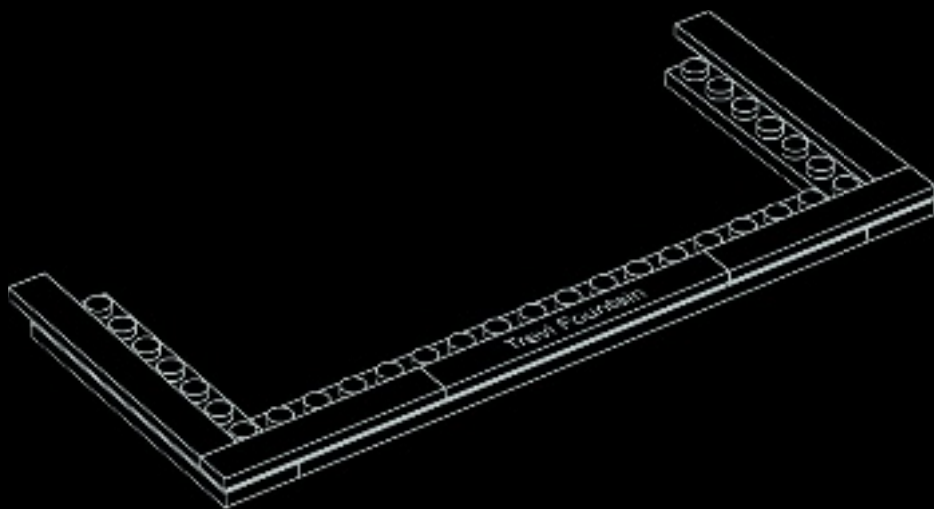

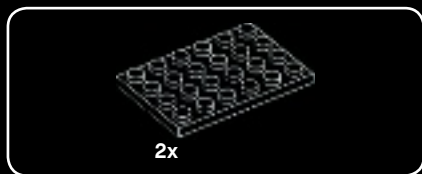

5

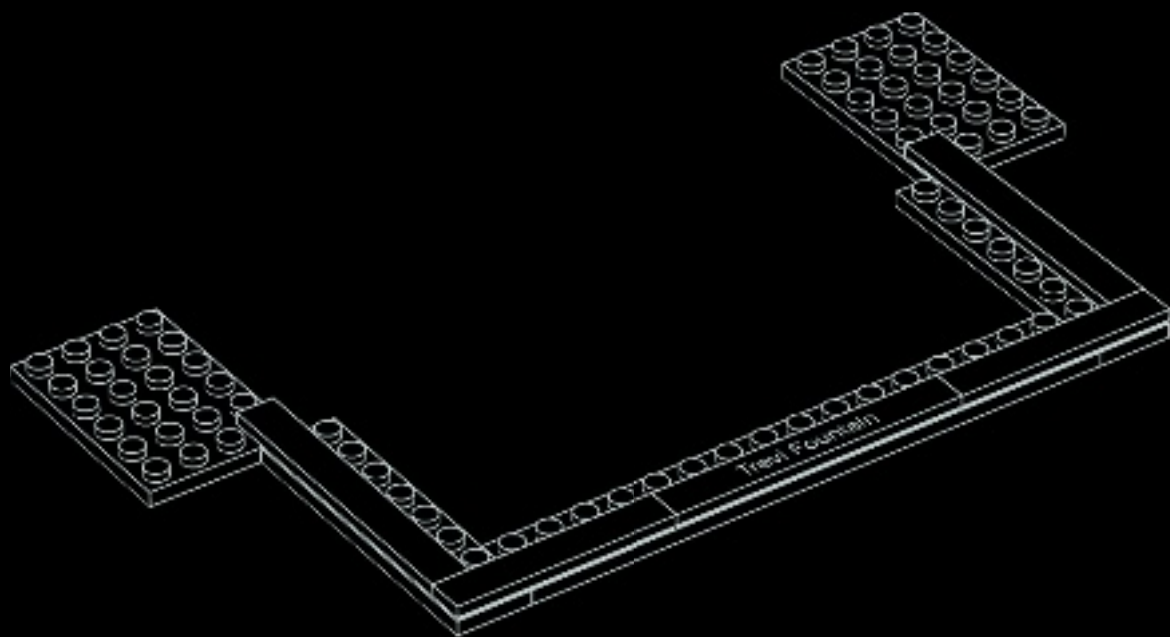



6

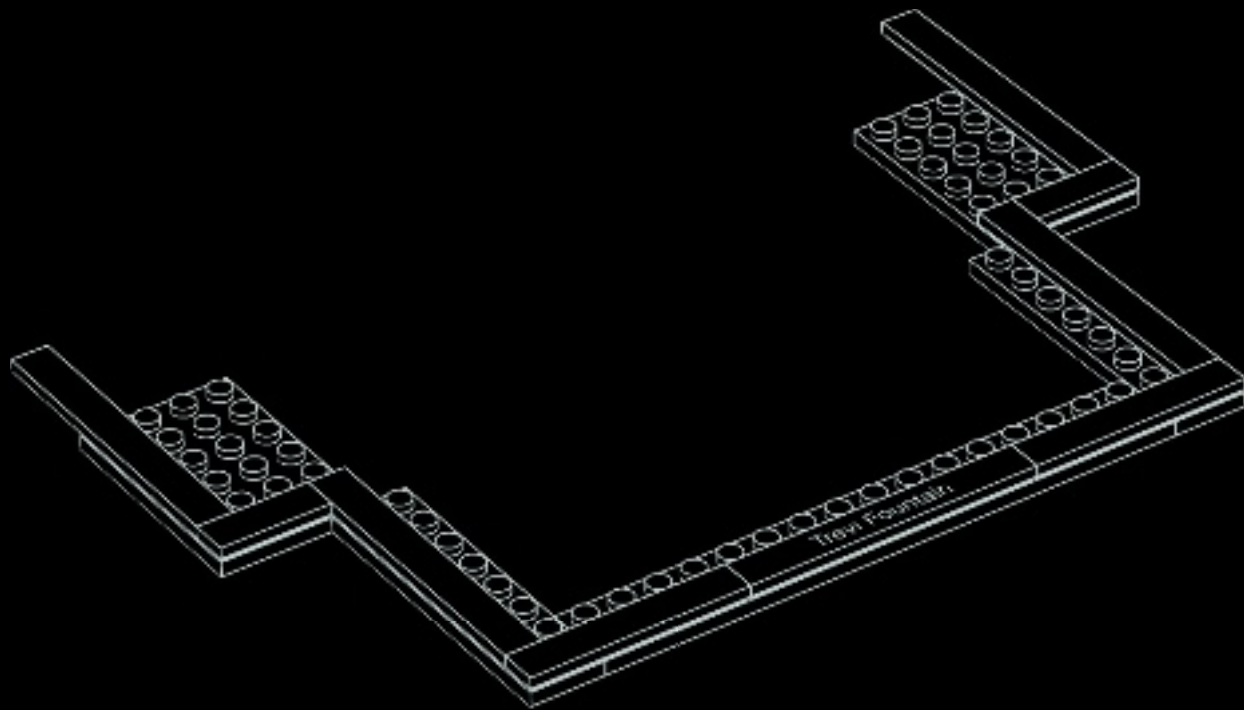

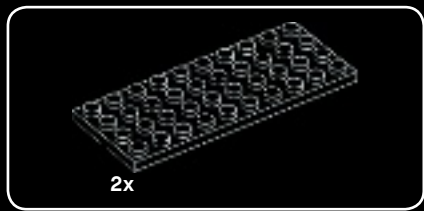

7

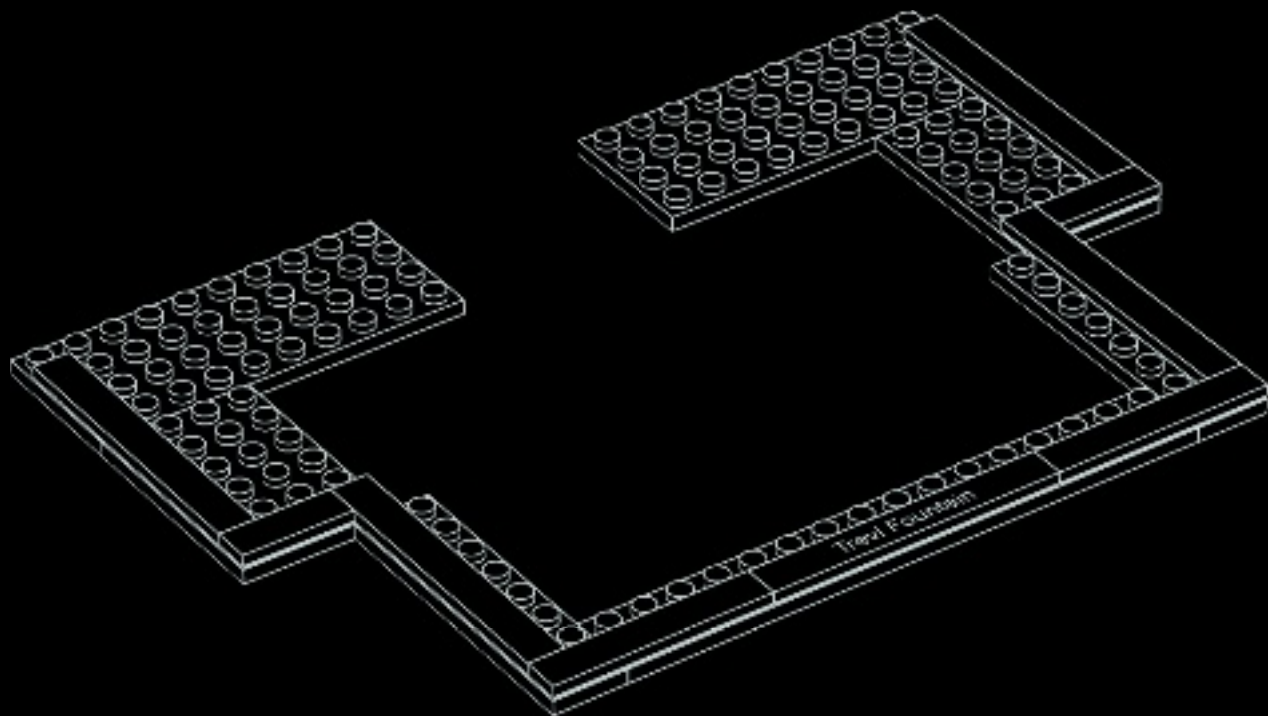



8

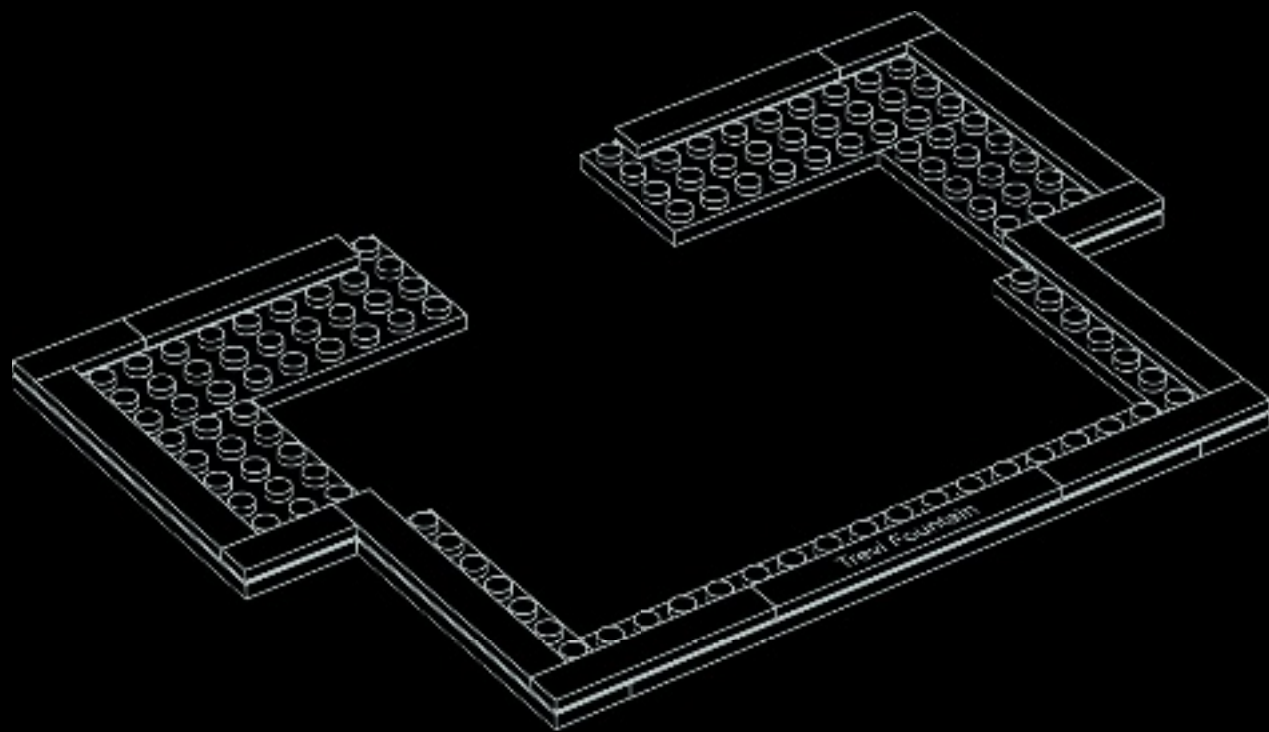

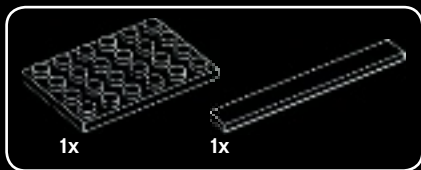

9

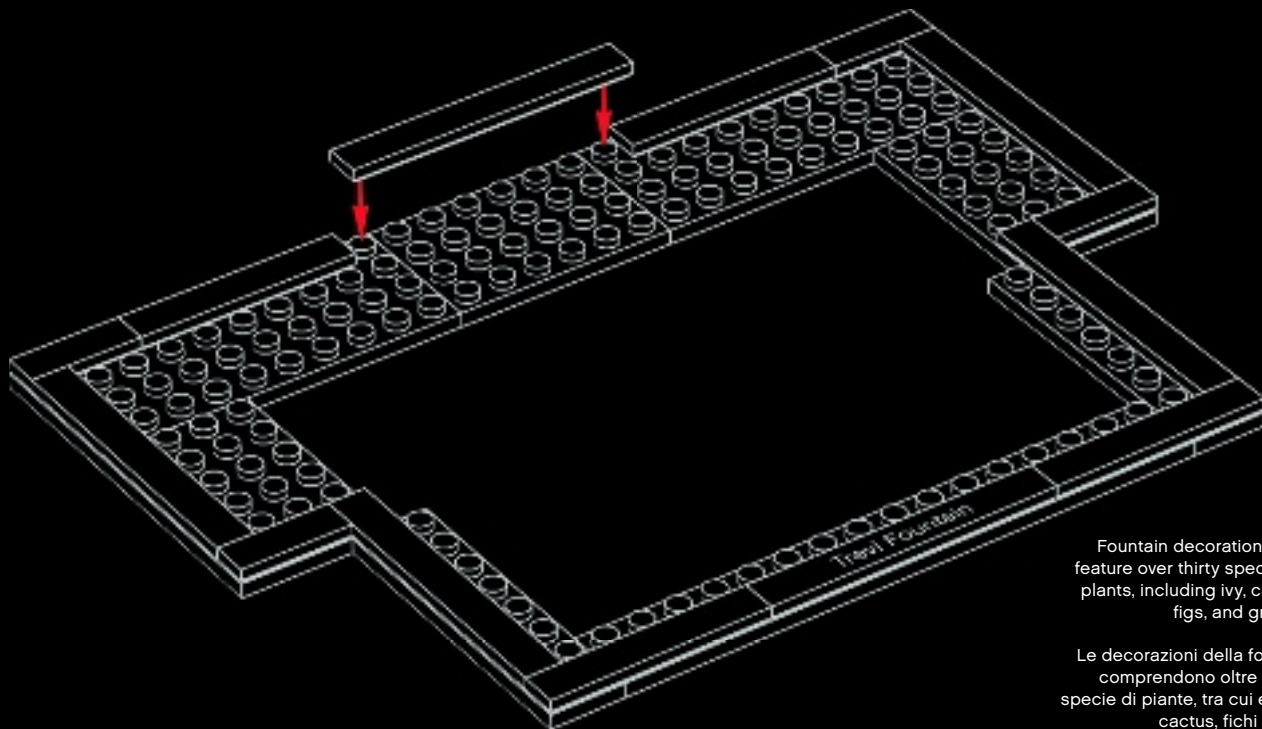

Fountain decorations also feature over thirty species of plants, including ivy, cactus, figs, and grapes.

Le decorazioni della fontana comprendono oltre trenta specie di piante, tra cui edera, cactus, fichi e uva.





2x



2x

10

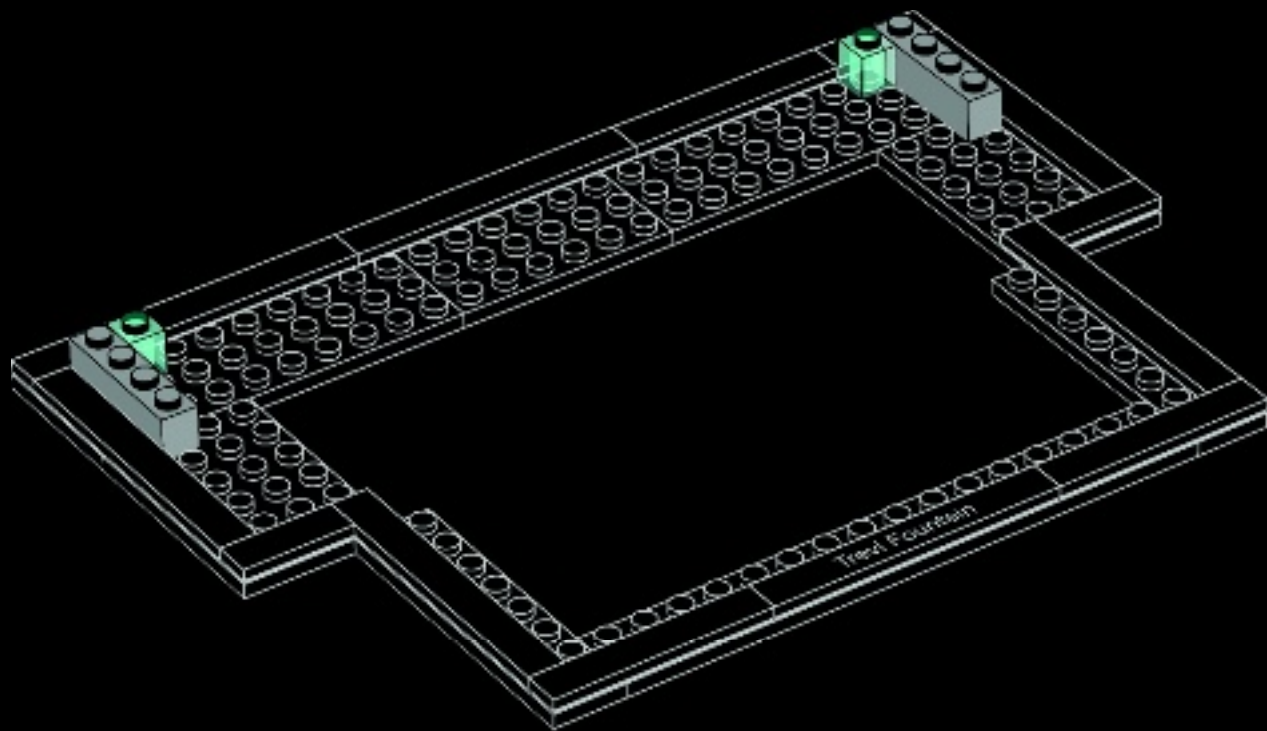

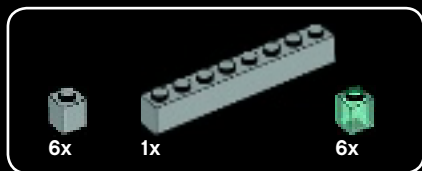

11

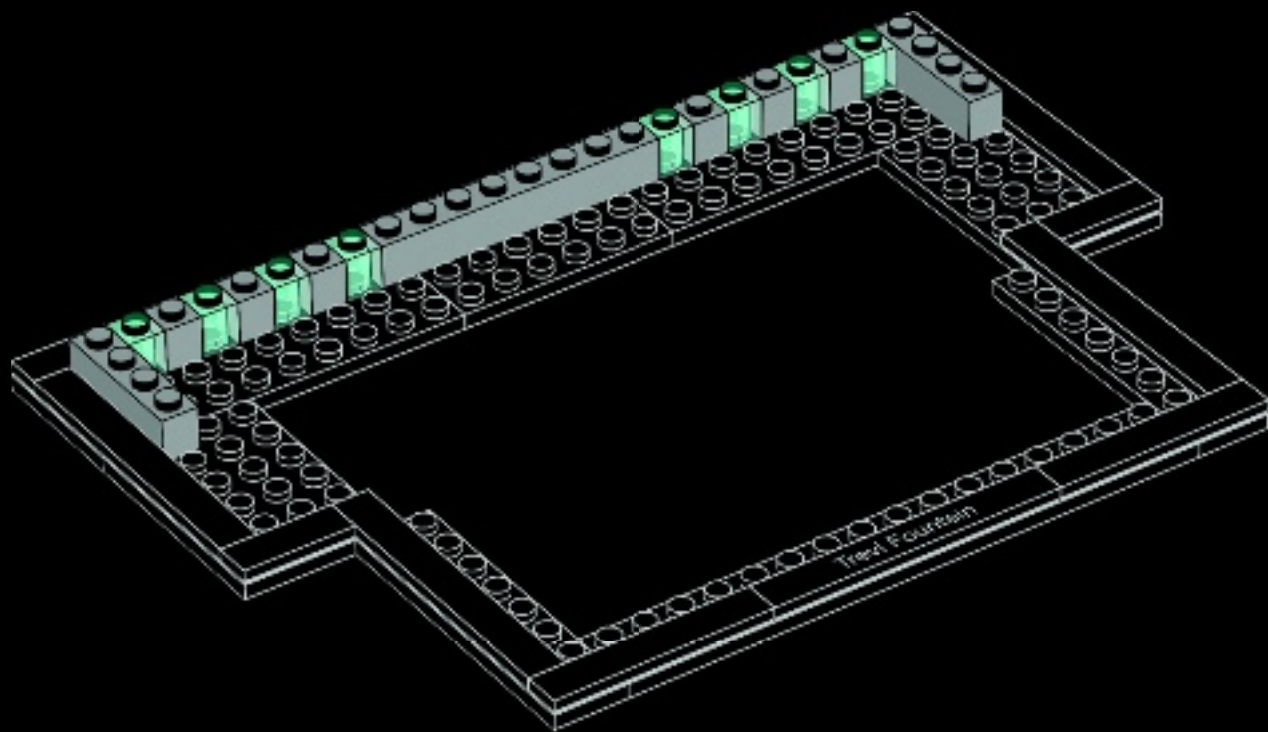

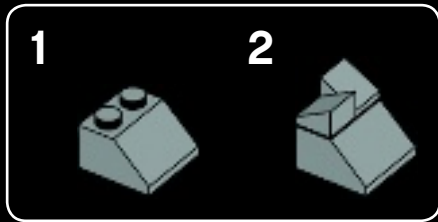

12

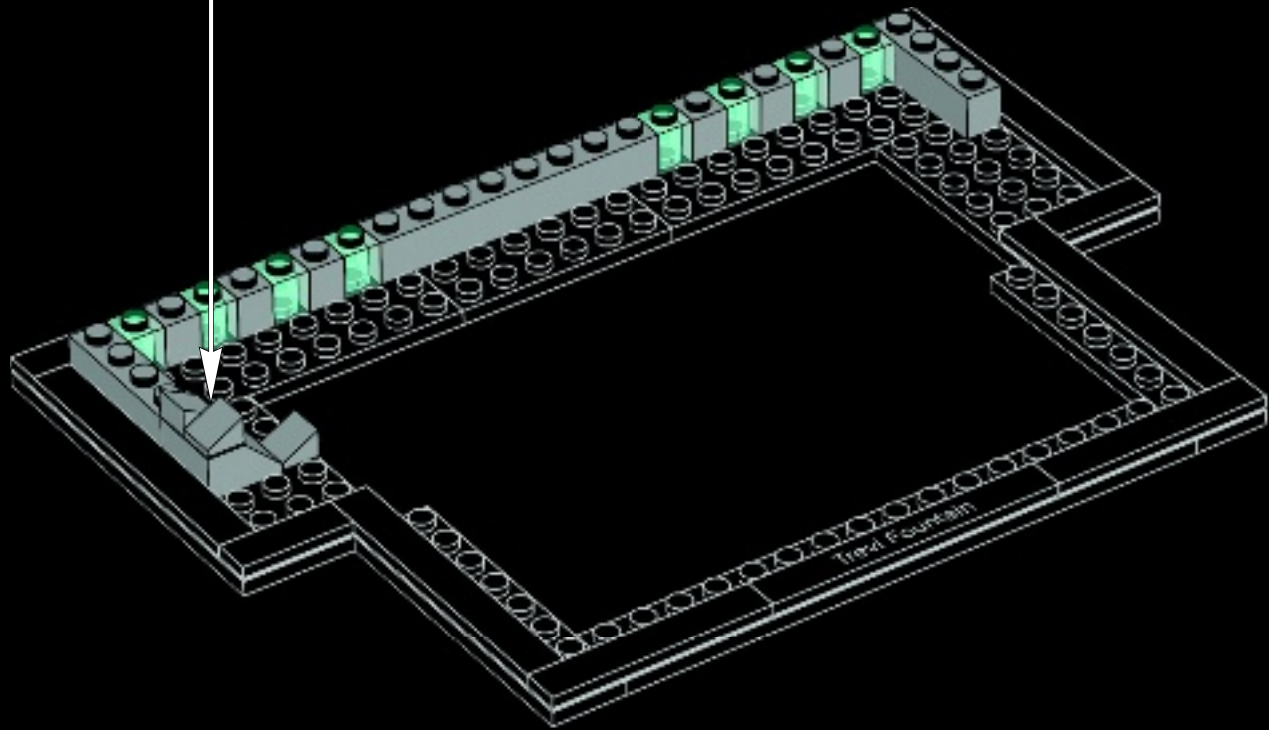



1x



2x

13

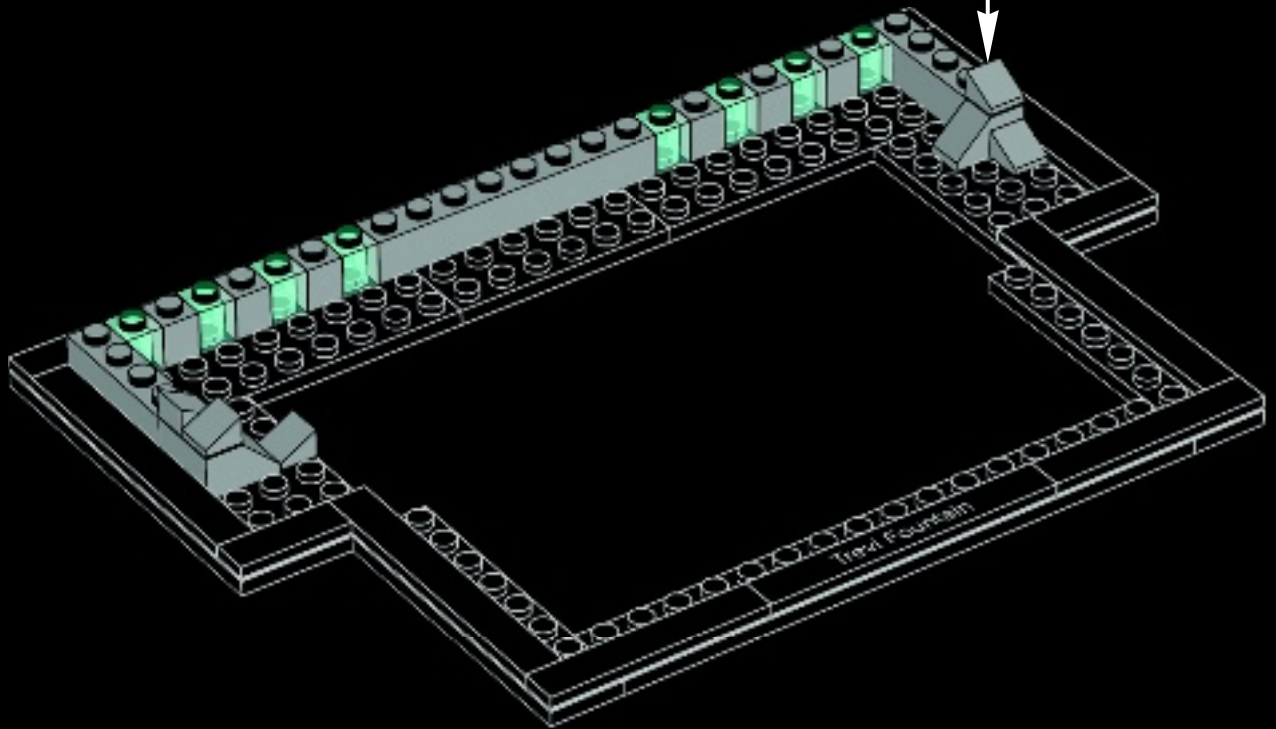
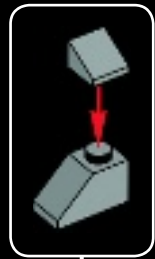



14

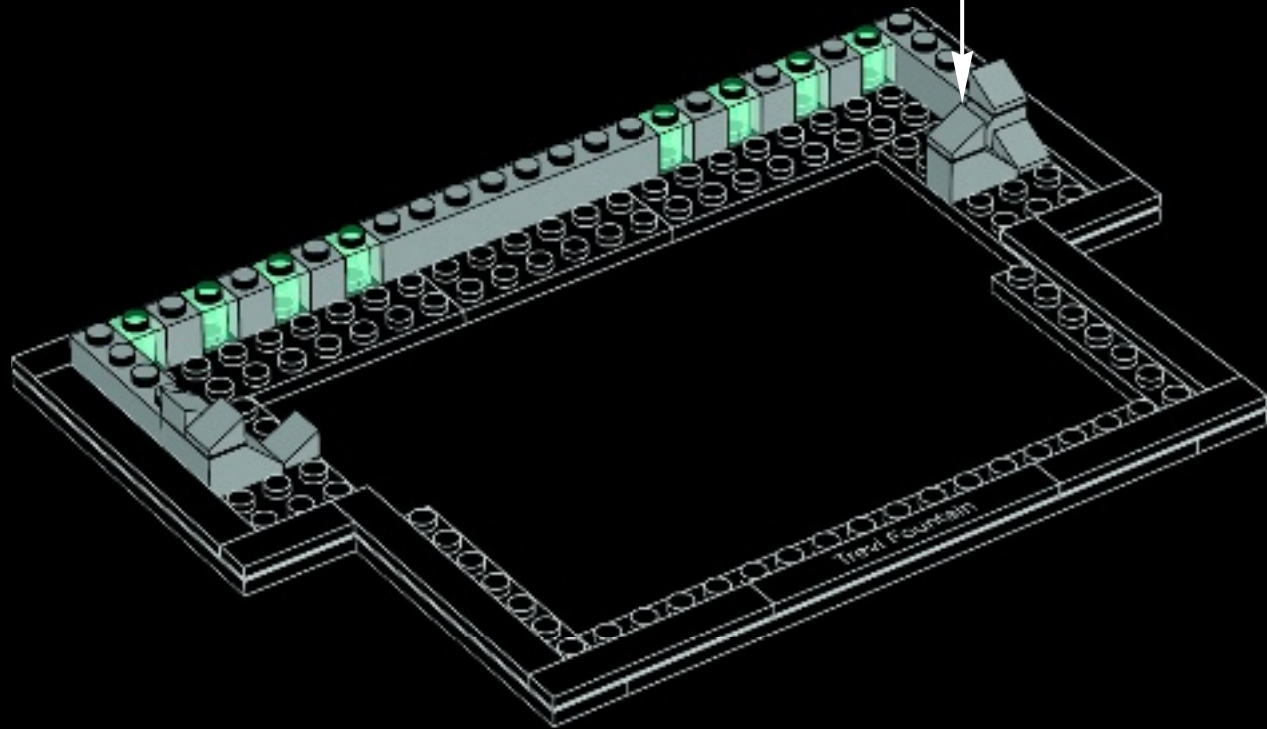
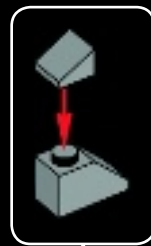

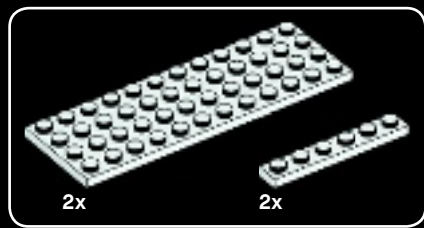

15

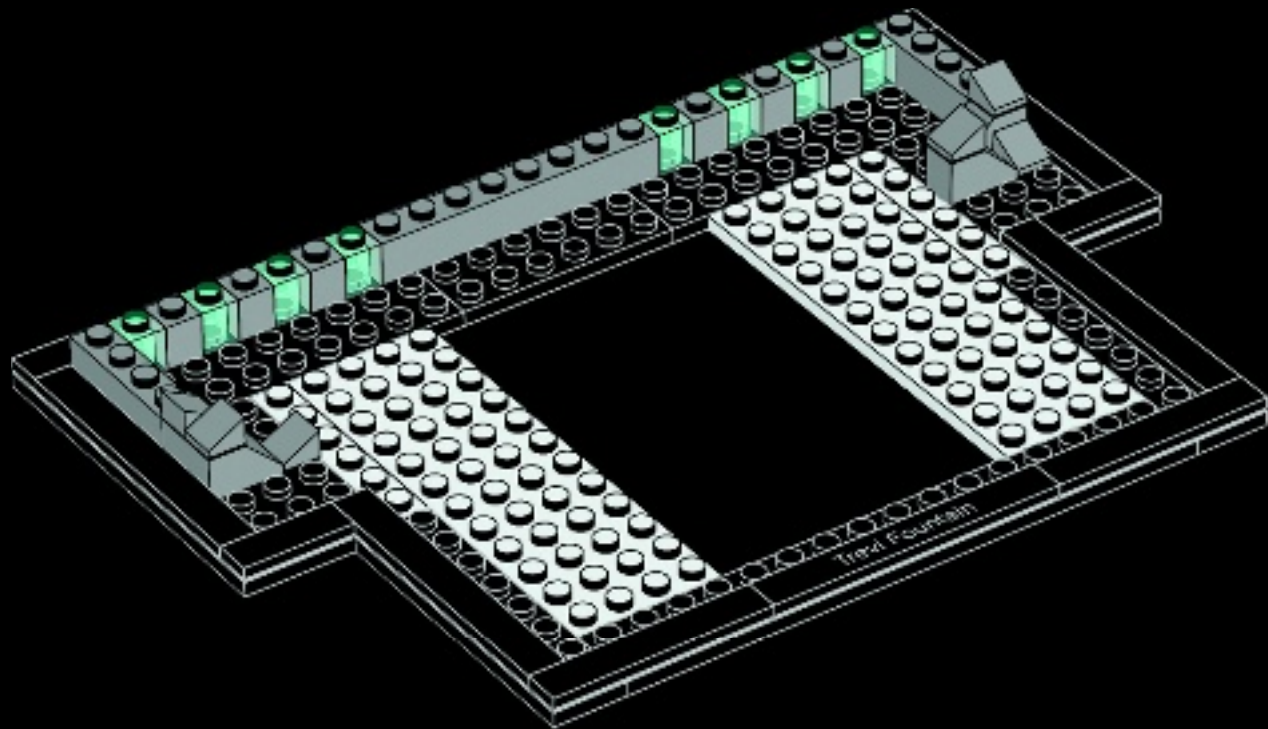

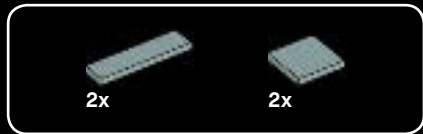

16

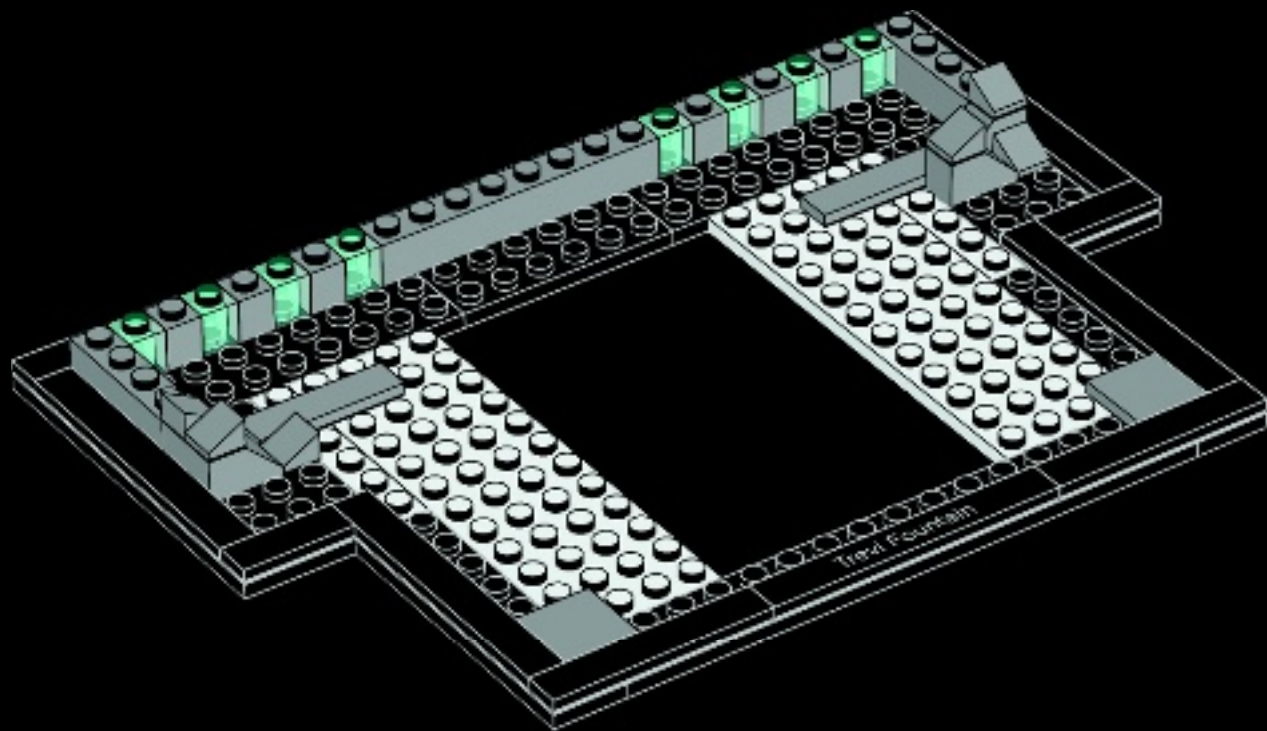



8x

17

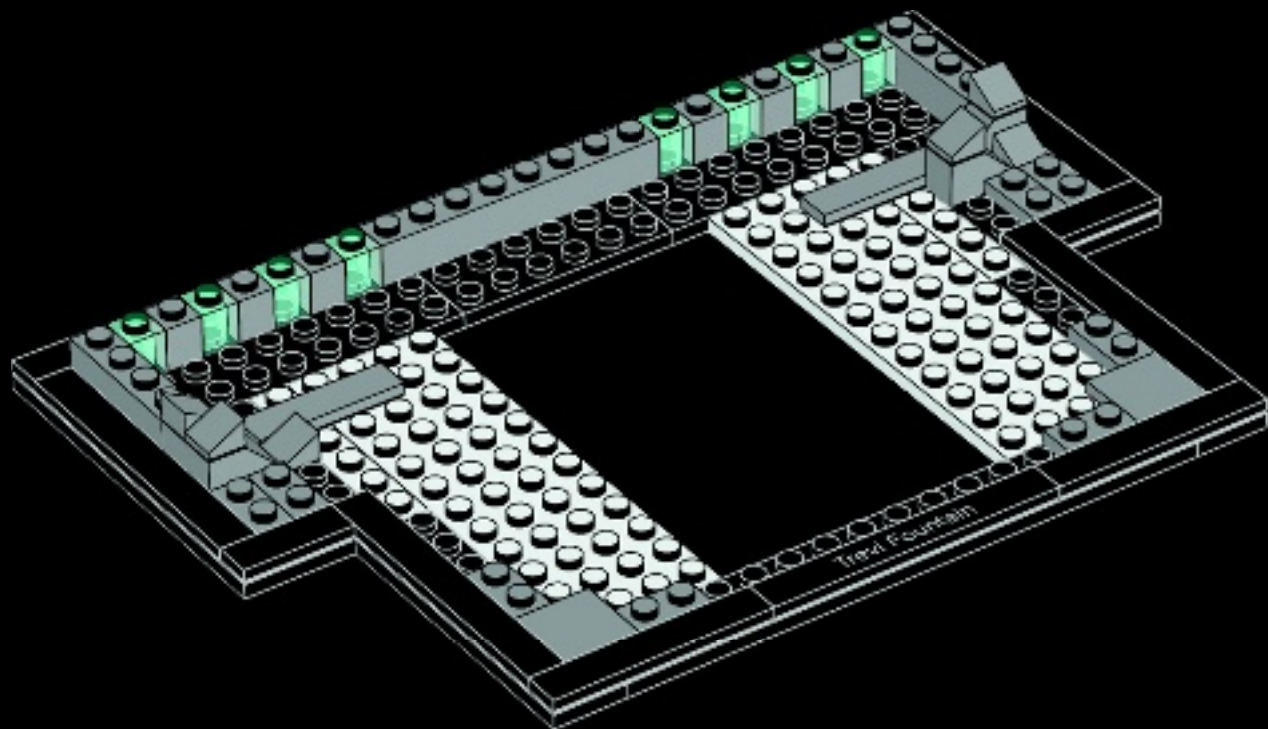



18

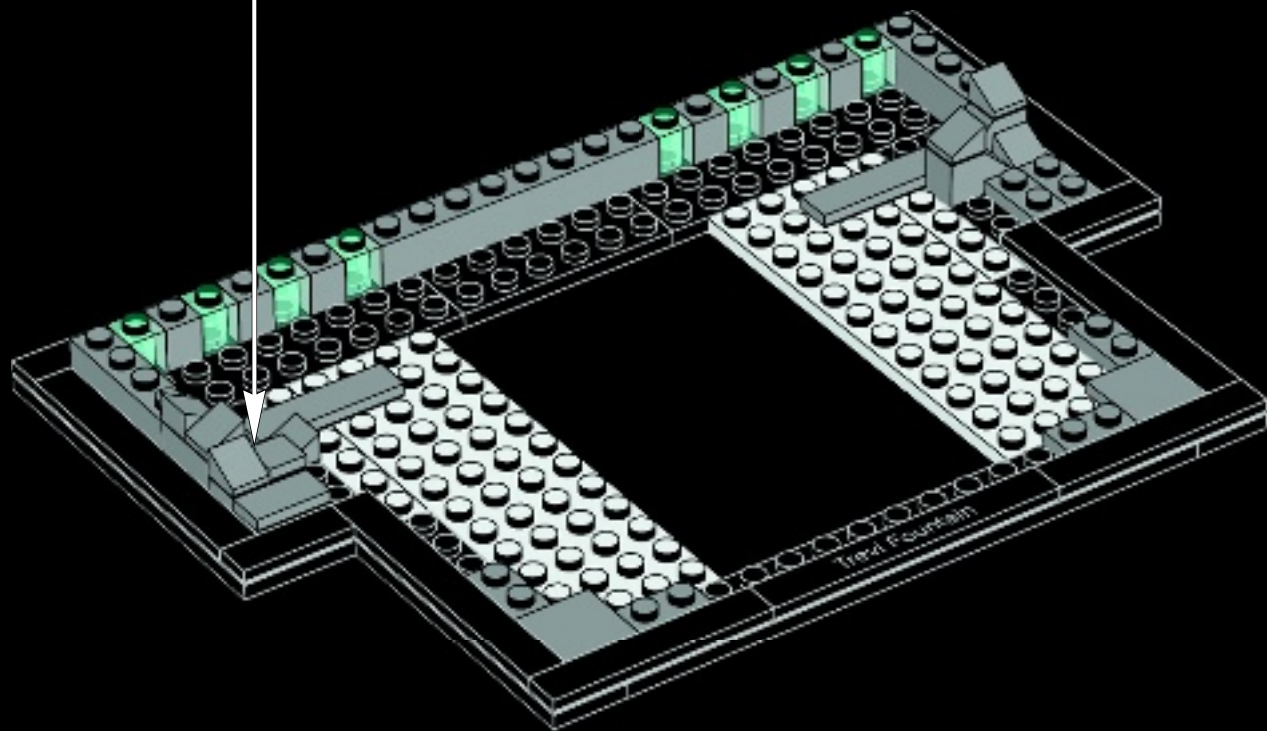



19

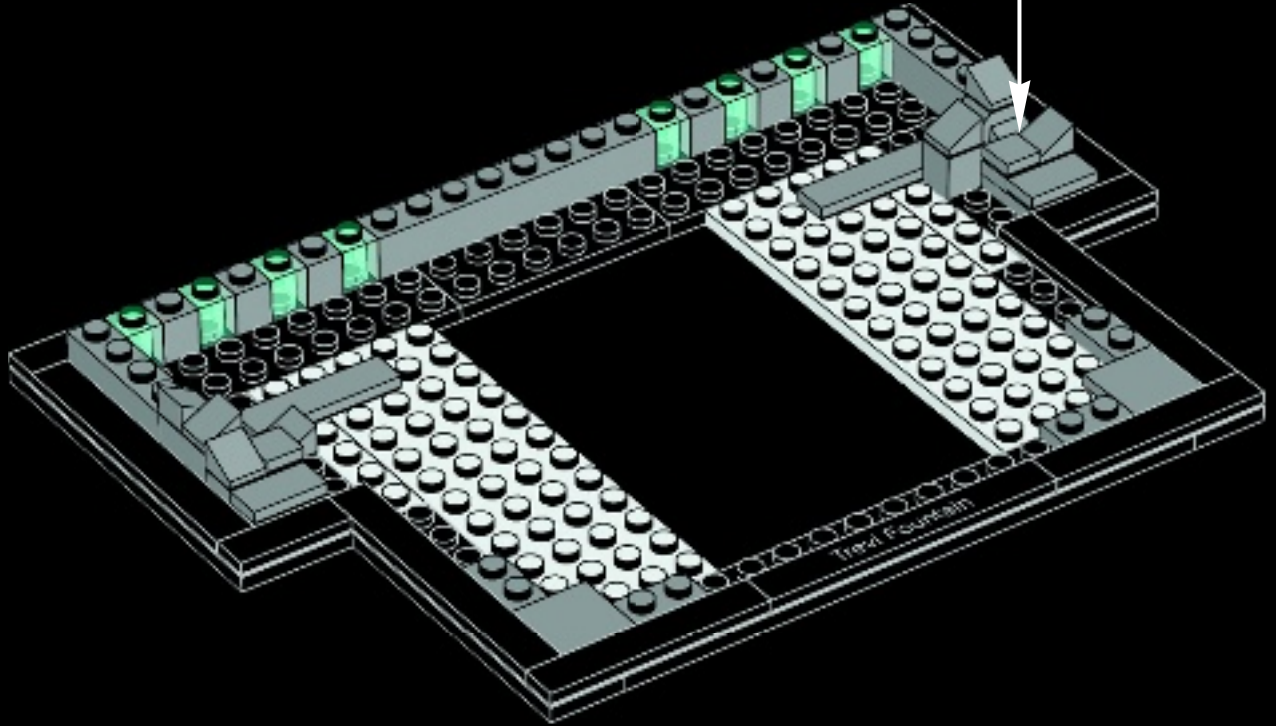
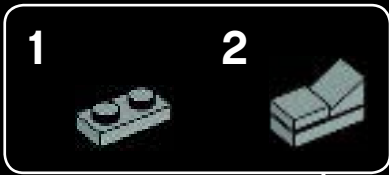



6x



4x



2x

20

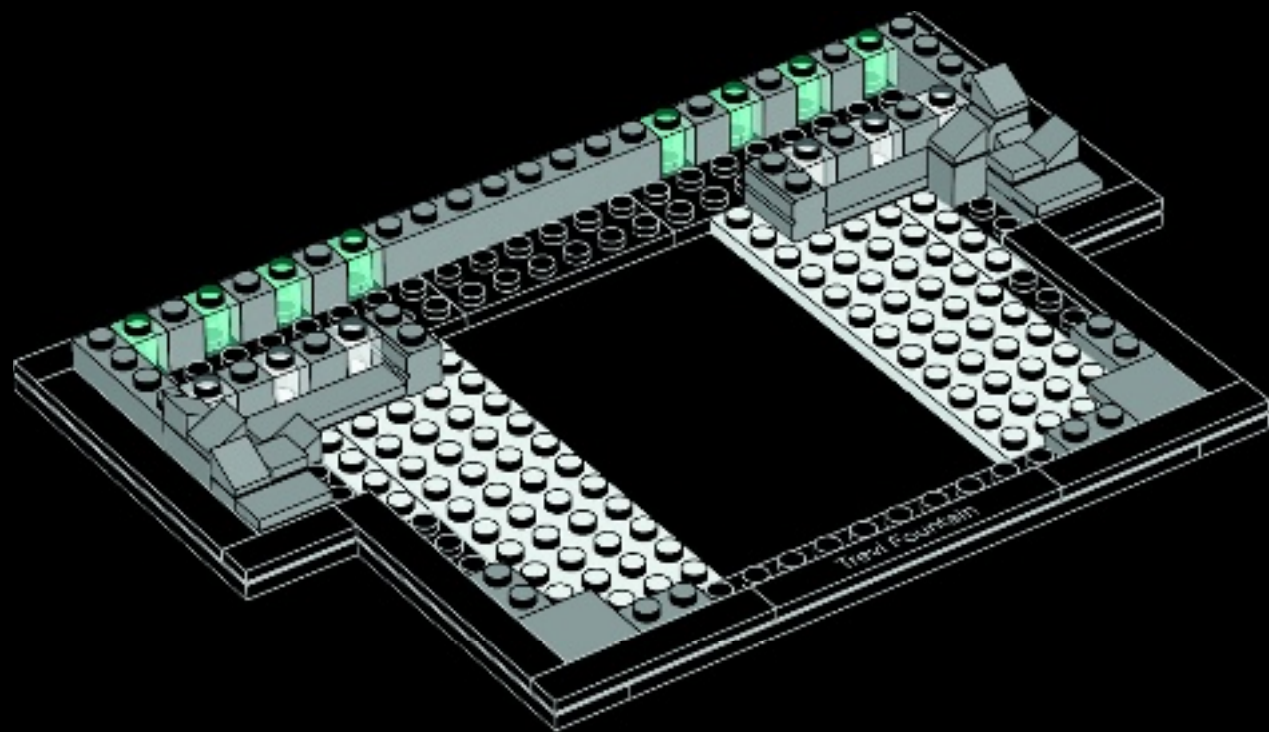

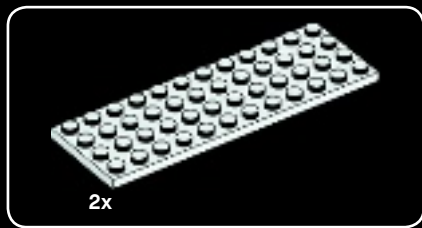

21

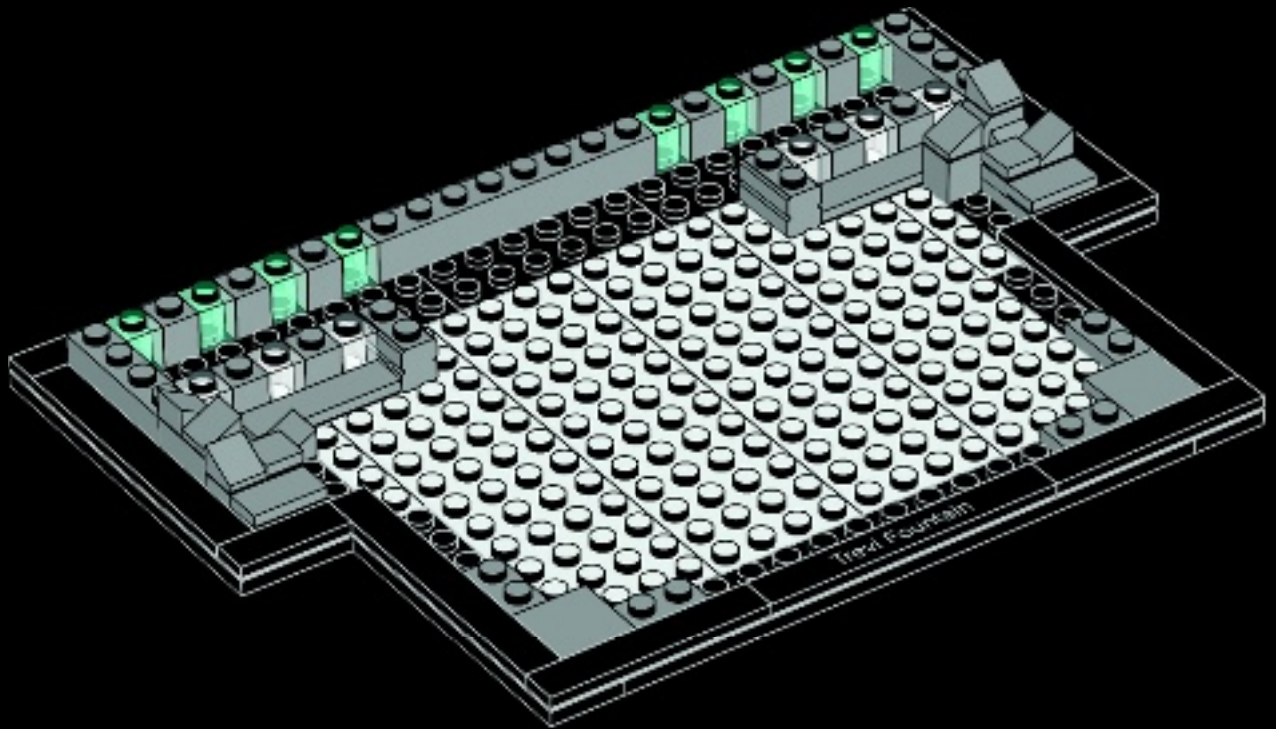



22

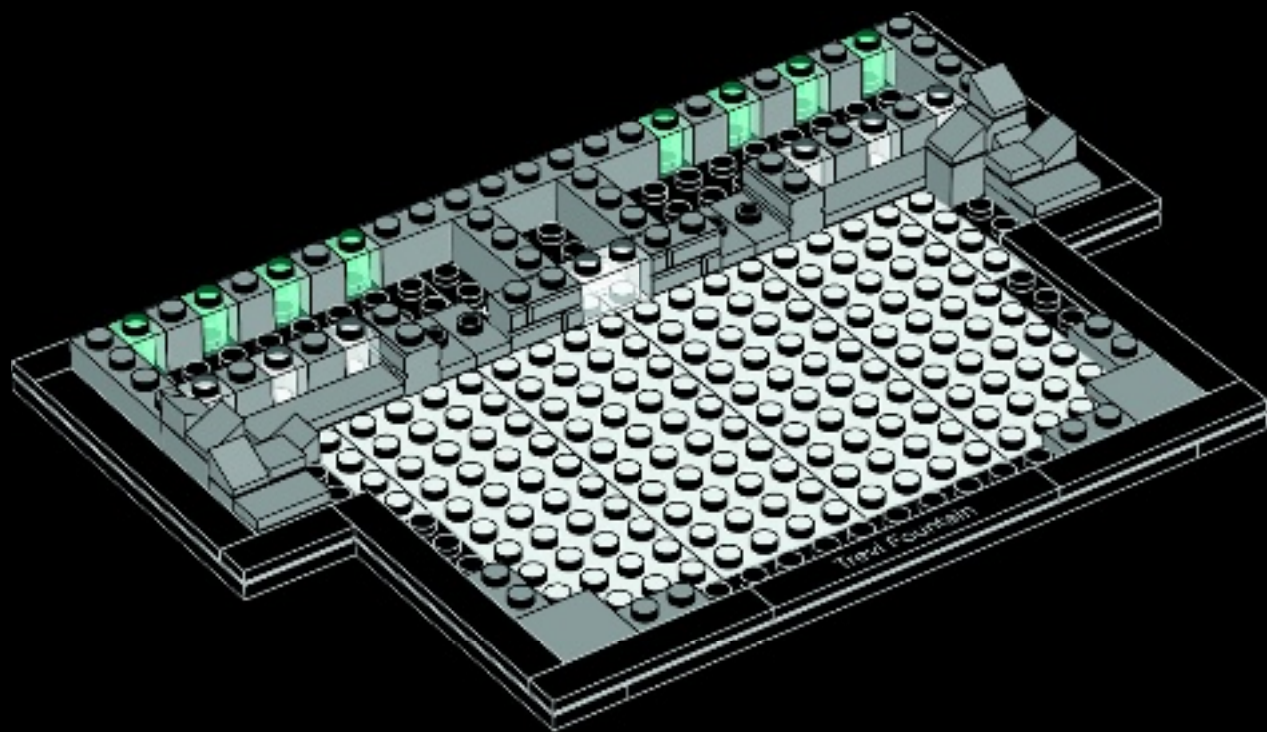



3x



2x

23

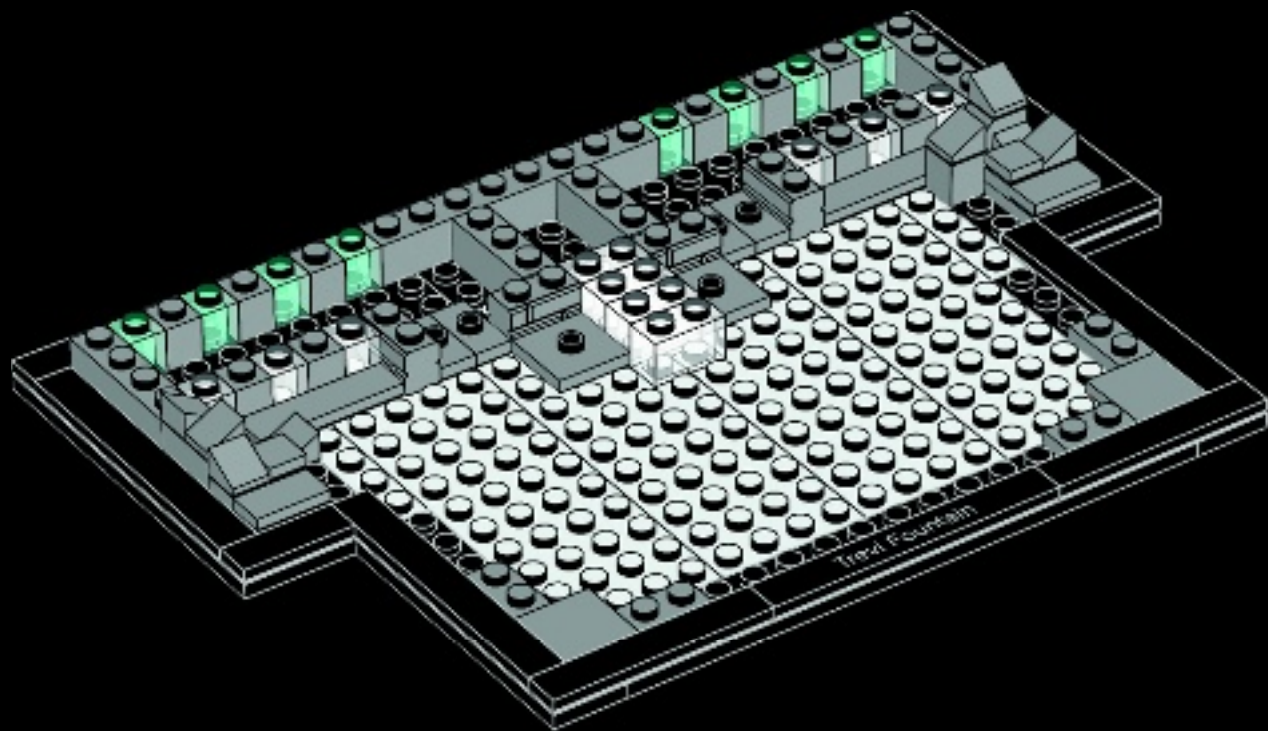



24

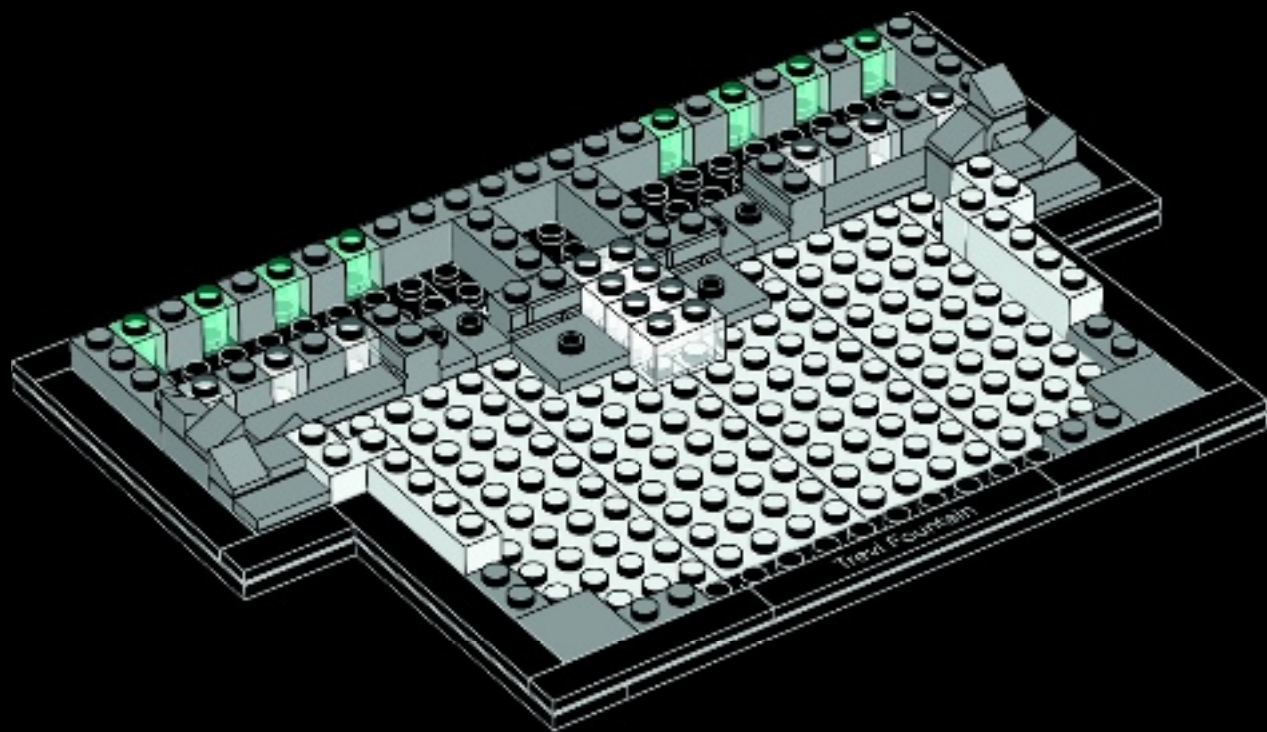



11x

25

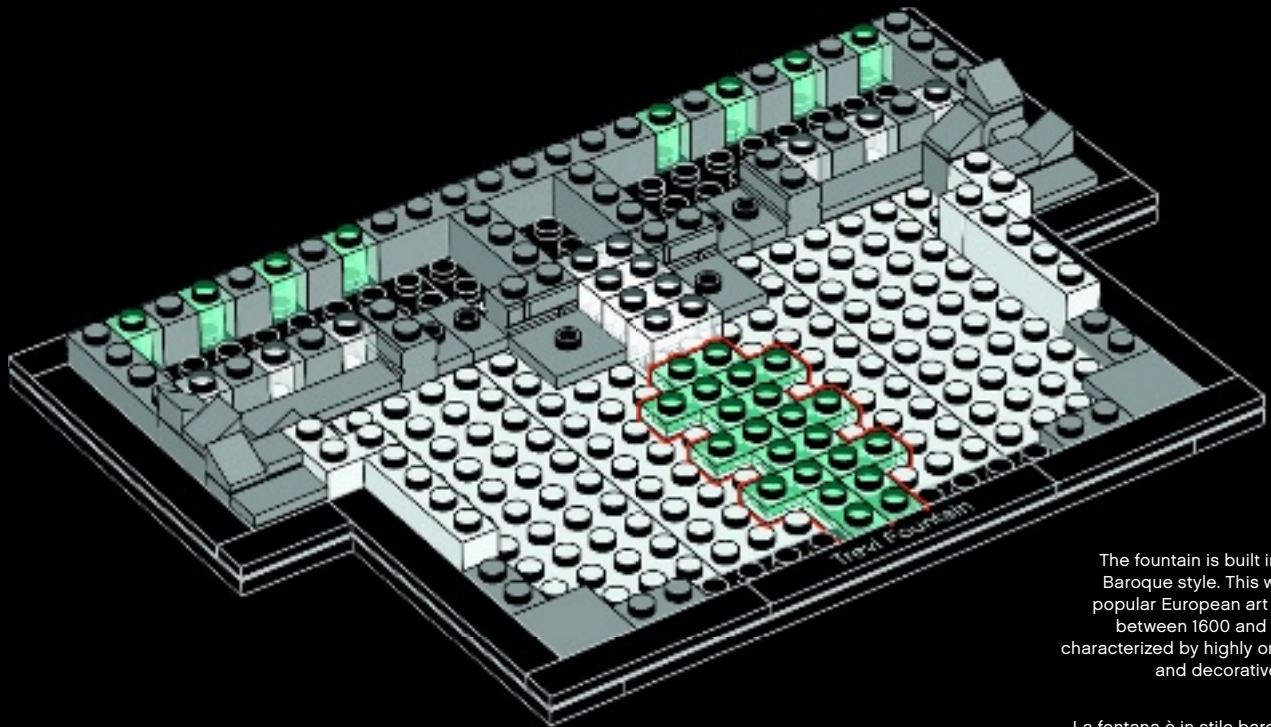

The fountain is built in the Baroque style. This was a popular European art form between 1600 and 1750, characterized by highly ornate and decorative art.

La fontana è in stile barocco, uno stile architettonico molto popolare in Europa fra il 1600 e il 1750, caratterizzata da forme altamente ornate e complesse.

© shutterstock





20x

26

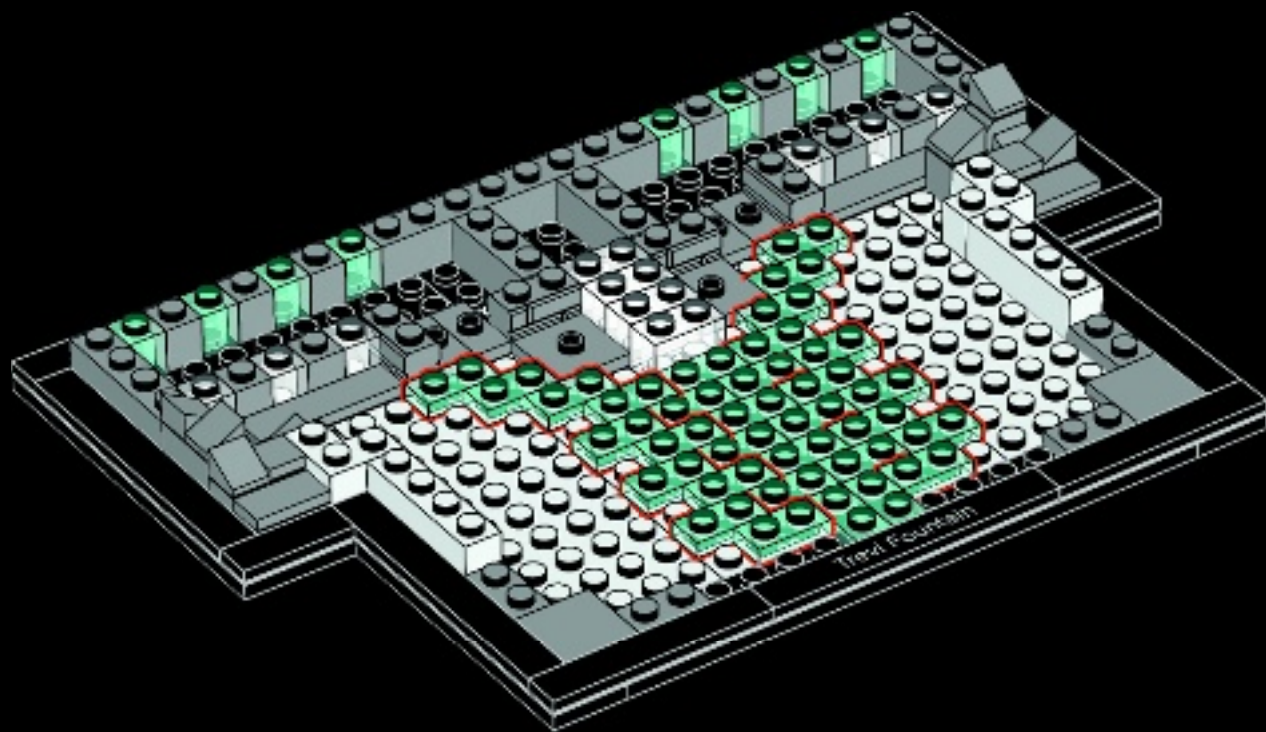



20x

27

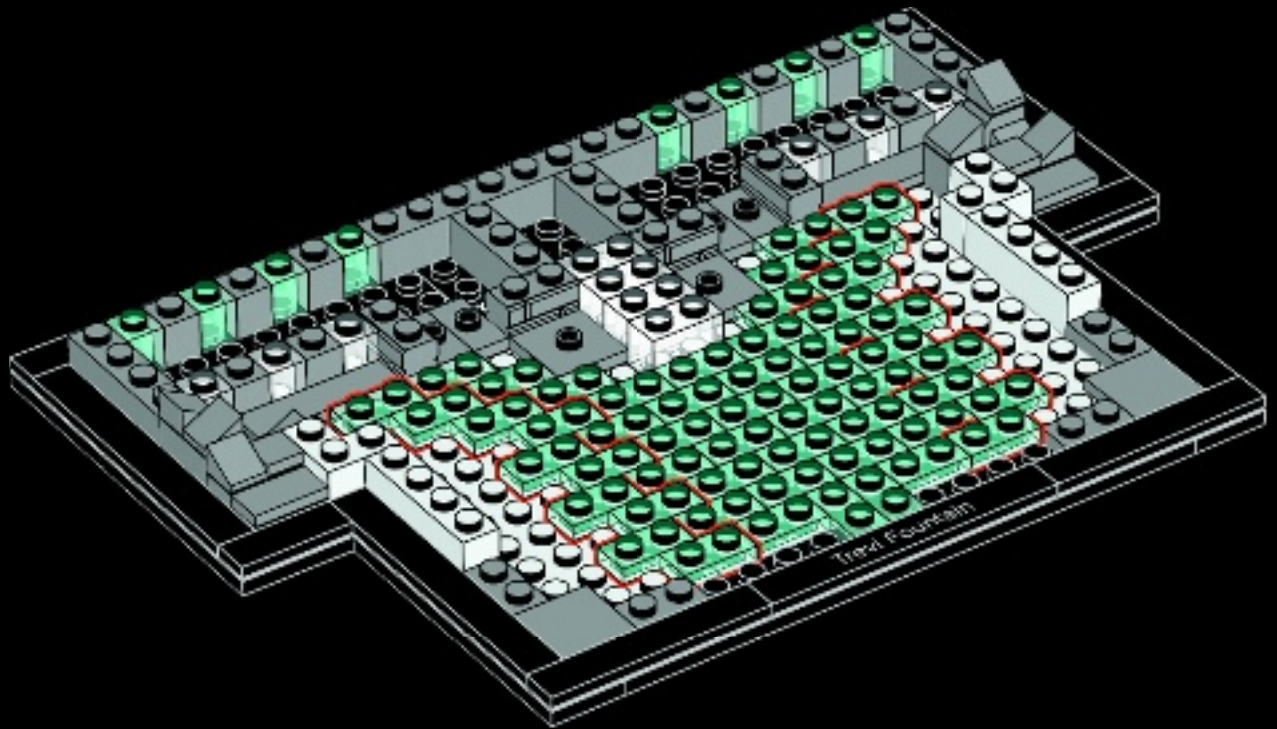



18x

28

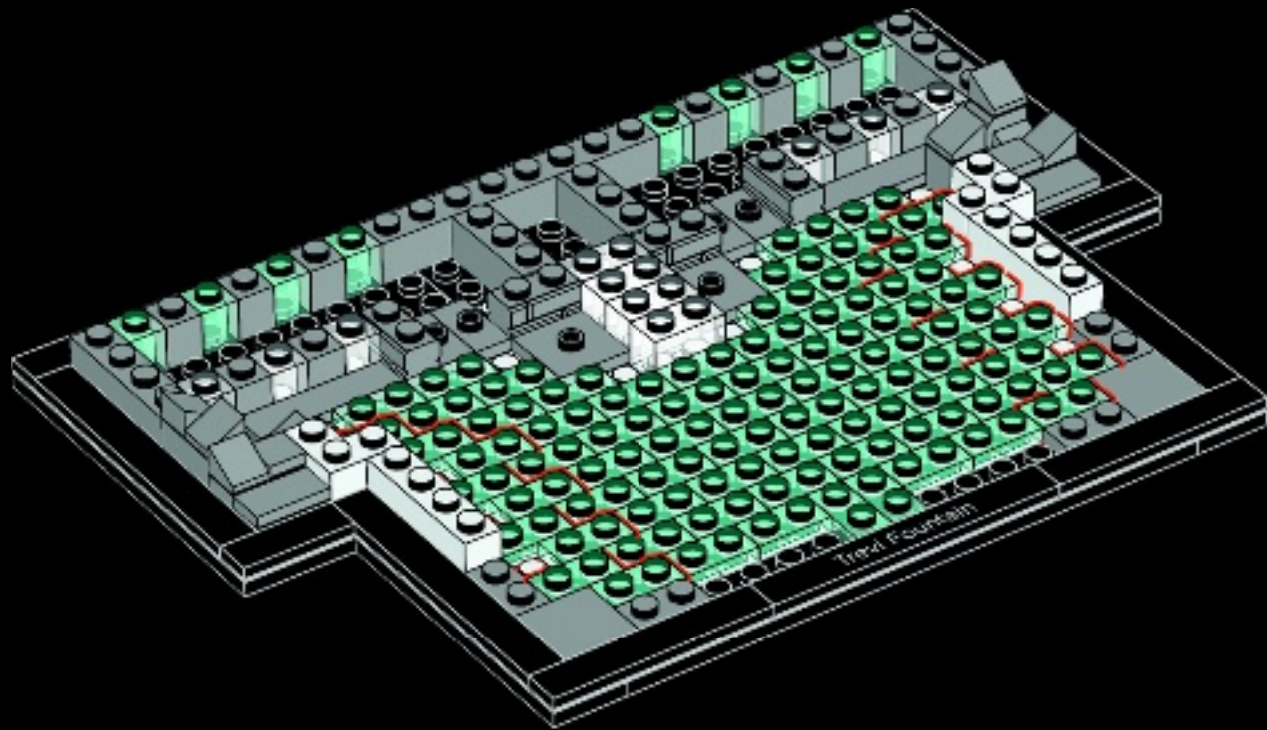



12x

29

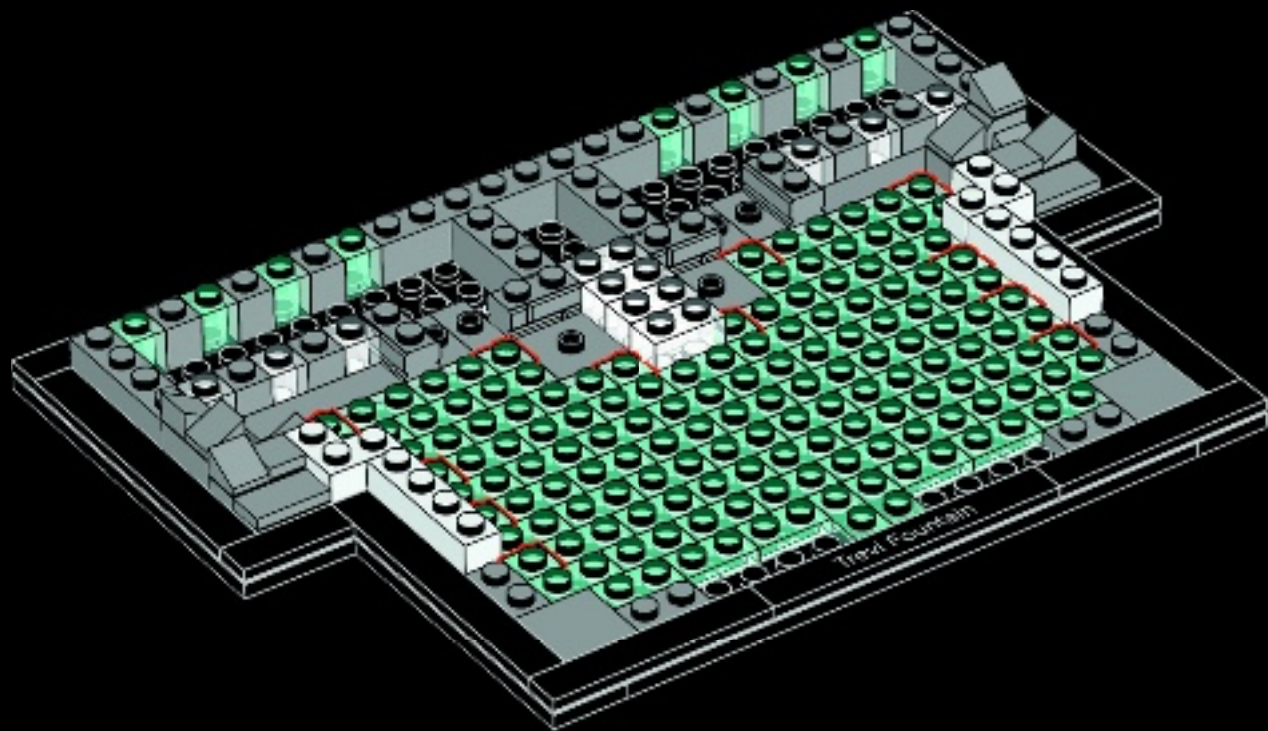



30

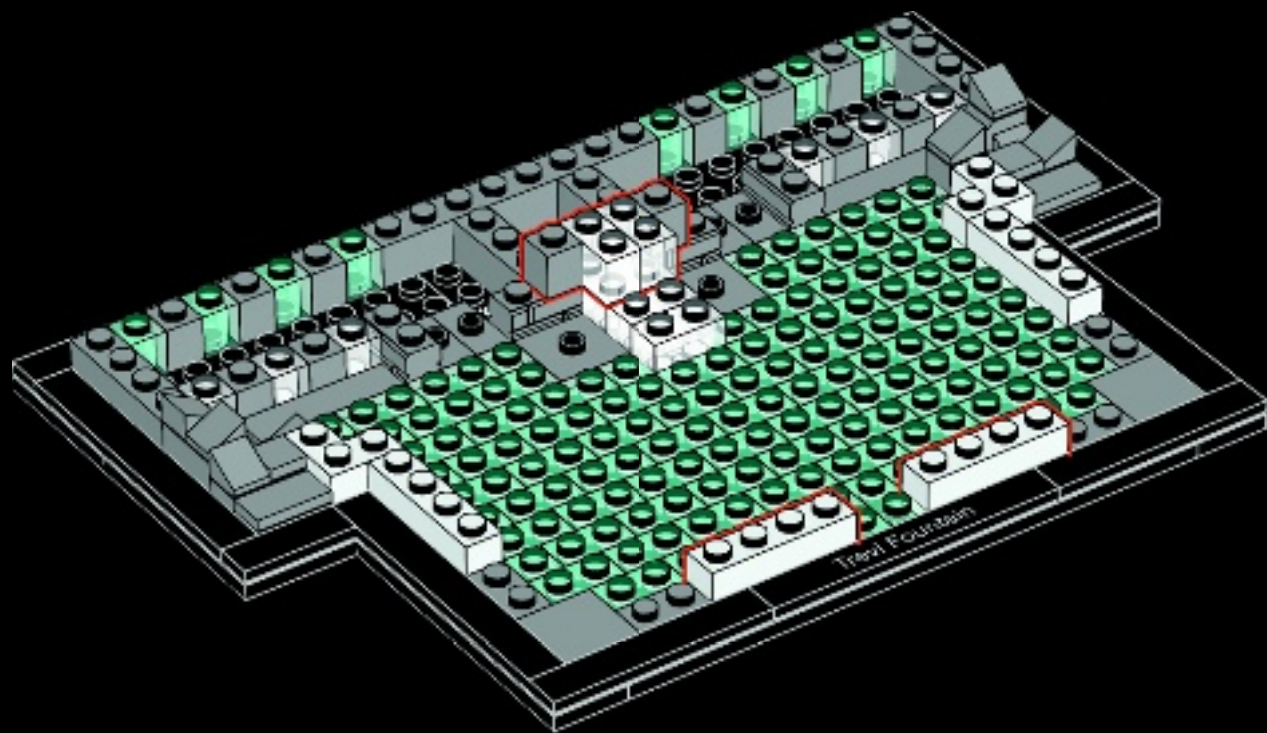



8x



2x

31

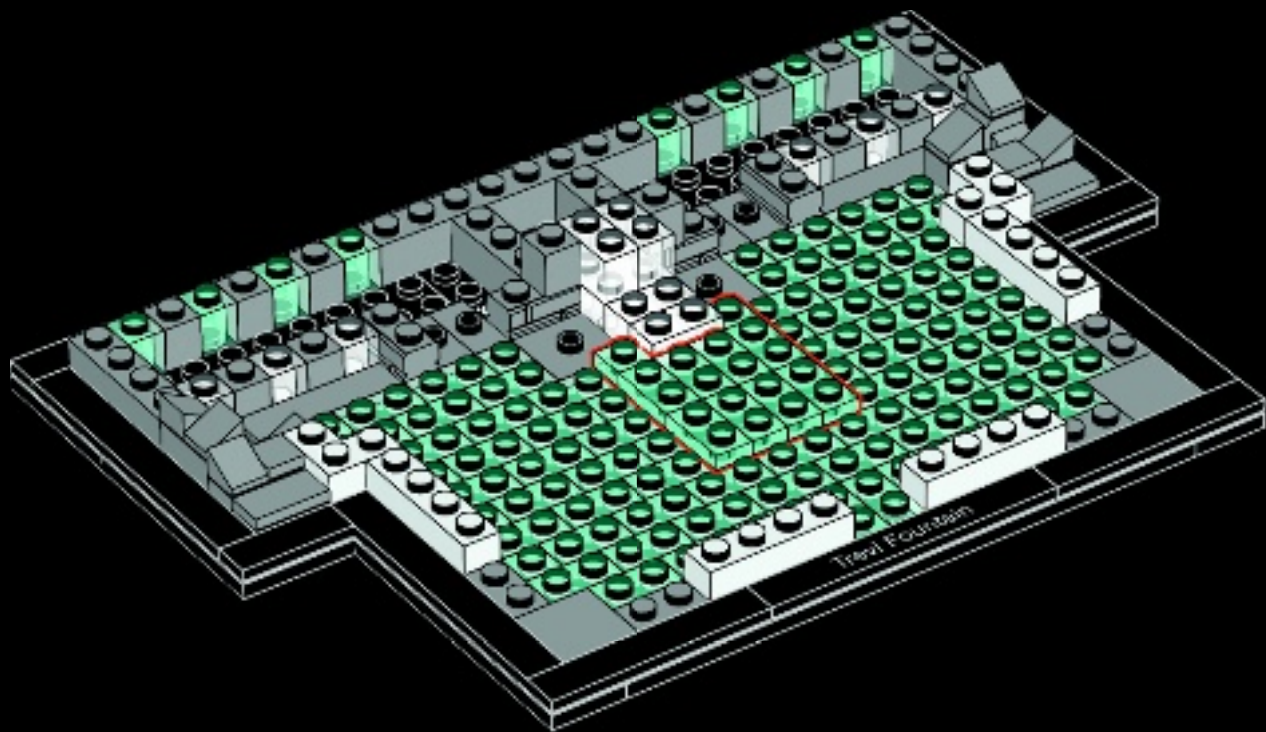



5x

32

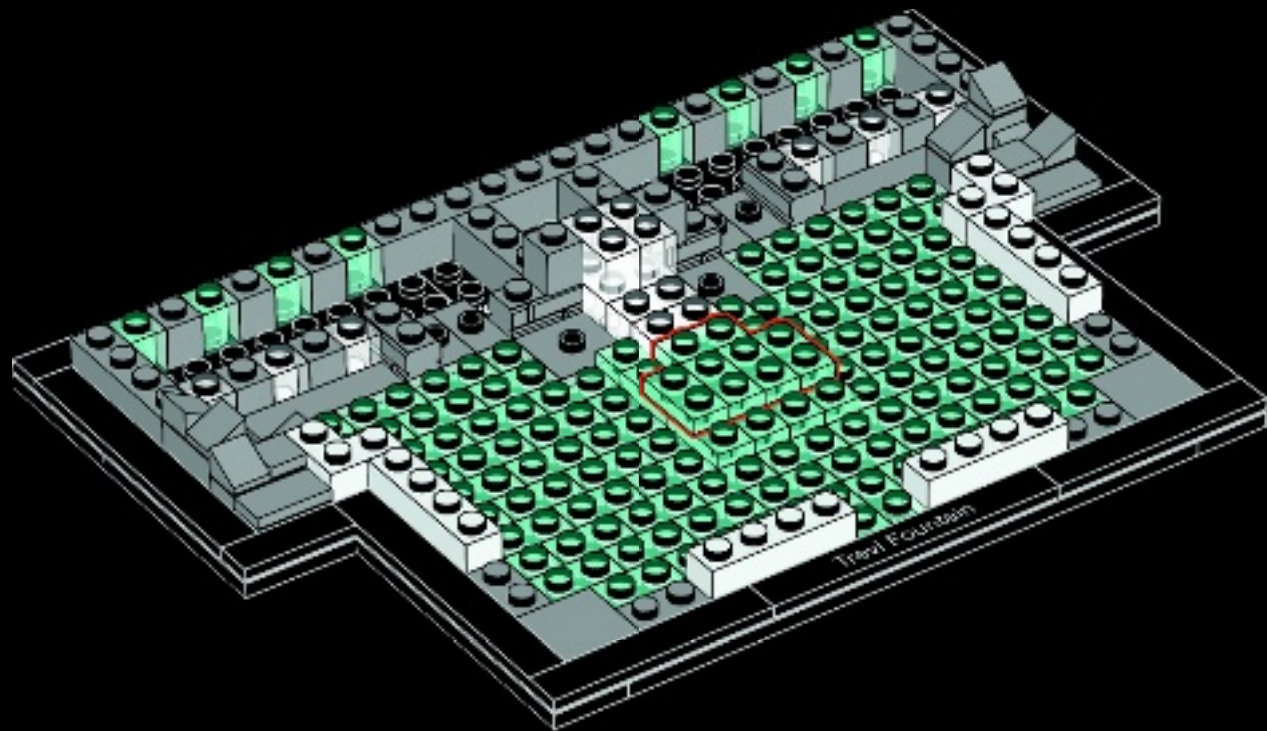



3x



1x

33

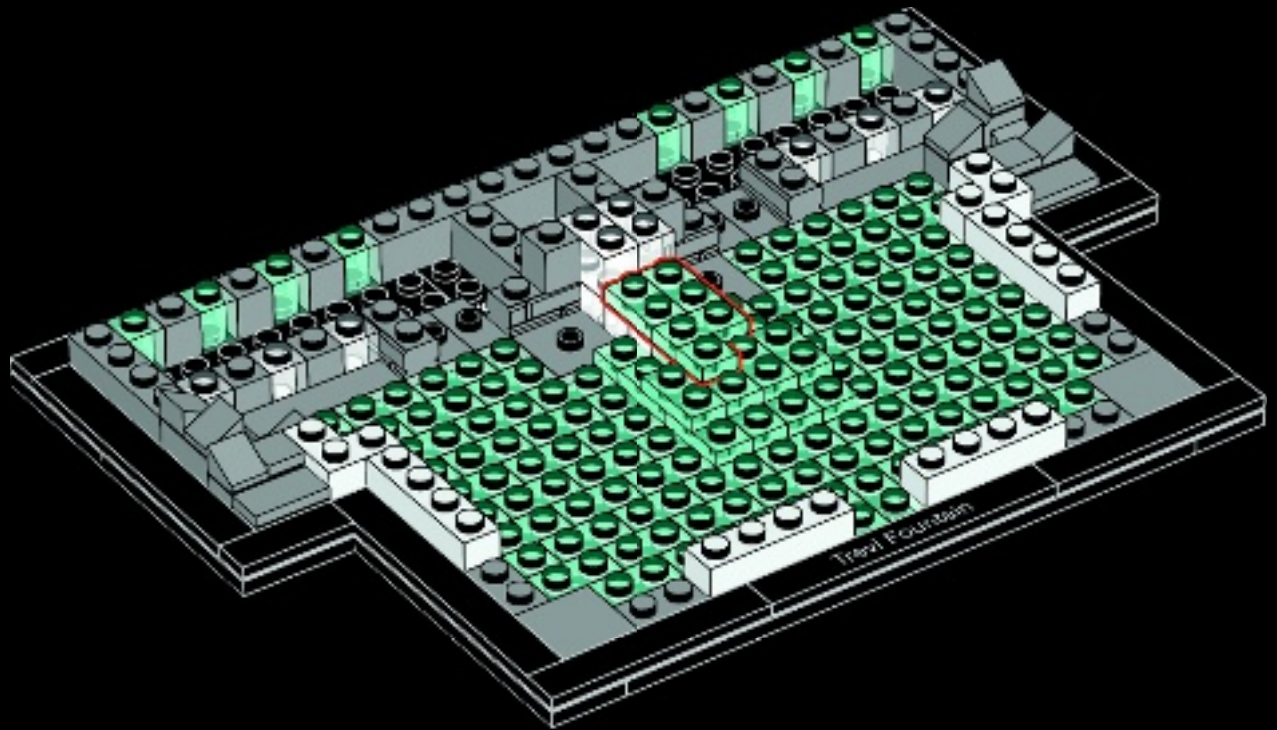



2x

34

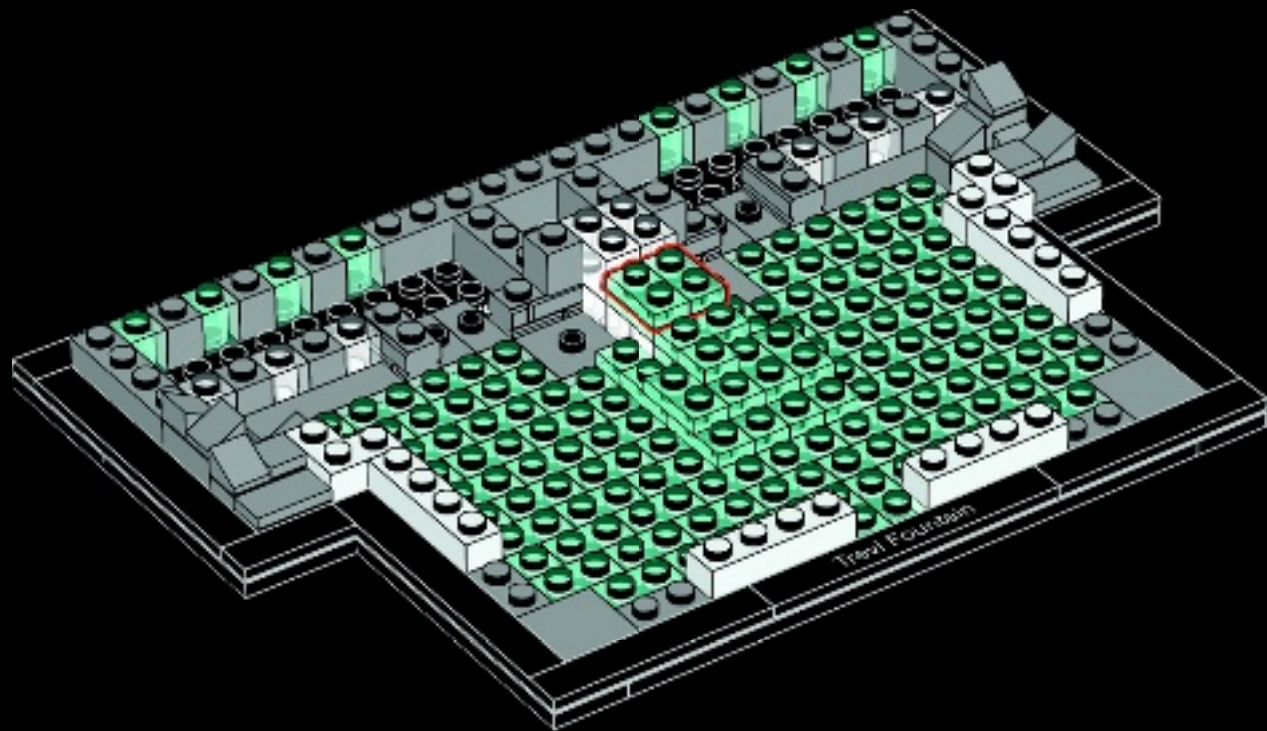



3x

35

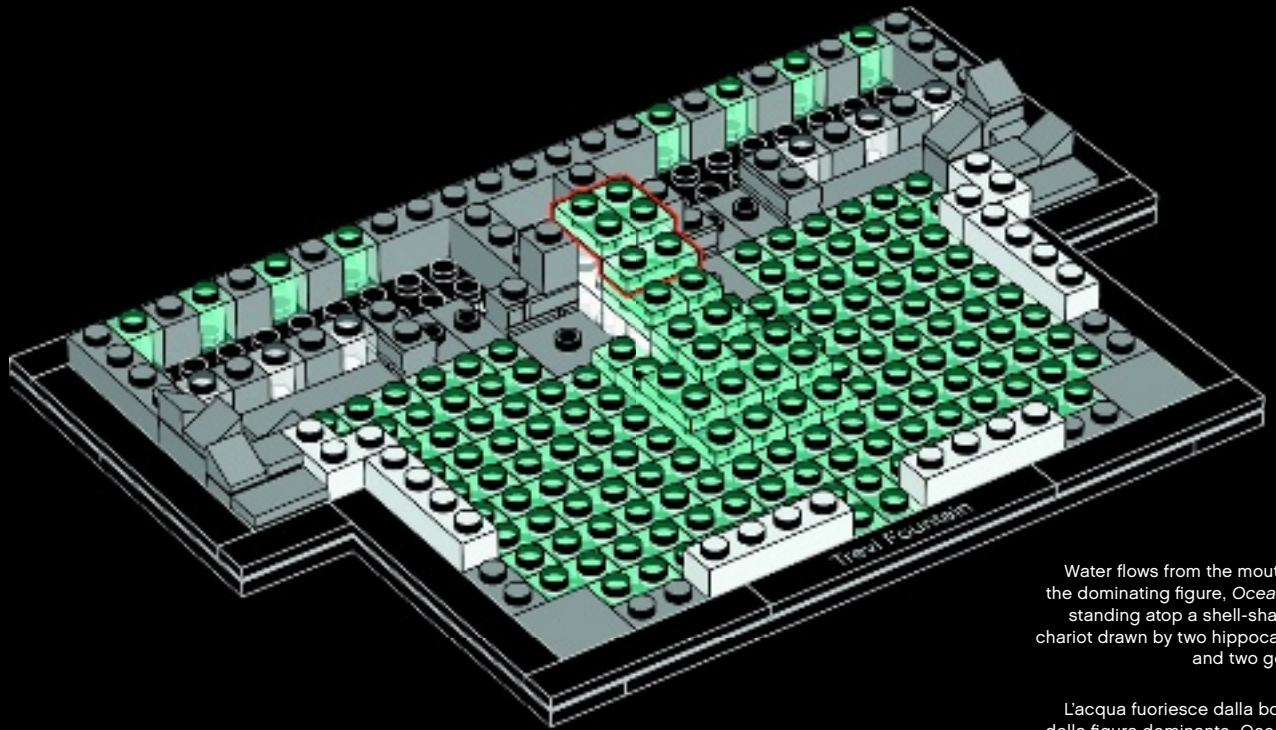

Water flows from the mouth of the dominating figure, *Oceanus*, standing atop a shell-shaped chariot drawn by two hippocampi and two gods.

L'acqua fuoriesce dalla bocca della figura dominante, *Oceano*, sul suo cocchio a forma di conchiglia, trainato da due cavalli alati e due tritoni.



© shutterstock



5x



2x

36

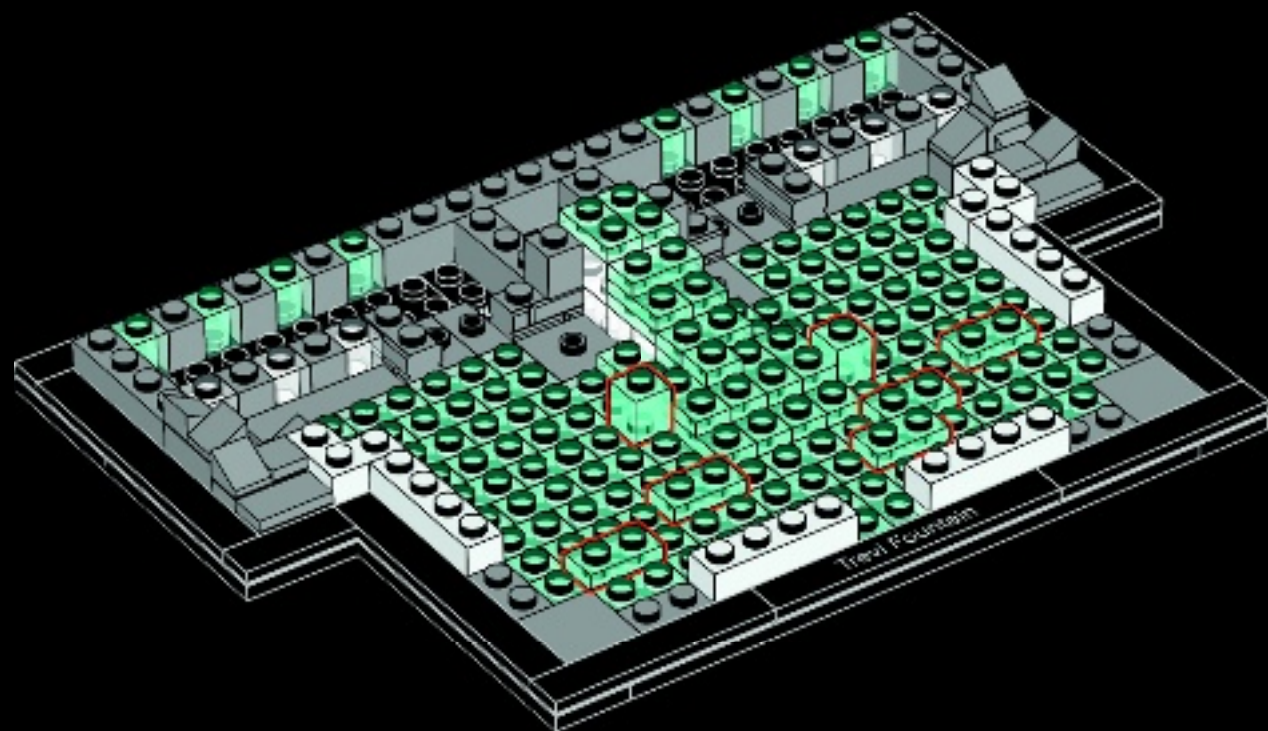



37

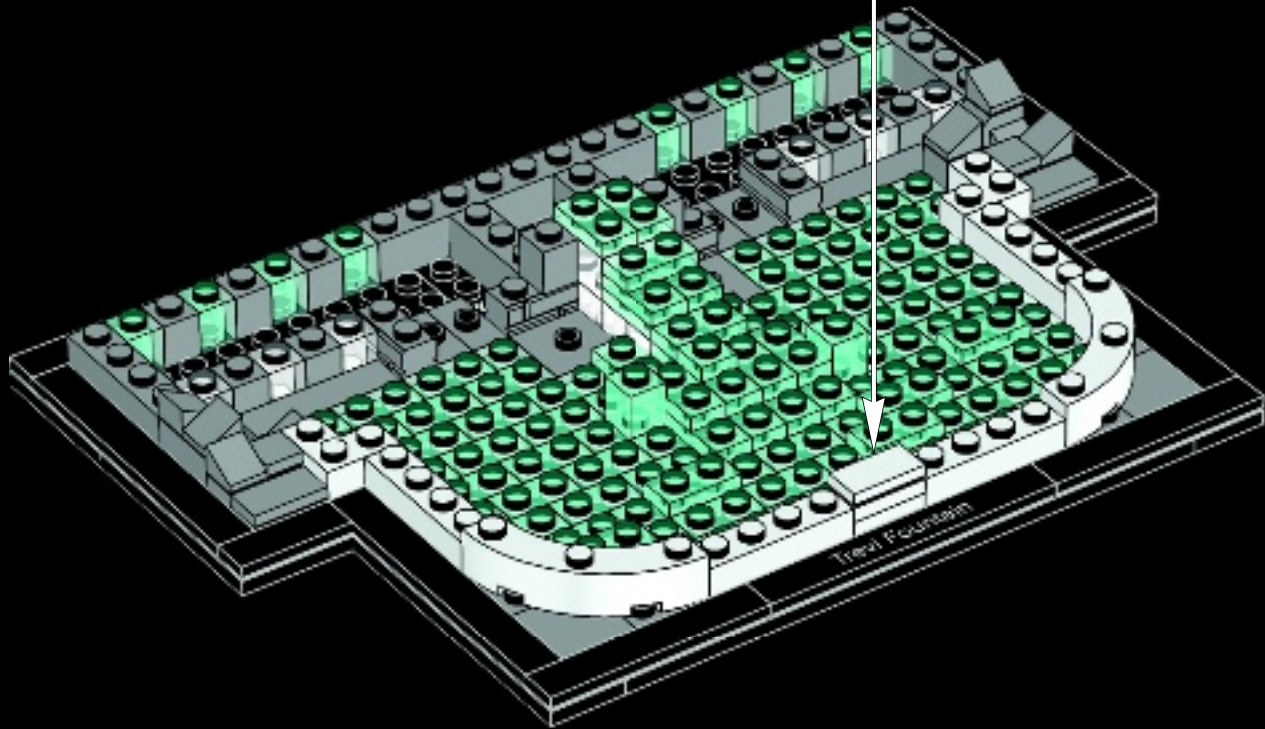
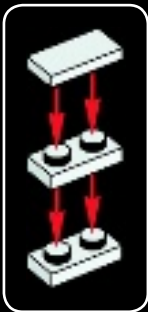

Trest Fountain



10x



2x

38

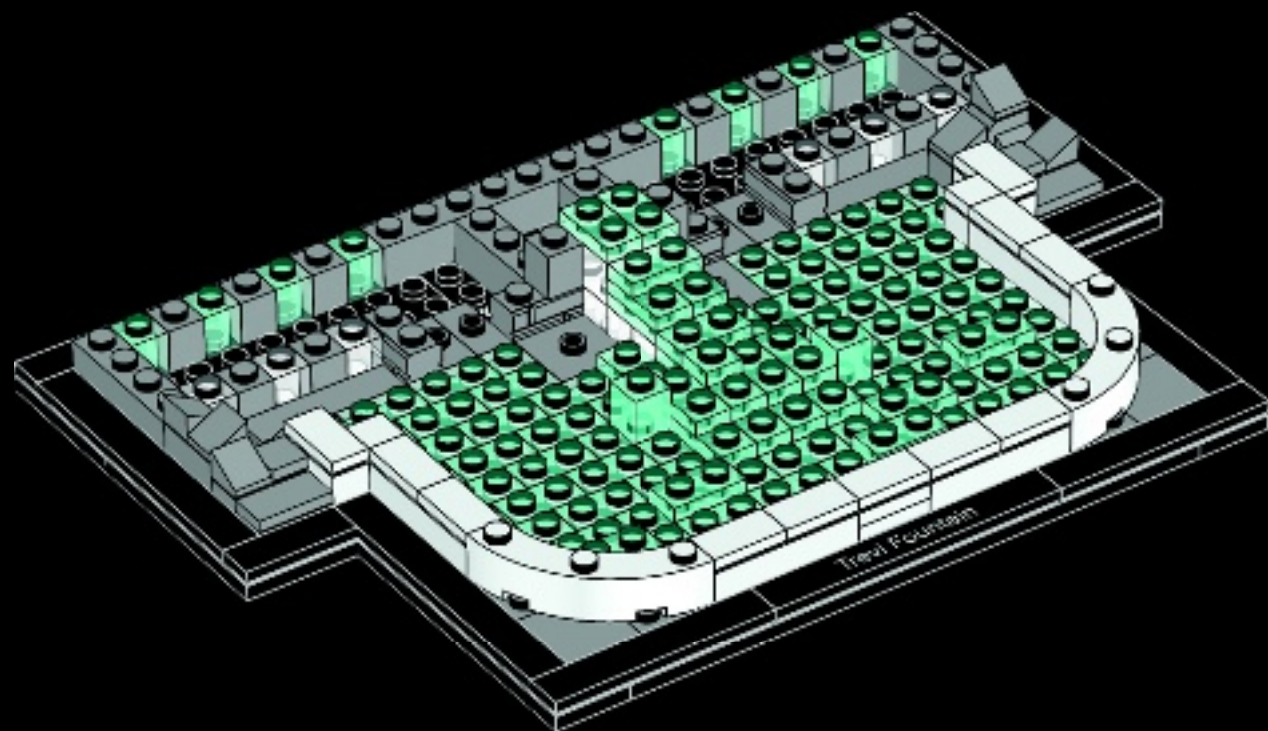

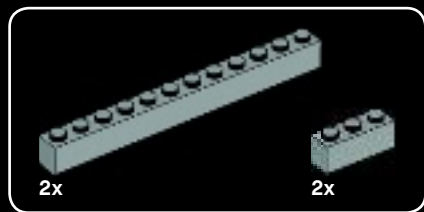

39

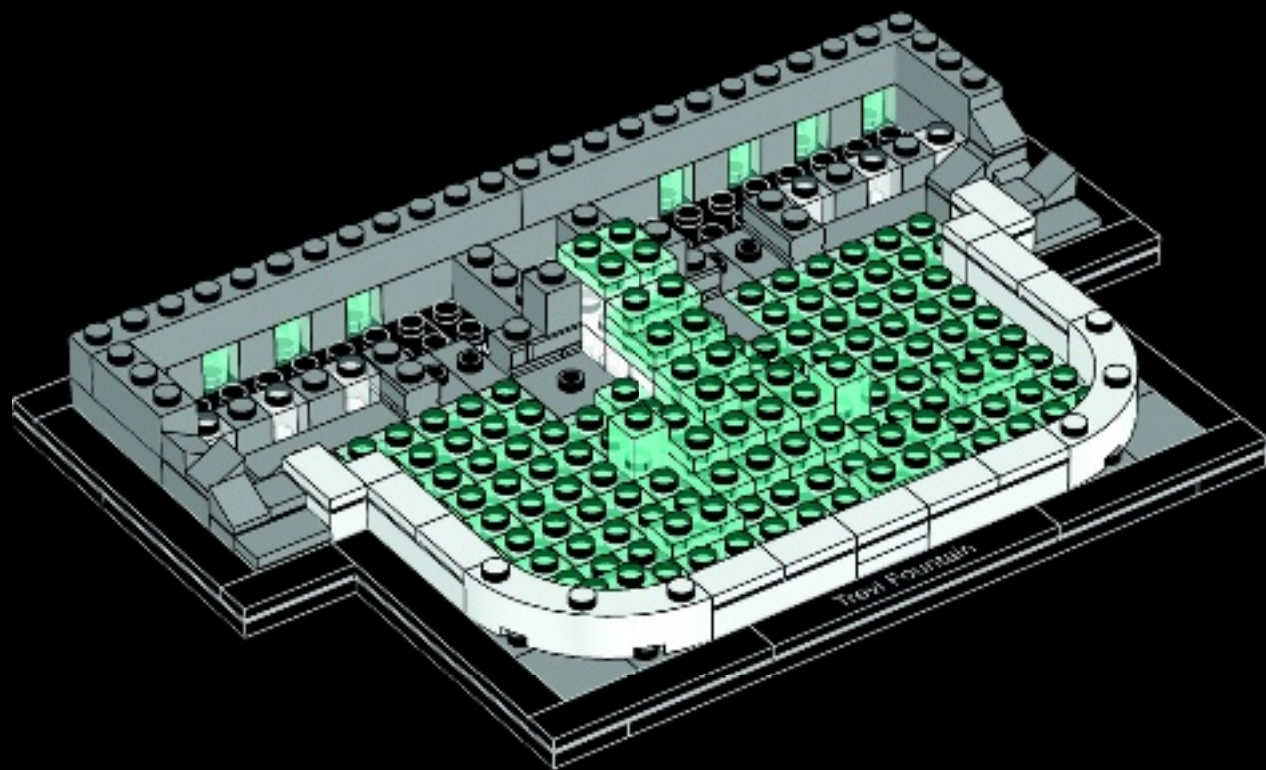



2x



6x

40

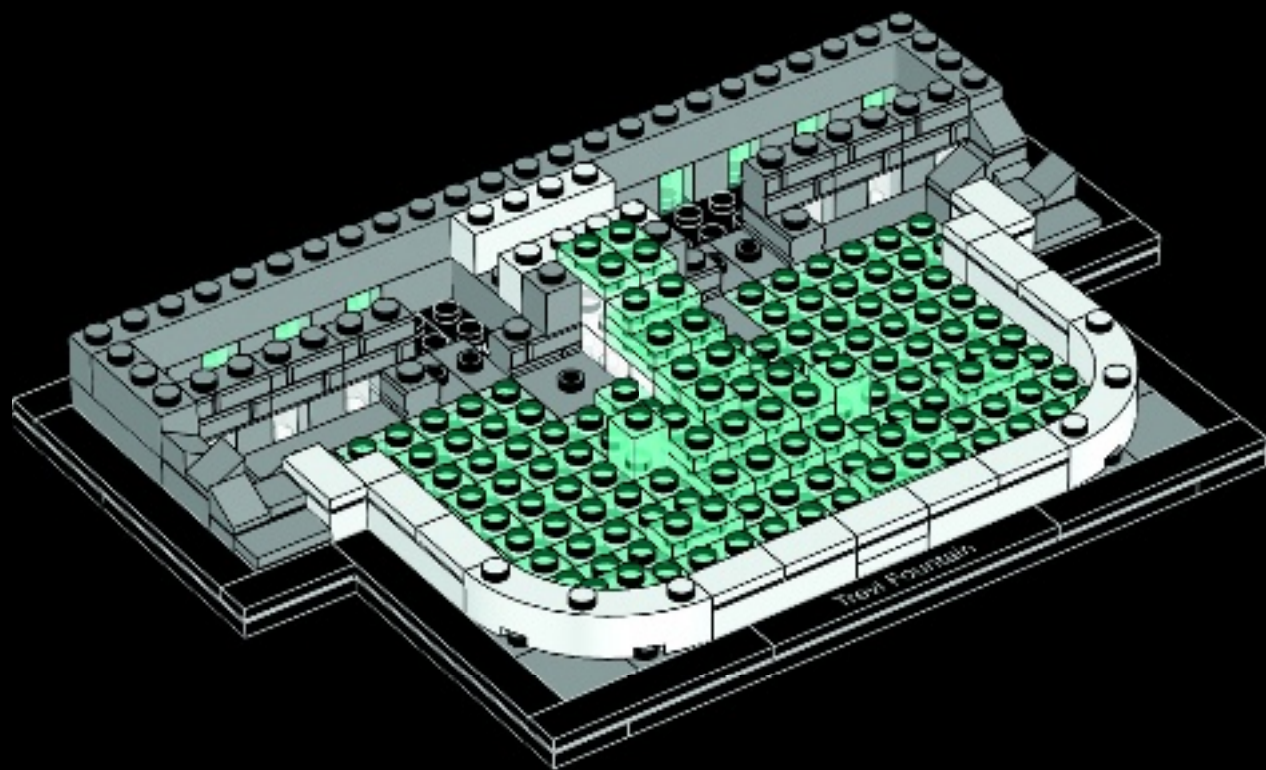



10x



8x

41

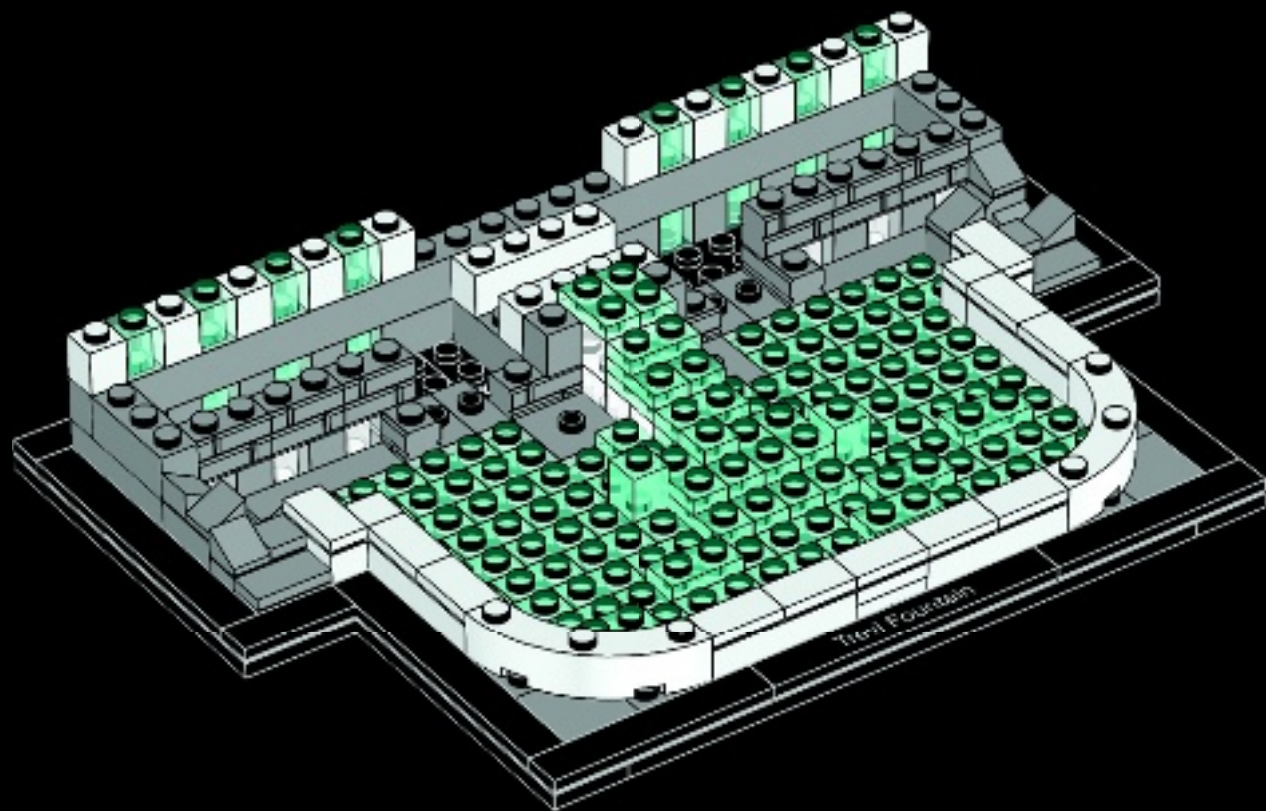

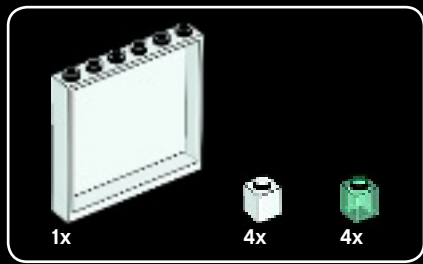

42

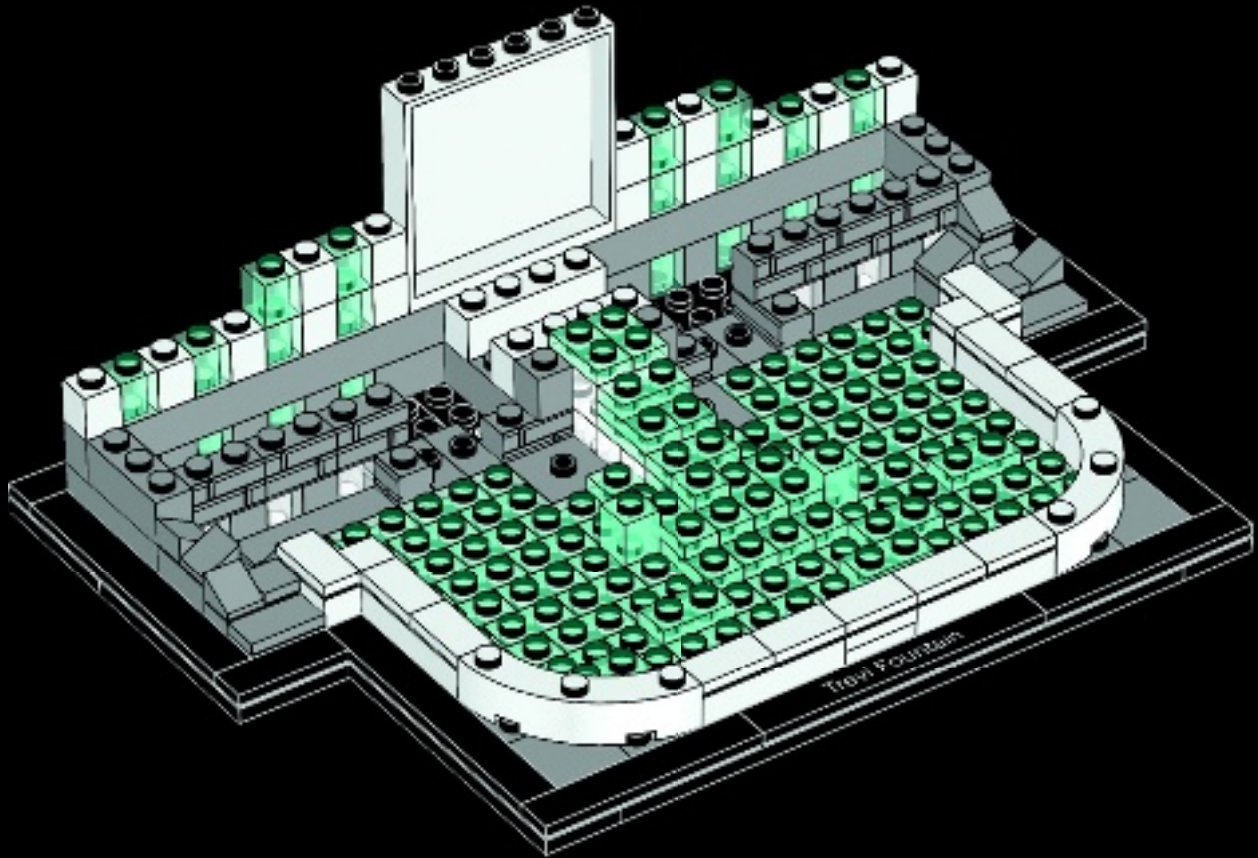



4x



2x



4x

43

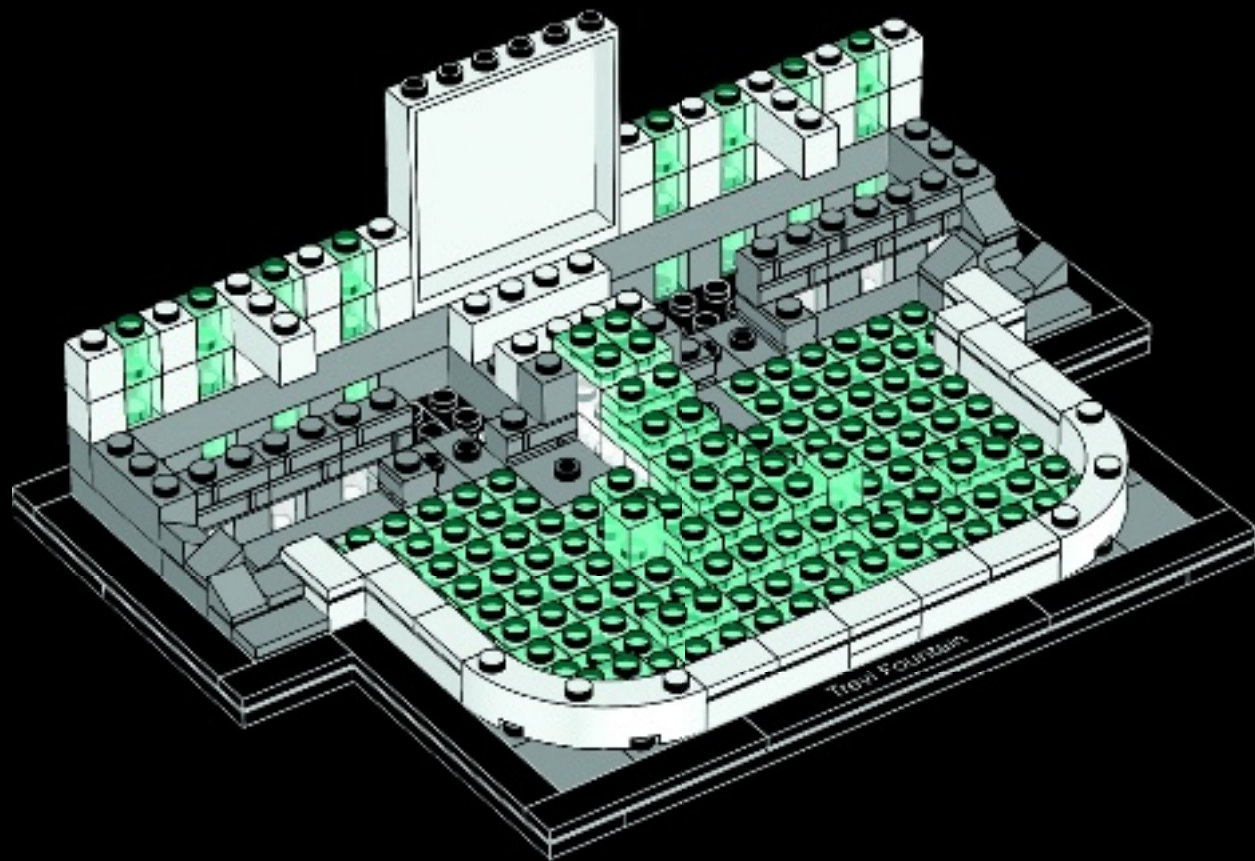

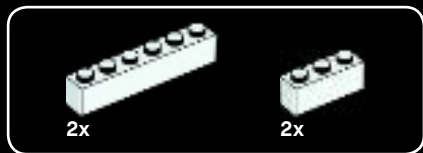

44

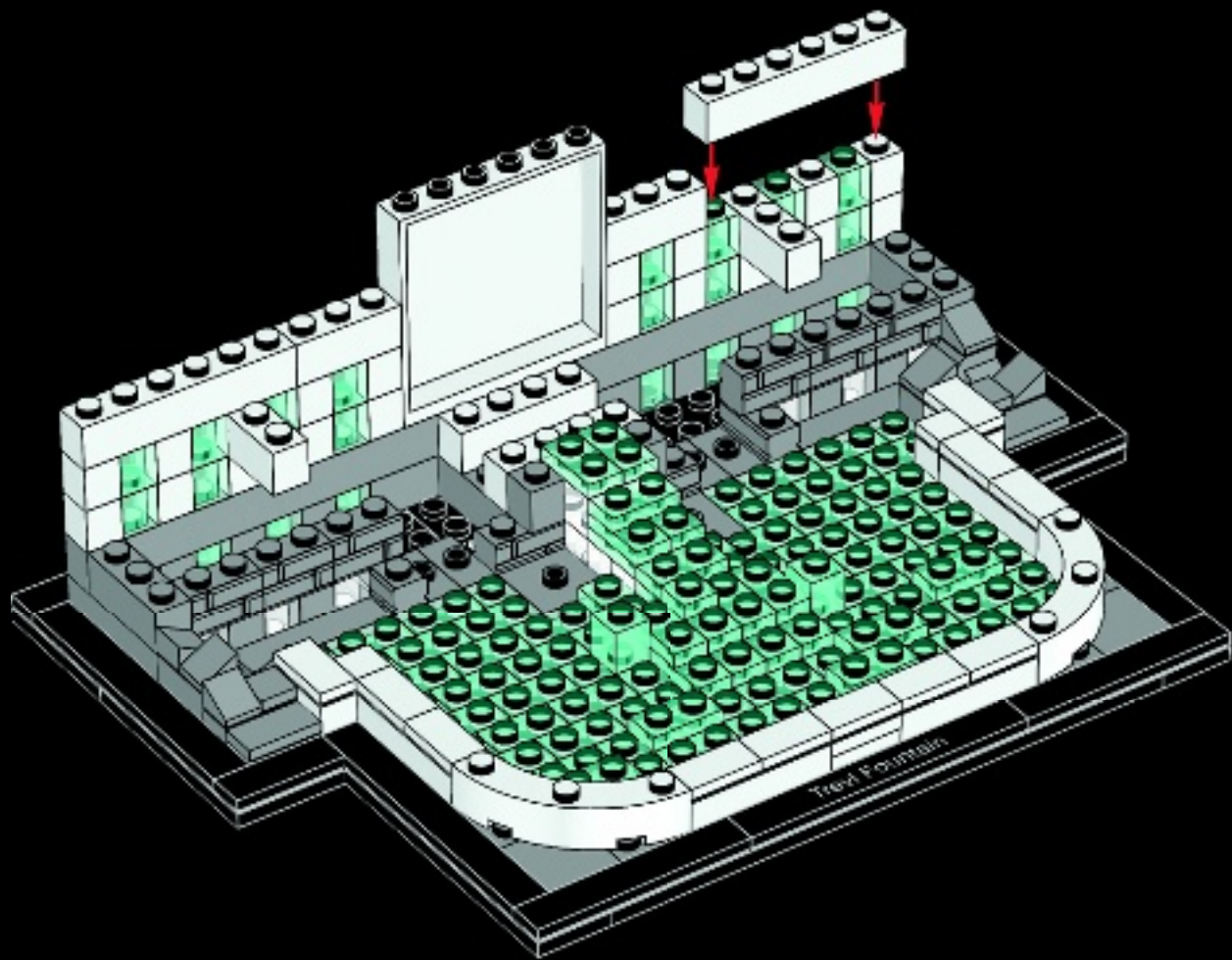



10x



8x

45

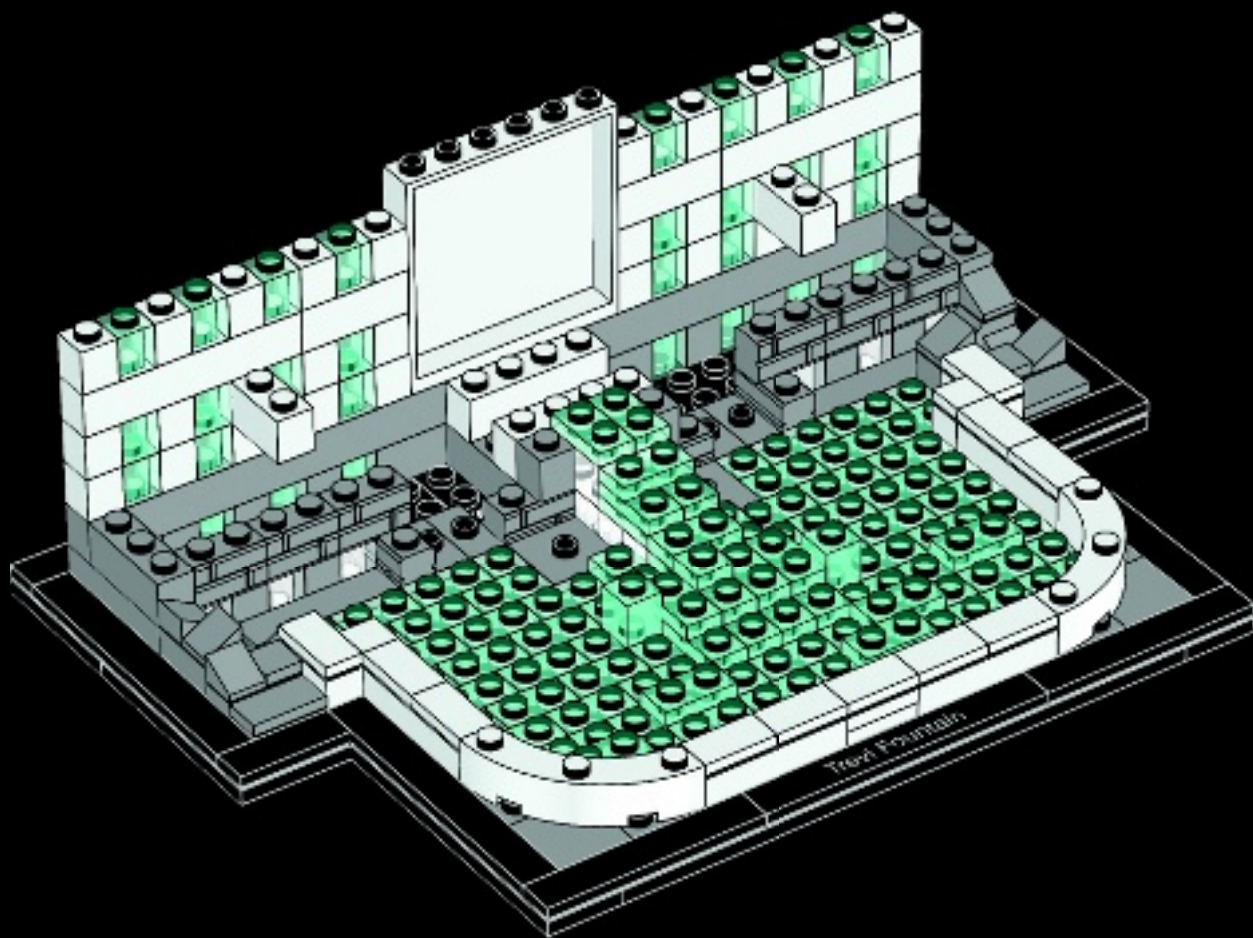

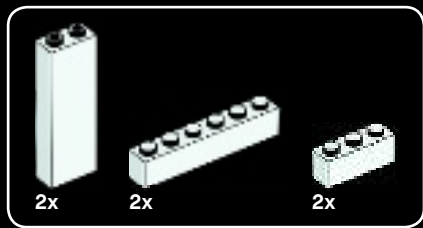

46

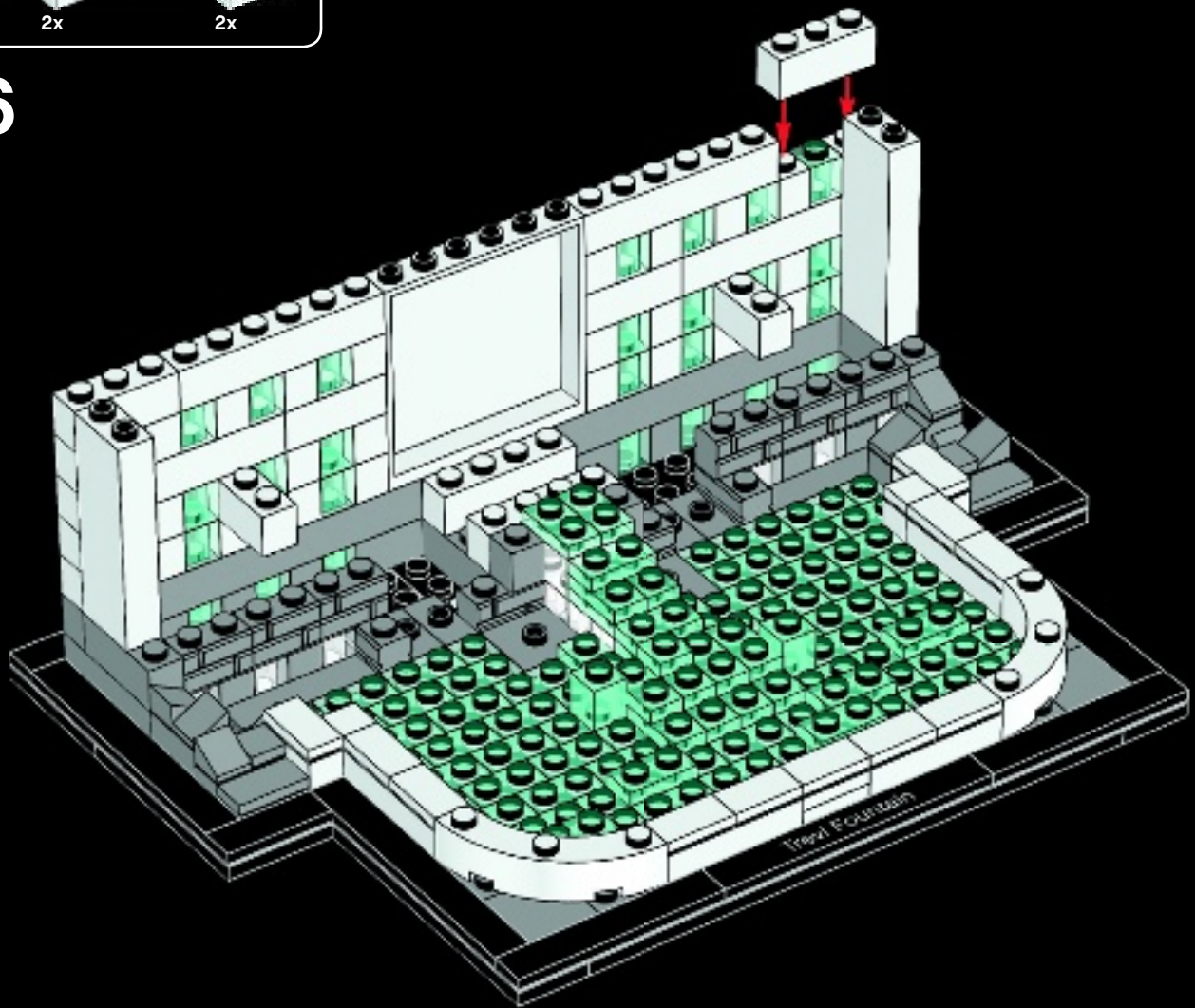

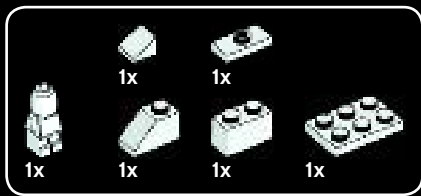

47

1



2



3

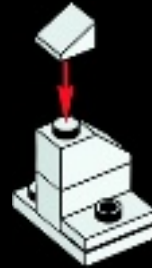

4



The fountain is mostly built of travertine stone. This popular building material came from a quarry located 22 miles (35 km) to the east of Rome.

La fontana è stata realizzata per la maggior parte in travertino. Questo popolare materiale edile proveniva da una cava situata 35 km a est di Roma.



© shutterstock

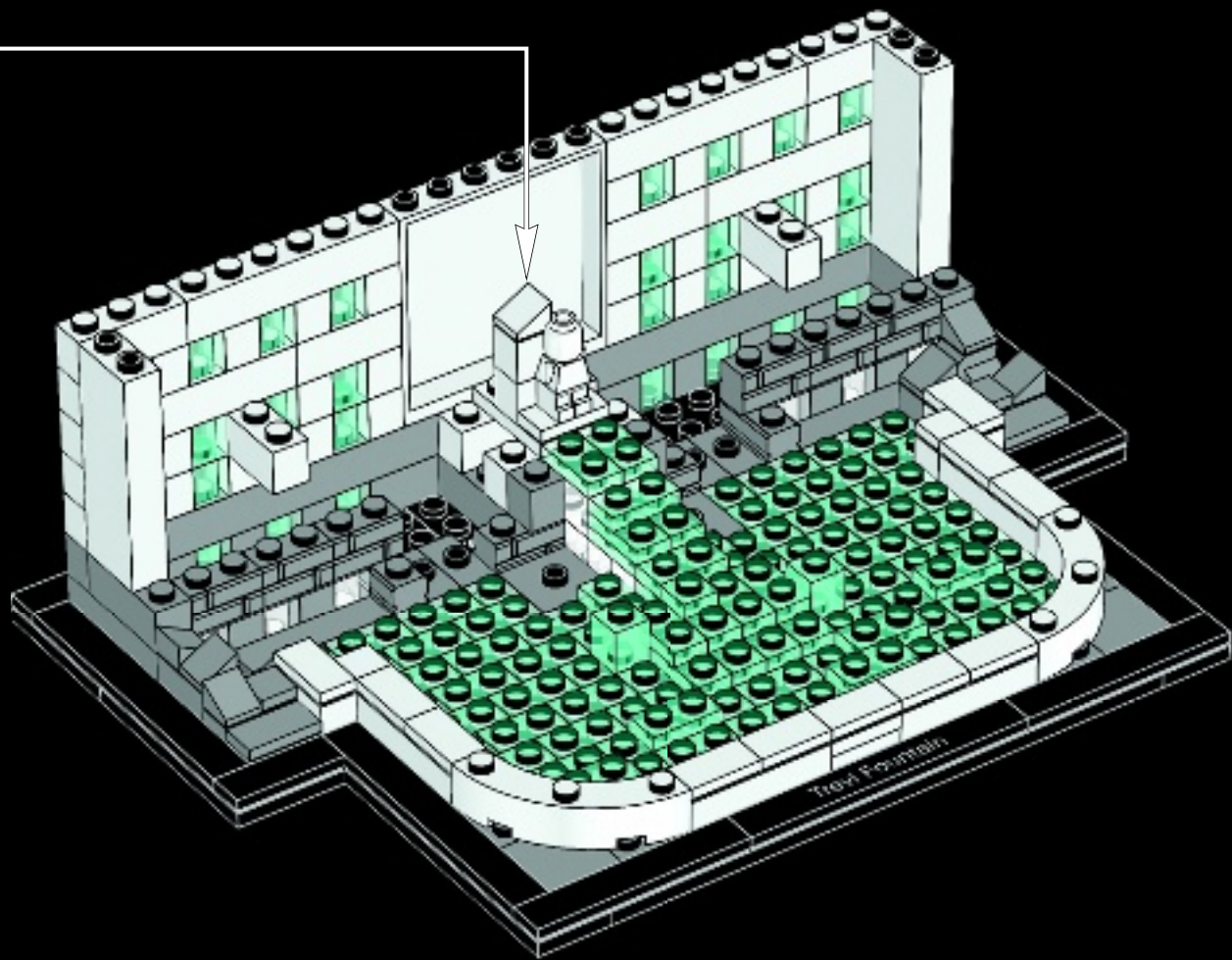



2x



2x



2x

48

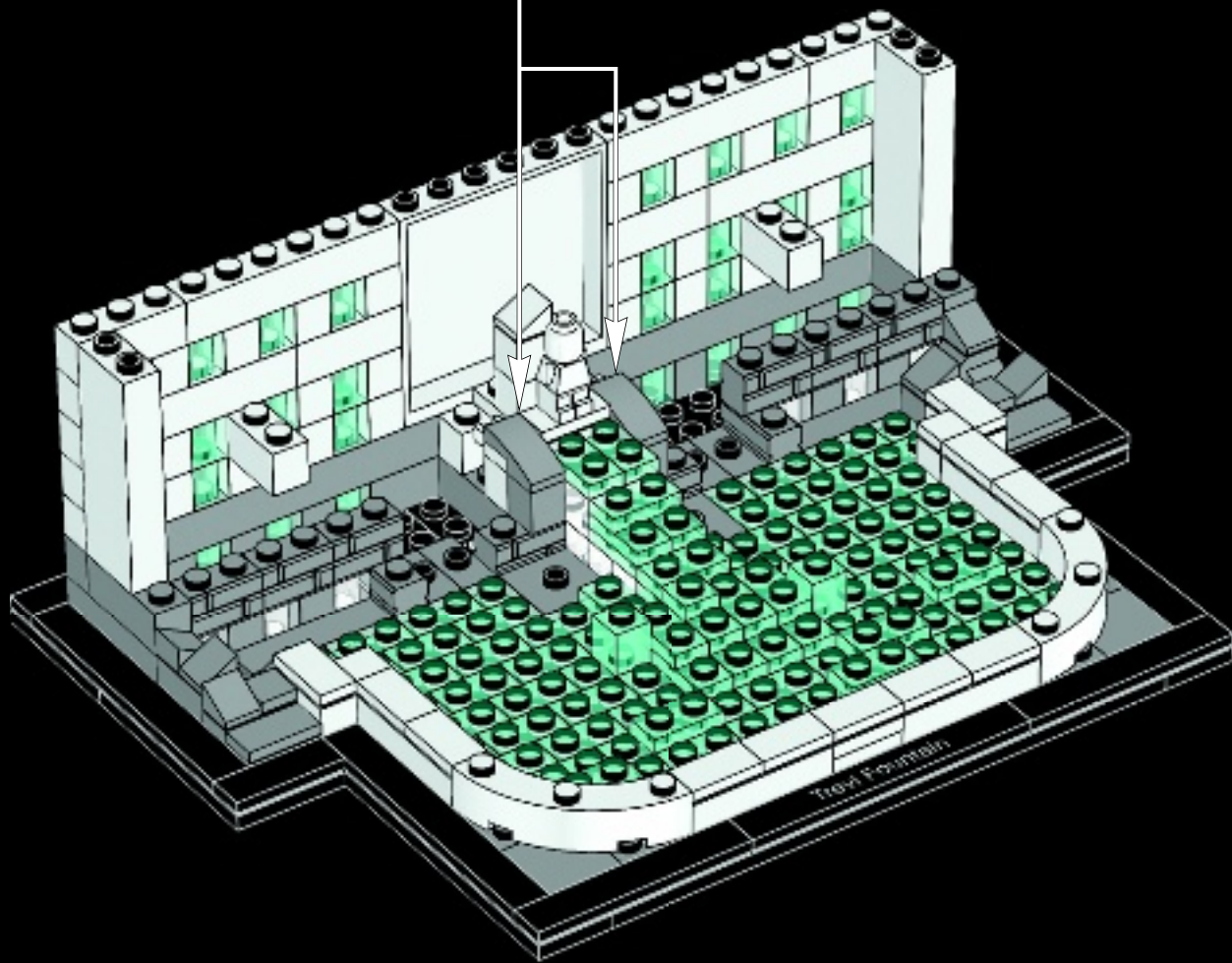



2x

49

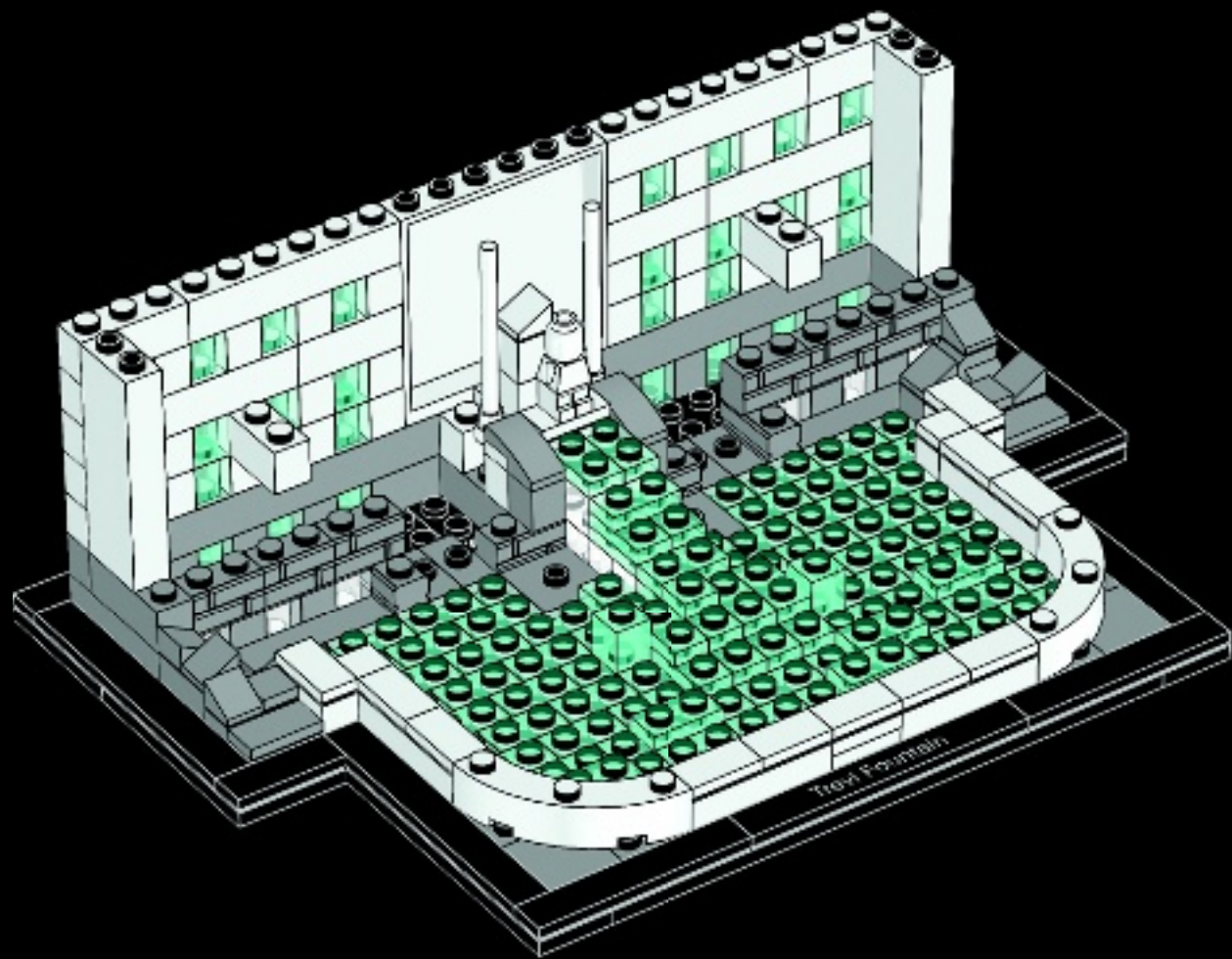



2x

50

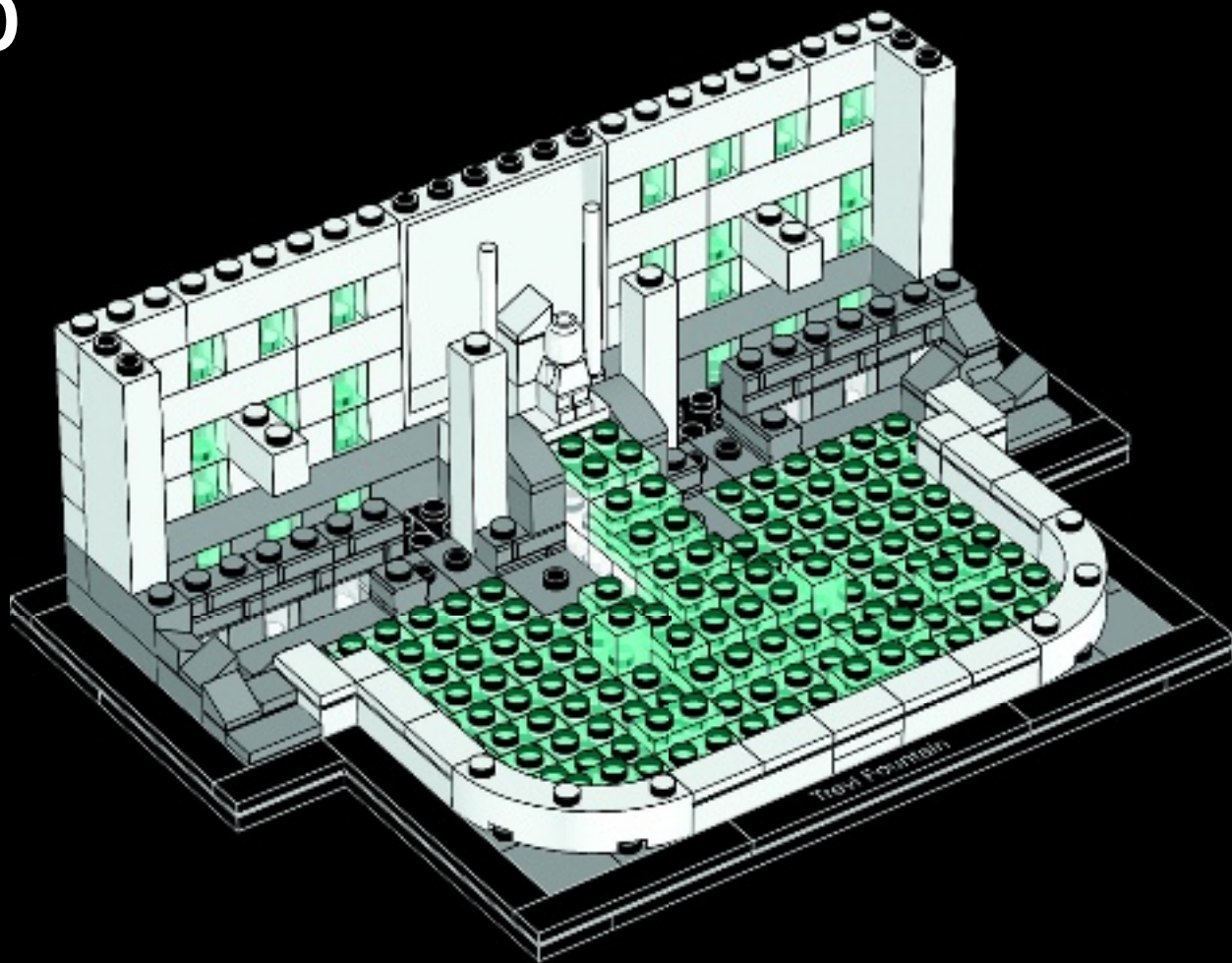



51

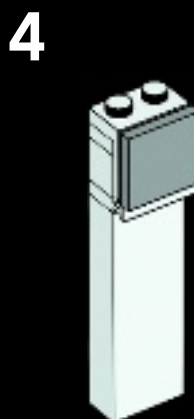
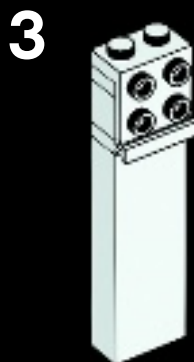
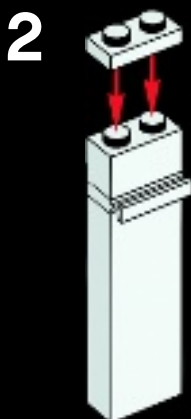
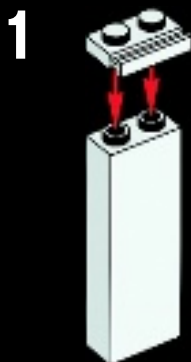

2x

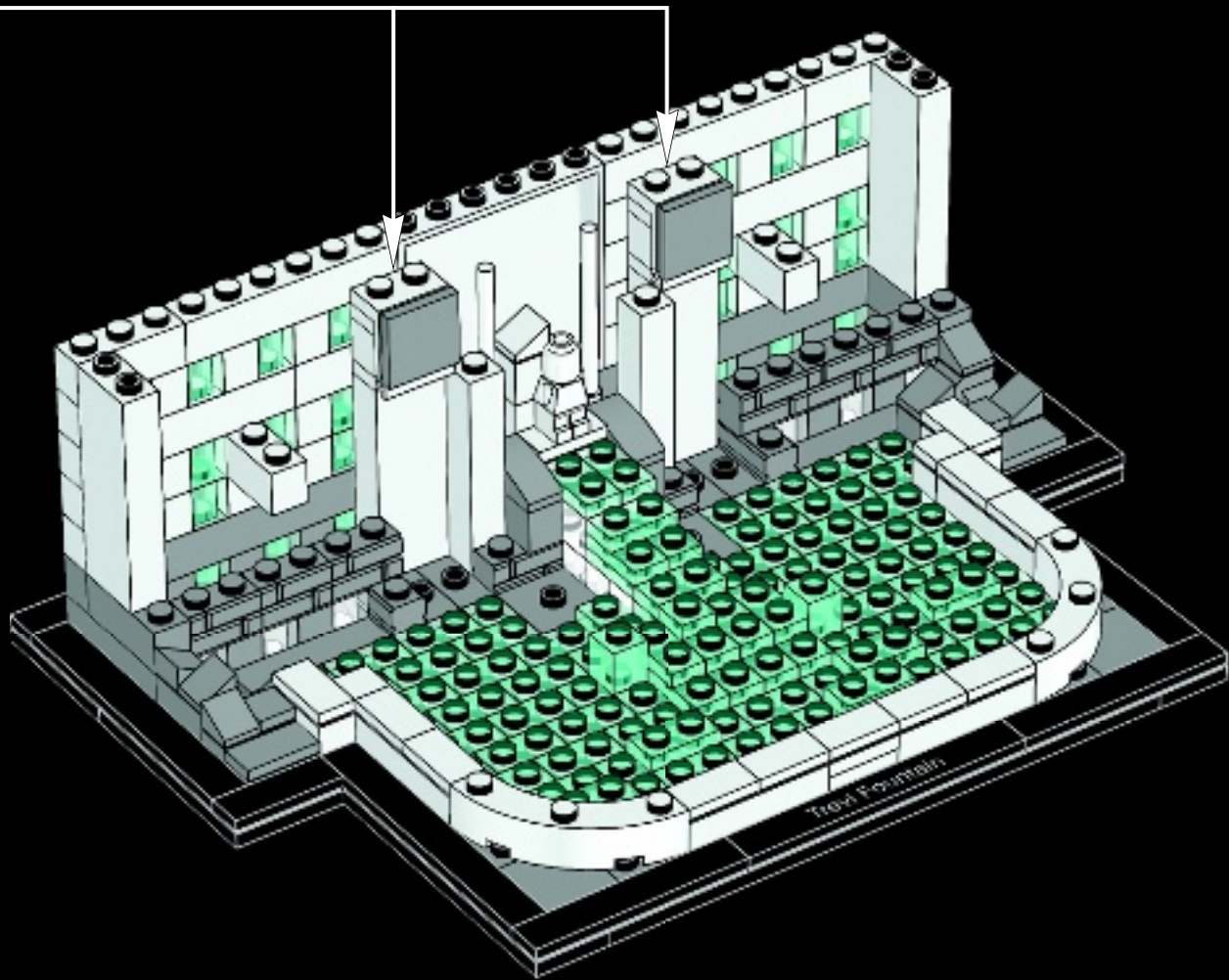



52

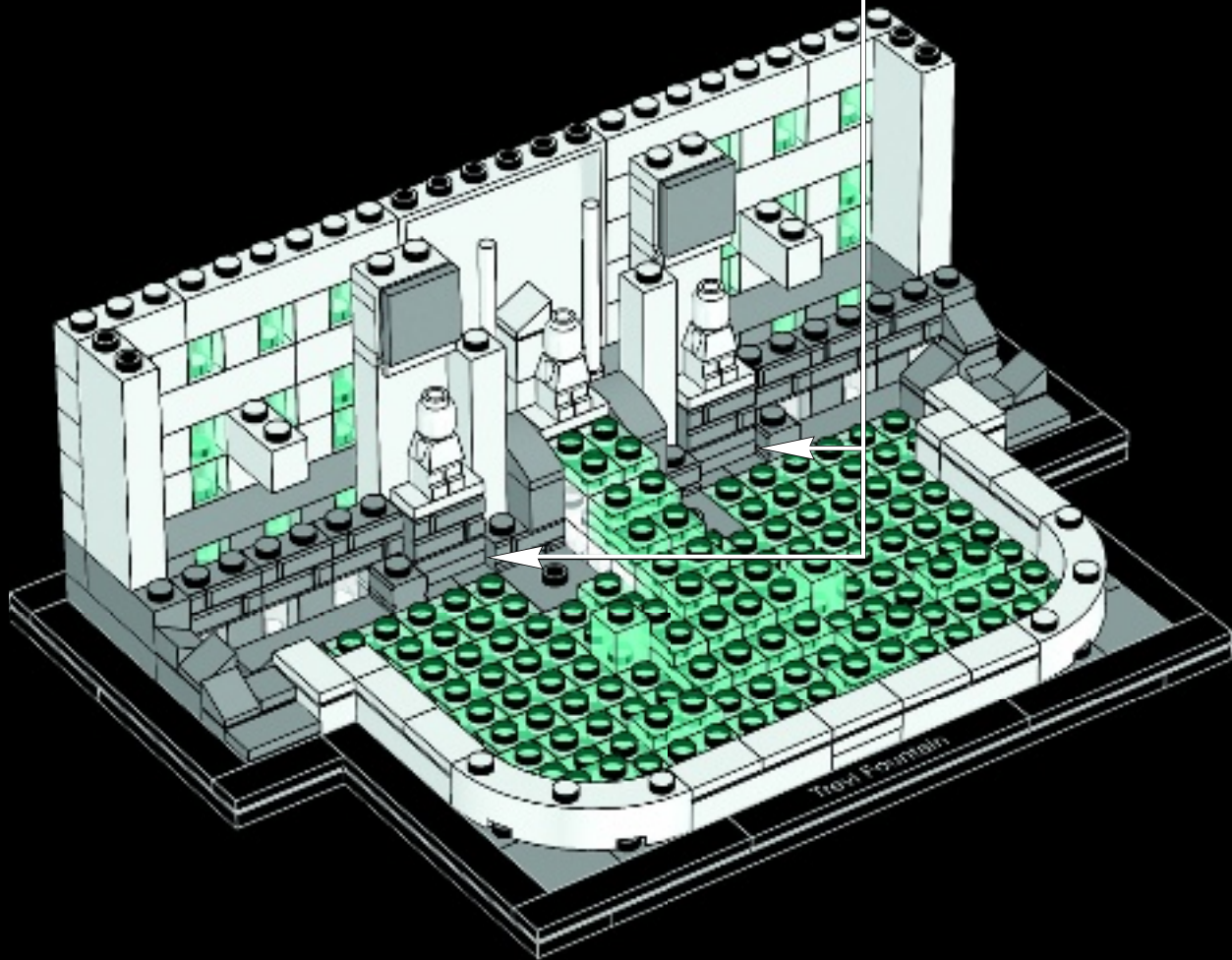
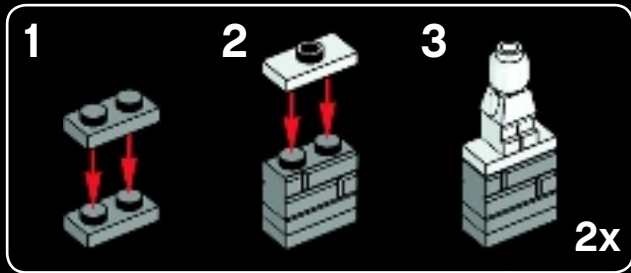

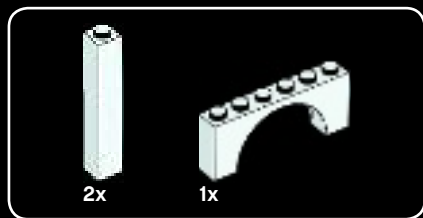

53

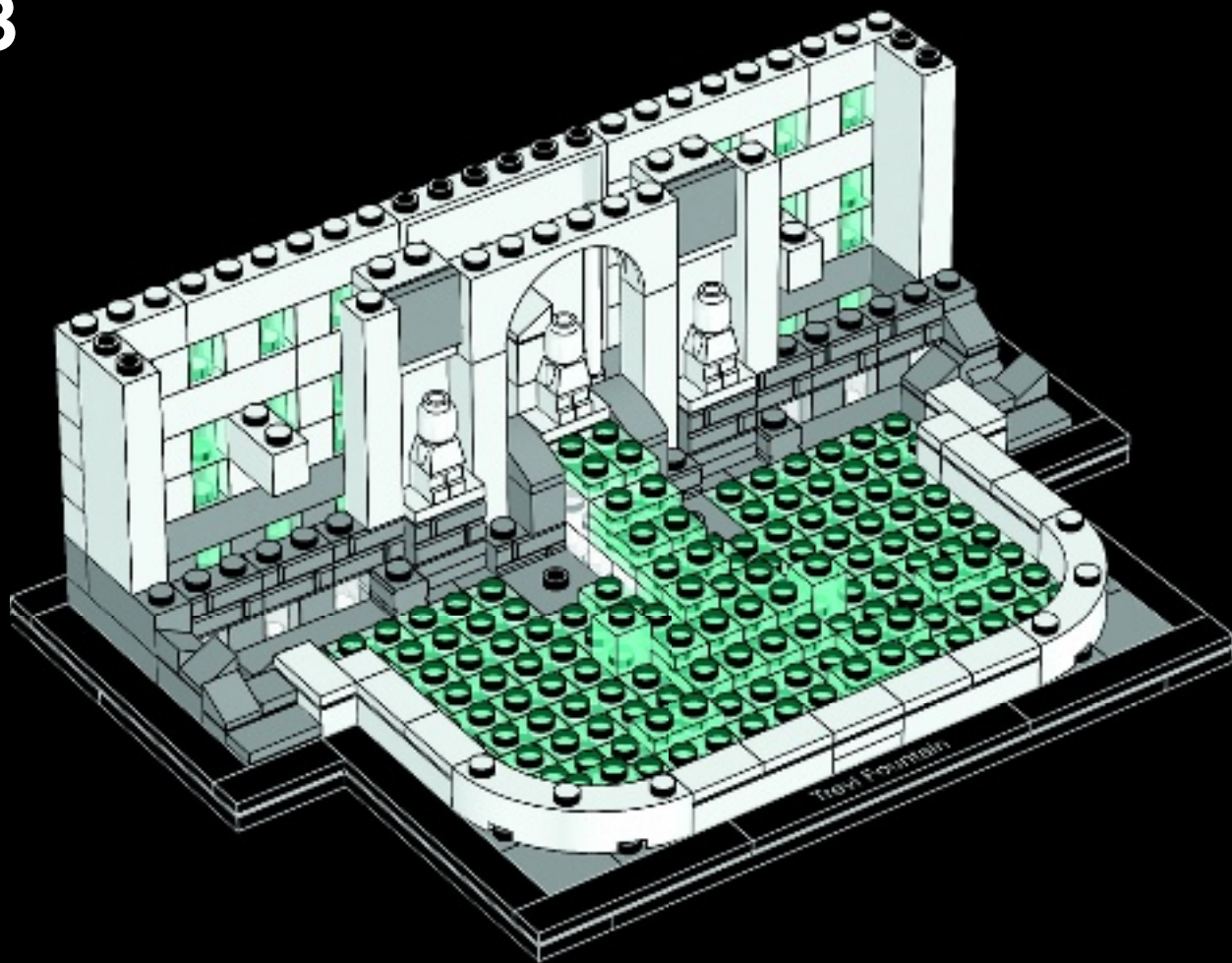



54

1



2



3



4



6x

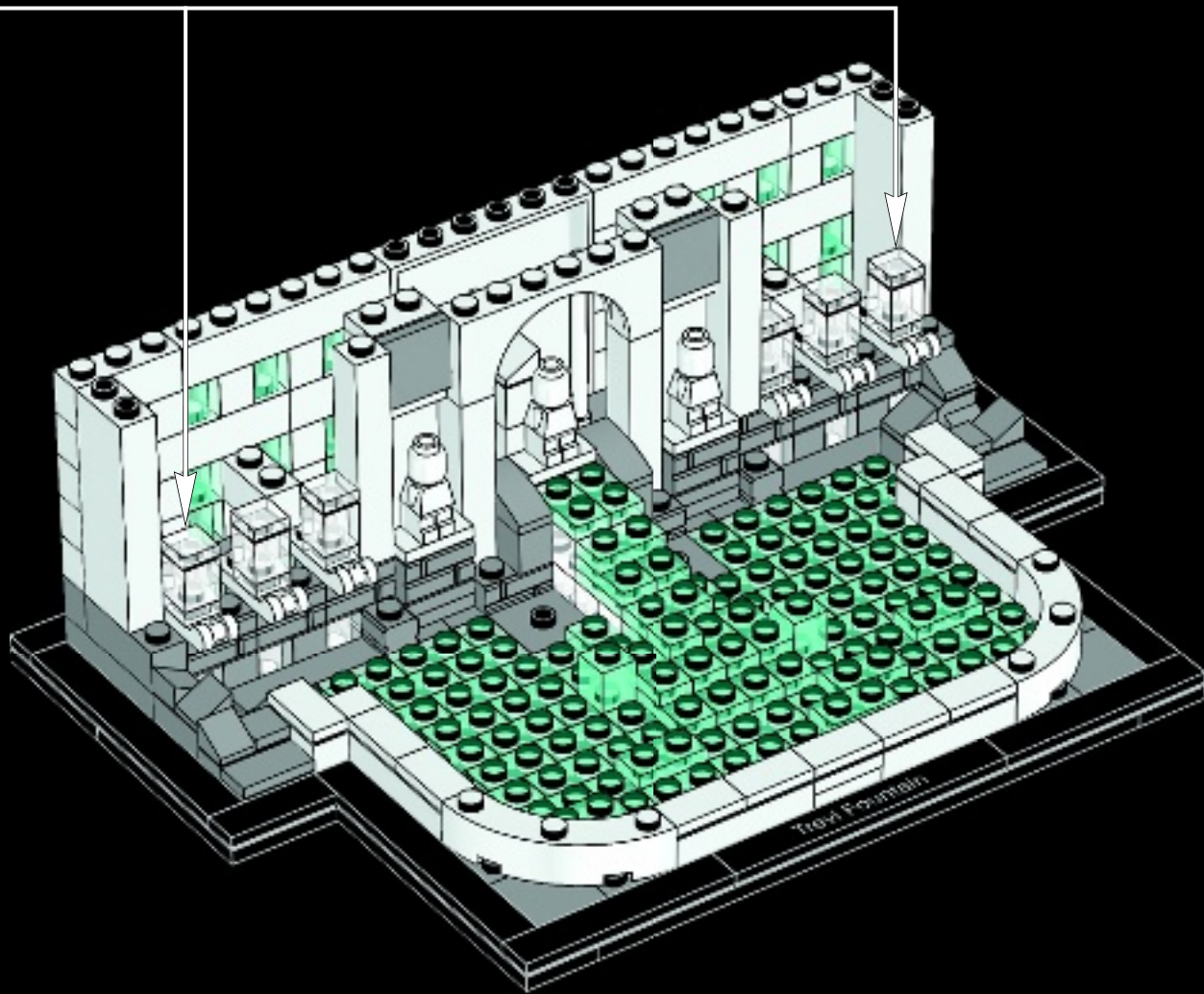



55

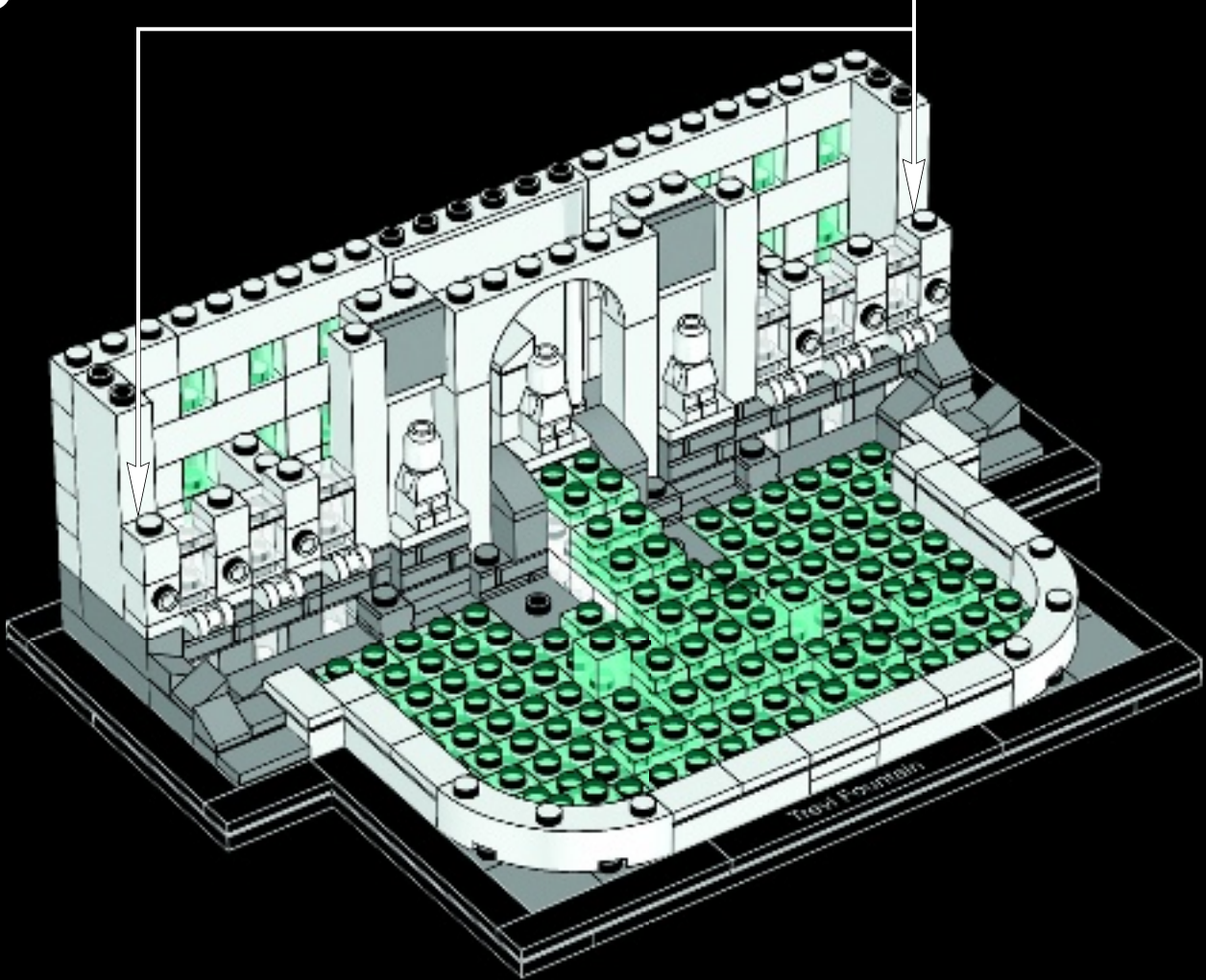



56

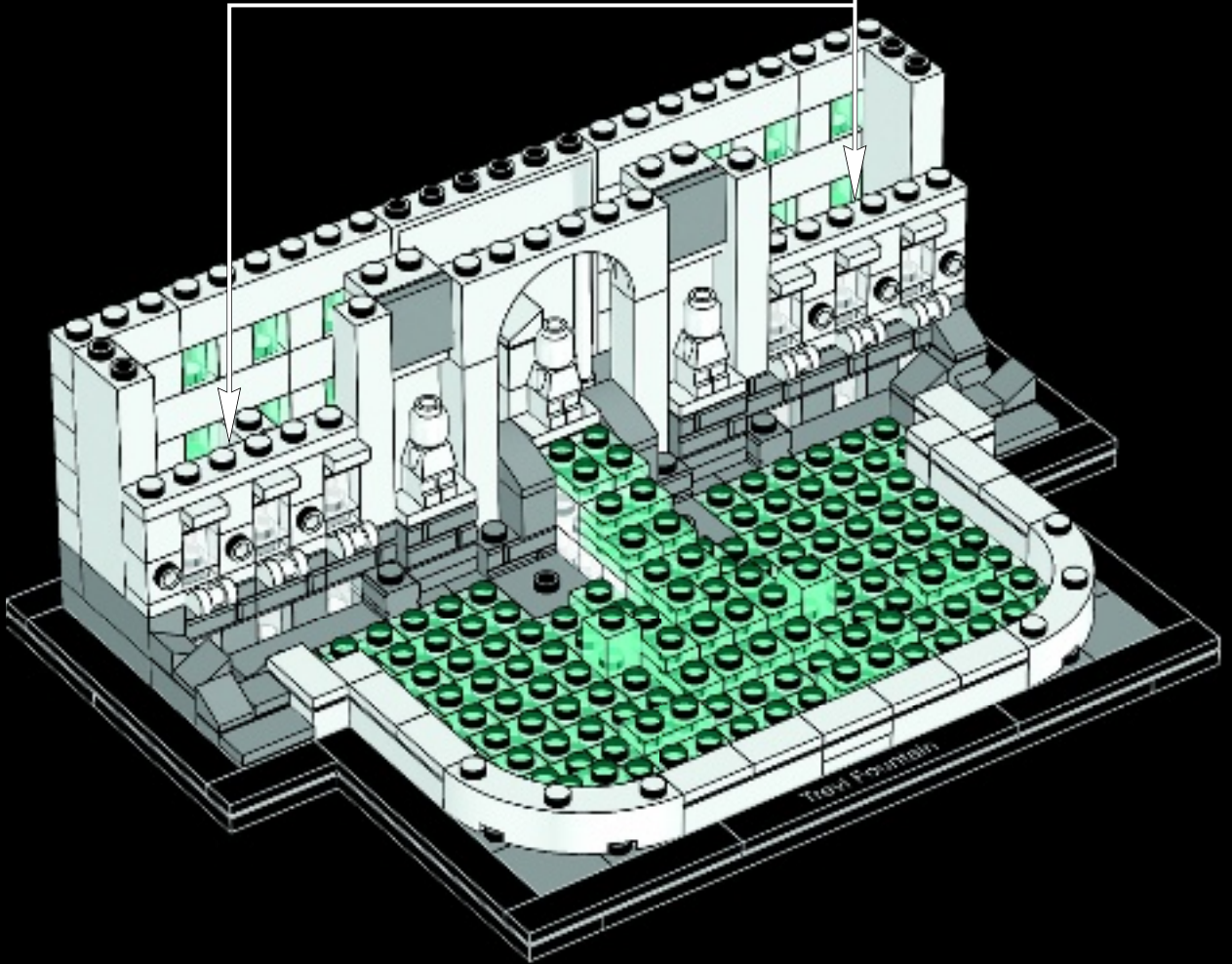
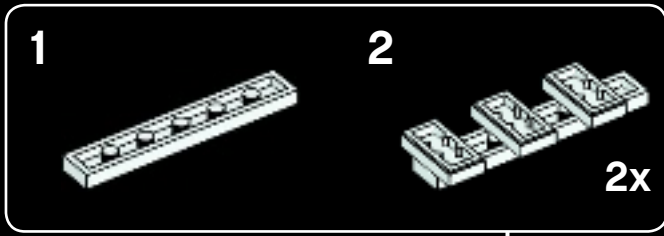



57

1



2



3



4



6x

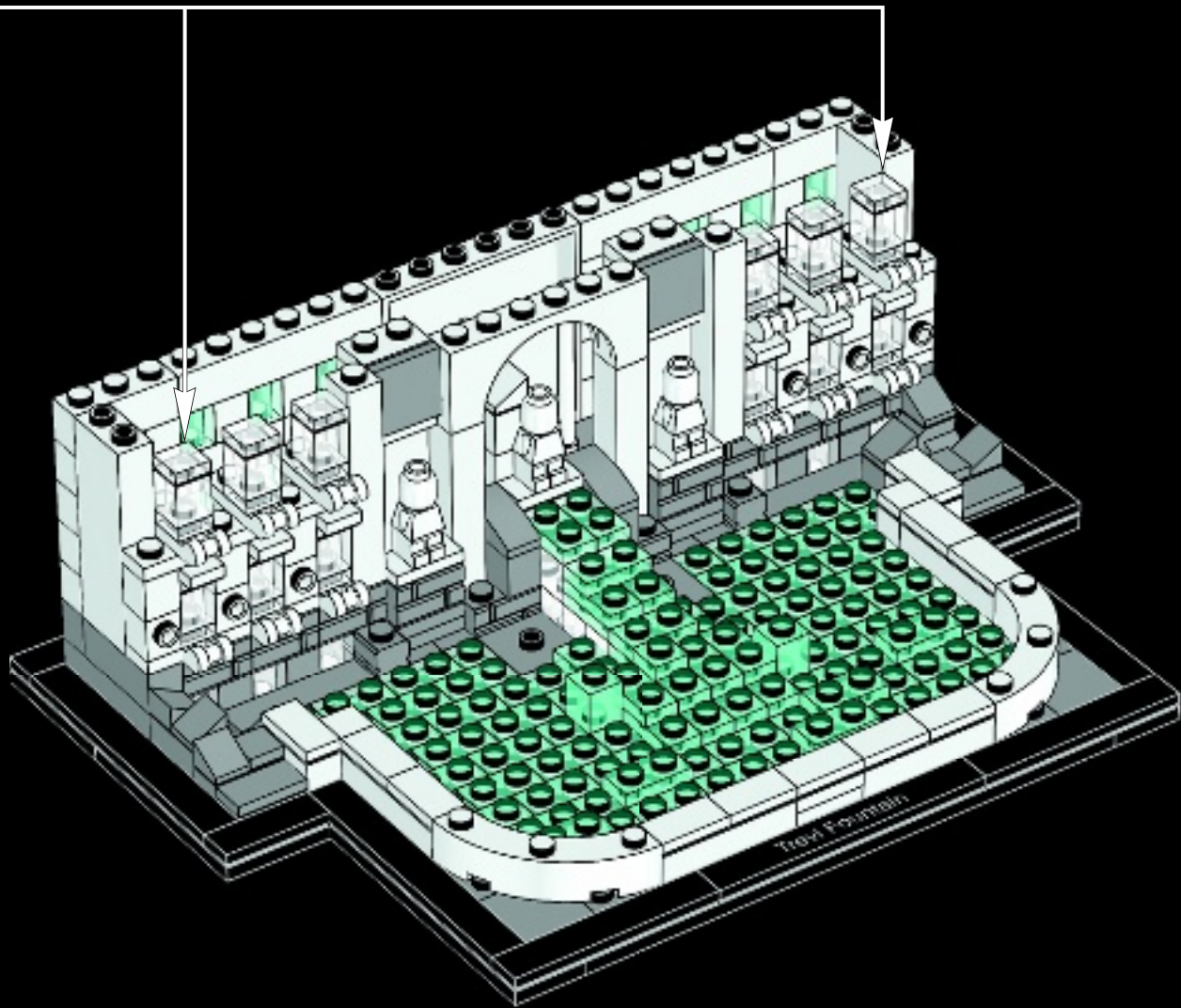

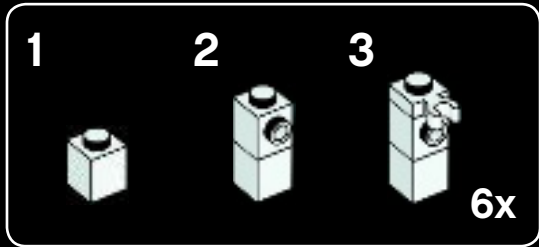

58

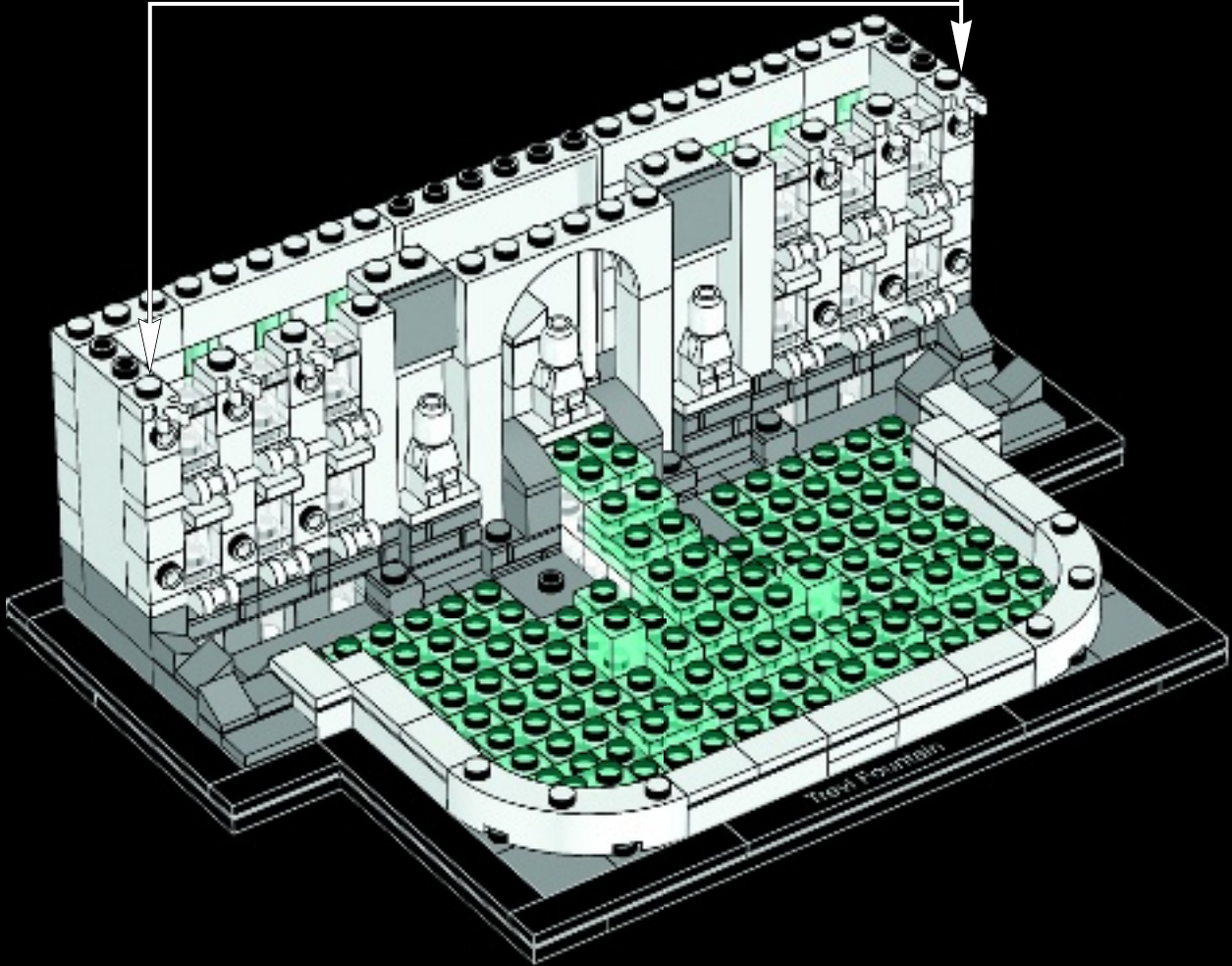



59

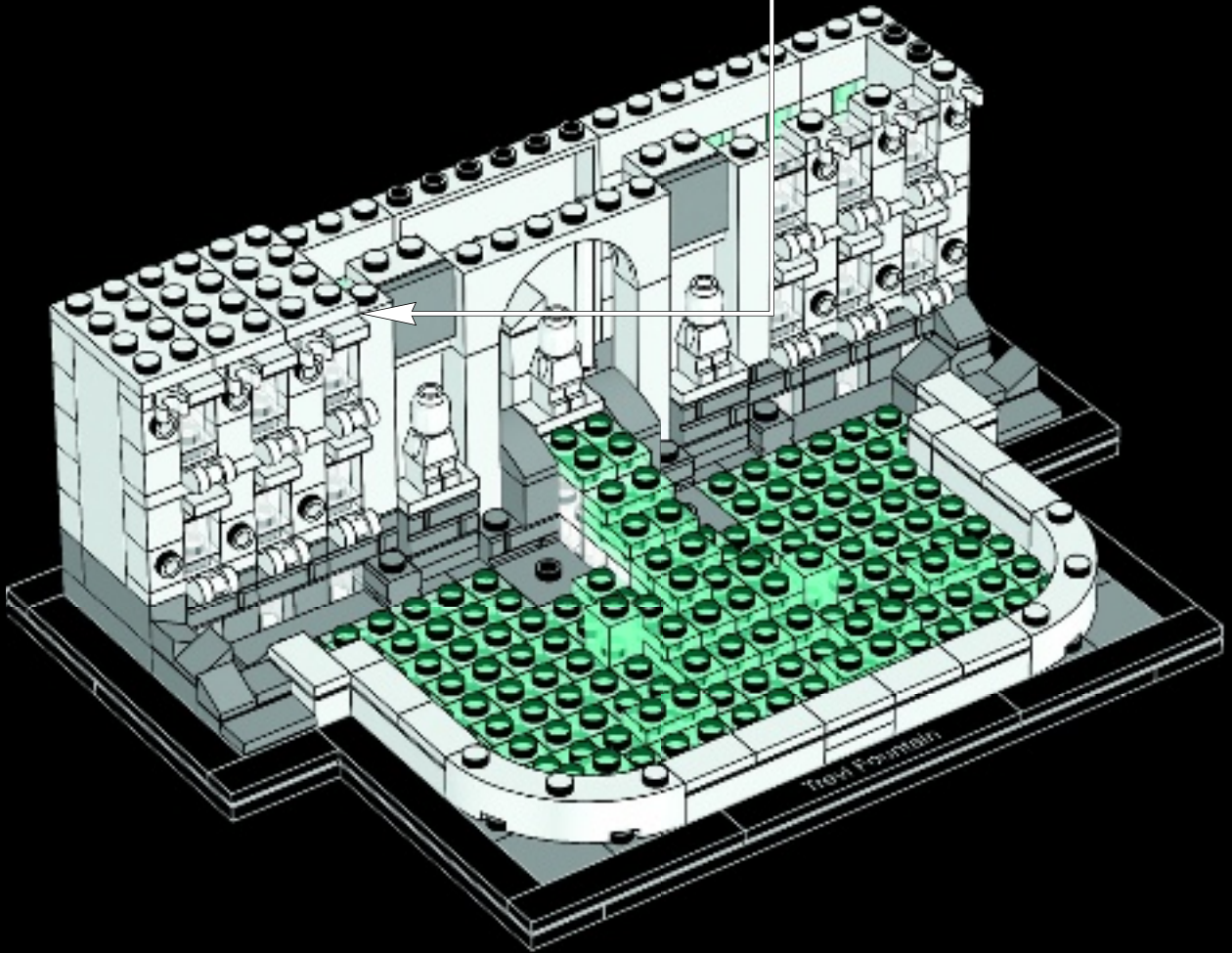



60

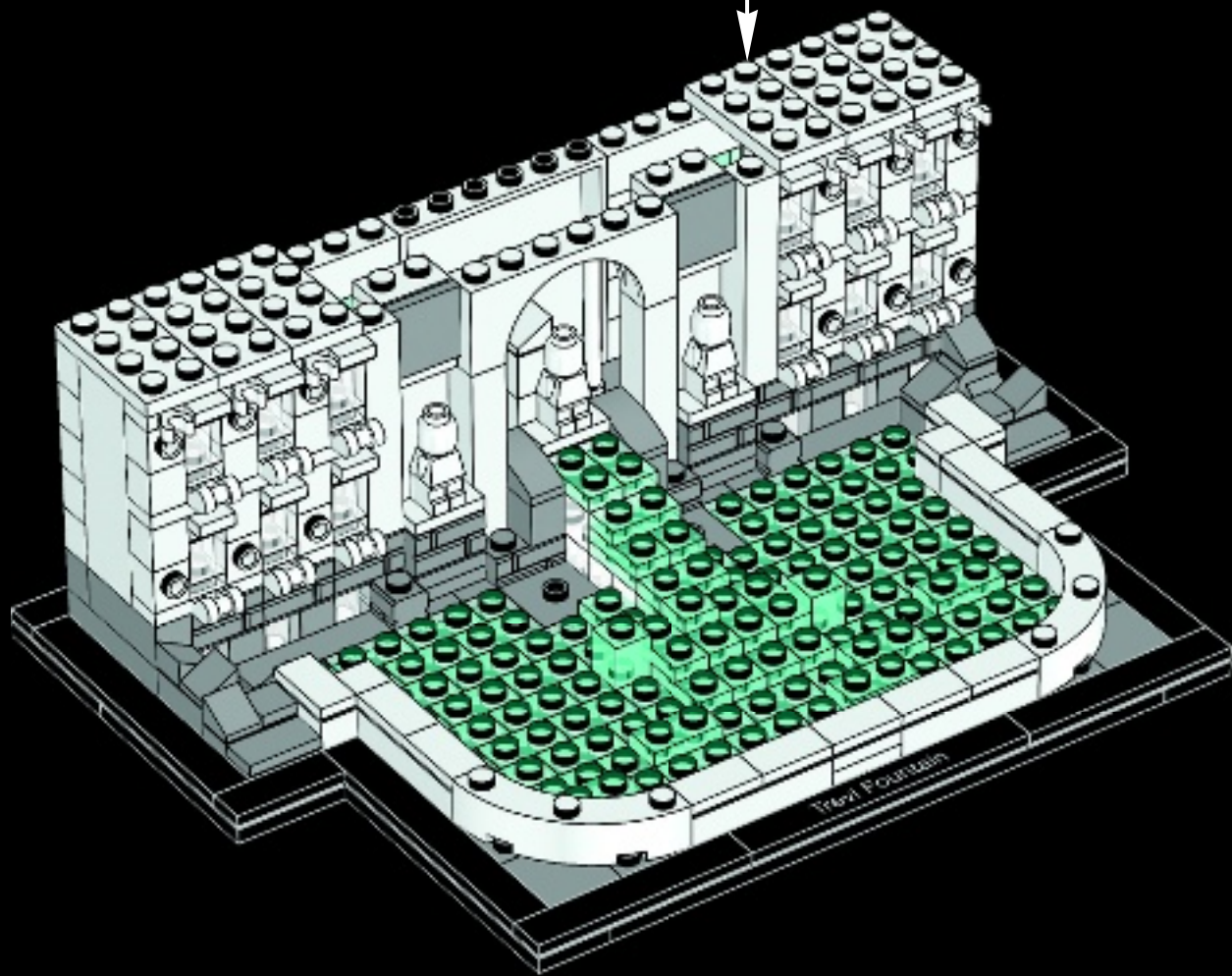



4x

61

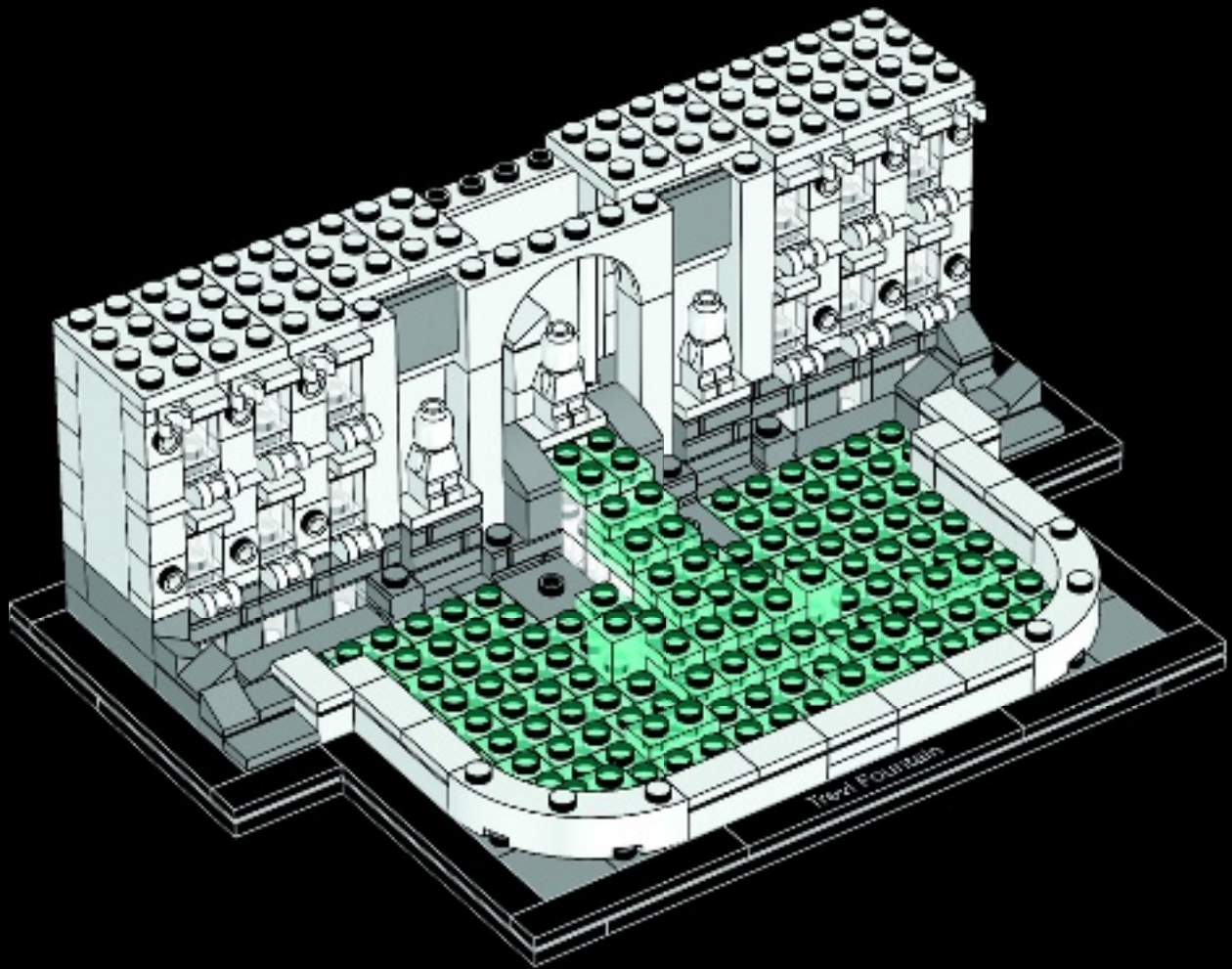



4x

62

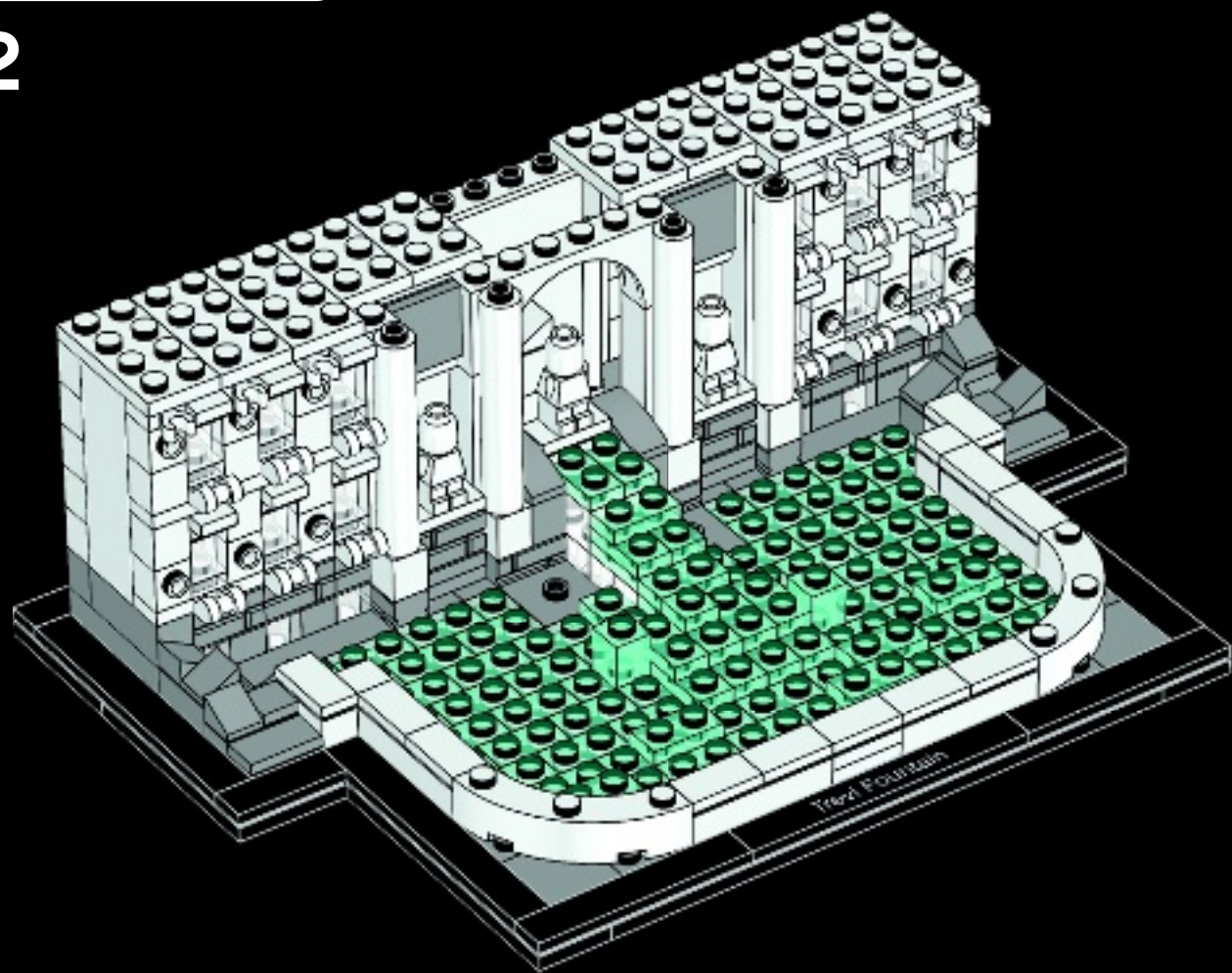



4x

63

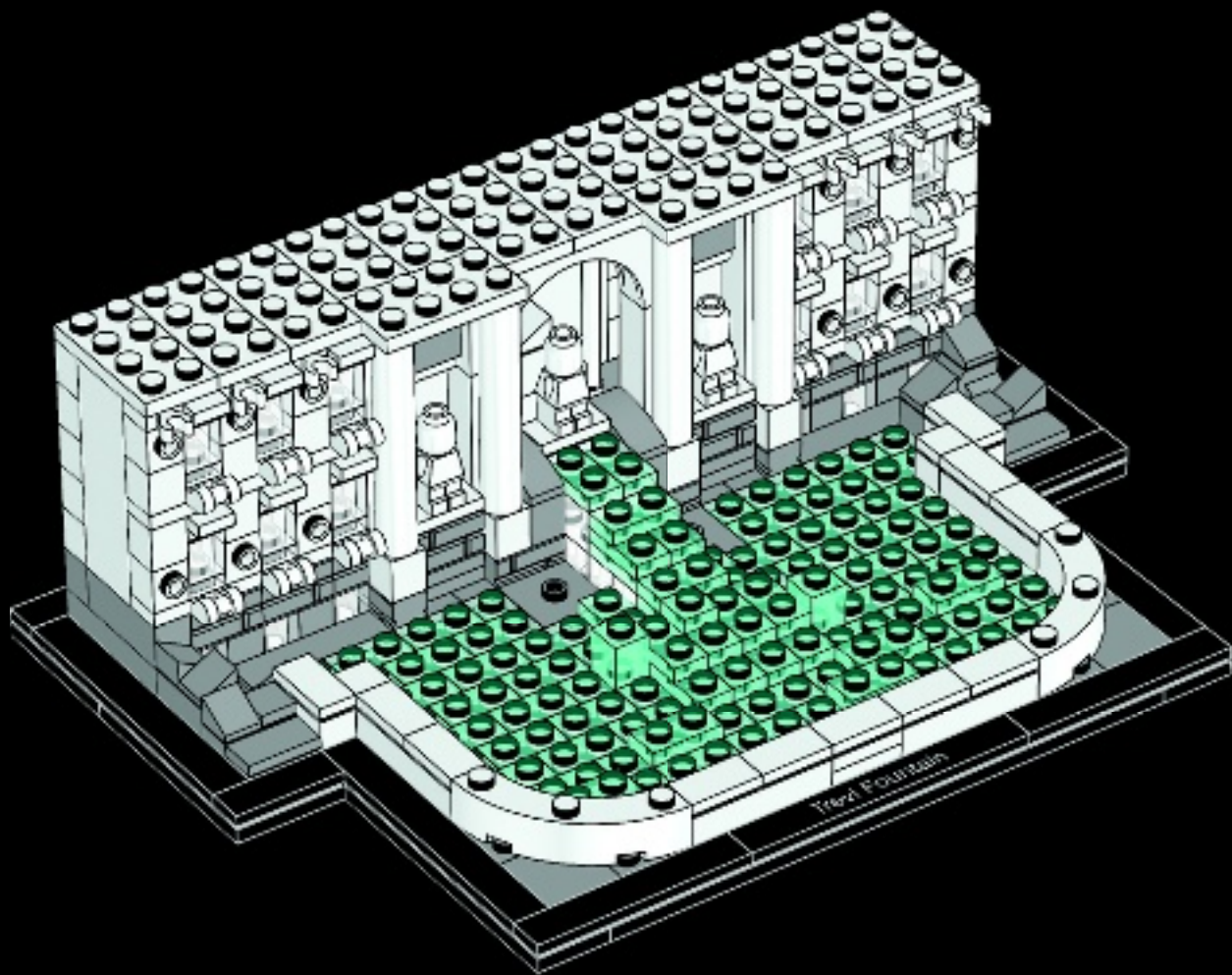



6x

64

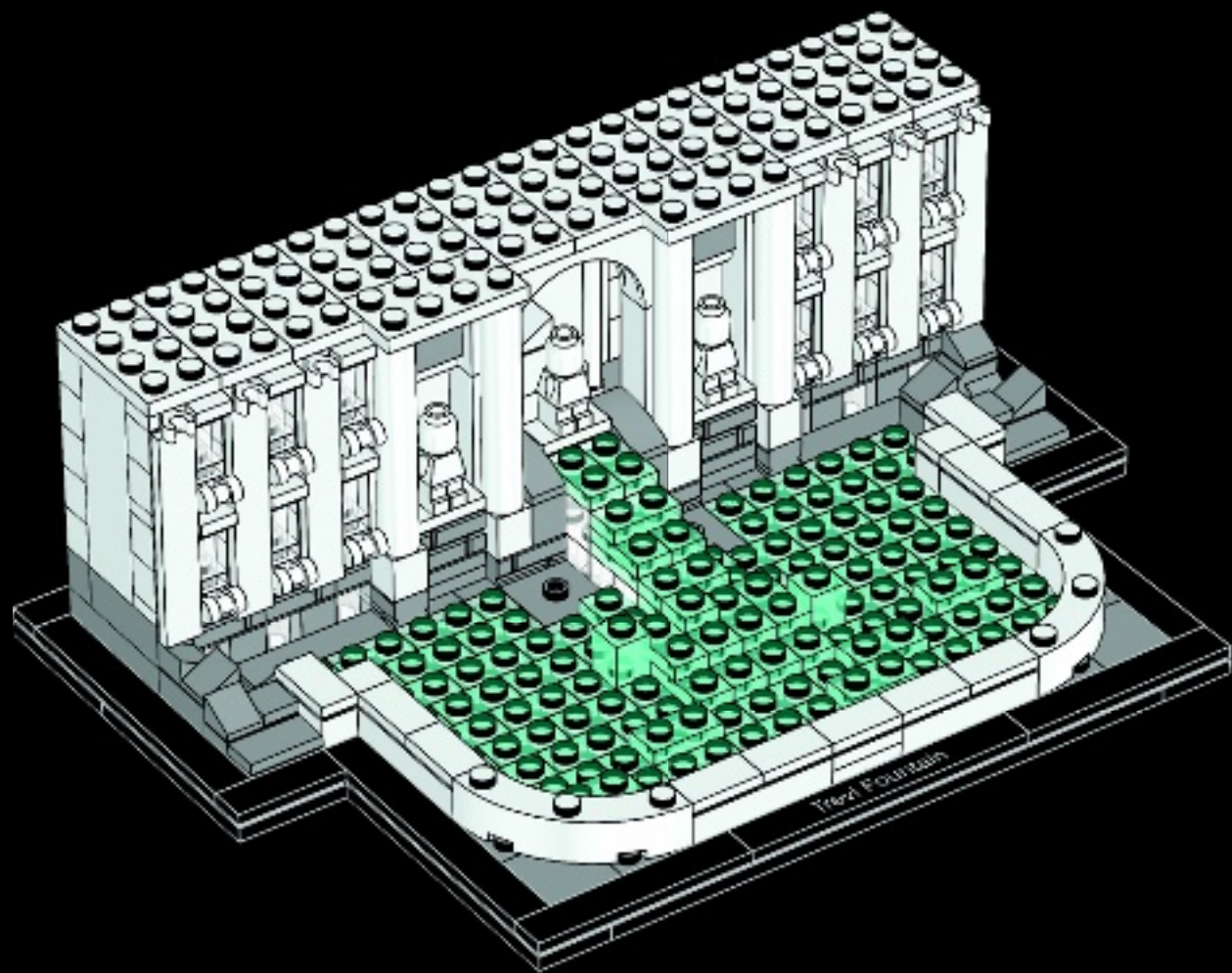



2x



2x



2x

65

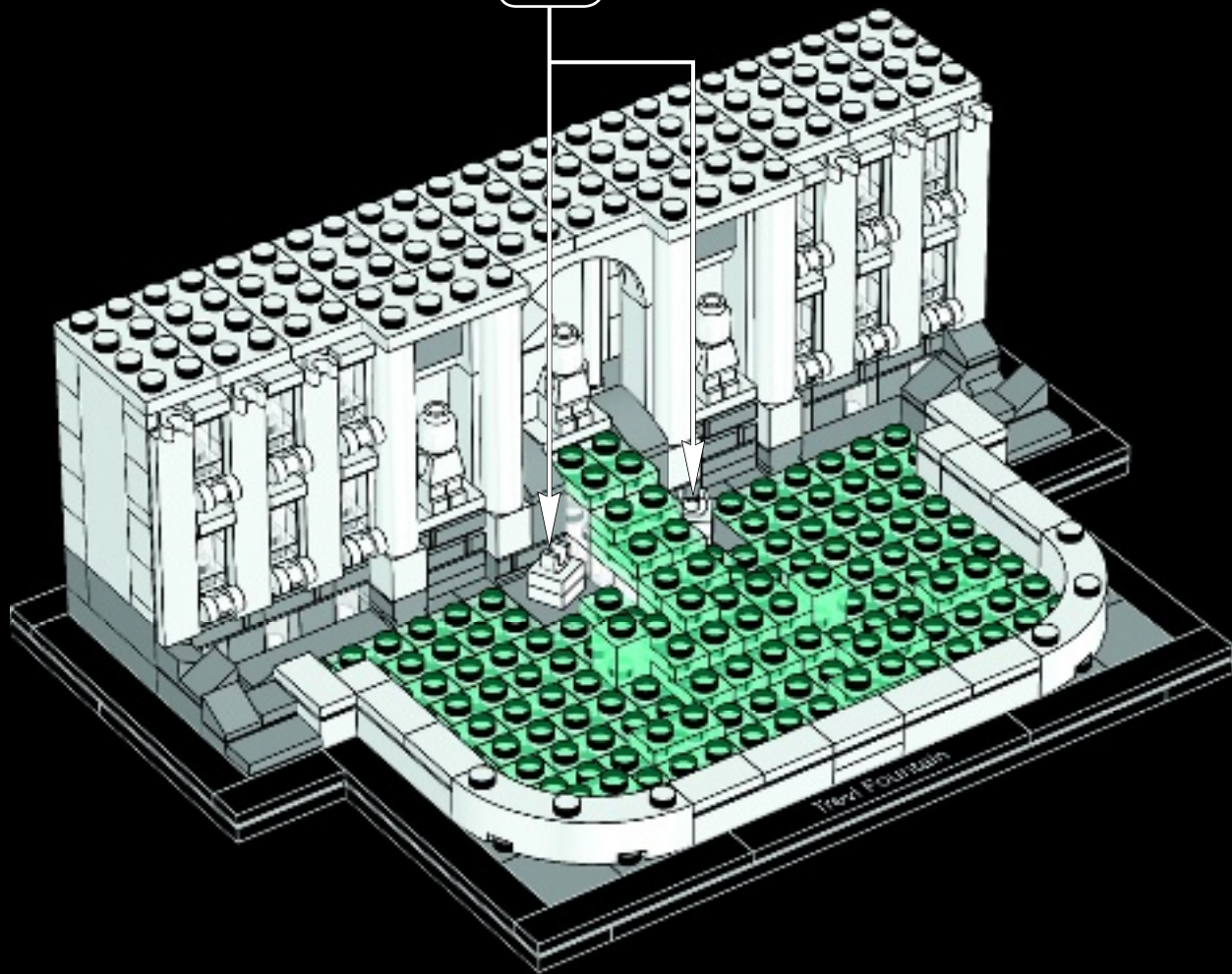



2x



2x

66

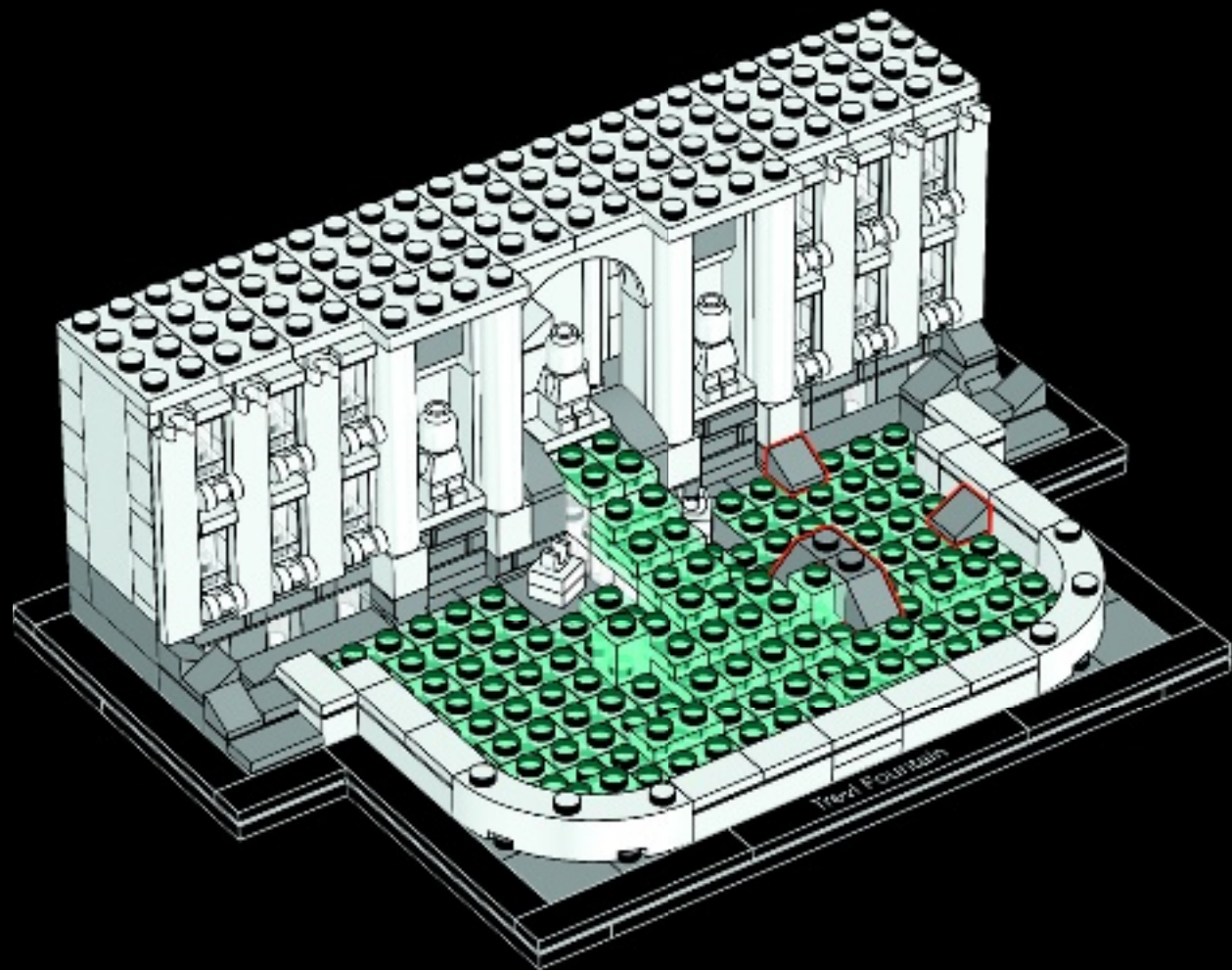

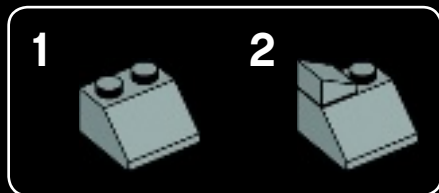

67

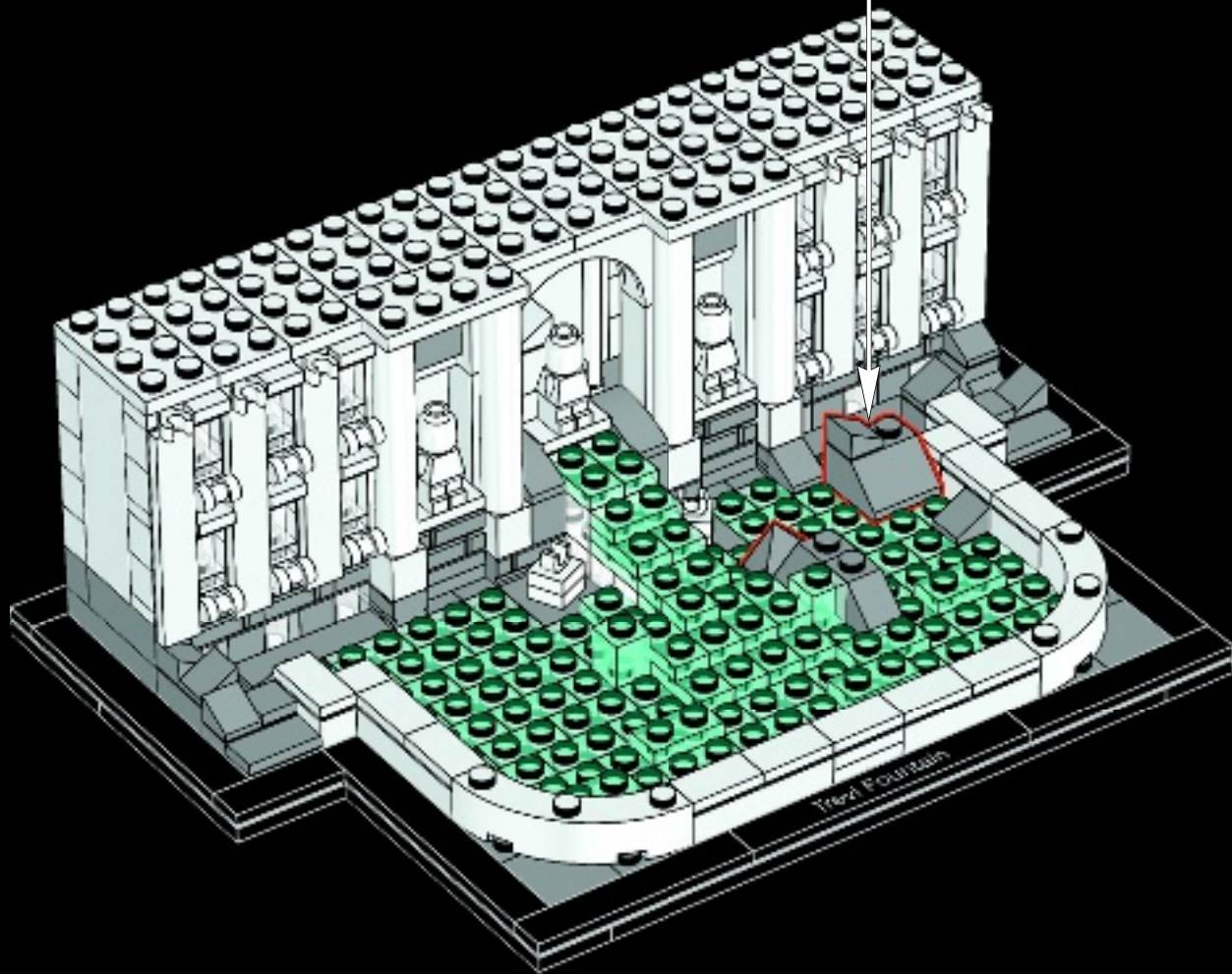

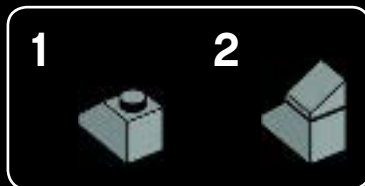

68

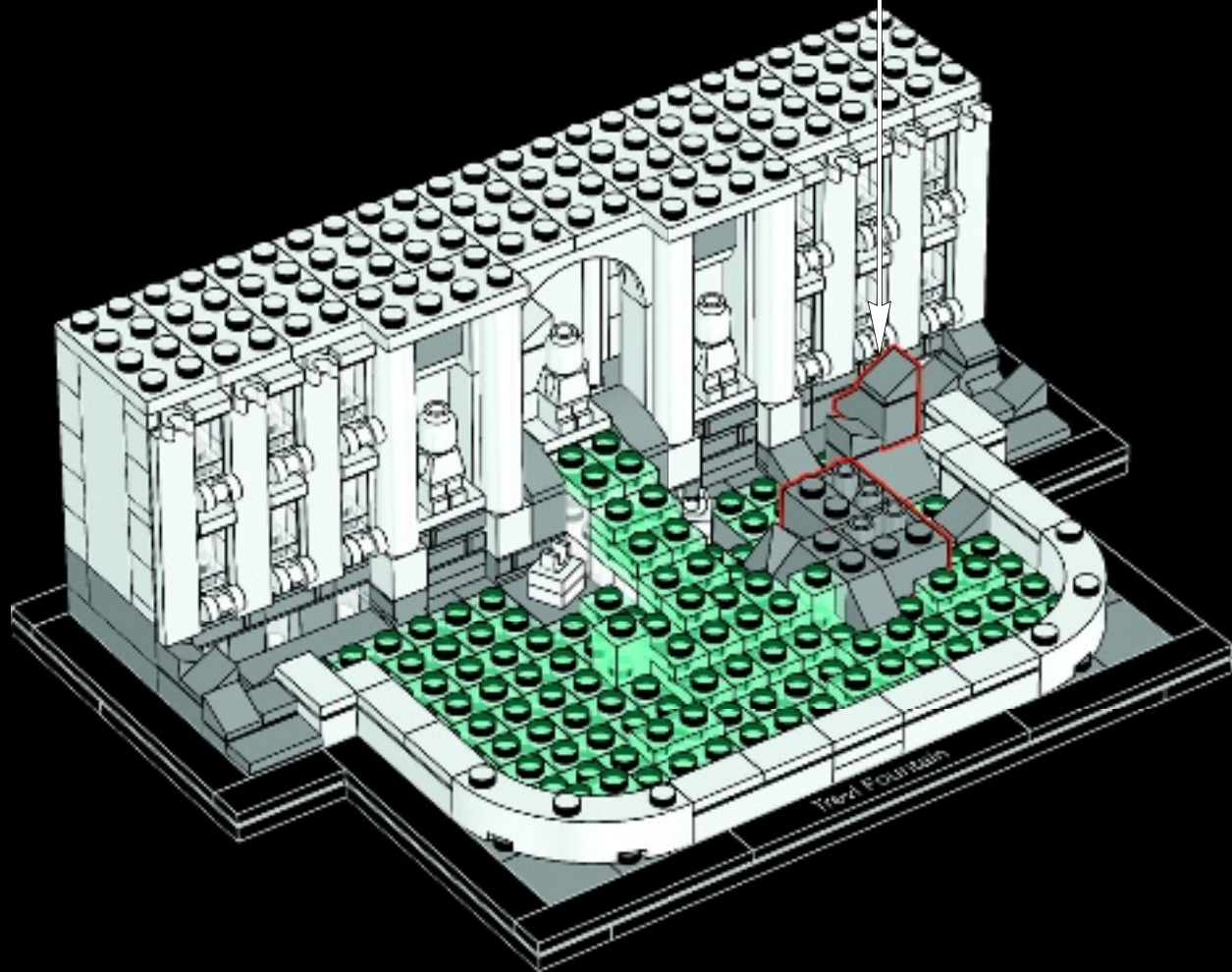



1x



1x



1x

69

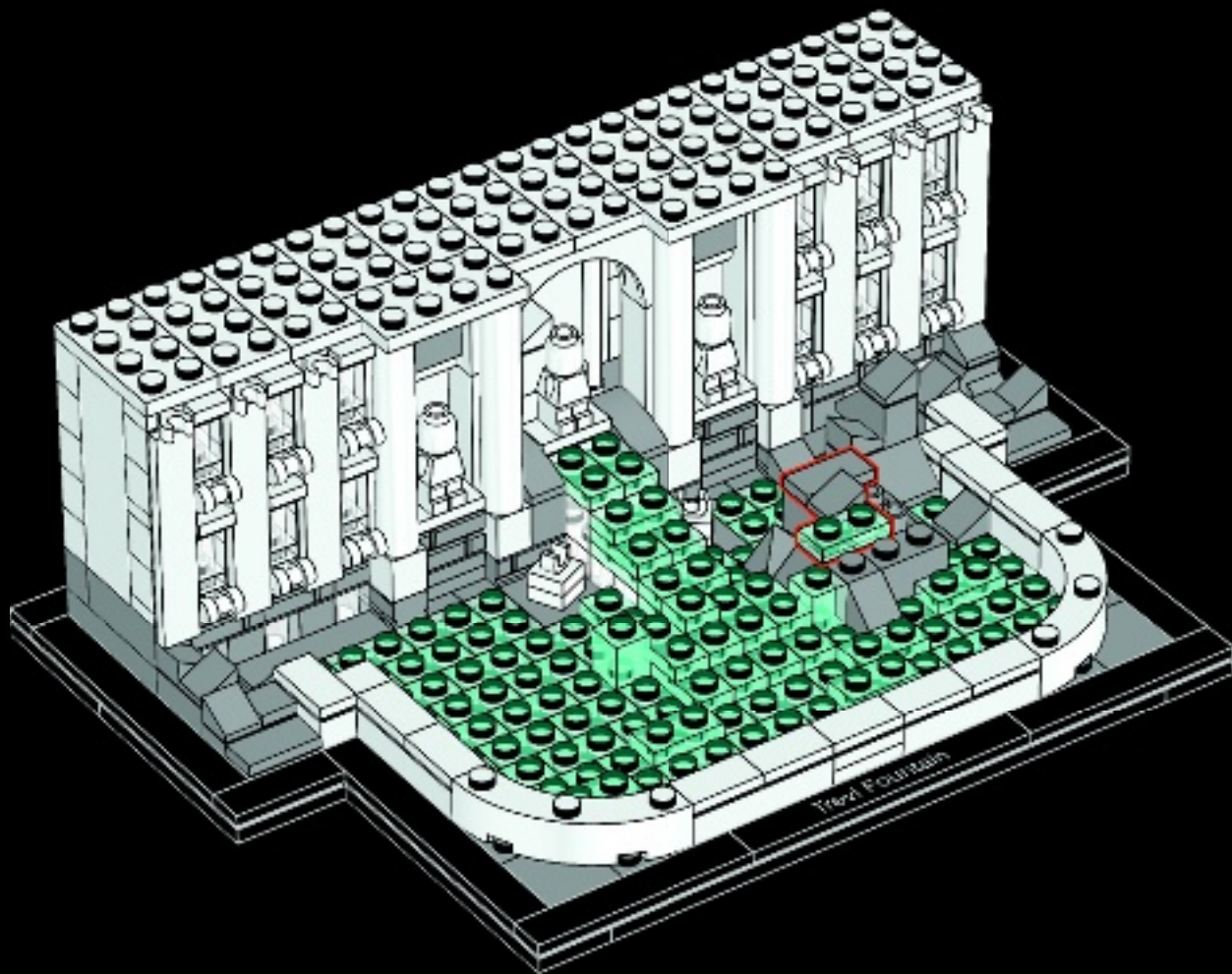



70

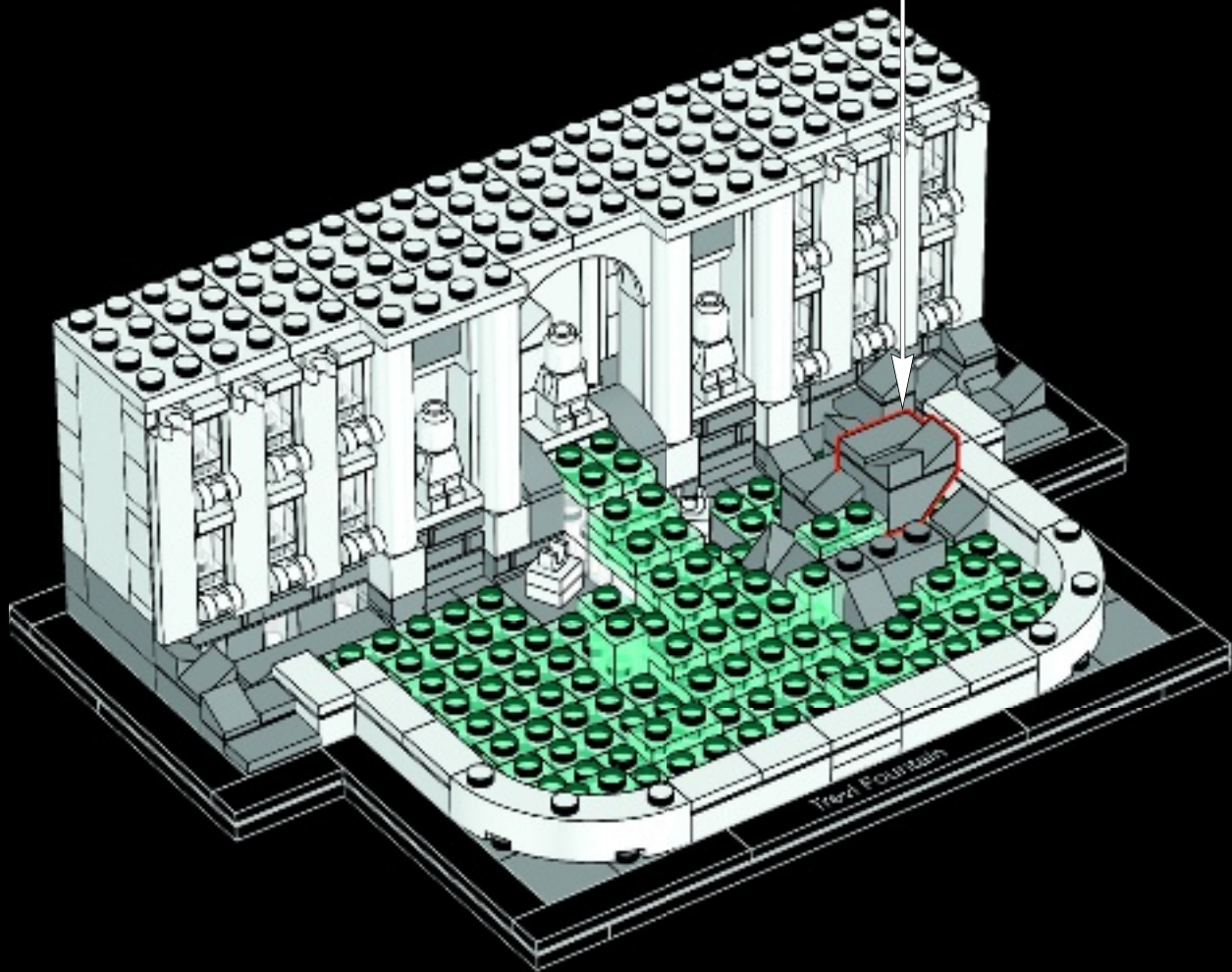
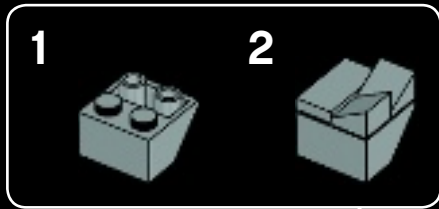



71

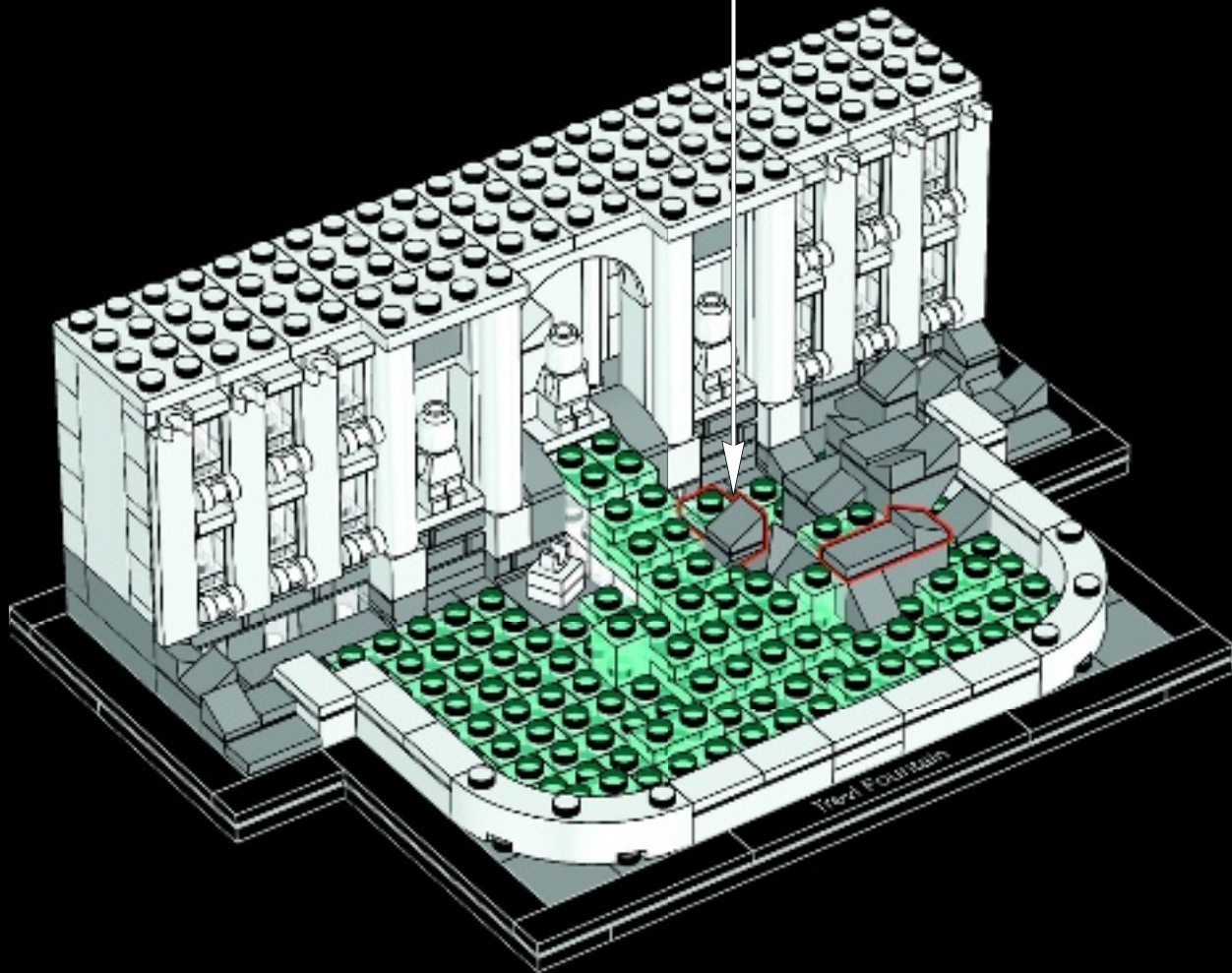



72

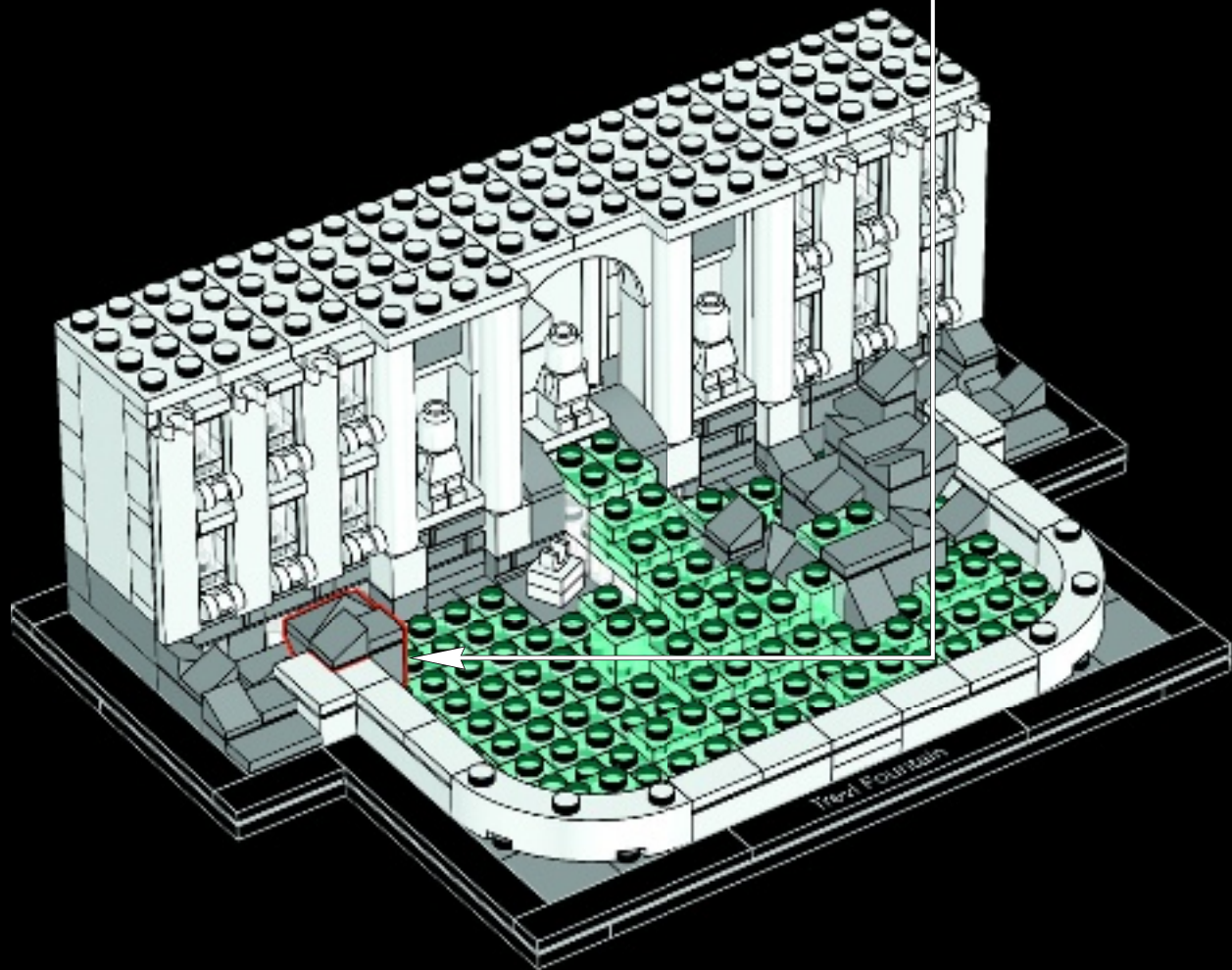



73

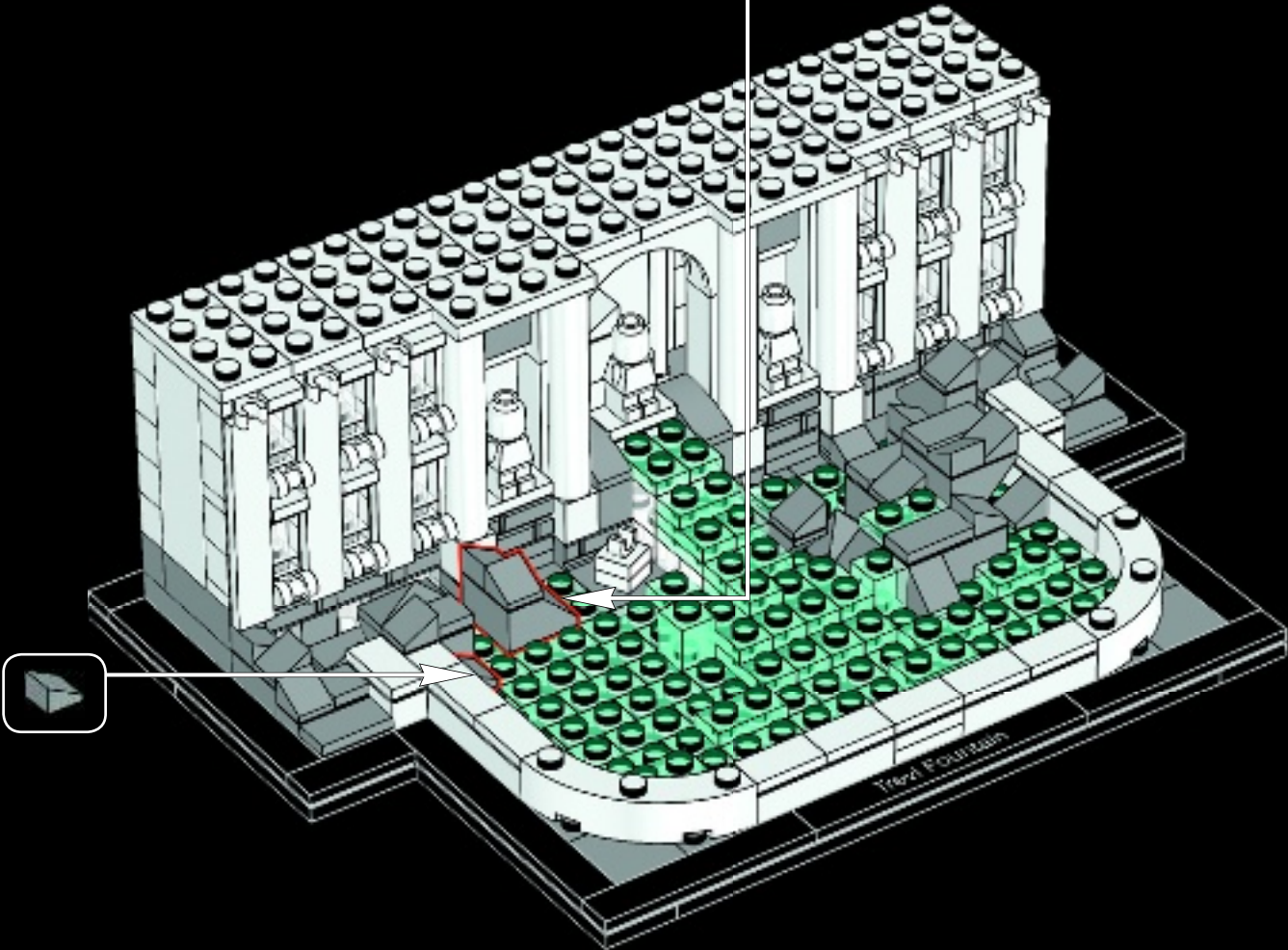
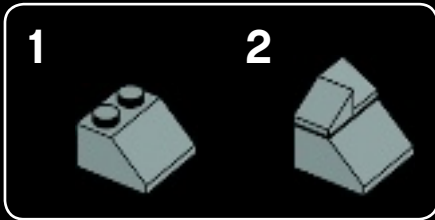

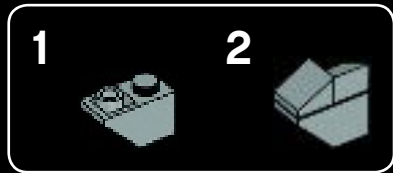

74

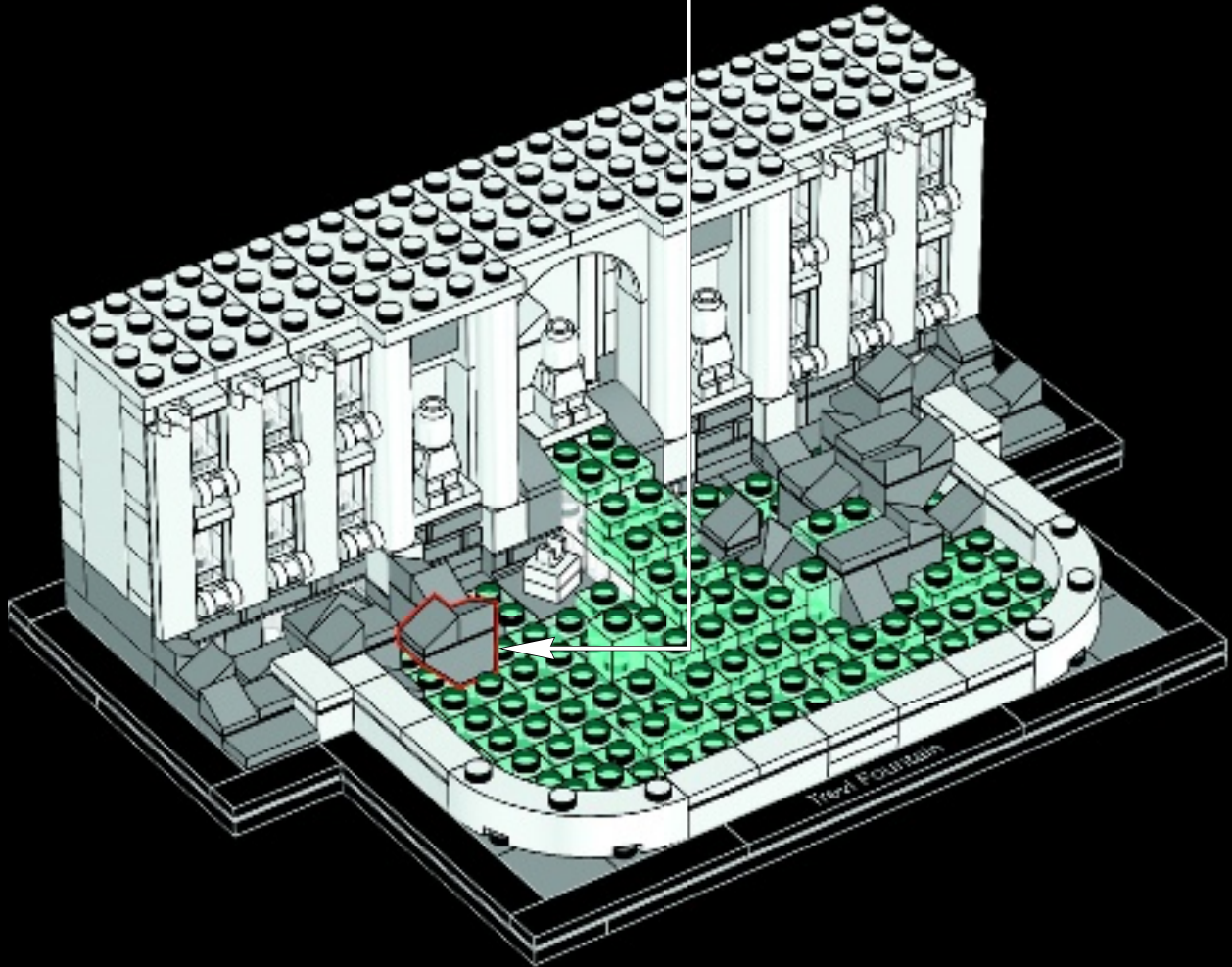



75

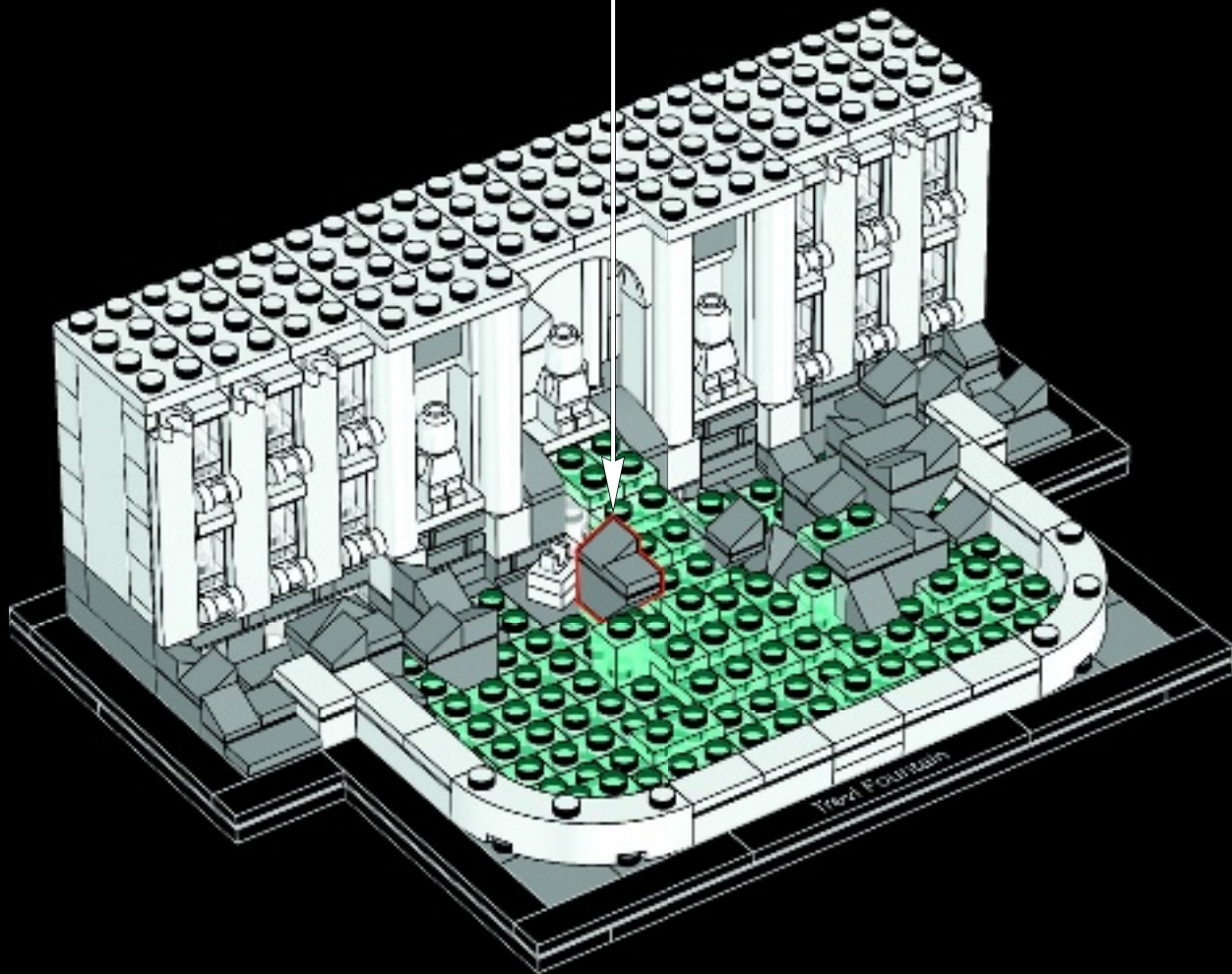



76

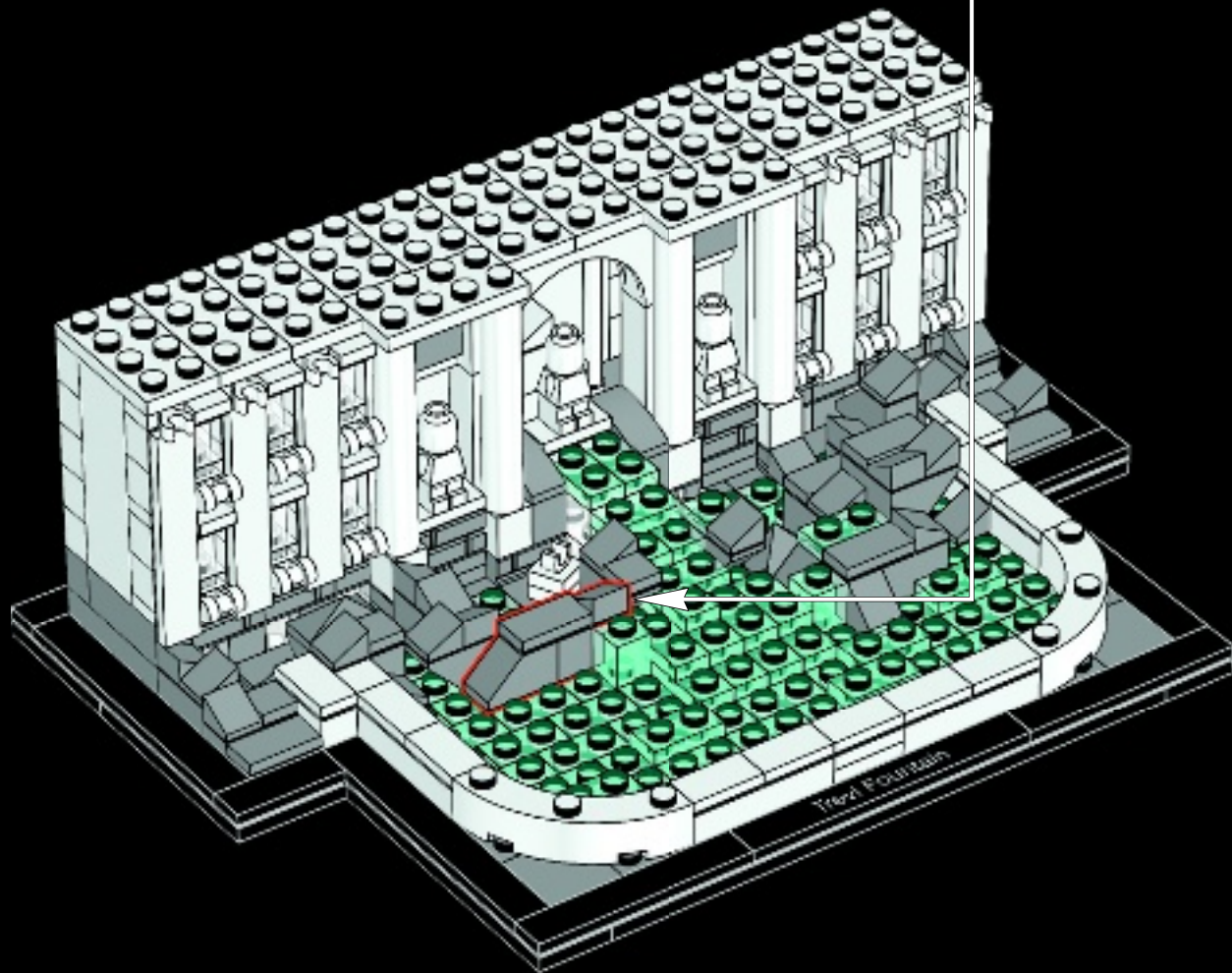
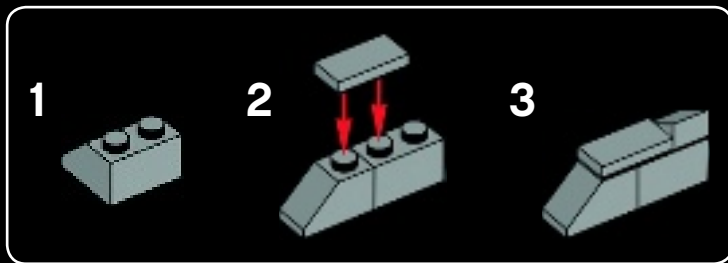

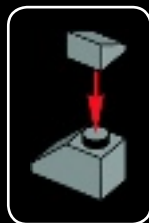

77

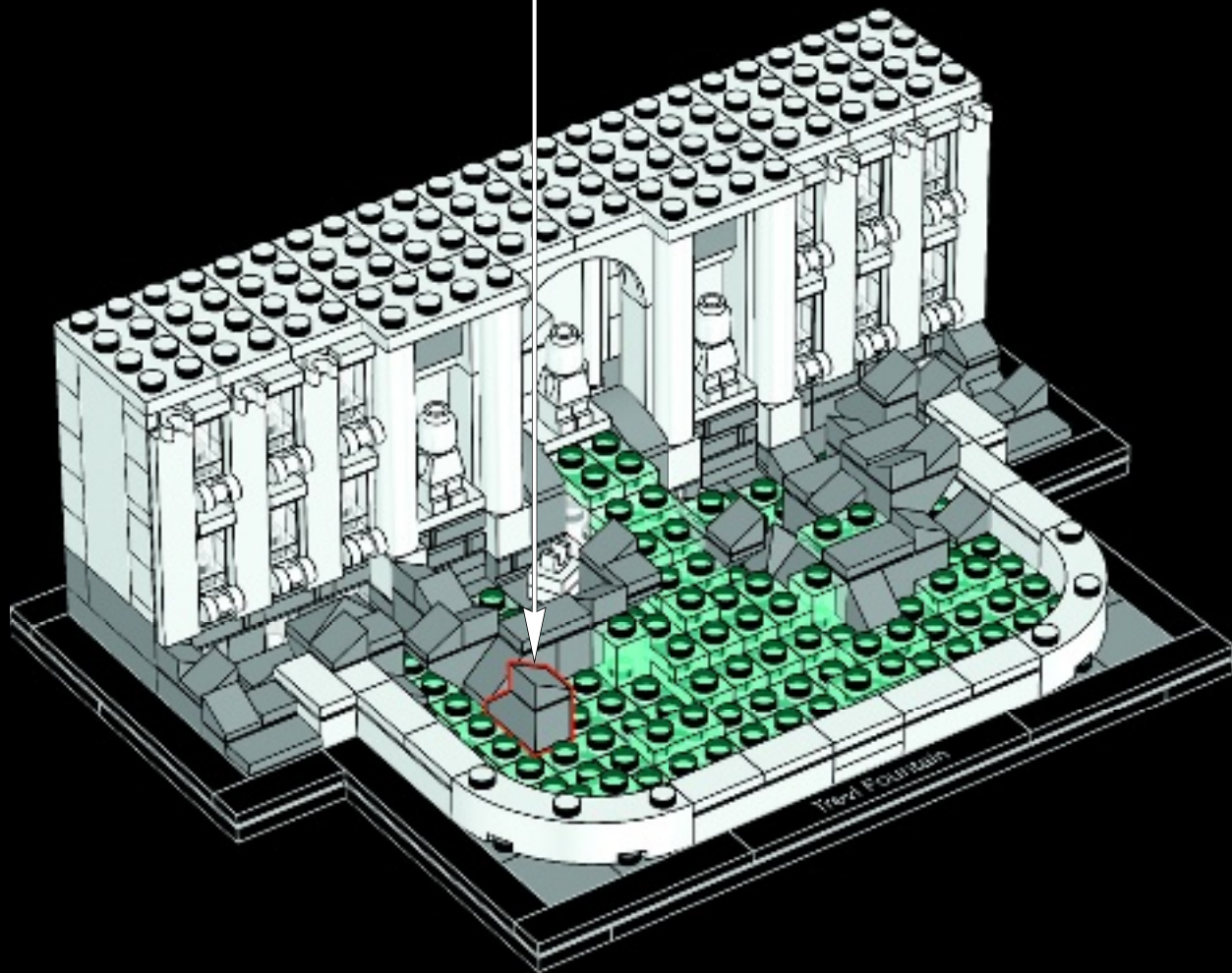



78

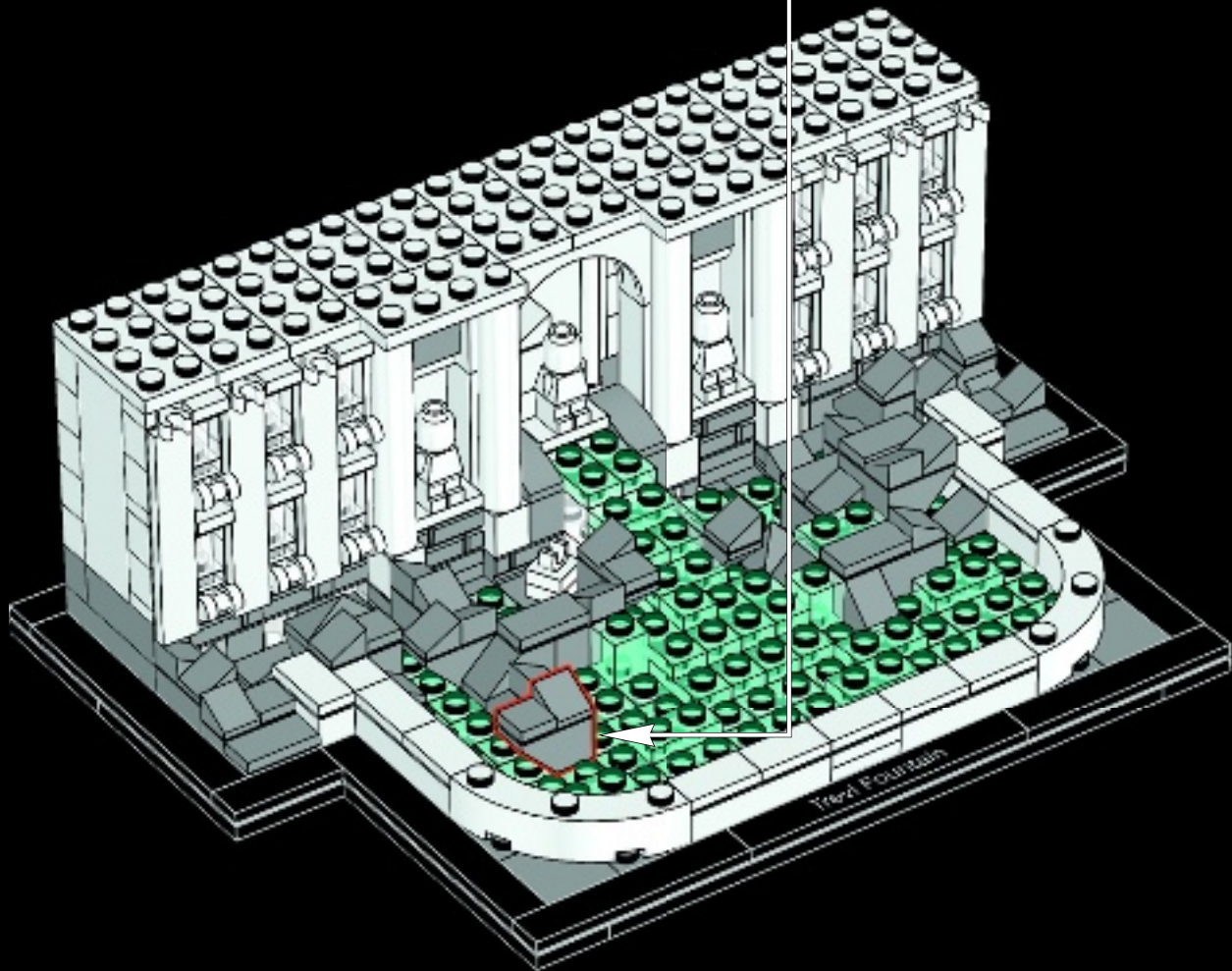



79

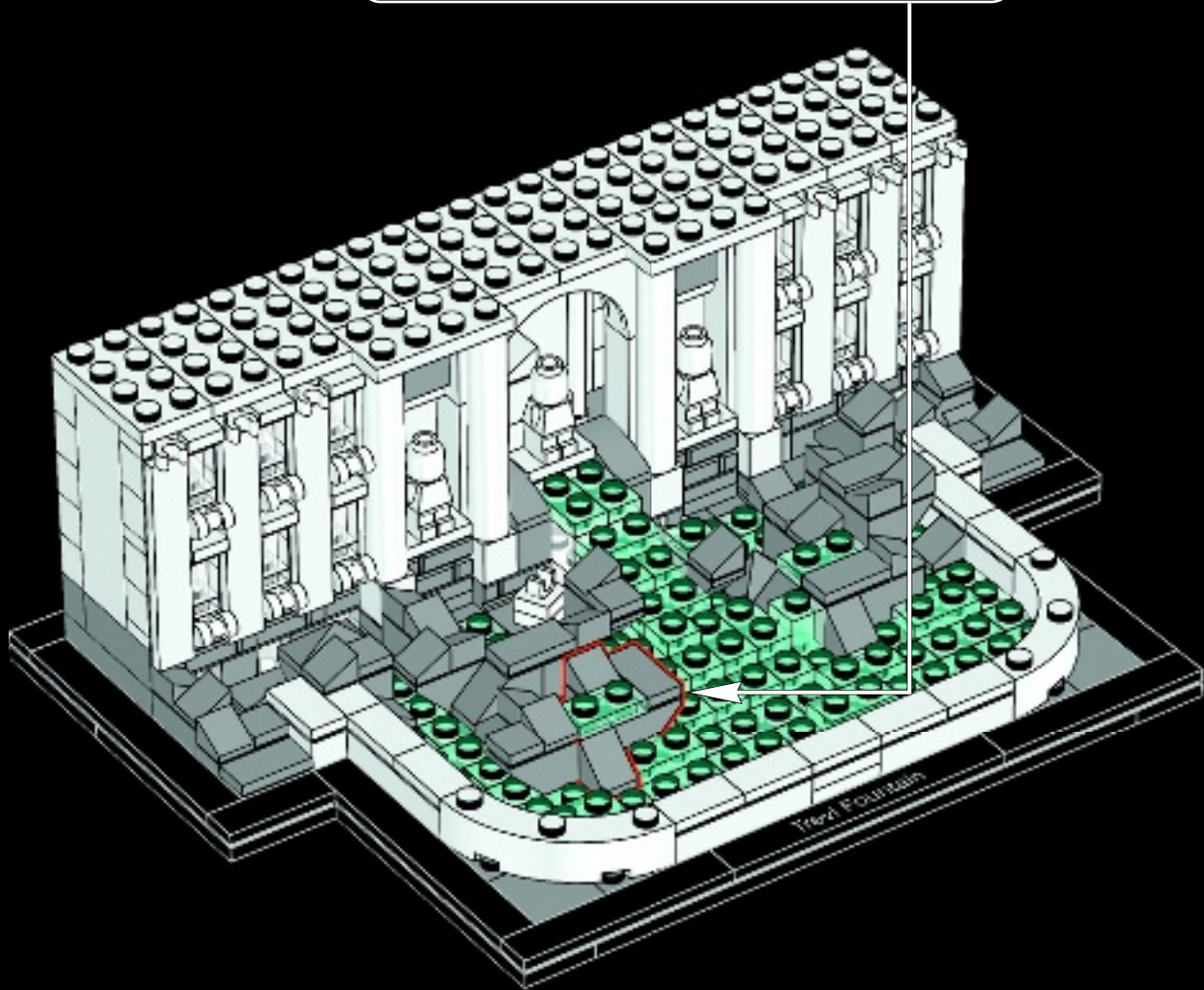
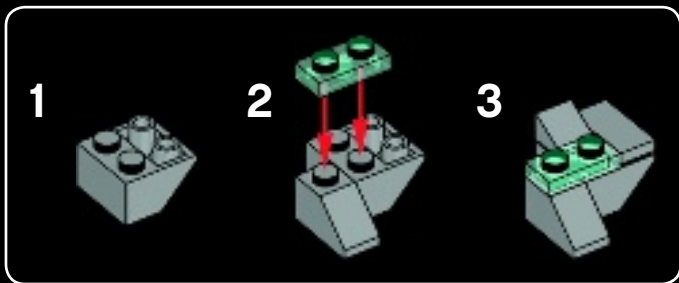

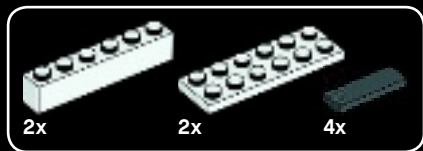

80

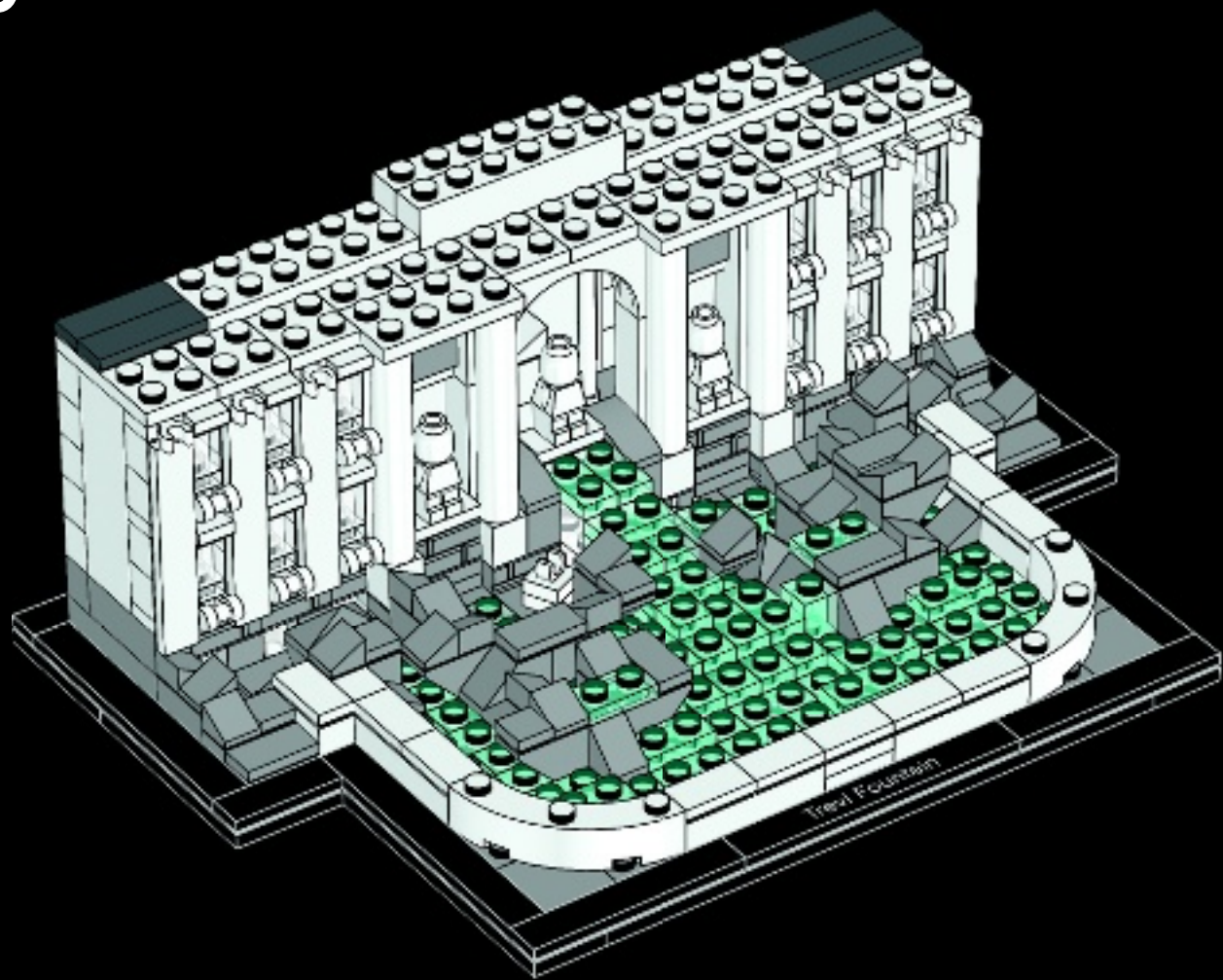



81

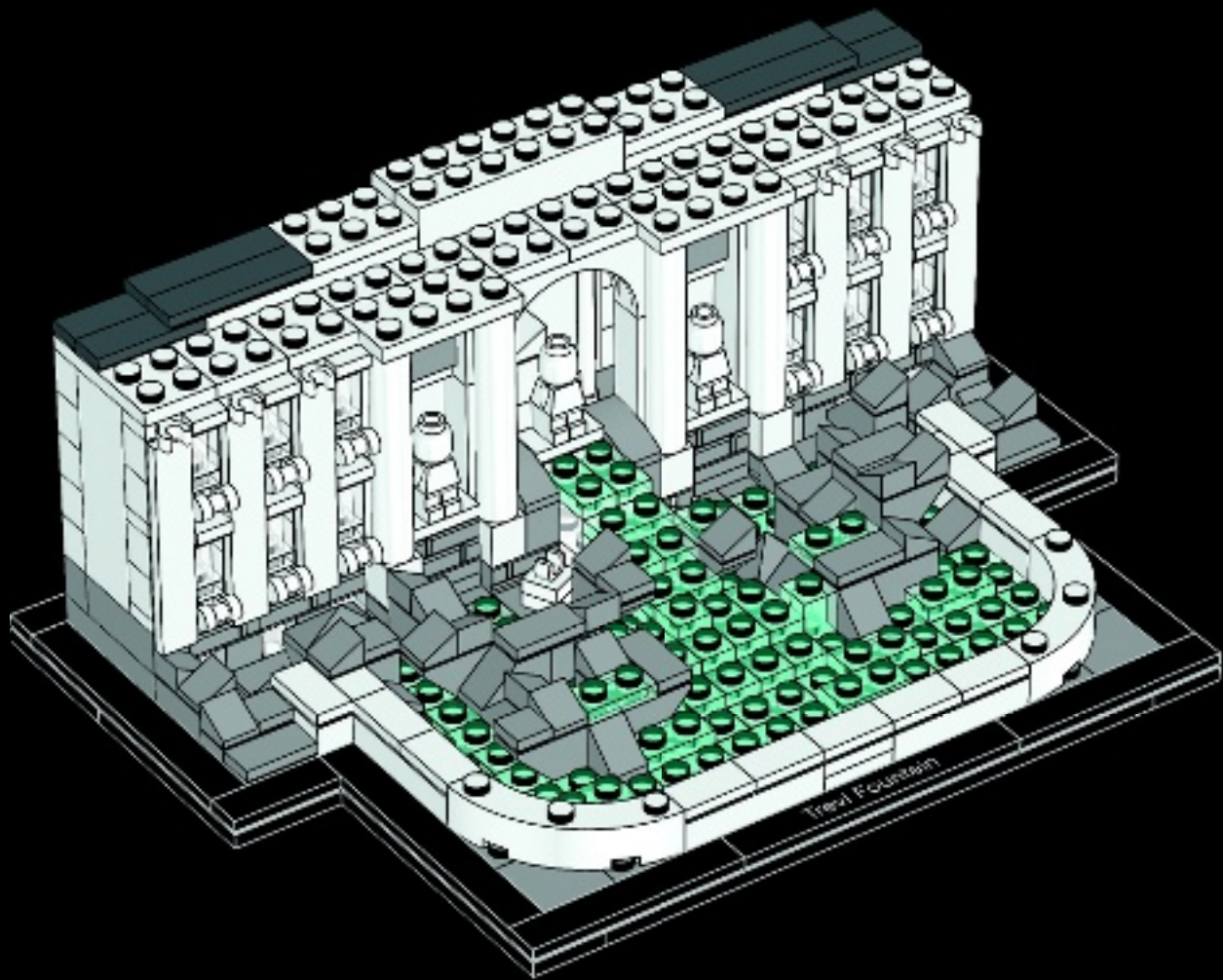

4x

82





4x

83

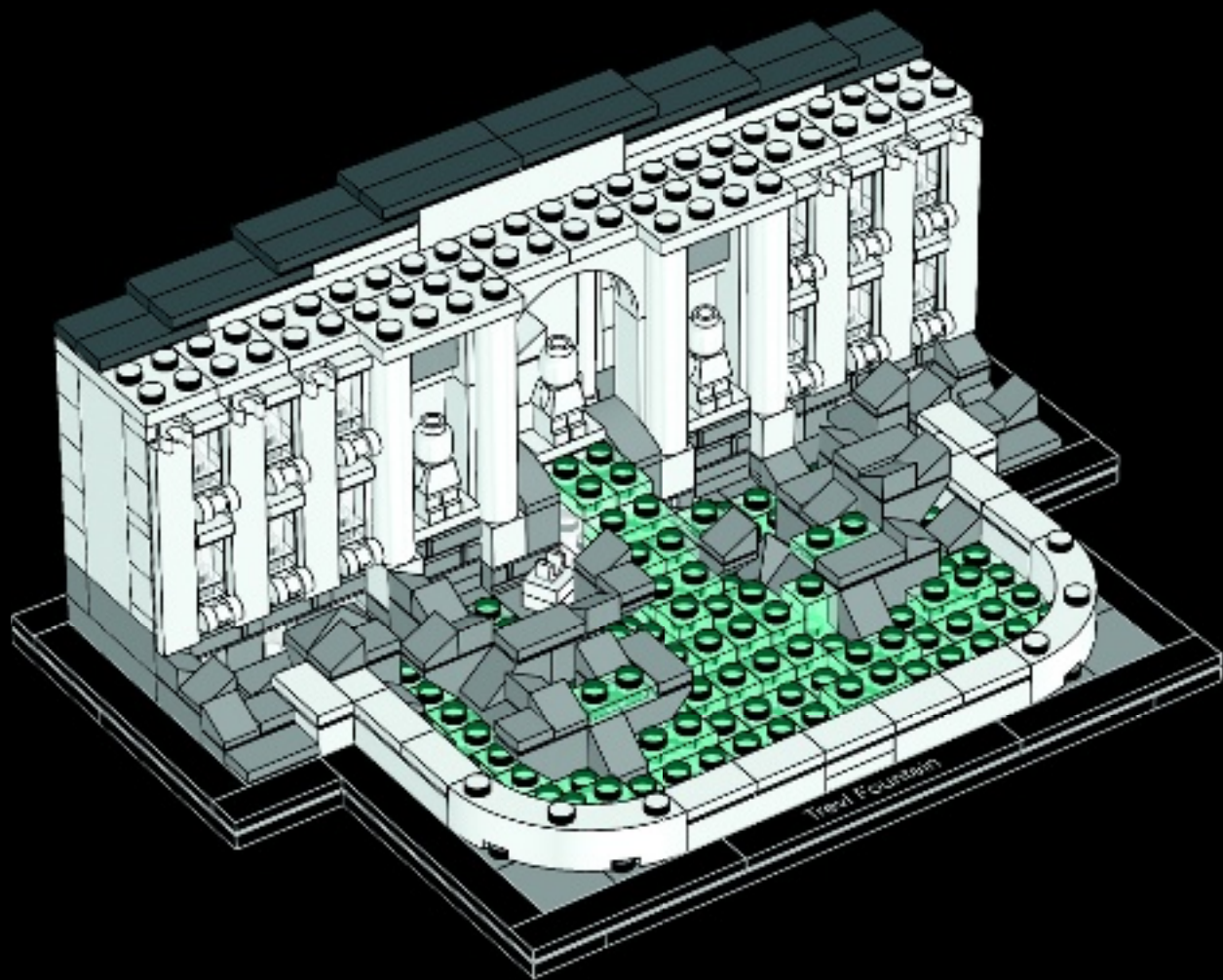



12x

84





8x

85



4x

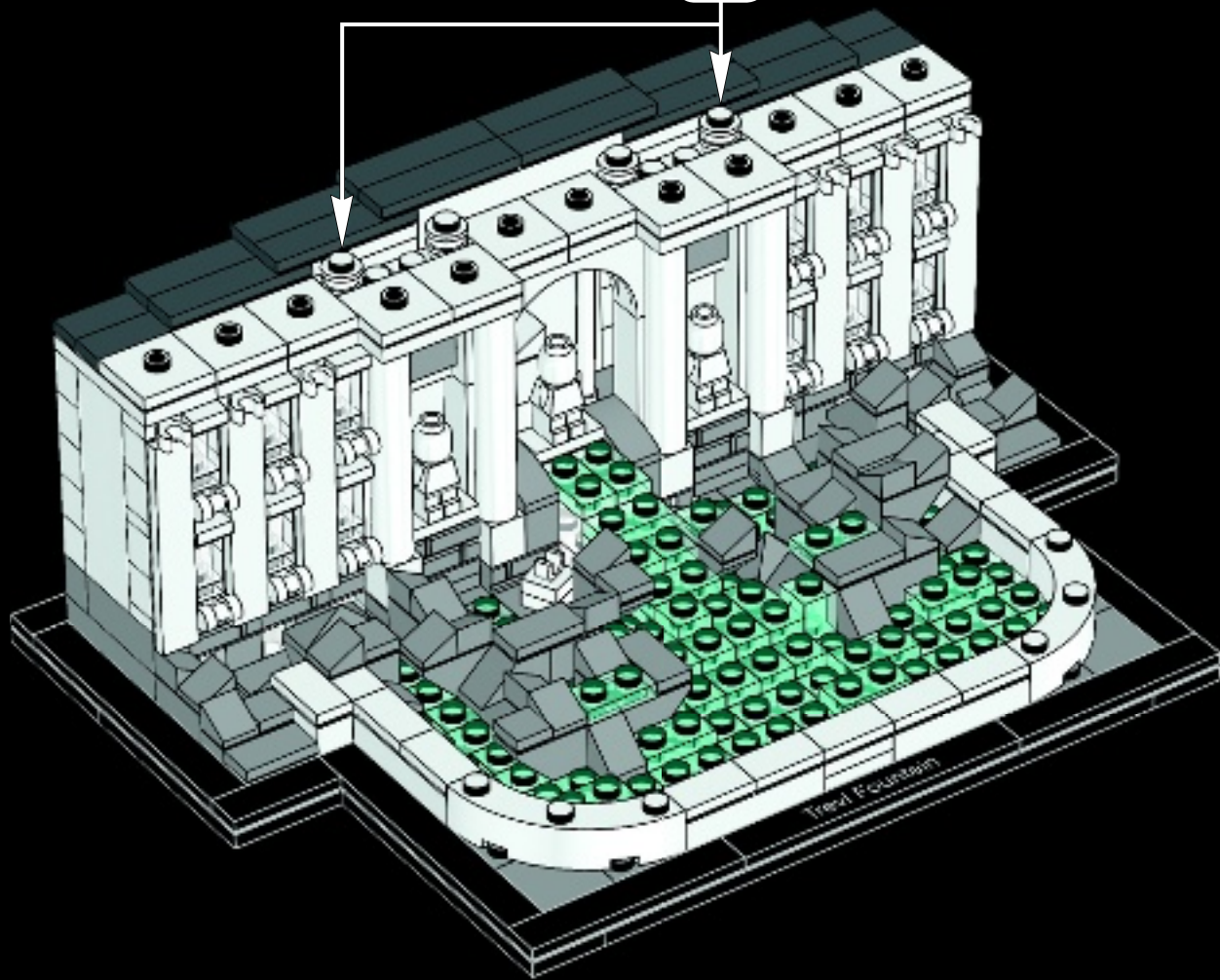



6x

86

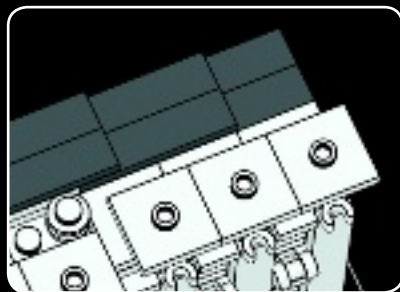



4x

87



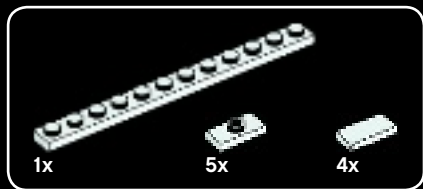

88

1

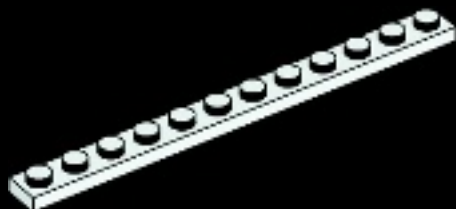

2

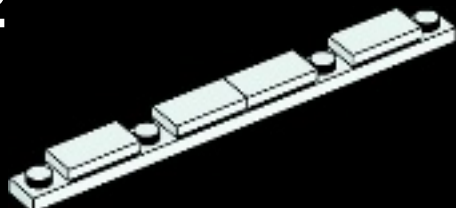

3

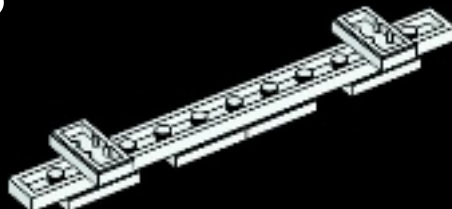
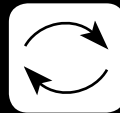

4

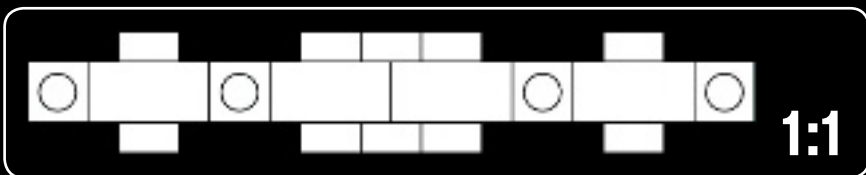
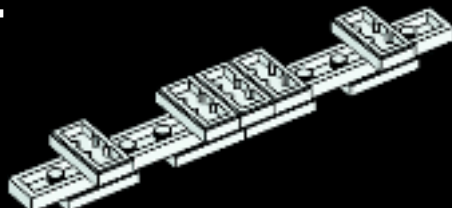

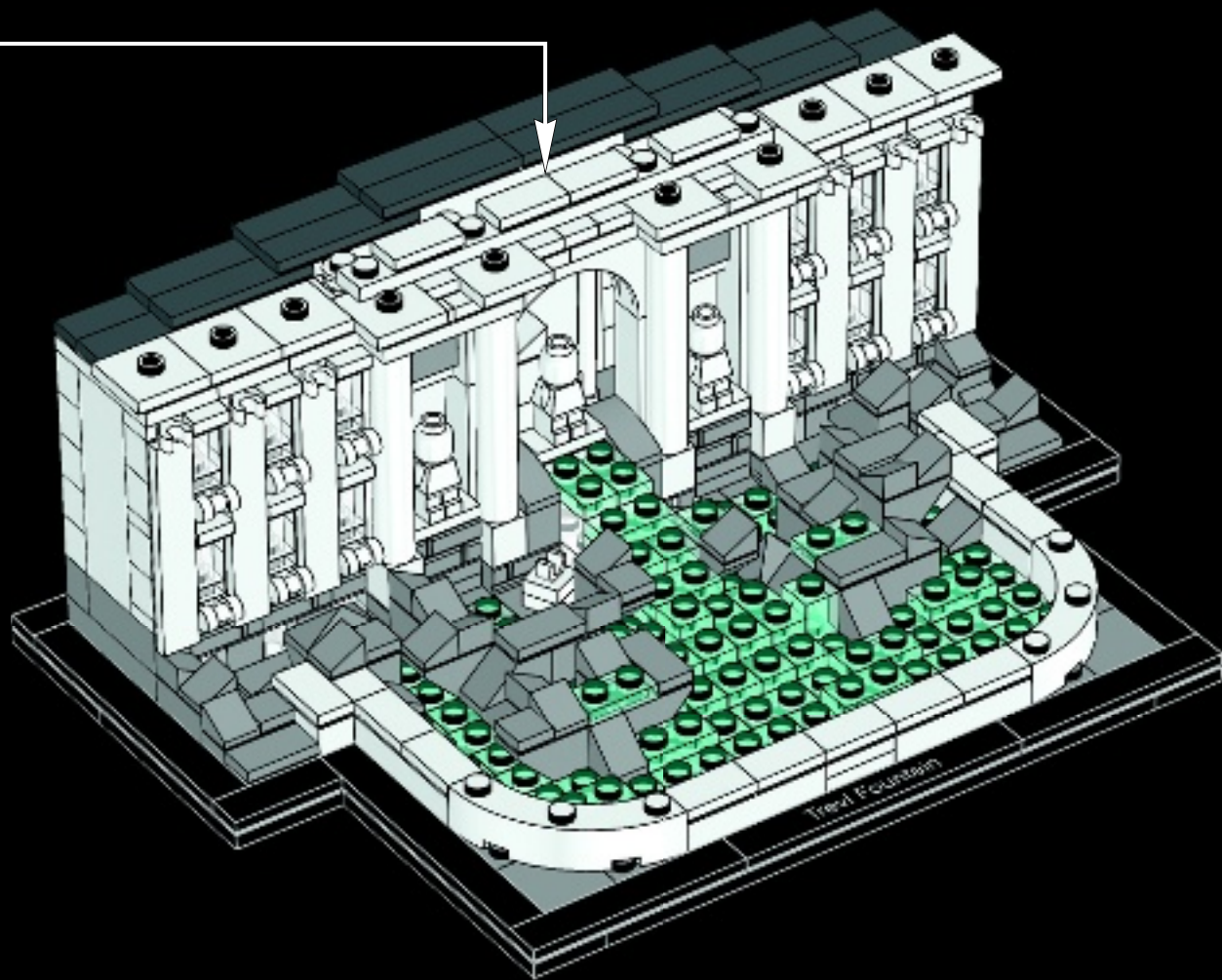

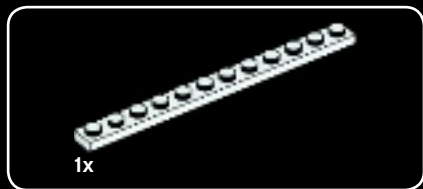

89





4x



1x

90

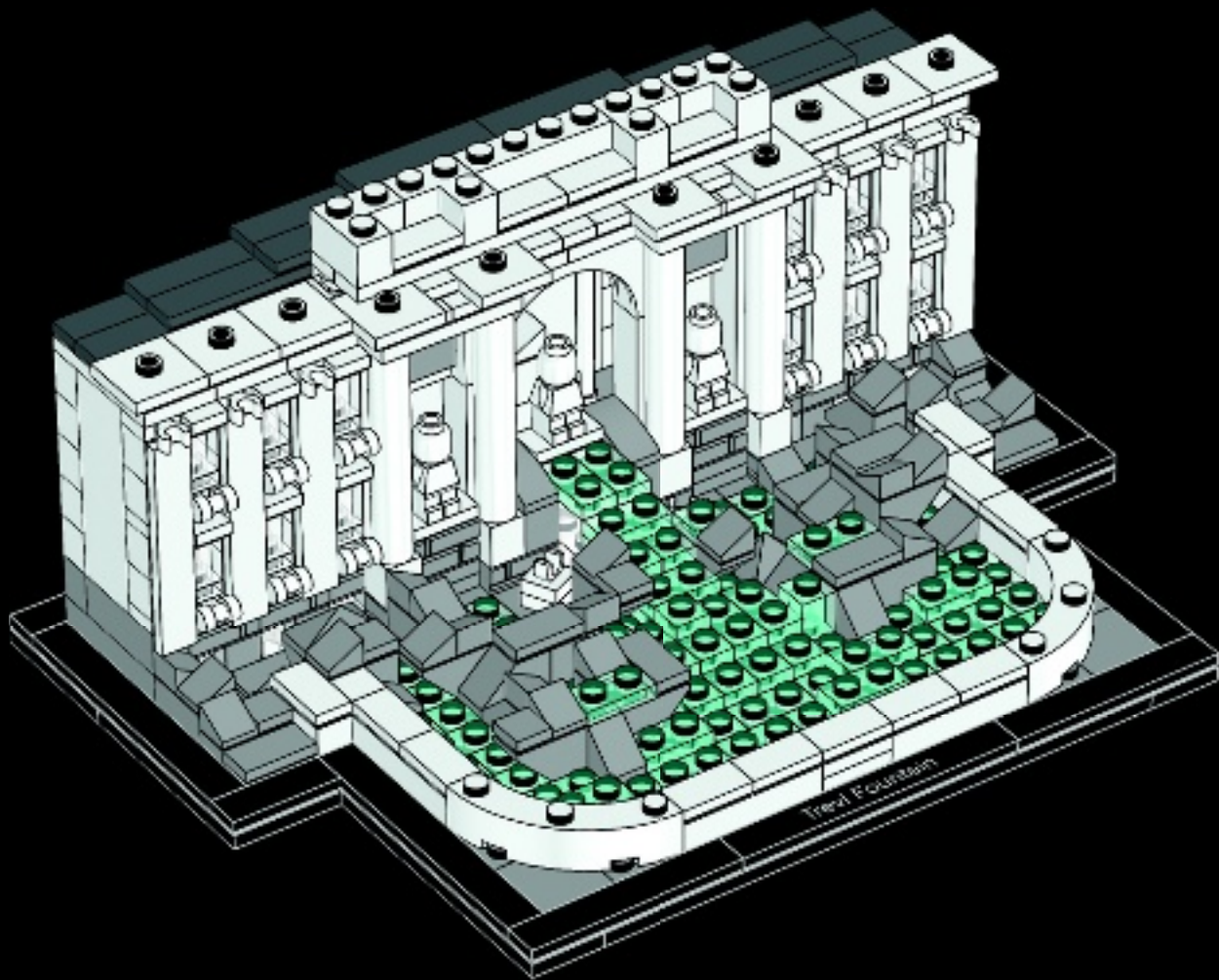



4x



4x

91

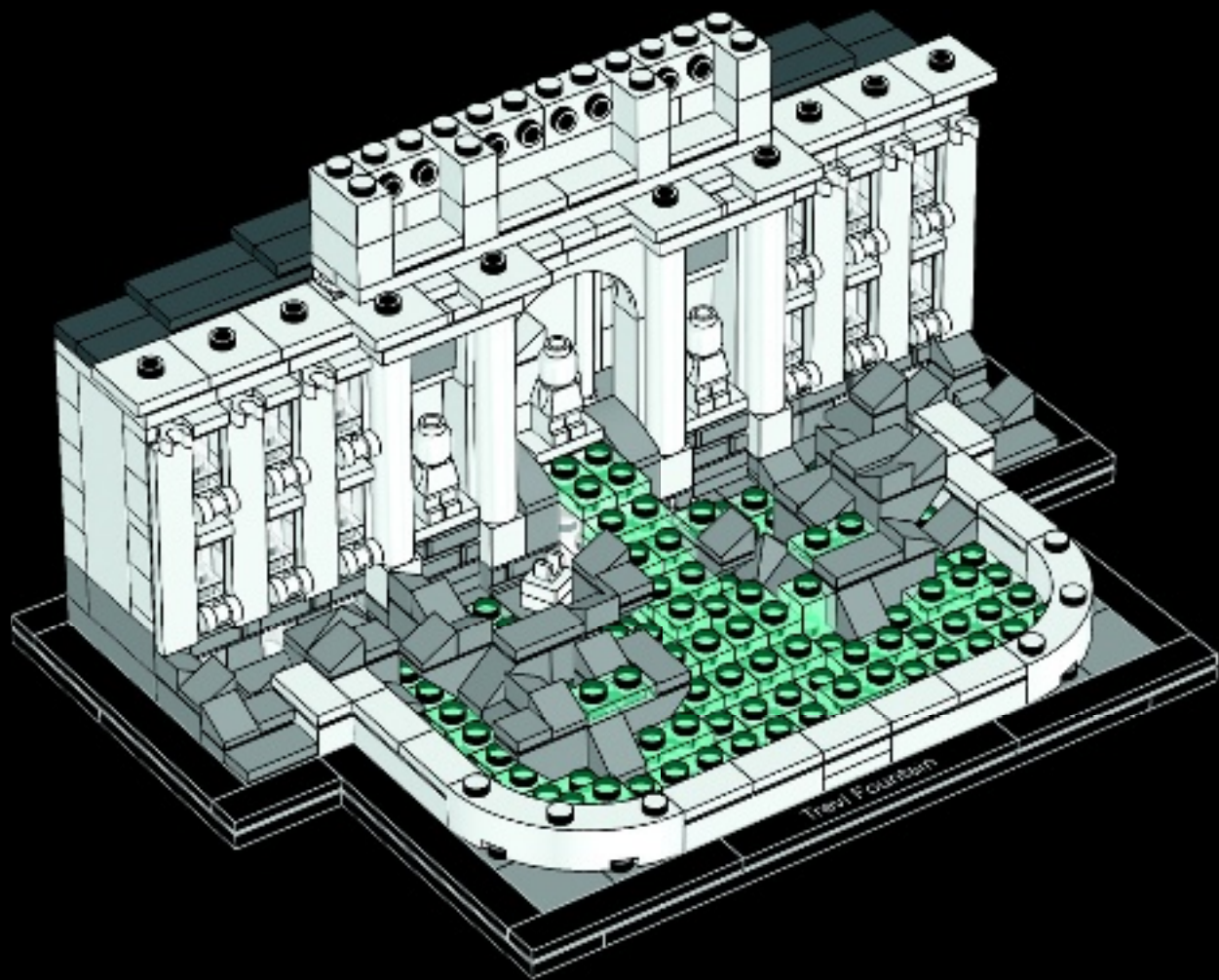

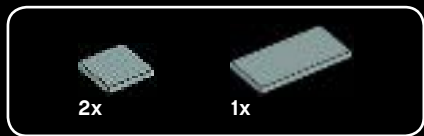

92

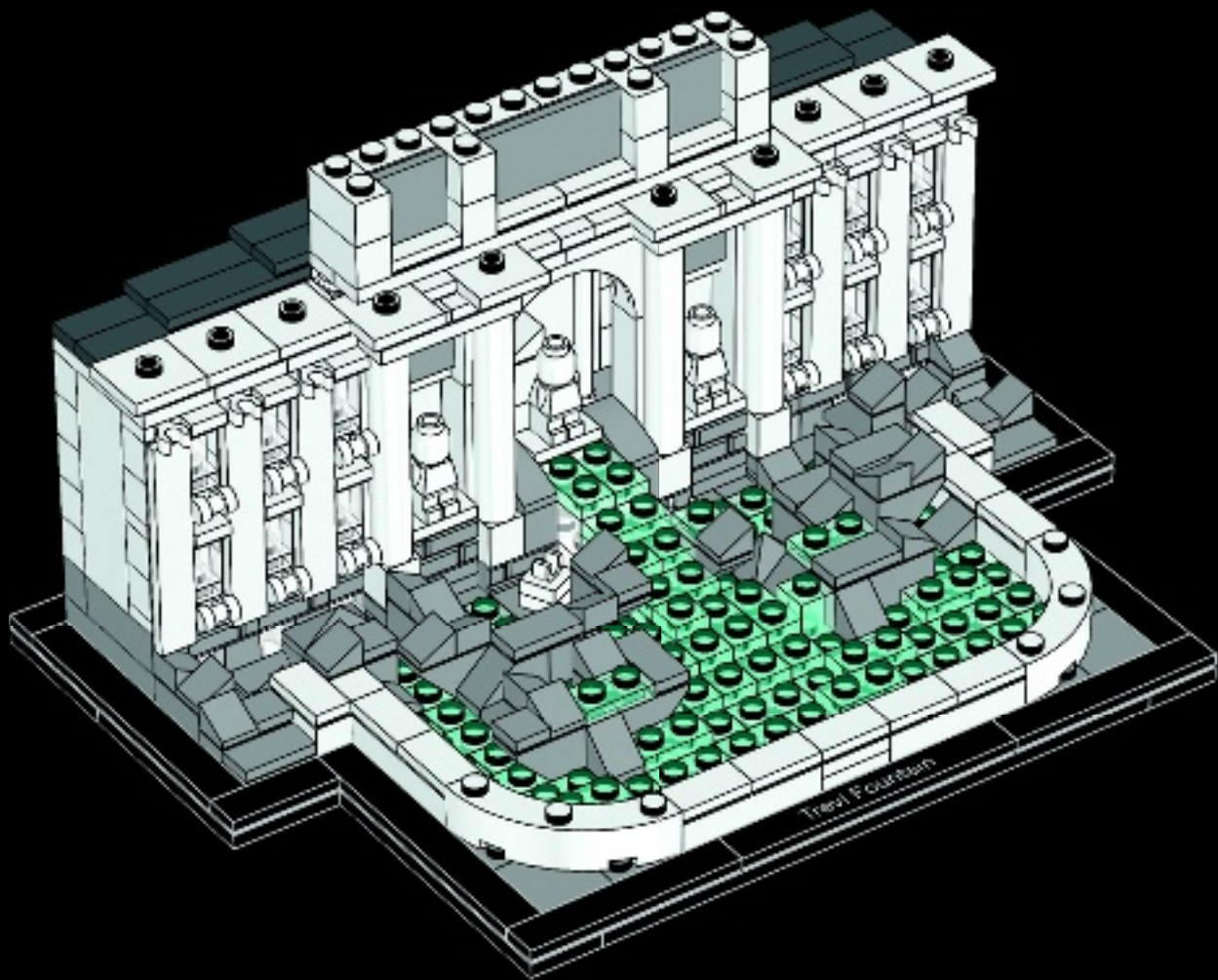



2x

93

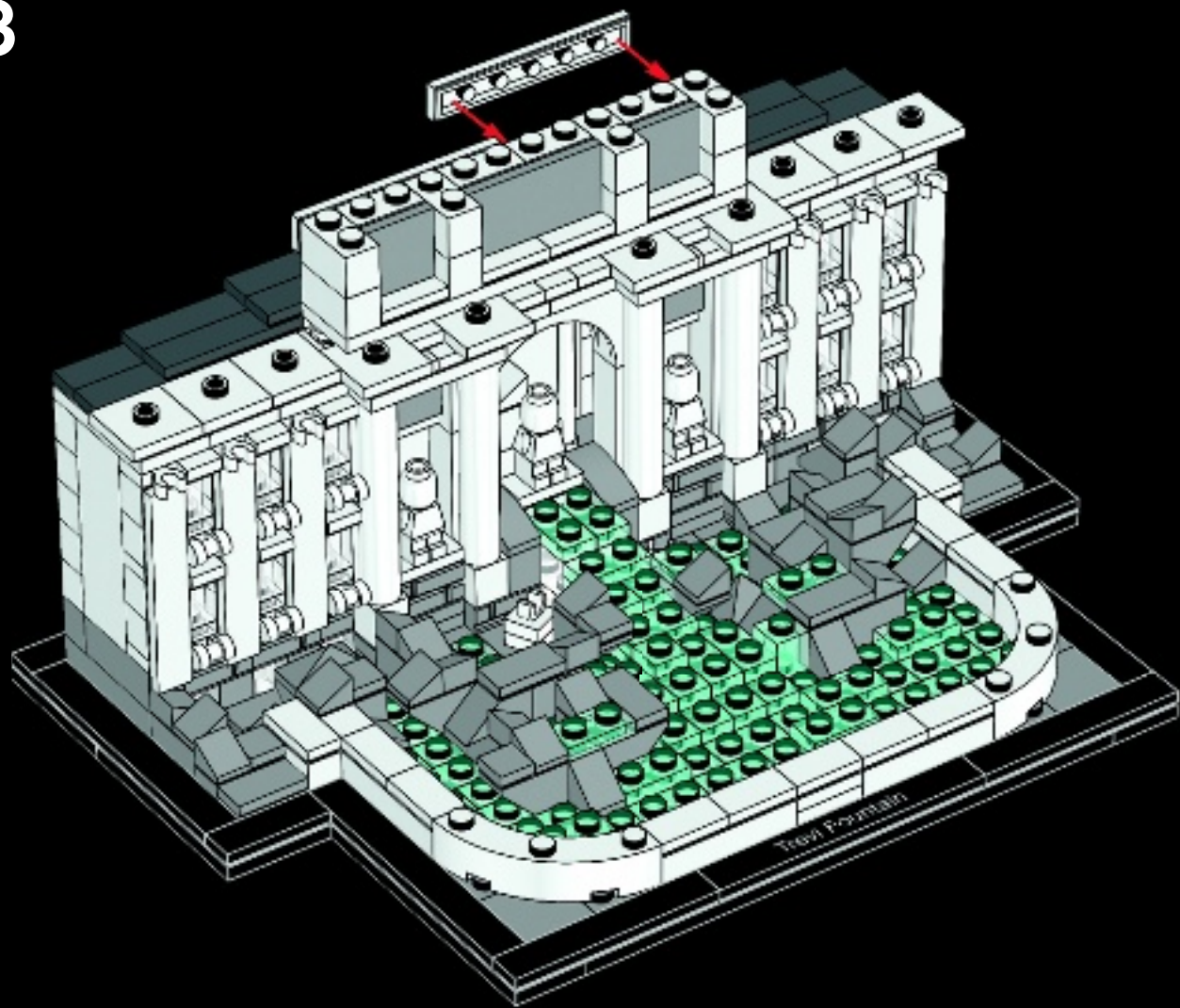

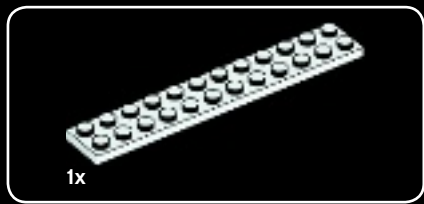

94

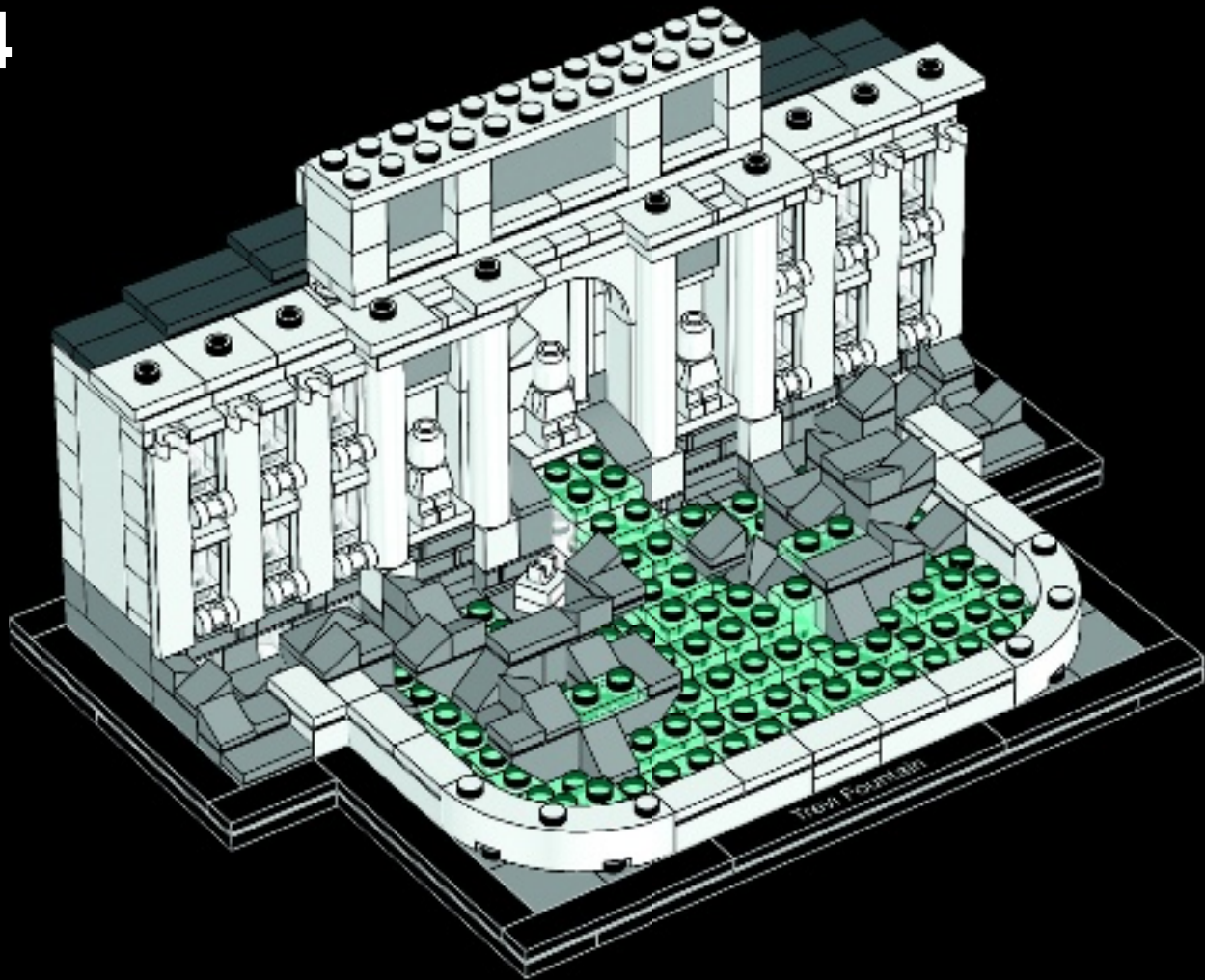



1x



6x

95





2x



2x



2x

96

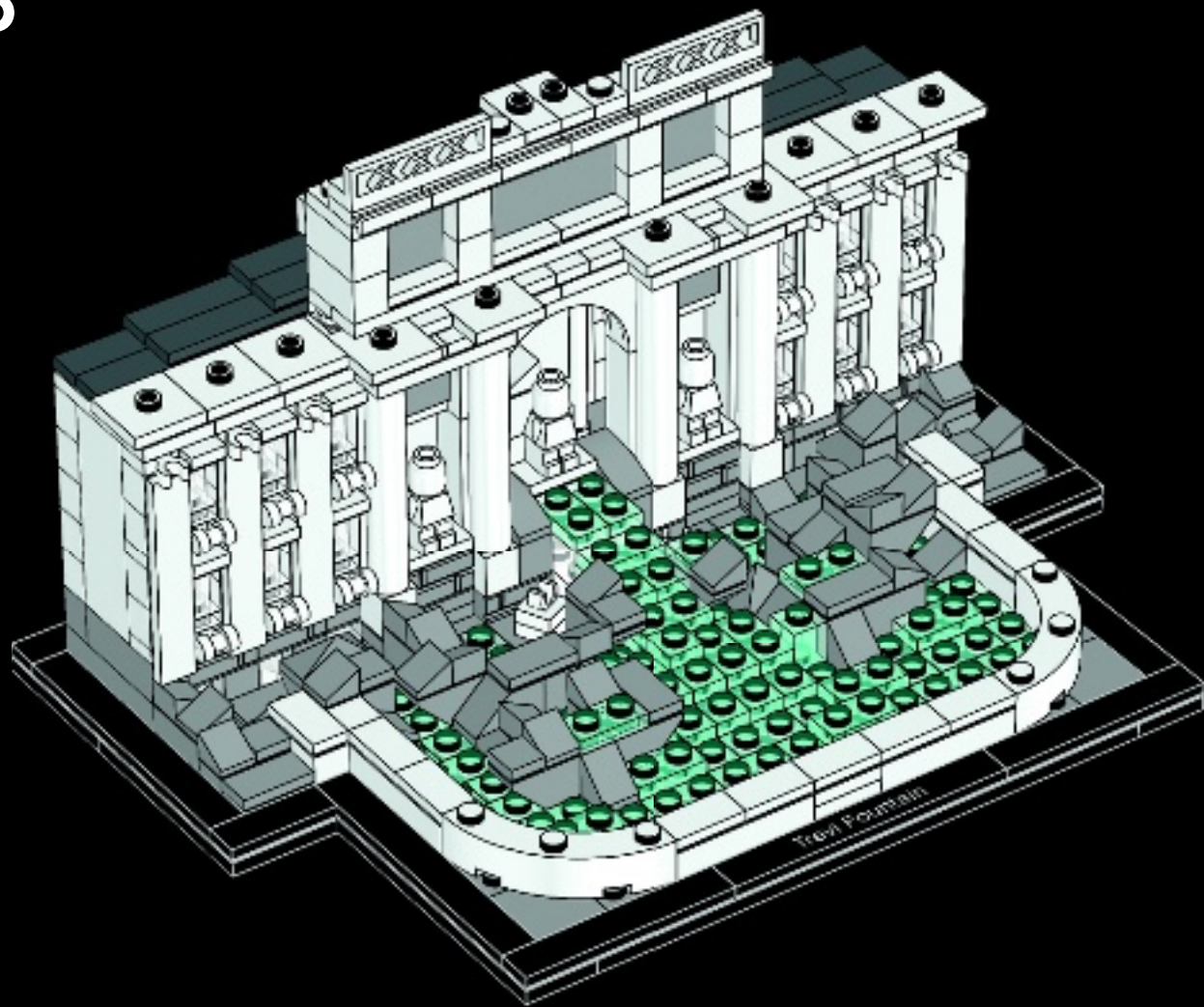

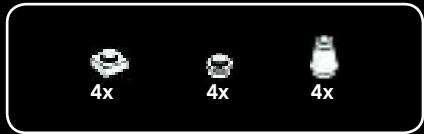

97

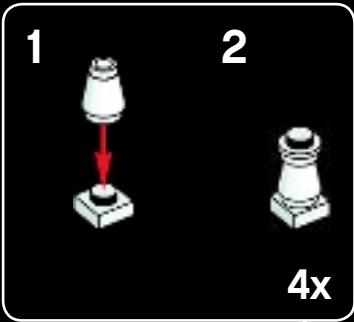

2



4x

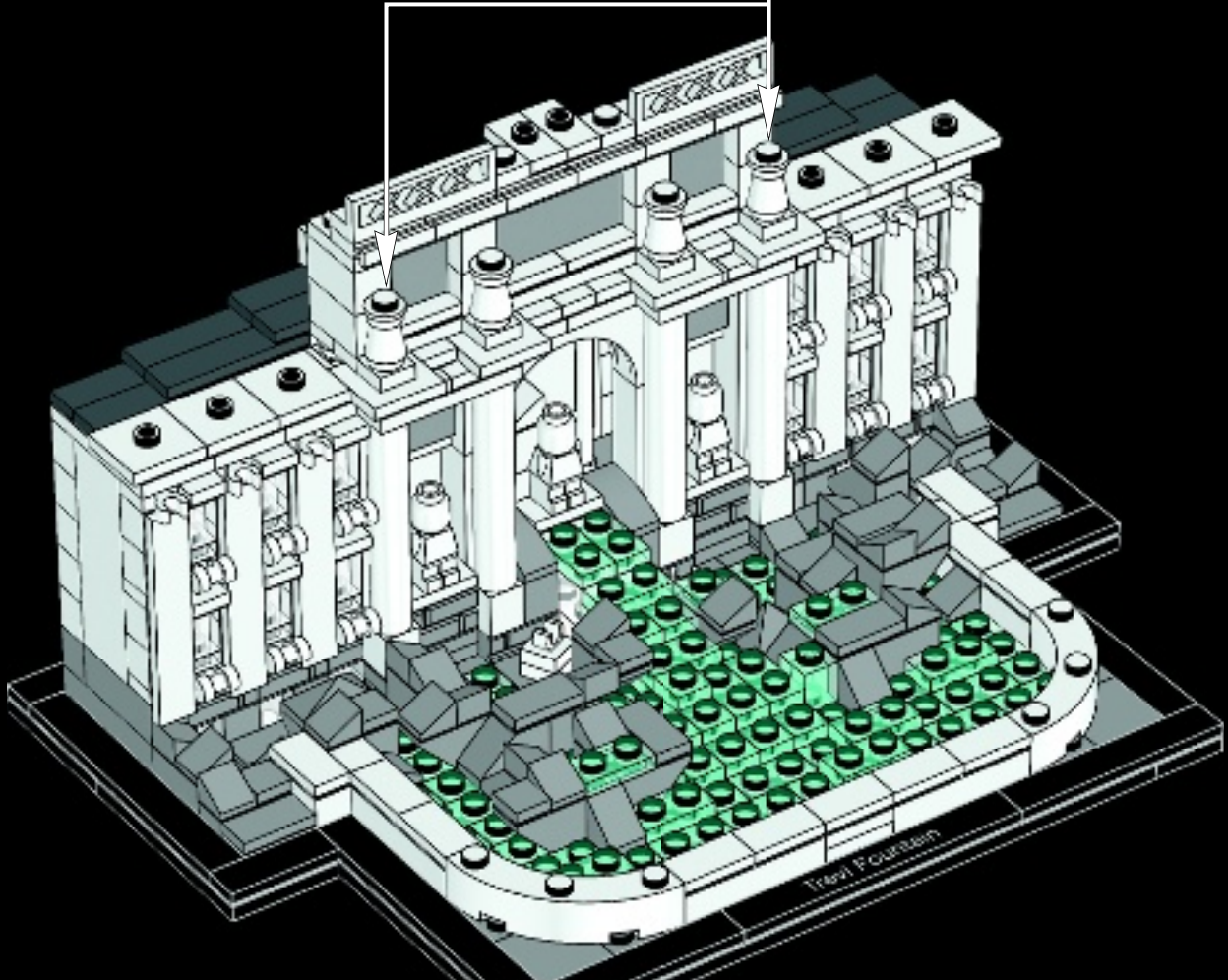



1

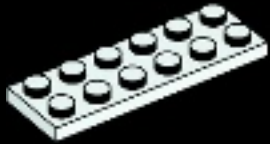

2

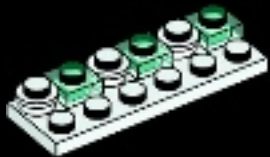

3

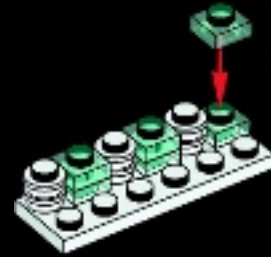

4





3x



3x

5



1x



3x

6



3x

7

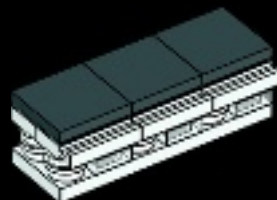

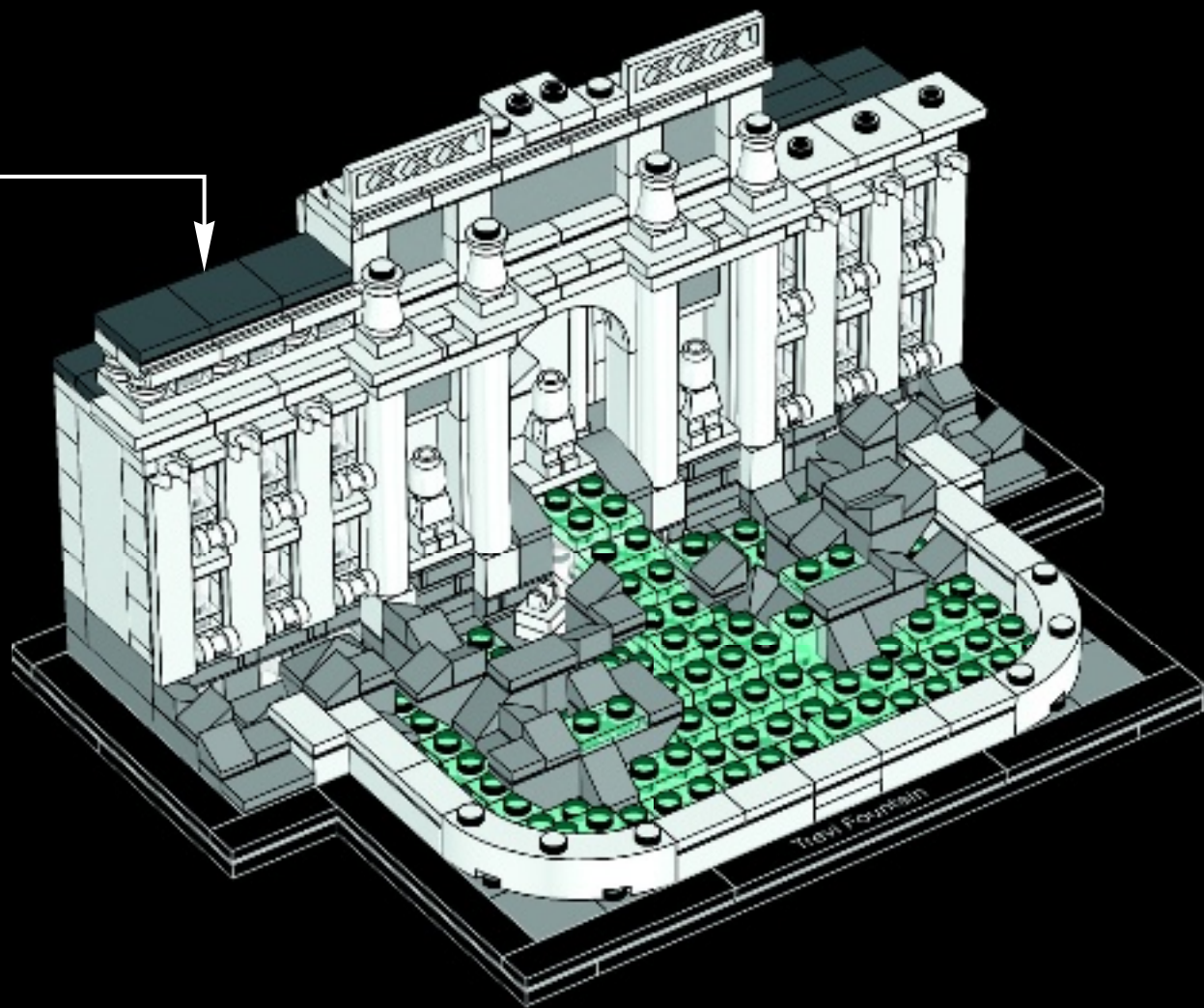



1



2

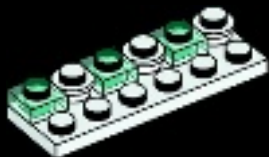

3

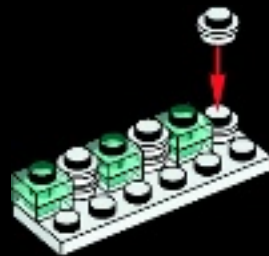

4



3x

3x

5



1x

3x

6



3x

7

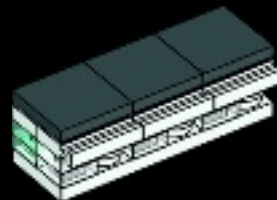





2x



2x



2x

100

1



2



2x



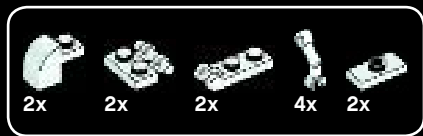

101

1



2



3



4

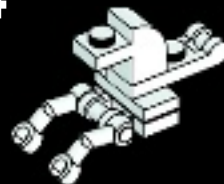

2x

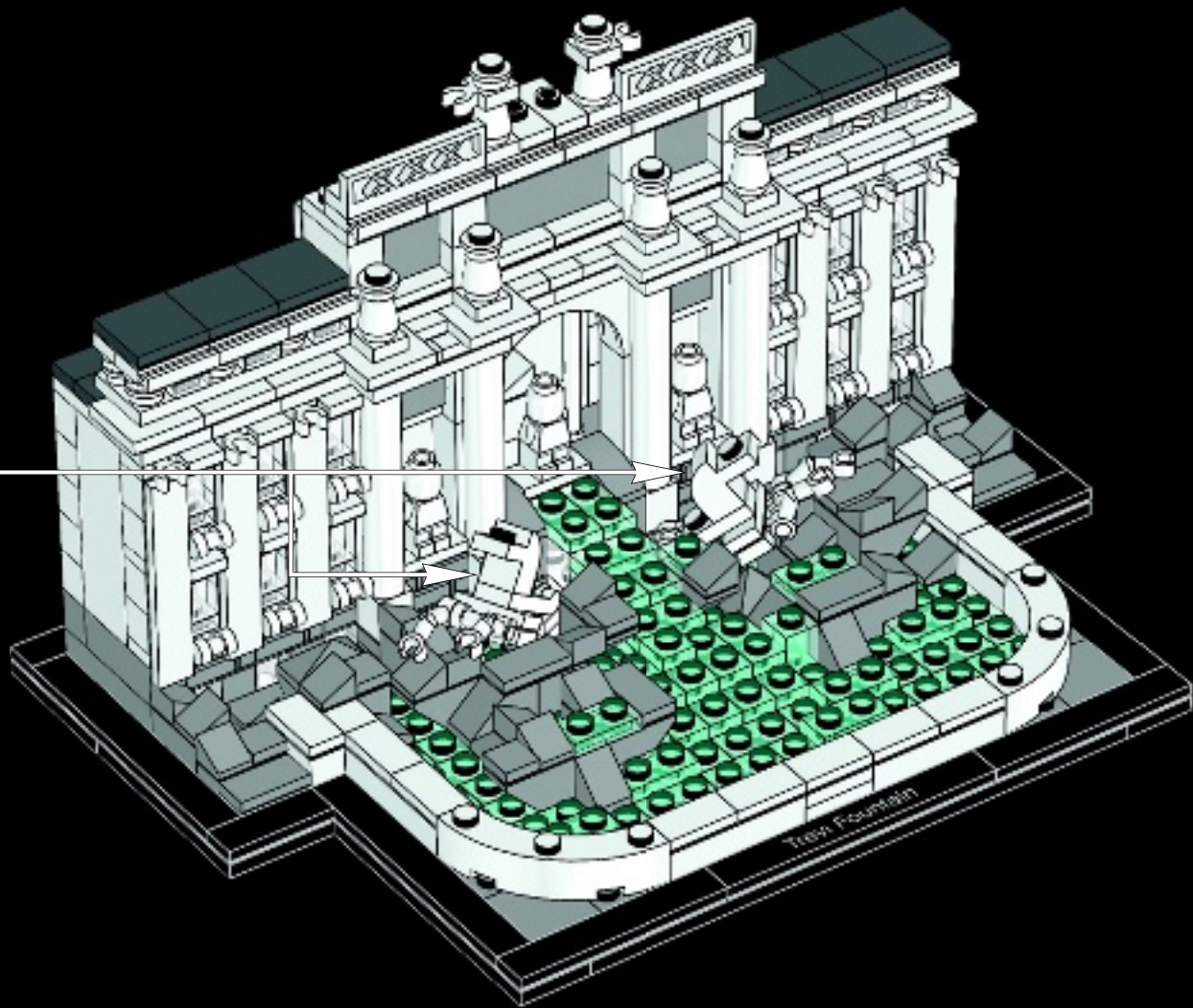

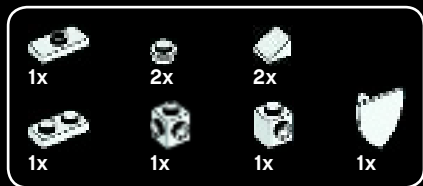

102

1

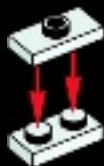

2



3



4



5



6





A Word from the Artist

LEGO® Trevi Fountain is based on a harmonious whole of four design features. First, serving as the backdrop, is the facade of the Palazzo Poli. At this small scale, some of its architectural elements, such as balustrades and balconettes, are abstracted by just one LEGO brick. In places where the scale doesn't allow for finer detail, a trick was used; on the otherwise monochromatic fountain and facade, certain elements are distinguished by color. The gray LEGO bricks represent the bas-reliefs above the statues and the inscription above the arch as well as the whole second design feature, the sea reef. Its gray rocks break the symmetry of the LEGO model, a task accomplished on the original fountain by sculptures. These are the third and most heavily abstracted design feature.

LEGO figures stand for the statues of *Oceanus*, *Abundance*, and *Salubrity*, or health; the four statues located above the engaged columns are represented by a small LEGO cone

topped with a 1x1 round plate. Two hippocampi at the base are made from just a few pieces and provide the illusion of movement, together with the fourth design feature, the water, made with transparent LEGO pieces.

Rok Kobe



Rok Žgalin Kobe

The Trevi Fountain model was created in close collaboration with the LEGO design team. They look at the model from a LEGO building point of view and ensure the construction process is simple and logical, and a positive experience for the user.

L'opinione dell'artista

La Fontana di Trevi LEGO® è basata su un insieme armonioso di quattro elementi progettuali. In primo luogo, la facciata di Palazzo Poli, che svolge la funzione di fondale. A causa della scala ridotta, alcuni dei suoi elementi architettonici, quali le balaustre e i balconcini, sono stati riprodotti con un solo mattoncino LEGO. Nei punti in cui la scala non consente dettagli più particolareggiati, abbiamo utilizzato una soluzione cromatica, anche se la fontana e la facciata in realtà sono monocromatiche. I mattoncini LEGO grigi rappresentano i bassorilievi sopra le statue e la scritta sovrastante l'arco, così come l'intero secondo elemento progettuale, la scogliera. Le sue rocce grigie spezzano la simmetria del modello LEGO, un espediente che nella fontana originale era stato conseguito tramite le sculture. E le sculture sono l'elemento architettonico più astratto dell'intero progetto.

Le statue di Oceano, dell'Abbondanza e della Salubrità sono state riprodotte con figure LEGO; le quattro statue sopra le quattro colonne principali sono state invece realizzate con l'ausilio di piccoli coni LEGO e una piastra

rotonda di 1x1. I due cavalli alati alla base sono stati riprodotti con pochi pezzi per dare l'illusione del movimento, insieme al quarto elemento progettuale, l'acqua, realizzata con pezzi LEGO trasparenti.

Rok Kobe



Rok Žgalin Kobe

Il modello della Fontana di Trevi è stato realizzato in stretta collaborazione con il team di progettazione LEGO. Il team approccia il modello dal punto di vista della costruzione LEGO, assicurando che il processo sia semplice e logico e sia un'esperienza positiva per l'utente.

The “Scale Model” Line – LEGO® Architecture in the 1960s

The history of the current LEGO® Architecture Series can be traced back to the beginning of the 1960s, when the popularity of the LEGO brick was steadily increasing. Godtfred Kirk Christiansen, the then owner of the company, began looking for ways to further expand the LEGO system and asked his designers to come up with a set of components that would add a new dimension to LEGO building.

Their answer was as simple as it was revolutionary: five elements that matched the existing bricks, but were only one-third the height. These new building “plates” made it possible to construct more detailed models than before.

This greater LEGO flexibility seemed to match the spirit of the age; modernist architects were redefining how houses looked and people were taking an active interest in the design of their new homes. It was these trends that led to the introduction of the LEGO “Scale Model” Line in early 1962. The name itself was a direct link to the way

architects and engineers worked, and it was hoped that they and others would build their projects “to scale” in LEGO elements. As with LEGO Architecture today, the original sets were designed to be different from the normal, brightly colored LEGO boxes, and also included “An Architectural Book” for inspiration.

Although the five elements remain an integral part of the LEGO building system today, the “Scale Model” Line was phased out in 1965. Many of the principles from the series would re-emerge over 40 years later in the LEGO Architecture Series.



La linea “Scale Model” – LEGO® Architecture negli anni '60

La storia della corrente serie di LEGO® Architecture può essere fatta risalire agli inizi degli anni '60, quando la popolarità del mattoncino LEGO era in costante aumento. Godtfred Kirk Christiansen, l'allora proprietario della società, stava ricercando nuovi metodi per ampliare ulteriormente il sistema LEGO e chiese ai suoi designer di ideare una serie di componenti che aggiungessero una dimensione originale alle costruzioni LEGO.

La loro risposta fu tanto semplice quanto rivoluzionaria: cinque elementi che riprendevano il concetto dei mattoncini esistenti, ma alti solo un terzo. Queste nuove piattaforme di costruzione consentirono di realizzare modelli più dettagliati.

Questa maggiore flessibilità in LEGO era senza dubbio al passo con i tempi: gli architetti modernisti stavano infatti ridefinendo il concetto di edificio e le persone cominciarono a interessarsi attivamente al design delle loro nuove abitazioni. Furono proprio queste tendenze che portarono all'introduzione della linea LEGO “Scale Model” all'inizio del 1962. Il

nome in sé era un collegamento diretto con il modo in cui architetti e ingegneri lavoravano e si sperava che anche altri avrebbero seguito il loro esempio, realizzando modelli in scala con gli elementi LEGO. Così come con LEGO Architecture oggi, i set originali furono progettati per essere diversi dalle solite coloratissime confezioni LEGO e comprendevano anche 'Un Libro di architettura', con idee ispiratrici.

Sebbene i cinque elementi siano ancora una parte integrante del sistema di costruzione LEGO, la linea “Scale Model” fu messa fuori produzione nel 1965. Molti dei suoi principi sarebbero stati ripresi 40 anni più tardi, nella serie LEGO Architecture.



Architect Series

Serie Architect

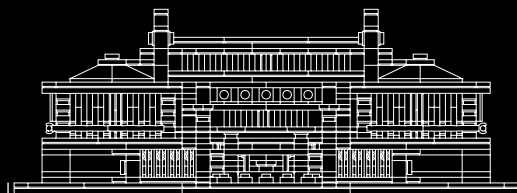

21017
Imperial Hotel

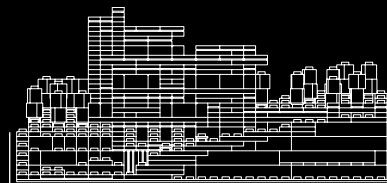

21005
Fallingwater®



21012
Sydney Opera House™

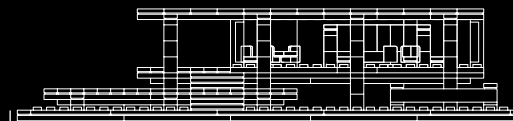

21009
Farnsworth House™

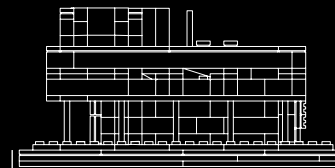

21014
Villa Savoye

Landmark Series

Serie Landmark

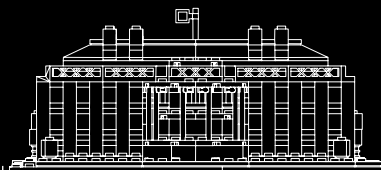

21006
The White House

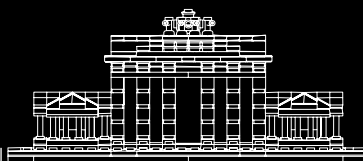

21011
Brandenburg Gate

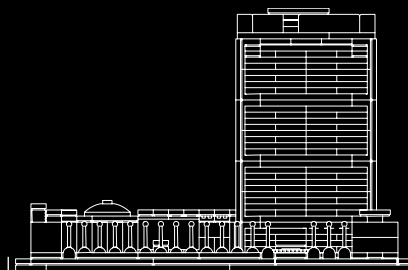

21018
United Nations Headquarters

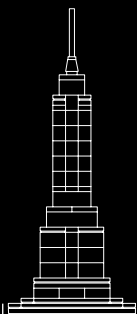

21002
Empire State Building

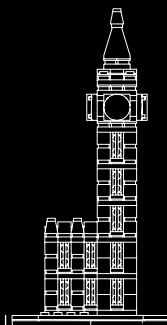

21013
Big Ben



21003
Seattle
Space Needle

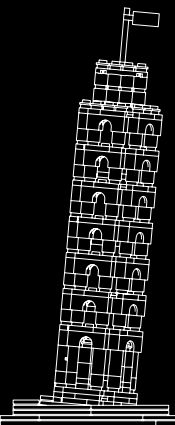

21015
The Leaning Tower
of Pisa

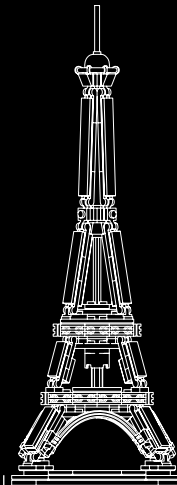

21019
Eiffel Tower

References

Text

www.trevifountain.net

www.wikipedia.org

Photography -

www.shutterstock.com

Customer Service
Kundenservice
Service Consommateurs
Servicio Al Consumidor
LEGO.com/service or dial

Ringraziamenti

Testo

www.trevifountain.net

www.wikipedia.org

Fotografia -

www.shutterstock.com

Assistenza clienti
Kundenservice
Service Consommateurs
Servicio Al Consumidor
LEGO.com/service o chiamare il numero

Customer Service
Kundenservice
Service Consommateurs
Servicio Al Consumidor
LEGO.com/service or dial



00800 5346 5555 :

1-800-422-5346 :

