

**LEGO**

**GH**OST**BUSTERS**



**BUILDING INSTRUCTIONS**

# WHO YOU GONNA CALL?

In the early 1980s an inspired film concept was born — unleash an ultimate supernatural power on the city of New York and call upon the best comedic talent in Hollywood to save the day. Then, throw in great special effects and a talented director. Next comes the blockbuster film that audiences have loved for thirty years *Ghostbusters!*



When strange paranormal incidents began occurring at Columbia University, the Paranormal Studies Department began to investigate. Despite their findings, Dr. Peter Venkman, Dr. Ray Stantz, and Dr. Egon Spengler lost their funding and were thrown out. They regrouped and formed a paranormal detection and elimination service called *Ghostbusters*. Ray purchased an old ambulance that was transformed into their ghost-busting vehicle, the *Ecto-1*. Their first assignment called on them to remove Slimer, a gluttonous apparition from the Sedgwick Hotel. After successfully completing the job, the team continued their work and their business grew, so they hired another team member, Winston Zeddemore.



All four of them were put to the ultimate test when they had to save New York from Zuul, a paranormal powerhouse. Just when their battle seemed lost, the Ghostbusters made a daring decision to cross the particle streams from their proton packs which resulted in a catastrophic explosion that incinerated the giant

Mr. Stay Puft Marshmallow man and destroyed Zuul. Luckily the team survived the blast and the Ghostbusters received praise for saving the city.



*"If there's a steady paycheck in it,  
I'll believe anything you say."*



*"Back off, man, I'm a scientist."*



*"Listen! Do you smell something?"*



*"I collect spores, molds,  
and fungus."*

# MADE FOR GHOSTBUSTERS

The *Ecto-1* was a 1959 professional ambulance converted into the famous *Ecto-1* for the 1984 *Ghostbusters* film. The original design of the *Ecto-1* was an all-black vehicle with flashing purple and white strobe lights. The ghost-busting machine resembled a hearse instead of an ambulance. During production, the filmmakers realized the majority of the scenes took place at night so a dark car would be lost onscreen. For better visibility on the dark streets of New York, they decided the *Ectomobile* should be all white with red trim. The original script for *Ghostbusters* was more

of a fantasy film set in the future so the *Ectomobile* could dematerialize among other things. When the film was set in reality, the fantasy functions of the car were eliminated, and the humor was derived from a team riding in a beat-up old ambulance that barely ran. Today, the *Ecto-1* remains one of the most iconic movie cars of all time.

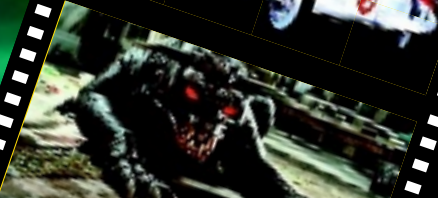





GH**OS**TBUSTERS.



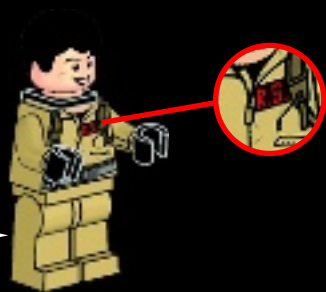
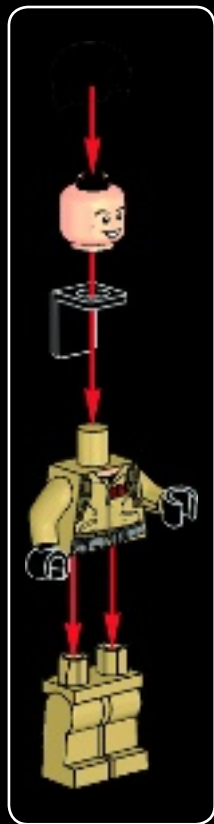

Ray



EGON

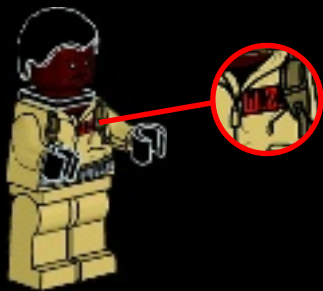

Winston

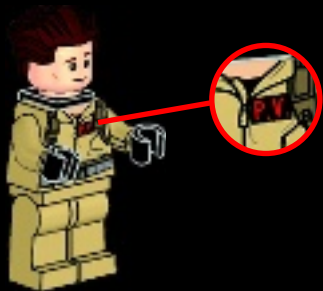

PETER



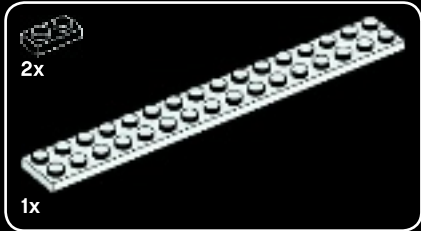

1

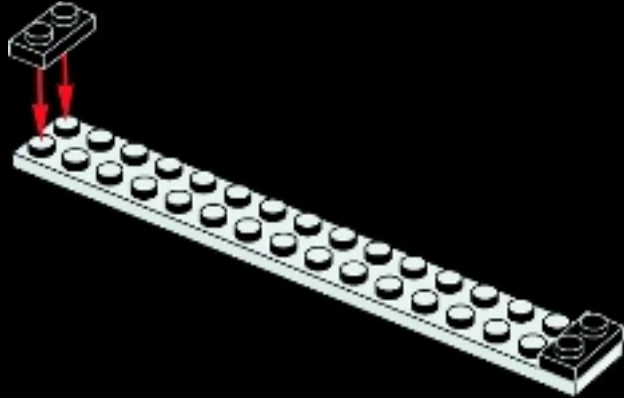

"Somebody blows their nose and you want to keep it?"

VENKMAN





1x



6x



6x

2

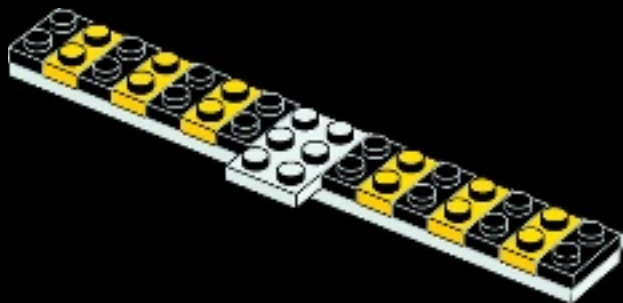

2x



8x



3x

3

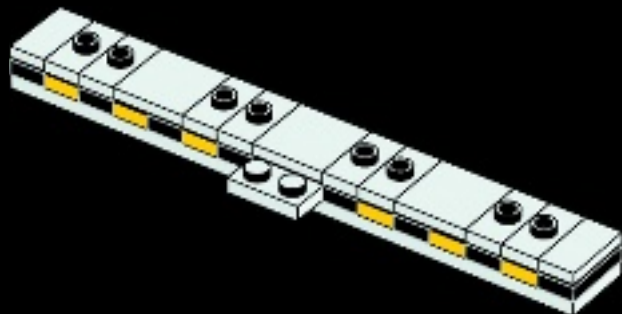



2x



1x

4

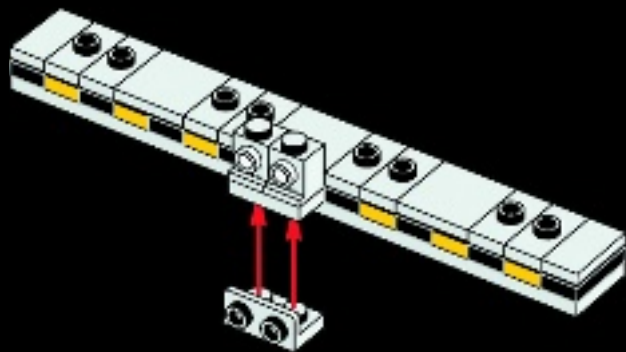

1x

5

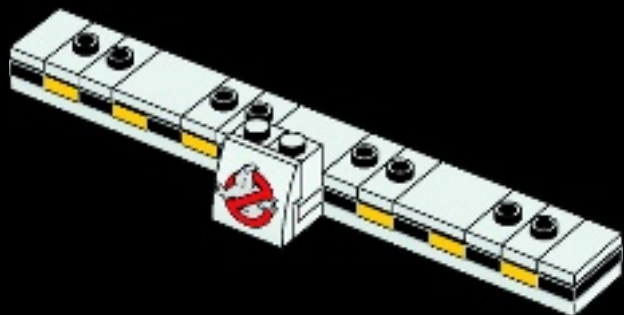

6

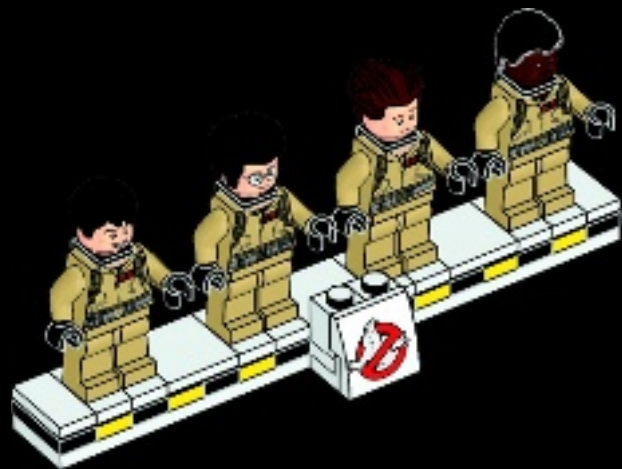



4x



2x

1

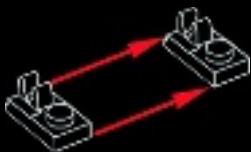

1x

2



"I collect spores, molds, and fungus"

SPENGLER

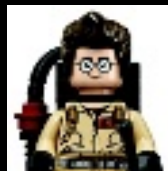





3

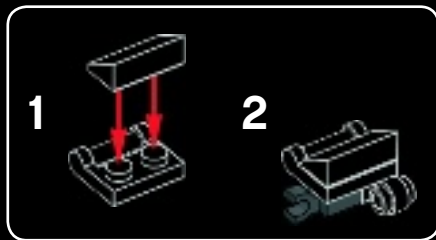



1x

4



1x

5





6

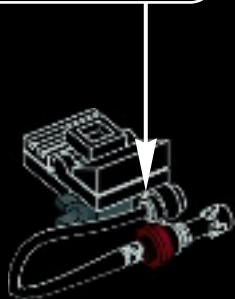

7



4x

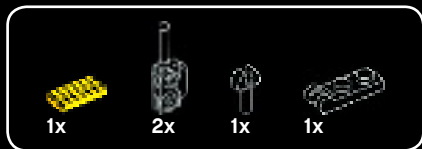

8

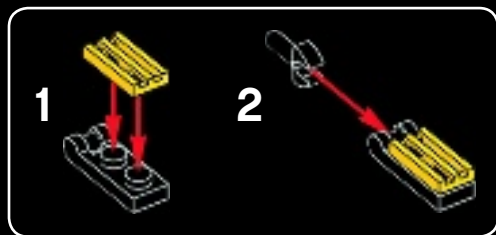

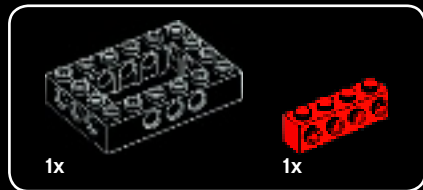
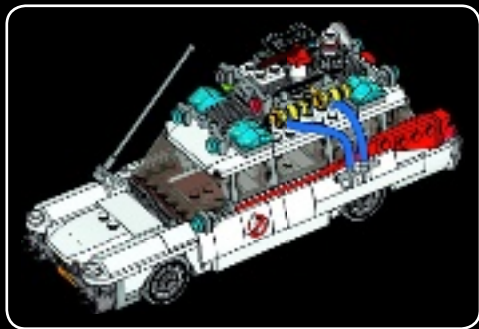

2

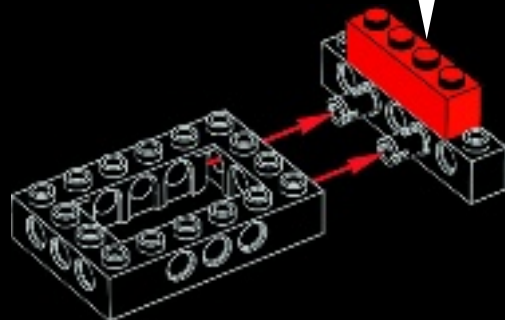





4x

3



2x

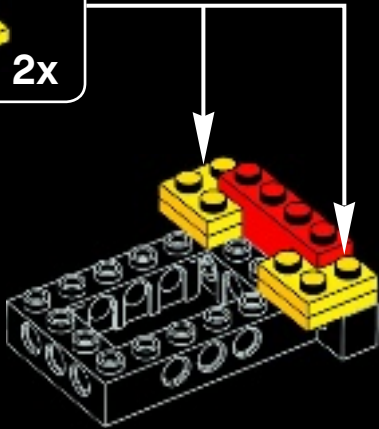

VENKMAN

"Twenty-four hours a day, seven days a week,  
no job is too big, no fee is too big!"



2x

4

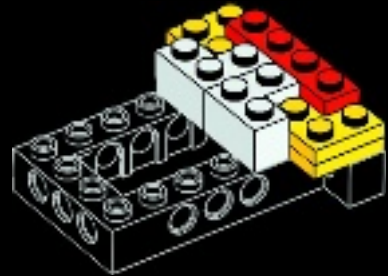



5

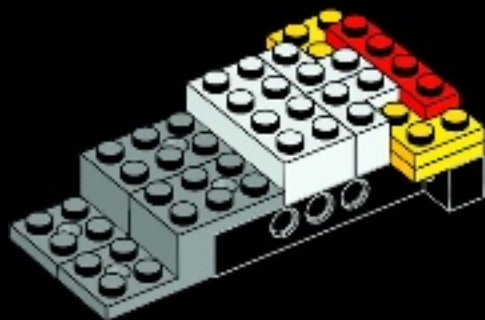

6

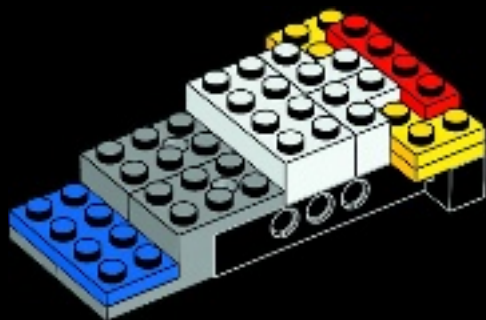

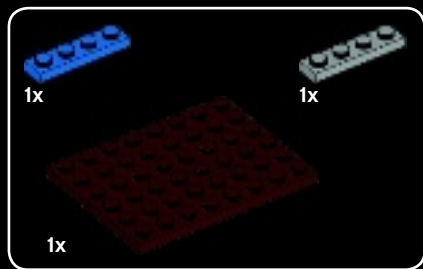

7

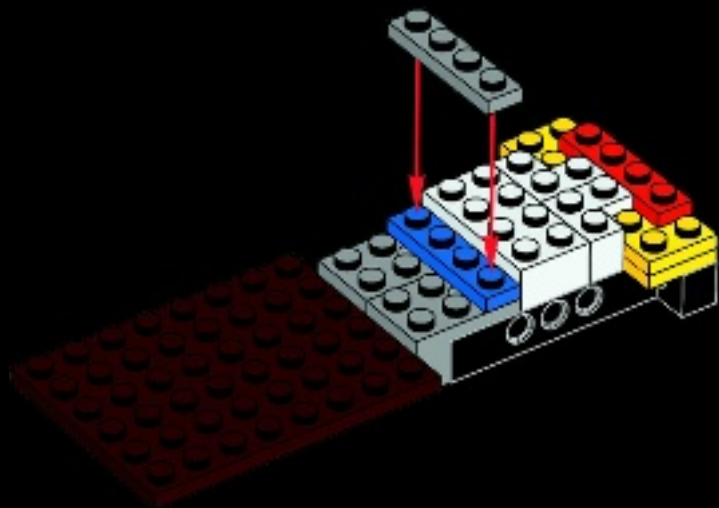

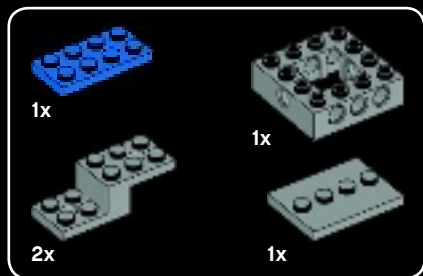

8

1



2



3

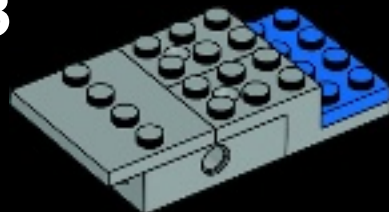

STANTZ

"Are you troubled by strange noises in the middle of the night?"

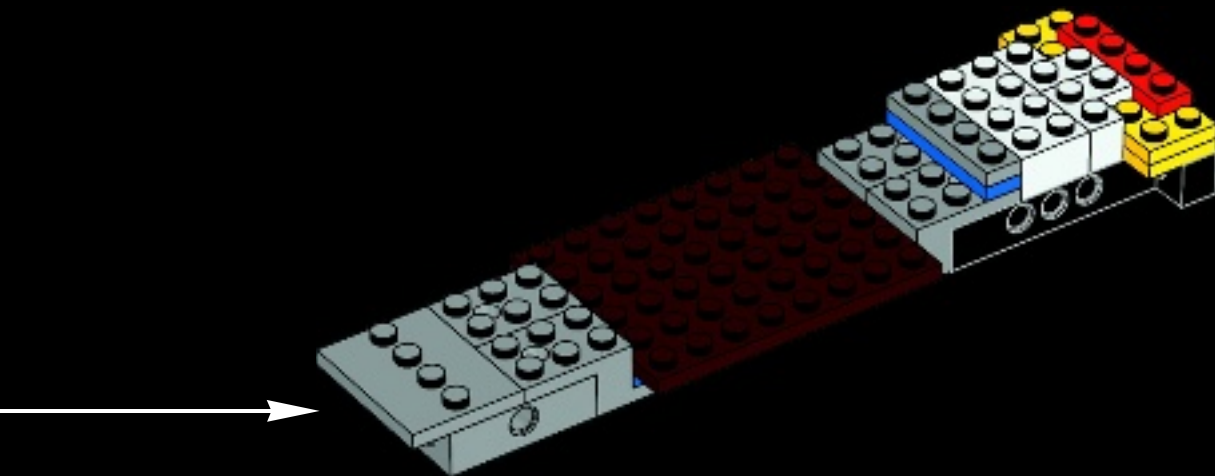
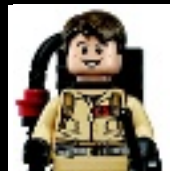



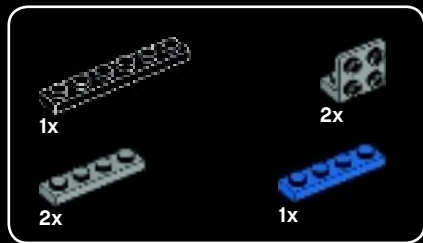

9

1

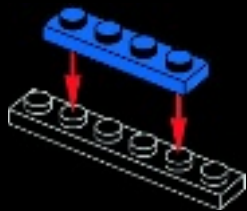

2

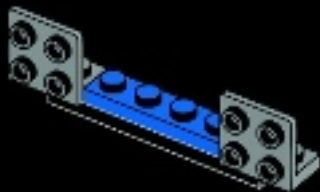

3

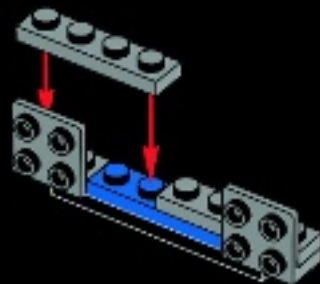

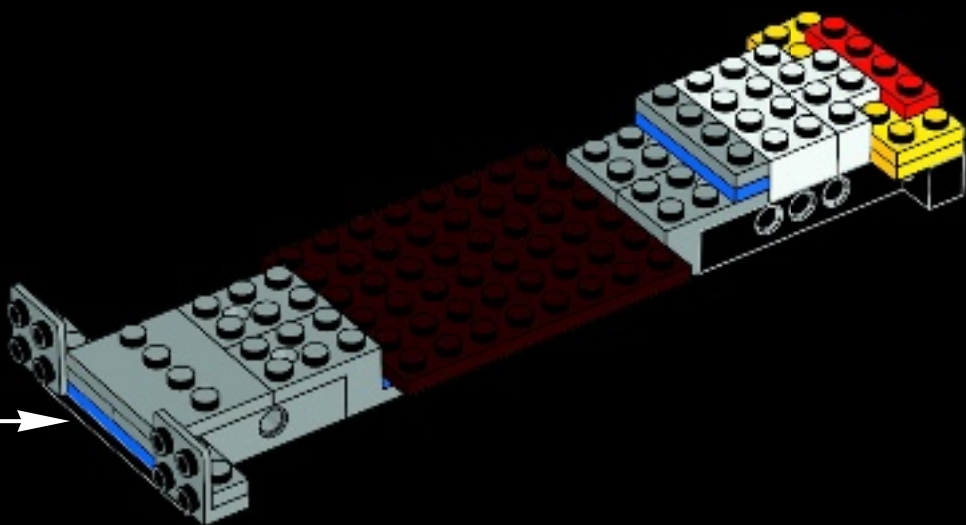



2x



2x

# 10

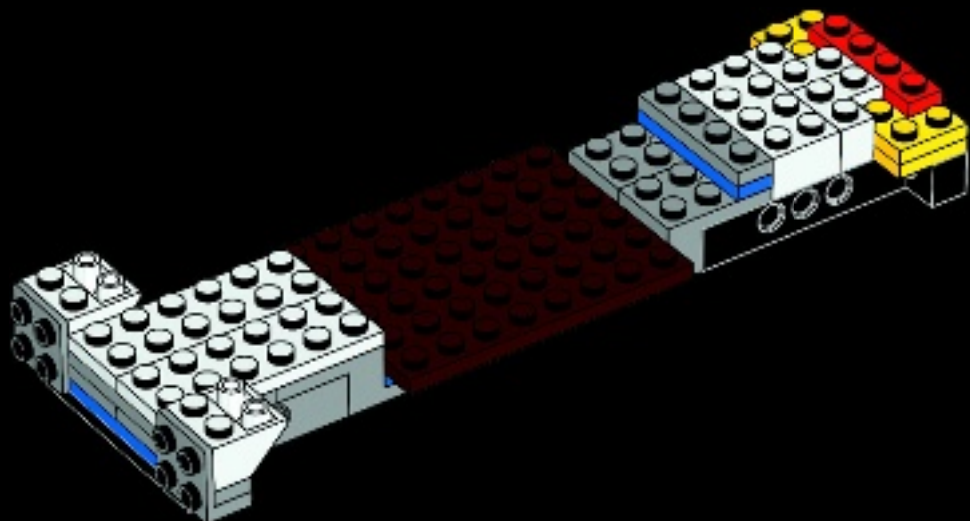



2x



1x

# 11

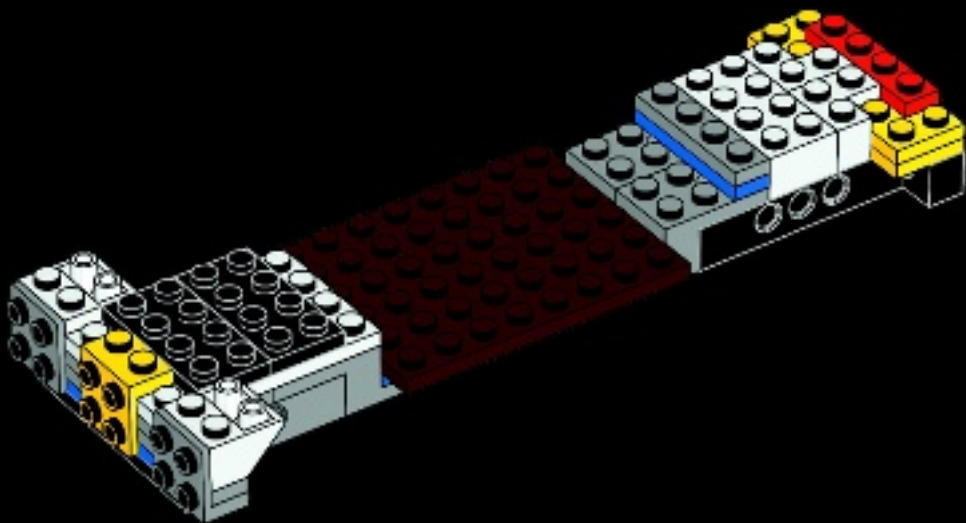

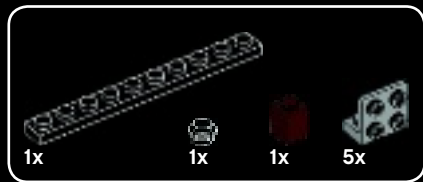

12

1



2

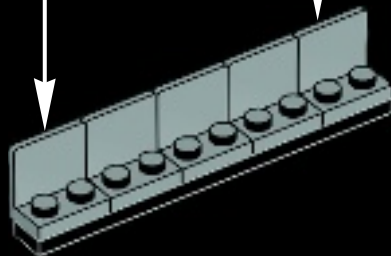

3

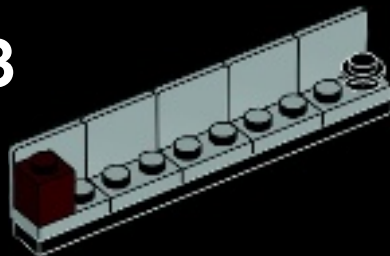



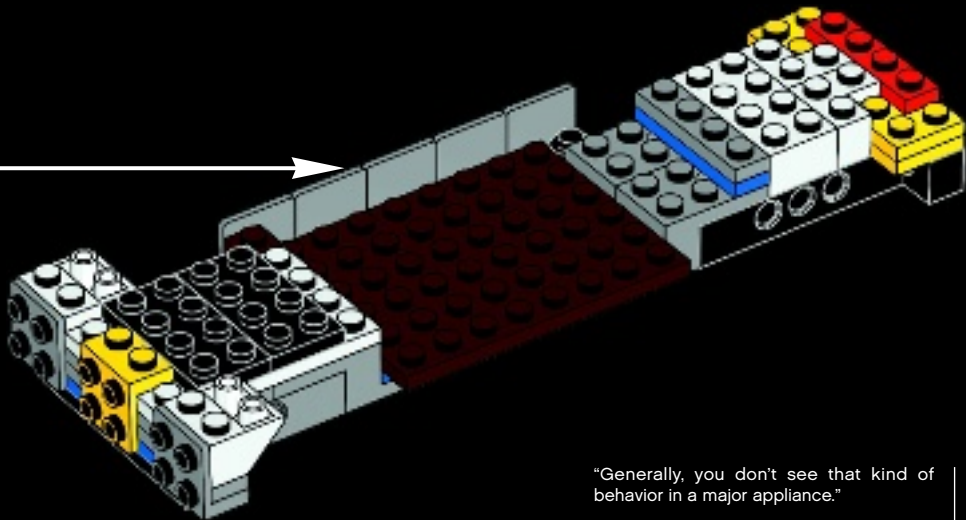

"Generally, you don't see that kind of behavior in a major appliance."

VENKMAN

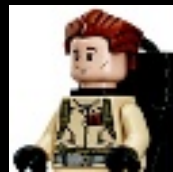

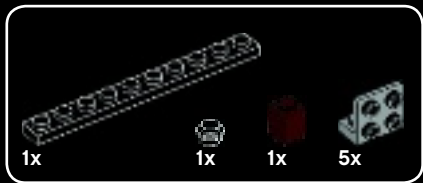

13



1



2

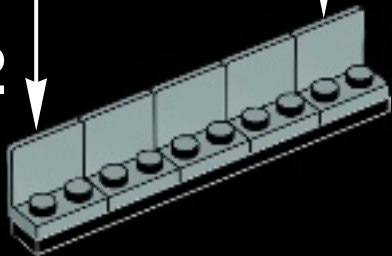

3

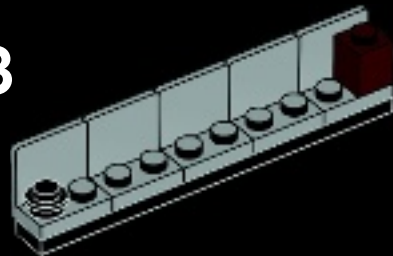

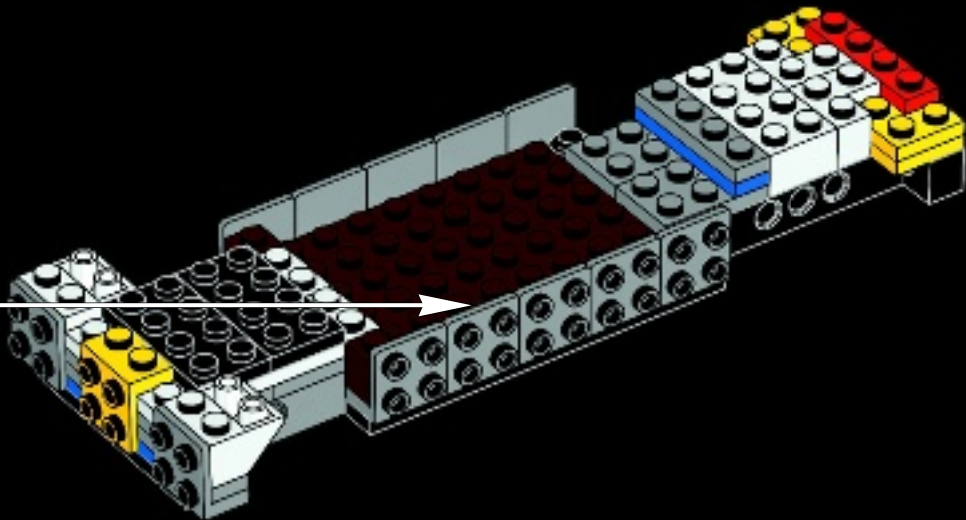



14

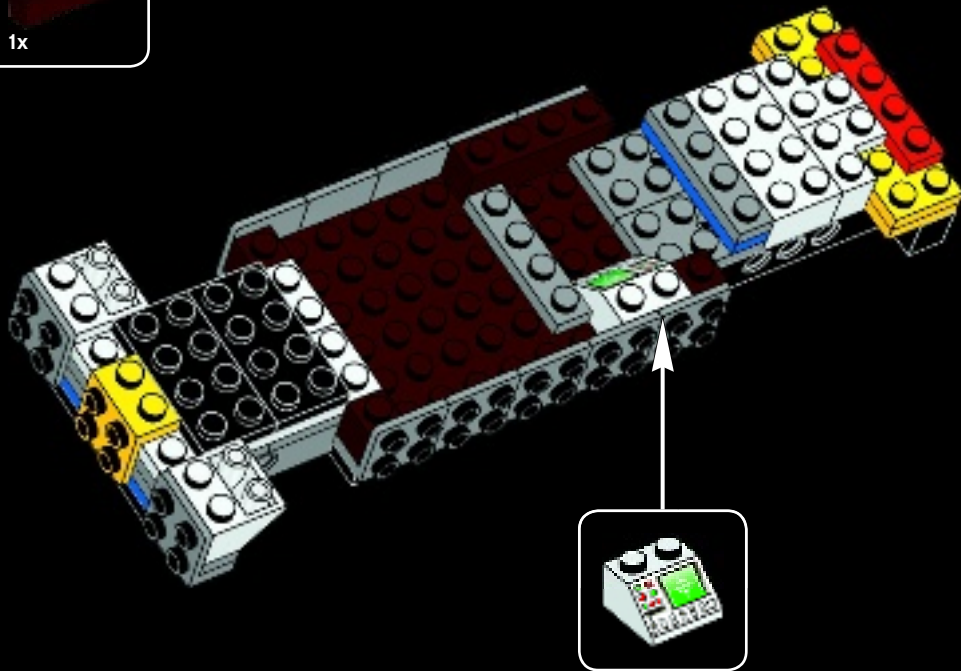

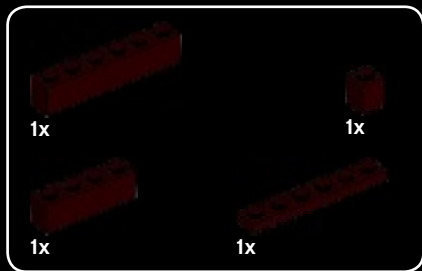

15

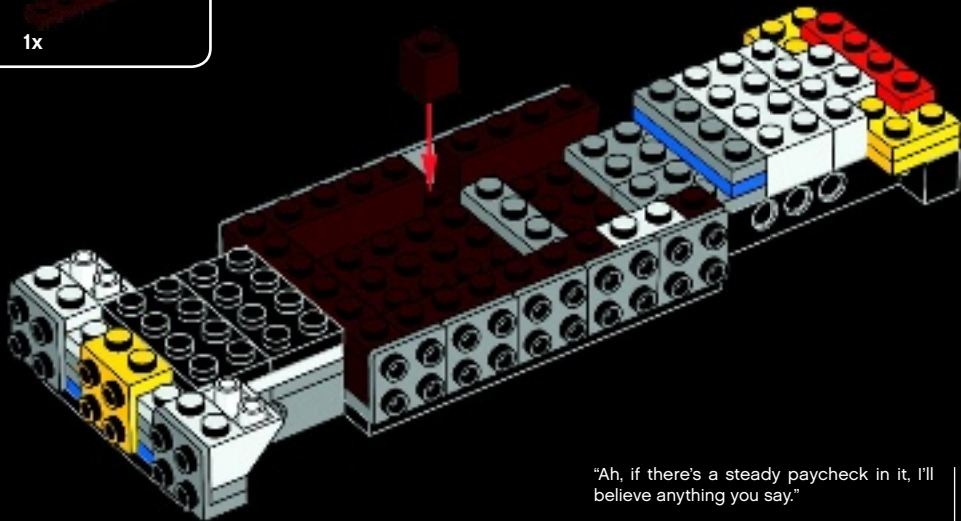

"Ah, if there's a steady paycheck in it, I'll believe anything you say."

ZEDDEMORE





2x

16

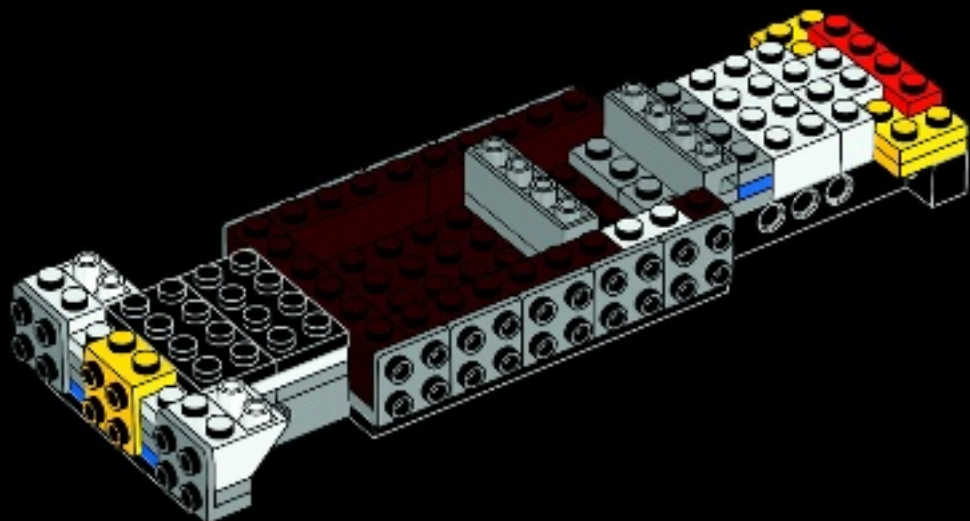

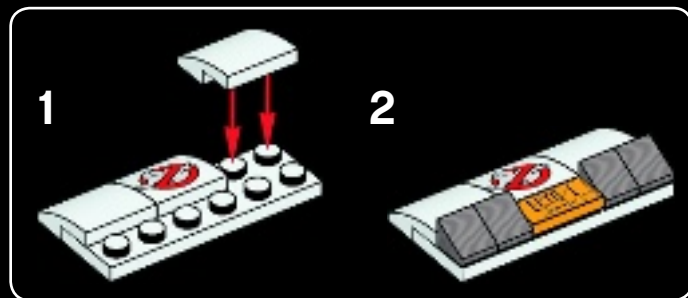
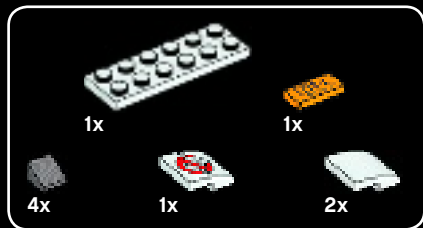

17

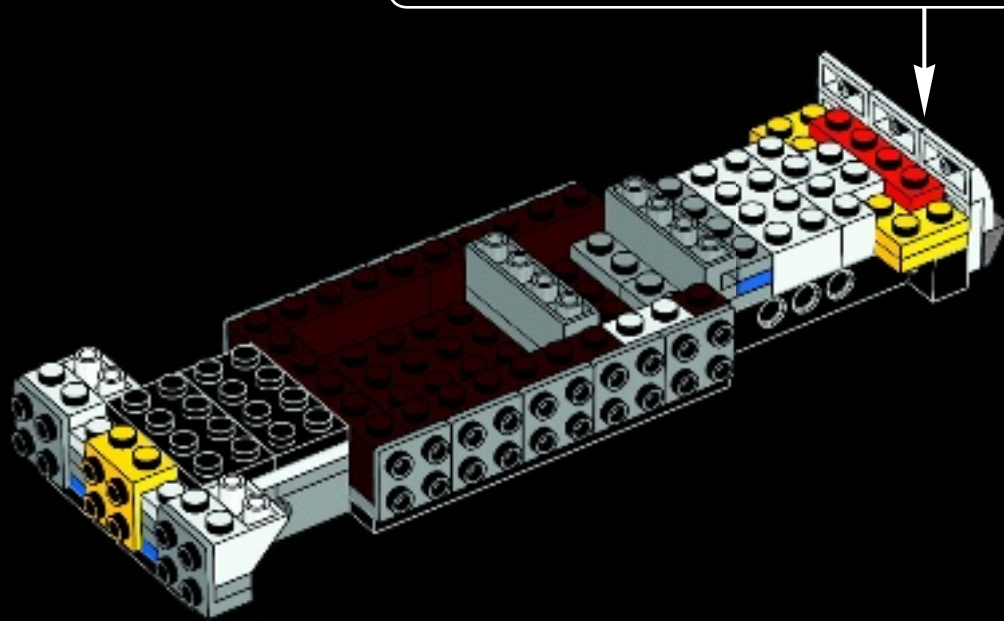



2x

18

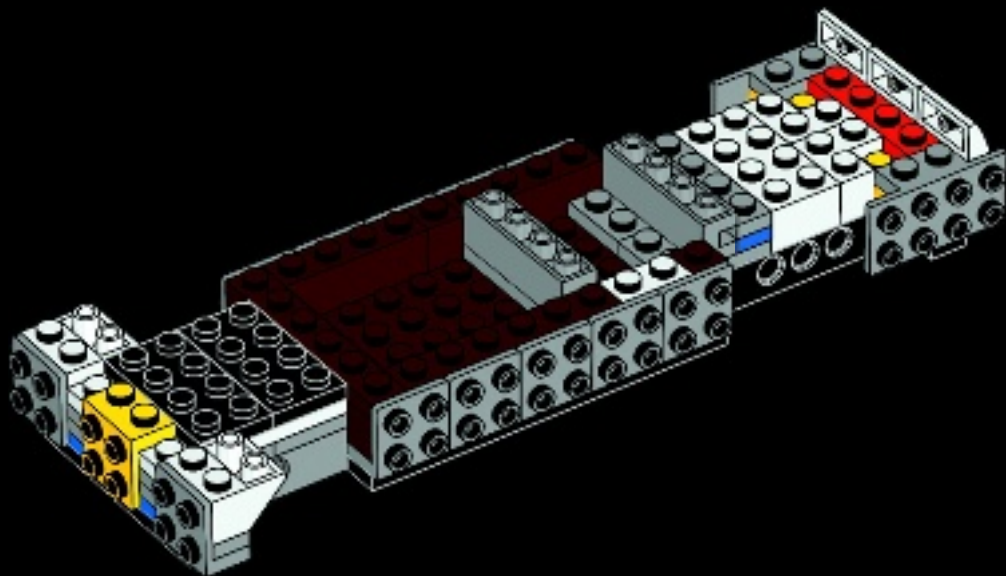





1x



2x

19

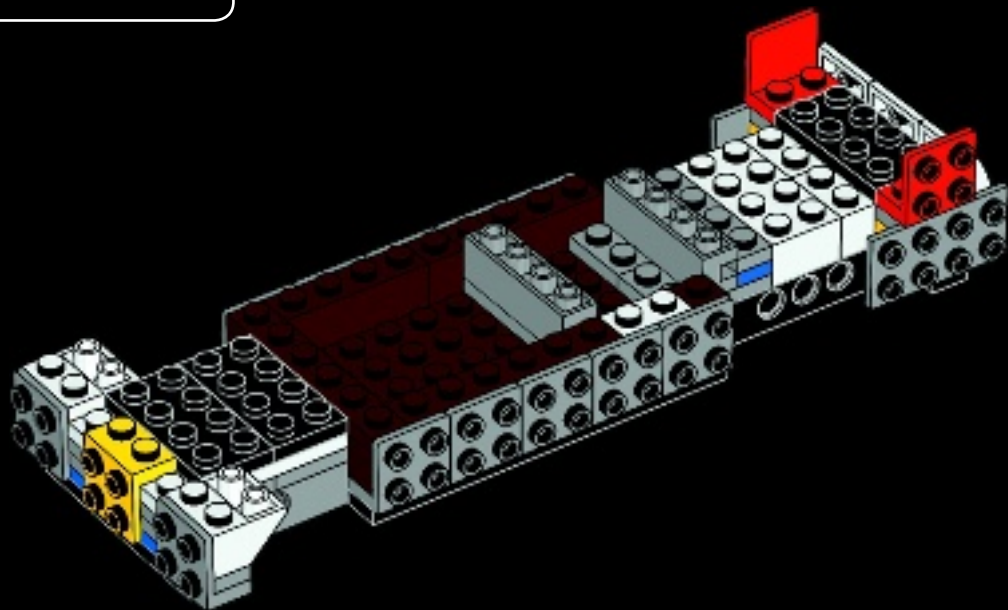



4x

20

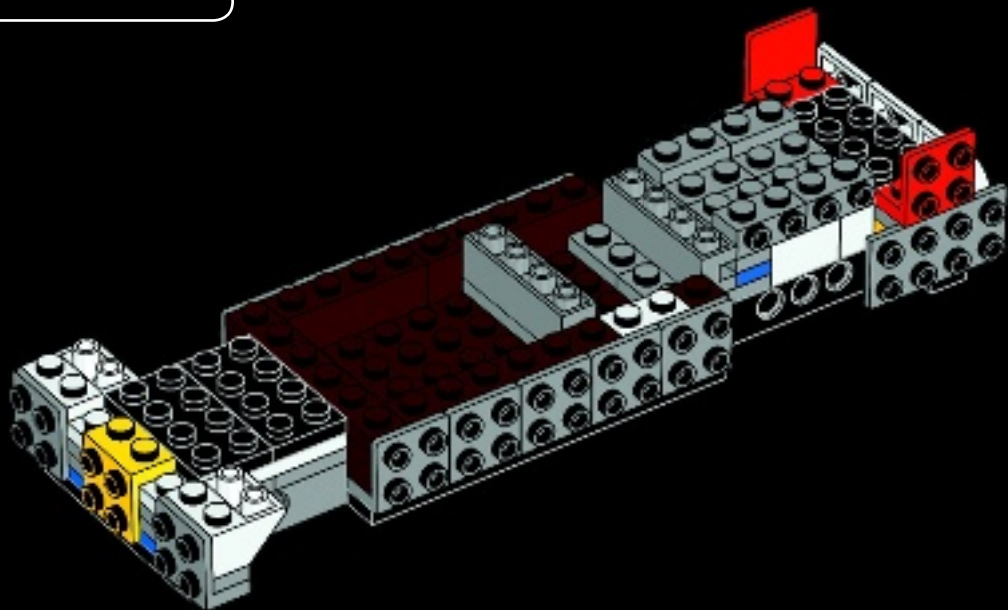



21

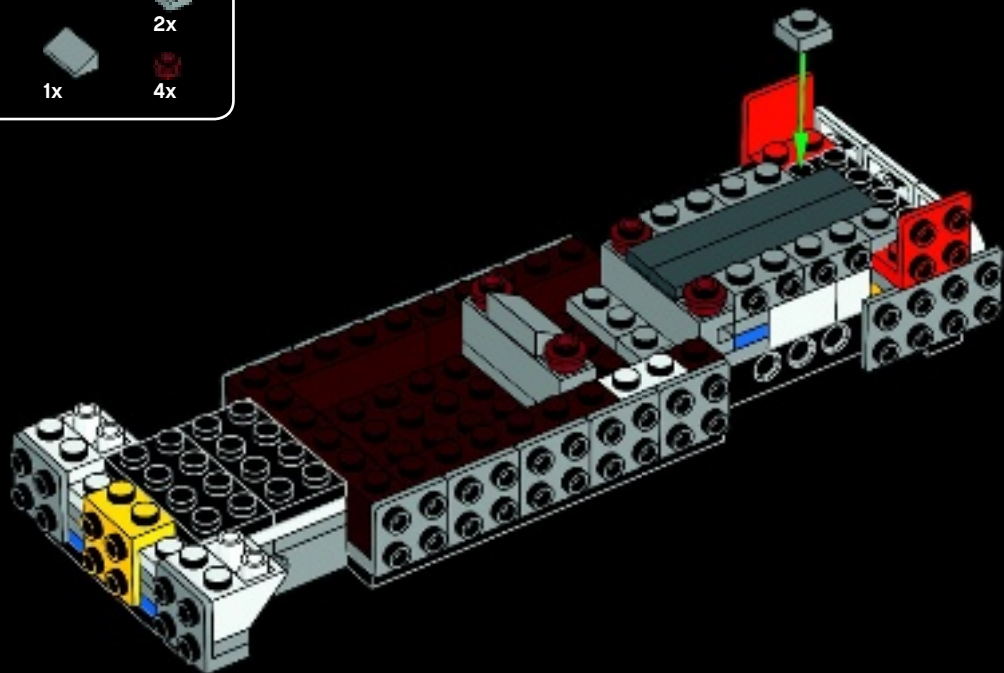

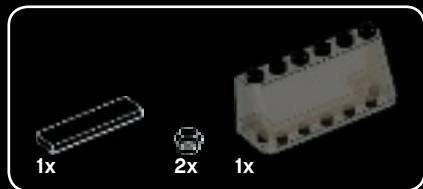

22

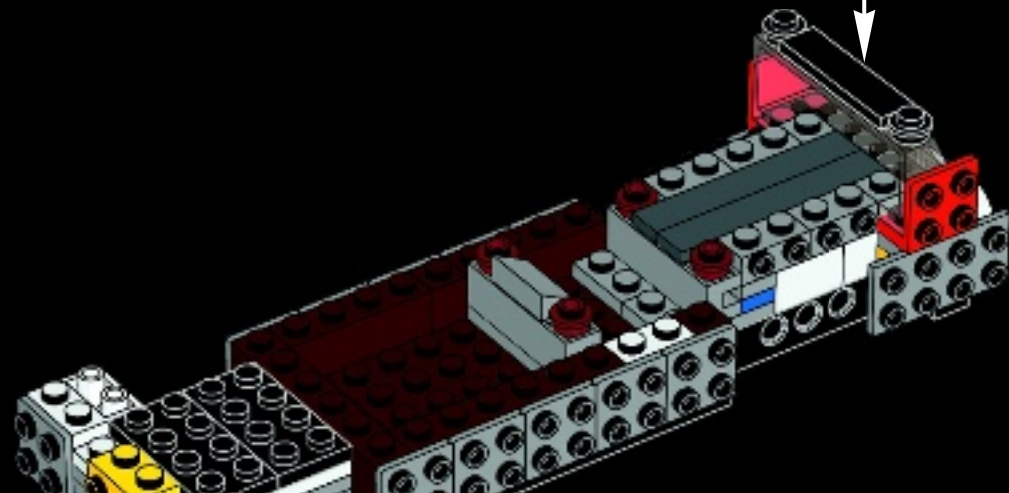
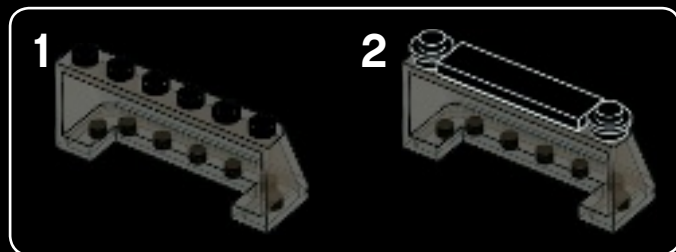



2x



2x

# 23

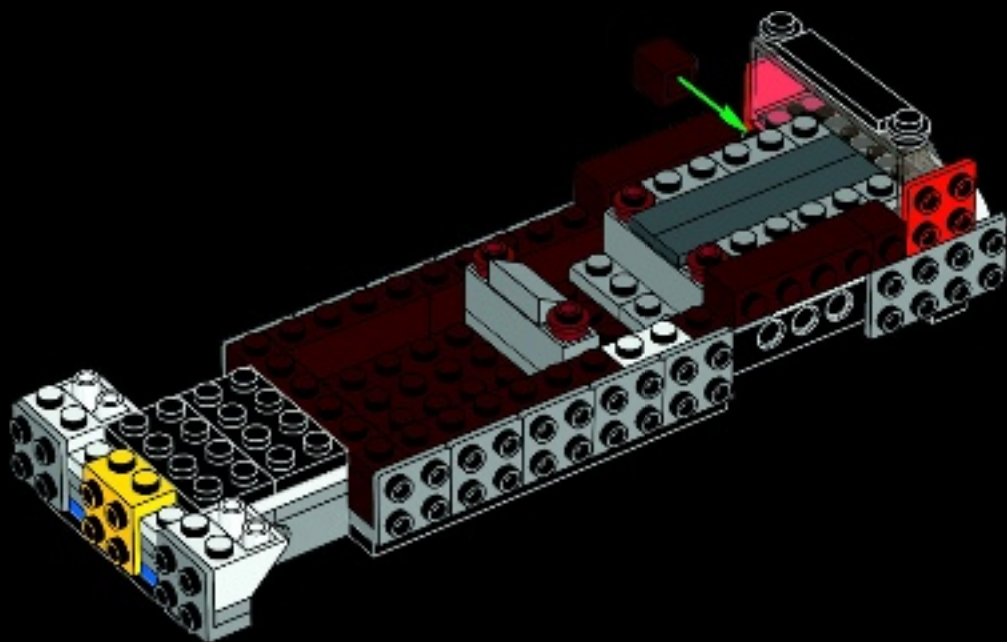



10x

24

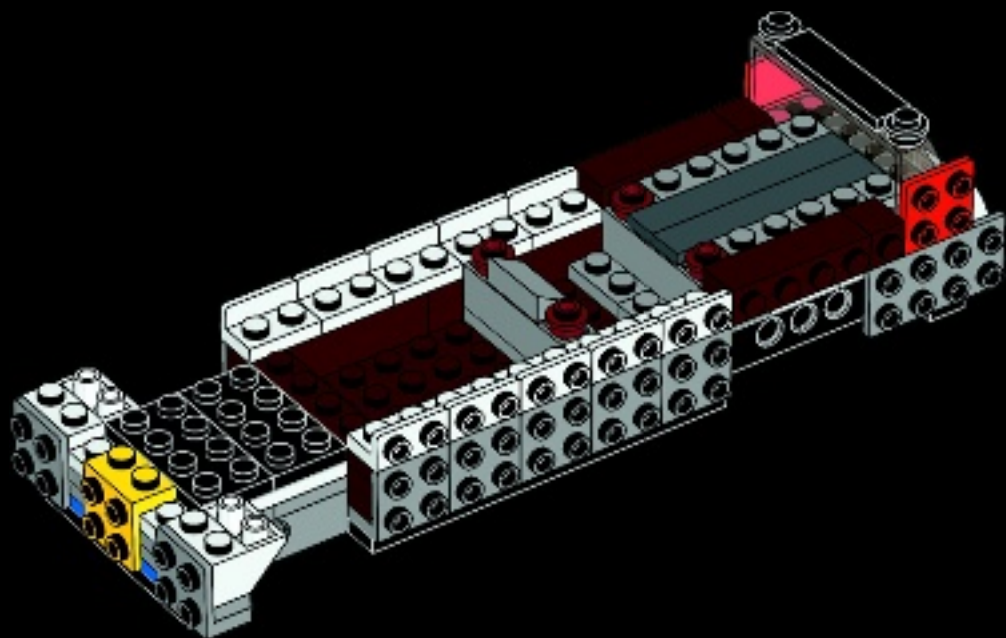



25

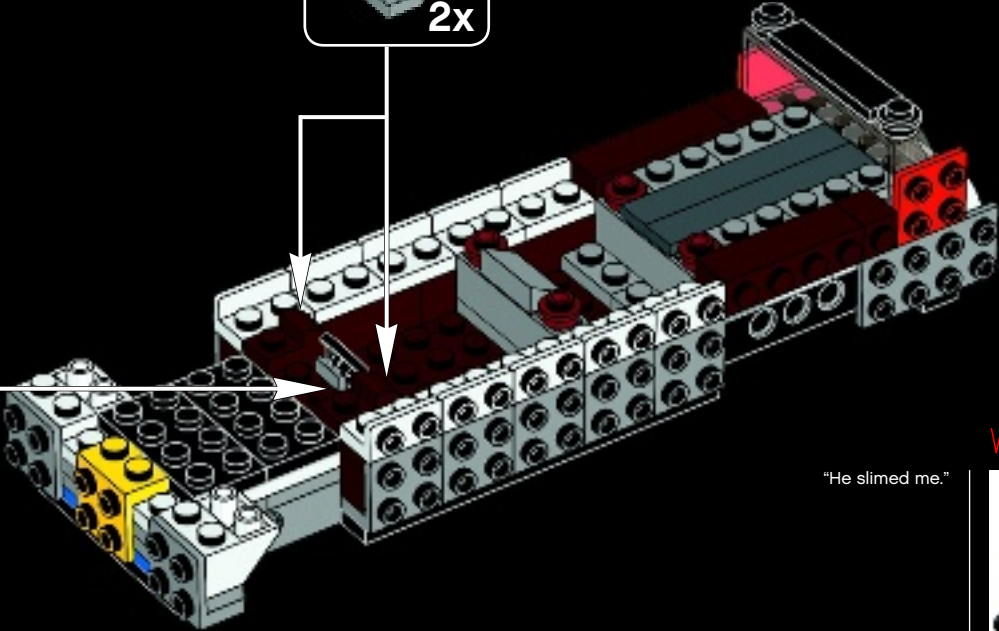

VENKMAN

"He slimed me."





1x



2x

# 26

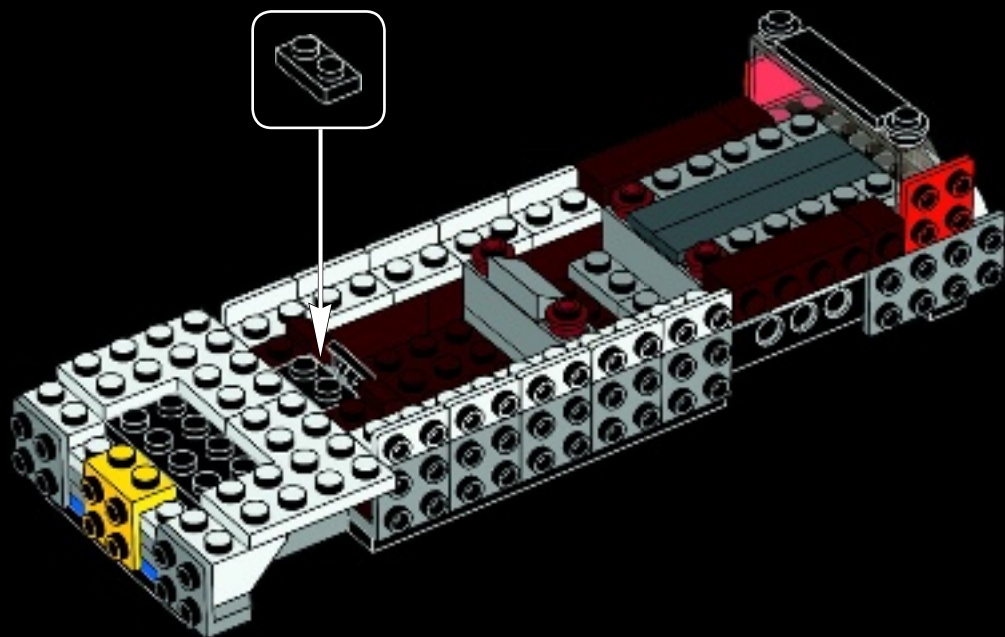





2x

1

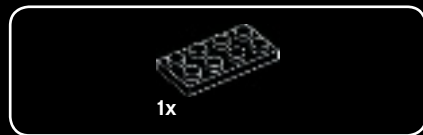
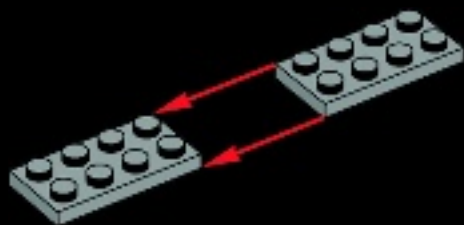

1x

2

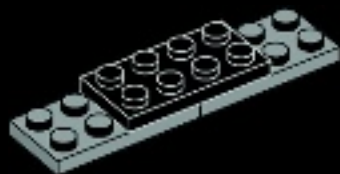



3

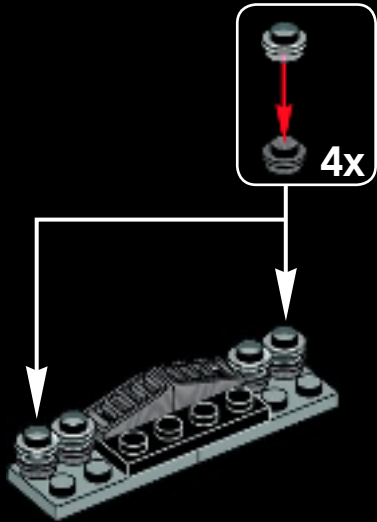

4



27

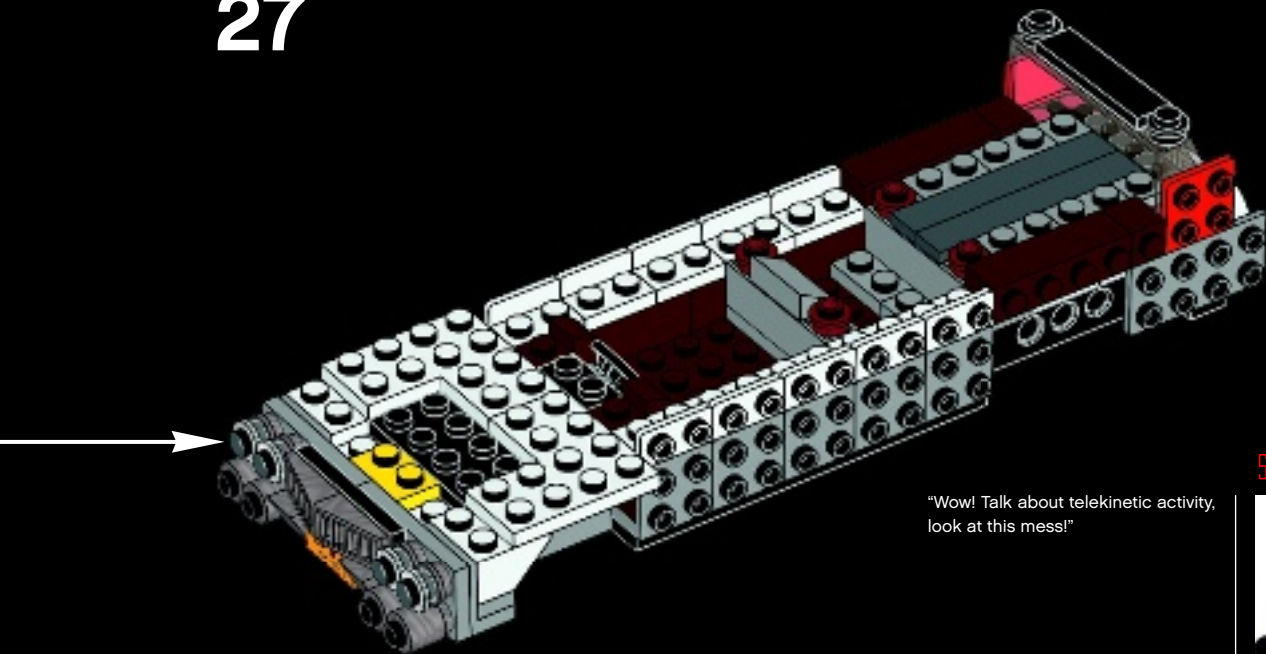

"Wow! Talk about telekinetic activity,  
look at this mess!"

STANTZ

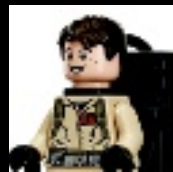



28

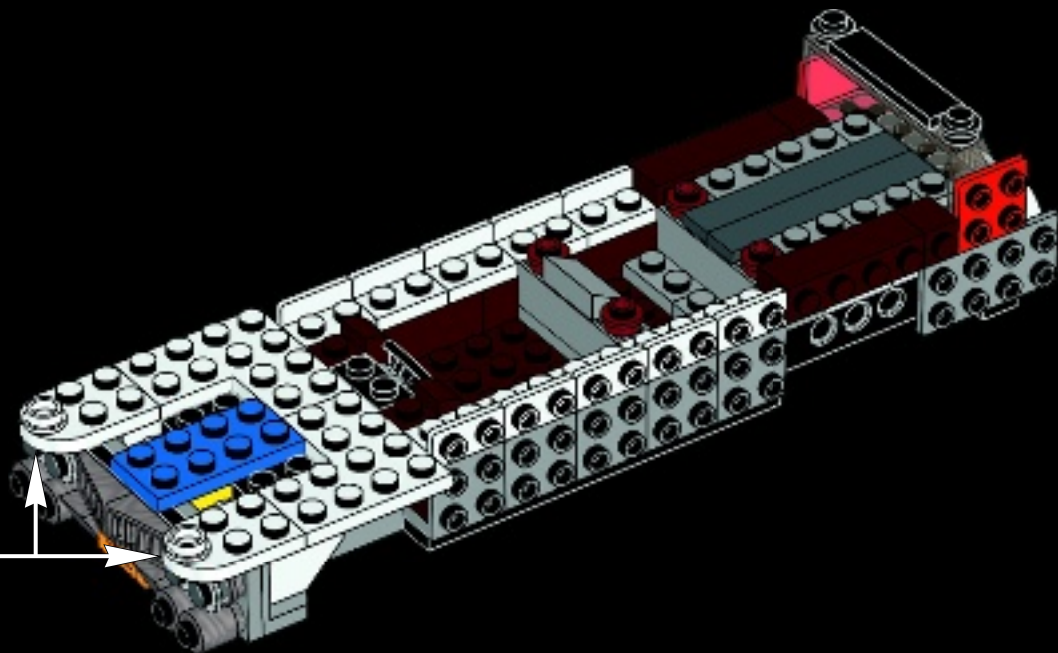



29

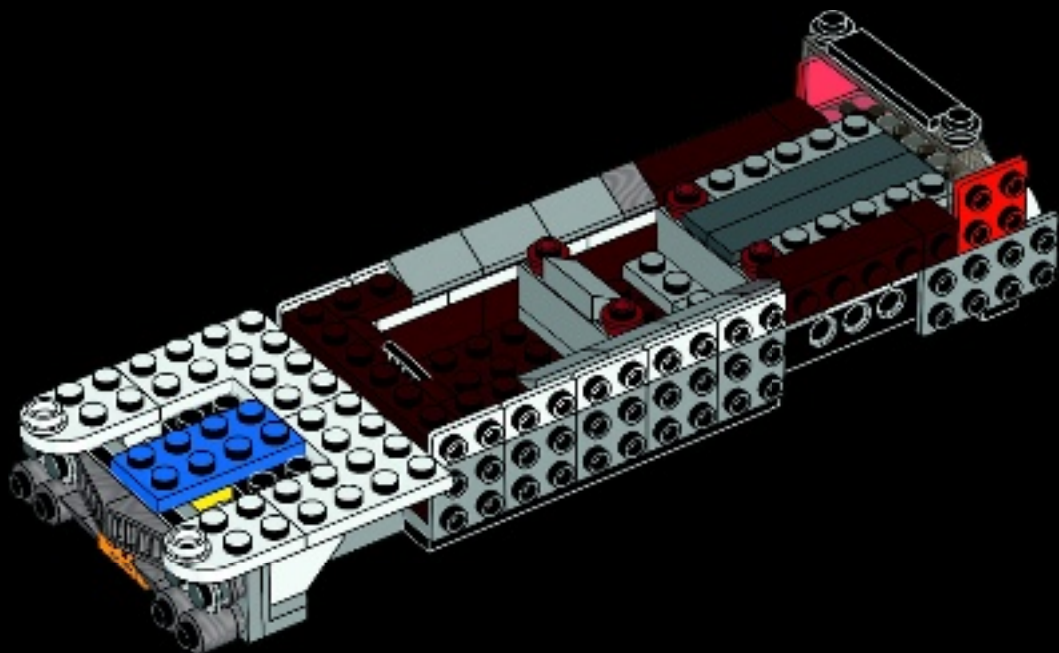



30

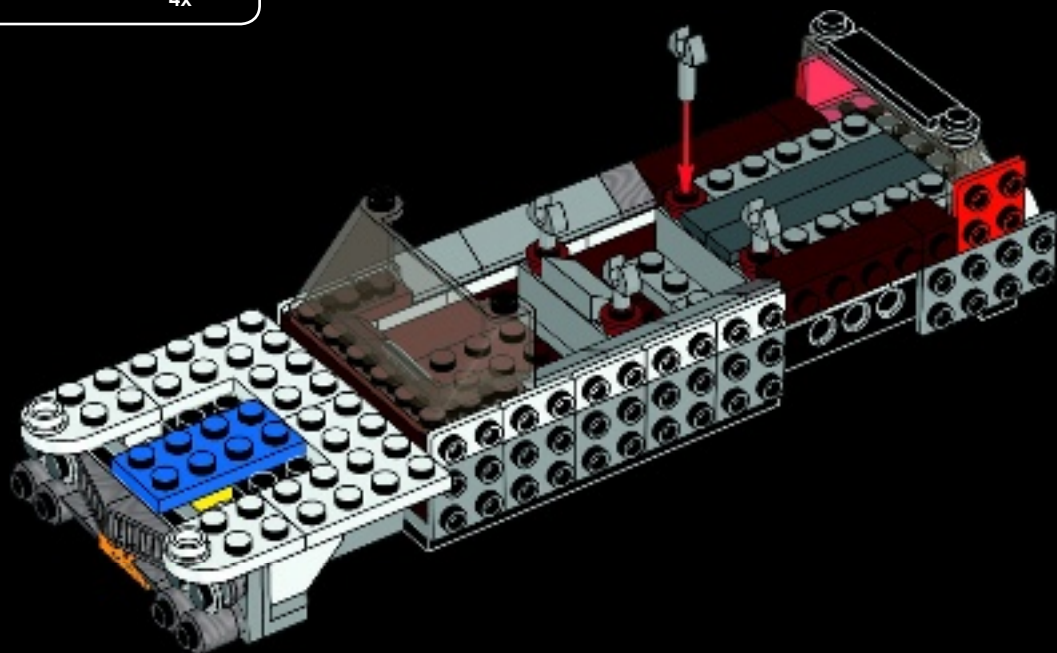



31

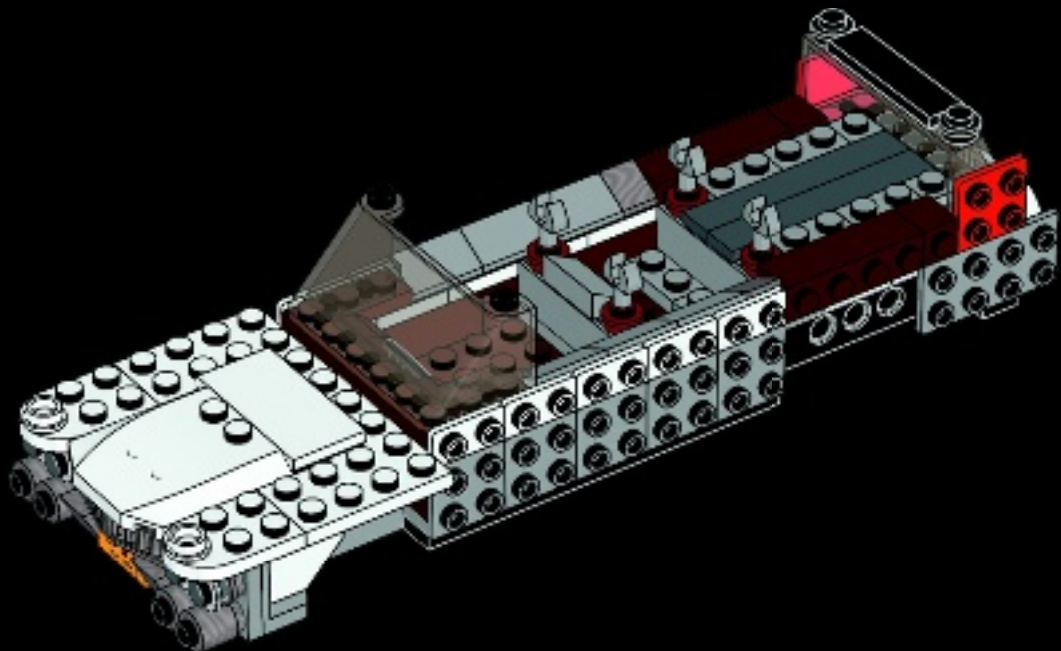



1x

2x

2x

2x

# 32

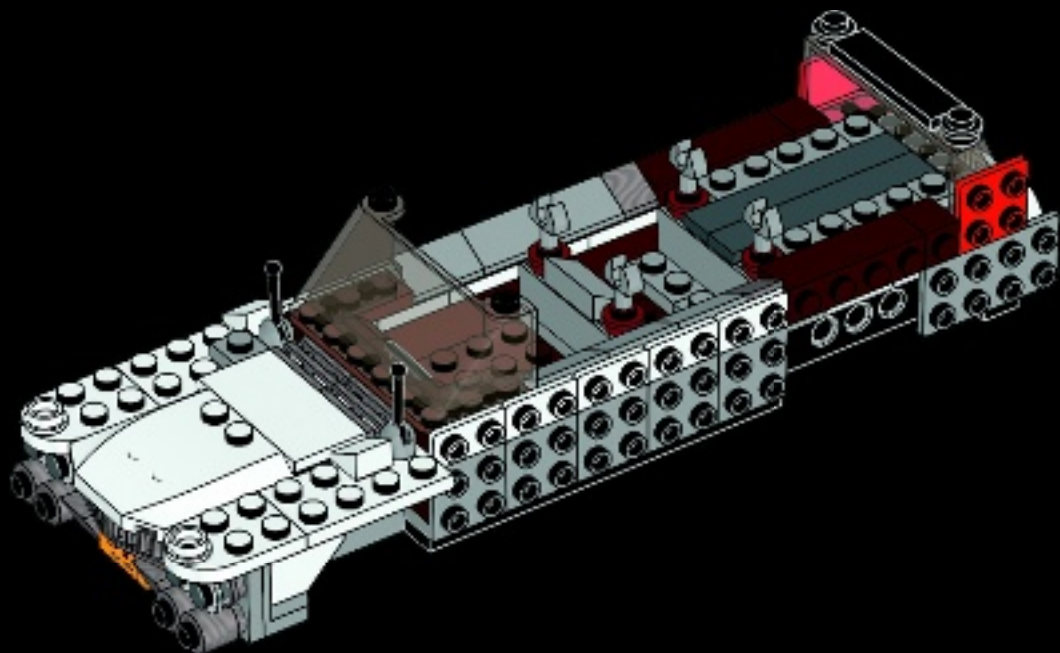





1x



2x

# 33

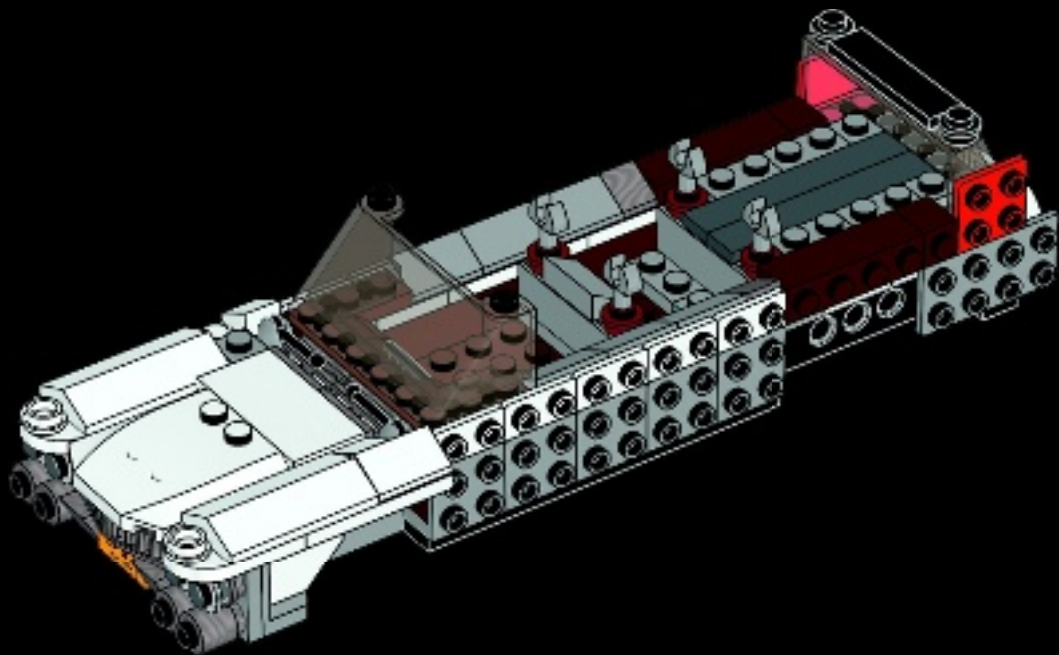



34

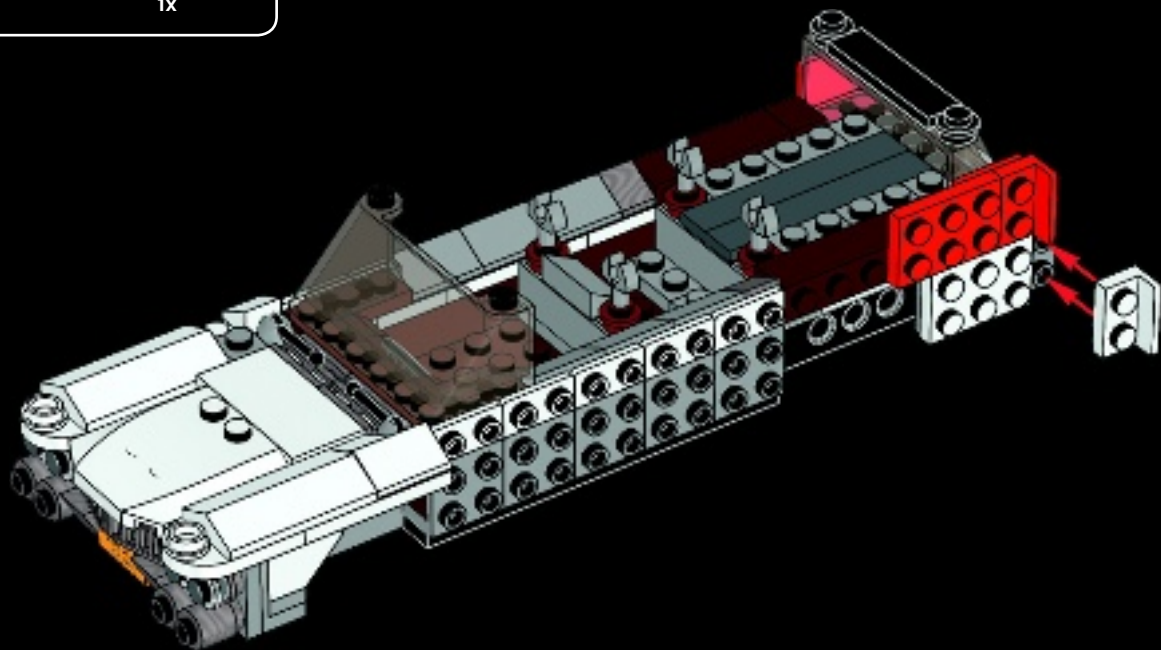

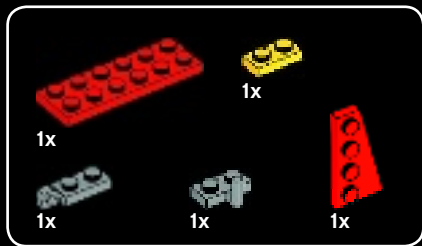

35

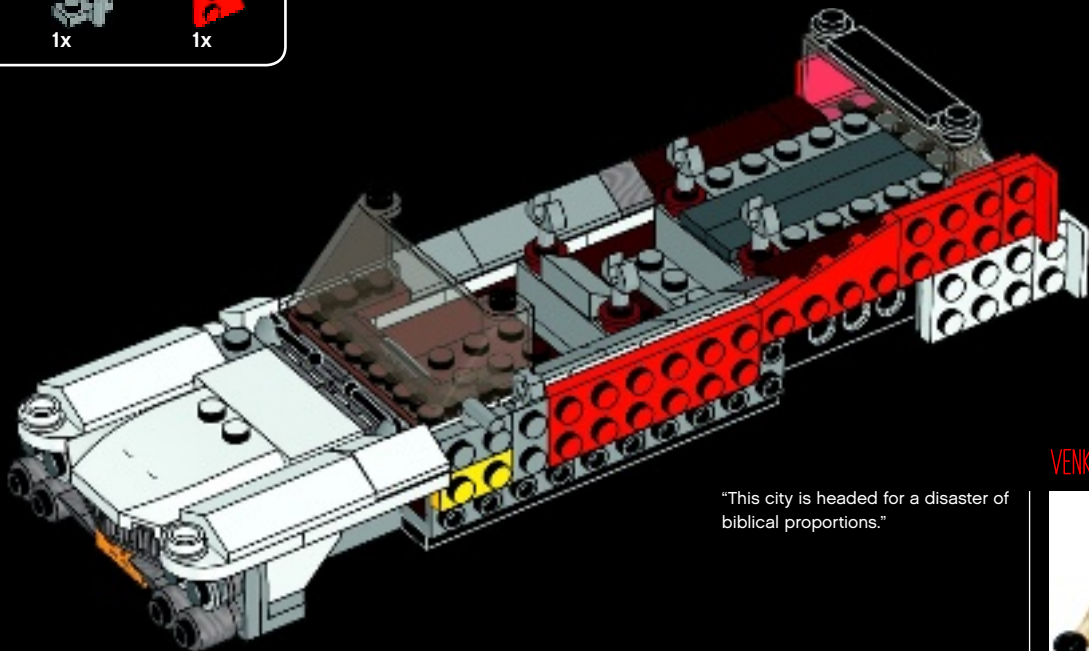

"This city is headed for a disaster of biblical proportions."

VENKMAN



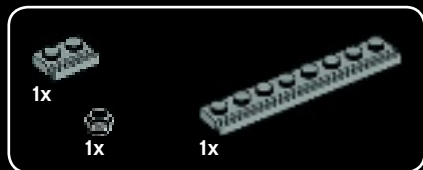

36

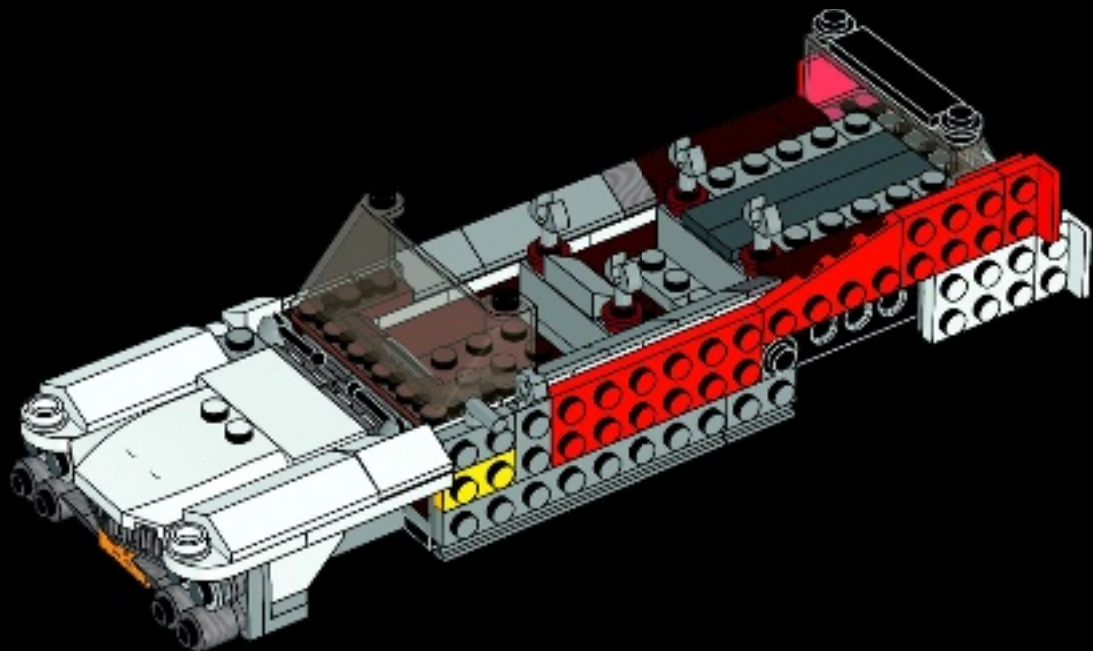



37

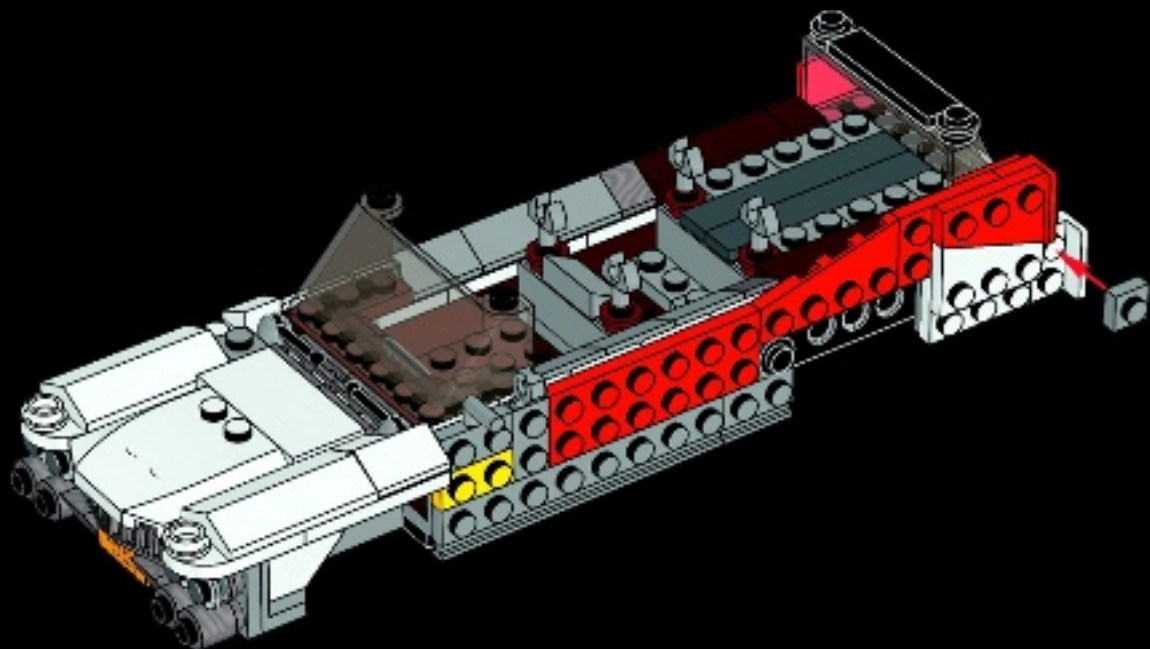



1x



1x

38

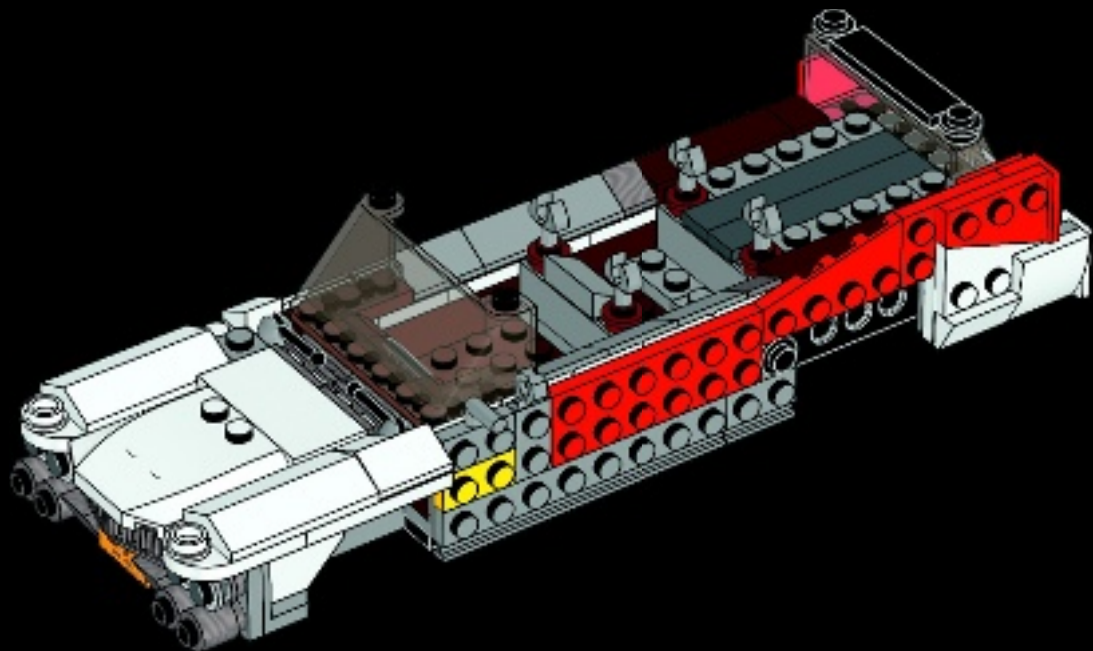



1x



2x

39

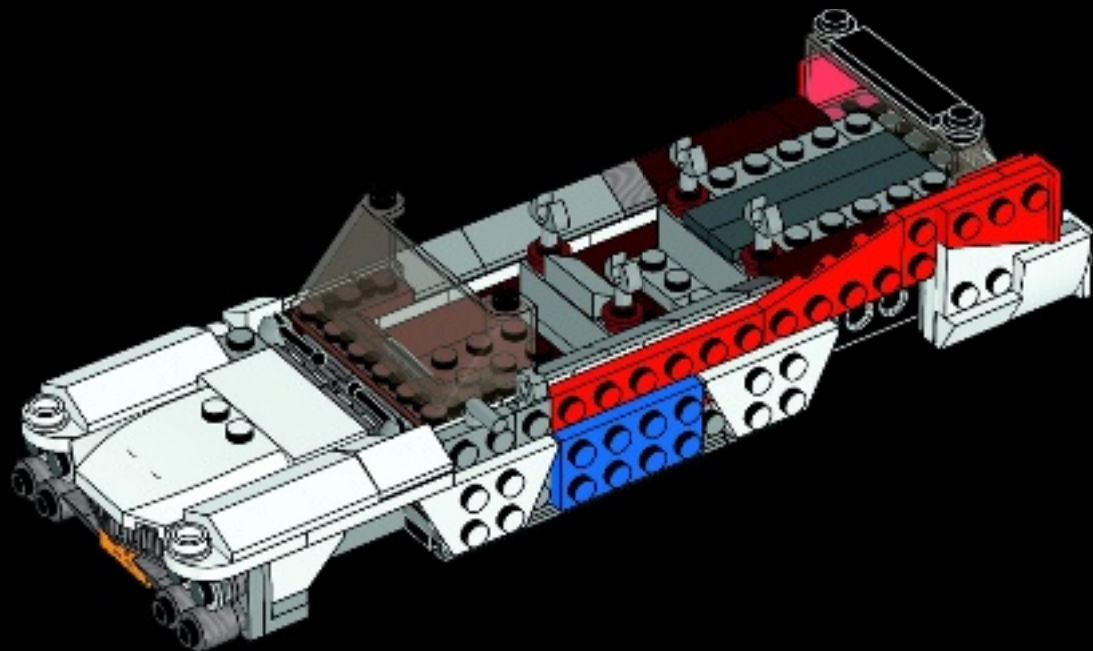





2x



2x

# 40

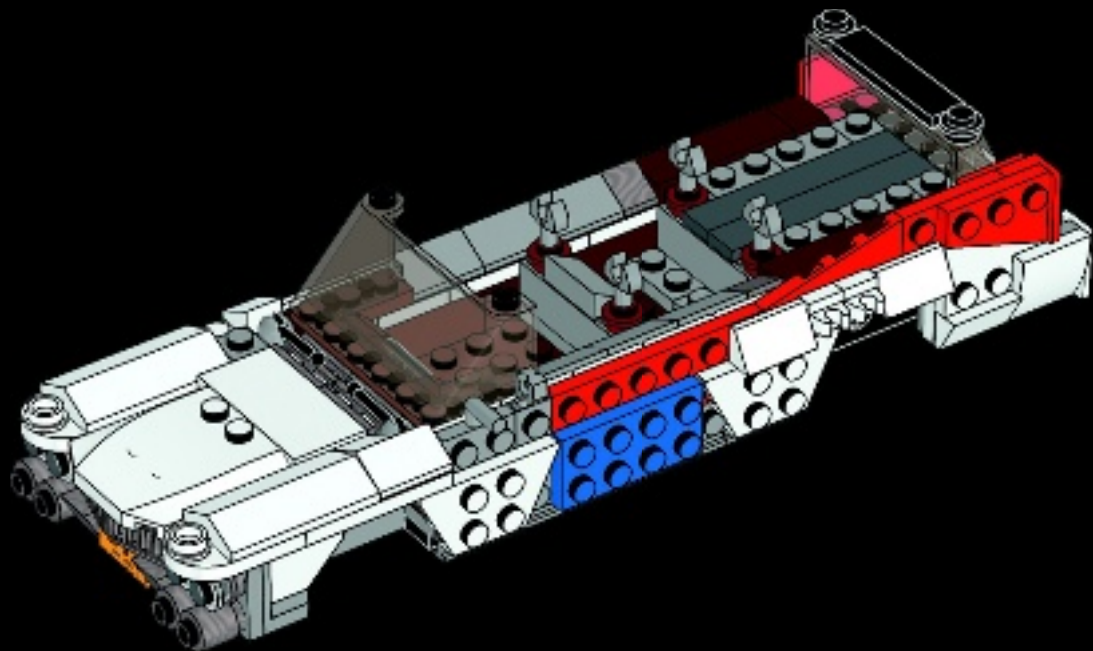

60



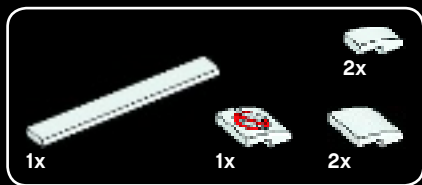

41

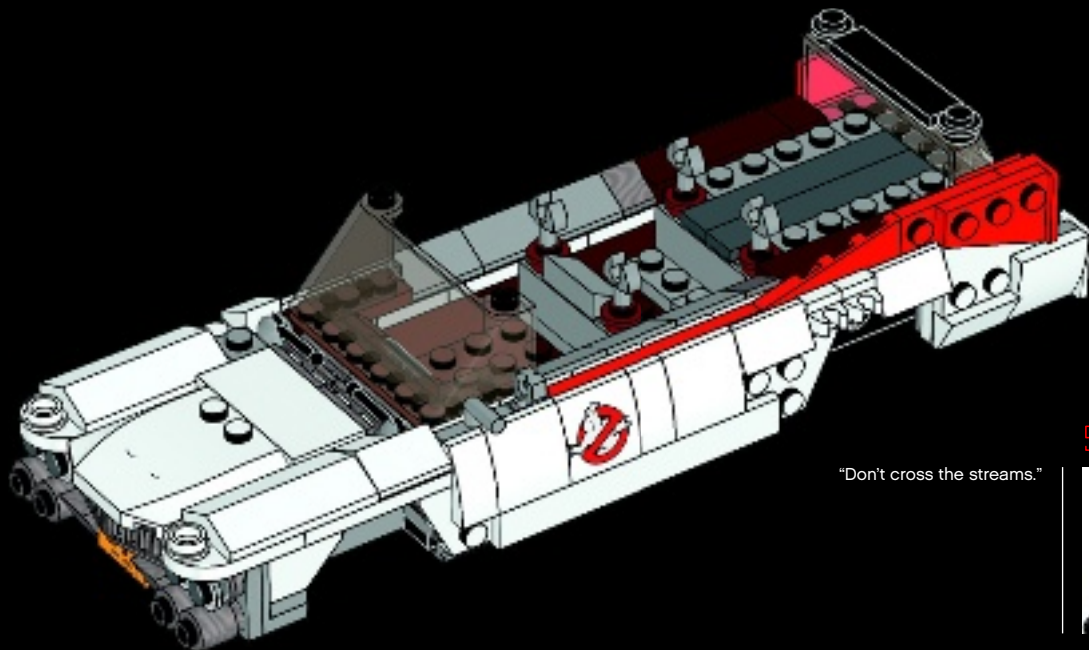

"Don't cross the streams."

SPENGLER





42

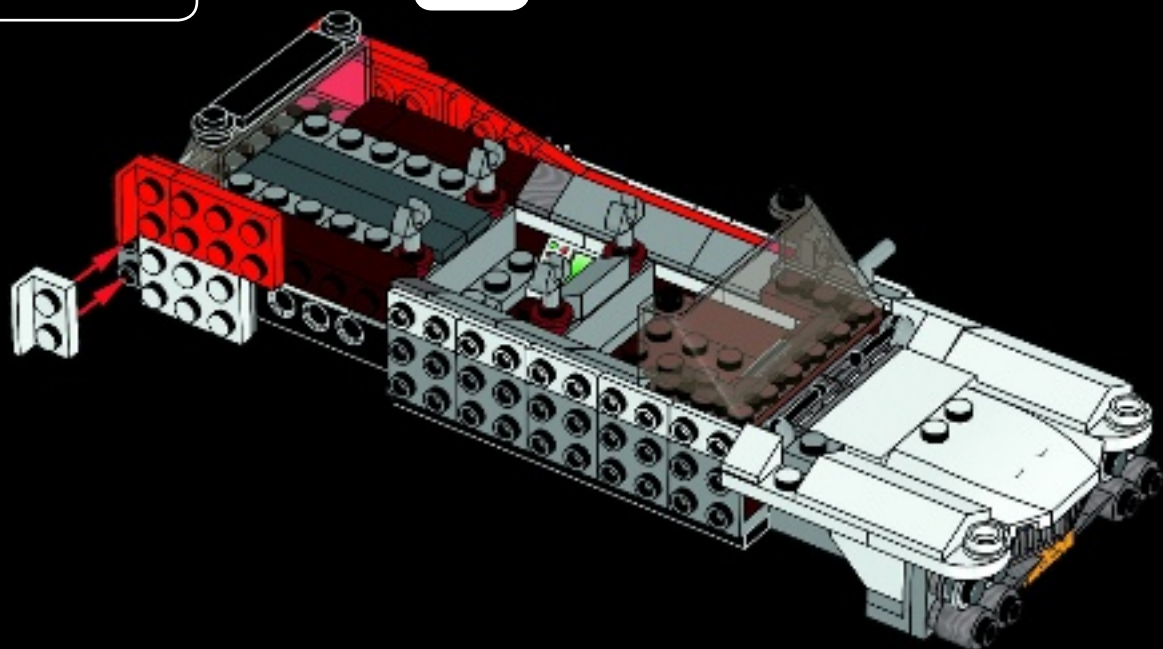

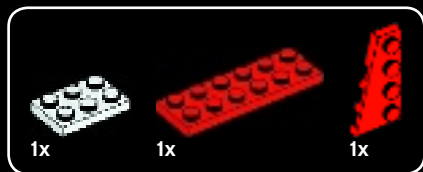

43

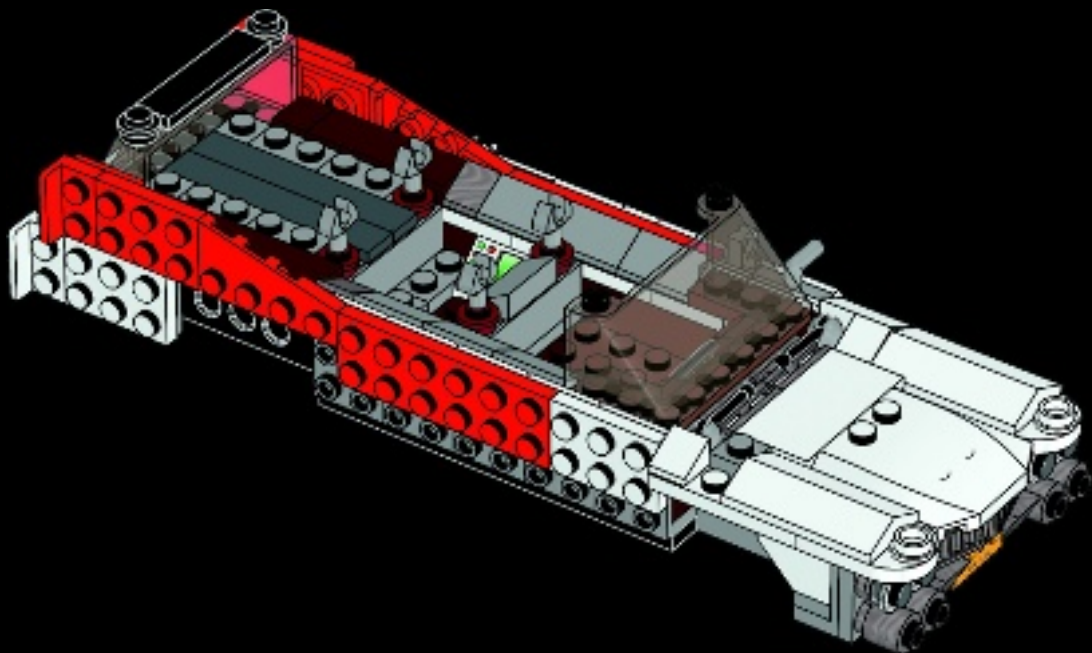



44

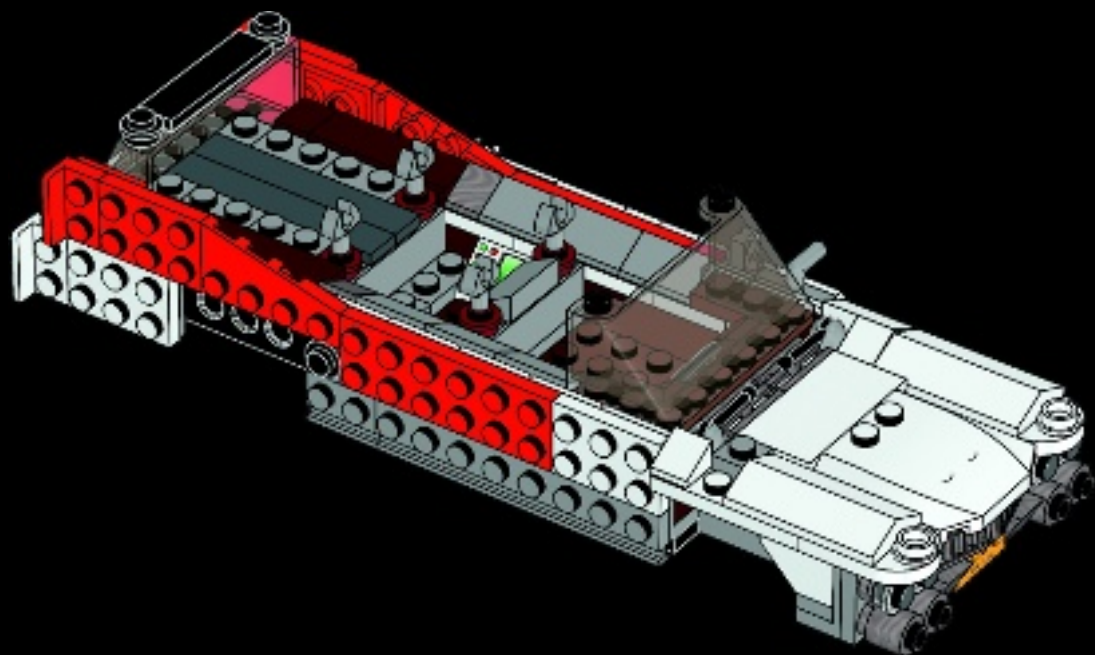



45

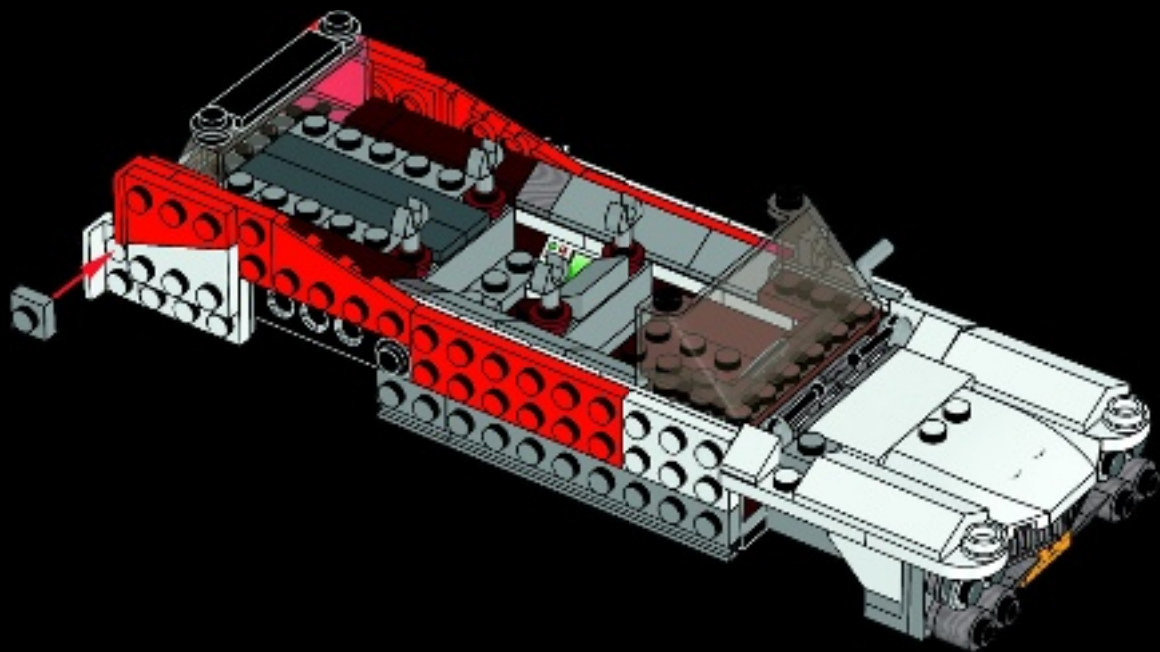



1x



1x

# 46

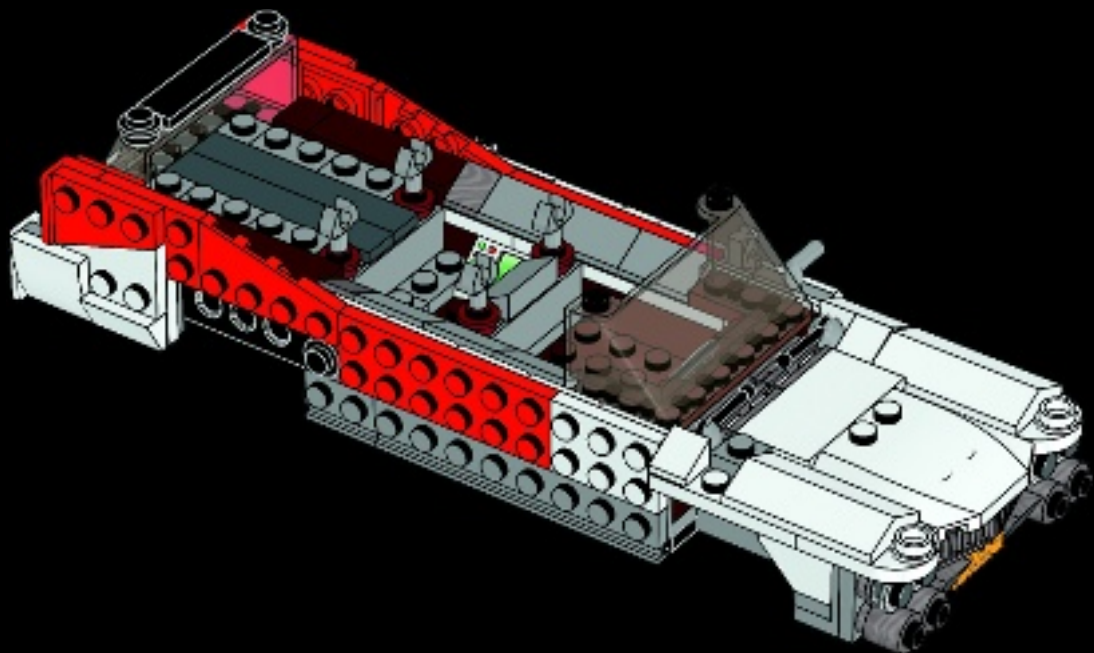



3x

47

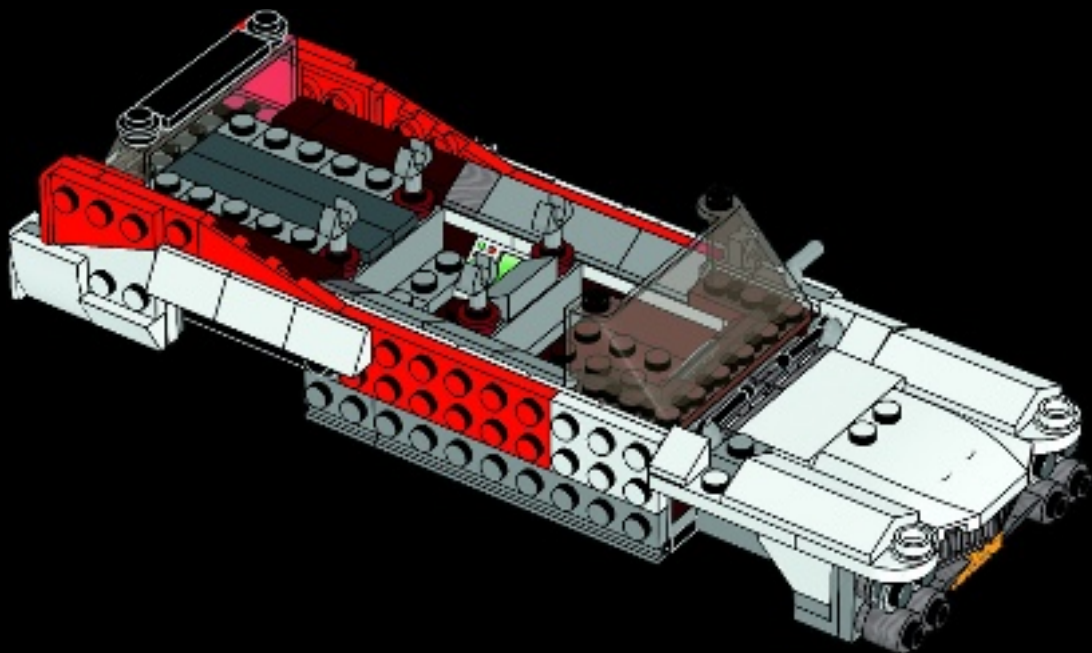





1x



2x

# 48

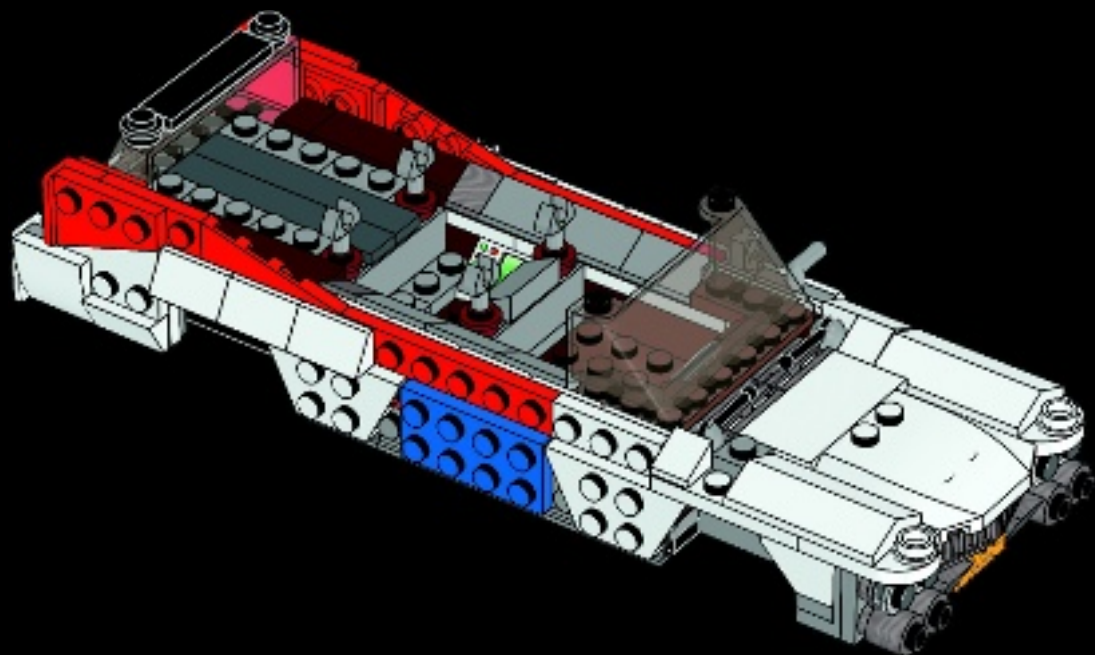



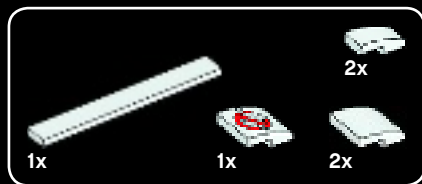

49

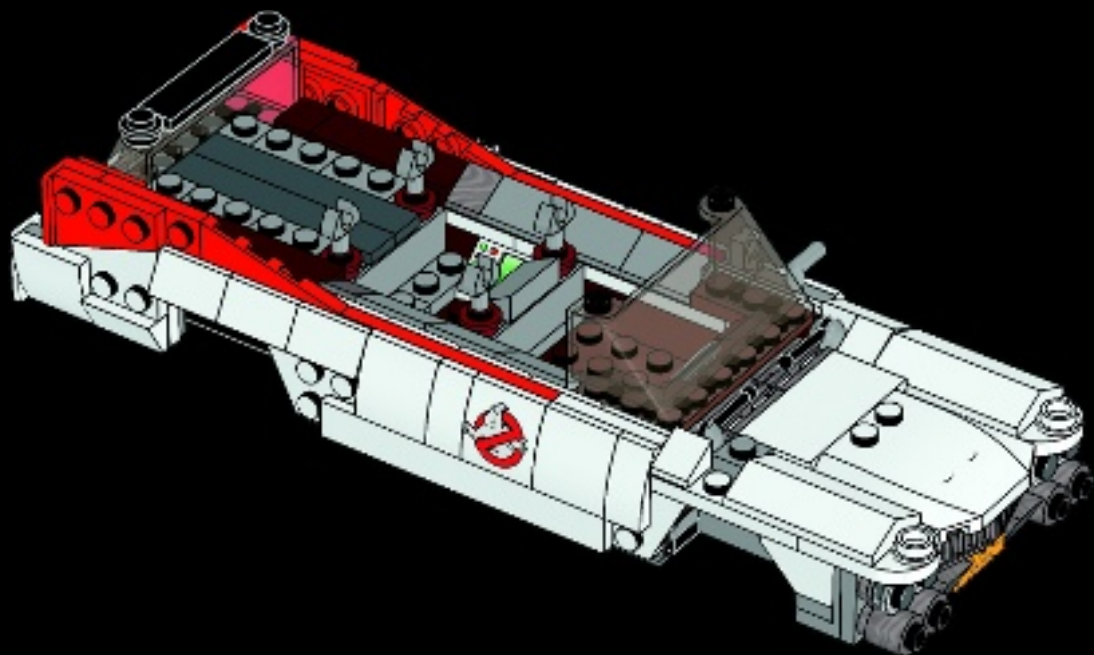



2x



2x

50

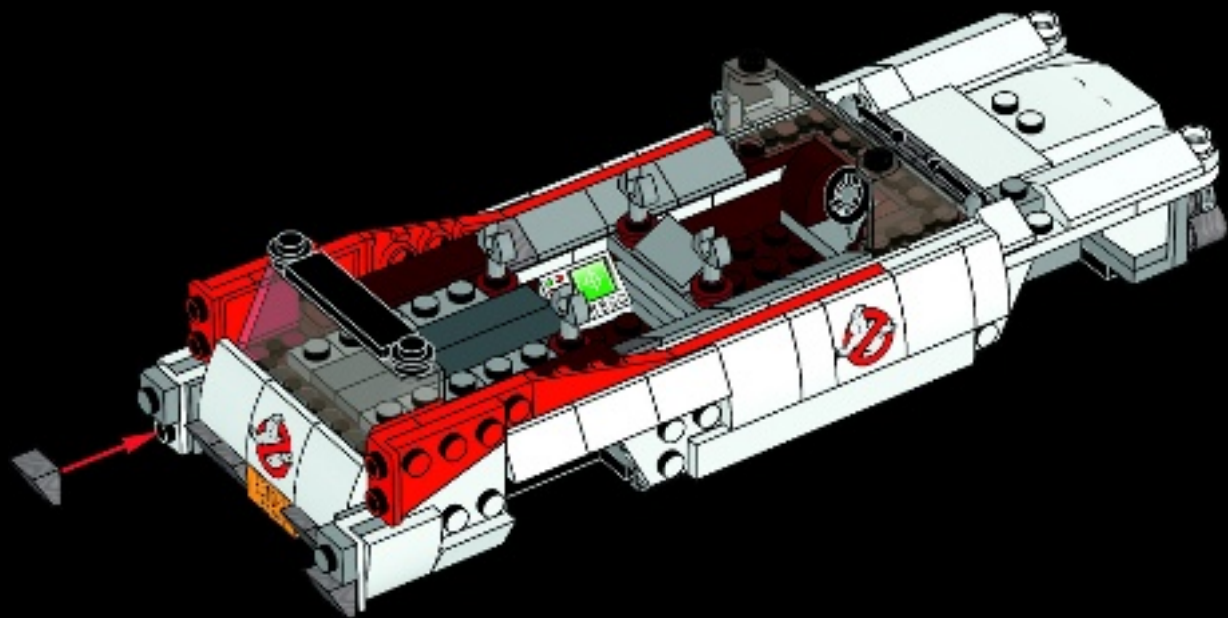

70



2x



2x



2x

# 51

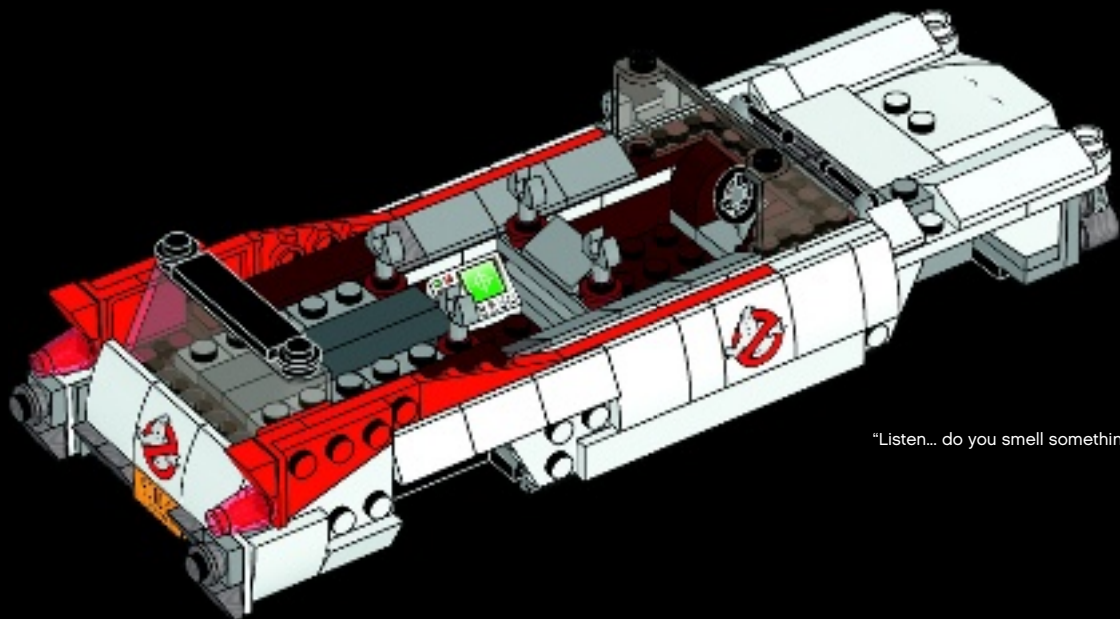

"Listen... do you smell something?"

STANTZ

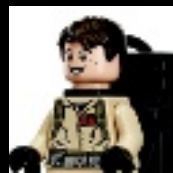



10x

52

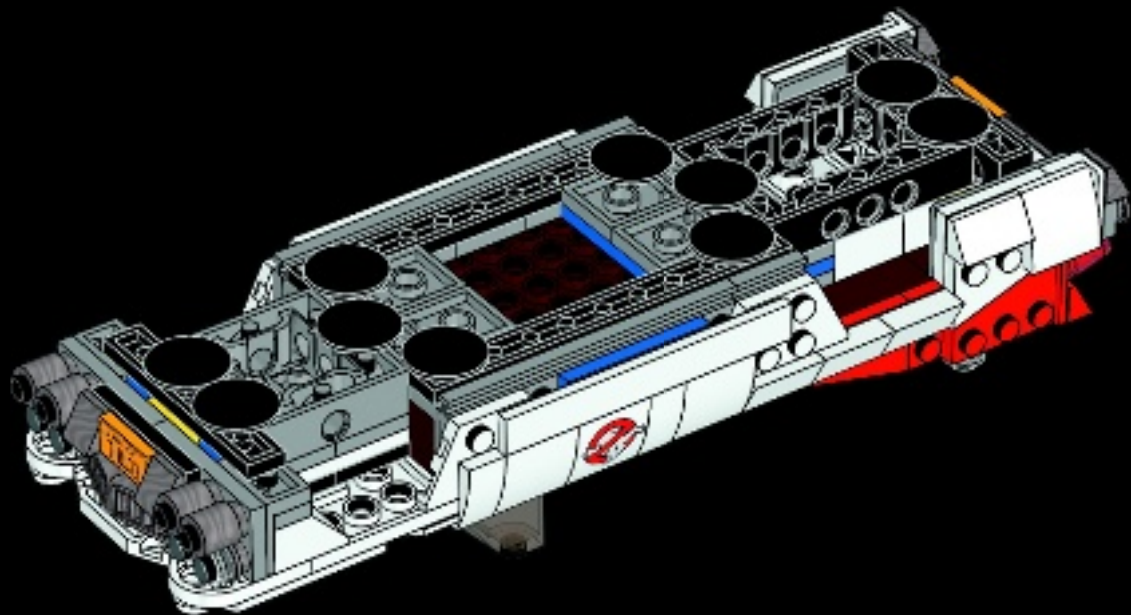



53

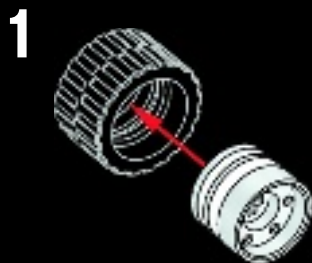

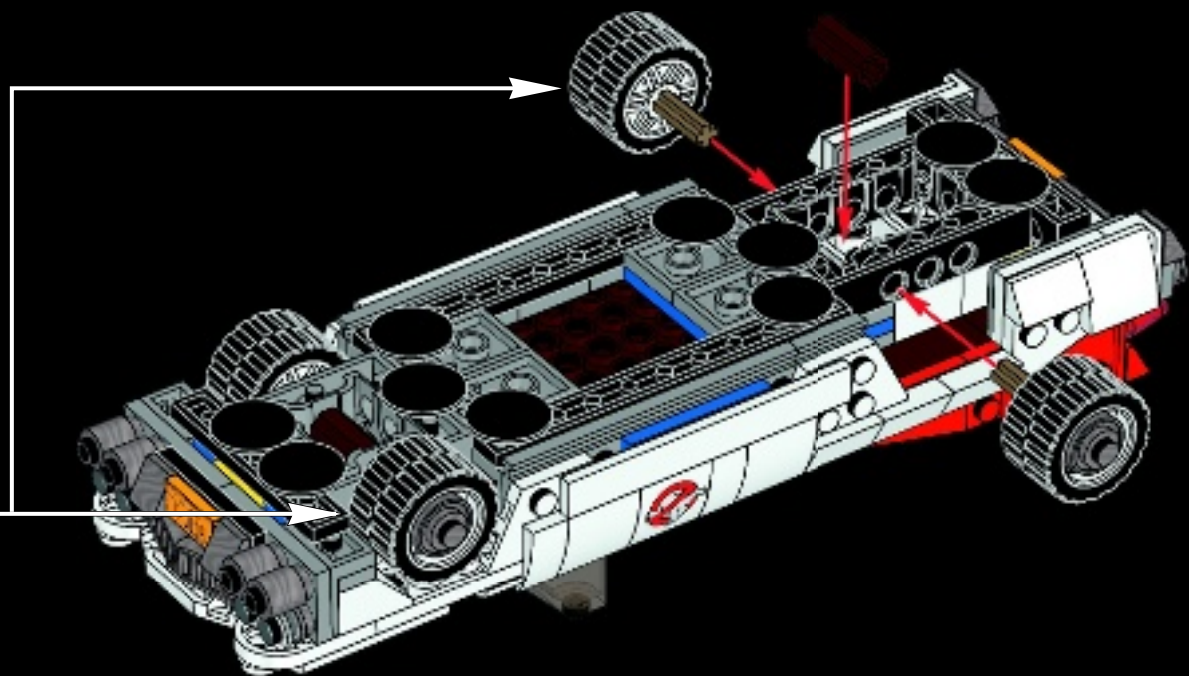



54

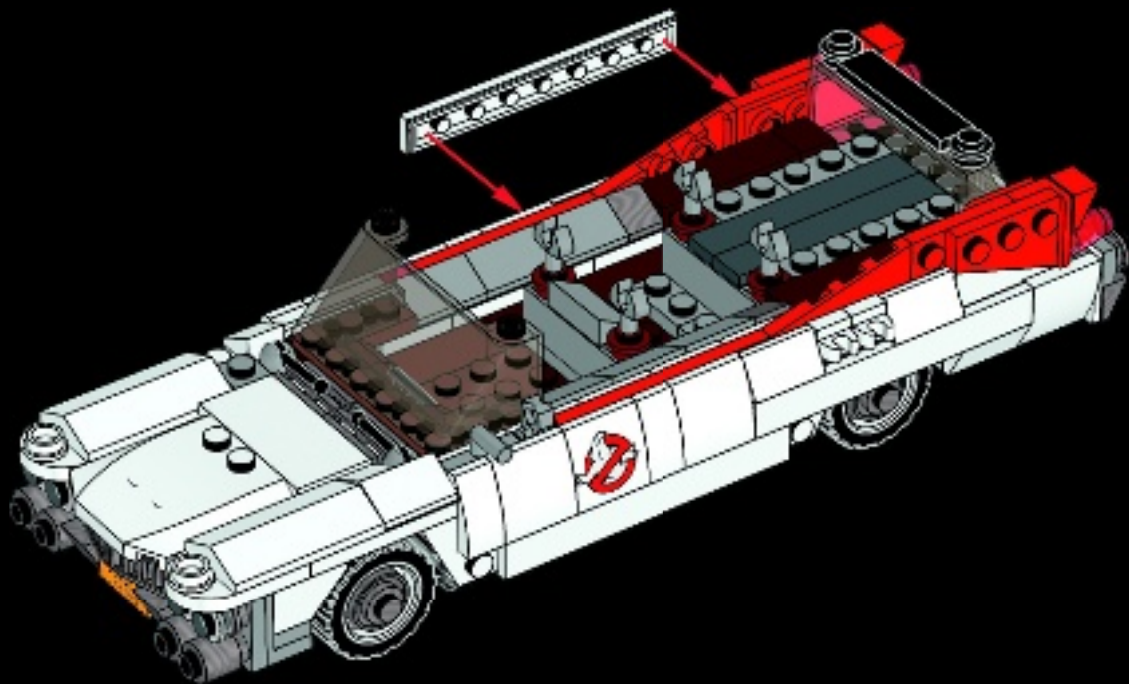

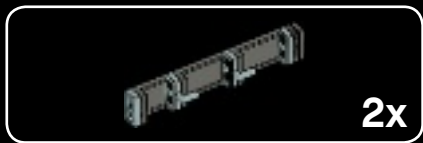

55

1

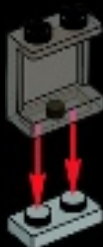

2





3



4



5



2x

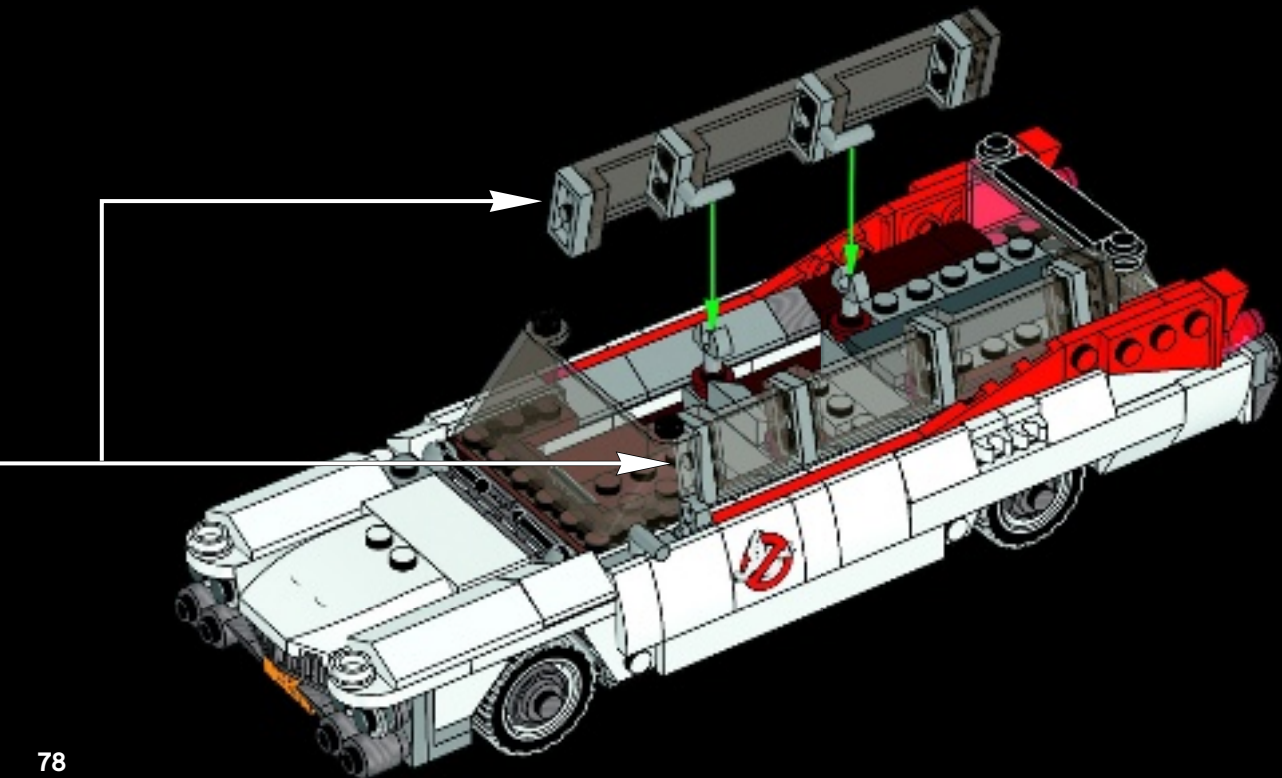



56

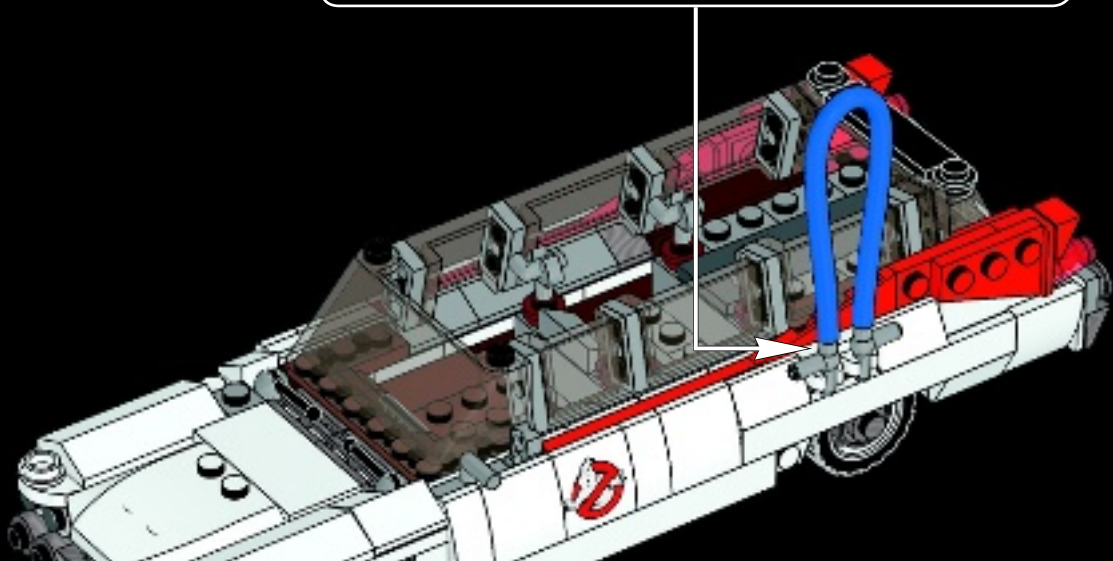
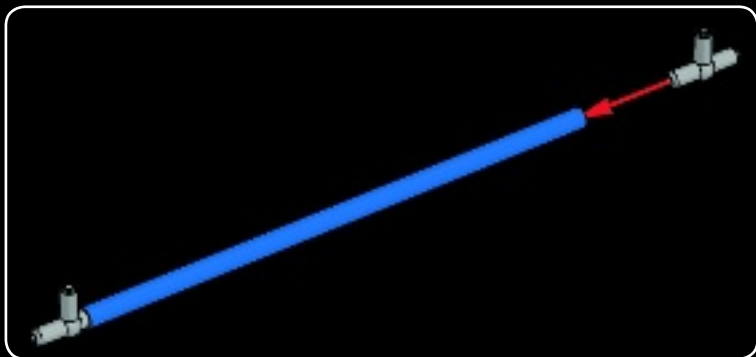

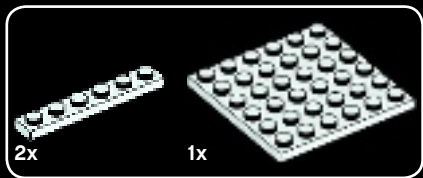

1

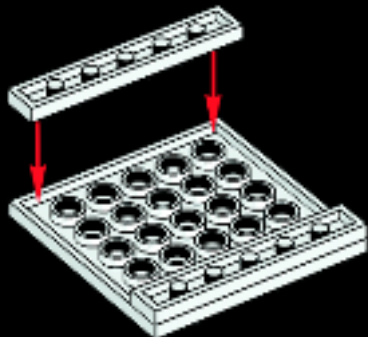

2





3



4

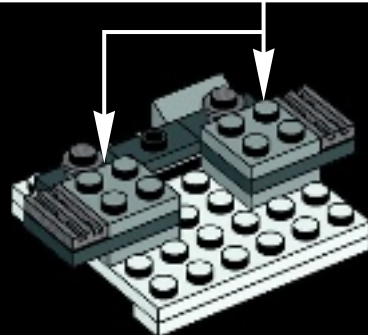
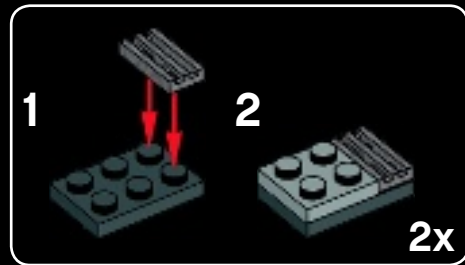



2x



1x



1x

1

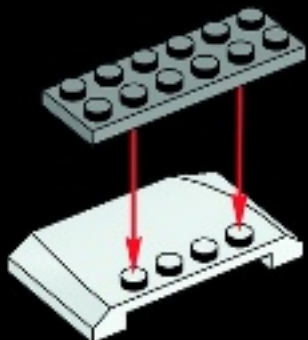

8x

2





3

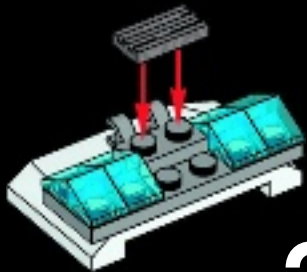

2x

5

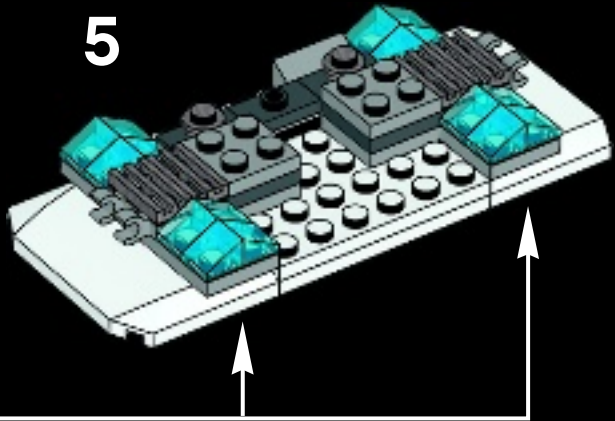

"I'm terrified beyond the capacity for rational thought."

SPENGLER





6

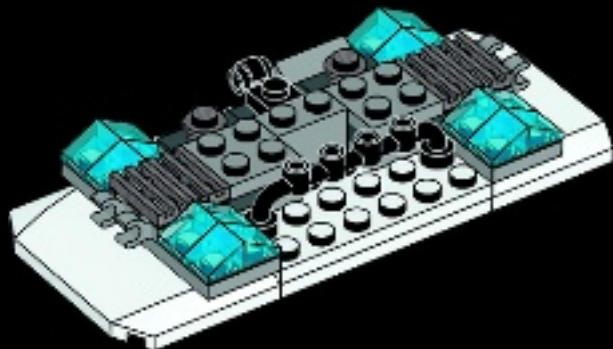

7

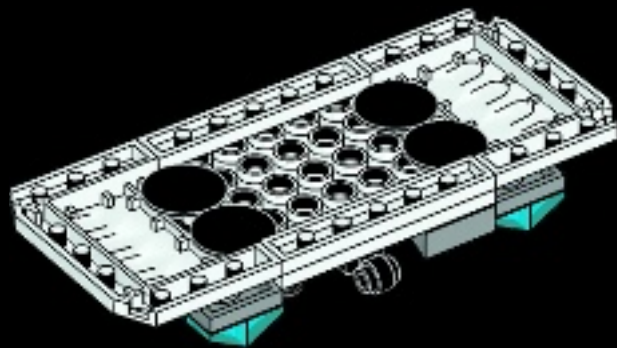





8

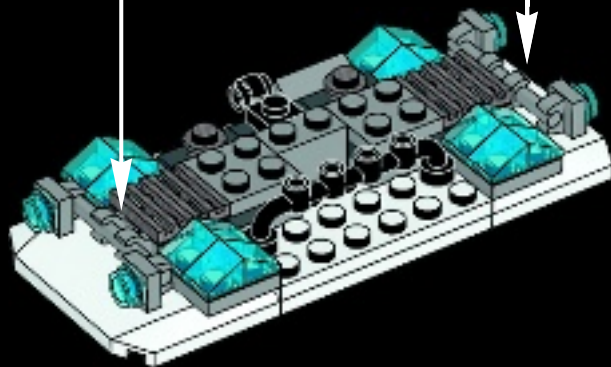



2x



2x



2x



2x

9

1



2



2x

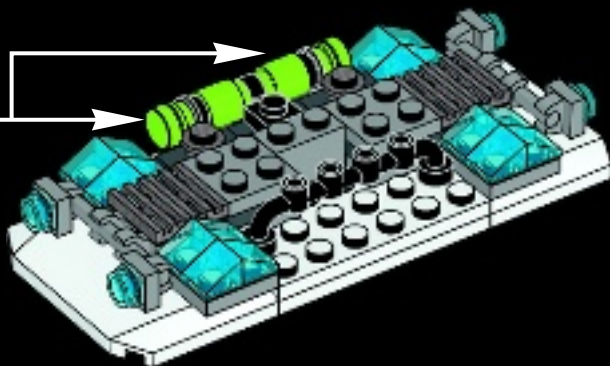

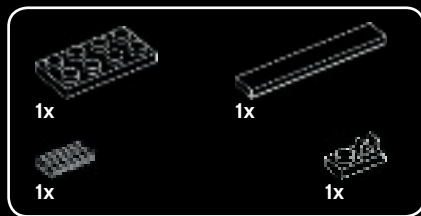

10

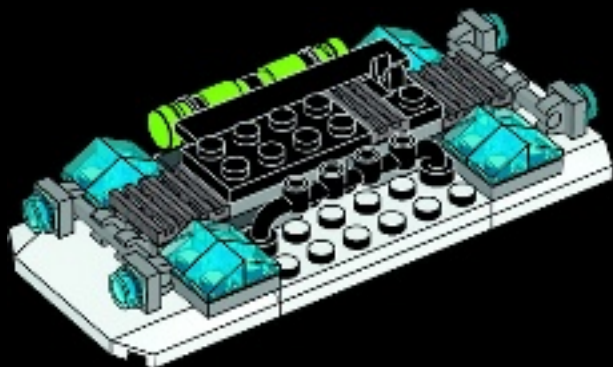

11

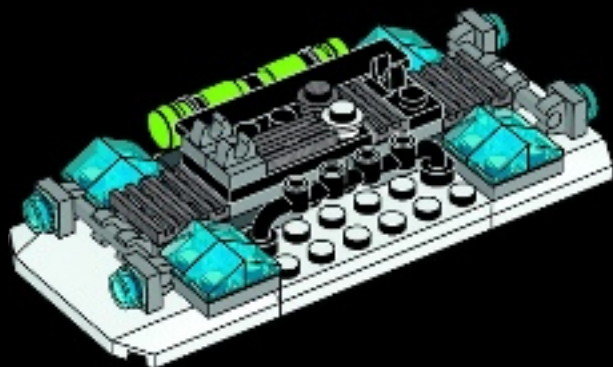

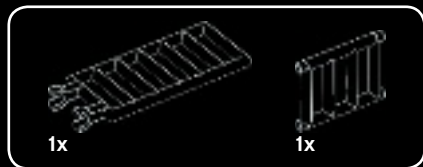

12

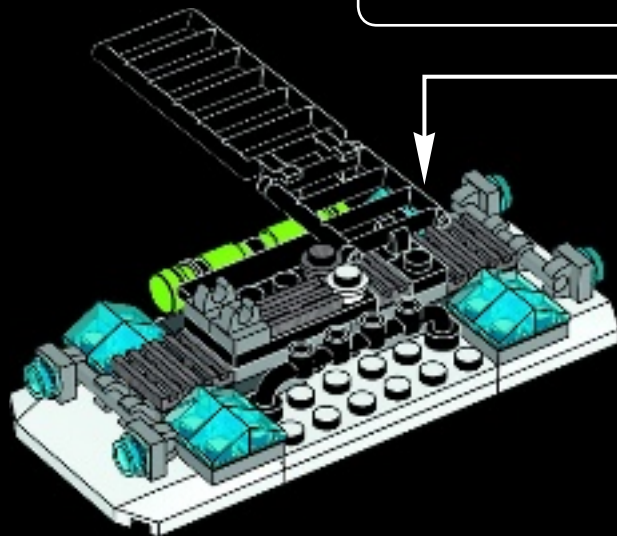
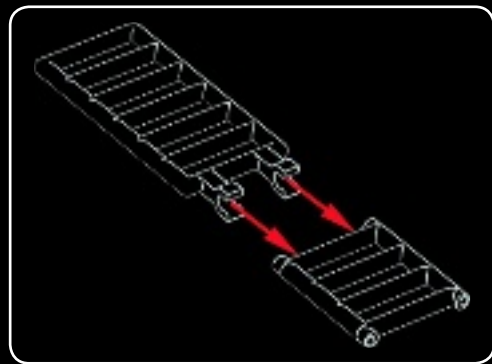



2x

13

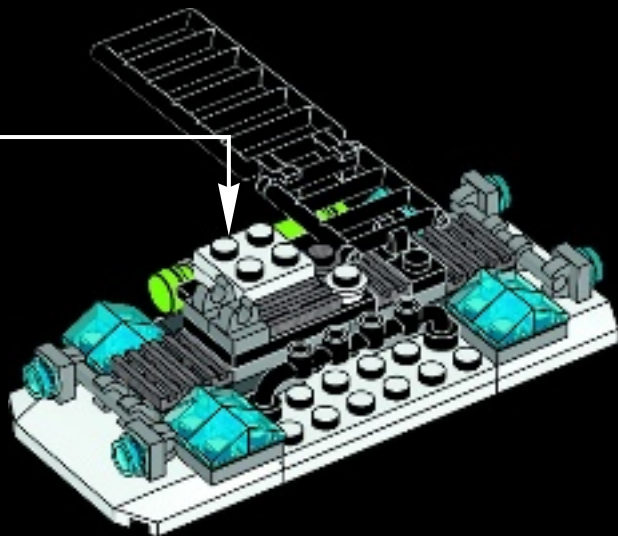
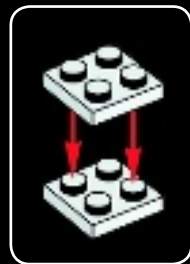



4x



4x



2x



2x

# 14

1



2



3



2x

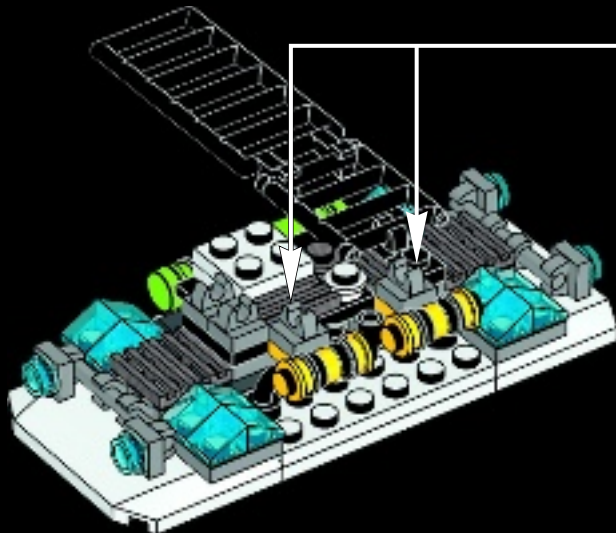

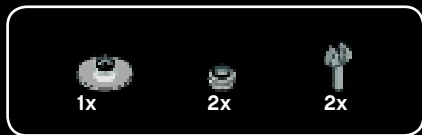

15

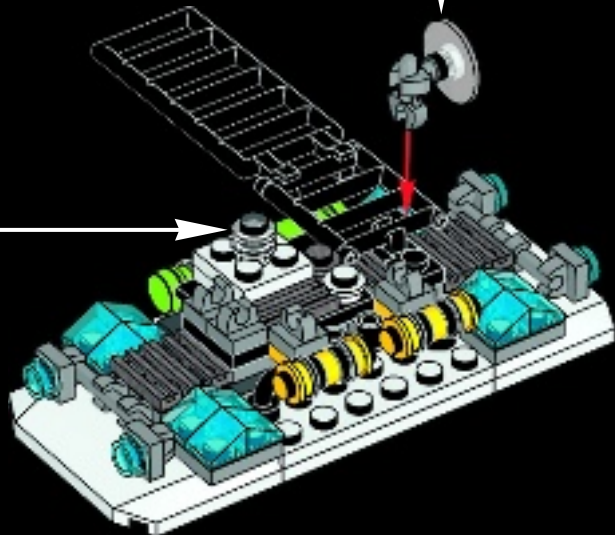
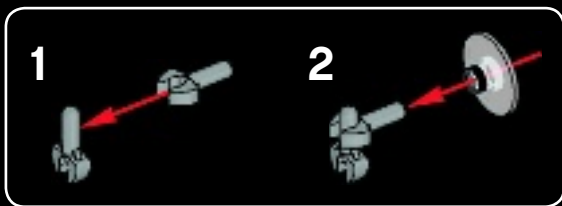



16

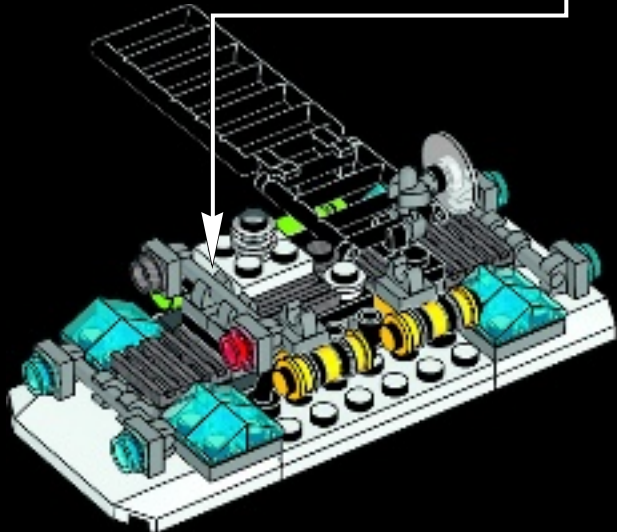
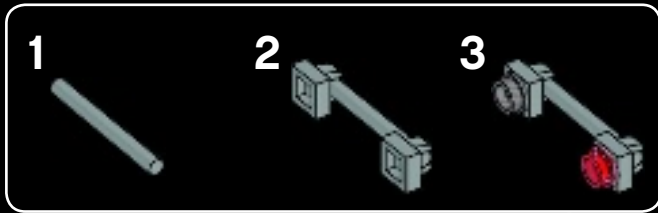





1x



1x

17

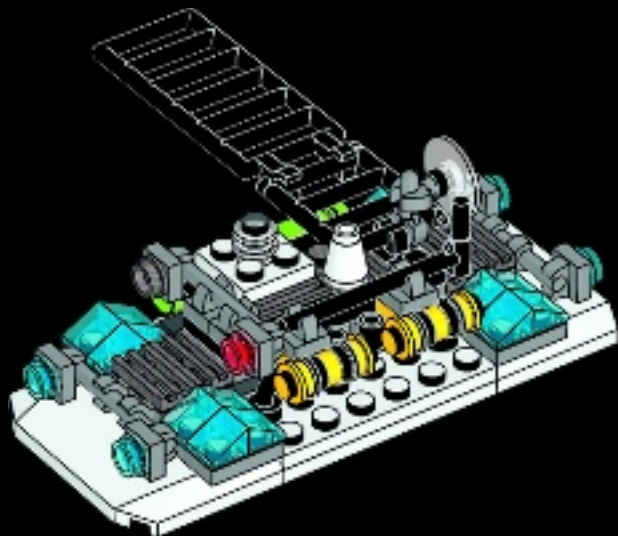



2x



1x



1x



1x



1x

# 18

1



2

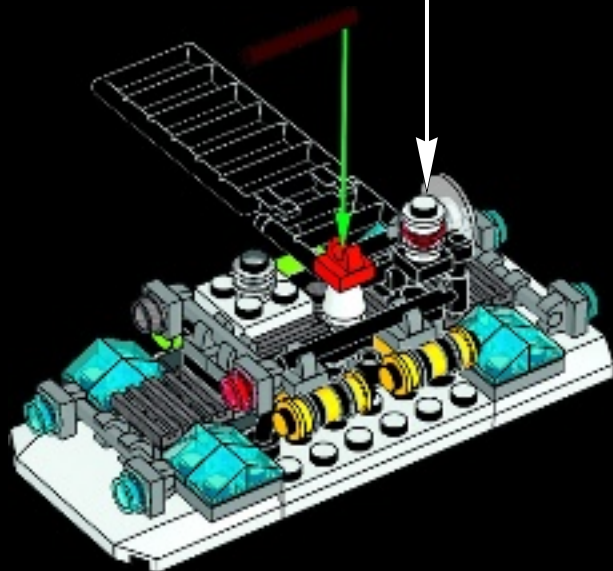

57

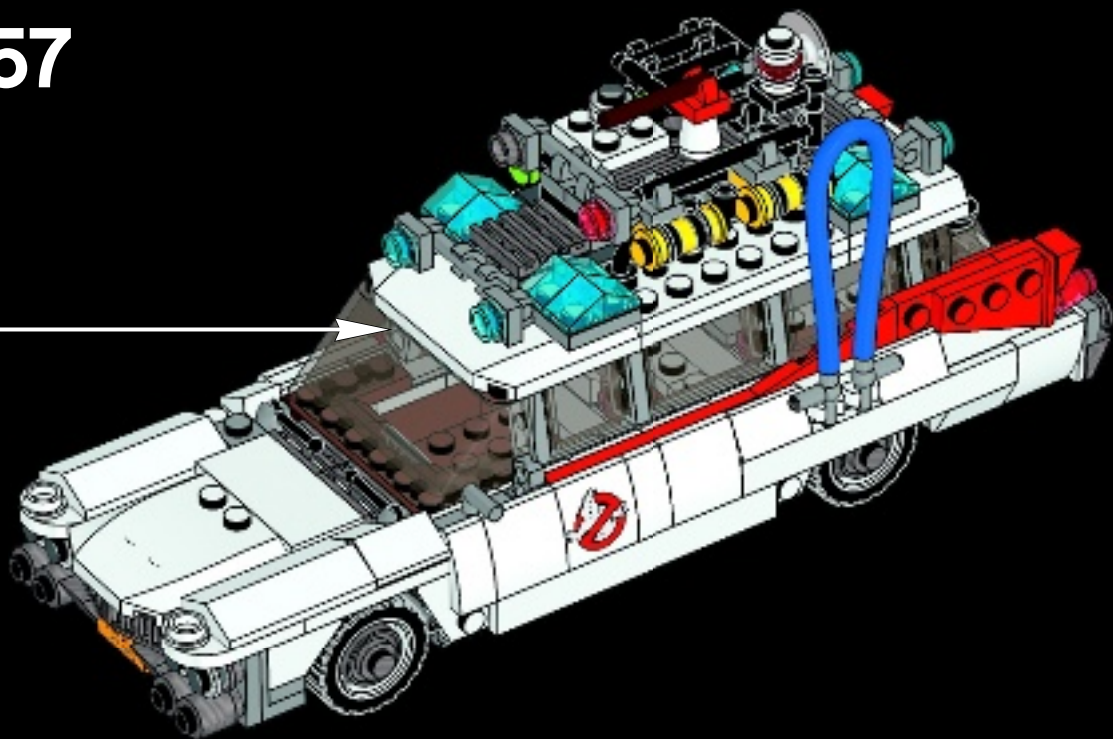

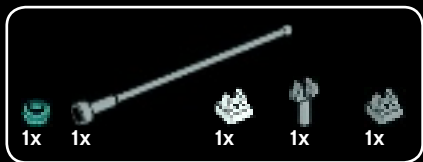

58

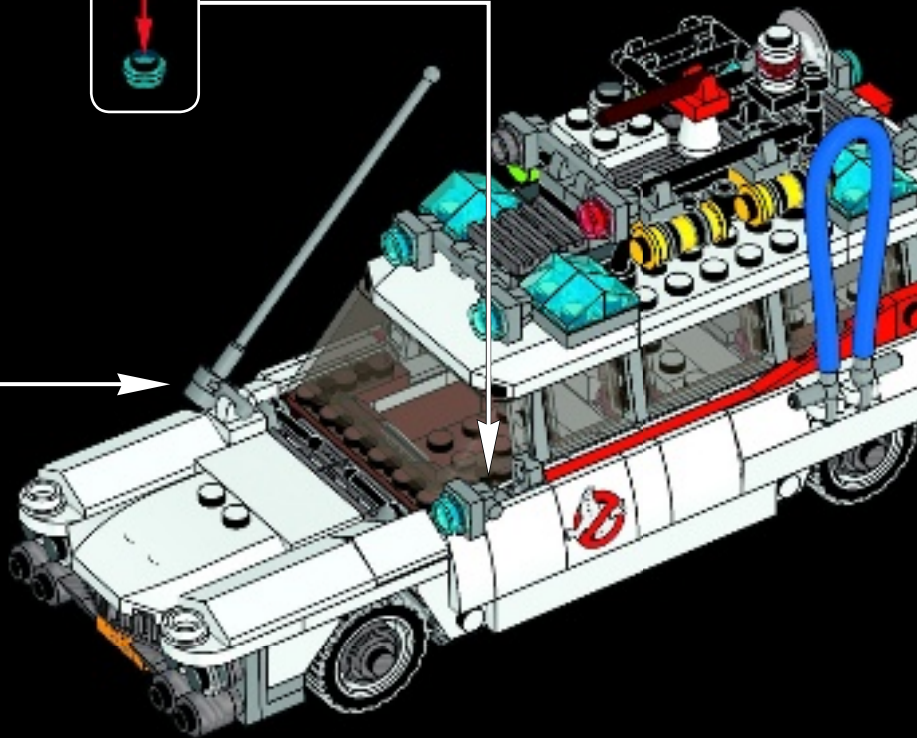
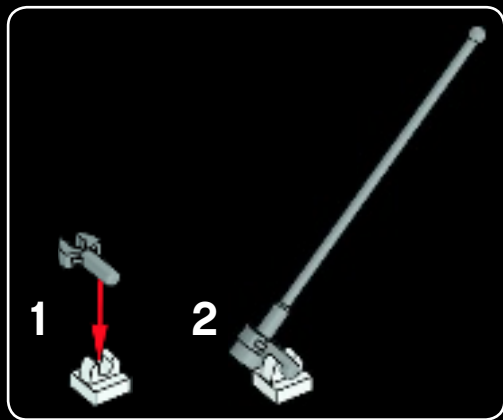

59

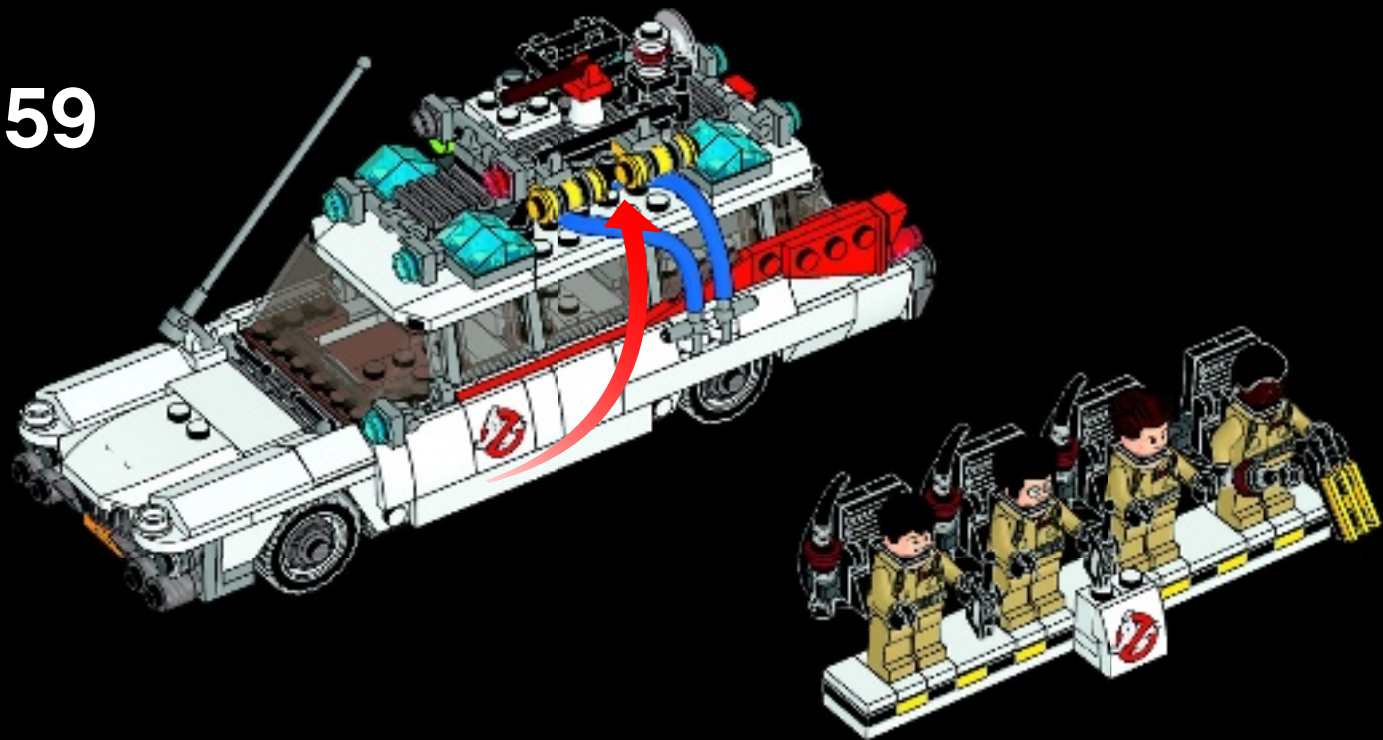

# A WORD FROM THE MODEL DESIGNERS

With the thirtieth anniversary of the blockbuster film approaching, Brent Waller, a 3D Environment Artist working in the video game industry, decided to celebrate the event by designing and building his rendition of the film's four ghost-busting characters and their iconic vehicle. Posted on the LEGO® Ideas website (then known as LEGO Cuusoo) in March 2013, it quickly gathered the 10,000 votes needed to qualify for the review process, and was declared a winning model at the start of 2014.

"The *Ectomobile* or *Ecto-1* is one of the most famous movie cars in the world, instantly recognizable even to those not familiar with the films. Decked out in all manner of ghost-catching equipment and an overabundance of sirens, I was sure it would catch the attention of any person, ghost, or demi-god in the vicinity!"



*Brent Waller*  
3D Artist

Once the model was chosen as the latest LEGO Ideas product, Marcos Bessa, a senior LEGO model designer, was given the task of transforming Brent's design into a true LEGO construction set. It was Marcos' first involvement with a LEGO Ideas project and with a background in the LEGO Fan Community himself, he enjoyed the challenge.

"Brent did a very good job with his model, but I had to ensure it had the proper stability and offered a good LEGO building experience. I kept the scale and used many of the same elements visible on the outside, which granted a similar overall look between Brent's model and the final product."



*Marcos Bessa Adam Corbally*

"It was great being a part of such an iconic LEGO product release. The first movie came out five years before I was even born, but I still watched it many times growing up and always loved it!"

For LEGO graphic designer, Adam Corbally, the biggest challenge was making each LEGO minifigure as individual as possible, while keeping it close to the reference from the films. "This was a rather challenging task due to such a small scale, but I think the final result works well."



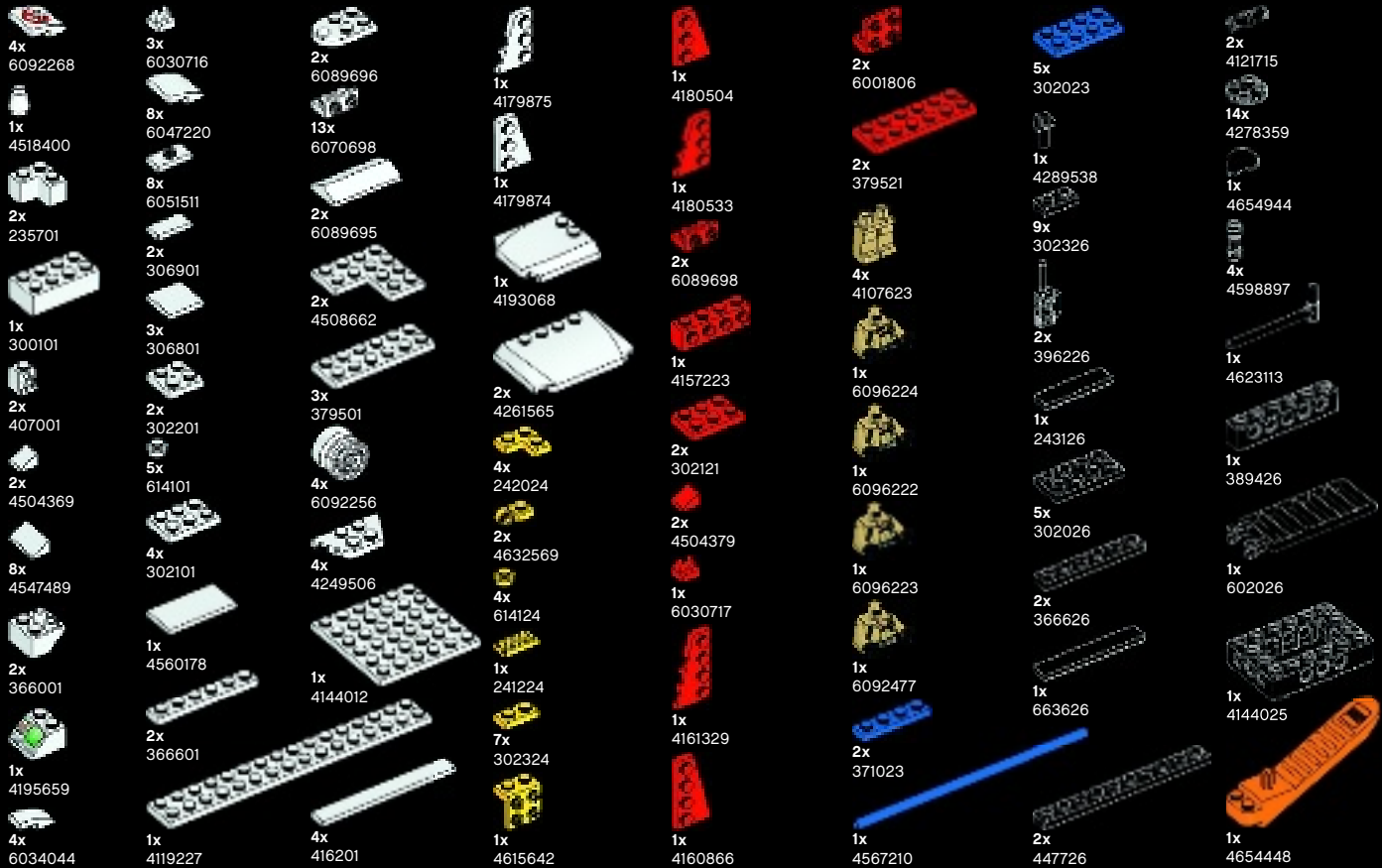

4x  
6092268

1x  
4518400

2x  
235701

1x  
300101

2x  
407001

2x  
4504369

8x  
4547489

2x  
366001

1x  
4195659

4x  
6034044

3x  
6030716

8x  
6047220

8x  
6051511

2x  
306901

3x  
306801

2x  
302201

5x  
614101

4x  
302101

1x  
4560178

2x  
366601

1x  
4119227

2x  
6089696

13x  
6070698

2x  
6089695

2x  
4508662

3x  
379501

4x  
6092256

4x  
4249506

1x  
4144012

4x  
416201

1x  
4179875

1x  
4179874

1x  
4193068

2x  
4261565

4x  
242024

2x  
4632569

4x  
614124

1x  
241224

7x  
302324

1x  
4615642

1x  
4180504

1x  
4180533

2x  
6089698

1x  
4157223

2x  
302121

2x  
4504379

1x  
6030717

1x  
4161329

1x  
4160866

2x  
6001806

2x  
379521

4x  
4107623

1x  
6096224

1x  
6096222

1x  
6096223

1x  
6092477

2x  
371023

1x  
4567210

5x  
302023

1x  
4289538

9x  
302326

2x  
396226

1x  
243126

5x  
302026

2x  
366626

1x  
663626

2x  
447726

2x  
4121715

14x  
4278359

1x  
4654944

4x  
4598897

1x  
4623113

1x  
389426

1x  
602026

1x  
4144025

1x  
4654448



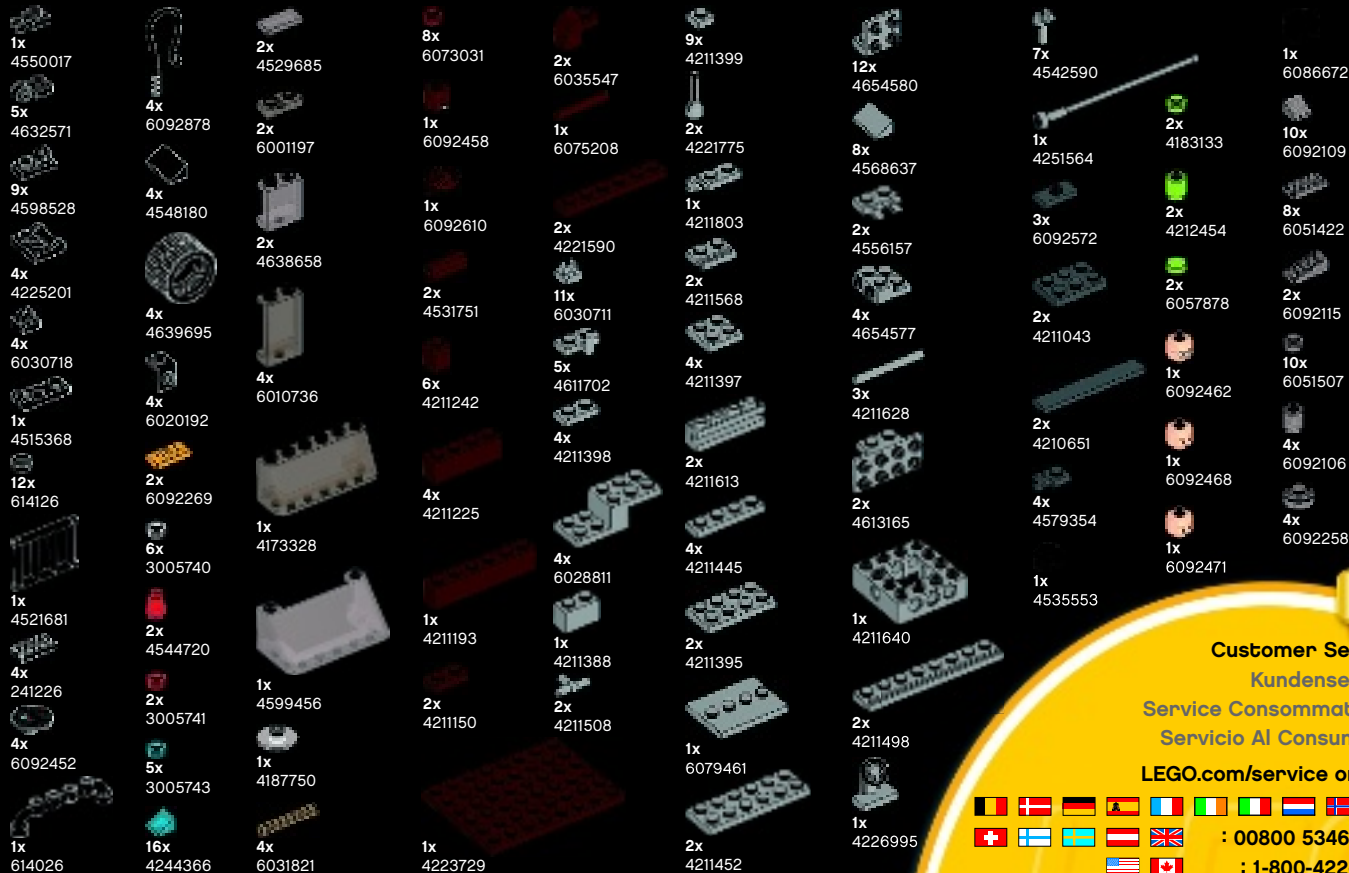

**Customer Service**  
**Kundenservice**  
**Service Consommateurs**  
**Servicio Al Consumidor**  
**LEGO.com/service or dial**



**: 00800 5346 5555**  
**: 1-800-422-5346**

# LEGO IDEAS: A PLAYGROUND FOR INNOVATIVE LEGO® IDEAS

Do you have an exciting idea for a LEGO® model? Then why not make it into a LEGO Ideas project? You can share your product concept on ideas.LEGO.com and see what other people think about it.

If your project gains 10,000 supporters, it will automatically qualify for the LEGO Review. This is where we take an in-depth look at the most popular projects and carefully evaluate them to discover the idea with the most potential. If your project makes it through the review, it will become an official LEGO product.

There are already over 250,000 active users and over 7000 projects on the LEGO Ideas website, and 6 products have already been launched. So take a look, sign up, and support your favorite ideas, or even better: upload your own project!





21109





# WIN!

Go to [LEGO.com/productfeedback](http://LEGO.com/productfeedback) to fill out a survey for a chance to win a cool LEGO® Product.

No purchase necessary.  
Open to all residents where not prohibited.



## LEGO.com/productfeedback

### GEWINNE!

Nimm an der Umfrage auf [LEGO.com/productfeedback](http://LEGO.com/productfeedback) teil und hab die Chance ein cooles LEGO® Produkt zu gewinnen! Die Teilnahme am Gewinnspiel führt zu keinerlei Kaufverpflichtungen. Teilnahme in allen nicht ausgeschlossenen Ländern möglich.

 [LEGO.com](http://LEGO.com)

6115703

### WIN!

Ga naar [LEGO.com/productfeedback](http://LEGO.com/productfeedback), vul een enquêteformulier in en maak kans op een cool LEGO® product. Geen aankoopverplichting. Ledereen mag deelnemen, uitgezonderd ingezetenden van landen waar een enquêteverbod geldt.

### GAGNE!

Visite [LEGO.com/productfeedback](http://LEGO.com/productfeedback) pour répondre à un questionnaire et avoir une chance de gagner un produit LEGO® très cool ! Aucune obligation d'achat. Ouvert à tous les résidents des pays autorisés.

### 当てよう!

[LEGO.com/productfeedback](http://LEGO.com/productfeedback) にアクセスして、アンケートにご記入ください。当選者にはレゴ®製品を差し上げます。お買い上げの必要はありません。禁止されていない限り、すべての皆様にご利用いただけます。

LEGO and the LEGO logo are trademarks of the LEGO Group. ©2014 The LEGO Group.  
© 2014 Columbia Pictures Industries, Inc. All rights reserved.