



STAR WARS



7752



1

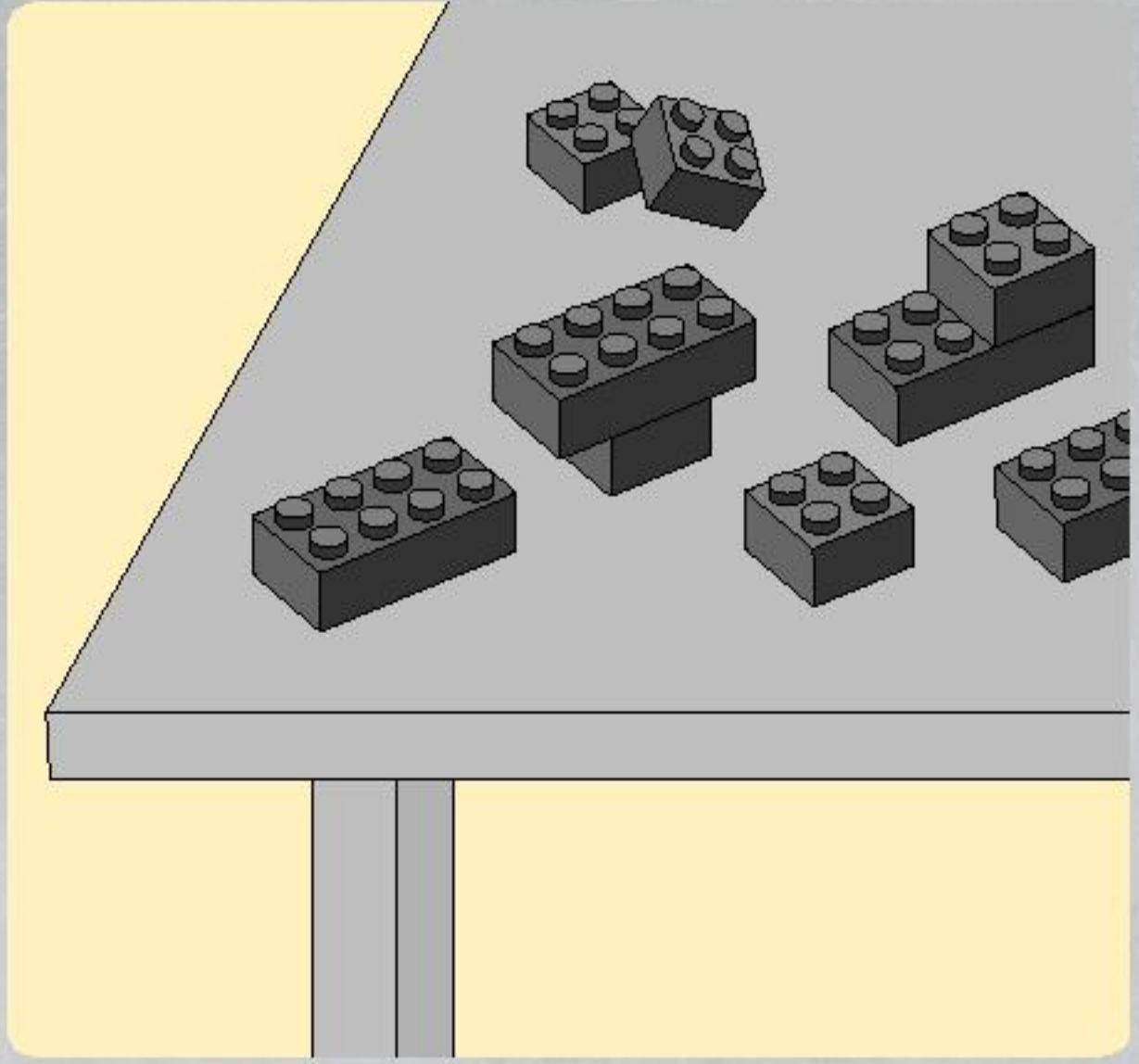
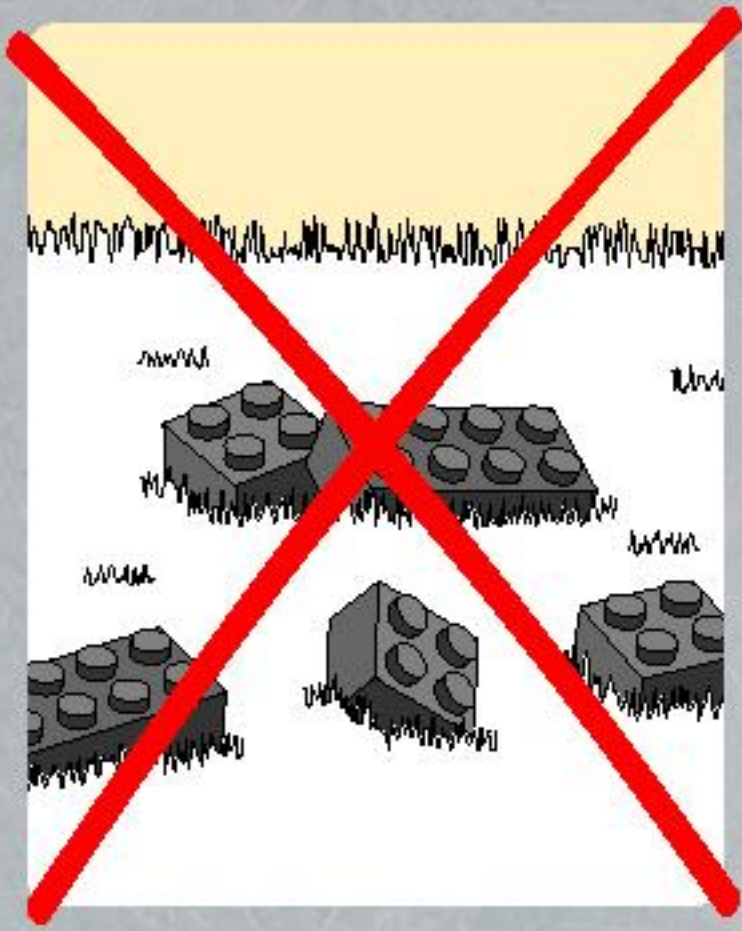

2

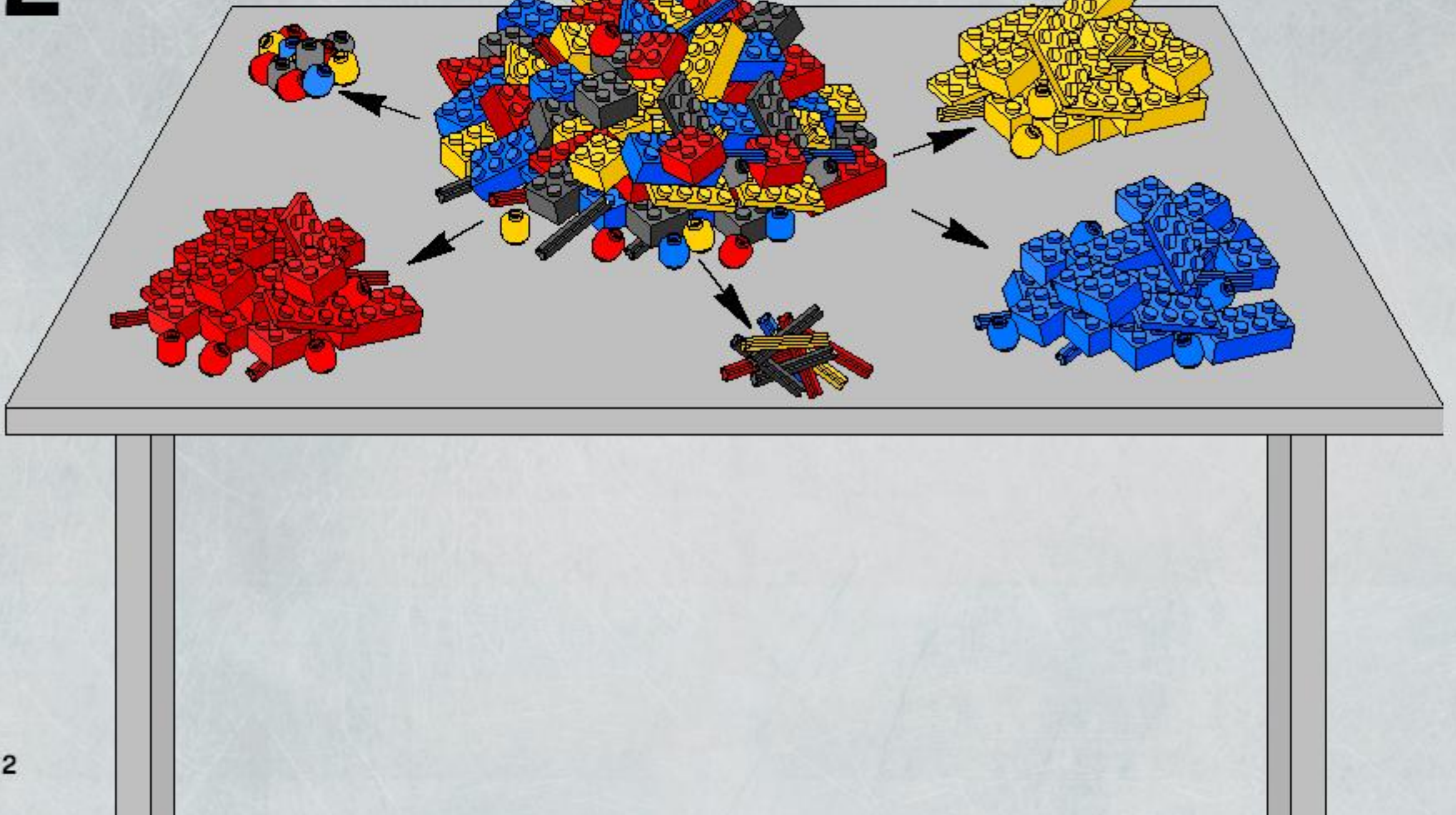

3

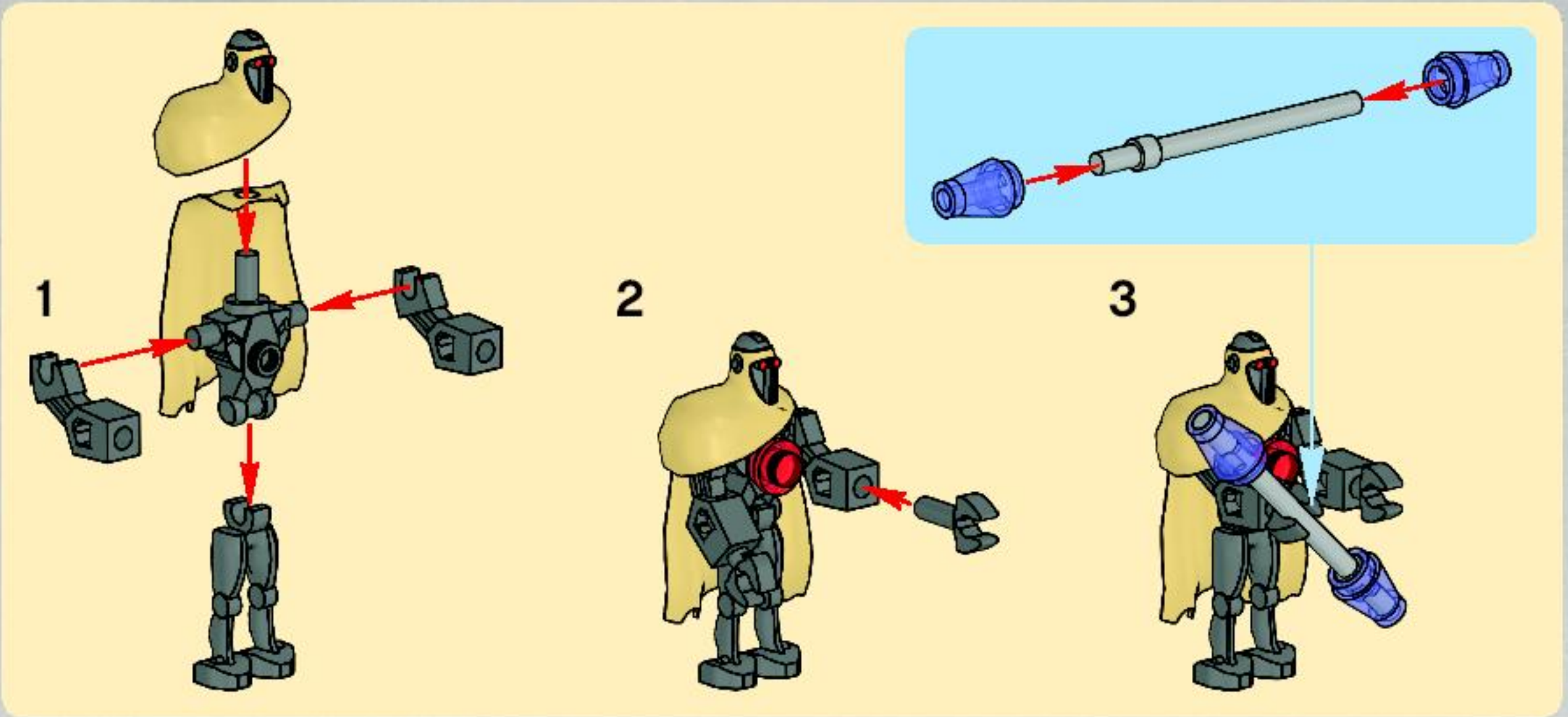
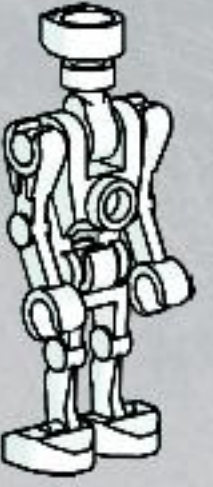
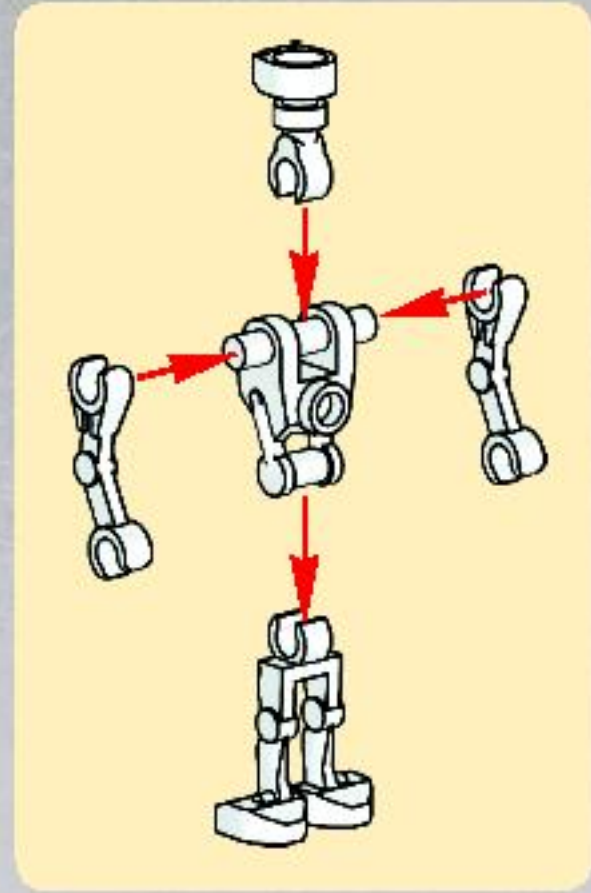
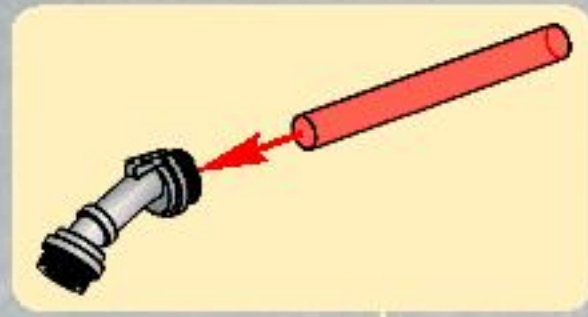

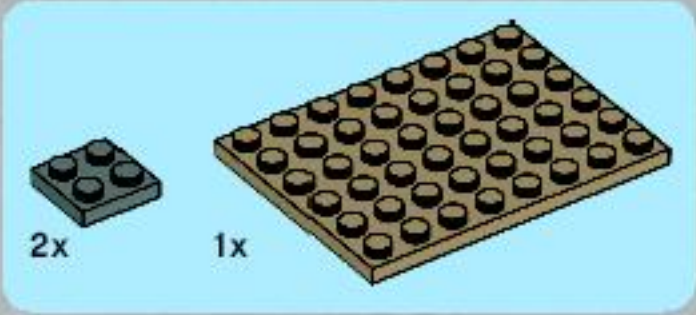

1

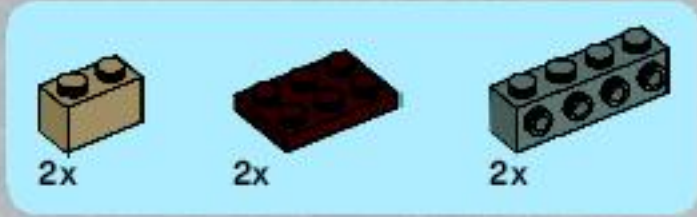
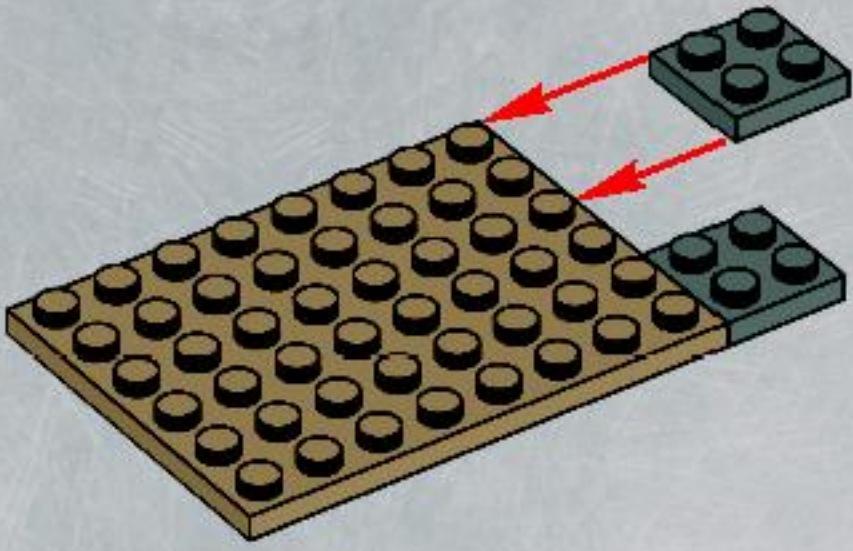

3

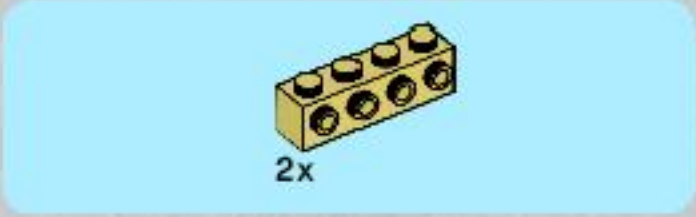
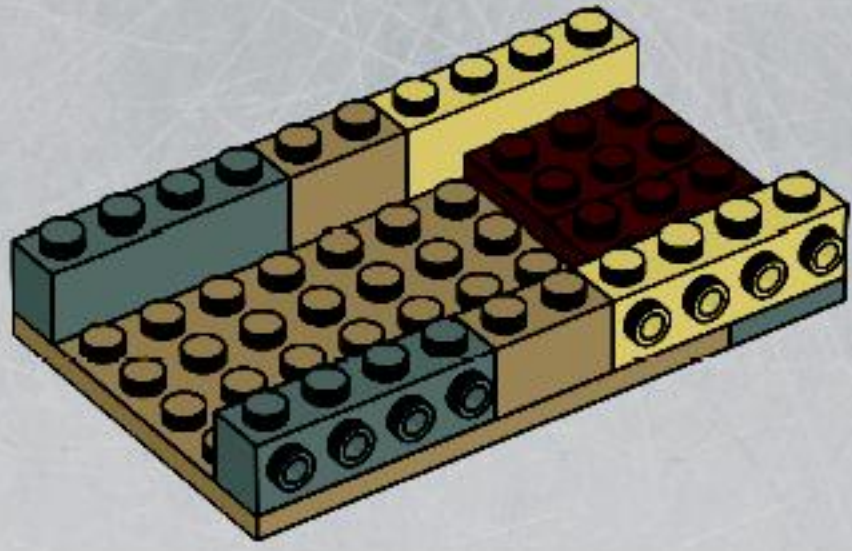

2

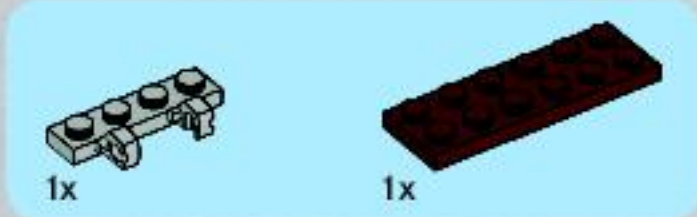
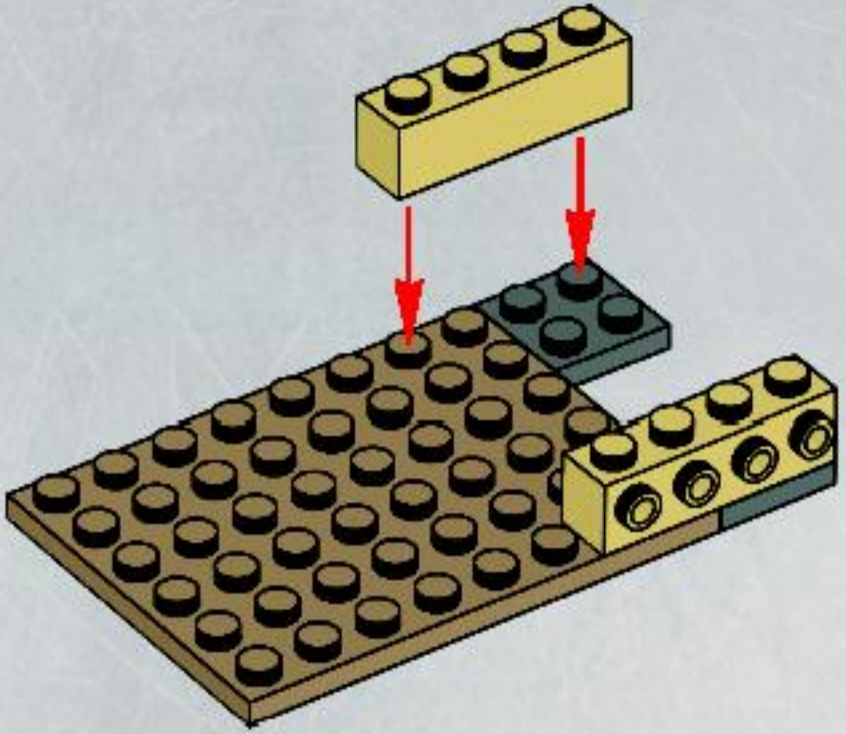

4

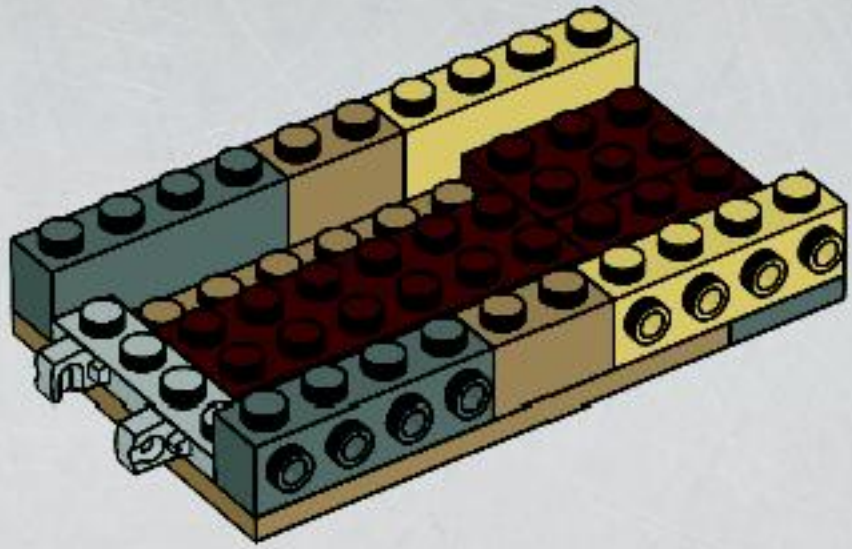



5

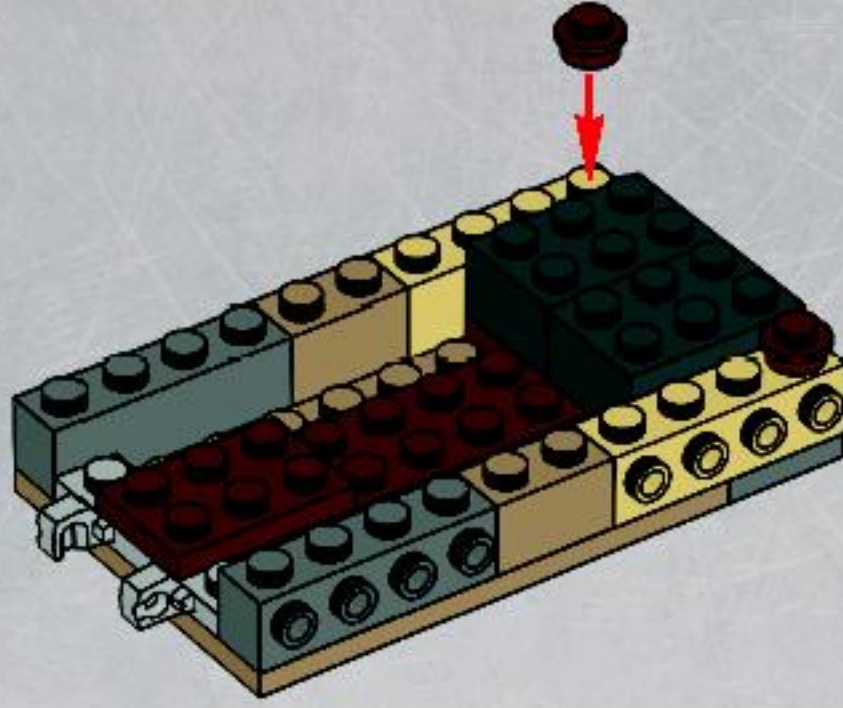

6

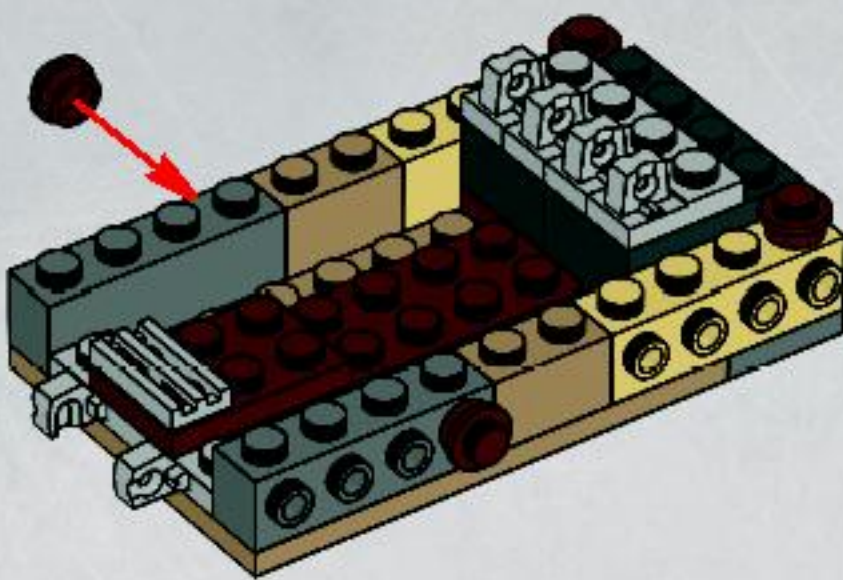

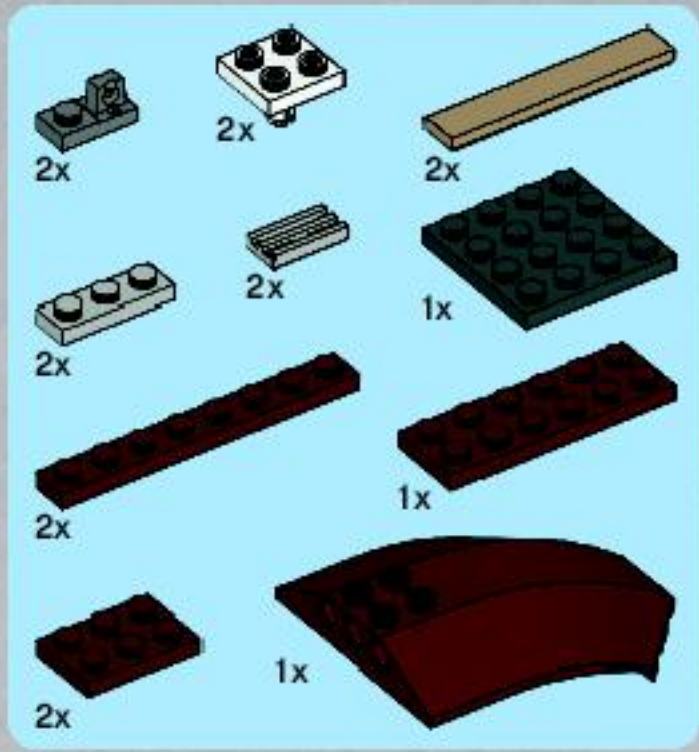

7

1

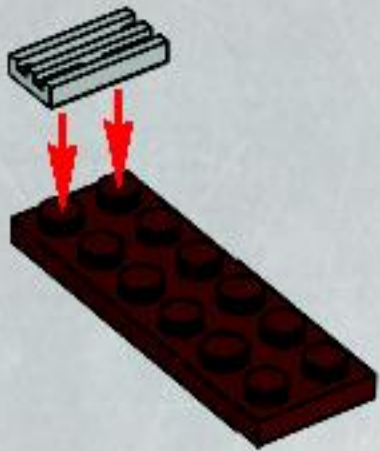

2

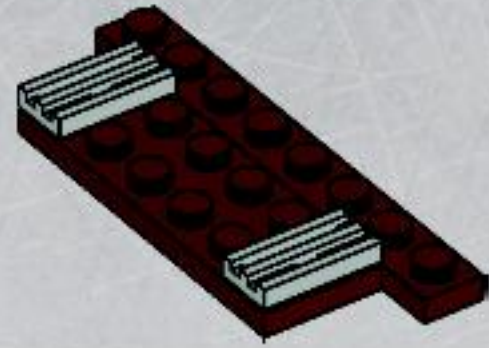

3

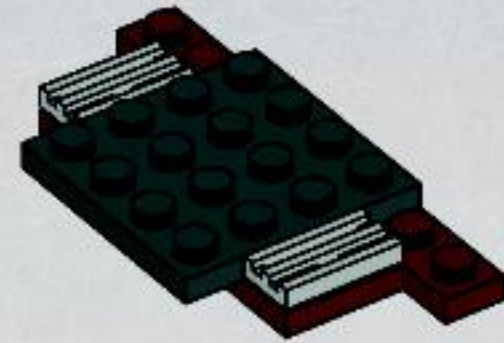

4

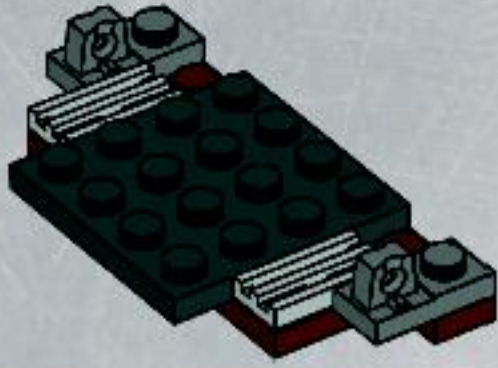

6

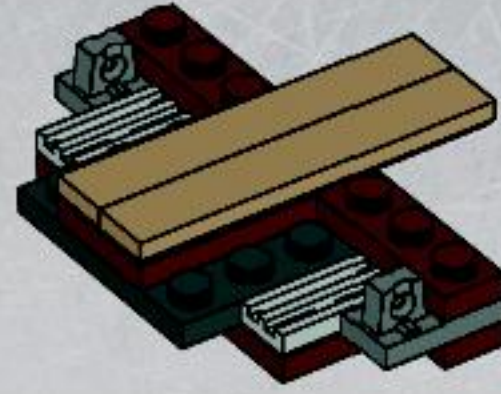

5

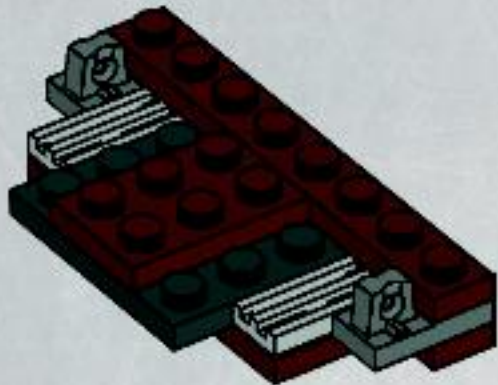

7

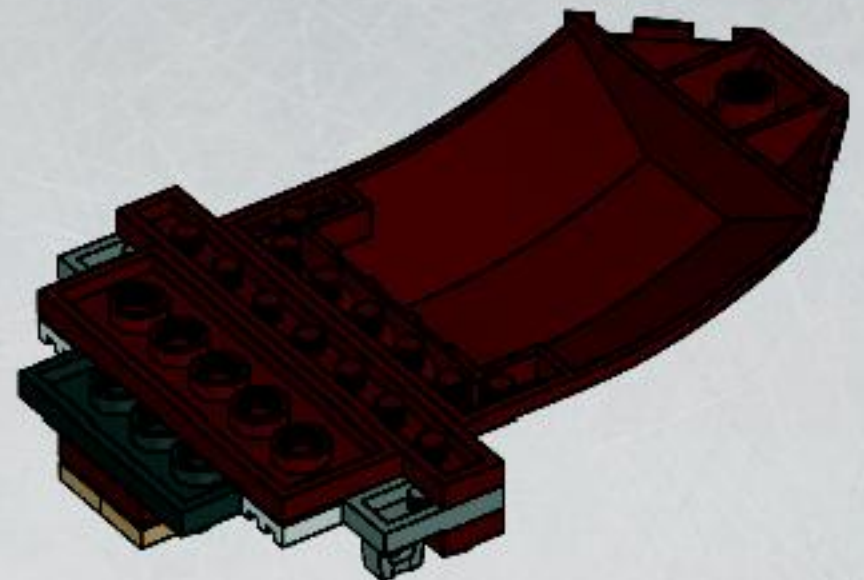

8

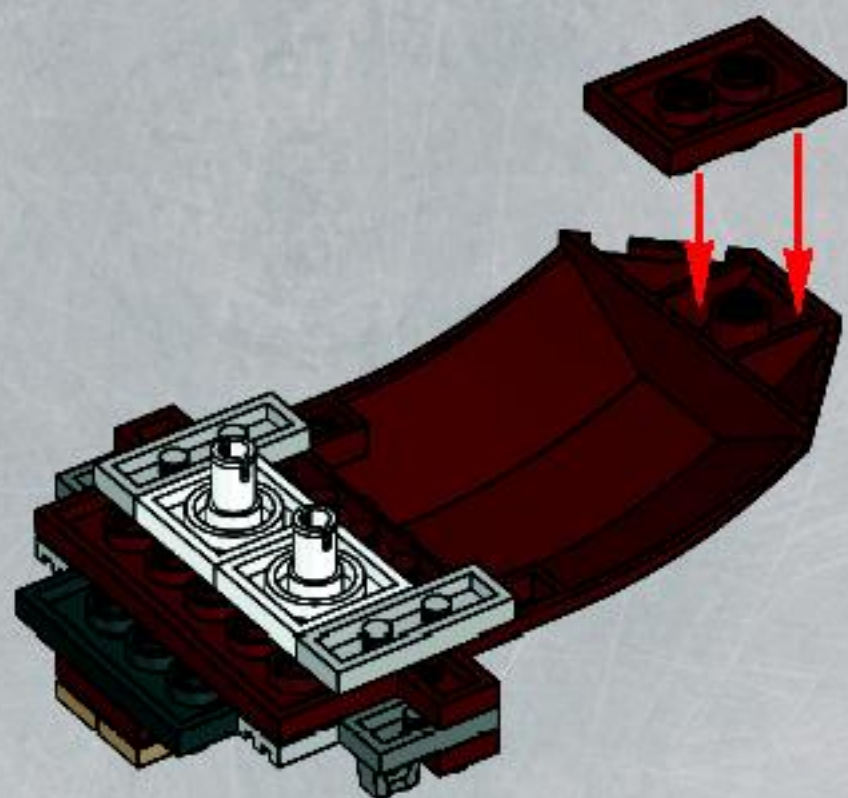

9

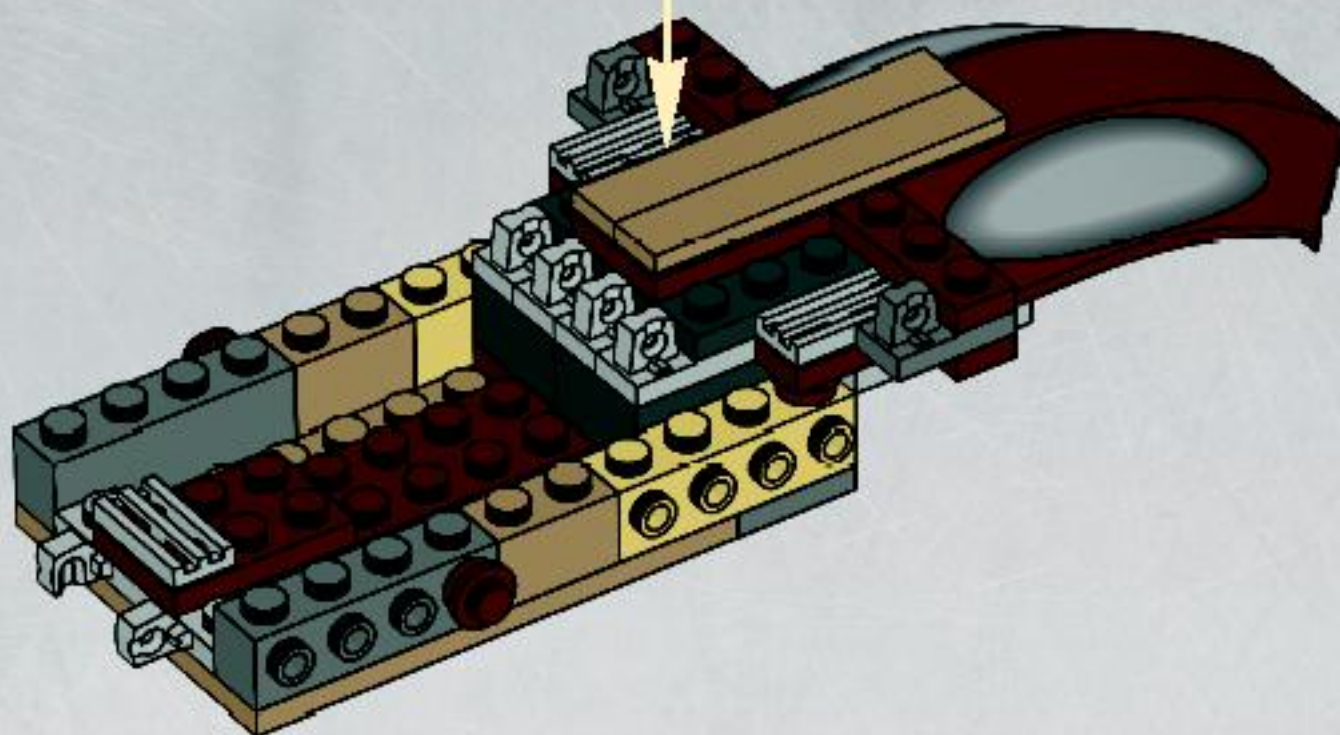
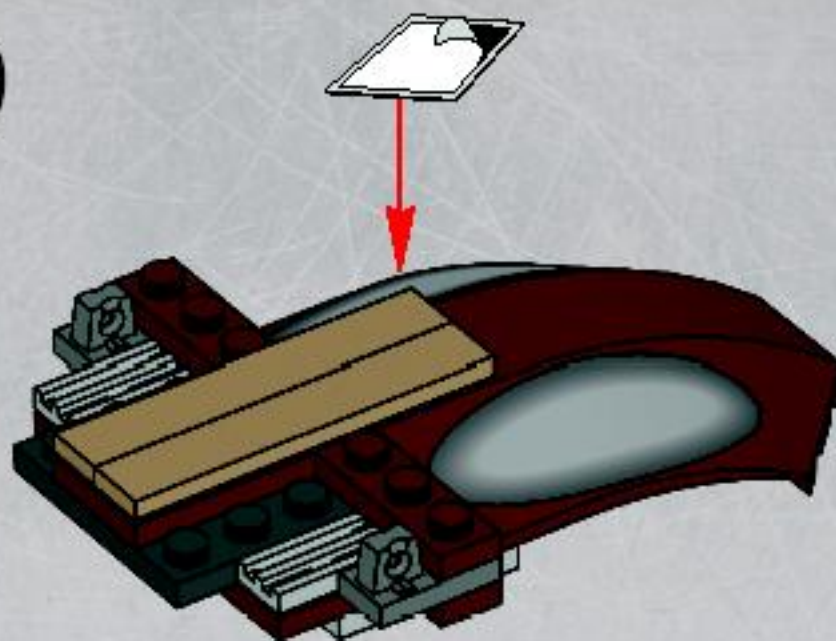

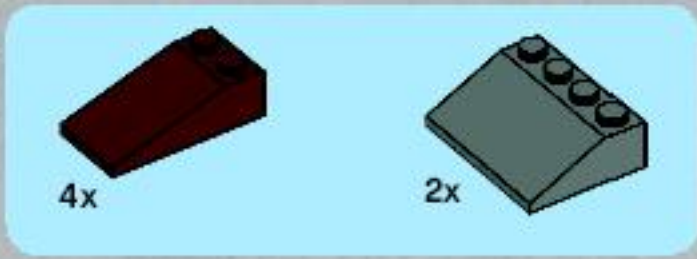

8

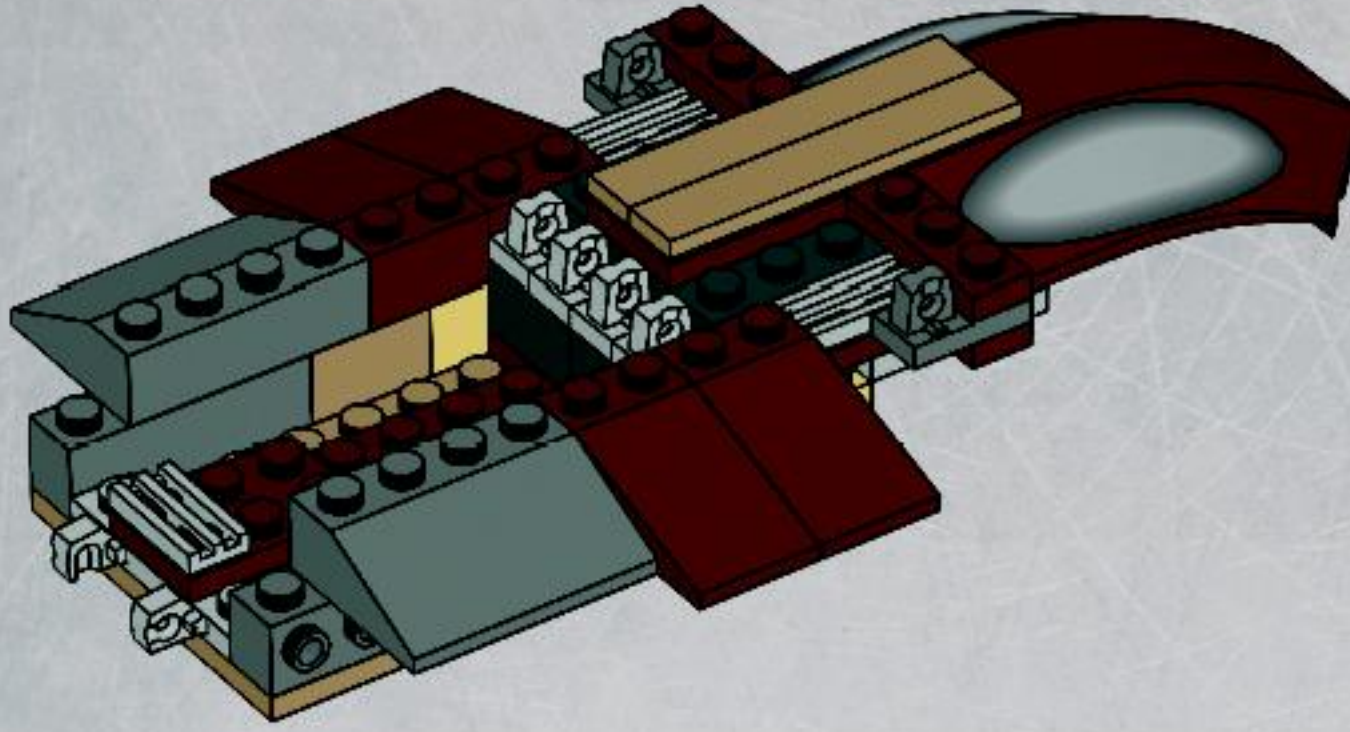

9

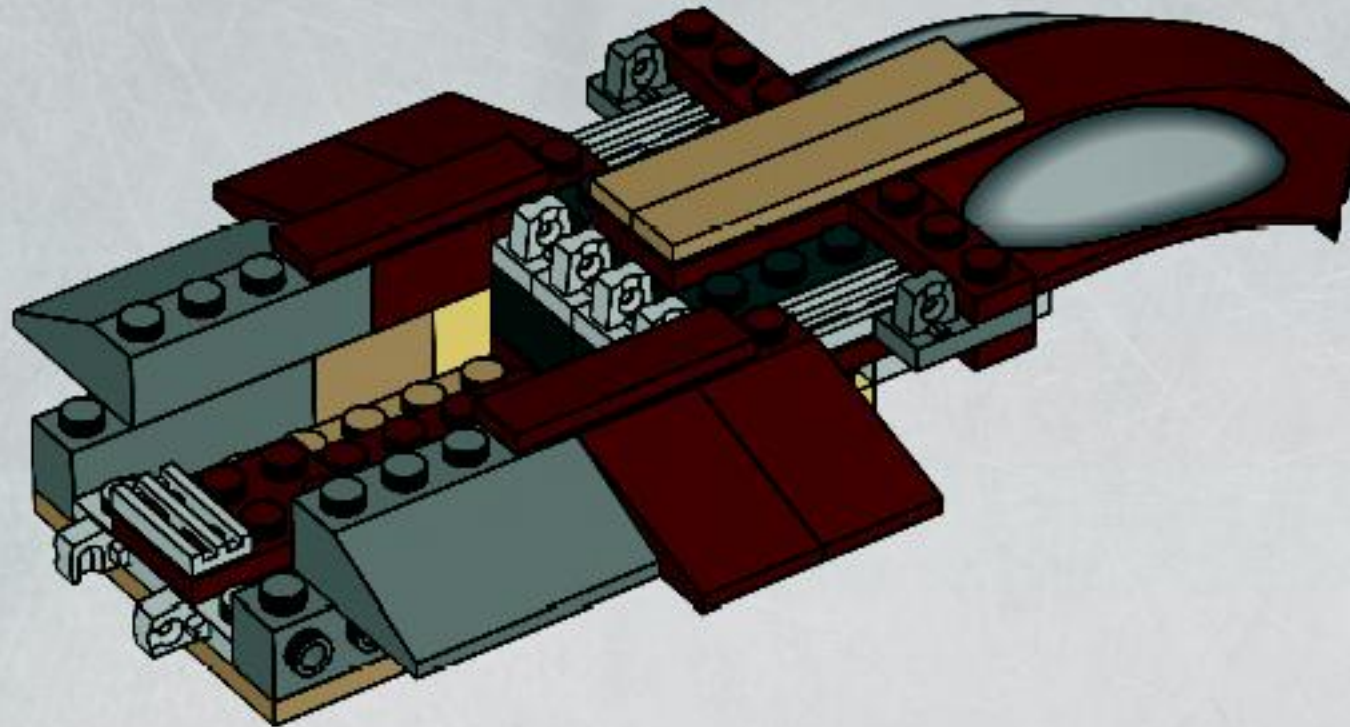

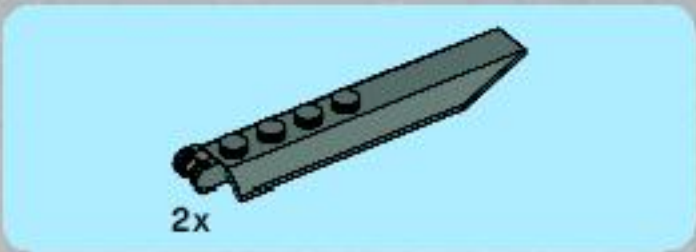

10

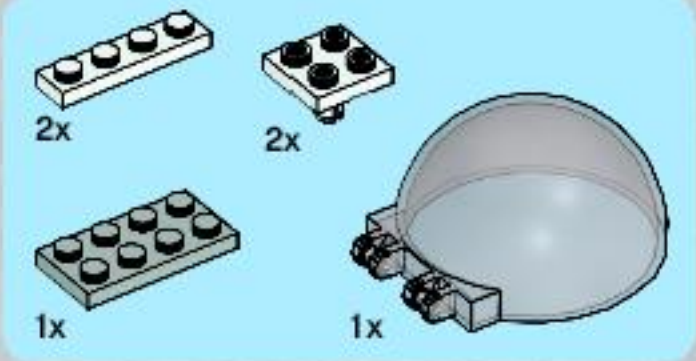
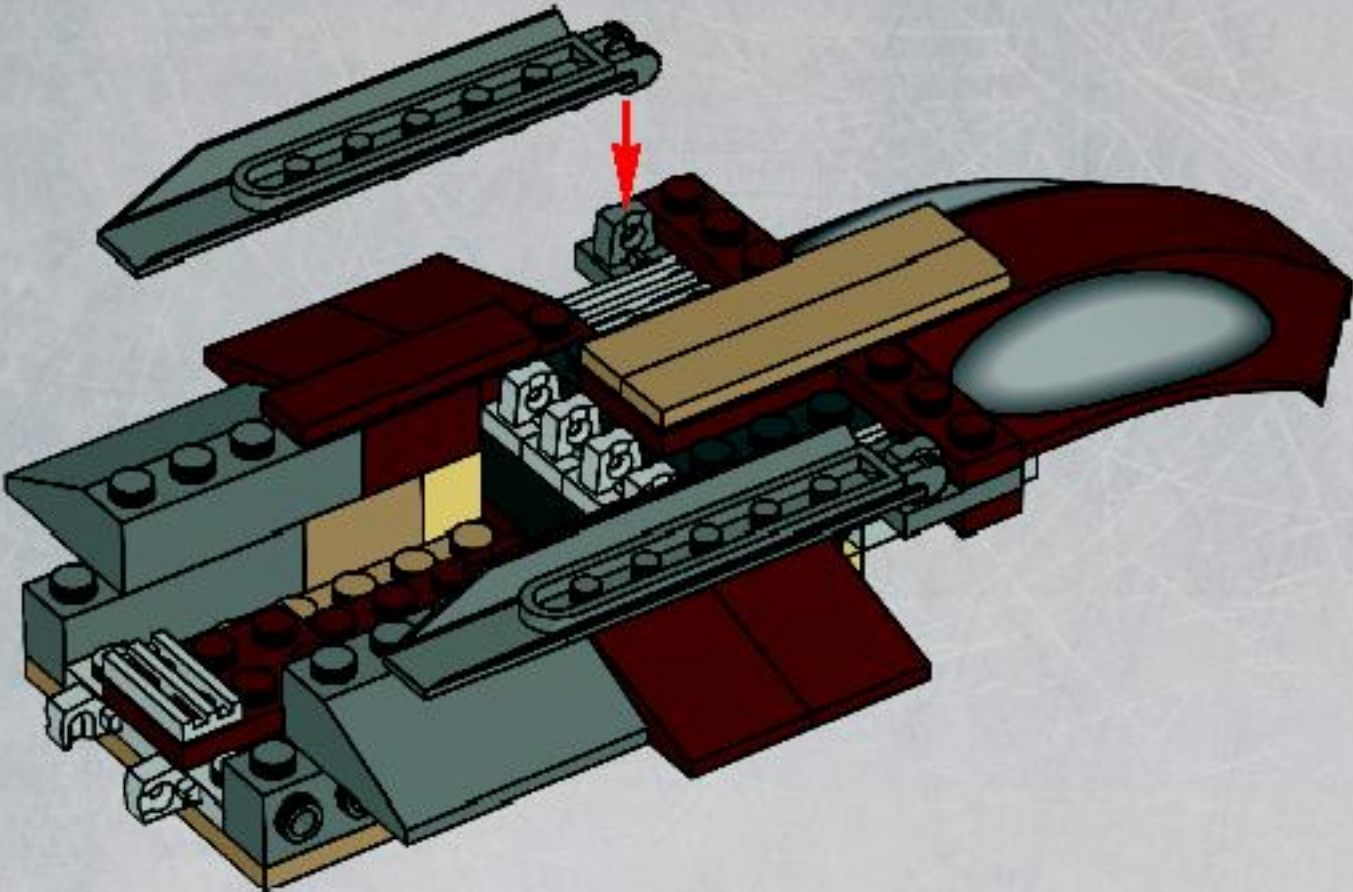

11

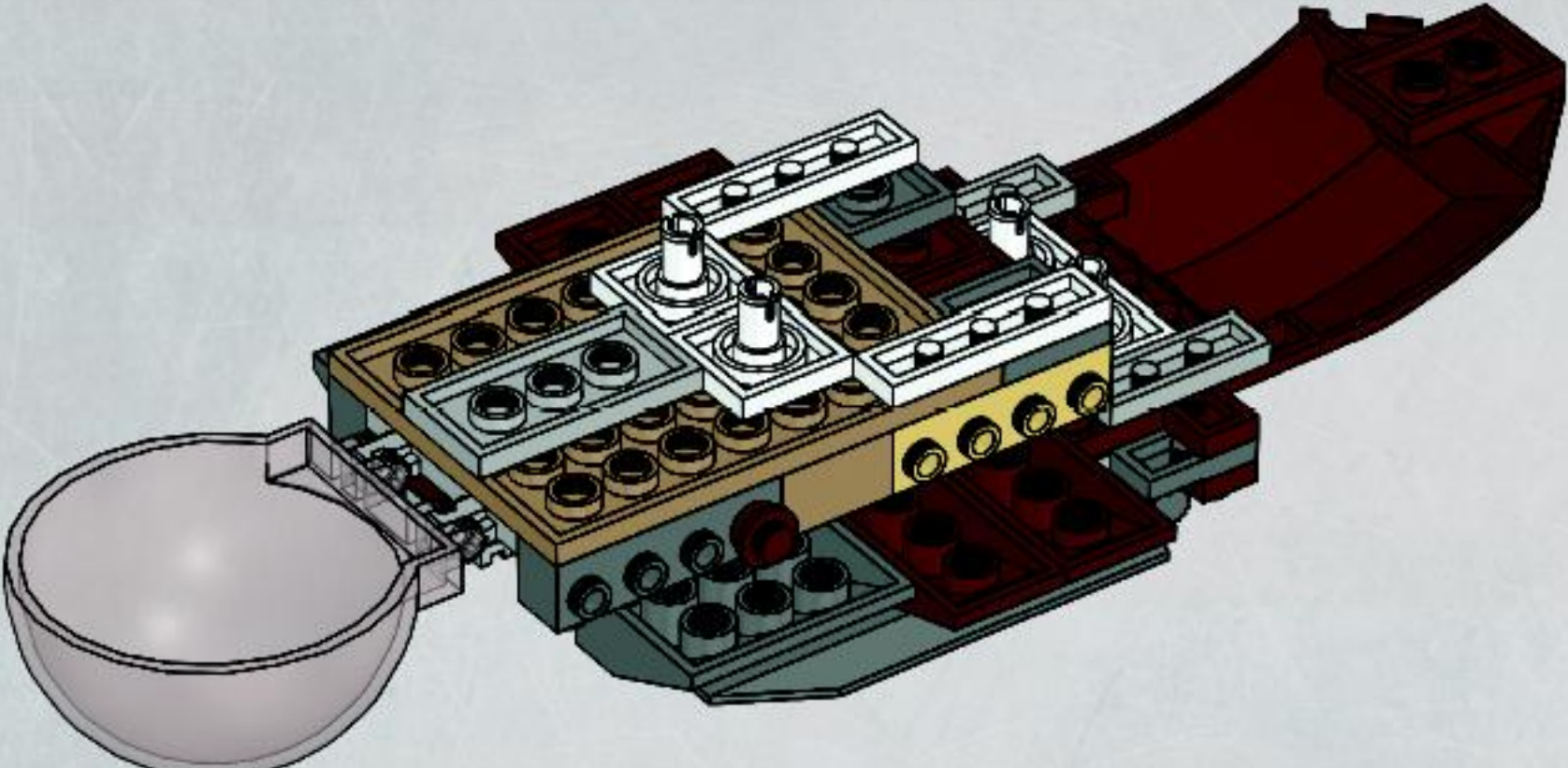

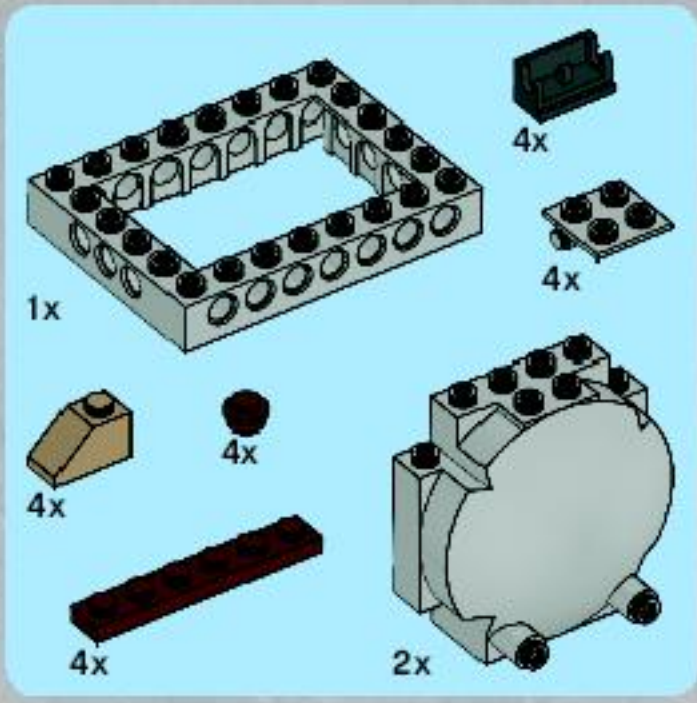

12

1

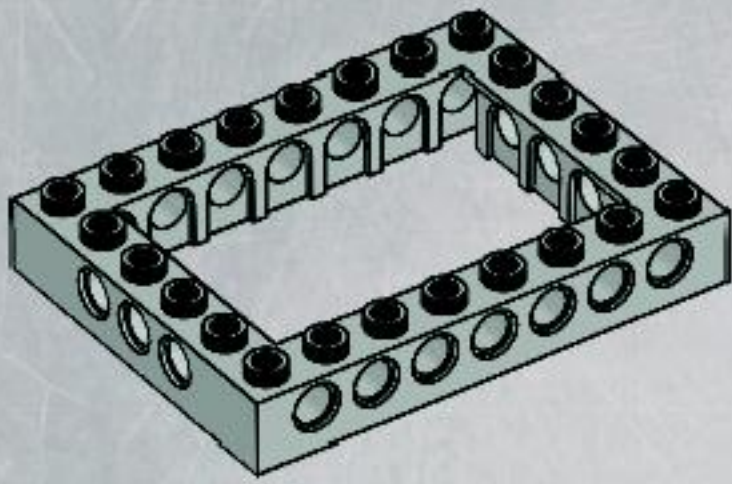

3

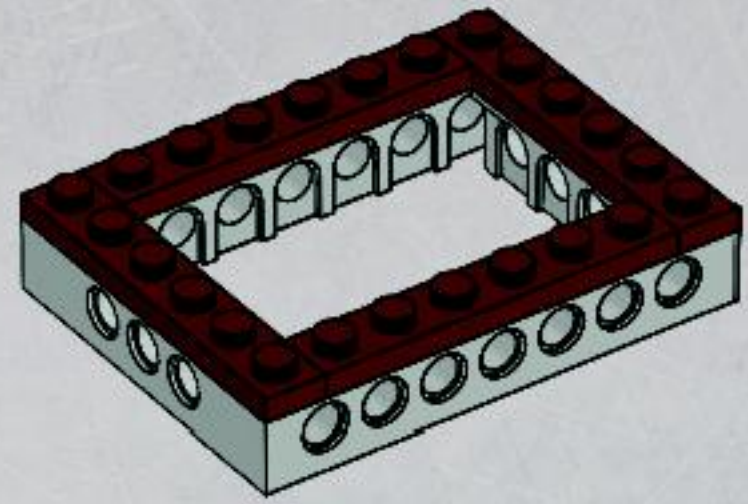

2

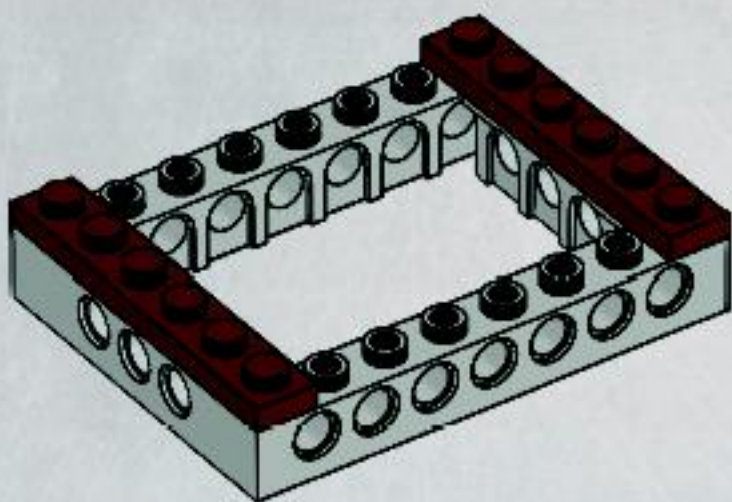

4

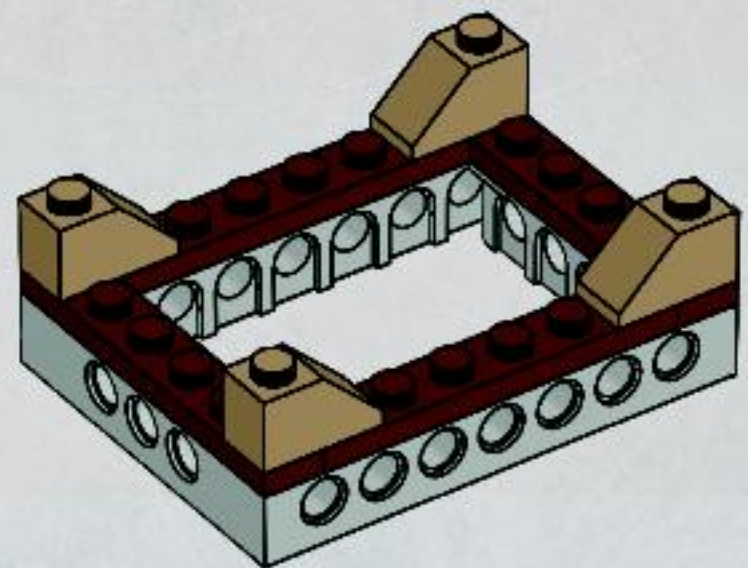

5

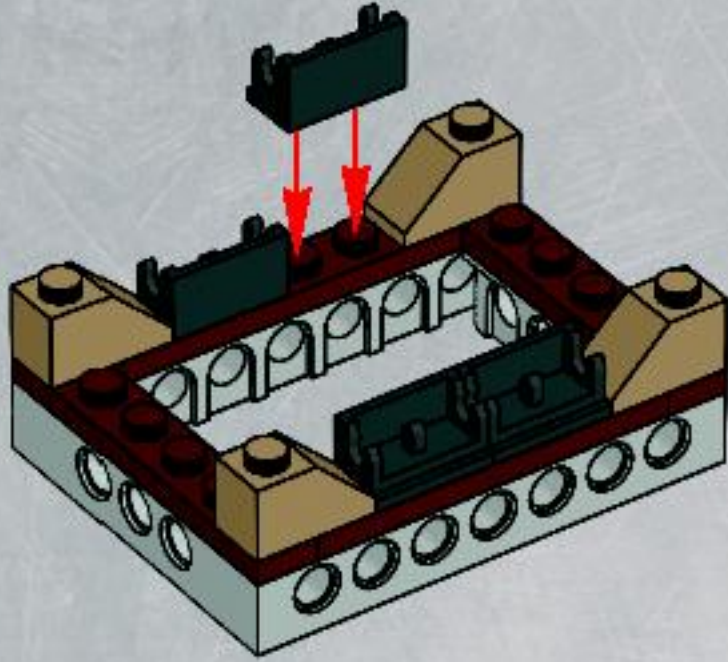

6

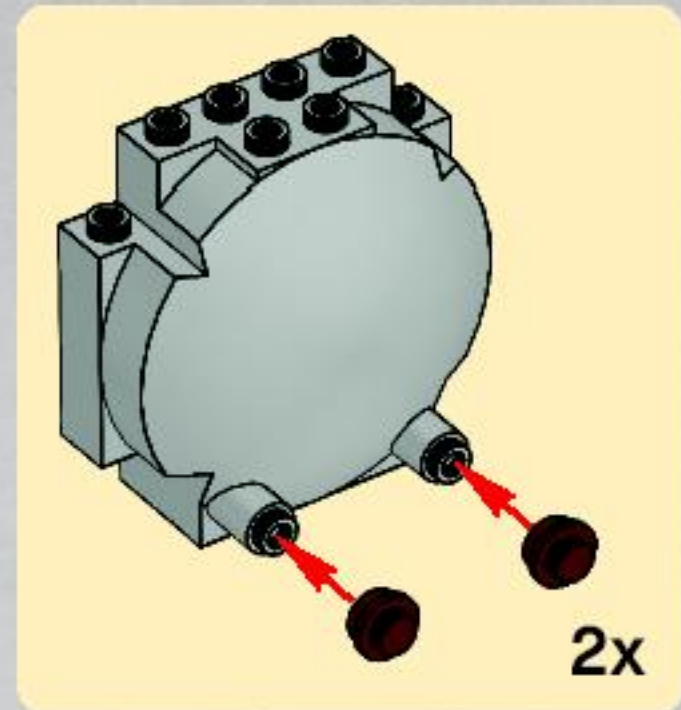
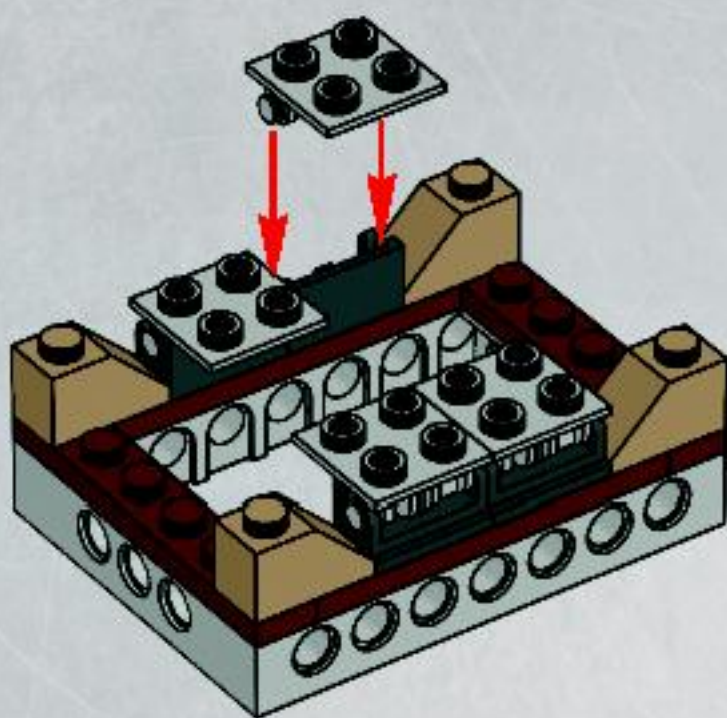

7

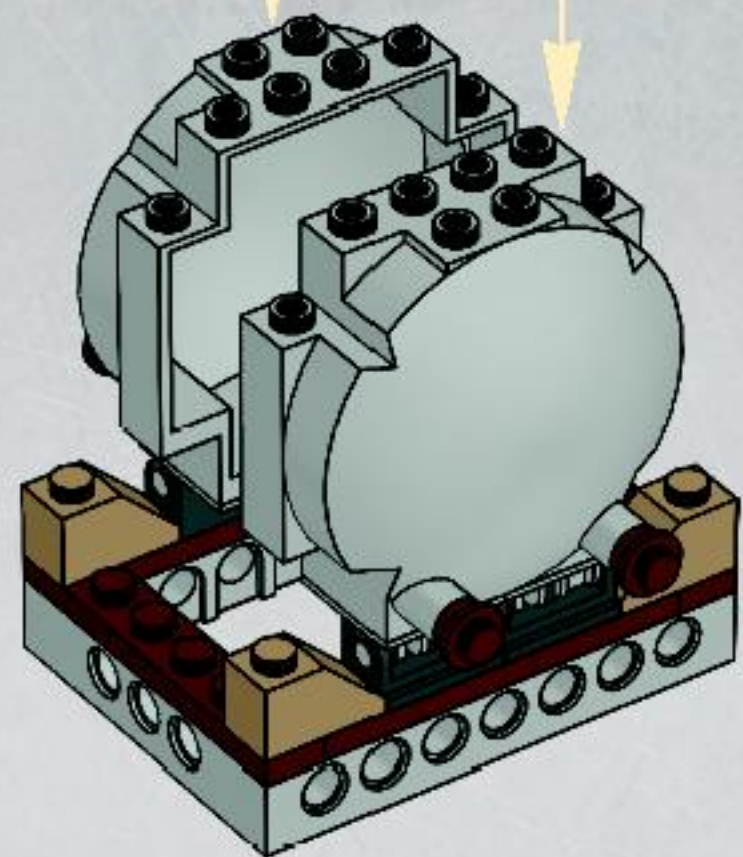

8

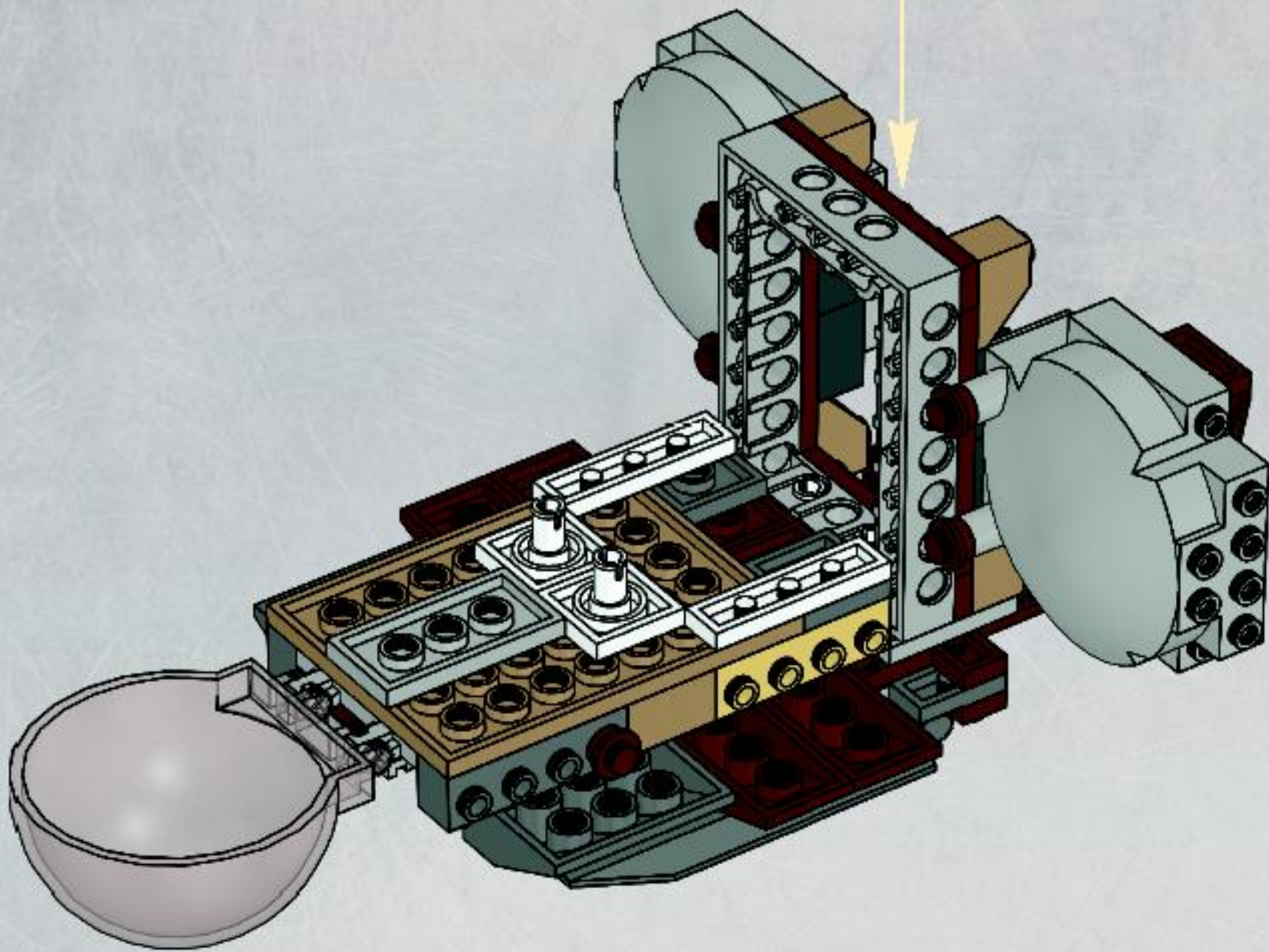
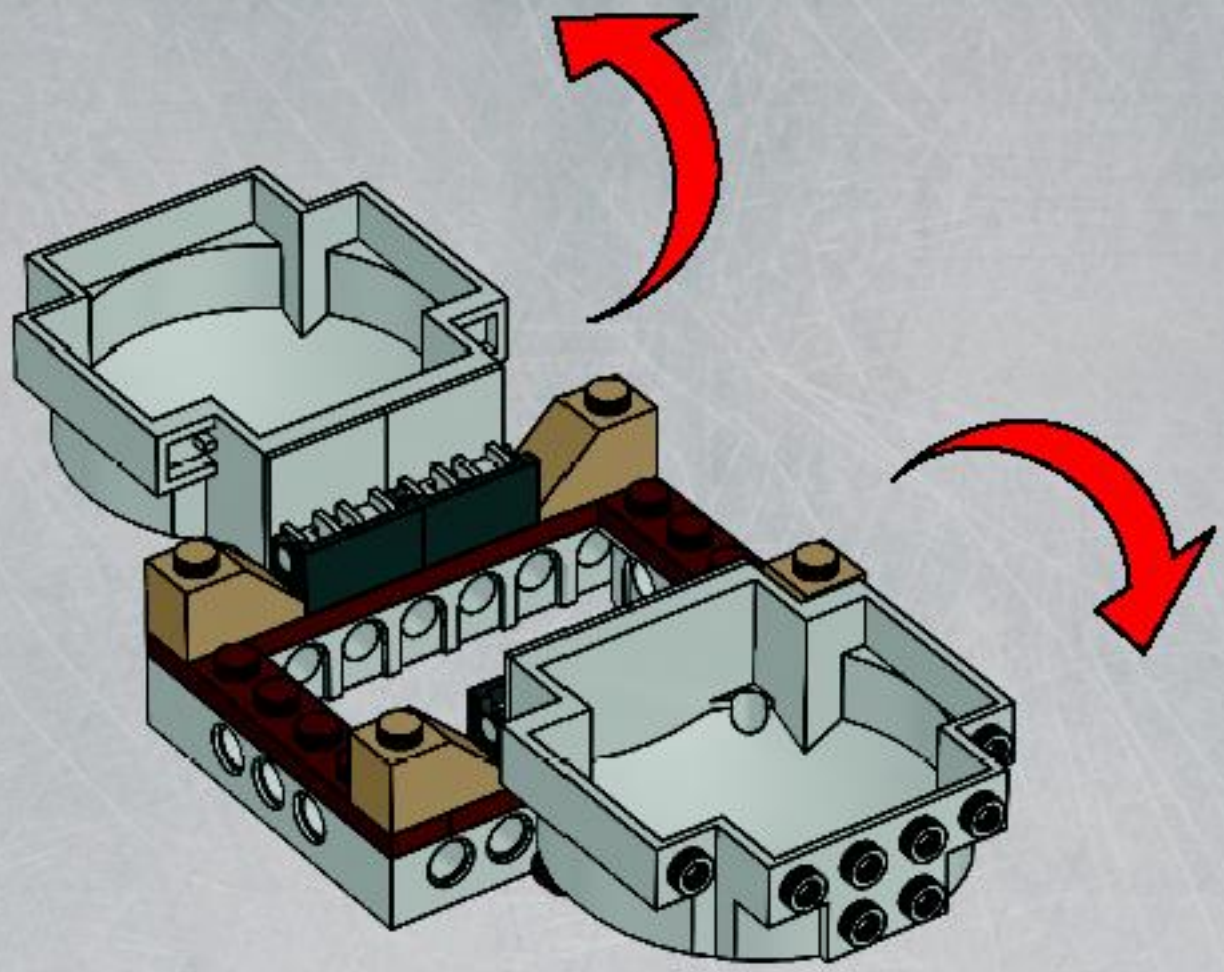

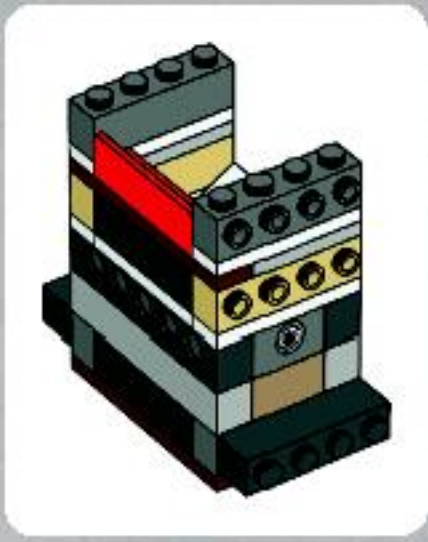

1

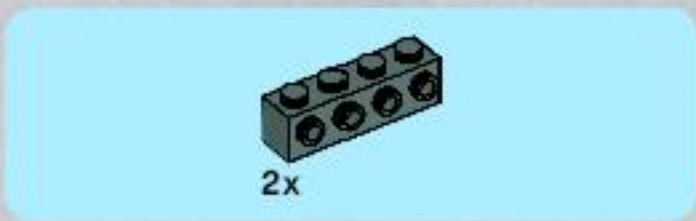
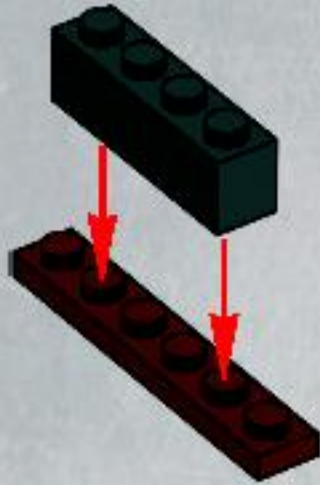

2

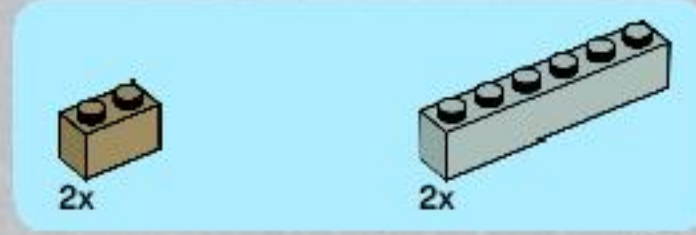
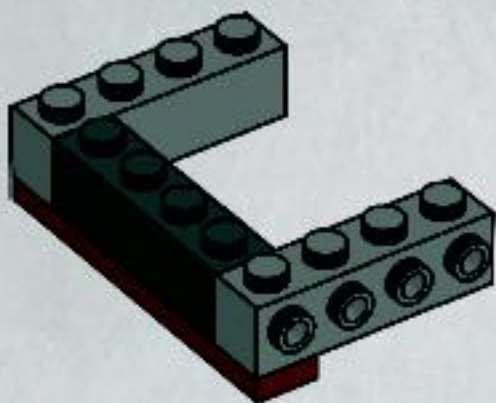

3

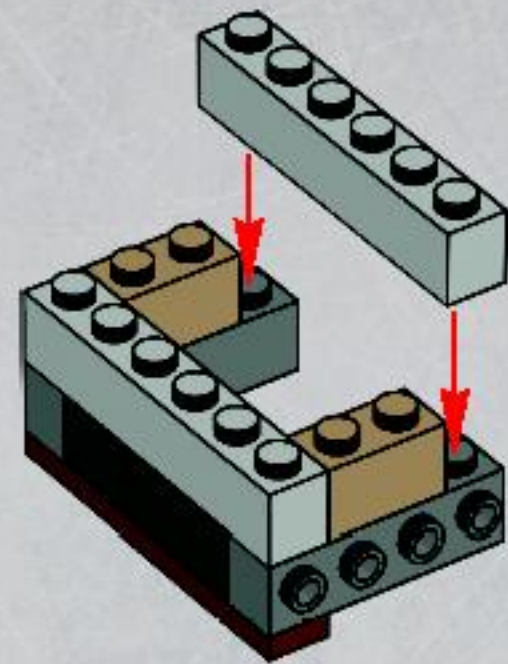

4

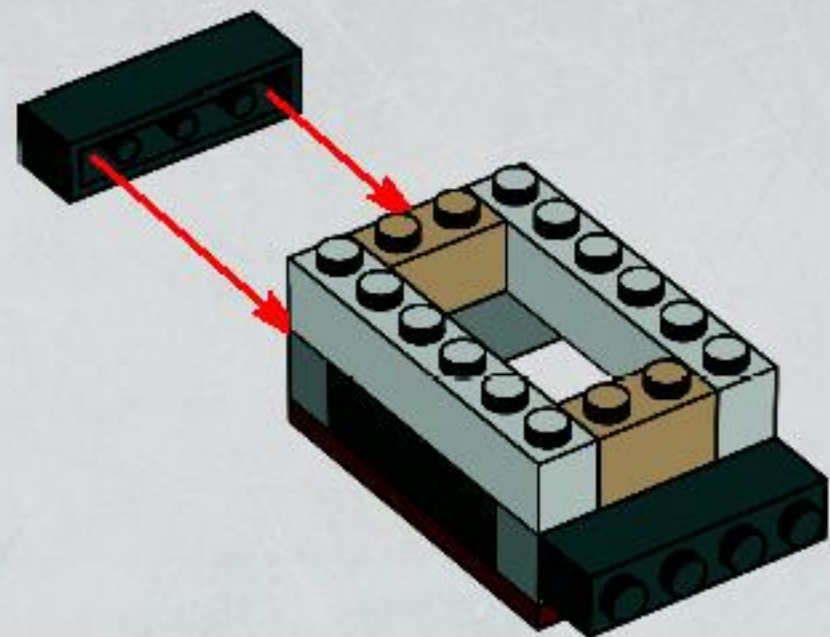

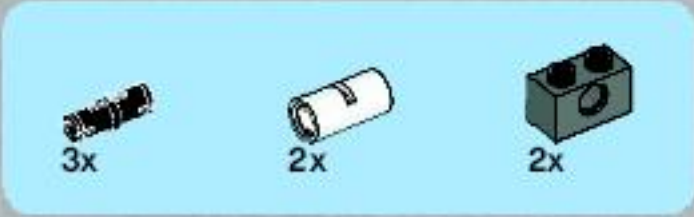

5

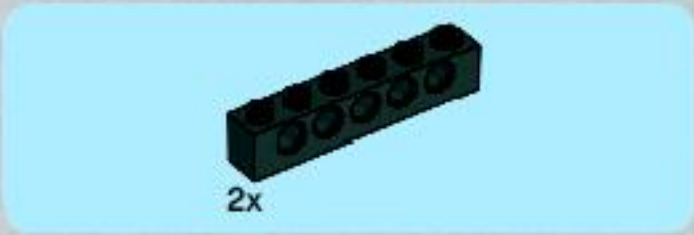
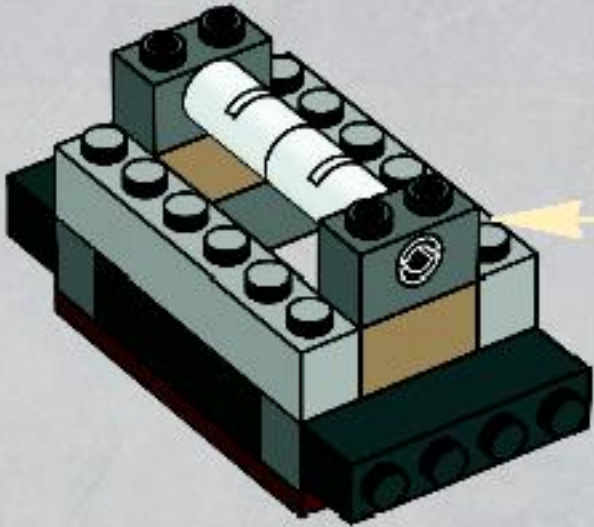
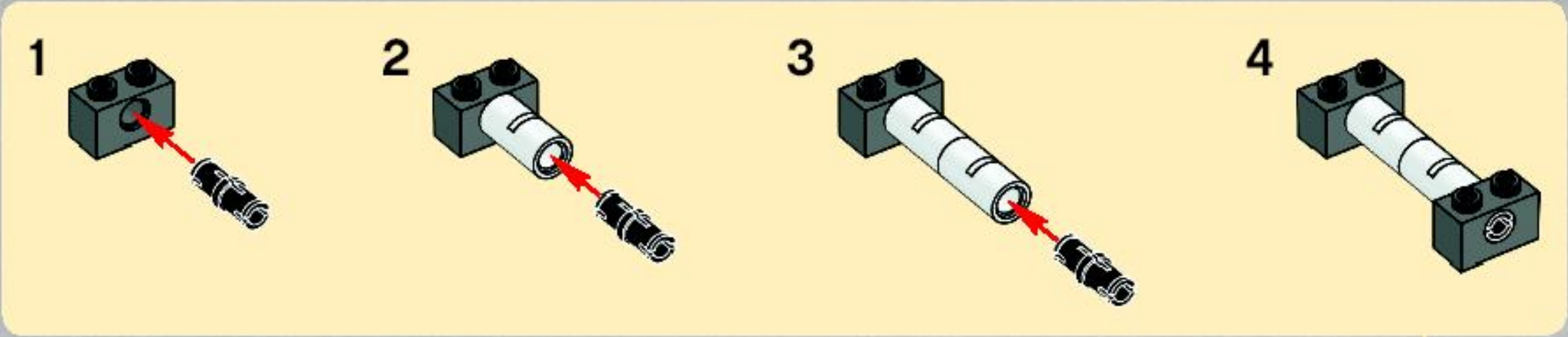

6

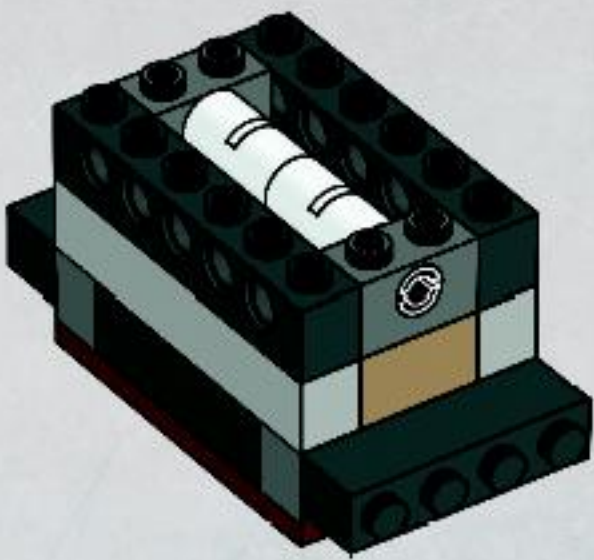



2x



3x

7

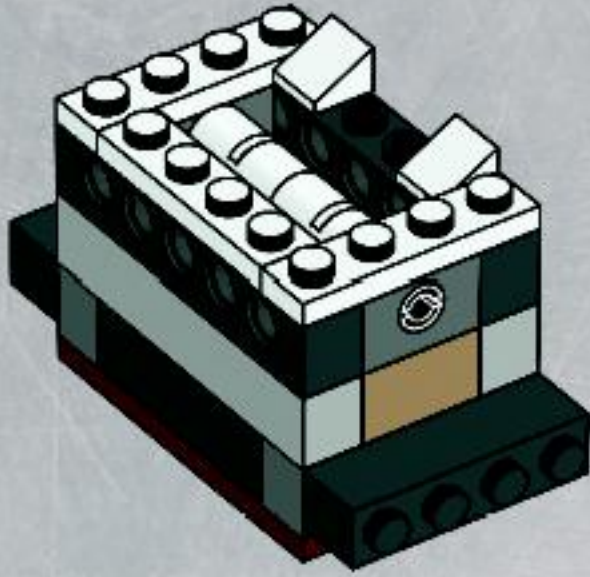

2x



1x

9



1x



2x

8

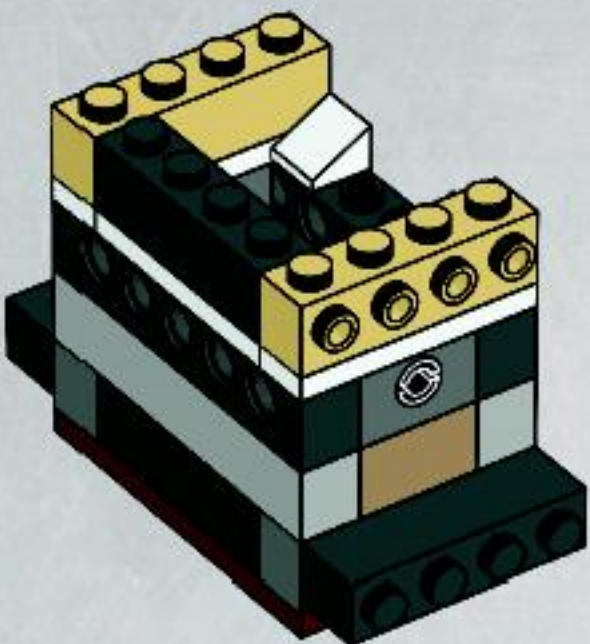

2x



1x

10





11

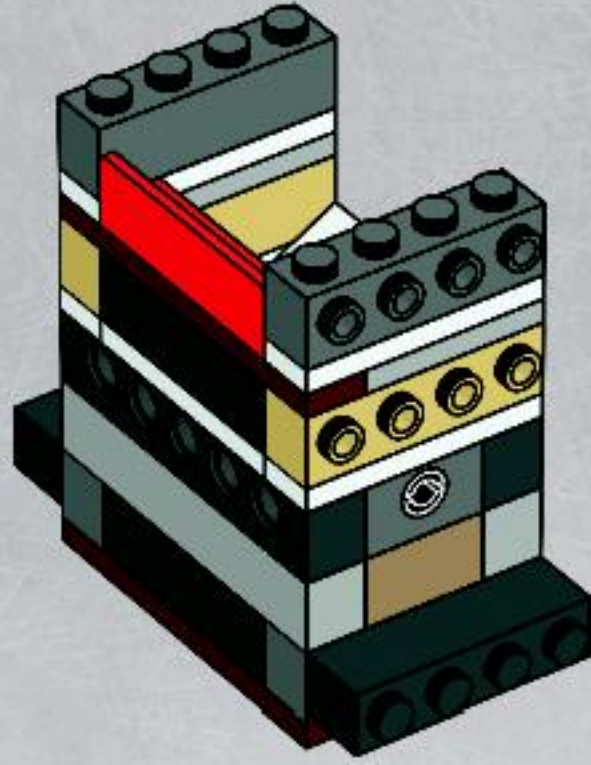

12

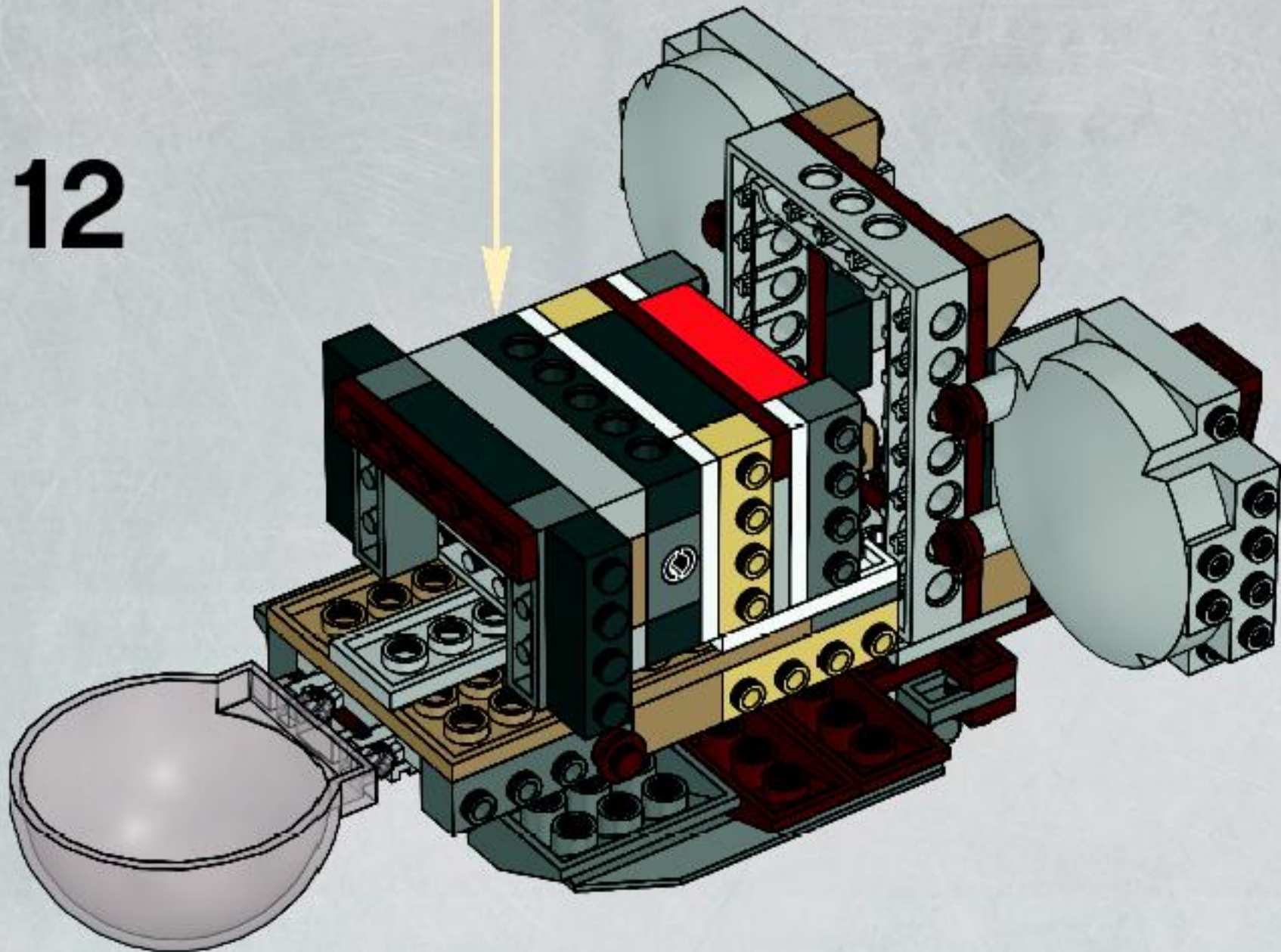

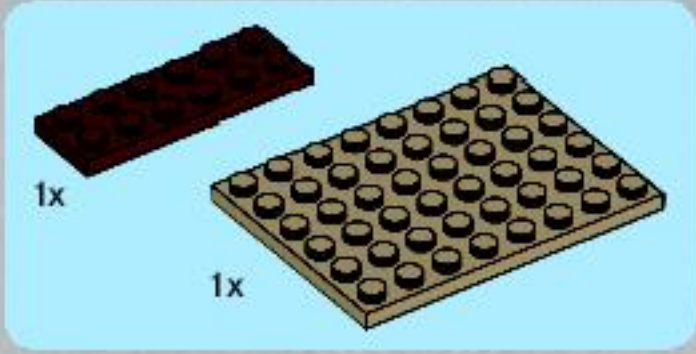
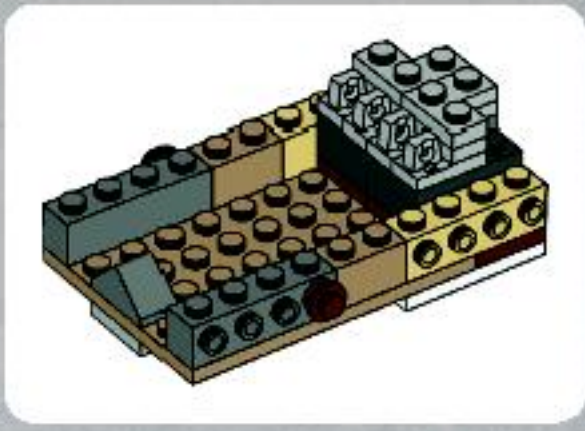

1

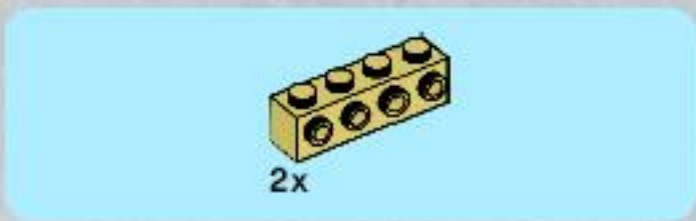
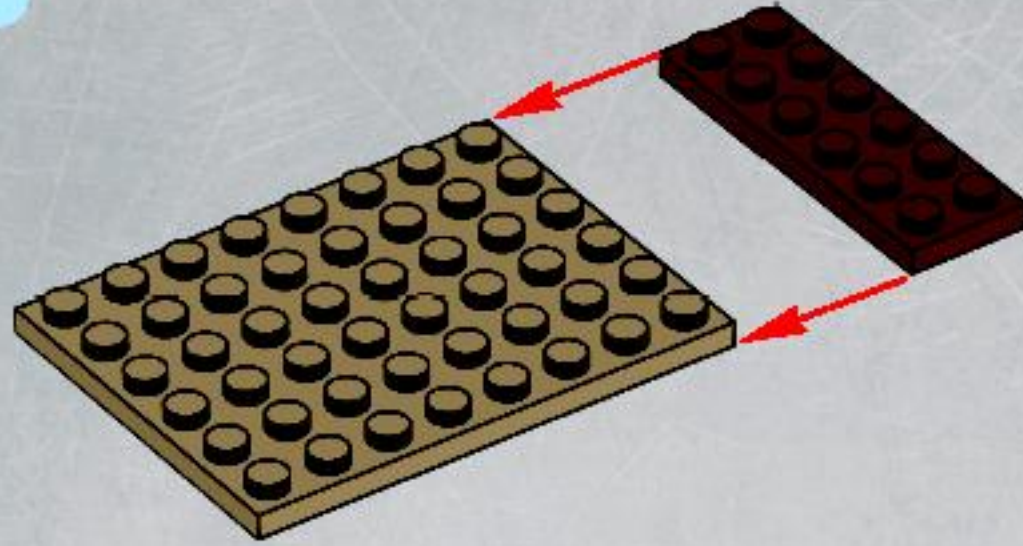

2

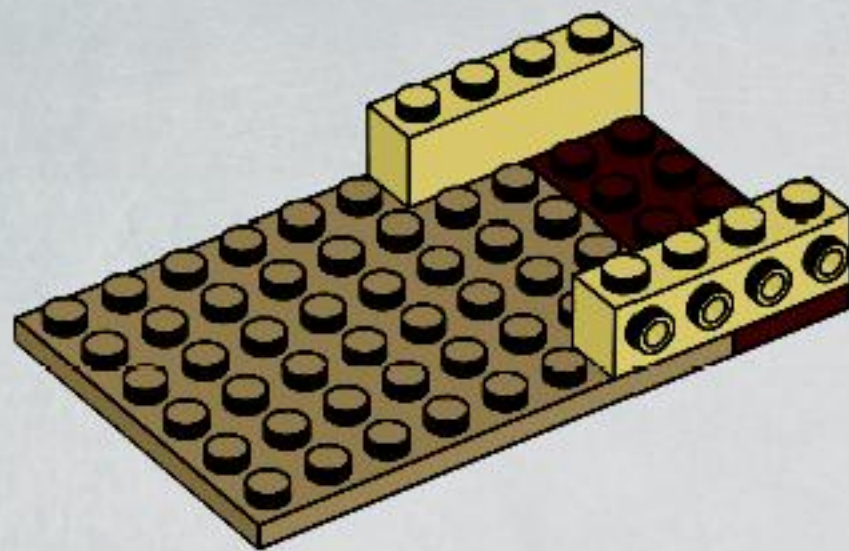



2x



2x

3

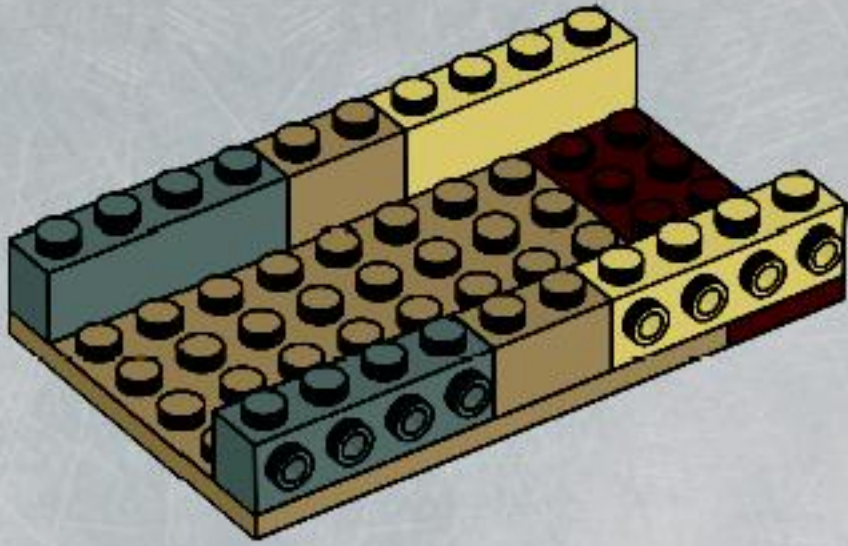

2x



2x

5

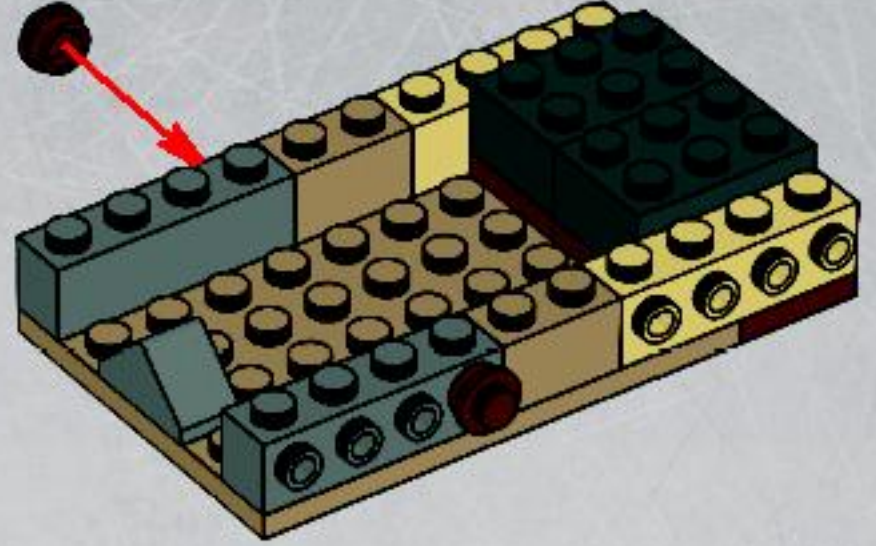

1x



2x

4

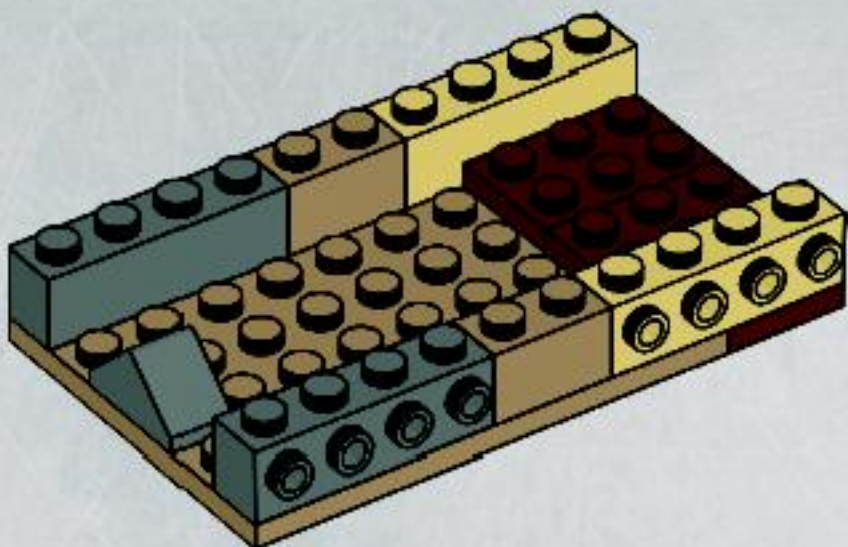

1x



4x

6

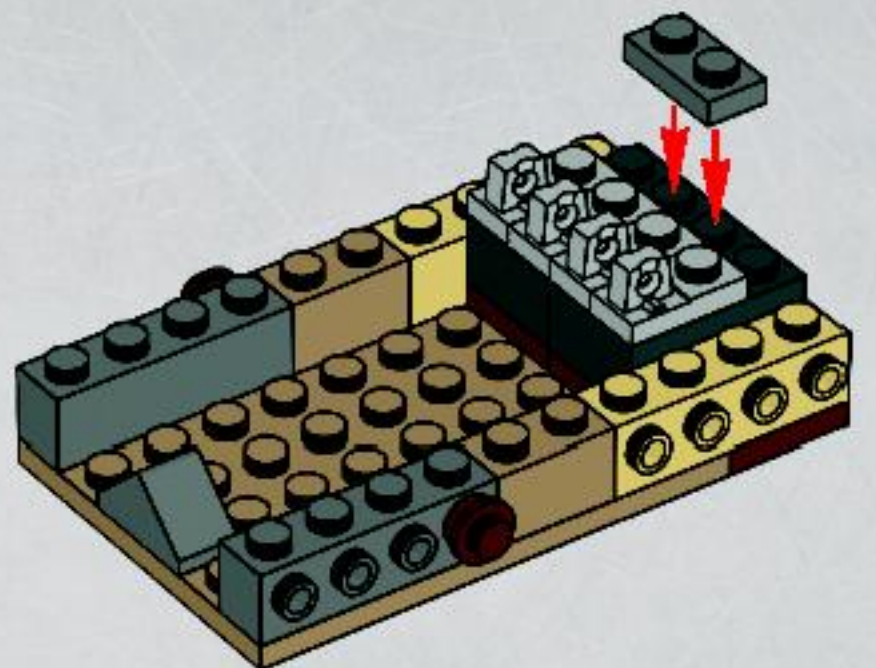

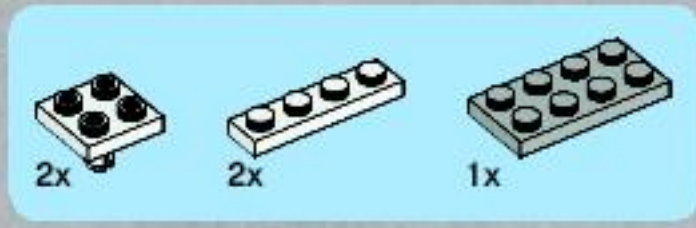

9

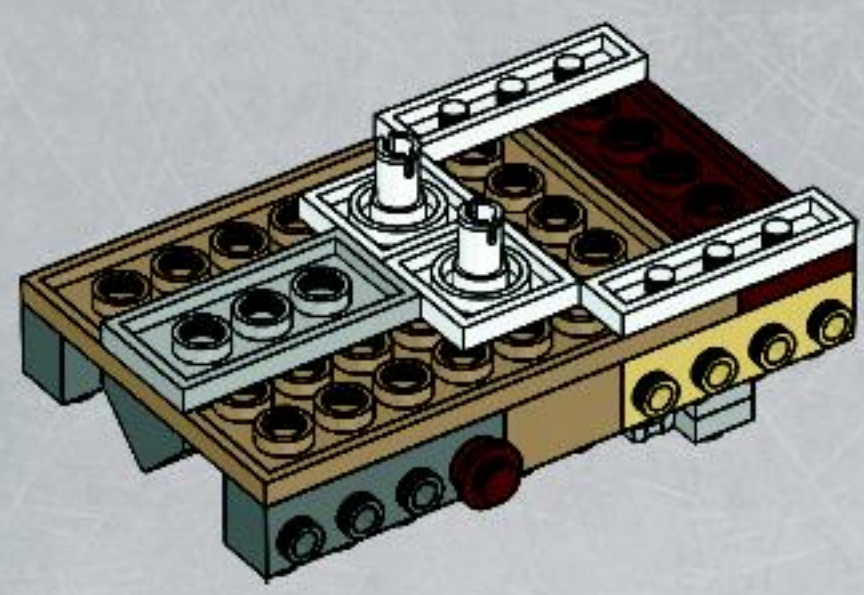

10

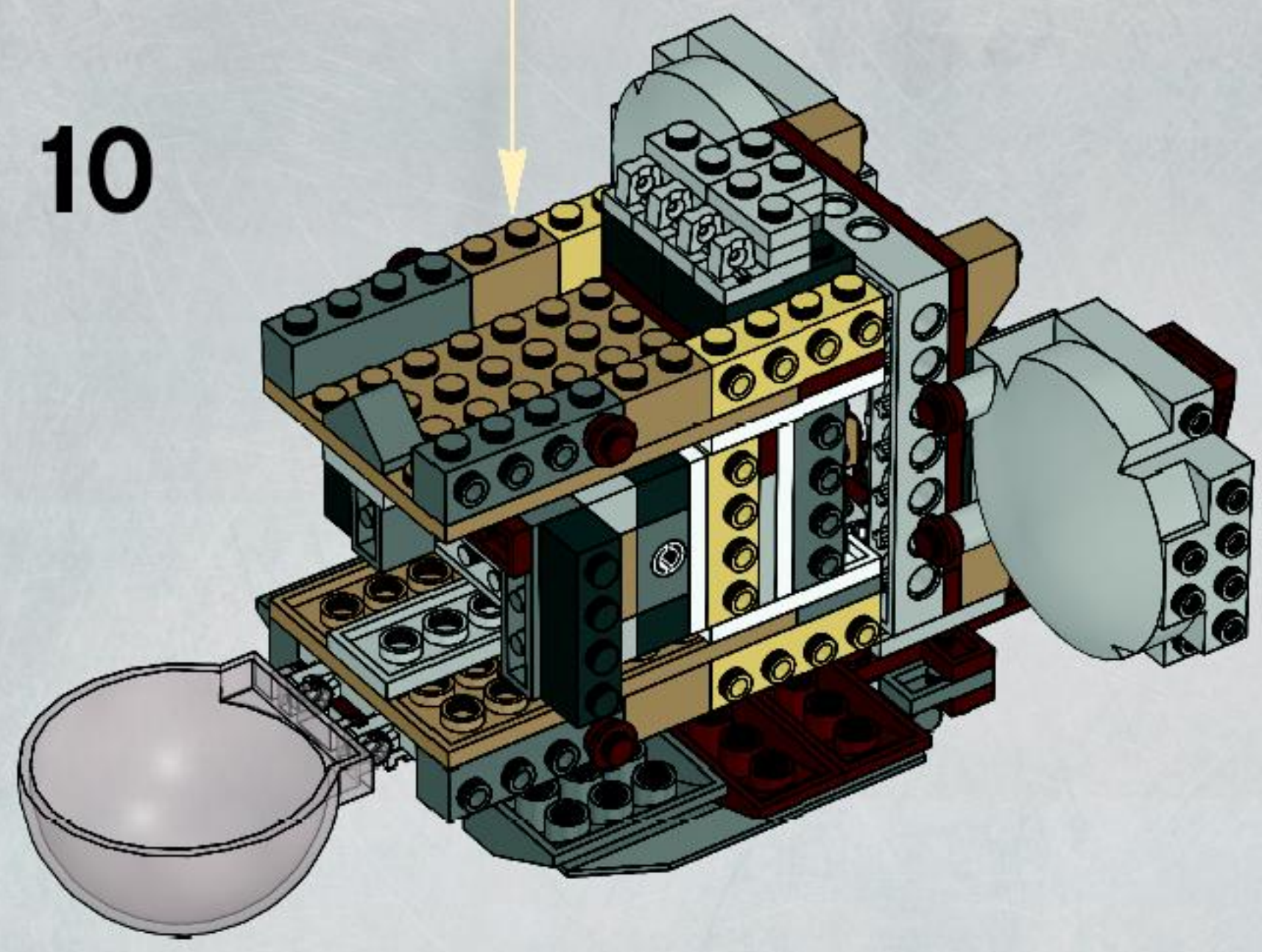

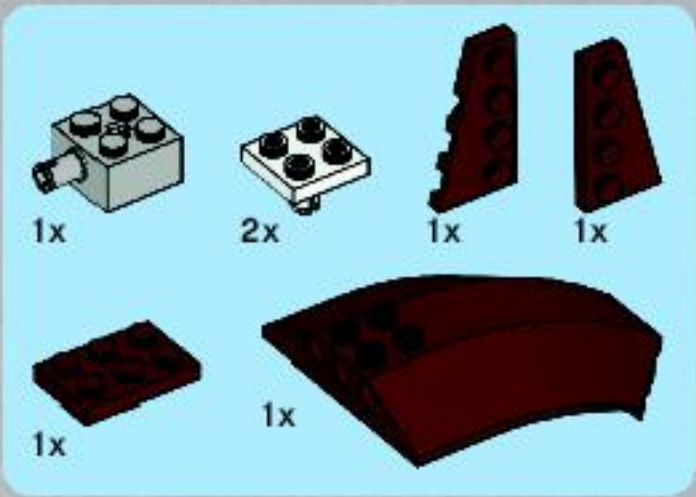

11

1

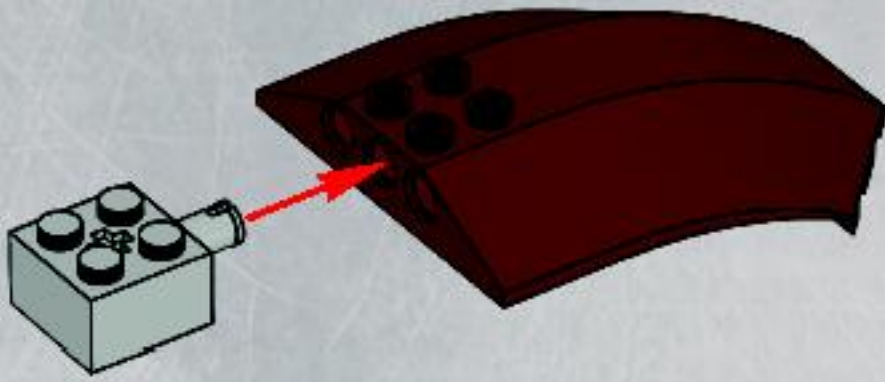

2

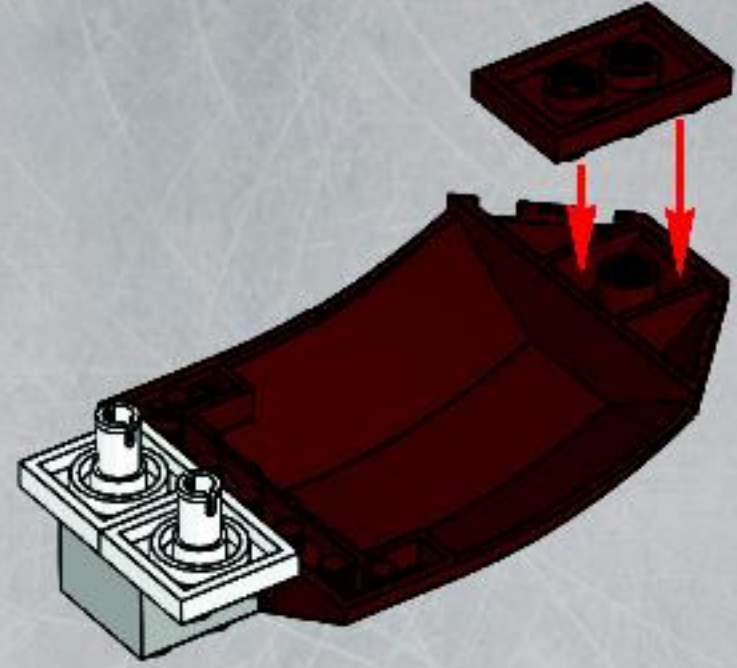

3

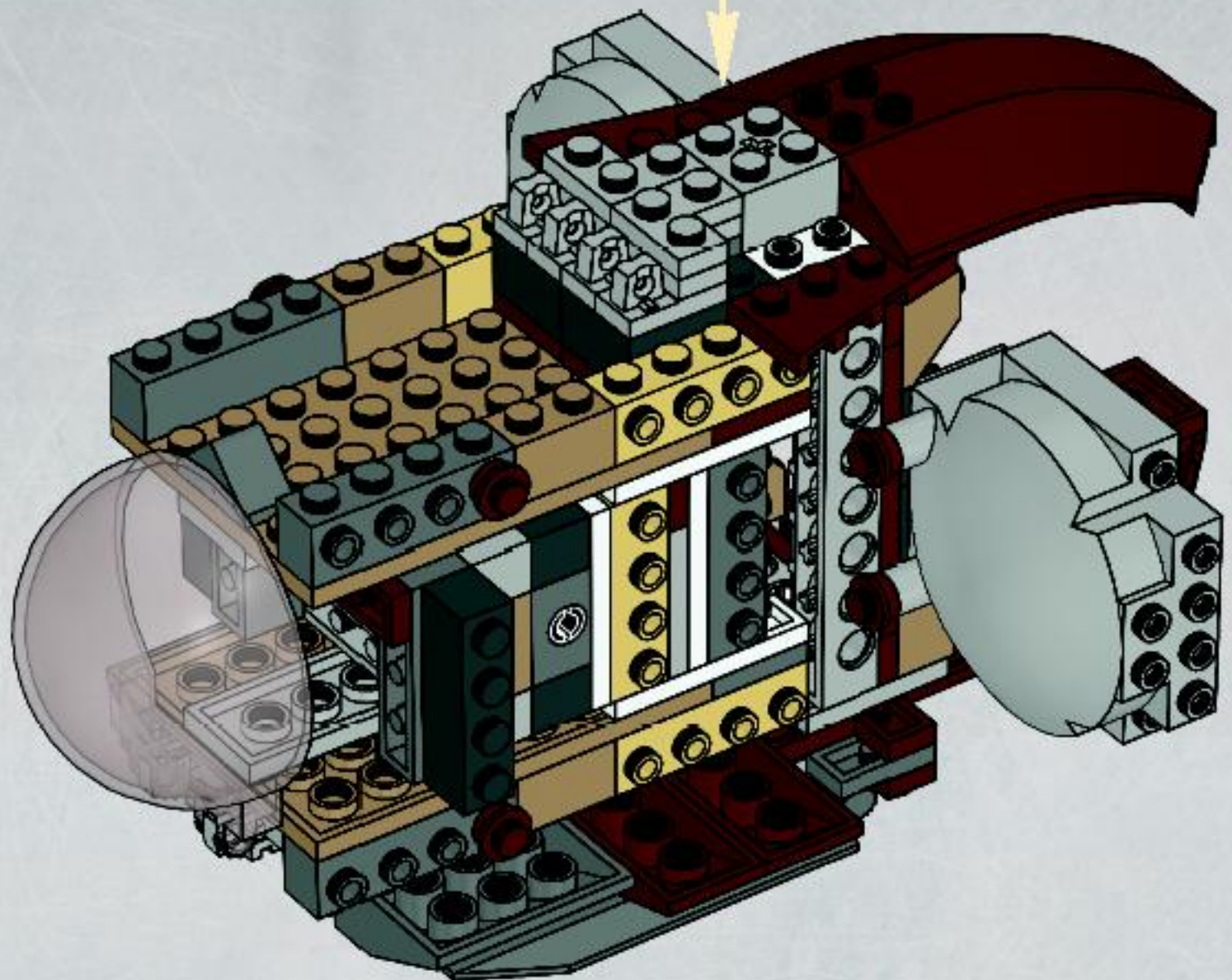
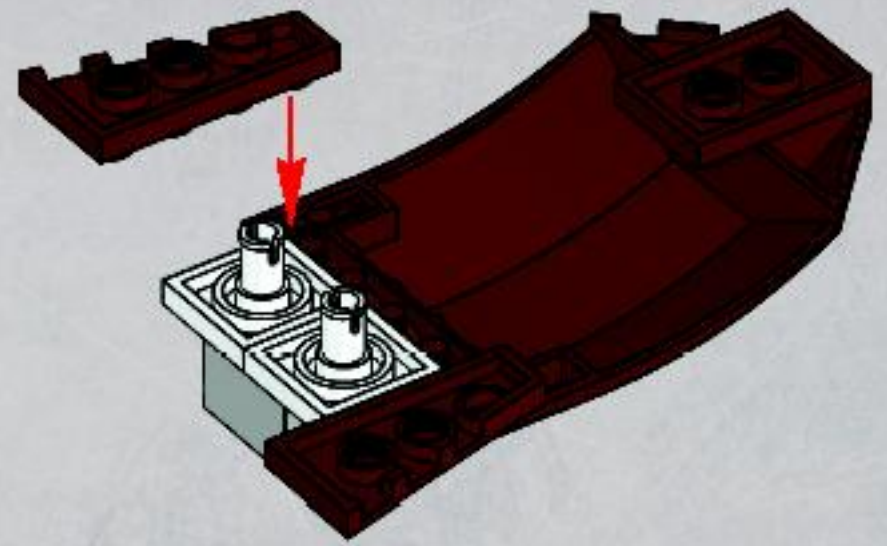



12

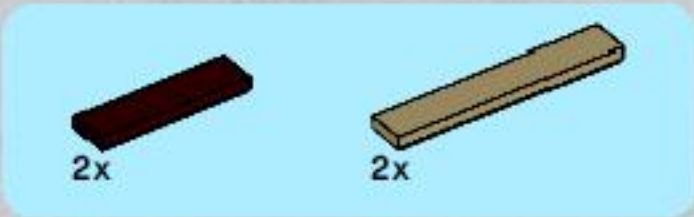
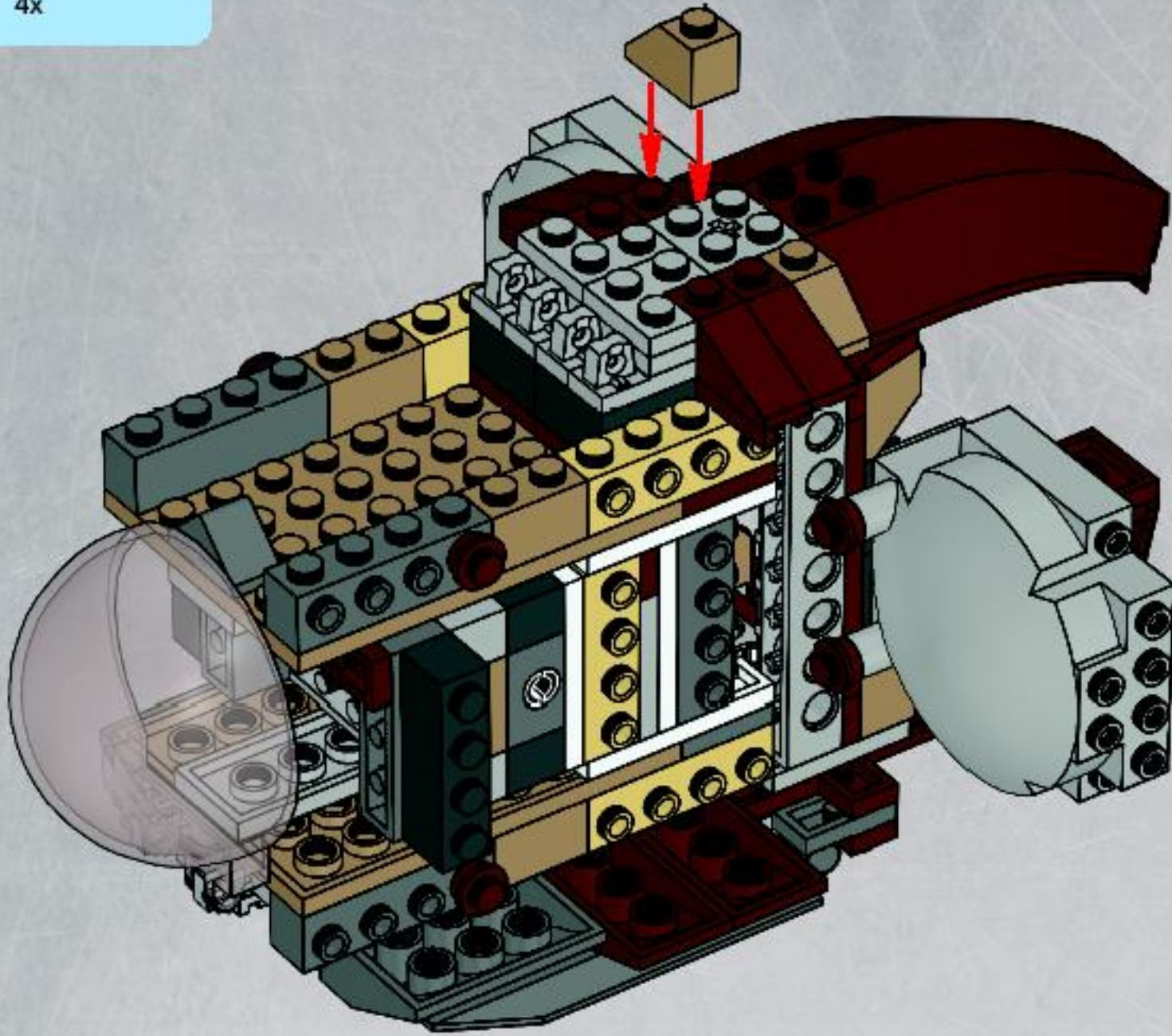

13

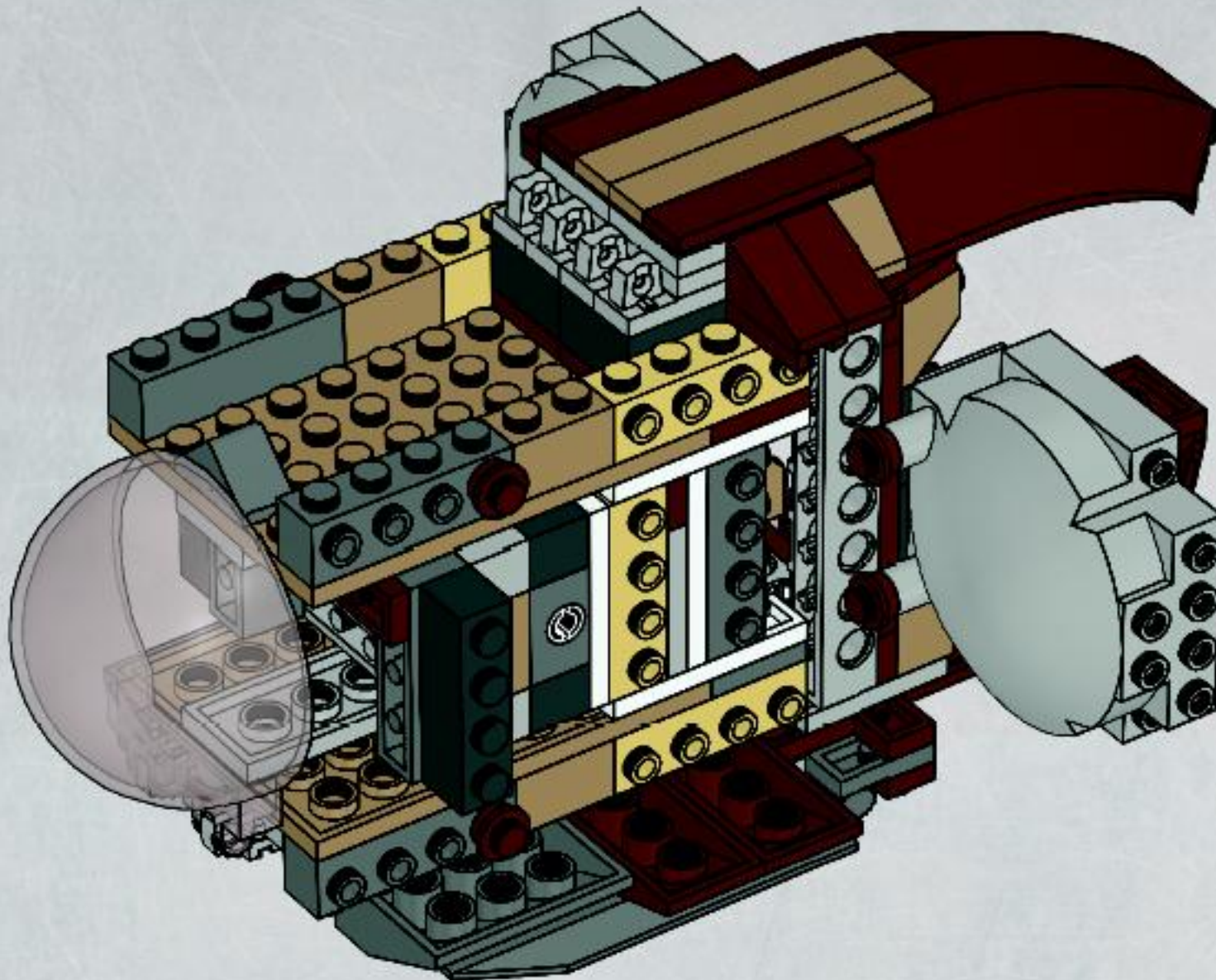

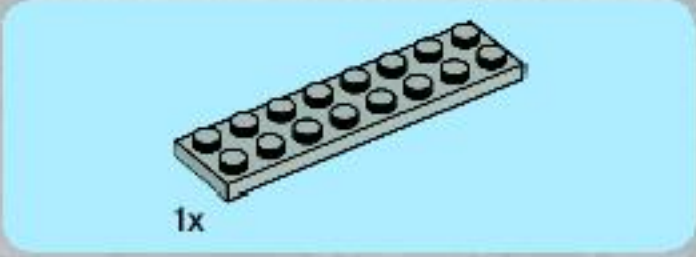
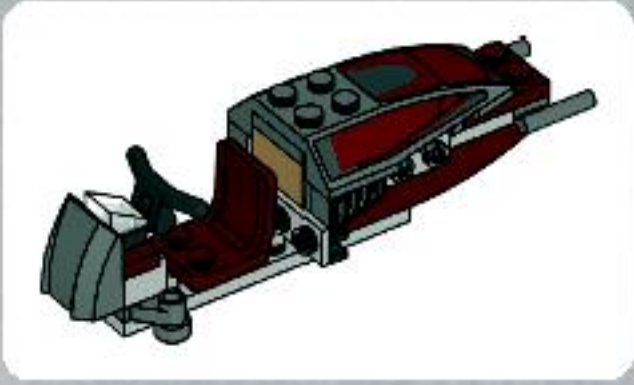

1

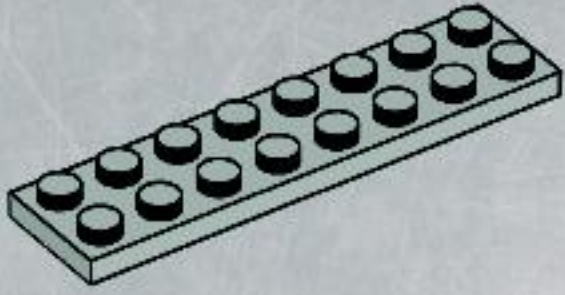

2

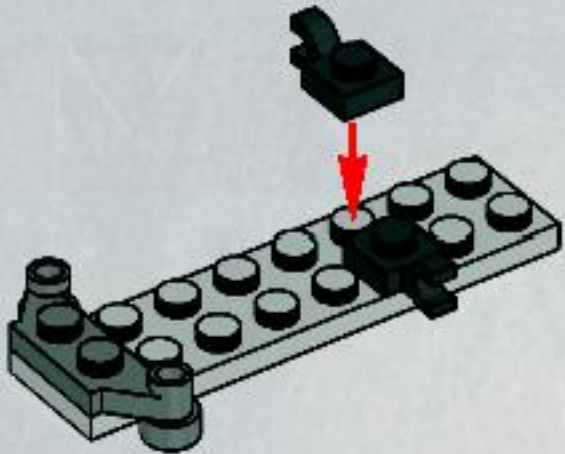

3

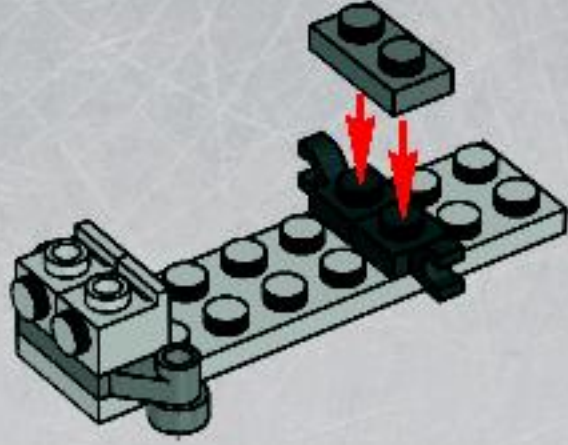

4

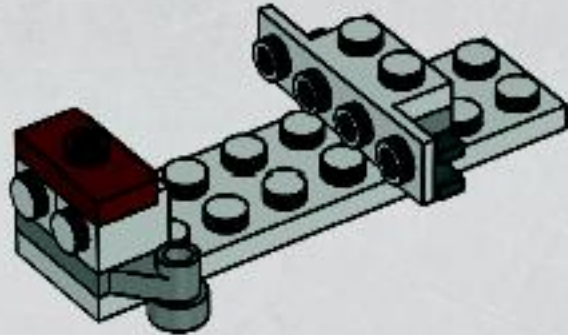

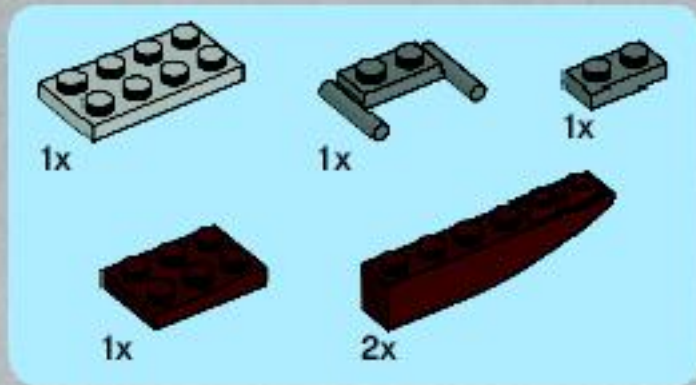

5

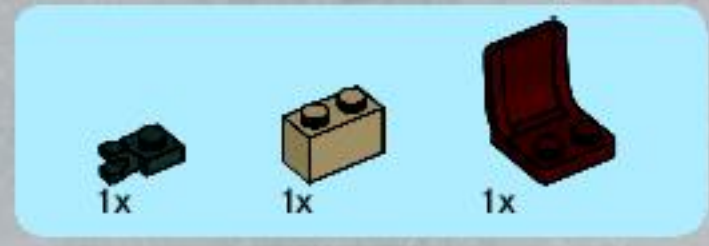
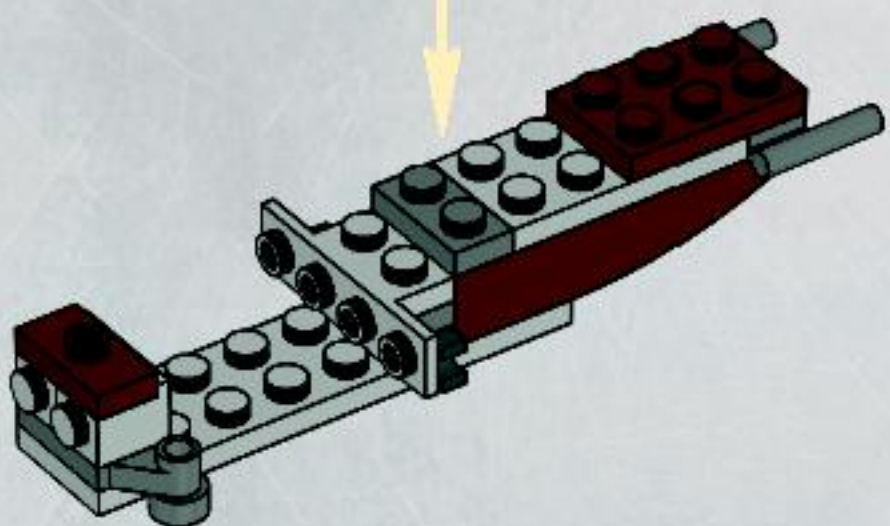
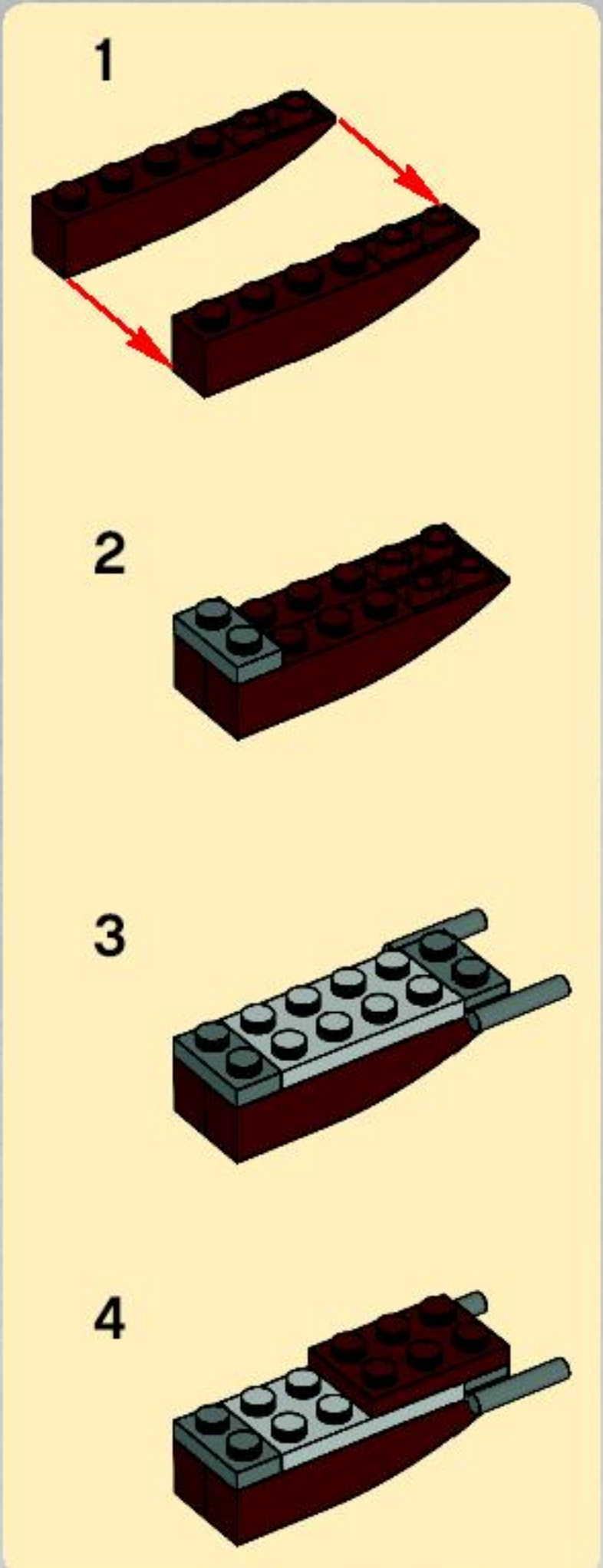

6

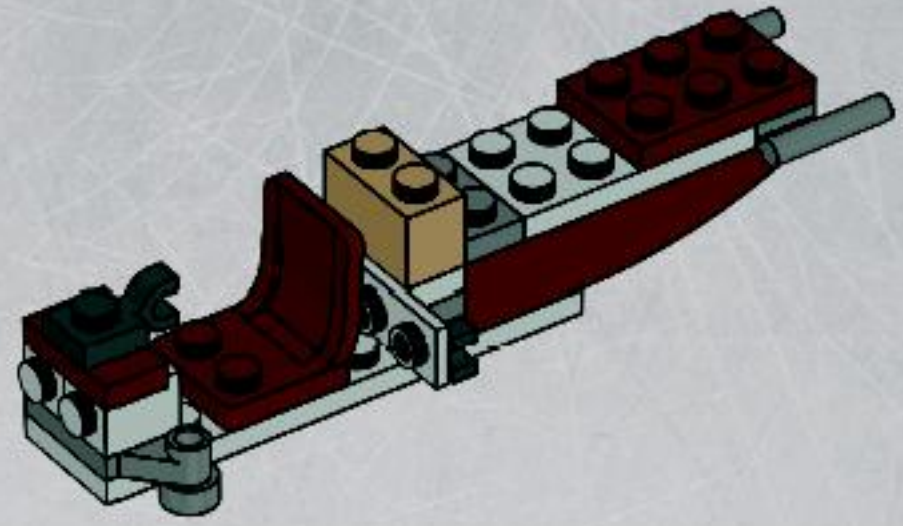

7

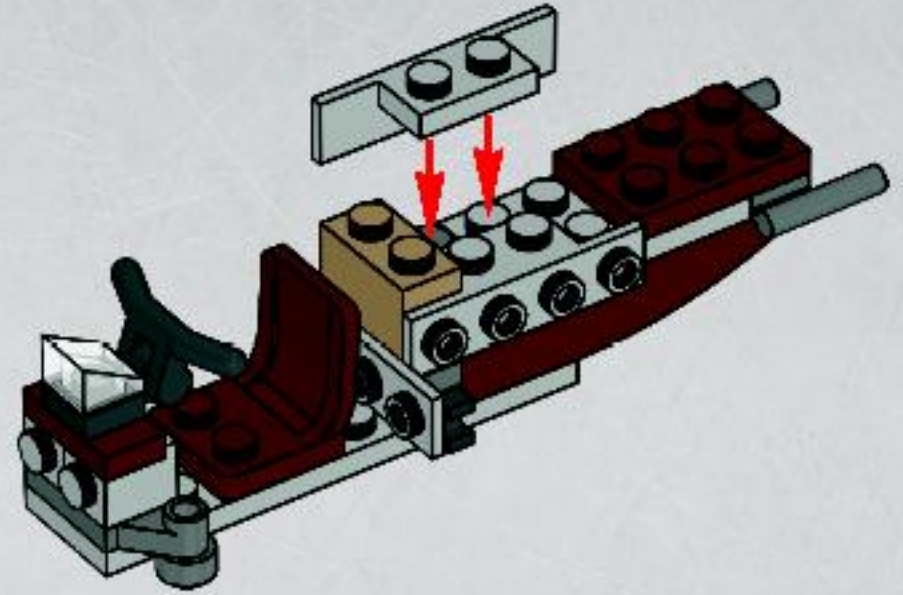



1x



2x

8

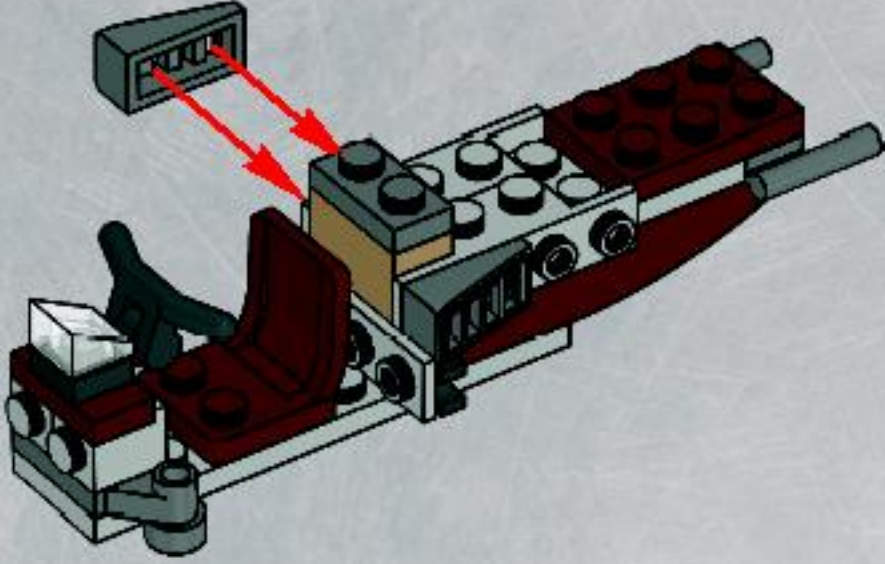

10

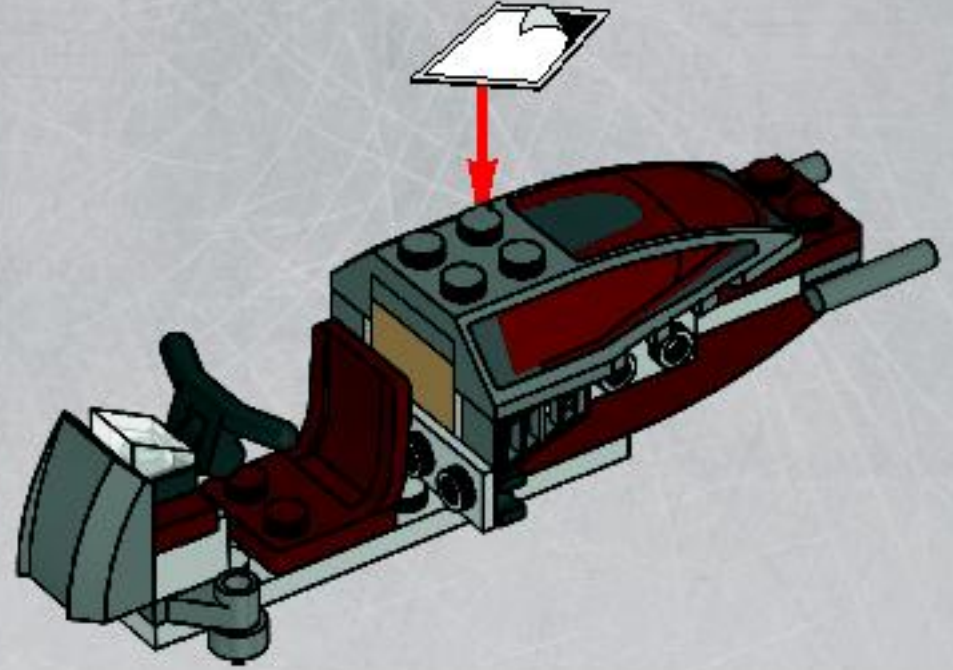

1x

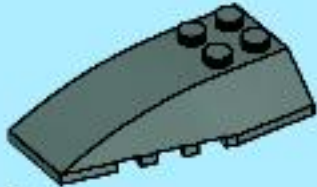

1x

9

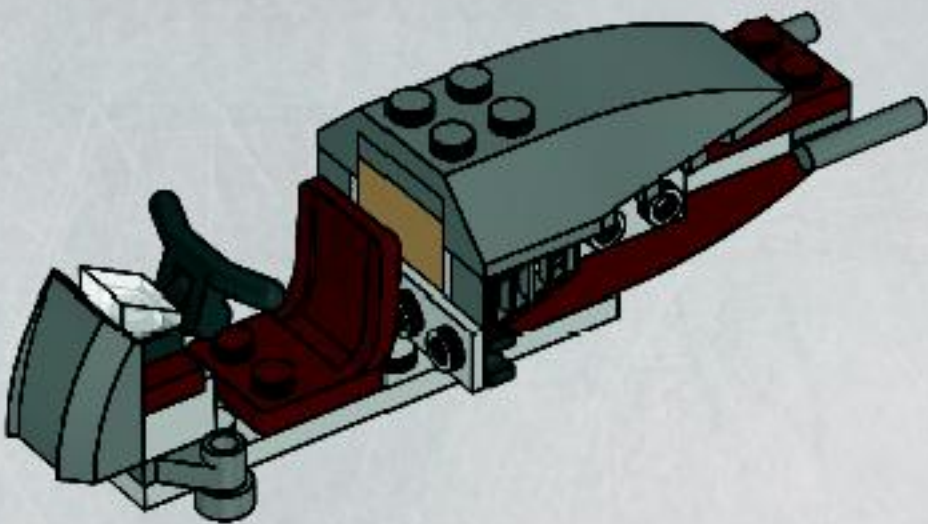

11





12

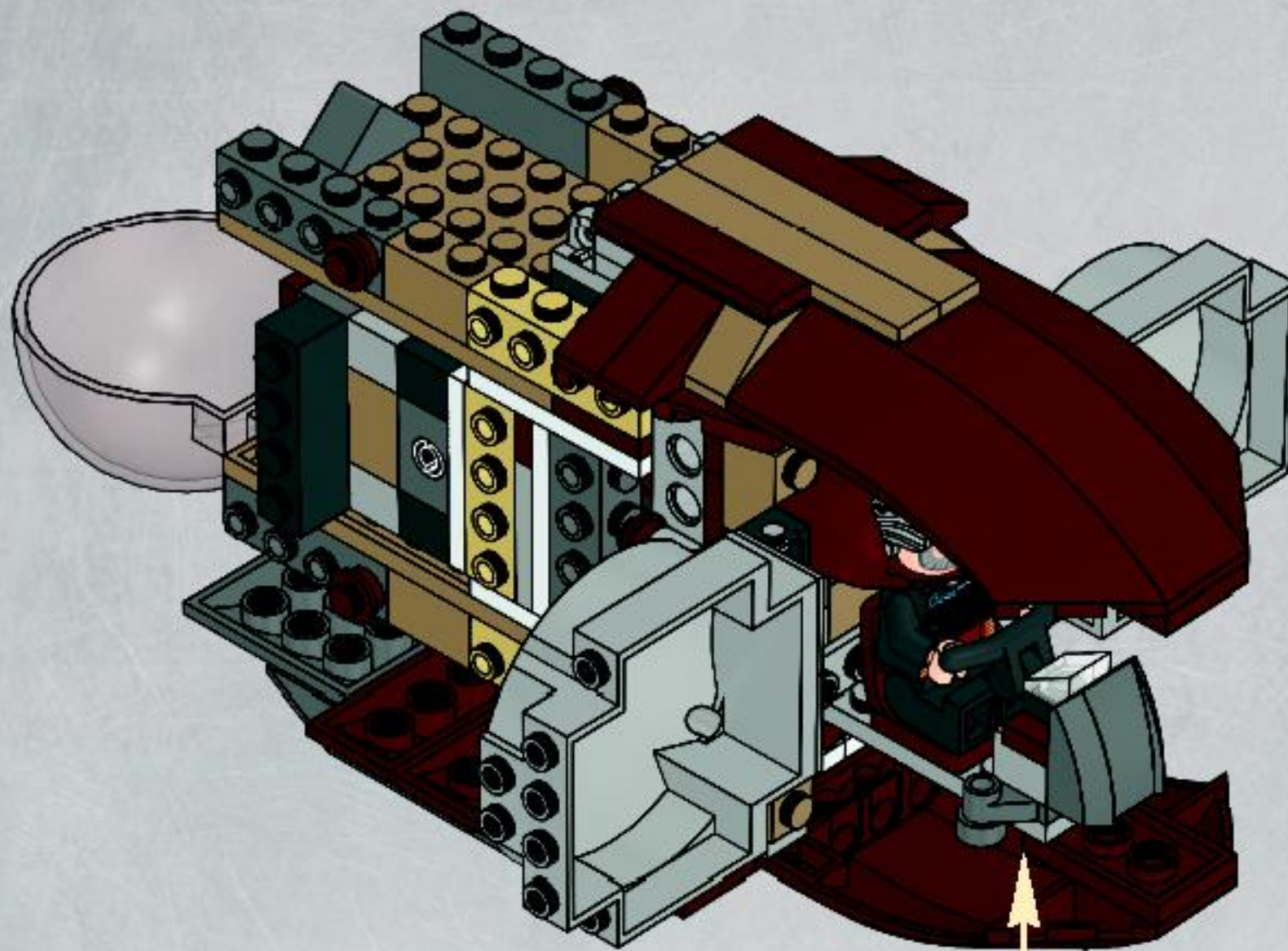

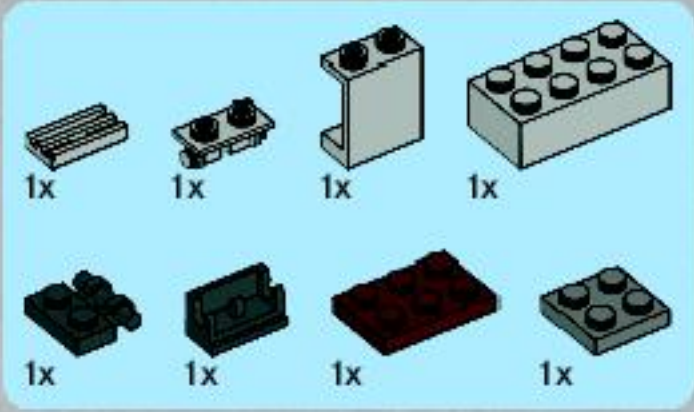

13

1

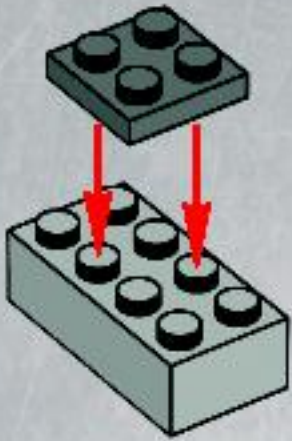

2

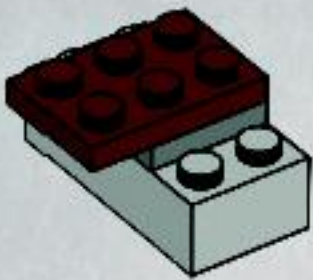

1

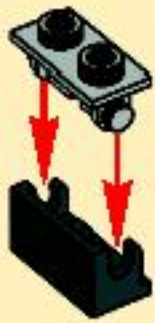

2

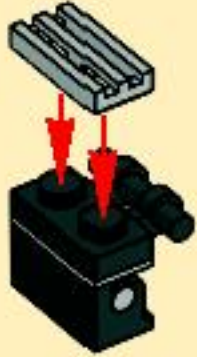

3

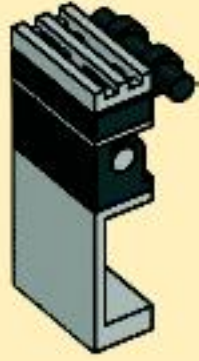

3



4

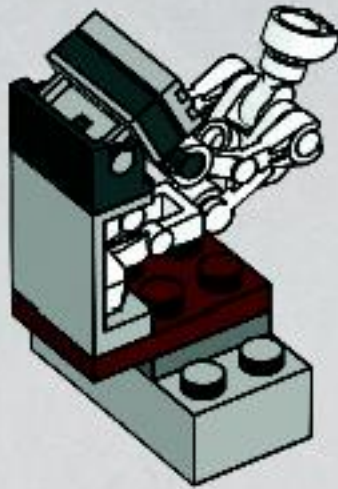

5

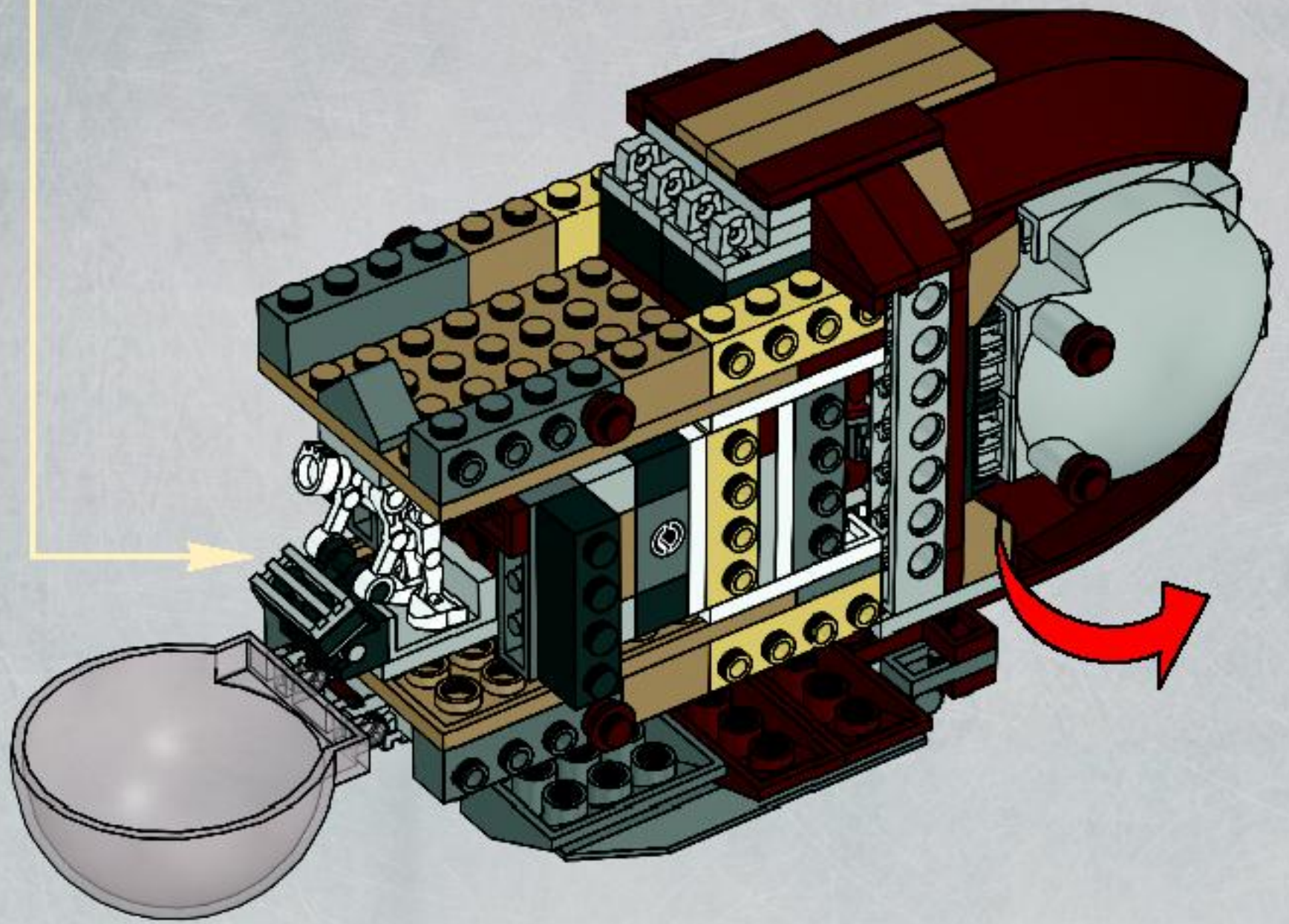
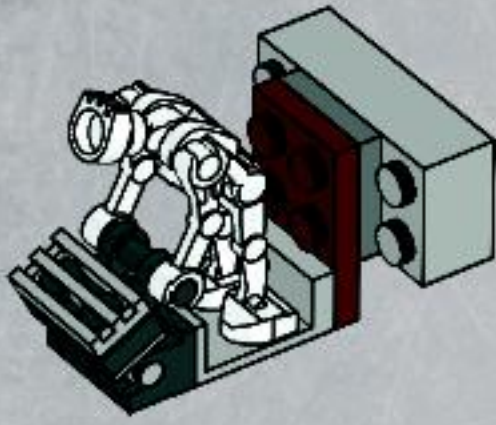

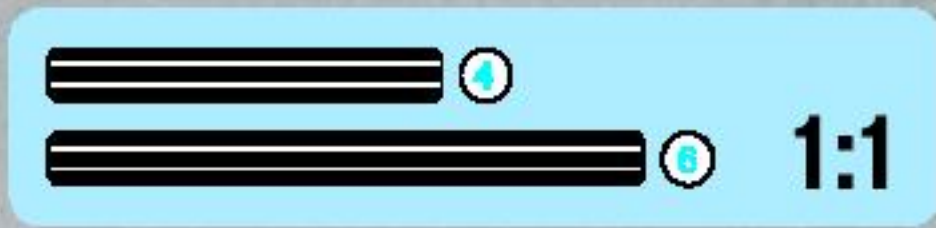
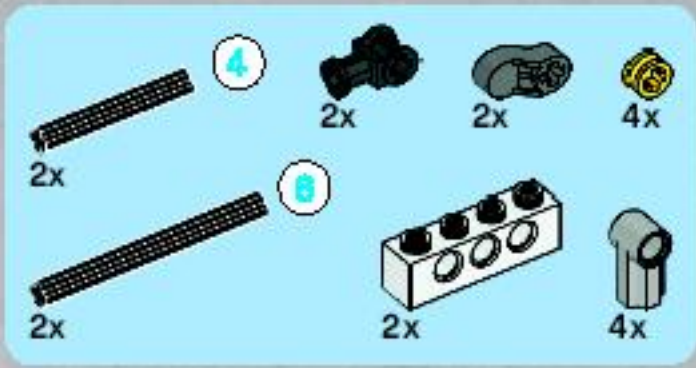

14

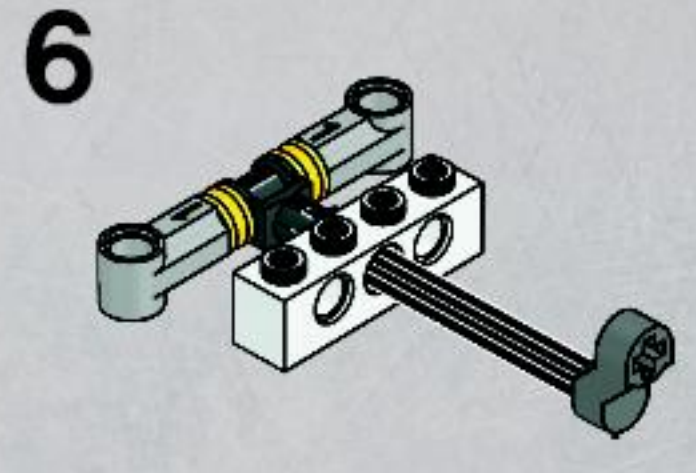
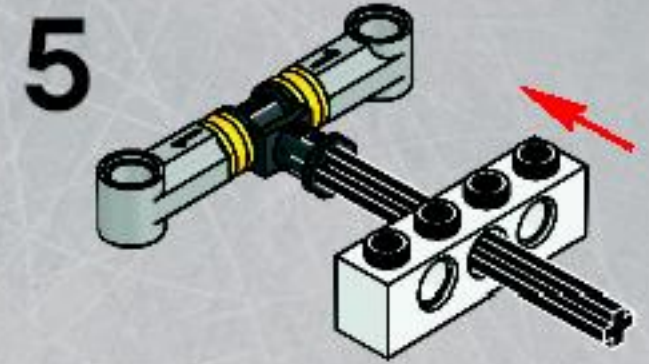
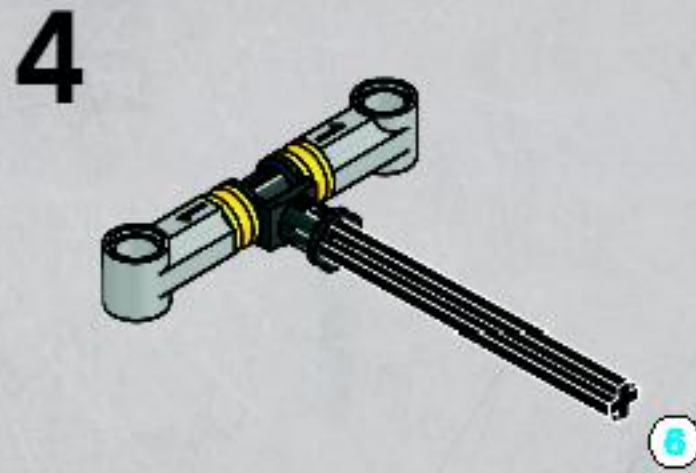
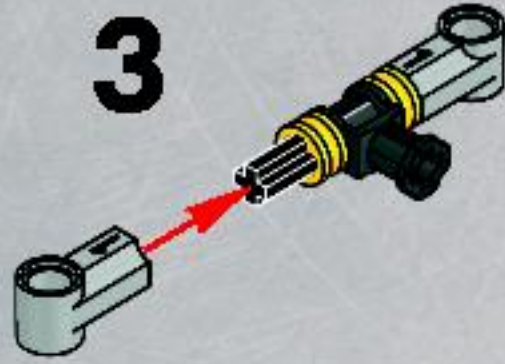
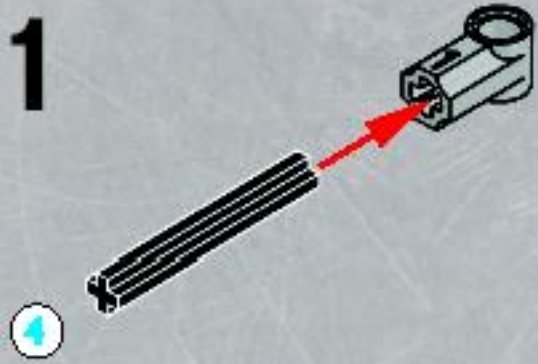

2x

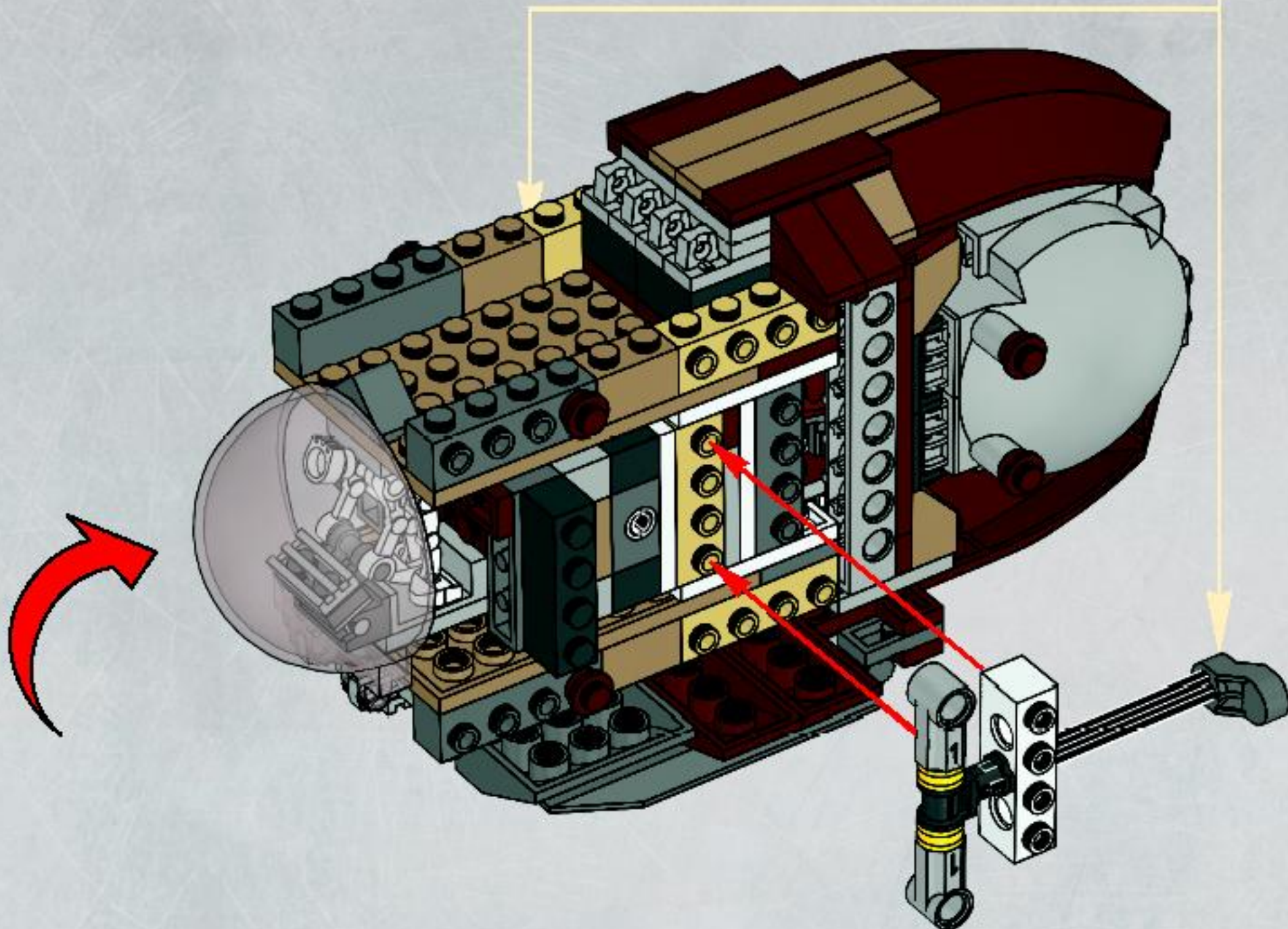

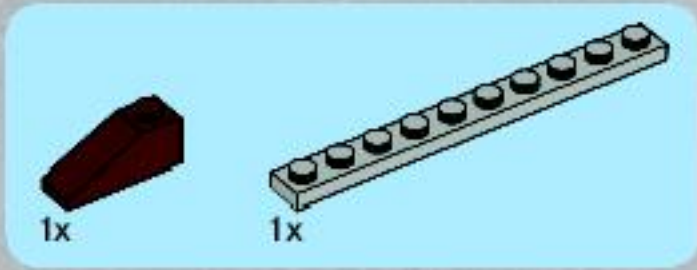
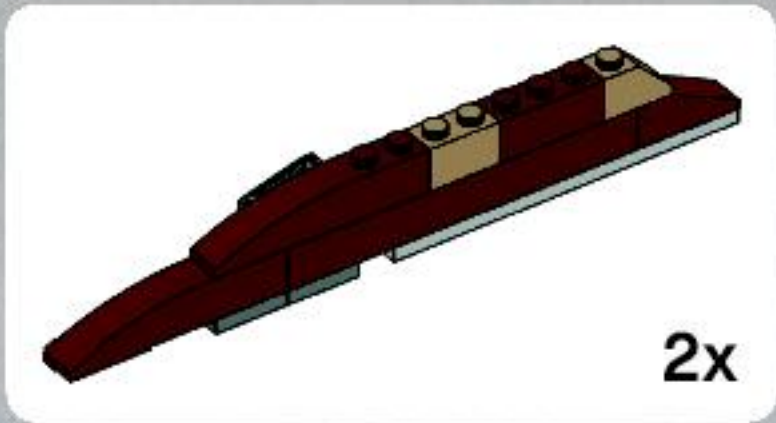

1

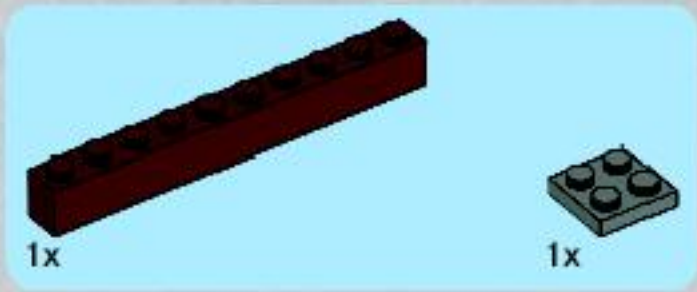
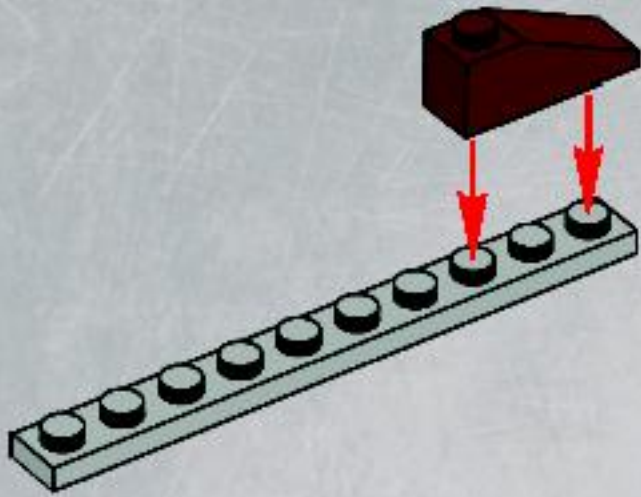

2

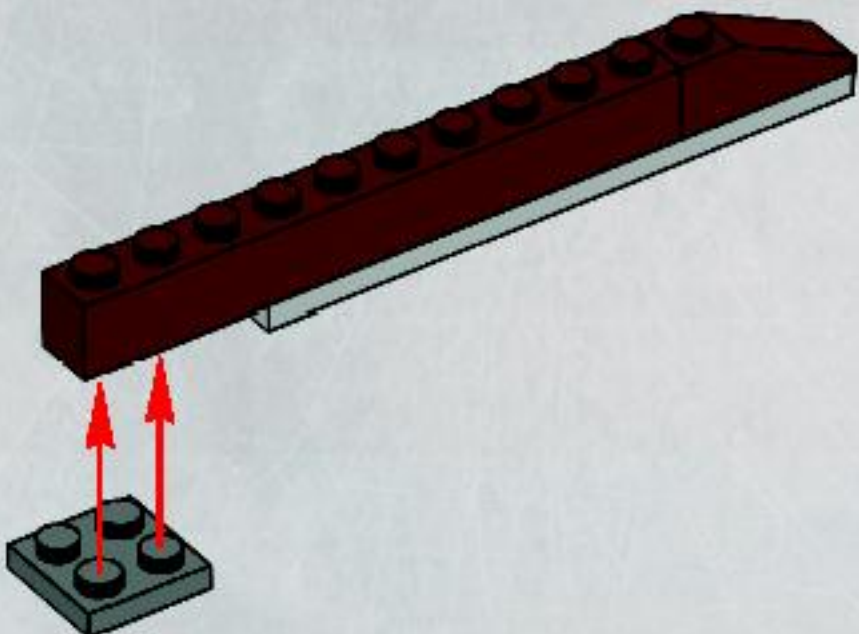

3

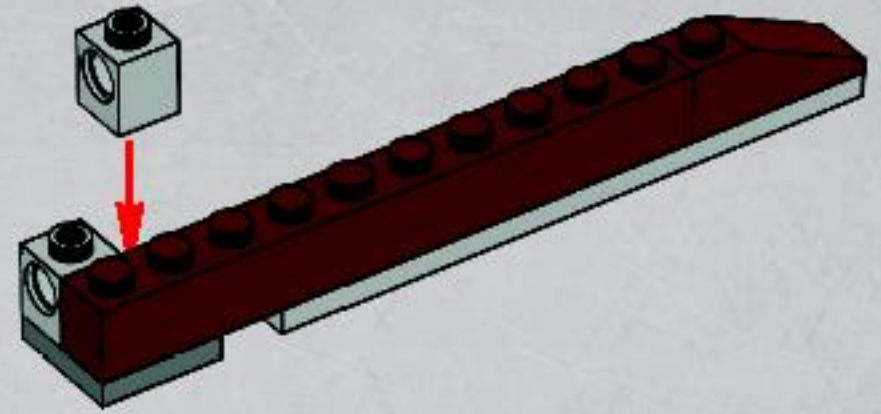

4

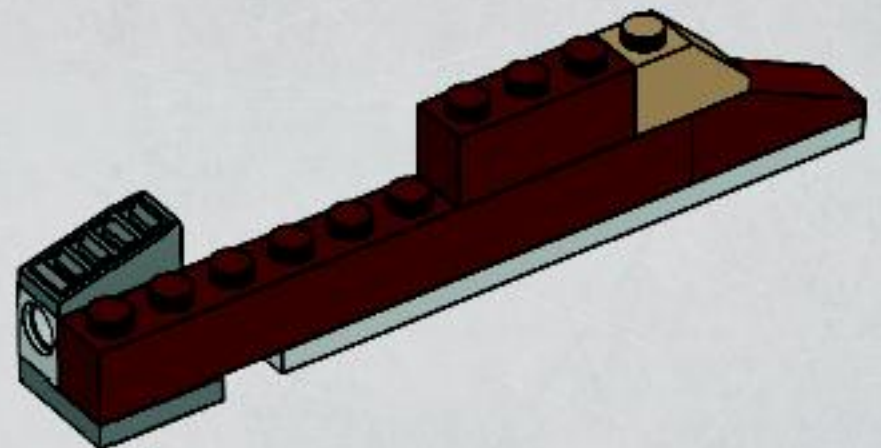

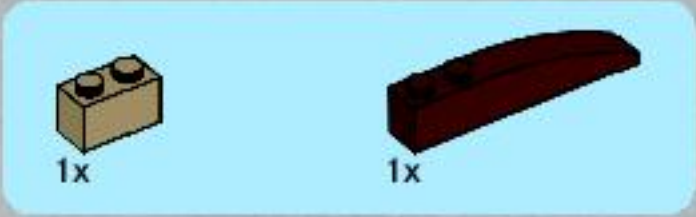

5

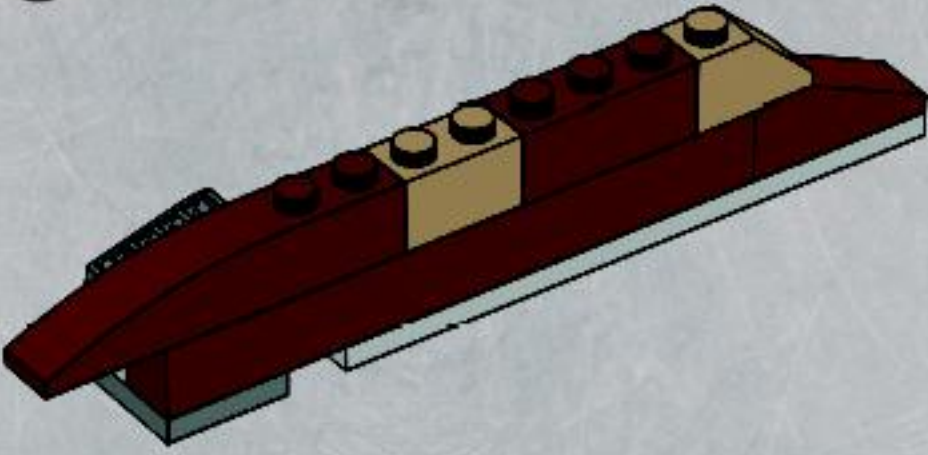

6

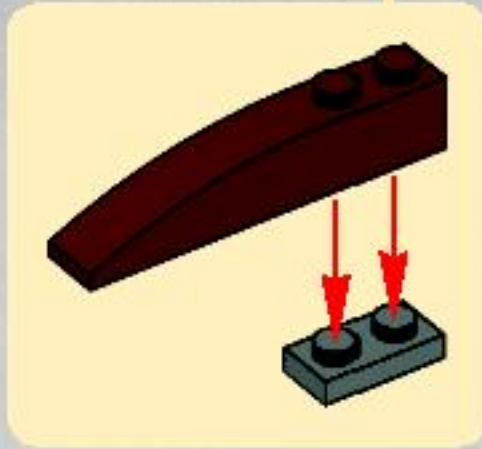
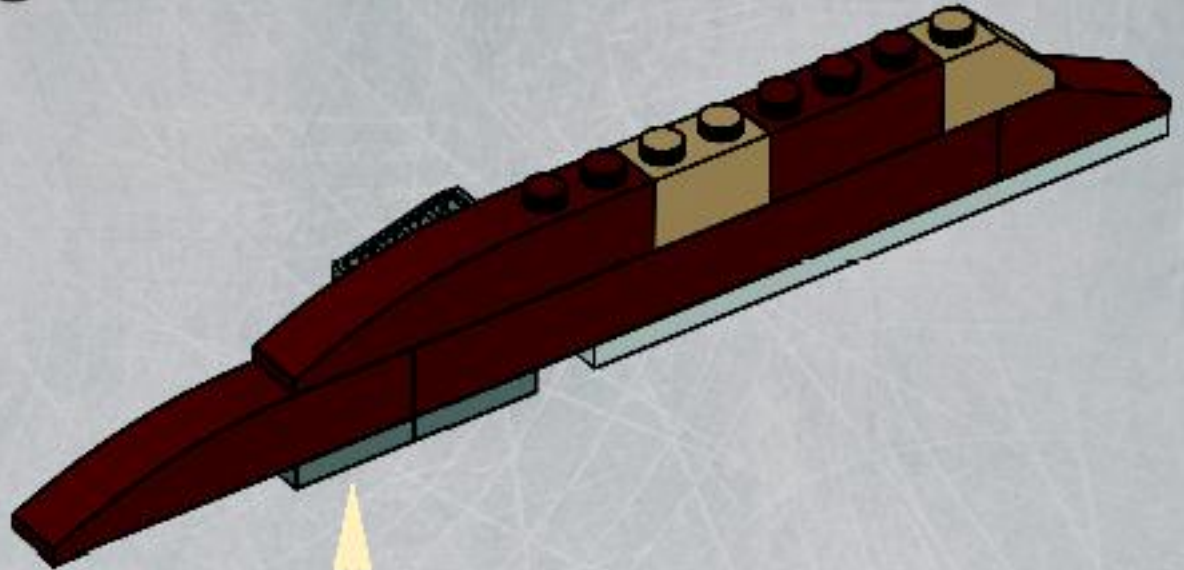

2x

15

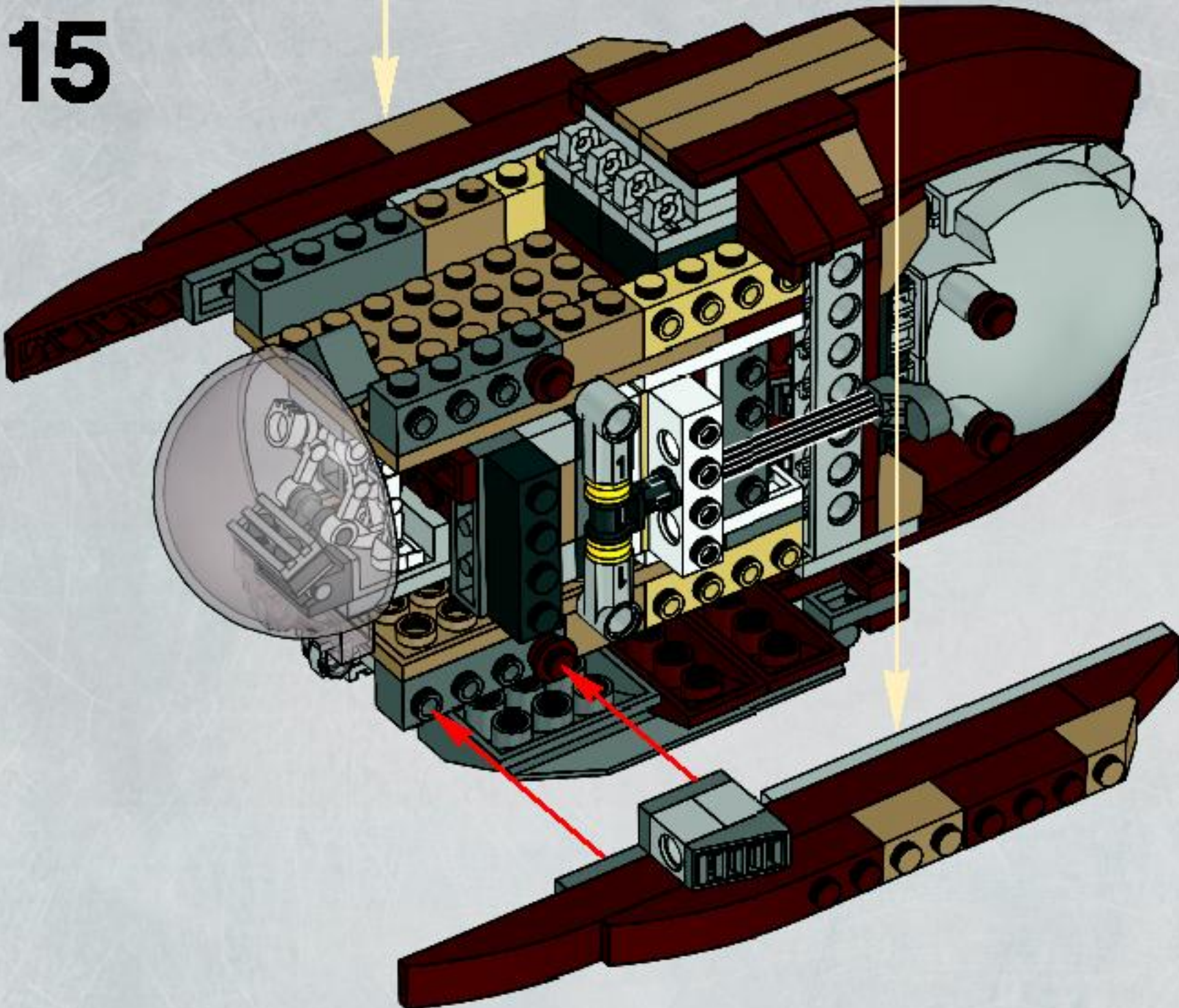

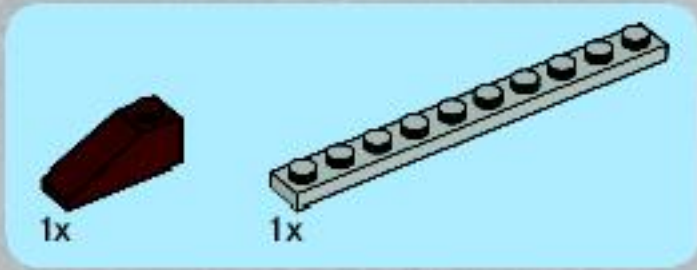
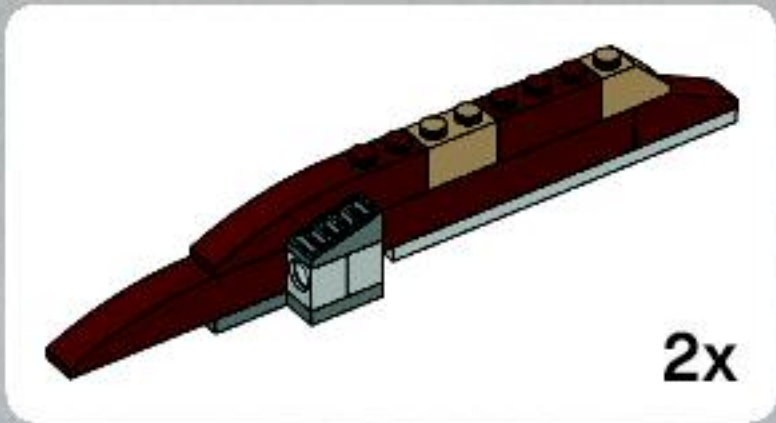

1

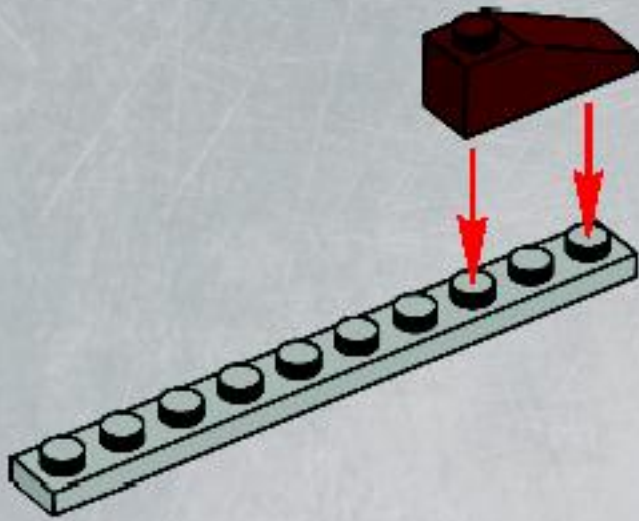

3

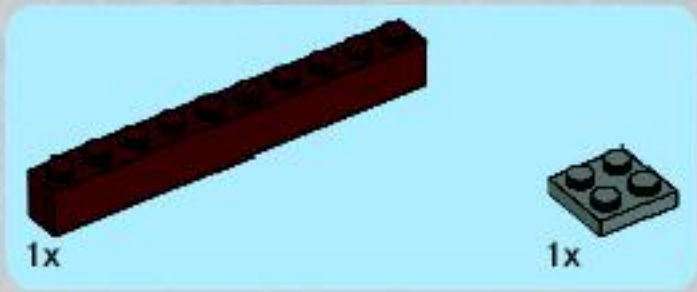
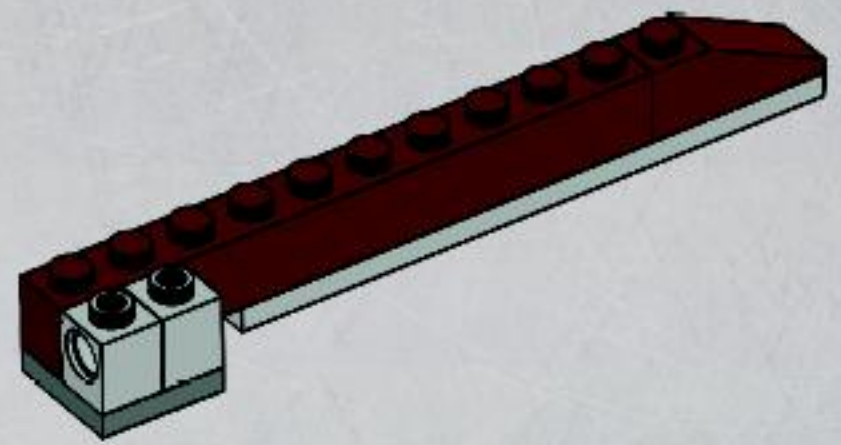

2

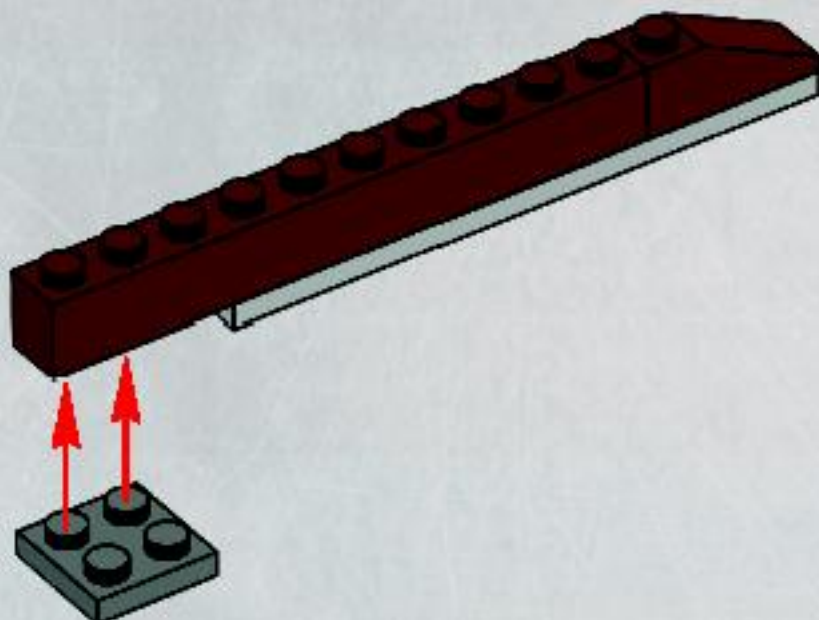

4

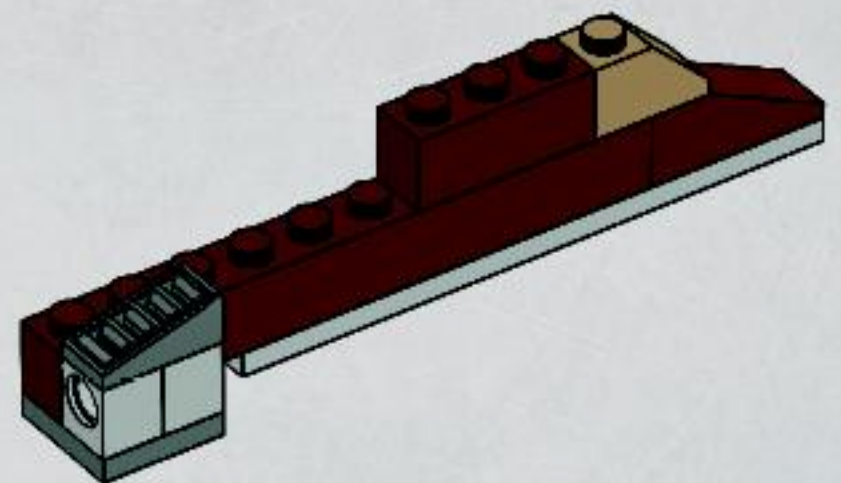

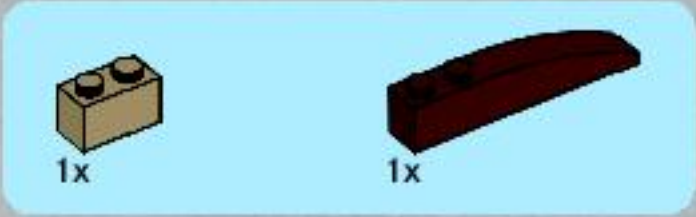

5

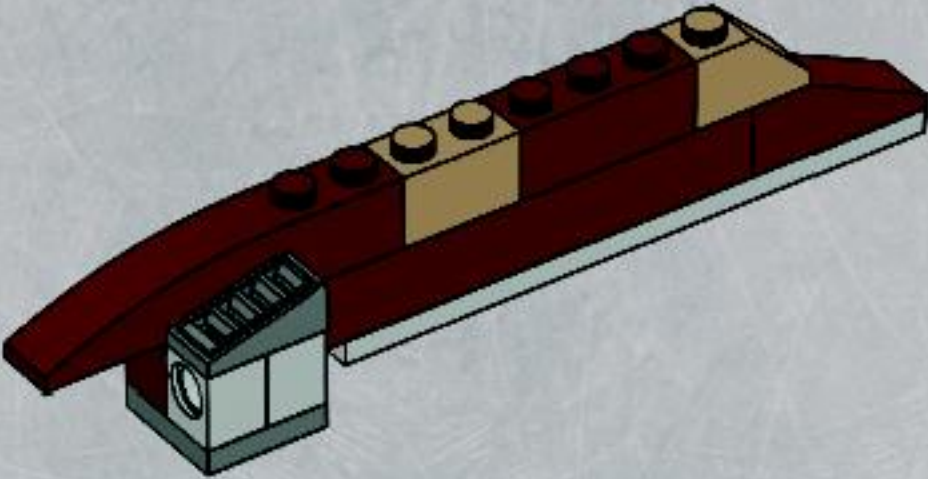

6

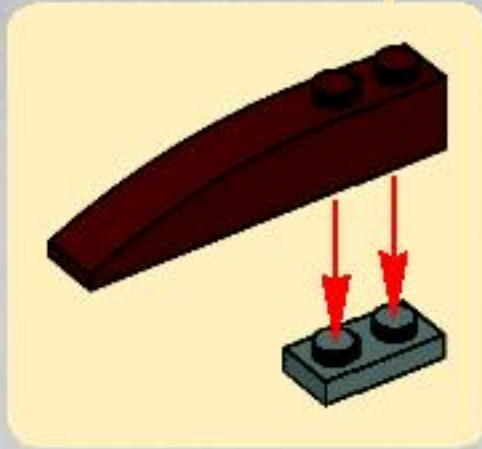
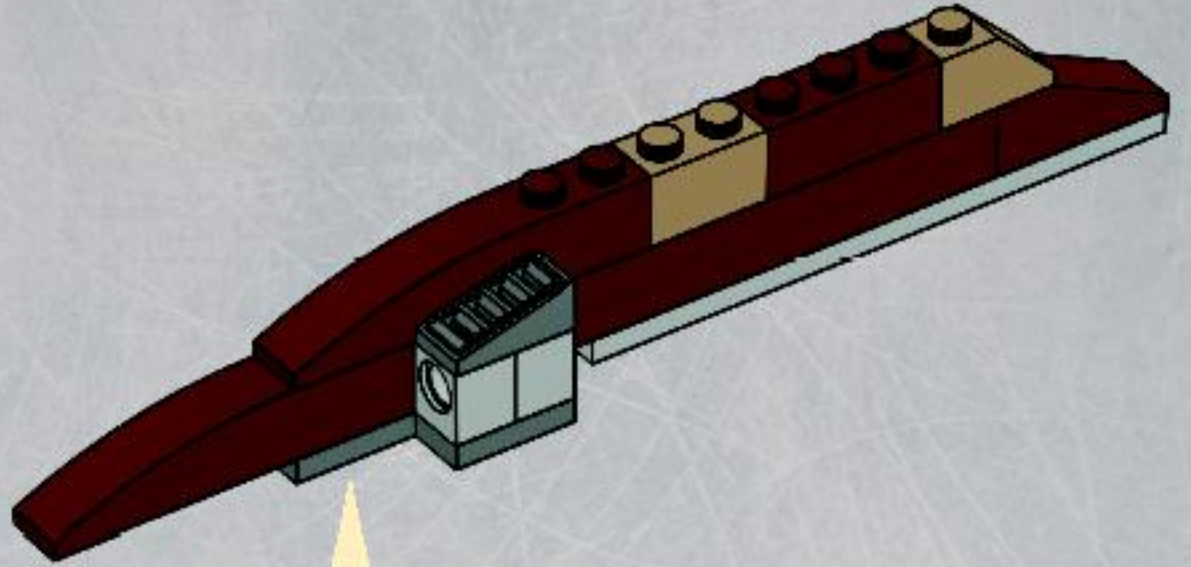

2x

16

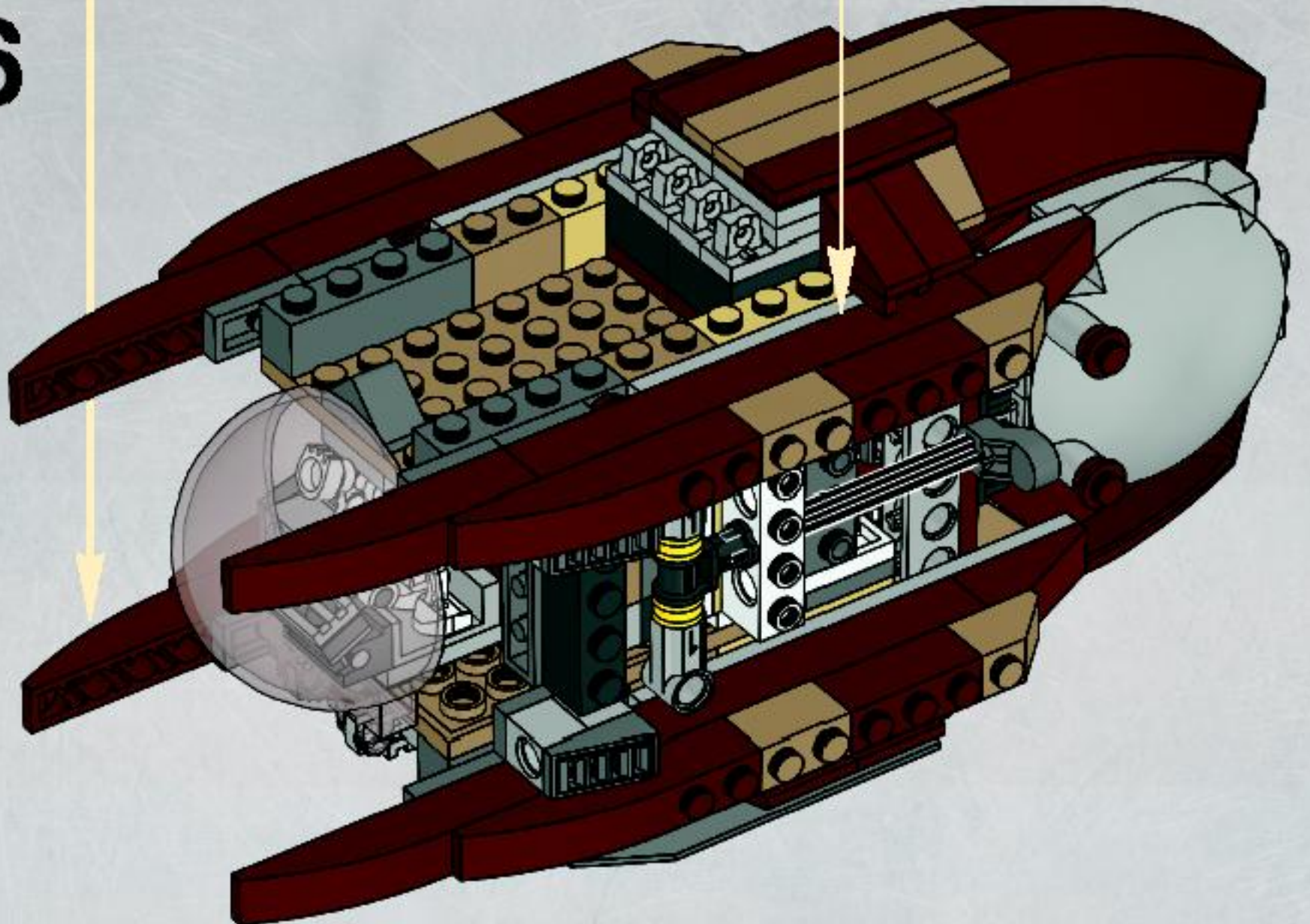

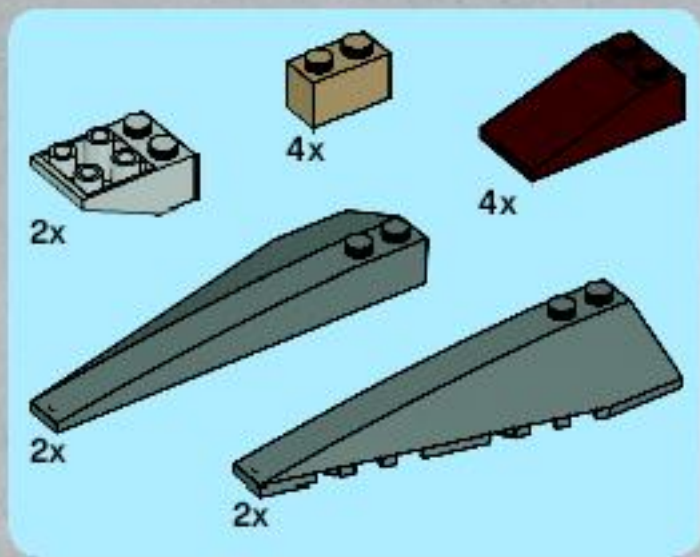

17

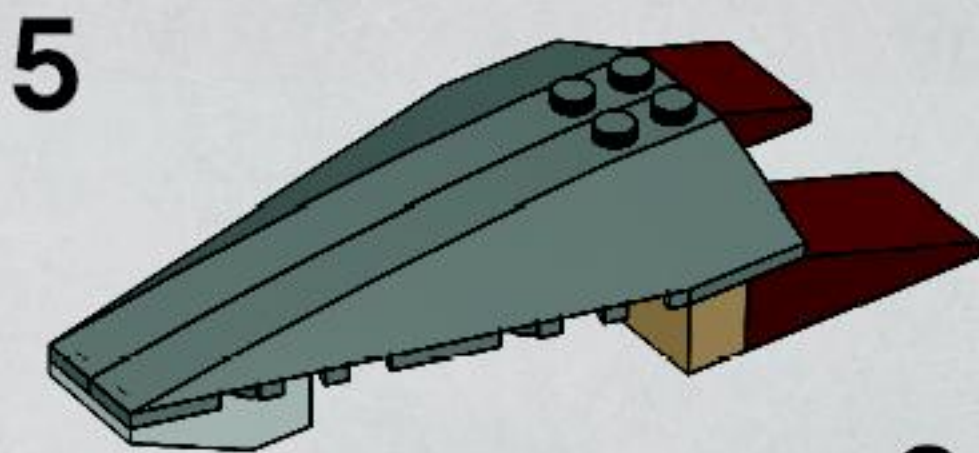
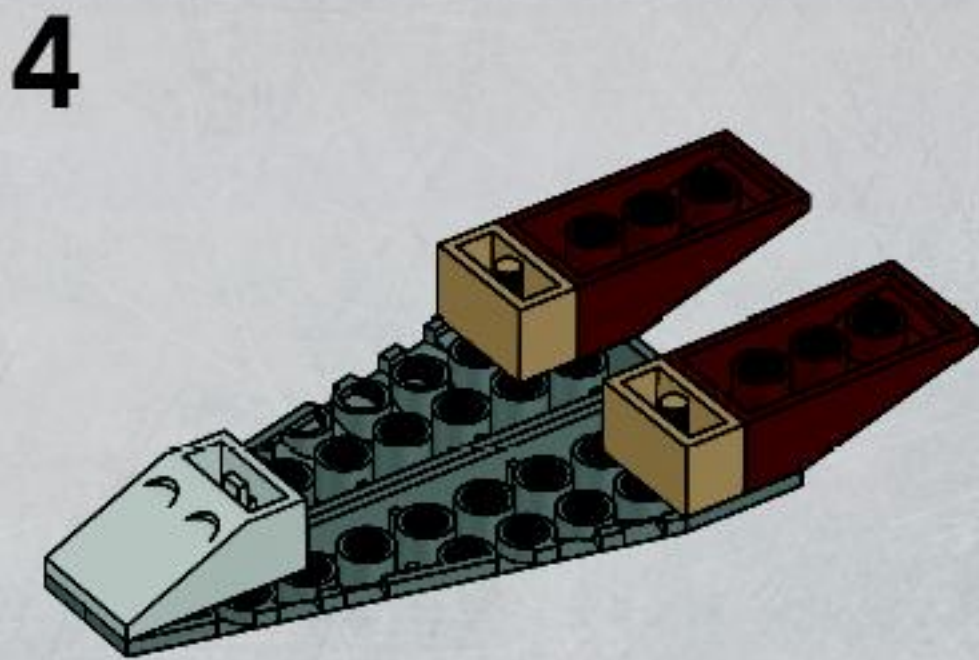
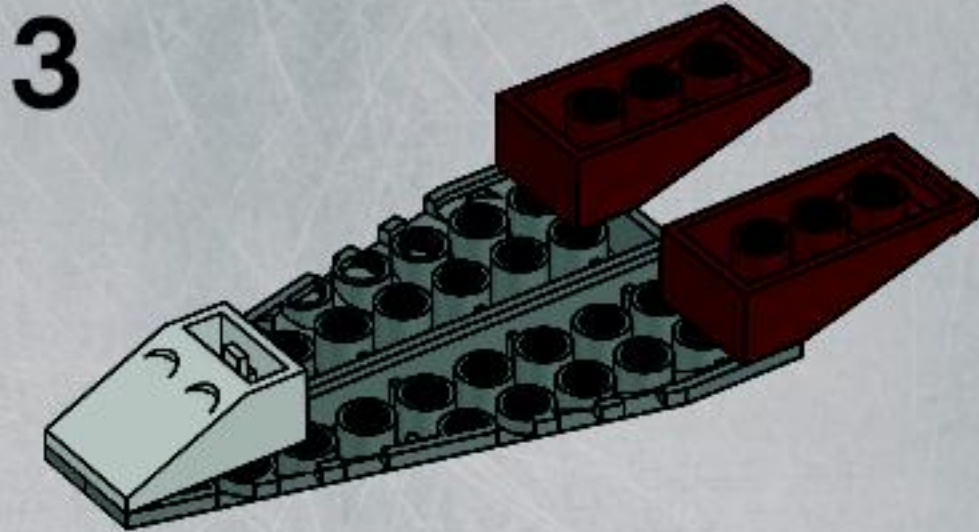
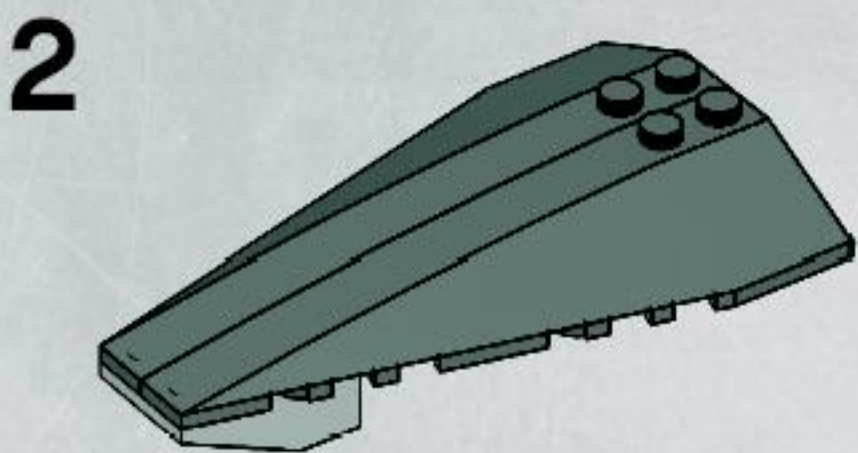
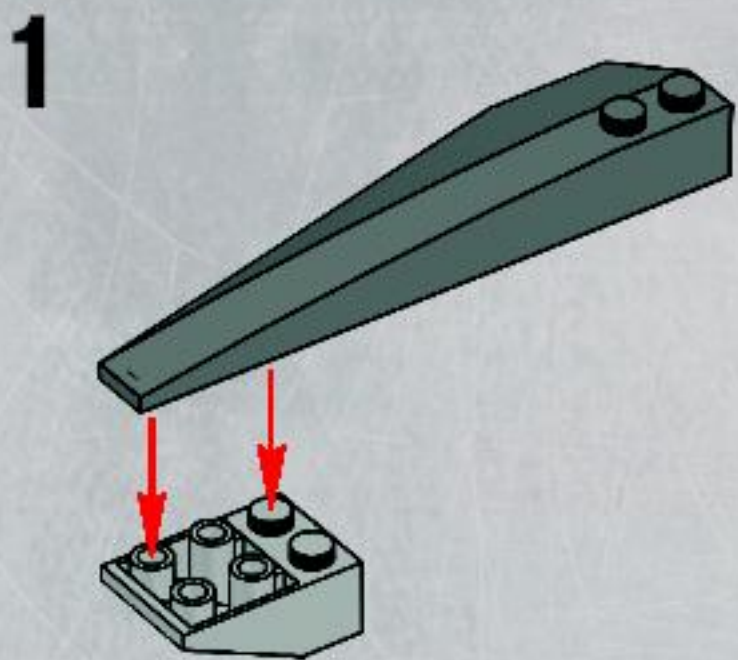

2x

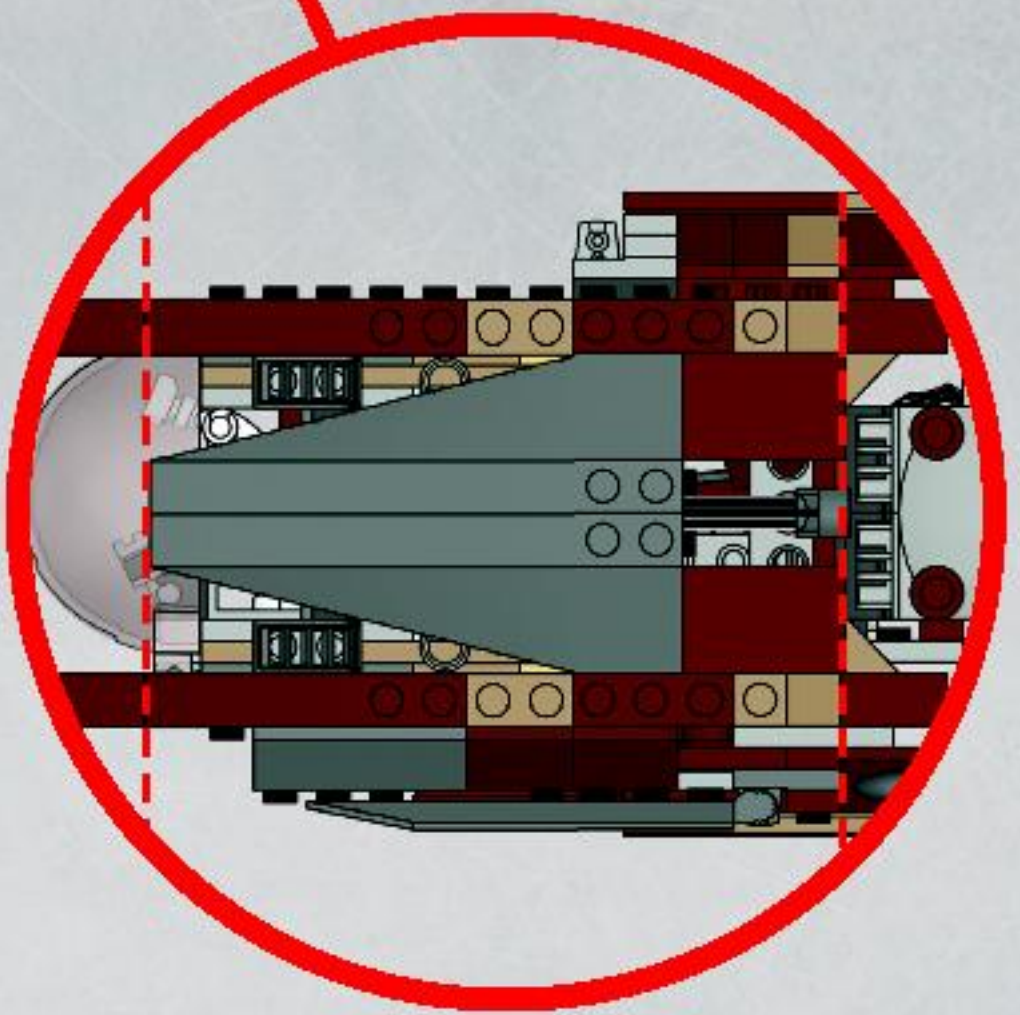
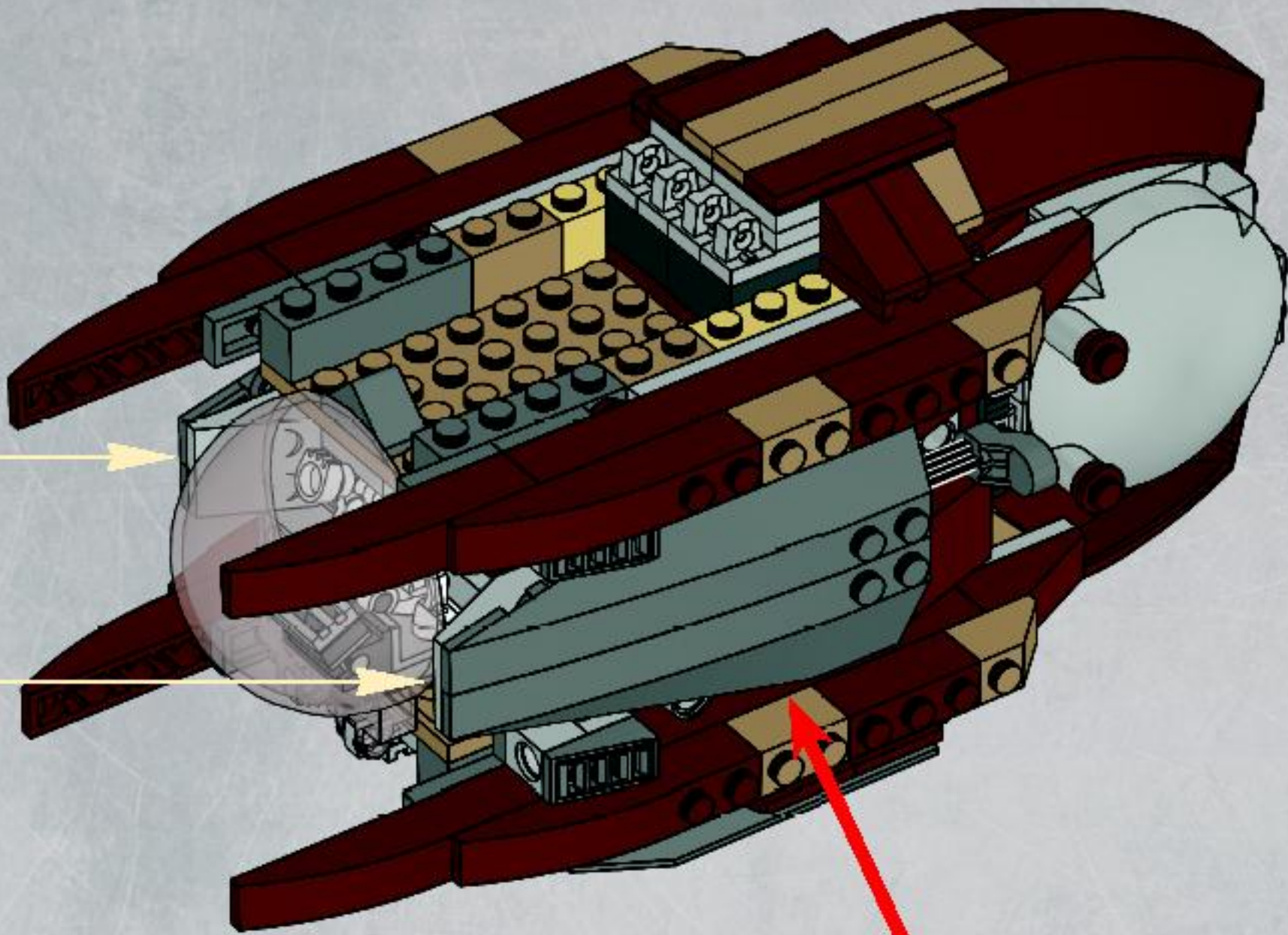



18

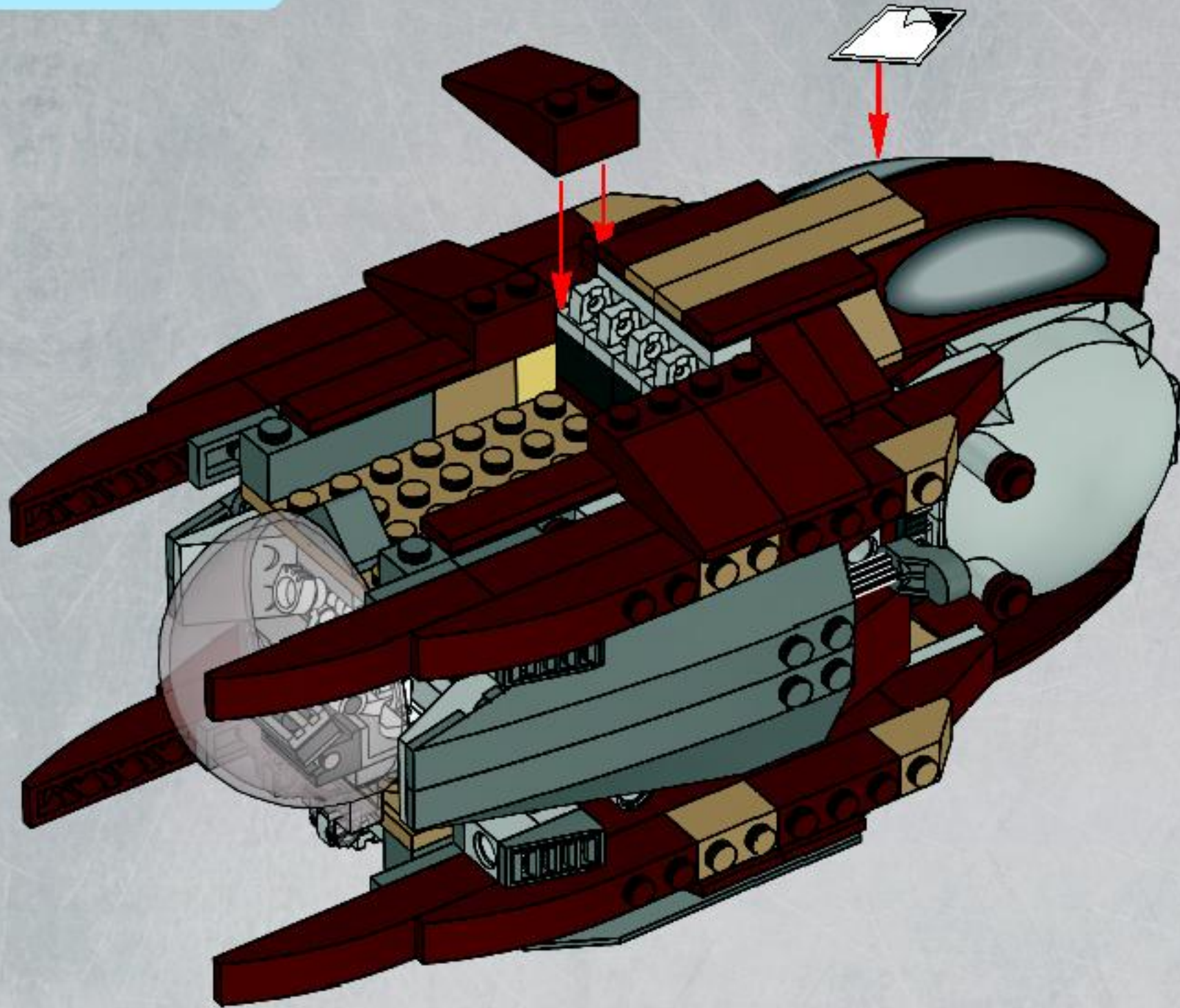

19

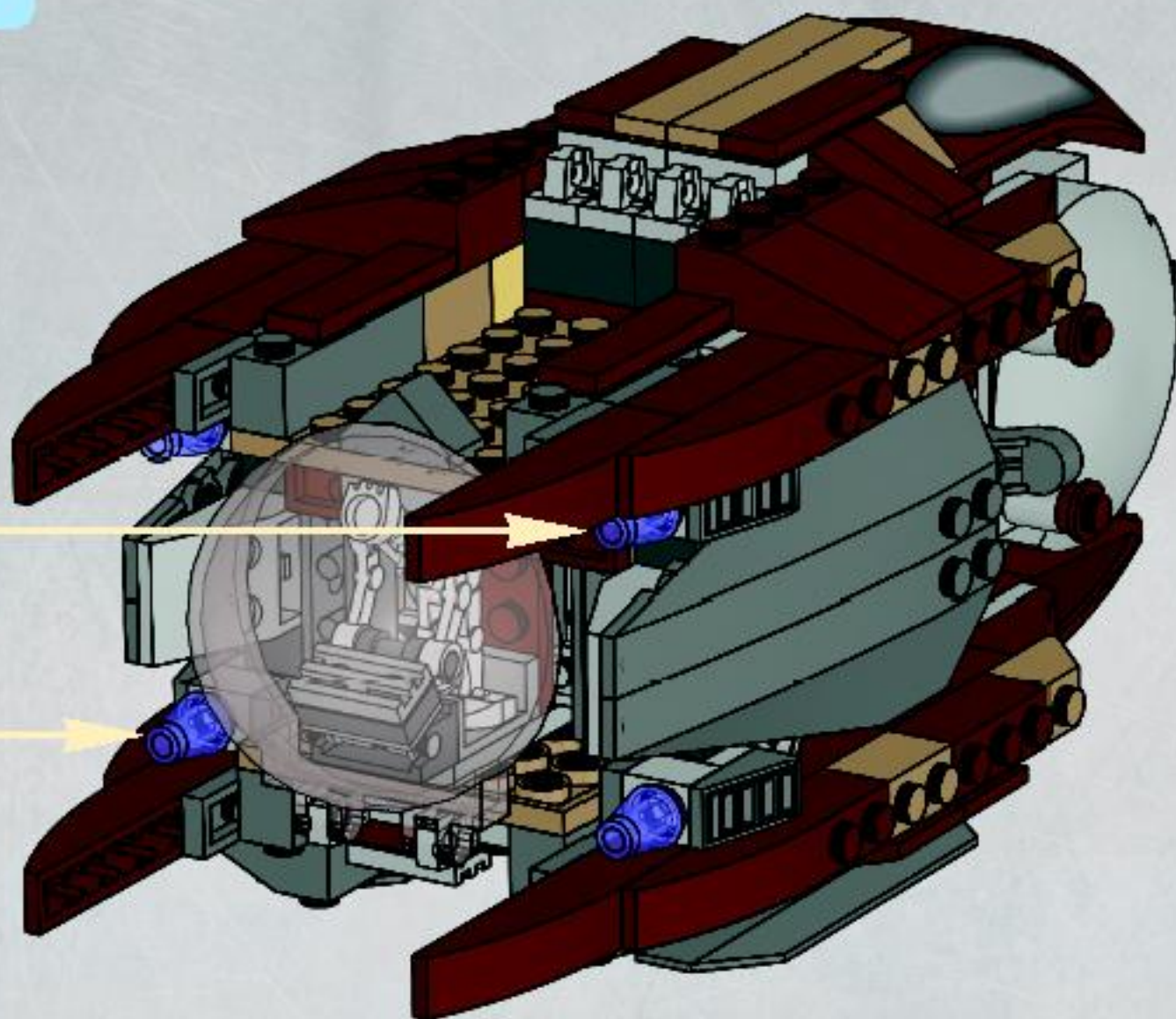
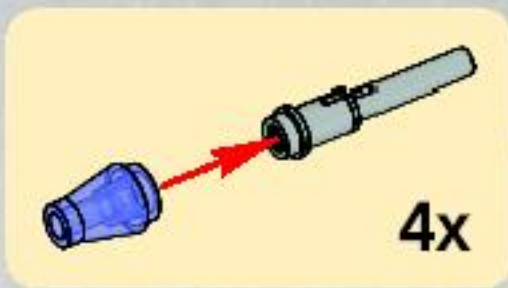



20

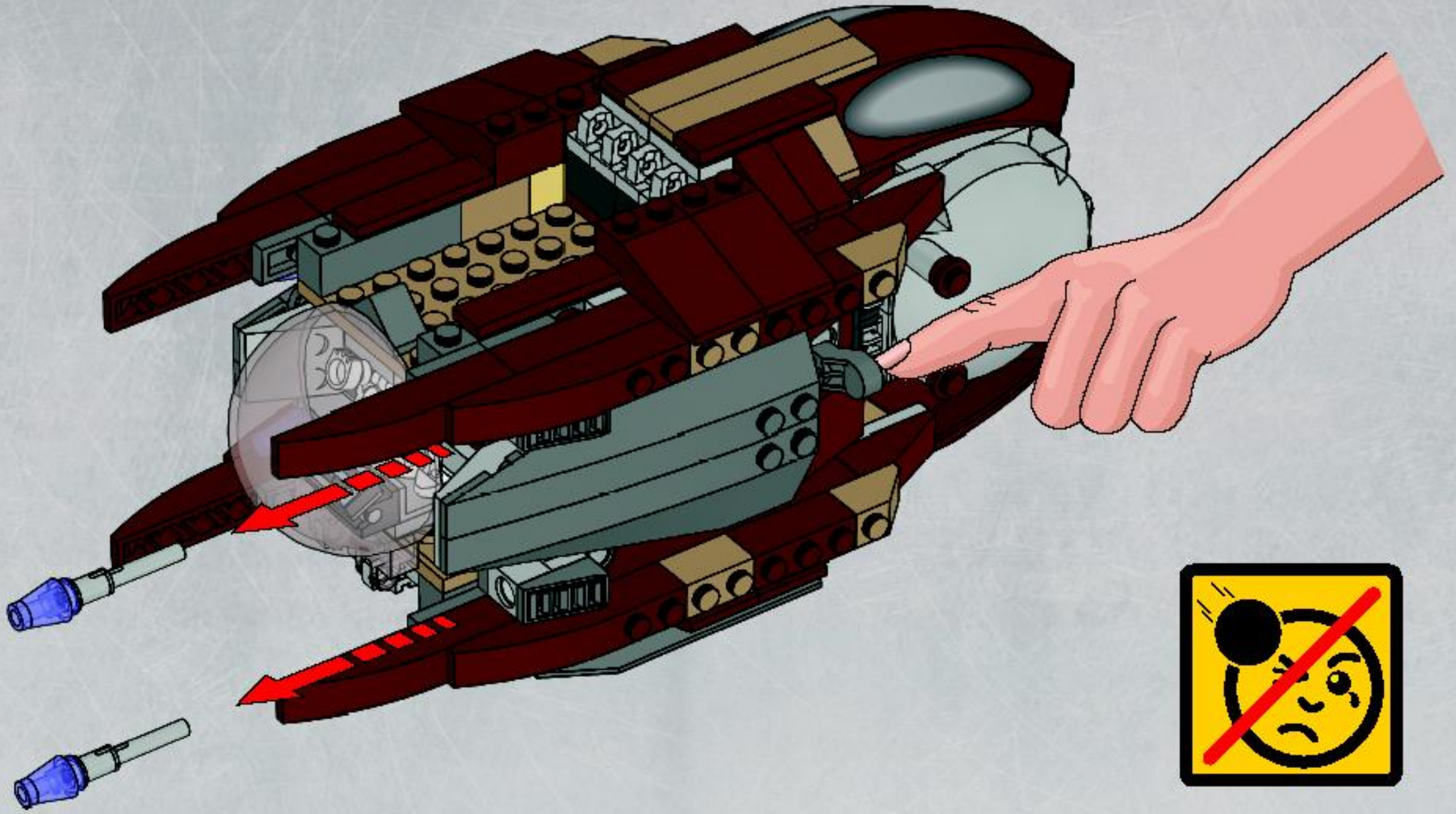

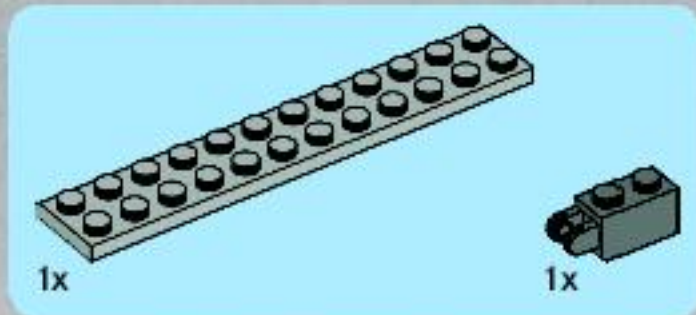

1

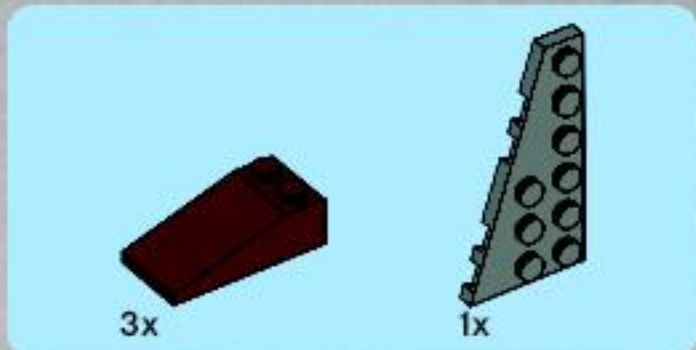
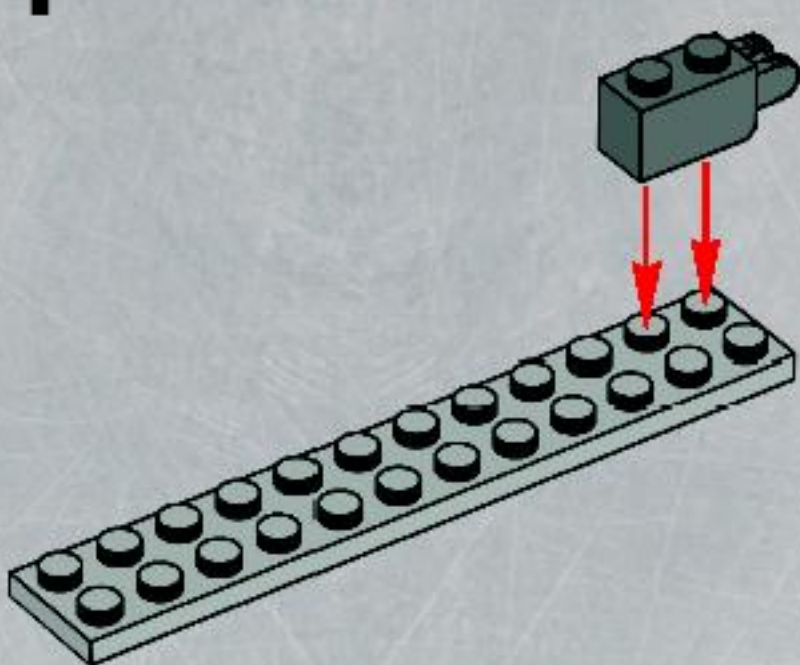

3

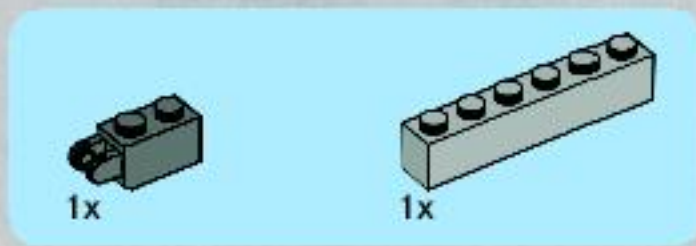
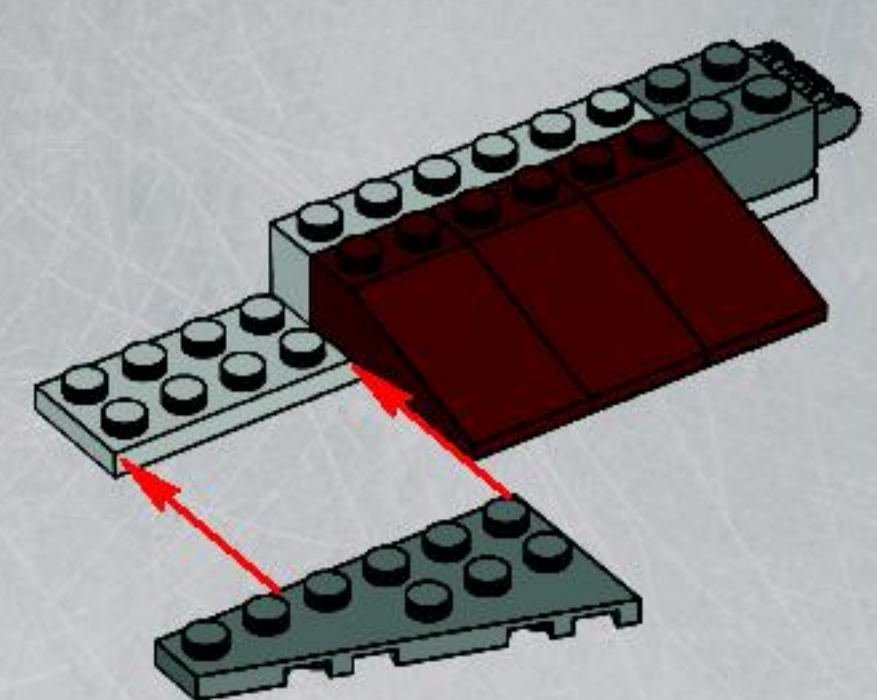

2

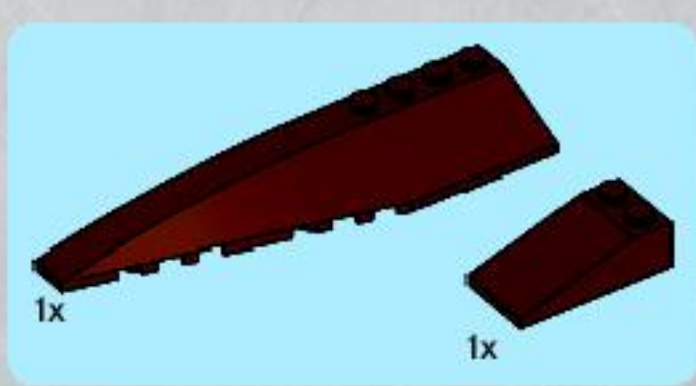
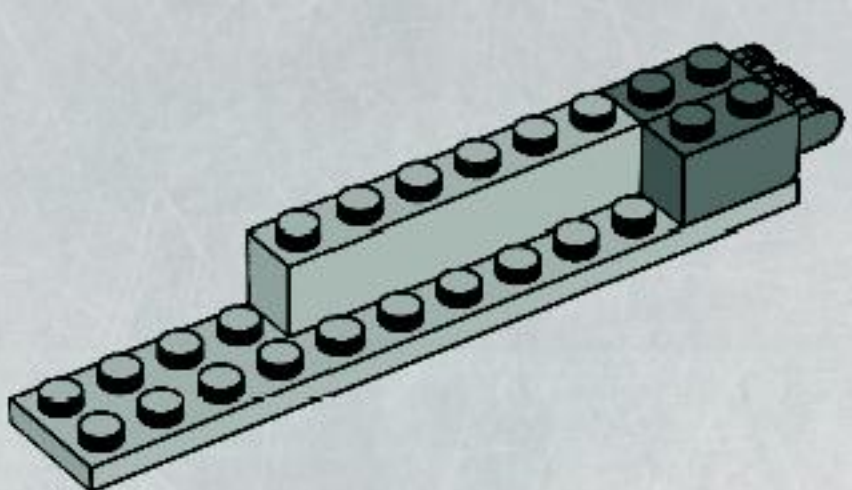

4

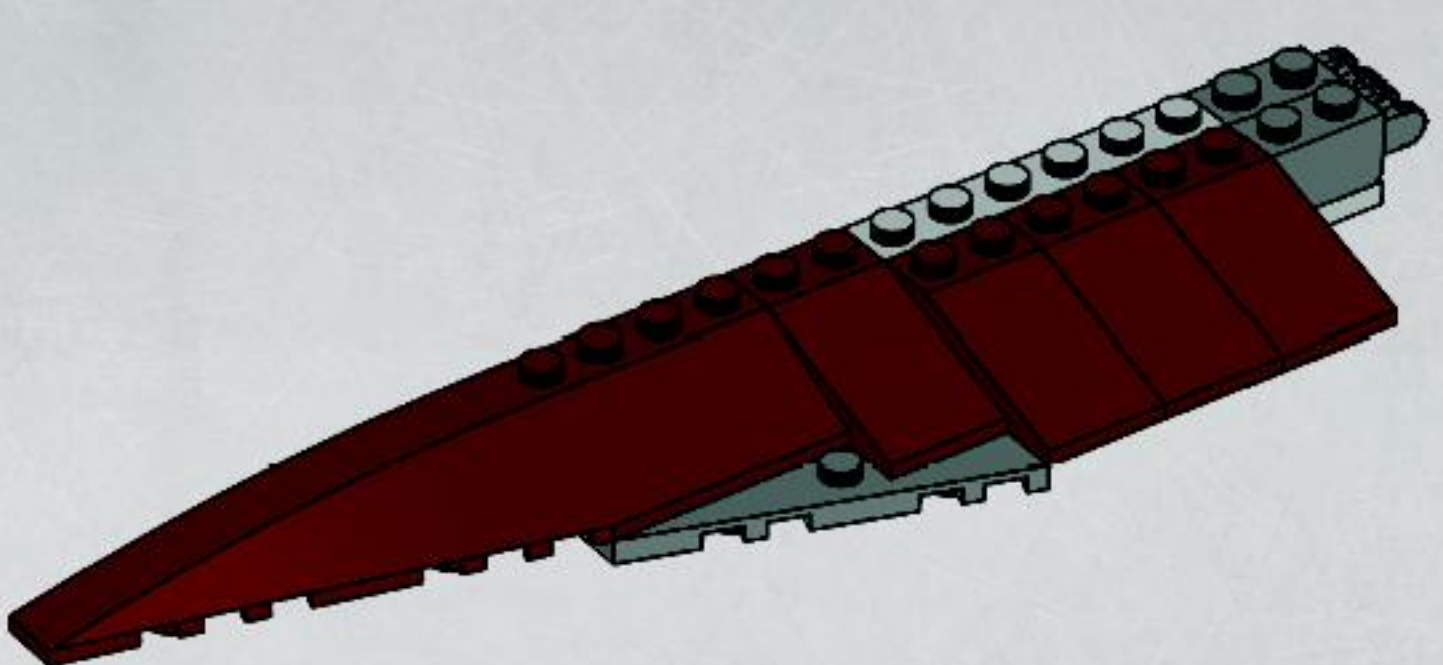

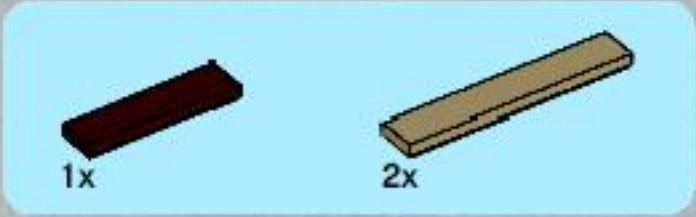

5

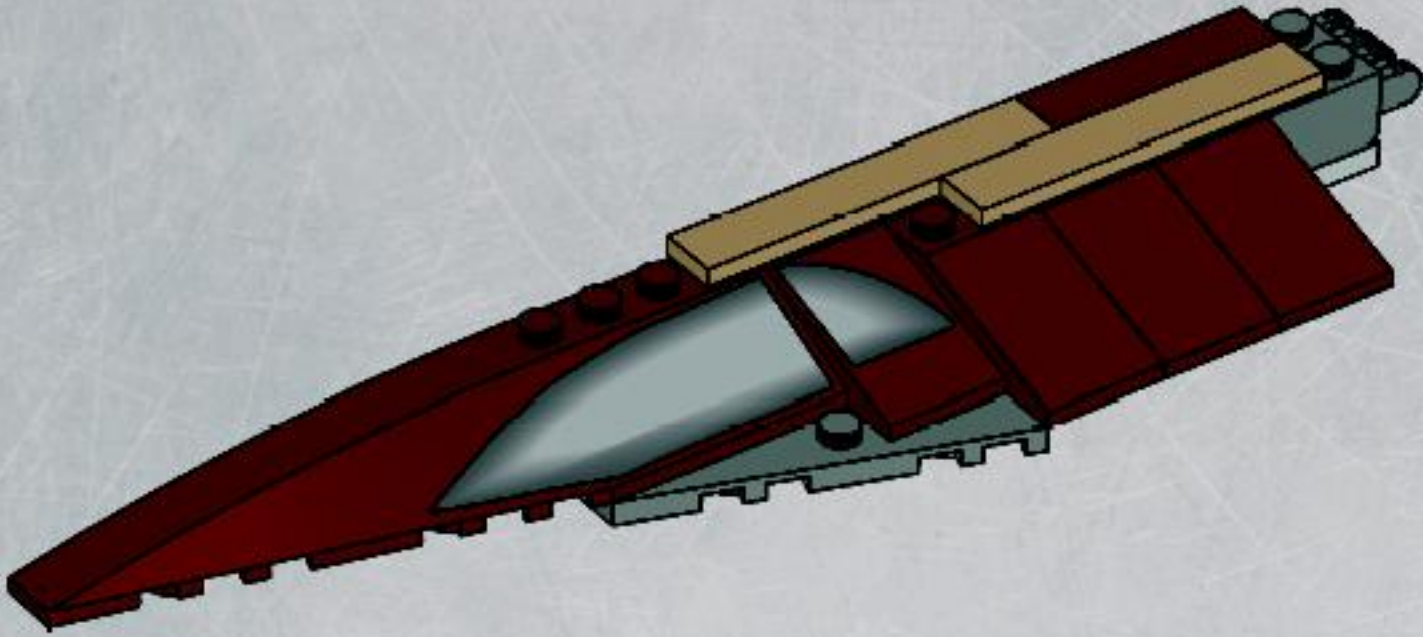

21

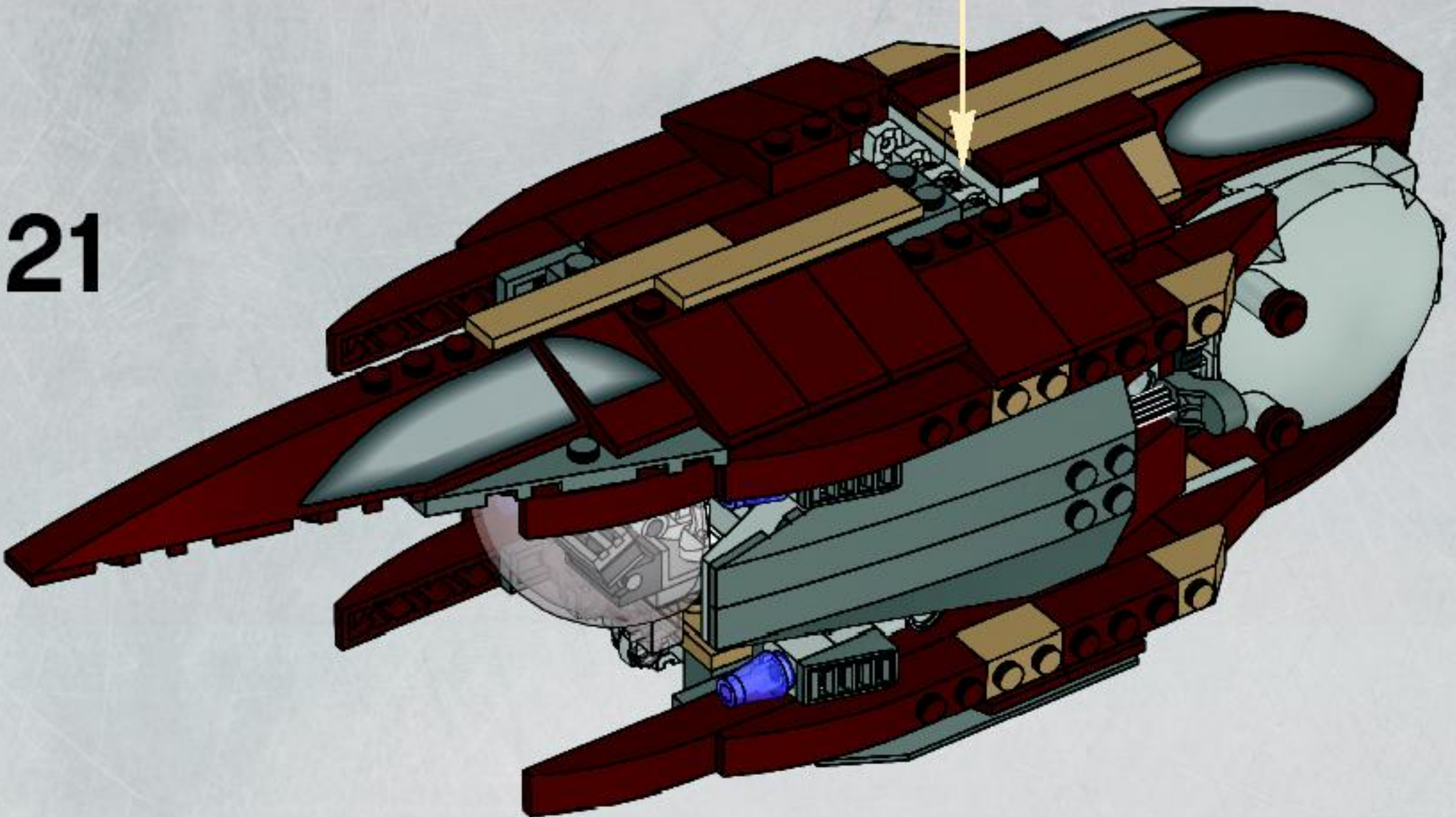

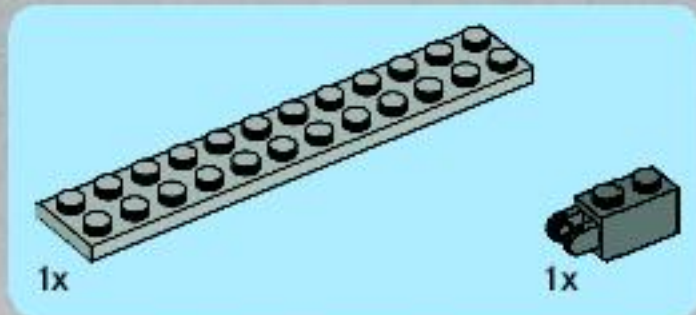

1

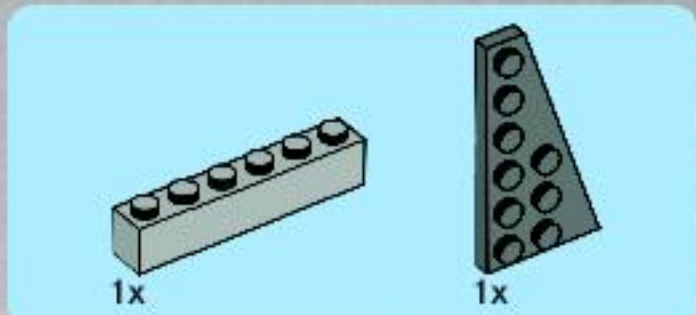
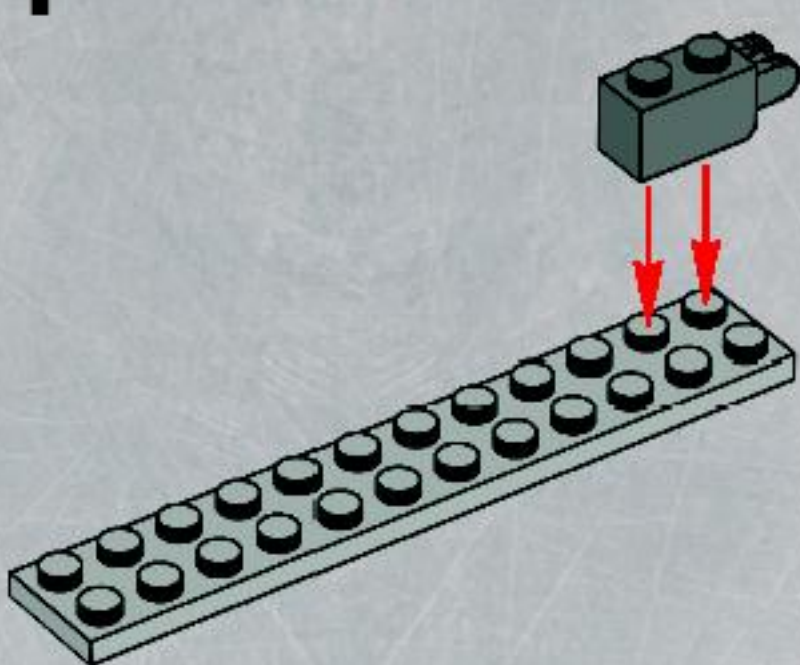

3

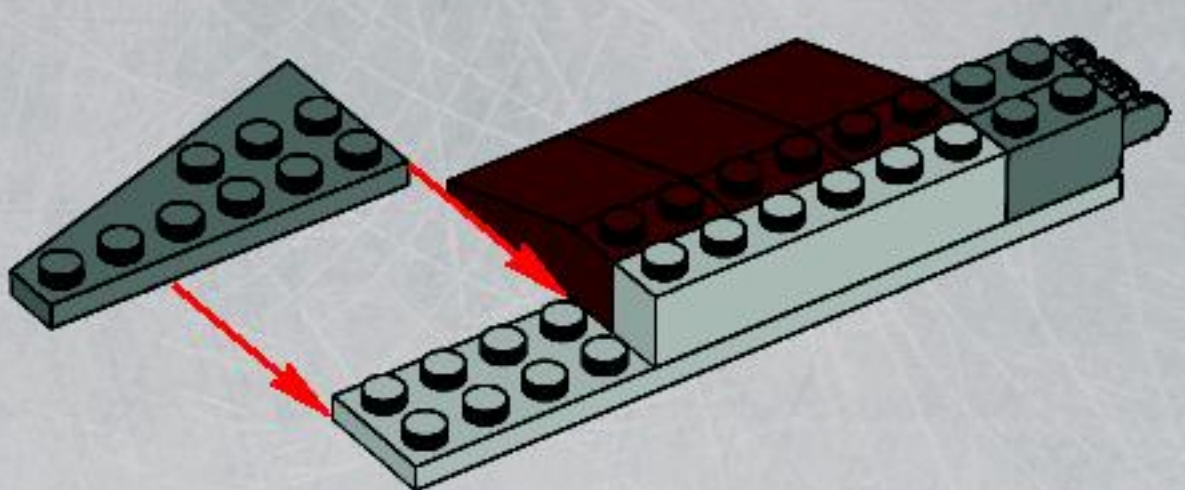

2

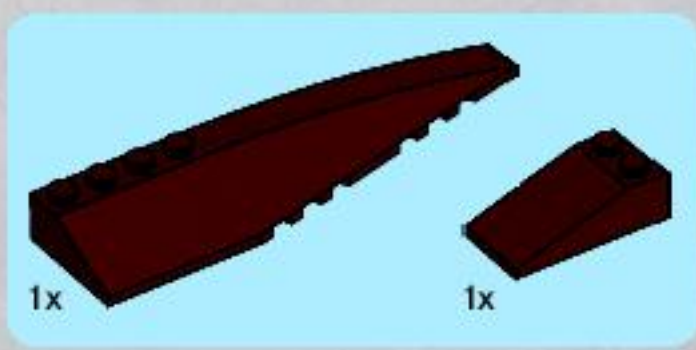
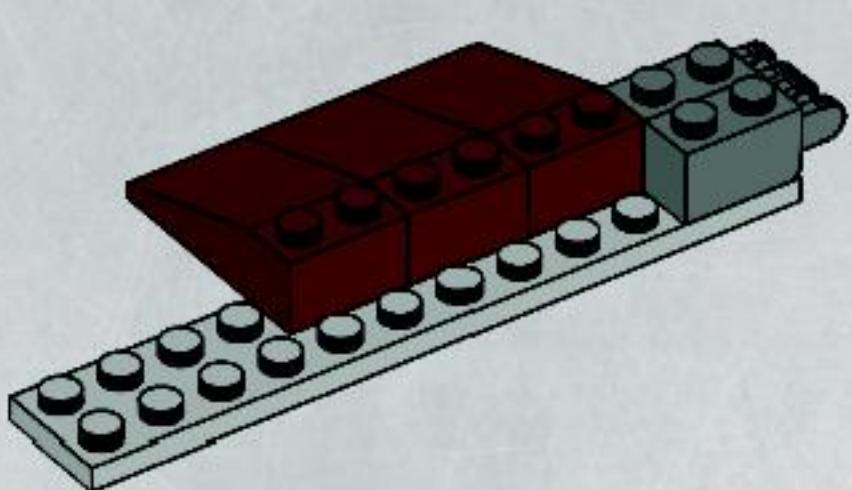

4

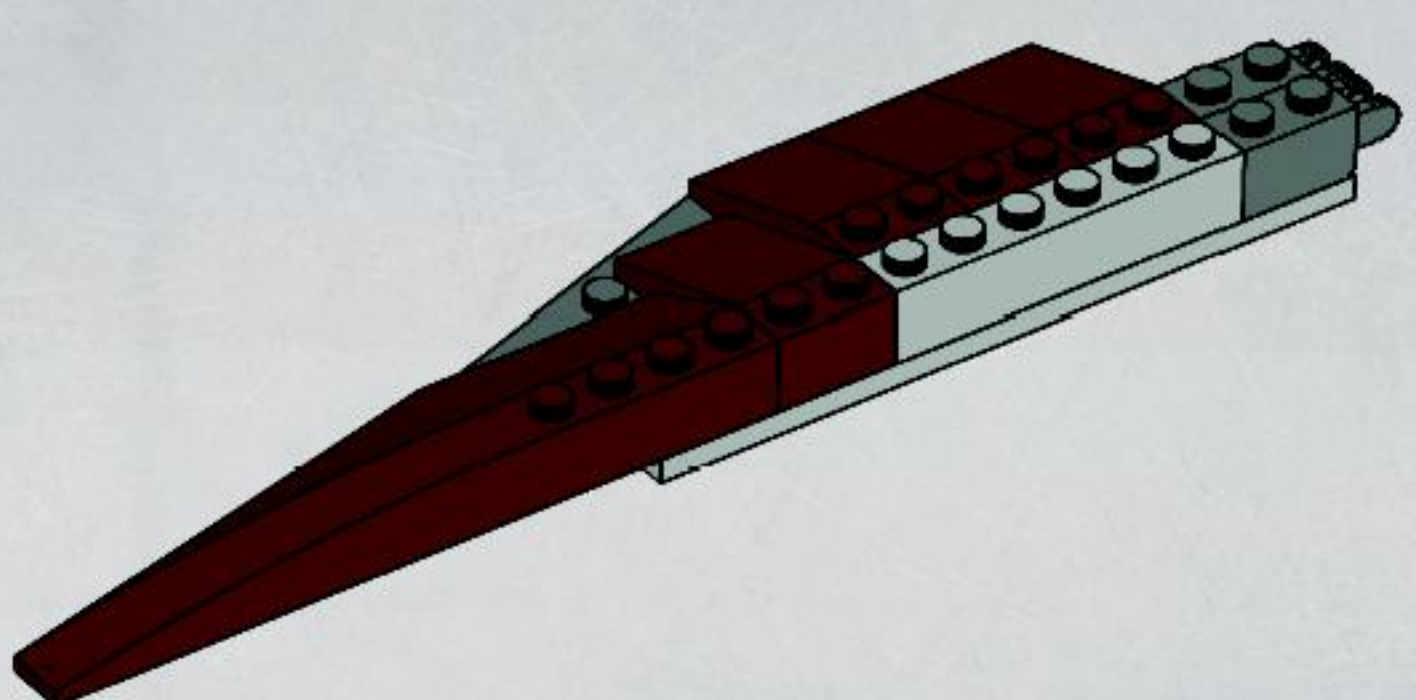

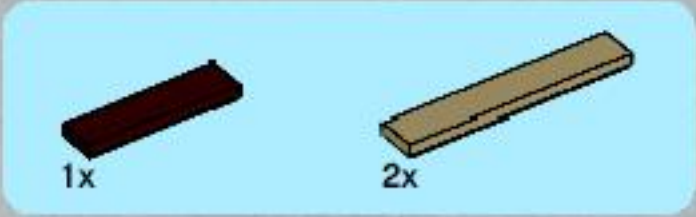

5

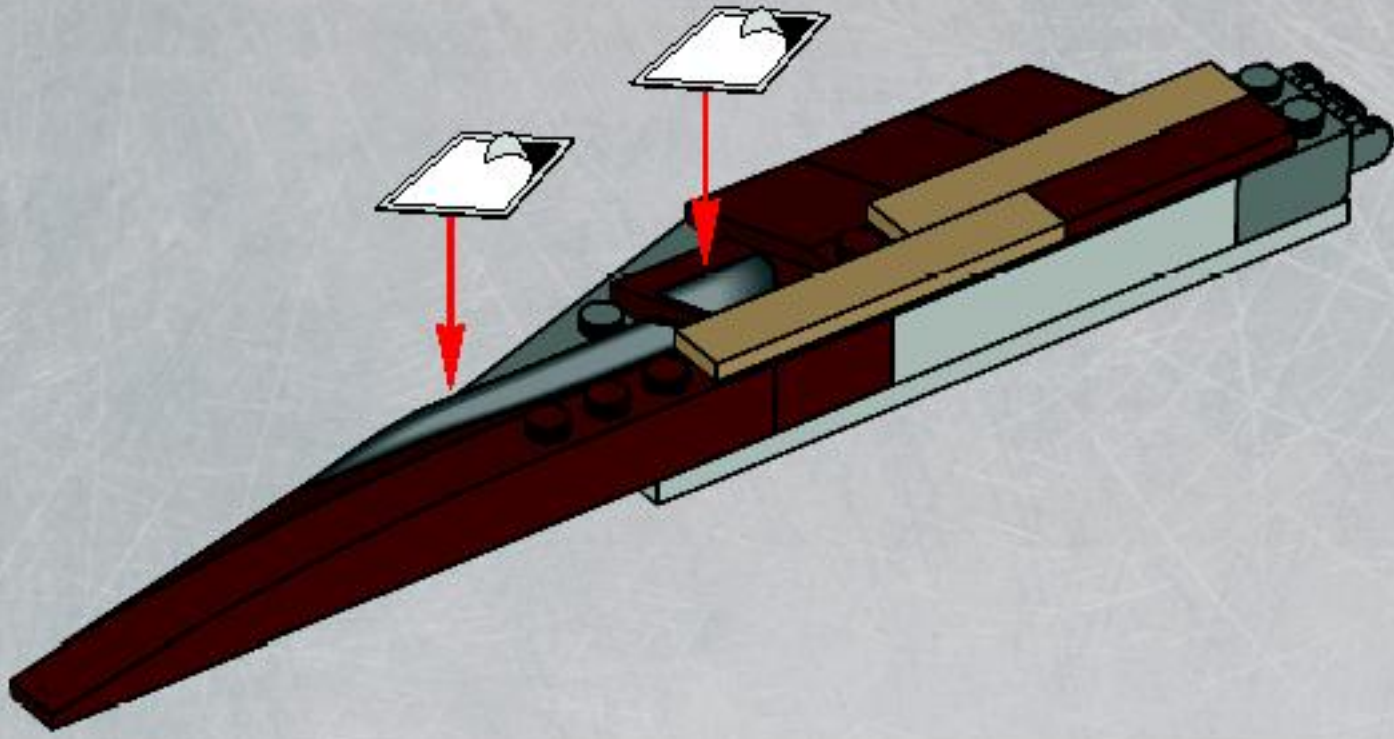

22

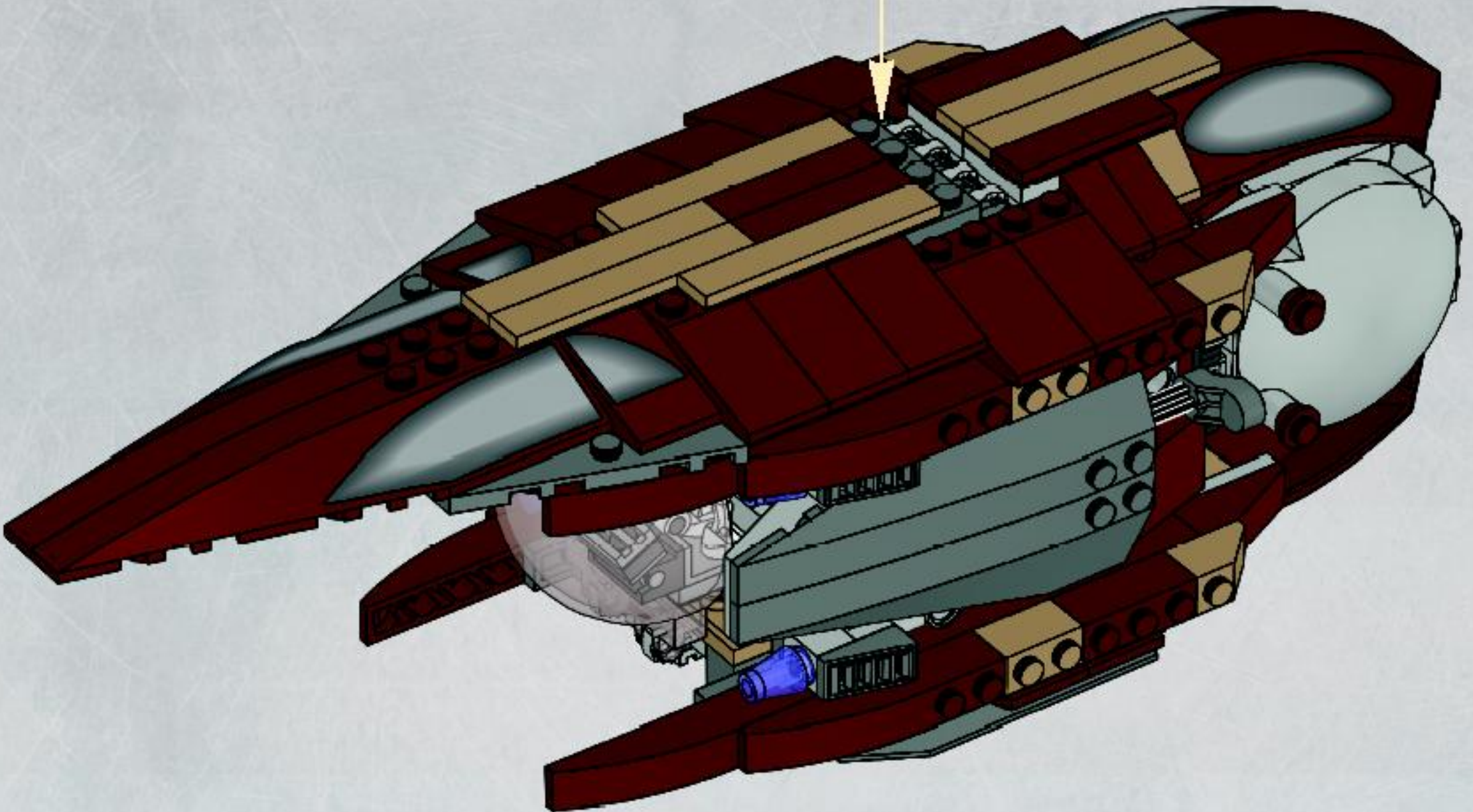

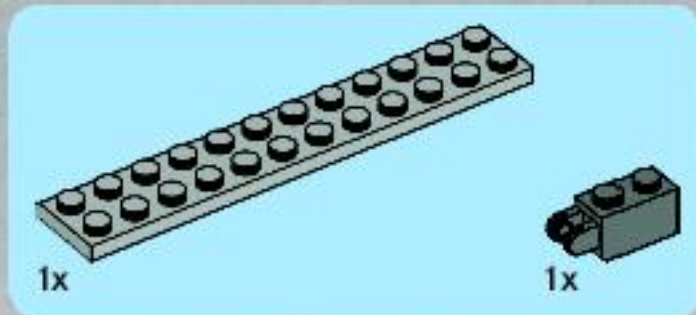

1

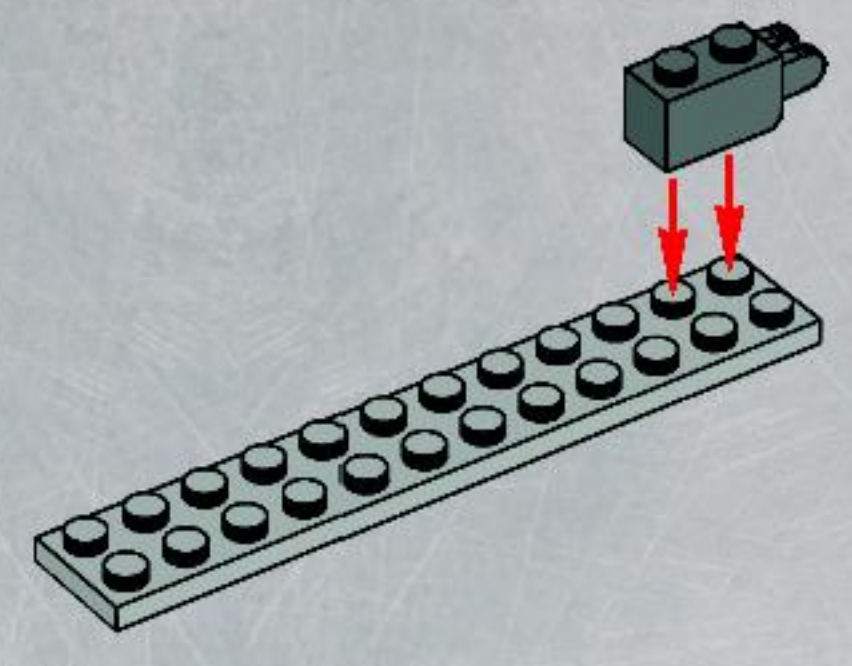

2

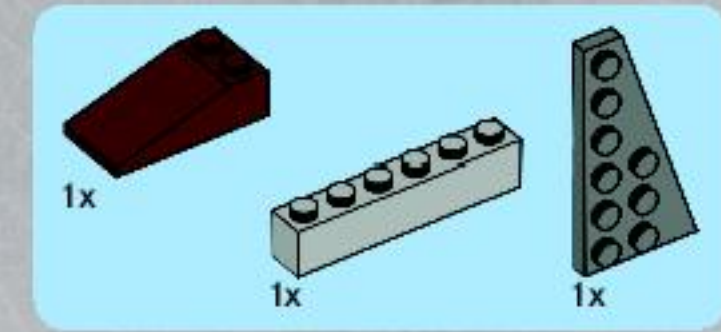
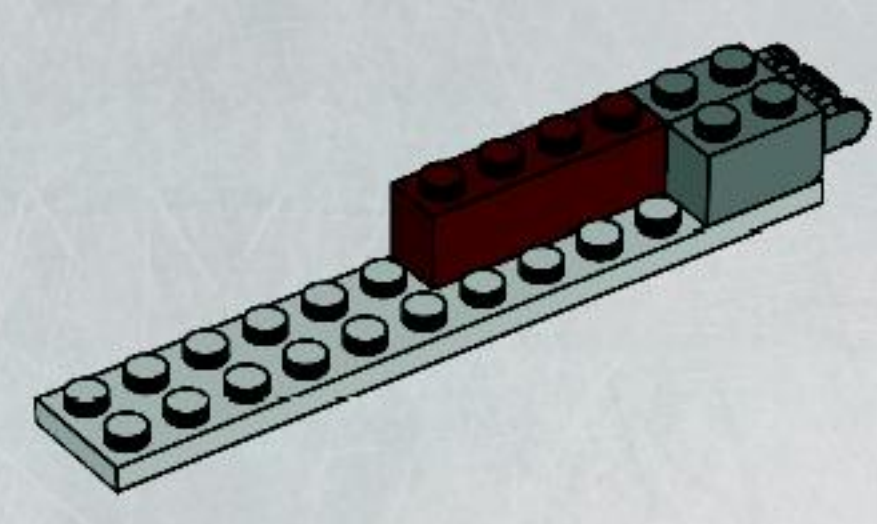

3

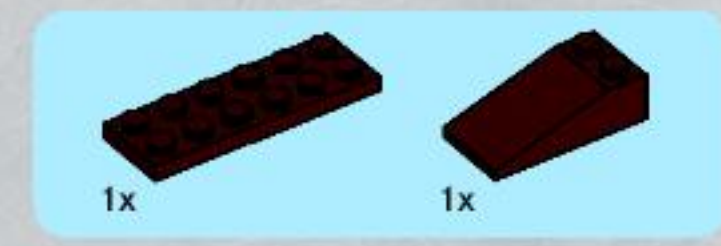
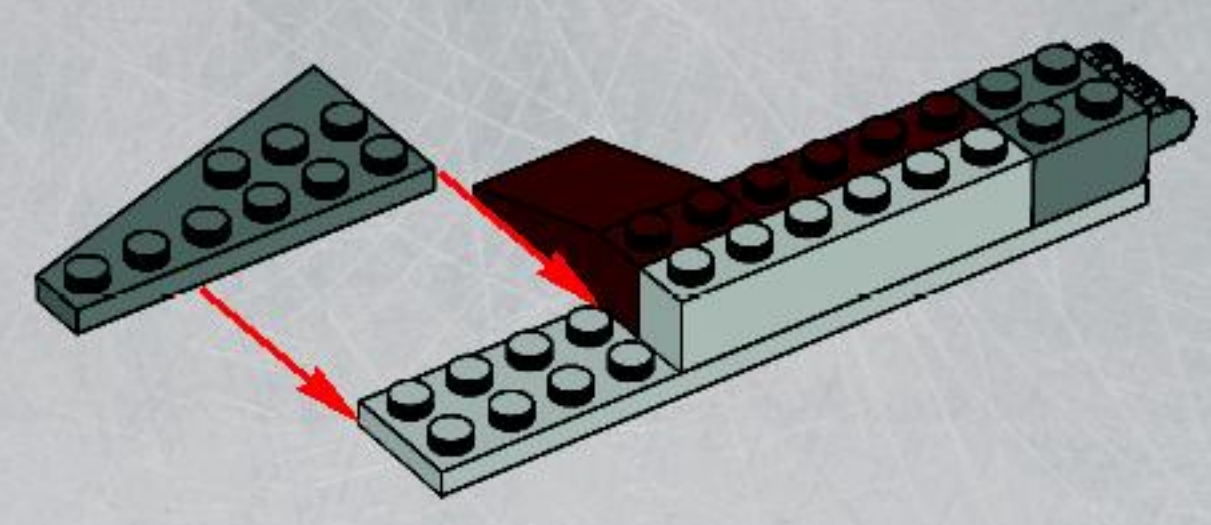

4

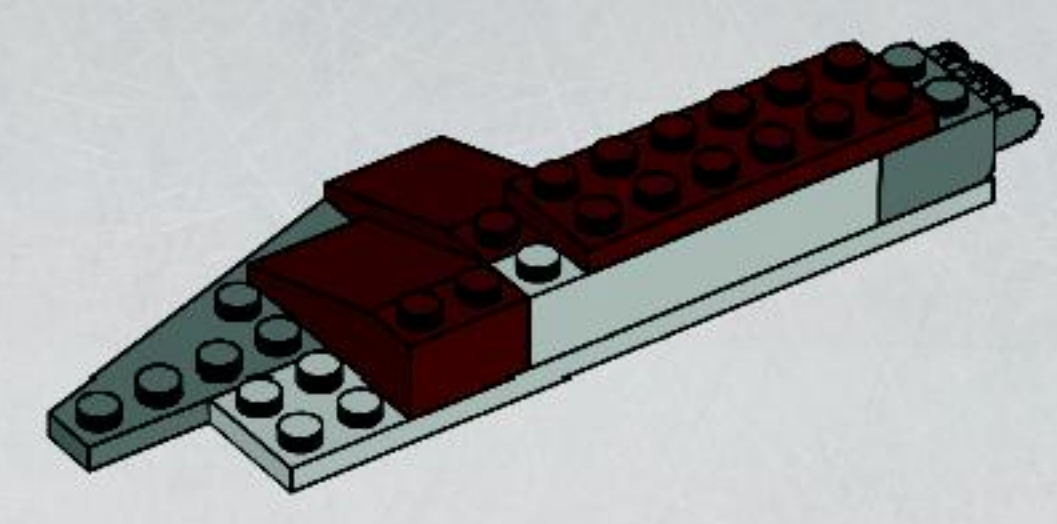

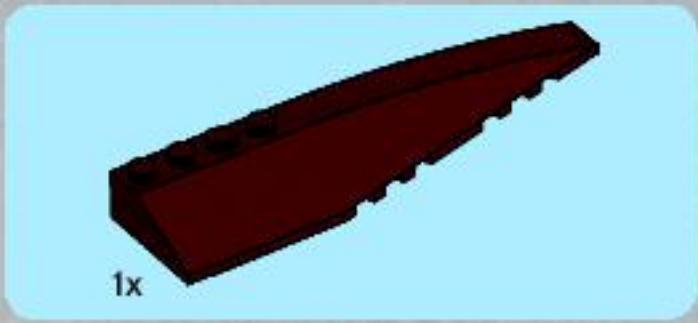

5

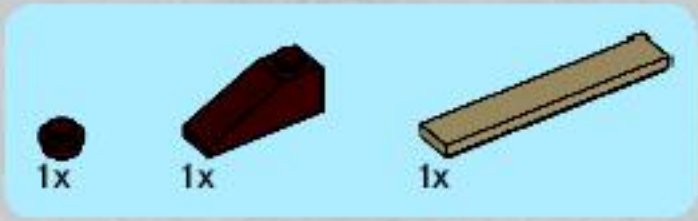
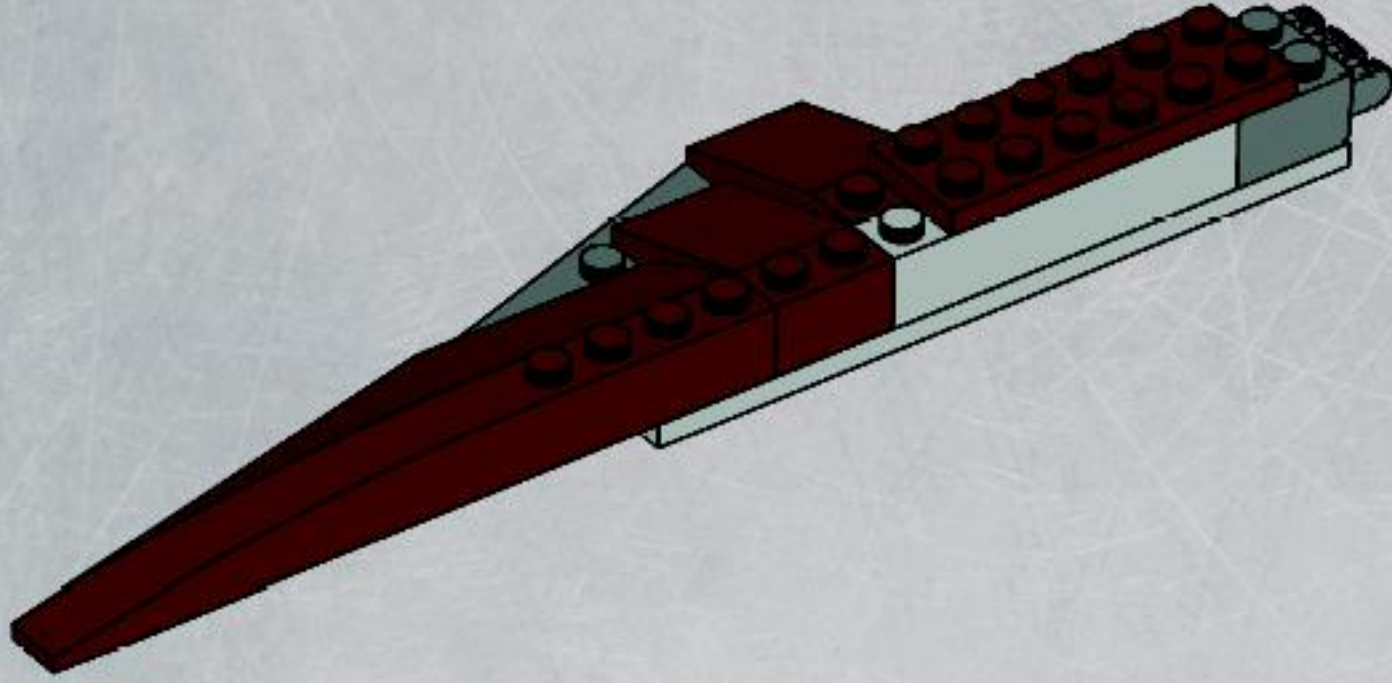

6

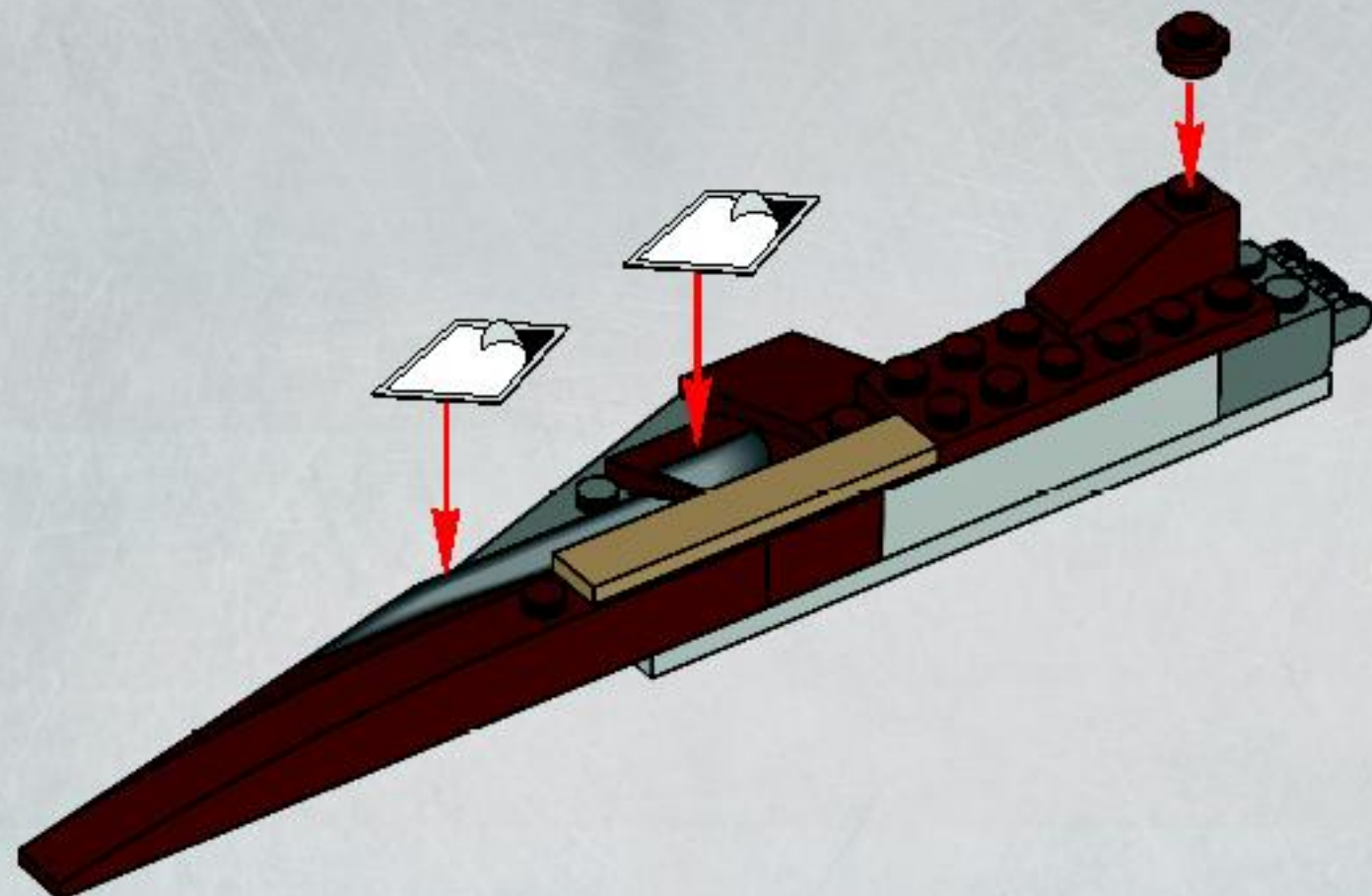

23

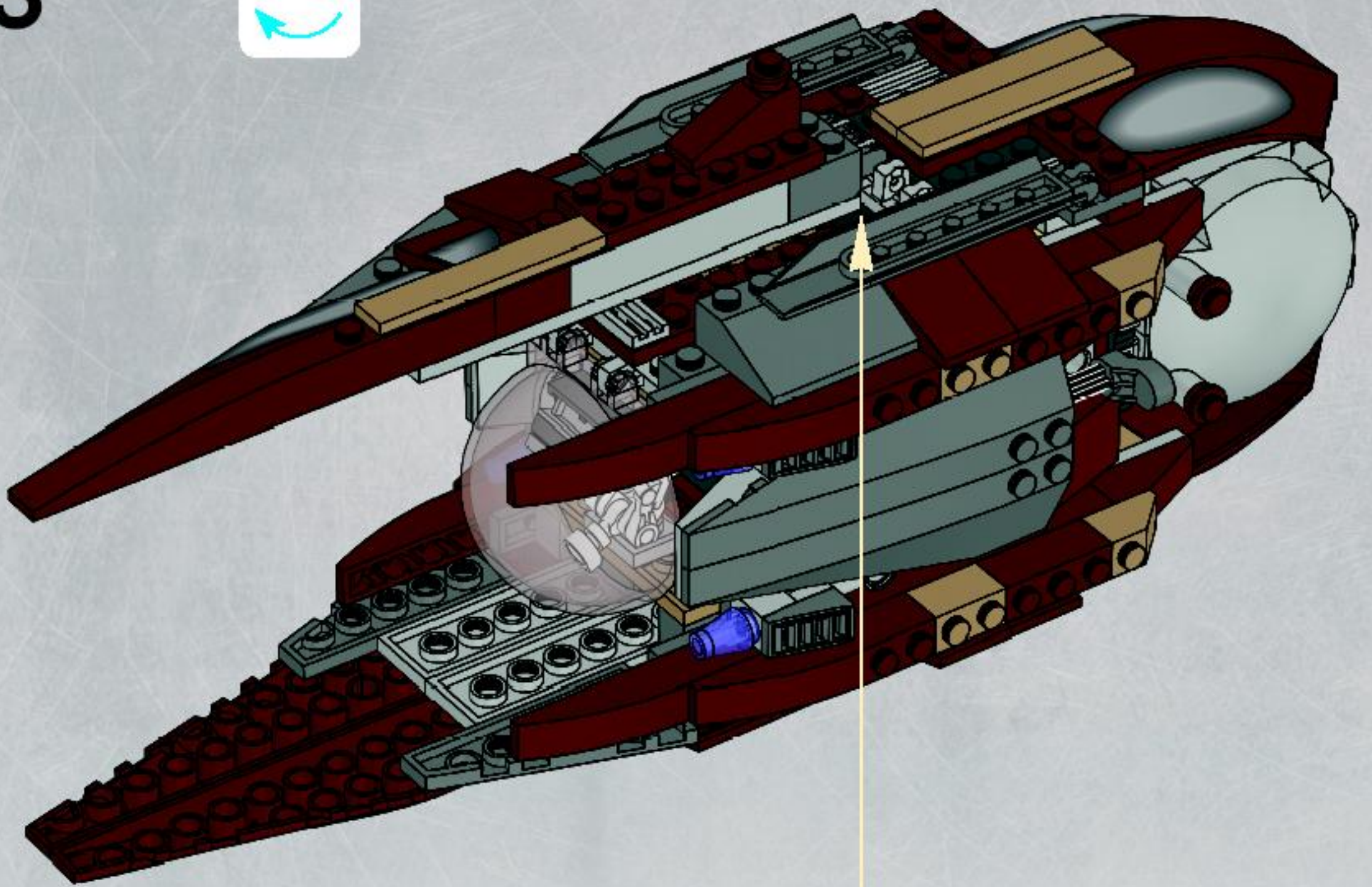

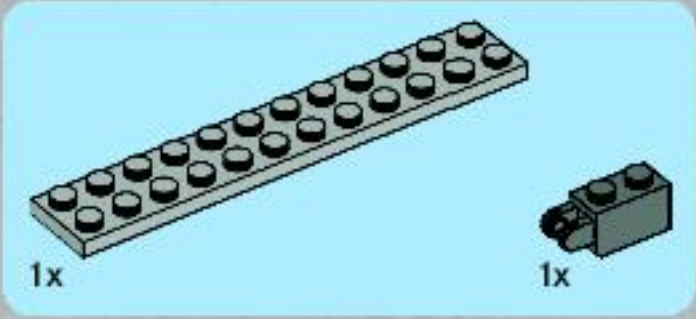

1

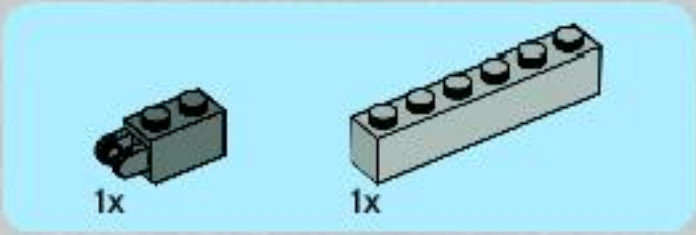
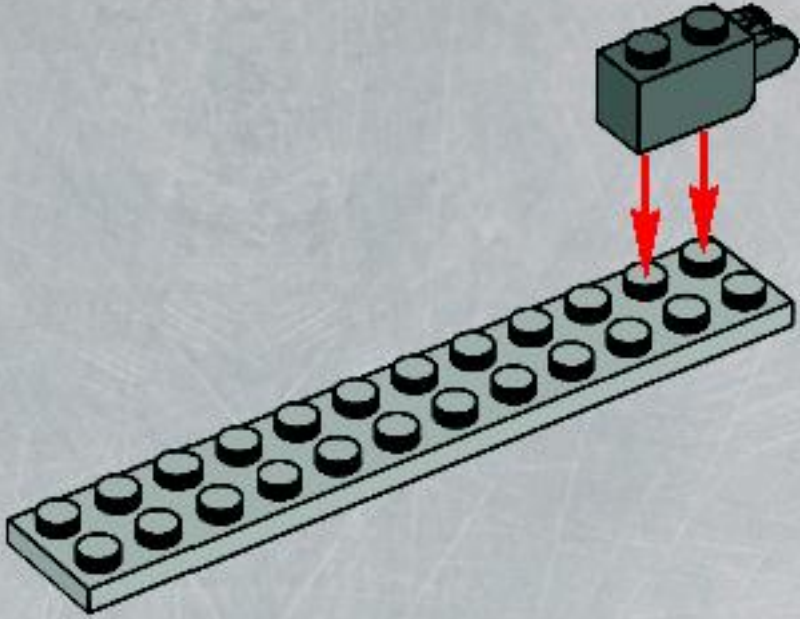

2

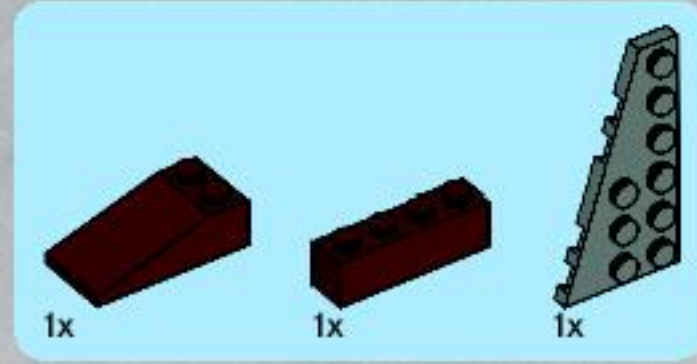
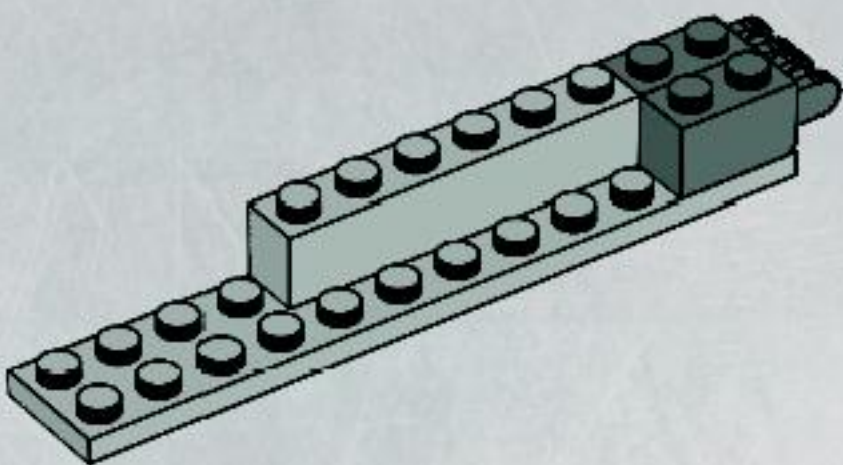

3

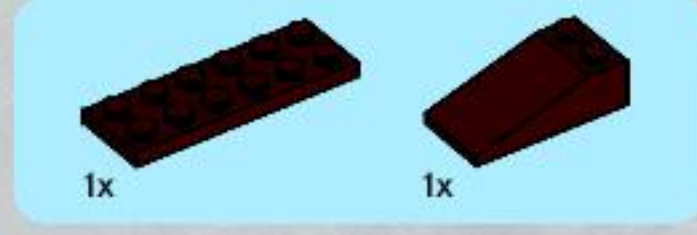
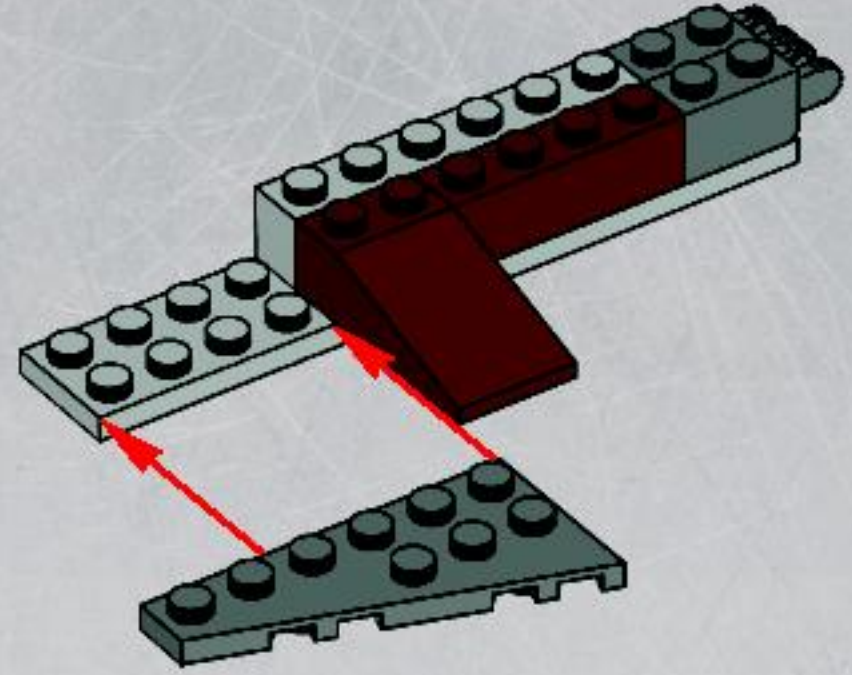

4

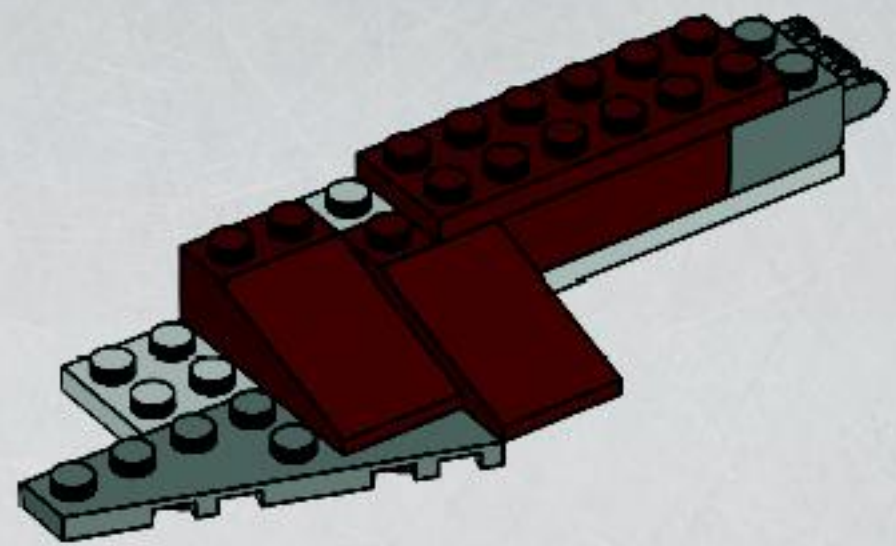

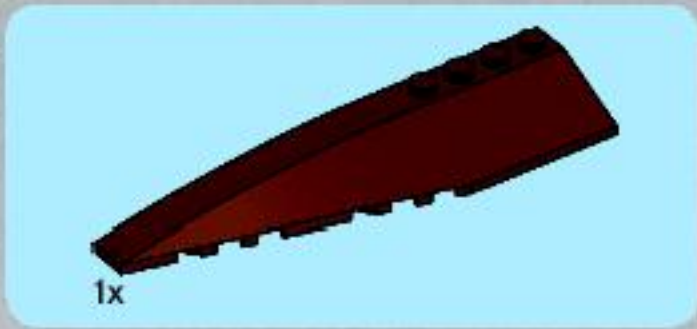

5

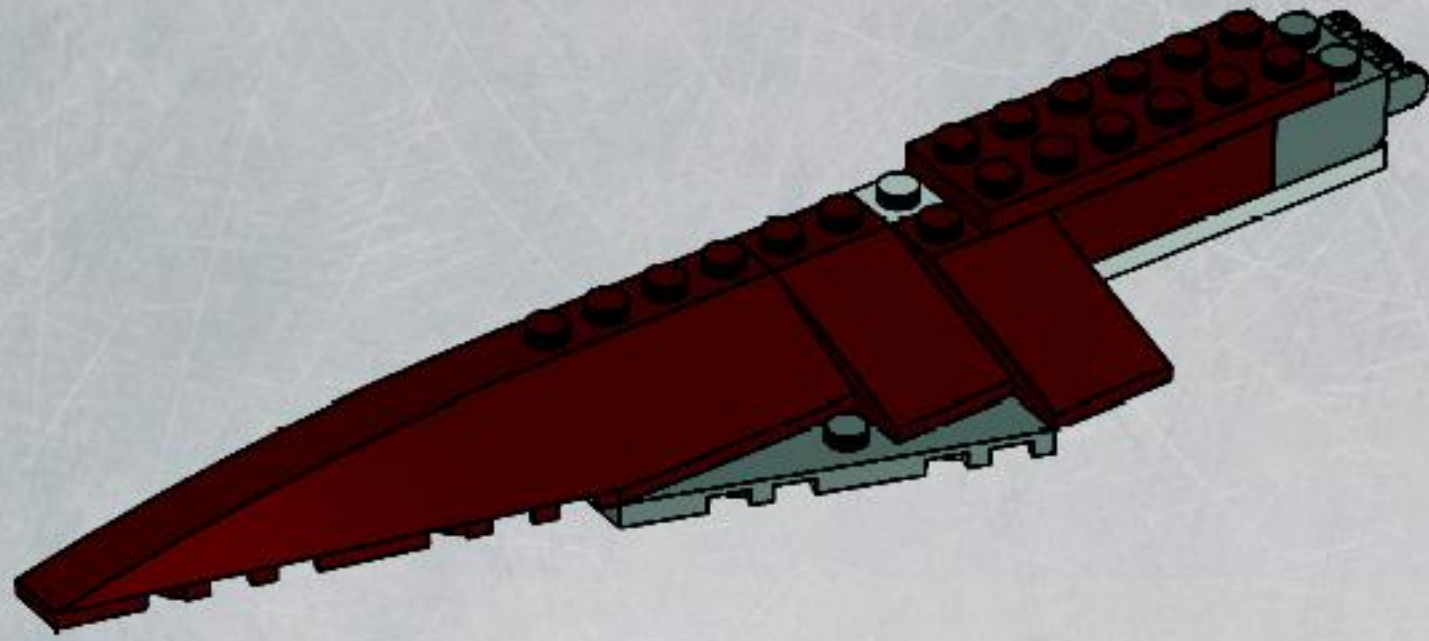

6

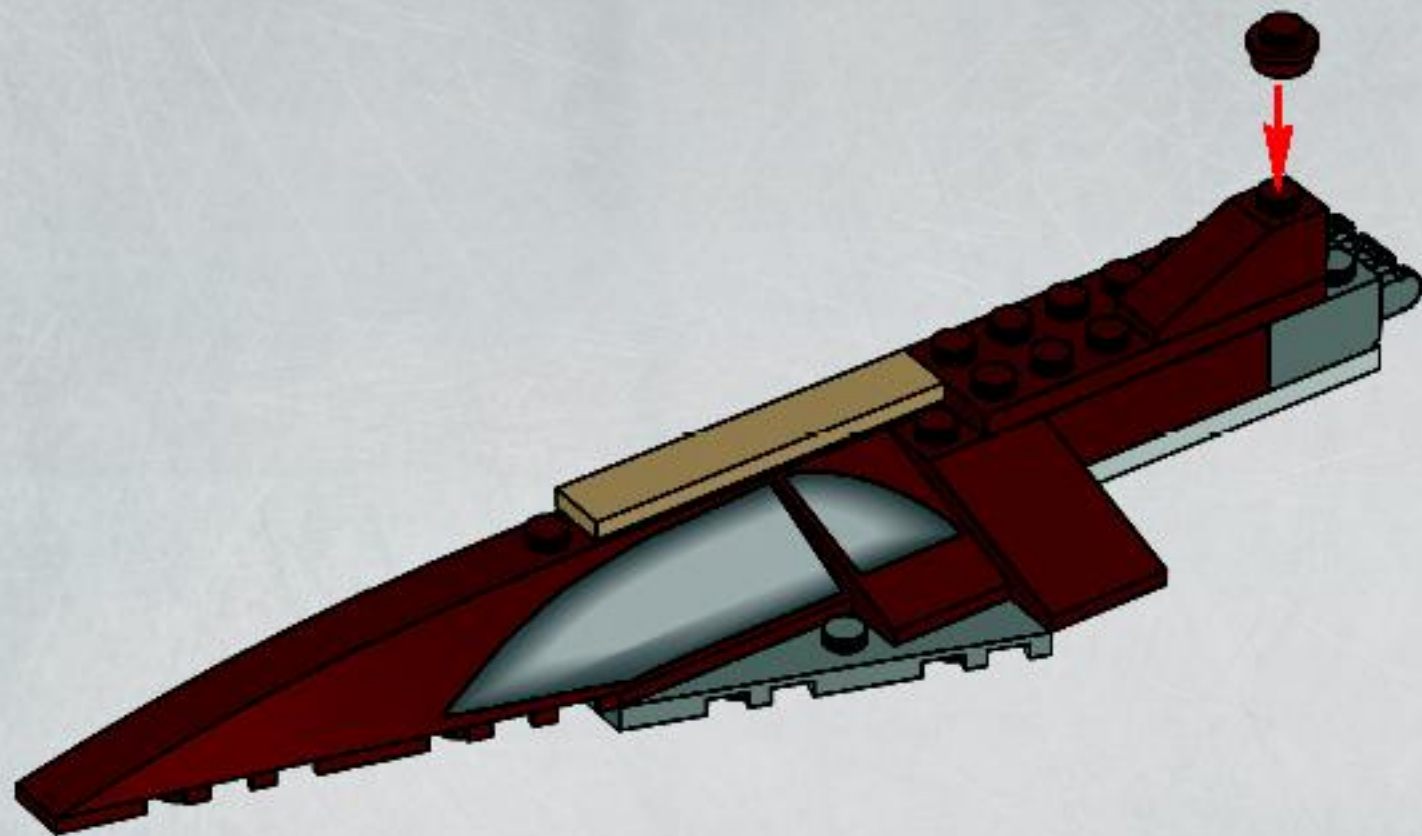

24

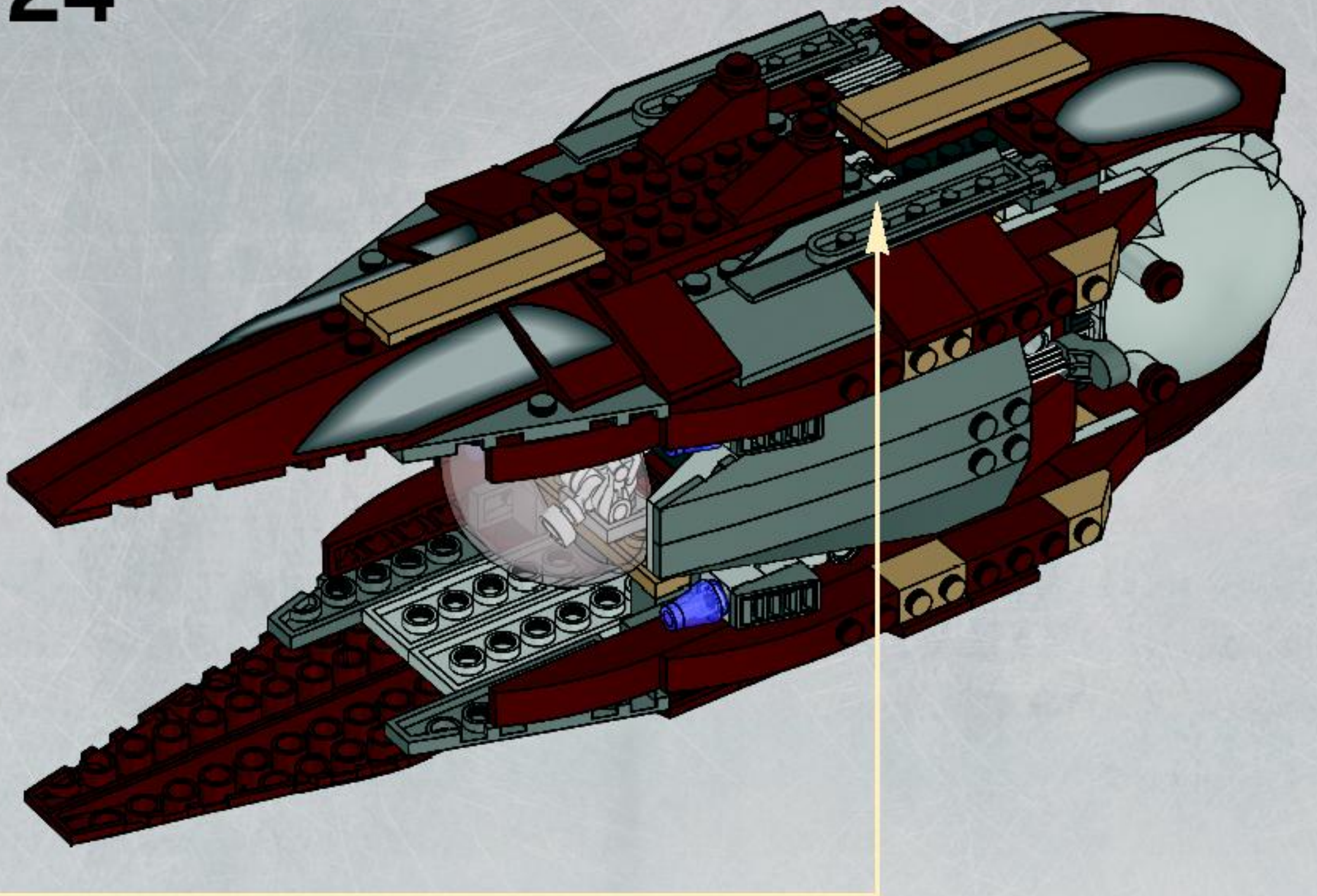

25

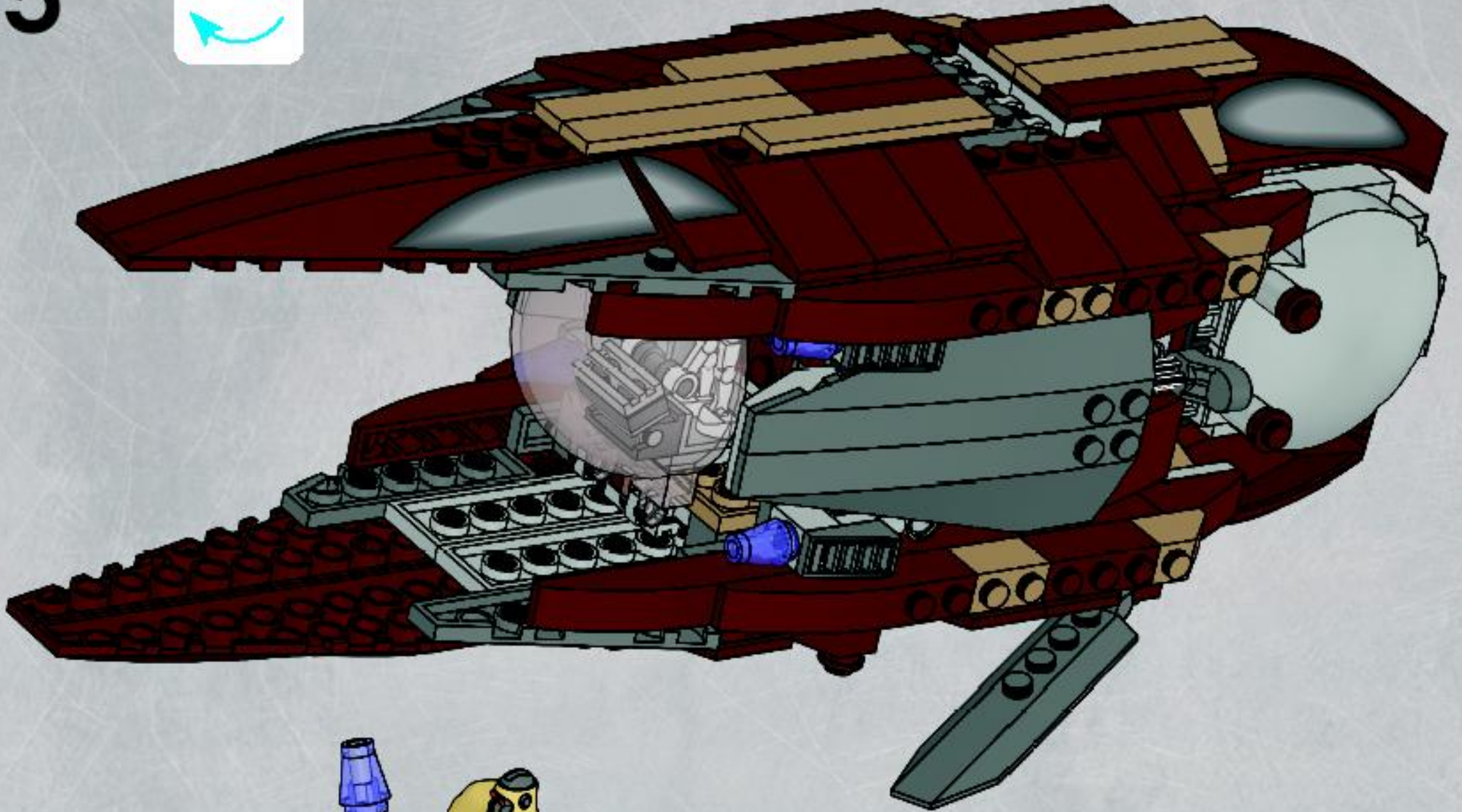



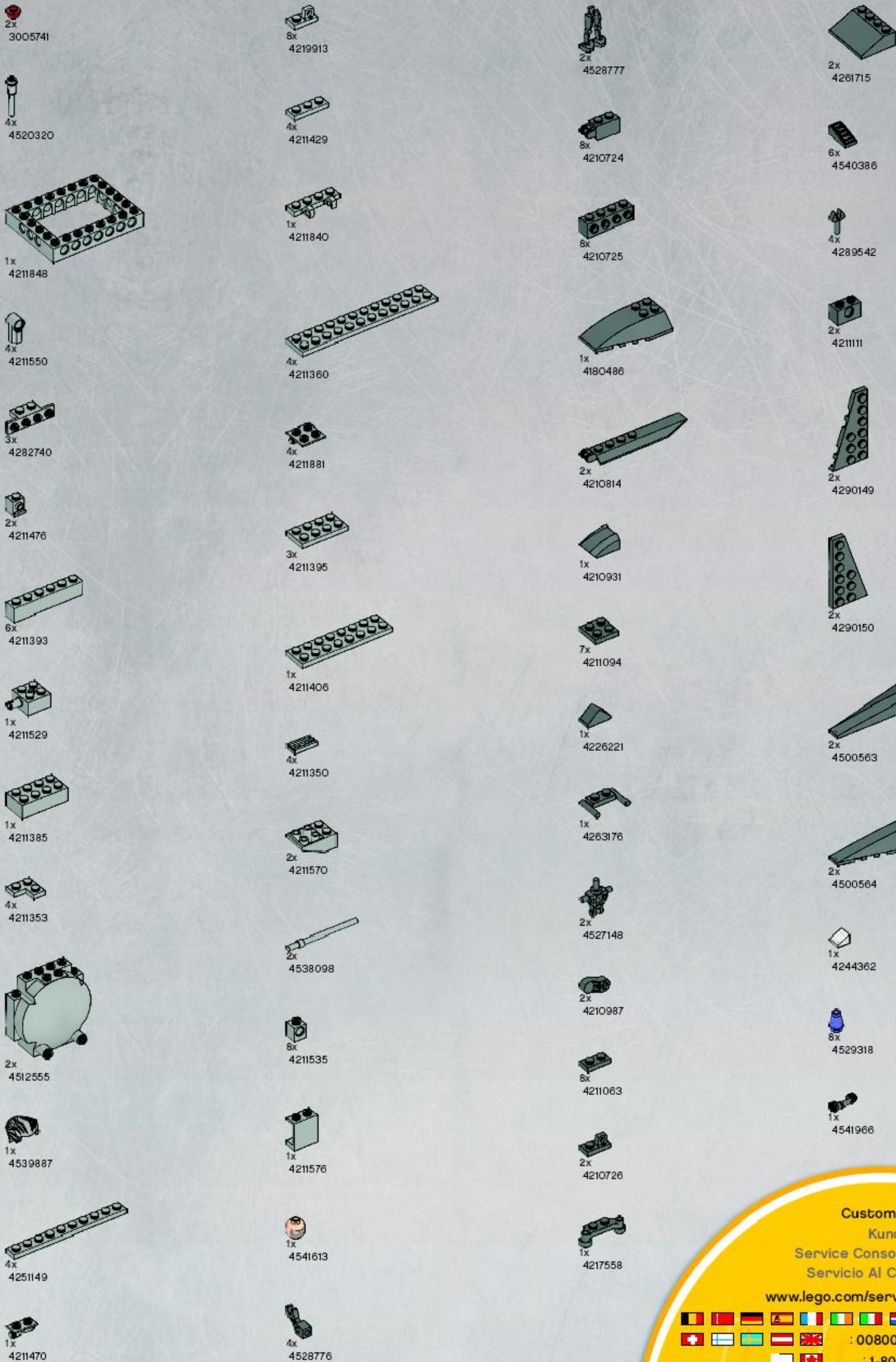

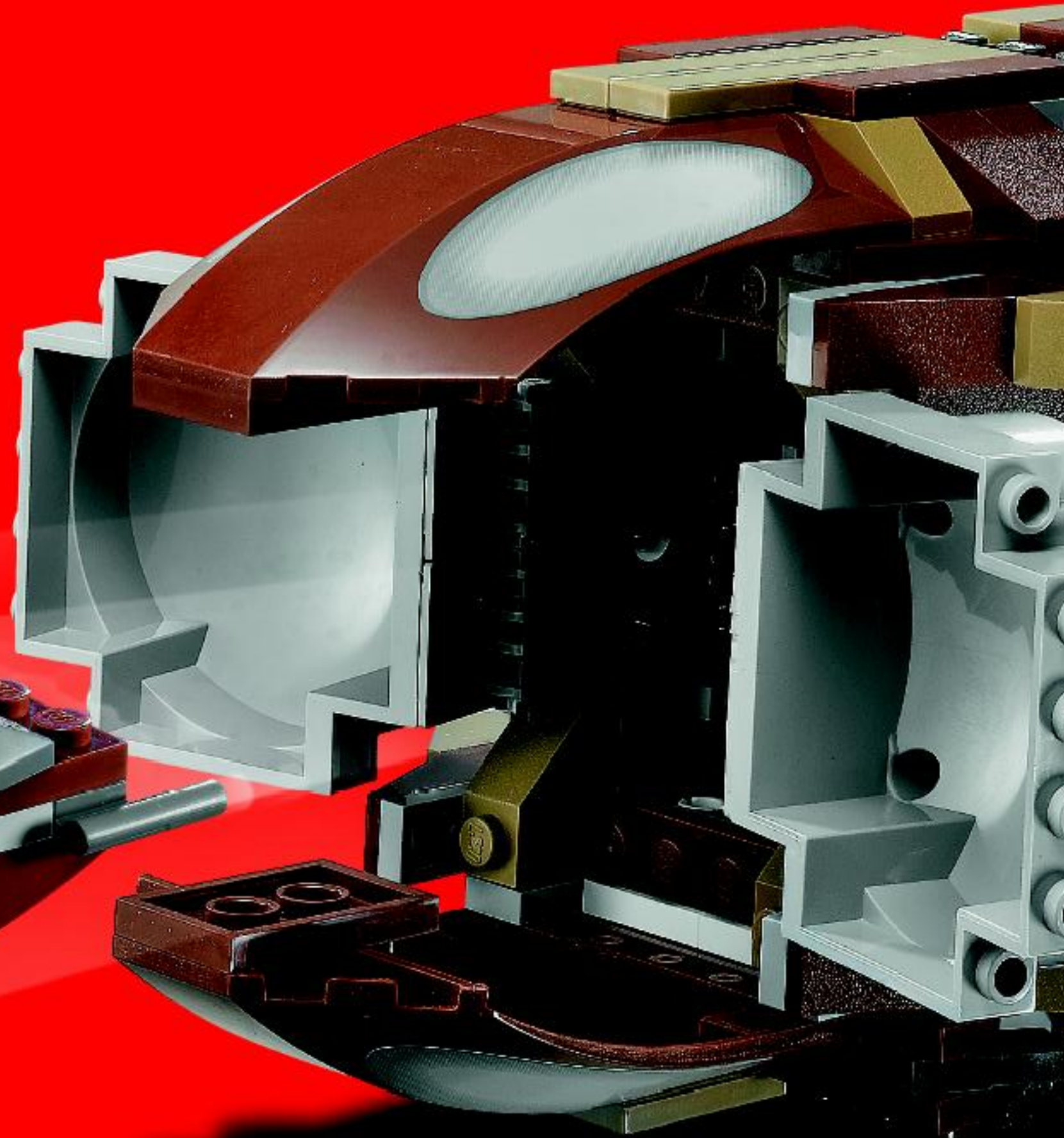
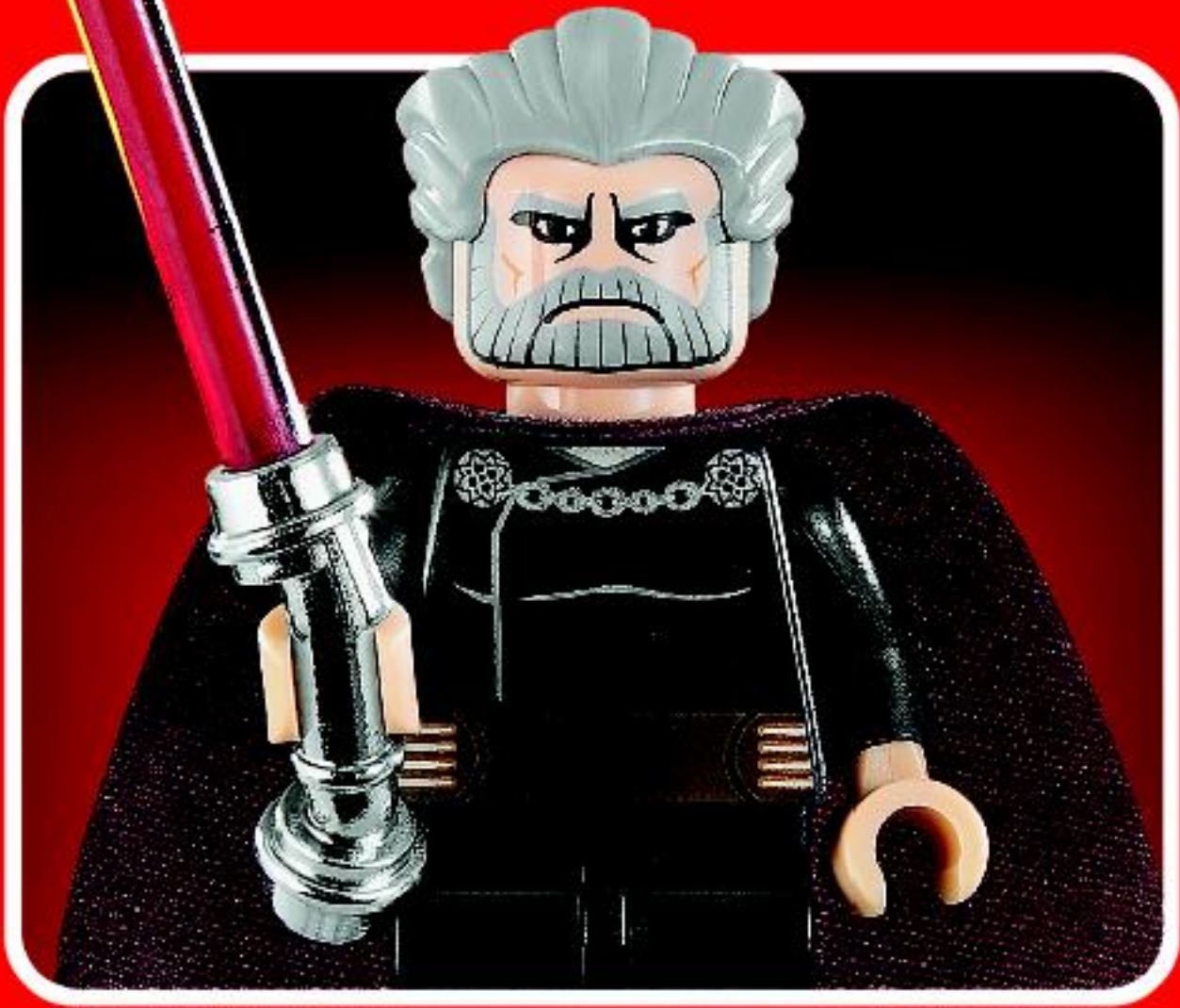

Customer Service
Kundenservice
Service Consommateurs
Servicio Al Consumidor
www.lego.com/service or dial

 : 00800 5346 5555
 : 1-800-422-5346





STAR WARS





8014



8015



8016



8017



8018



8019

FREE! GRATIS! GRATUIT!



club
MAGAZINE™

www.LEGOclub.com



00800 5346 5555*



1-866-534-6258 • 1-877-518-5346

US & Canada only

Canada seulement

* Prephone. Mobile charges may apply. * Nummer sans Frais. Les Frais peuvent s'appliquer avec les téléphones cellulaires. * Gebührenfrei, Kosten für Anrufe aus Mobilfunknetzen können anfallen. * Gratis telefonnummer van Postbode. * Nummer gratisnummer, naar de rijger An Postbode. * Debit gratis, naar de rijger An Postbode.



**VISIT THE WORLD'S
BIGGEST LEGO® SHOP!**

www.LEGOshop.com



WIN LEGO® PRODUCTS

Fill out a survey and you might WIN a cool LEGO product!

NO PURCHASE NECESSARY

Open to all residents where not prohibited

Go to www.acnielsen.aim.dk/LEGO to fill out a survey for a chance to win a LEGO product.

WIN LEGO® PRODUCTEN

Vul een enquêteformulier in en maak kans op een cool LEGO® product!

Kopen niet nodig

Iedereen uit landen waar geen enquêteverbod geldt mag deelnemen.

Ge naar www.acnielsen.aim.dk/LEGO, vul een enquêteformulier in en maak kans op een LEGO product.

GEWINNE LEGO® PRODUKTE

Nimm an der Umfrage teil und GEWINNE ein tolles LEGO® Produkt!

Die Teilnahme am Gewinnspiel führt zu keinerlei Kaufverpflichtungen

Teilnahme in allen nicht ausgeschlossenen Ländern möglich

Wir verlosen unter allen Teilnehmern der Umfrage auf

www.acnielsen.aim.dk/LEGO LEGO Produkte.

GAGNE DES PRODUITS LEGO®

Réponds à un questionnaire et tu pourras GAGNER un produit LEGO® très cool !

Aucune obligation d'achat.

Ouvert à tous les résidents des pays autorisés.

Visite www.acnielsen.aim.dk/LEGO pour répondre à un questionnaire et avoir une chance de gagner un produit LEGO.

レゴ®製品を「当てよう」

アンケートに記入して、かっこいいレゴ®製品を当てよう！

お買い上げの必要はありません。

禁止されていない限り、すべての皆様にご利用いただけます。

www.acnielsen.aim.dk/LEGOにアクセスして、アンケートにご記入ください。当選者にはレゴ®製品を差し上げます。



WIN
WIN
GEWINNE
GAGNE
「当てよう」

